



**THE DATASHEET OF
REF02CZ**



FEATURES

- 5 V output: $\pm 0.3\%$ maximum**
- Temperature voltage output: $1.96 \text{ mV}/^\circ\text{C}$**
- Adjustment range: $\pm 3\%$ minimum**
- Excellent temperature stability: $8.5 \text{ ppm}/^\circ\text{C}$ maximum**
- Low noise: $15 \mu\text{V p-p}$ maximum**
- Low supply current: 1.4 mA maximum**
- Wide input voltage range: 7 V to 40 V**
- High load-driving capability: 10 mA**
- No external components**
- Short-circuit proof**

GENERAL DESCRIPTION

The REF02 precision voltage reference provides a stable 5 V output that can be adjusted over a $\pm 6\%$ range with minimal effect on temperature stability. Single-supply operation over an input voltage range of 7 V to 40 V, low current drain of 1 mA, and excellent temperature stability are achieved with an improved band gap design. Low cost, low noise, and low power make the REF02 an excellent choice whenever a stable voltage reference is required. Applications include DACs and ADCs, portable instrumentation, and digital voltmeters. The versatility of the REF02 is enhanced by its use as a monolithic temperature transducer. For new designs, refer to the ADR02.

PIN CONFIGURATIONS

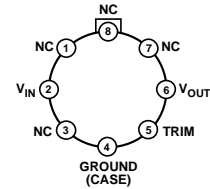

NC = NO CONNECT. DO NOT CONNECT ANYTHING ON THESE PINS. SOME OF THEM ARE RESERVED FOR FACTORY TESTING PURPOSES.

Figure 1. 8-Lead TO-99 (J-Suffix)

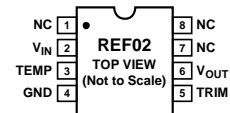

NC = NO CONNECT. DO NOT CONNECT ANYTHING ON THESE PINS. SOME OF THEM ARE RESERVED FOR FACTORY TESTING PURPOSES.

Figure 2. 8-Lead PDIP (P-Suffix), 8-Lead CERDIP (Z-Suffix) and 8-Lead SOIC (S-Suffix)

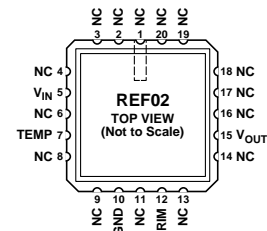

NC = NO CONNECT. DO NOT CONNECT ANYTHING ON THESE PINS. SOME OF THEM ARE RESERVED FOR FACTORY TESTING PURPOSES.

Figure 3. 20-Terminal LCC (RC-Suffix)

REF02 OPTION	R9	R11	R12
883C PRODUCT	18k Ω	2k Ω	6.1k Ω
P, S, J, Z PACKAGES	18k Ω	4.5k Ω	15k Ω

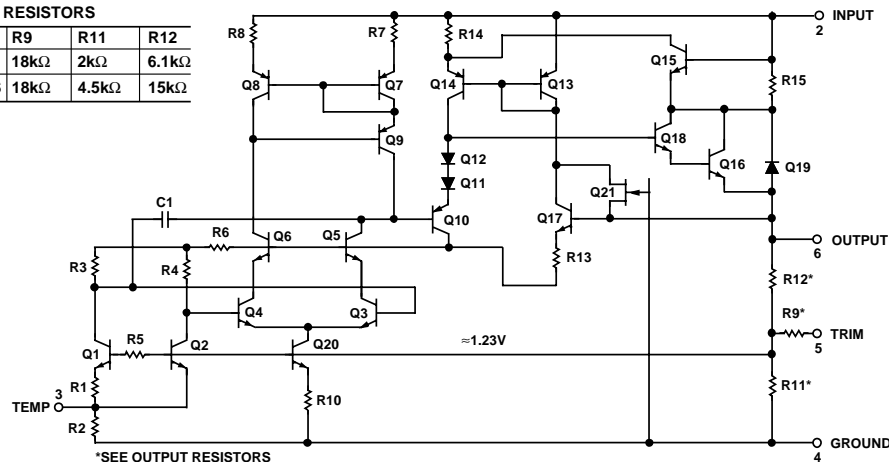

Figure 4. Simplified Schematic

Rev. 1

Information furnished by Analog Devices is believed to be accurate and reliable. However, no responsibility is assumed by Analog Devices for its use, nor for any infringements of patents or other rights of third parties that may result from its use. Specifications subject to change without notice. No license is granted by implication or otherwise under any patent or patent rights of Analog Devices. Trademarks and registered trademarks are the property of their respective owners.

TABLE OF CONTENTS

Features	1	Typical Performance Characteristics	8
General Description	1	Output Adjustment	10
Pin Configurations	1	Temperature Monitoring	11
Revision History	2	Reference Stack with Excellent Line Regulation	11
Specifications.....	3	Precision Current Source	12
Electrical Specifications.....	3	Supply Bypassing	12
Absolute Maximum Ratings.....	7	Outline Dimensions	13
Thermal Resistance	7	Ordering Guide	15
ESD Caution.....	7		
REVISION HISTORY			
12/05—Rev. H to Rev. I			
Changes to Figure 14.....	10	10/03—Rev. C to Rev. D	
Changes to Ordering Guide	15	Updated TPCs.....	Universal
5/05—Rev. G to Rev. H		Changes to Features	1
Updated Figure 4	1	Changes to Electrical Specifications	2
Changes to Specifications	3	Change to Absolute Maximum Ratings	4
Updated Outline Dimensions	13	Changes to Ordering Guide	4
Changes to Ordering Guide	15	Deleted Typical Electrical Characteristics table	4
2/05—Rev. F to Rev. G		Deleted Wafer Test Limits	4
Changes to Specifications	3	Deleted Figure 1.....	4
Change to Outline Dimensions	13	10/02—Rev. B to Rev. C	
7/04—Rev. E to Rev. F		Changes to Features	1
Updated Format.....	Universal	Changes to General Description	1
Changes to Simplified Schematic	1	Changes to Simplified Schematic	1
Changes to Specifications	3	Changes to Specifications.....	2
Changes to Specifications	4	Changes to Absolute Maximum Ratings	5
Changes to Specifications	5	Changes to Package Type	5
Changes to Specifications	6	Changes to Ordering Guide	5
Changes to Figure 18.....	10	Updated to Outline Dimensions	11
Changes to Ordering Guide	15		
3/04—Rev. D to Rev. E			
Changes to Features.....	1		
Changes to Specifications	2		
Changes to Ordering Guide	4		
Replaced TPCs 3 and 4	5		
Added Temperature Monitoring section	7		
Updated Figure 5	7		
Deleted Table I	7		
Updated Figure 6	7		

SPECIFICATIONS

ELECTRICAL SPECIFICATIONS

@ $V_{IN} = 15\text{ V}$, $T_A = 25^\circ\text{C}$, unless otherwise noted.

Table 1.

Parameter	Symbol	Conditions	REF02A/REF02E			REF02/REF02H			Unit
			Min	Typ	Max	Min	Typ	Max	
Output Voltage	V_O	$I_L = 0\text{ mA}$	4.985	5.000	5.015	4.975	5.000	5.025	V
Output Adjustment Range	ΔV_{TRIM}	$R_P = 10\text{ k}\Omega$	± 3	± 6		± 3	± 6		%
Output Voltage Noise ¹	e_n p-p	0.1 Hz to 10 Hz							
P, Z, and S Packages				15			15		$\mu\text{V p-p}$
J Package				20			20		$\mu\text{V p-p}$
883 Parts				10	15		10	15	$\mu\text{V p-p}$
Line Regulation ²		$V_{IN} = 8\text{ V to }40\text{ V}$		0.006	0.010		0.006	0.010	%/V
Load Regulation ²		$I_L = 0\text{ mA to }10\text{ mA}$		0.005	0.010		0.006	0.010	%/mA
Turn-On Settling Time ¹	t_{ON}	To $\pm 0.1\%$ of final value		5			5		μs
Quiescent Supply Current	I_{SY}	No load		1.0	1.4		1.0	1.4	mA
Load Current	I_L		10			10			mA
Sink Current ³	I_S		-0.3	-0.5		-0.3	-0.5		mA
Short-Circuit Current	I_{SC}	$V_O = 0$		30			30		mA
Temperature Voltage Output ⁴									
883C Product	V_T			630			630		mV
P, S, J, and Z Packages	V_T			550			550		mV

¹ Guaranteed by design.

² Line and load regulation specifications include the effect of self-heating.

³ During sink current test, the device meets the output voltage specified.

⁴ Limit current in or out of Pin 3 to 50 nA and capacitance on Pin 3 to 30 pF.

REF02

@ $V_{IN} = 15\text{ V}$, $-55^{\circ}\text{C} \leq T_A \leq +125^{\circ}\text{C}$ for REF02A and REF02; $0^{\circ}\text{C} \leq T_A \leq 70^{\circ}\text{C}$ for REF02E and REF02H; $I_L = 0\text{ mA}$, unless otherwise noted.

Table 2.

Parameter	Symbol	Conditions	REF02A/REF02E			REF02/REF02H			Unit
			Min	Typ	Max	Min	Typ	Max	
Output Voltage Change with Temperature ^{1,2}	ΔV_{OT}	$0^{\circ}\text{C} \leq T_A \leq 70^{\circ}\text{C}$ $-55^{\circ}\text{C} \leq T_A \leq +125^{\circ}\text{C}$		0.02	0.06		0.07	0.17	%
Output Voltage Temperature Coefficient ³	TCV_O			0.06	0.15		0.18	0.45	%
Change in V_O Temperature Coefficient with Output Adjustment		$R_P = 10\text{ k}\Omega$		3	8.5		10	25	ppm/ $^{\circ}\text{C}$
Line Regulation $V_{IN} = 8\text{ V to }40\text{ V}^4$		$0^{\circ}\text{C} \leq T_A \leq 70^{\circ}\text{C}$ $-55^{\circ}\text{C} \leq T_A \leq +125^{\circ}\text{C}$		0.7			0.7		ppm/%
Load Regulation $I_L = 0\text{ mA to }8\text{ mA}^4$		$0^{\circ}\text{C} \leq T_A \leq 70^{\circ}\text{C}$ $-55^{\circ}\text{C} \leq T_A \leq +125^{\circ}\text{C}$		0.007	0.012		0.007	0.012	%/V
Temperature Voltage Output Temperature Coefficient ⁵ 883C Product P, S, J, and Z Packages	TCV_T			0.009	0.015		0.009	0.015	%/V
				0.006	0.010		0.007	0.012	%/mA
				0.007	0.012		0.009	0.015	%/mA
				2.10			2.10		mV/ $^{\circ}\text{C}$
				1.96			1.96		mV/ $^{\circ}\text{C}$

¹ ΔV_{OT} is defined as the absolute difference between the maximum output voltage and the minimum output voltage over the specified temperature range expressed as a percentage of 5 V.

$$\Delta V_{OT} = \left| \frac{V_{MAX} - V_{MIN}}{5\text{ V}} \right| \times 100$$

² ΔV_{OT} specification applies trimmed to 5,000 V or untrimmed.

³ TCV_O is defined as ΔV_{OT} divided by the temperature range.

$$TCV_O = \frac{\Delta V_{OT}}{70^{\circ}\text{C}}$$

⁴ Line and load regulation specifications include the effect of self-heating.

⁵ Limit current in or out of Pin 3 to 50 nA and capacitance on Pin 3 to 30 pF.

@ $V_{IN} = 15\text{ V}$, $T_A = 25^\circ\text{C}$, unless otherwise noted.

Table 3.

Parameter	Symbol	Conditions	REF02C			REF02D			Unit
			Min	Typ	Max	Min	Typ	Max	
Output Voltage	V_O	$I_L = 0\text{ mA}$	4.950	5.000	5.050	4.900	5.000	5.100	V
Output Adjustment Range	ΔV_{TRIM}	$R_p = 10\text{ k}\Omega$	± 2.7	± 6.0		± 2.0	± 6.0		%
Output Voltage Noise ¹ P, Z, and S Packages	e_n p-p	0.1 Hz to 10 Hz		15					$\mu\text{V p-p}$
J Package				20			15		$\mu\text{V p-p}$
883 Parts				12	18		20		$\mu\text{V p-p}$
Line Regulation ²		$V_{IN} = 8\text{ V to }40\text{ V}$		0.009	0.015		0.010	0.04	%/V
Load Regulation ²		$I_L = 0\text{ mA to }8\text{ mA}$		0.006	0.015				%/mA
		$I_L = 0\text{ mA to }4\text{ mA}$					0.015	0.04	%/mA
Turn-On Settling Time ¹	t_{ON}	To $\pm 0.1\%$ of final value		5			5		μs
Quiescent Supply Current	I_{SY}	No load		1.0	1.6		1.0	2.0	mA
Load Current	I_L		8			8			mA
Sink Current ³	I_S		-0.3	-0.5		-0.3	-0.5		mA
Short-Circuit Current	I_{SC}	$V_O = 0$		30			30		mA
Temperature Voltage Output ⁴ 883C Product	V_T			630			630		mV
P, S, J, and Z Packages	V_T			550			550		mV

¹ Guaranteed by design.

² Line and load regulation specifications include the effect of self-heating.

³ During sink current test, the device meets the output voltage specified.

⁴ Limit current in or out of Pin 3 to 50 nA and capacitance on Pin 3 to 30 pF.

REF02

@ $V_{IN} = 15\text{ V}$, $I_L = 0\text{ mA}$, $0^\circ\text{C} \leq T_A \leq 70^\circ\text{C}$ for REF02CJ, REF02CZ, and REF02DP; and $-40^\circ\text{C} \leq T_A \leq +85^\circ\text{C}$ for REF02CP and REF02CS, unless otherwise noted.

Table 4.

Parameter	Symbol	Conditions	REF02C			REF02D			Unit
			Min	Typ	Max	Min	Typ	Max	
Output Voltage Change with Temperature ^{1,2}	ΔV_{OT}			0.14	0.45		0.49	1.7	%
Output Voltage Temperature Coefficient ³	TCV_o	$R_P = 10\text{ k}\Omega$		20	65		70	250	ppm/ $^\circ\text{C}$
Change in V_o Temperature Coefficient with Output Adjustment				0.7		0.7			ppm/%
Line Regulation ⁴		$V_{IN} = 8\text{ V to } 40\text{ V}$ $I_L = 0\text{ mA to } 5\text{ mA}$		0.011	0.018		0.012	0.05	%/V
Load Regulation ⁴				0.008	0.018		0.016	0.05	%/mA
Temperature Voltage Output Temperature Coefficient ⁵			TCV_T						
883C Product				2.10			2.10		mV/ $^\circ\text{C}$
P, S, J, and Z Packages				1.96			1.96		mV/ $^\circ\text{C}$

¹ ΔV_{OT} is defined as the absolute difference between the maximum output voltage and the minimum output voltage over the specified temperature range expressed as a percentage of 5 V.

$$\Delta V_{OT} = \left| \frac{V_{MAX} - V_{MIN}}{5\text{ V}} \right| \times 100$$

² ΔV_{OT} specification applies trimmed to 5,000 V or untrimmed.

³ TCV_o is defined as ΔV_{OT} divided by the temperature range.

$$TCV_o = \frac{\Delta V_{OT}}{70^\circ\text{C}}$$

⁴ Line and load regulation specifications include the effect of self-heating.

⁵ Limit current in or out of Pin 3 to 50 nA and capacitance on Pin 3 to 30 pF.

ABSOLUTE MAXIMUM RATINGS

Table 5.

Parameter	Rating ¹
Input Voltage	40 V
Output Short-Circuit Duration to Ground or V_{IN}	Indefinite
Storage Temperature Range	
J, RC, and Z Packages	–65°C to +150°C
P Package	–65°C to +125°C
Operating Temperature Range	
REF02A, REF02J, REF02RC	–55°C to +125°C
REF02CJ, REF02CZ	0°C to 70°C
REF02CP, REF02CS, REF02E, and REF02H	–40°C to +85°C
Lead Temperature Range (Soldering 10 sec)	300°C

¹ Absolute maximum ratings apply to both DICE packaged parts, unless otherwise noted.

Stresses above those listed under Absolute Maximum Ratings may cause permanent damage to the device. This is a stress rating only; functional operation of the device at these or any other conditions above those indicated in the operational section of this specification is not implied. Exposure to absolute maximum rating conditions for extended periods may affect device reliability.

THERMAL RESISTANCE

Table 6.

Package Type	θ_{JA} ¹	θ_{JC}	Unit
TO-99 (J)	170	24	°C/W
8-Lead CERDIP (Z)	162	26	°C/W
8-Lead PDIP (P)	110	50	°C/W
20-Terminal Ceramic LCC (RC)	120	40	°C/W
8-Lead SOIC (S)	160	44	°C/W

¹ θ_{JA} is specified for worst-case mounting conditions; device in socket for TO, CERDIP, PDIP, and LCC packages; and device soldered to printed circuit board for SOIC package.

ESD CAUTION

ESD (electrostatic discharge) sensitive device. Electrostatic charges as high as 4000 V readily accumulate on the human body and test equipment and can discharge without detection. Although this product features proprietary ESD protection circuitry, permanent damage may occur on devices subjected to high energy electrostatic discharges. Therefore, proper ESD precautions are recommended to avoid performance degradation or loss of functionality.



TYPICAL PERFORMANCE CHARACTERISTICS

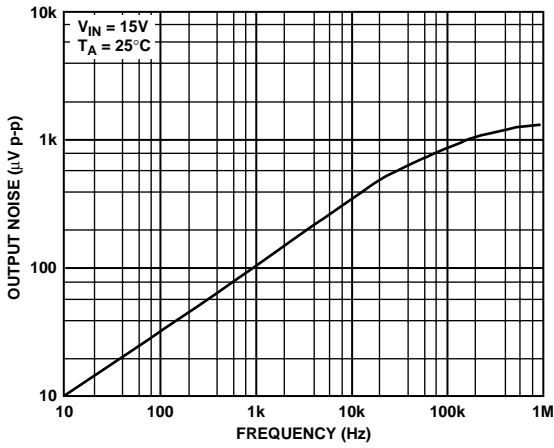

Figure 5. Output Wideband Noise vs. Bandwidth (0.1 Hz to Frequency Indicated)

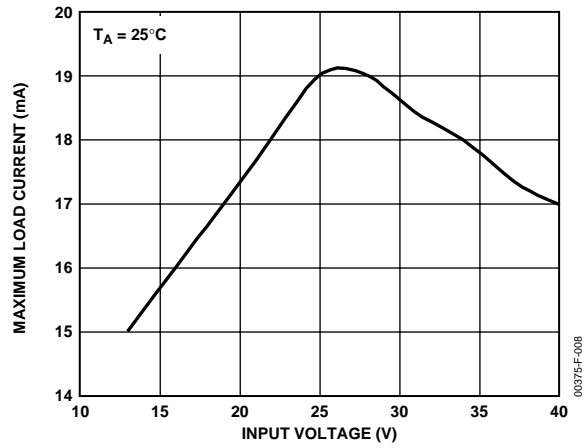

Figure 8. Maximum Load Current vs. Input Voltage

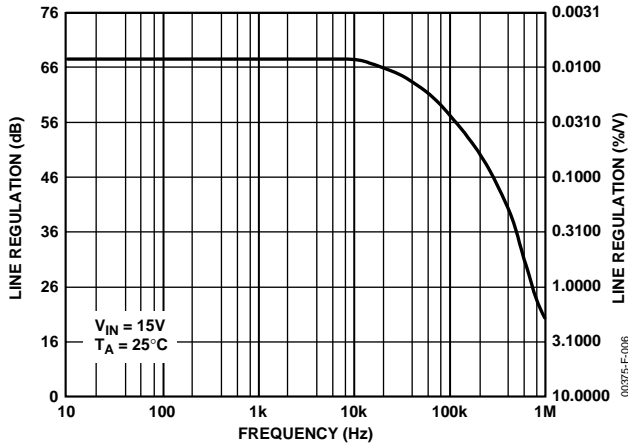

Figure 6. Line Regulation vs. Frequency

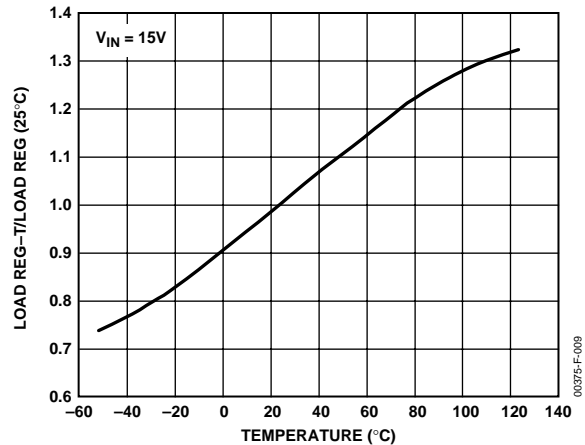

Figure 9. Normalized Load Regulation ($\Delta I_L = 10\text{ mA}$) vs. Temperature

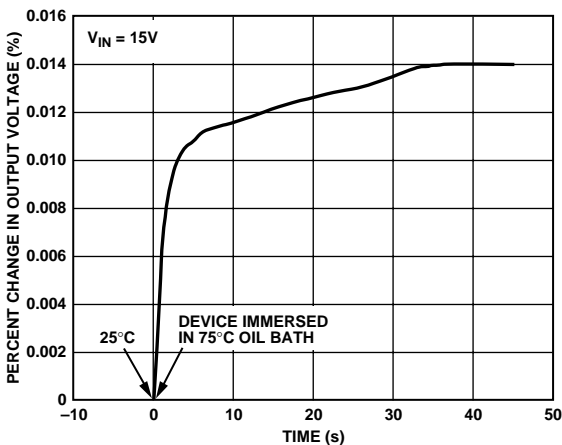

Figure 7. Output Change Due to Thermal Shock

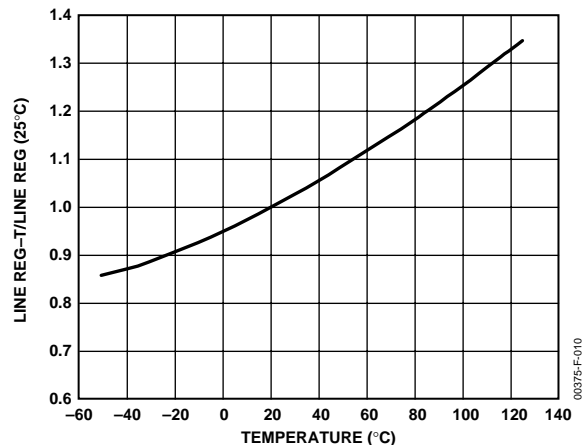

Figure 10. Normalized Line Regulation vs. Temperature

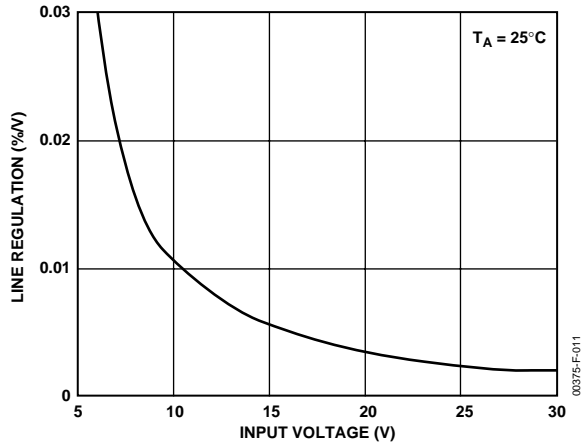

Figure 11. Line Regulation vs. Input Voltage

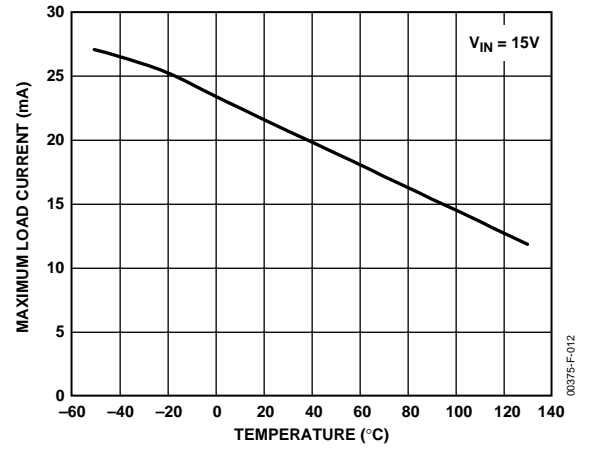

Figure 13. Maximum Load Current vs. Temperature

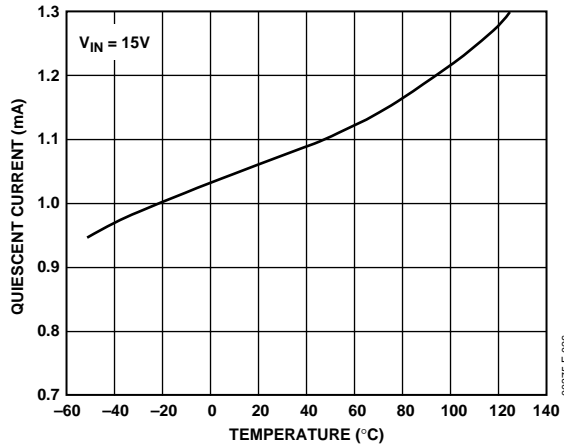

Figure 12. Quiescent Current vs. Temperature

TEMPERATURE MONITORING

The REF02 provides a TEMP output (Pin 3) that varies linearly with temperature. This output can be used to monitor the temperature change in the system. The voltage at V_{TEMP} is approximately 550 mV at 25°C, and the temperature coefficient is approximately 1.96 mV/°C (see Figure 18).

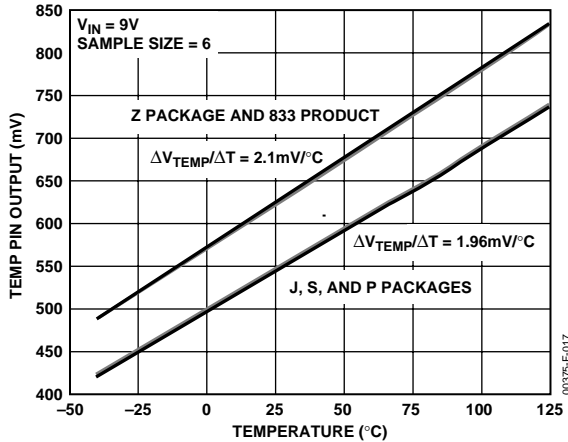

Figure 18. Voltage at TEMP Pin vs. Temperature

A voltage change of 39.2 mV at the TEMP pin corresponds to a 20°C change in temperature.

The TEMP function is provided as a convenience rather than a precise feature. Since the voltage at the TEMP node is acquired from the band gap core, current pulling from this pin has a significant effect on V_{OUT} . Care must be taken to buffer the TEMP output with a suitable low bias current op amp, such as the AD8601, AD820, or OP1177. Using any of these three op amps results in less than a 100 μ V change in ΔV_{OUT} (see Figure 19). Without buffering, even tens of microamps drawn from the TEMP pin can cause V_{OUT} to fall out of specification.

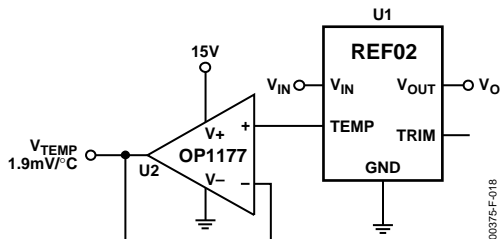

Figure 19. Temperature Monitoring

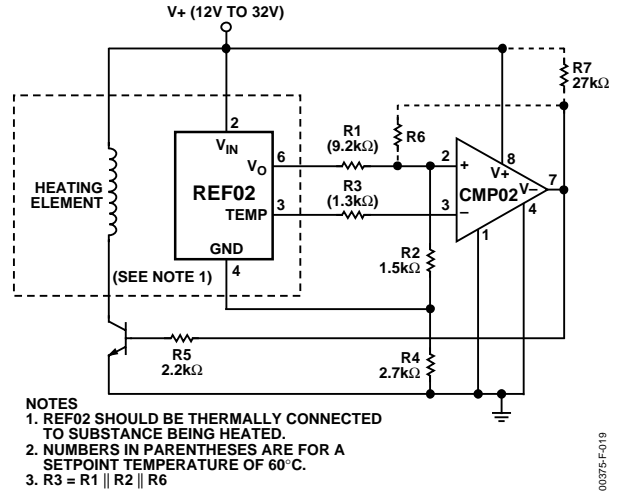

Figure 20. Temperature Controller

REFERENCE STACK WITH EXCELLENT LINE REGULATION

Two REF01s and one REF02 can be stacked to yield 5.00 V, 15.00 V, and 25.00 V outputs. An additional advantage is near-perfect line regulation of the 5.0 V and 15.0 V output. A 27 V to 55 V input change produces an output change that is less than the noise voltage of the devices. A load bypass resistor (R_B) provides a path for the supply current (I_{SV}) of the 15.00 V regulator.

In general, any number of REF01s and REF02s can be stacked this way. For example, 10 devices yield 10 outputs in 5 V or 10 V steps. The line voltage can change from 100 V to 130 V. Care must be taken, however, to ensure that the total load currents do not exceed the maximum usable current (typically 21 mA).

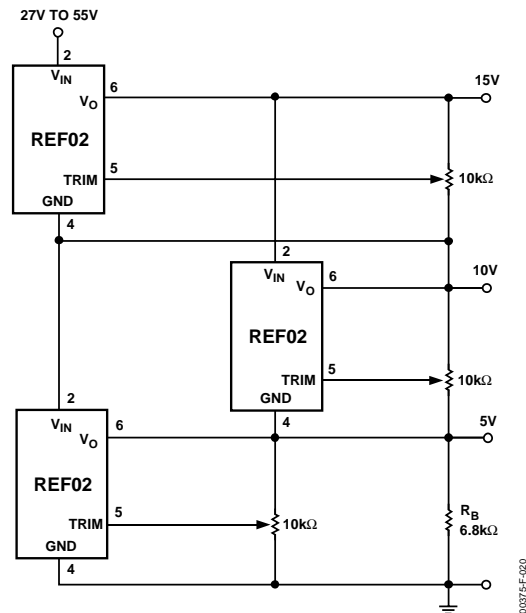

Figure 21. Reference Stack

REF02

PRECISION CURRENT SOURCE

A current source with 35 V output compliance and excellent output impedance can be obtained using this circuit. REF02 keeps the line voltage and power dissipation constant in the device; the only important error consideration at room temperature is the negative supply rejection of the op amp. The typical $3 \mu\text{V}/\text{V}$ PSRR of the OP02E creates a 20 ppm change ($3 \mu\text{V}/\text{V} \times 35 \text{ V}/5 \text{ V}$) in output current over a 25 V range. For example, a 5 mA current source can be built ($R = 1 \text{ k}\Omega$) with $350 \text{ M}\Omega$ output impedance.

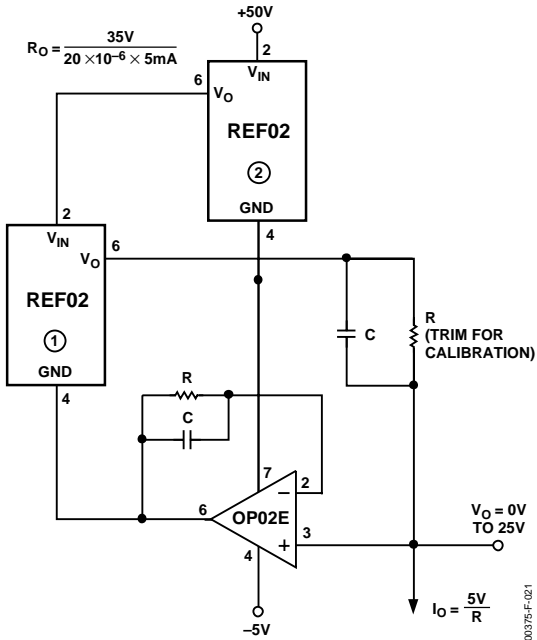

Figure 22. Precision Current Source

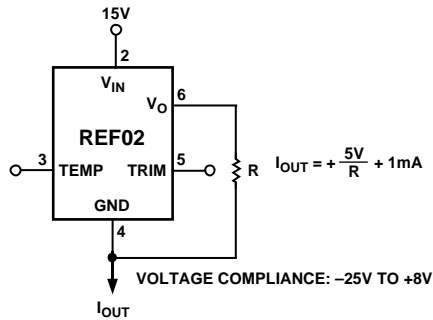

Figure 23. Current Source

SUPPLY BYPASSING

For best results, it is recommended that the power supply pin be bypassed with a $0.1 \mu\text{F}$ disc ceramic capacitor.

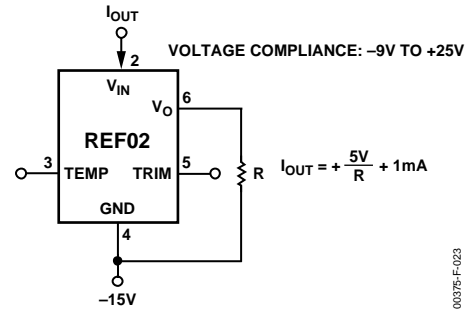

Figure 24. Current Sink

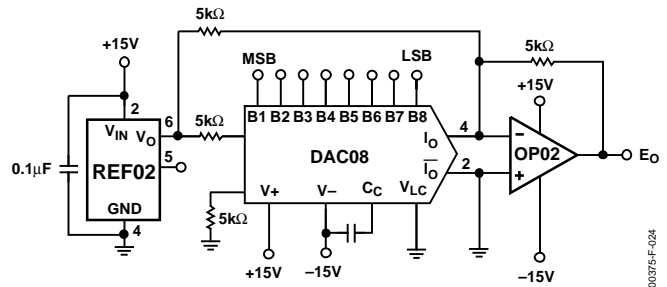

Figure 25. DAC Reference

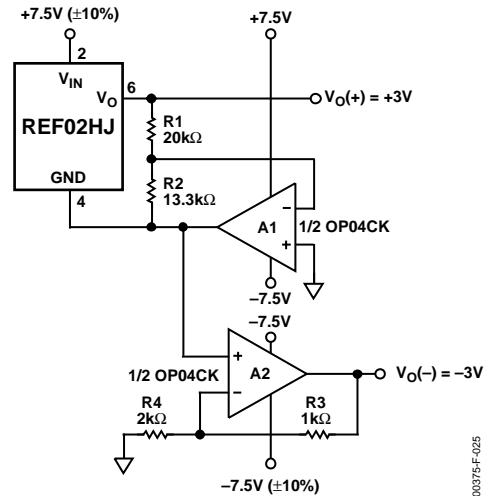
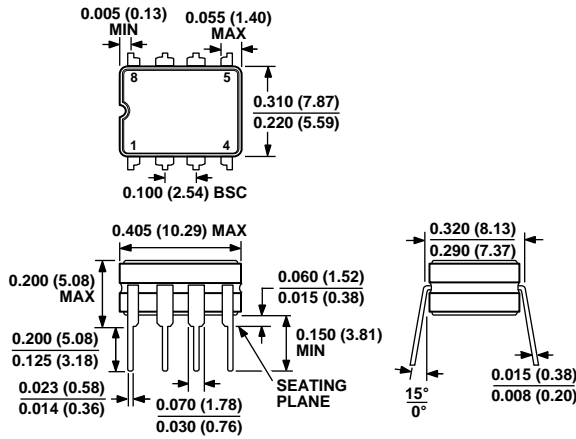

Figure 26. ±3 V Reference

OUTLINE DIMENSIONS



CONTROLLING DIMENSIONS ARE IN INCHES; MILLIMETER DIMENSIONS (IN PARENTHESES) ARE ROUNDED-OFF INCH EQUIVALENTS FOR REFERENCE ONLY AND ARE NOT APPROPRIATE FOR USE IN DESIGN.

Figure 27. 8-Lead Ceramic Dual In-Line Package [CERDIP]
Z-Suffix
(Q-8)
Dimensions shown in inches and (millimeters)

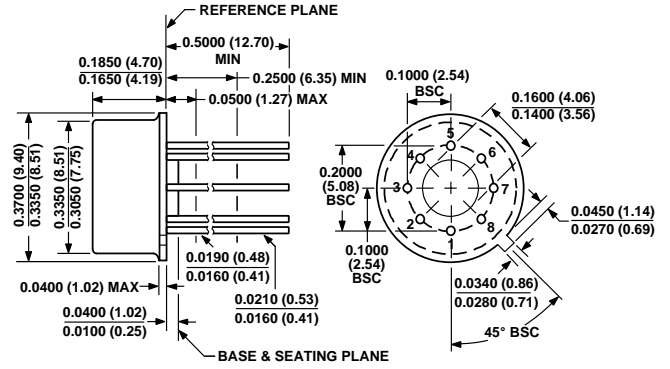

COMPLIANT TO JEDEC STANDARDS MO-002-AK
CONTROLLING DIMENSIONS ARE IN INCHES; MILLIMETER DIMENSIONS (IN PARENTHESES) ARE ROUNDED-OFF INCH EQUIVALENTS FOR REFERENCE ONLY AND ARE NOT APPROPRIATE FOR USE IN DESIGN.

Figure 29. 8-Lead Metal Header Package [TO-99]
J-Suffix
(H-08)
Dimensions shown in inches and (millimeters)

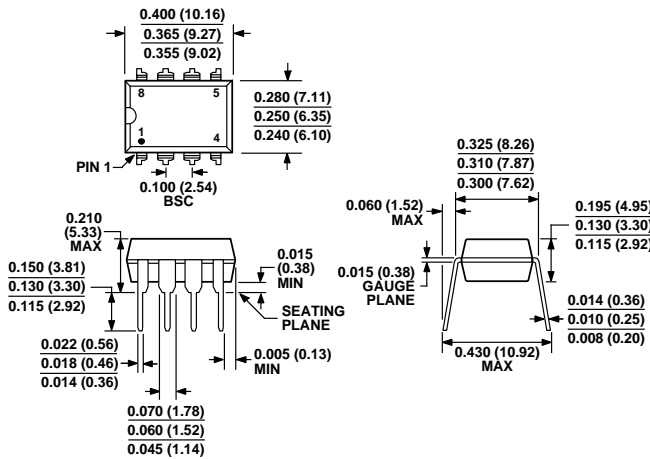

COMPLIANT TO JEDEC STANDARDS MS-001-BA
CONTROLLING DIMENSIONS ARE IN INCHES; MILLIMETER DIMENSIONS (IN PARENTHESES) ARE ROUNDED-OFF INCH EQUIVALENTS FOR REFERENCE ONLY AND ARE NOT APPROPRIATE FOR USE IN DESIGN. CORNER LEADS MAY BE CONFIGURED AS WHOLE OR HALF LEADS.

Figure 28. 8-Lead Plastic Dual In-Line Package [PDIP]
Narrow Body
P-Suffix
(N-8)
Dimensions shown in inches and (millimeters)

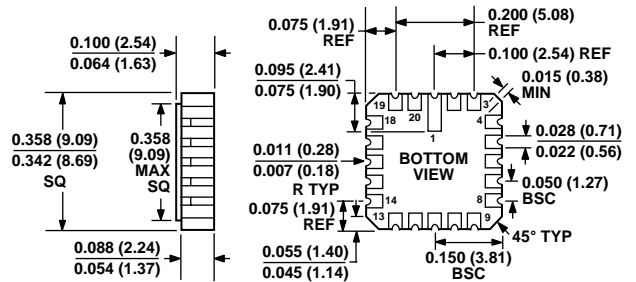

CONTROLLING DIMENSIONS ARE IN INCHES; MILLIMETER DIMENSIONS (IN PARENTHESES) ARE ROUNDED-OFF INCH EQUIVALENTS FOR REFERENCE ONLY AND ARE NOT APPROPRIATE FOR USE IN DESIGN.

Figure 30. 20-Terminal Ceramic Leadless Chip Carrier [LCC]
RC-Suffix
(E-20A)
Dimensions shown in inches and (millimeters)

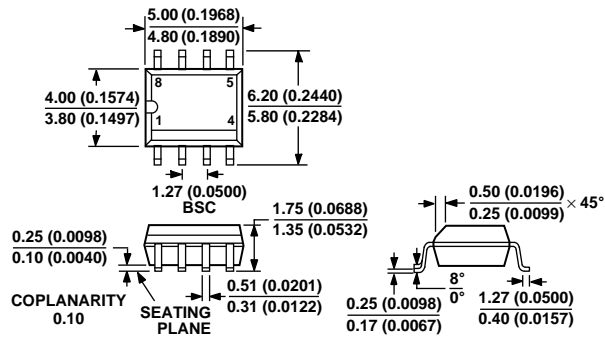

COMPLIANT TO JEDEC STANDARDS MS-012-AA
 CONTROLLING DIMENSIONS ARE IN MILLIMETERS; INCH DIMENSIONS
 (IN PARENTHESES) ARE ROUNDED-OFF MILLIMETER EQUIVALENTS FOR
 REFERENCE ONLY AND ARE NOT APPROPRIATE FOR USE IN DESIGN.

Figure 31. 8-Lead Standard Small Outline Package [SOIC]
 Narrow Body
 S-Suffix
 (R-8)
 Dimensions shown in millimeters and (inches)

ORDERING GUIDE

Model	T _A = 25°C ΔV _{os} Max (mV)	Temperature Range	Package Description	Package Option
REF02AJ/883C ¹	±15	–55°C to +125°C	8-Lead TO-99	J-Suffix (H-08)
REF02AZ	±15	–55°C to +125°C	8-Lead CERDIP	Z-Suffix (Q-8)
REF02AZ/883C ¹	±15	–55°C to +125°C	8-Lead CERDIP	Z-Suffix (Q-8)
REF02CJ	±50	0°C to 70°C	8-Lead TO-99	J-Suffix (H-08)
REF02CP	±50	–40°C to +85°C	8-Lead PDIP	P-Suffix (N-8)
REF02CPZ ²	±50	–40°C to +85°C	8-Lead PDIP	P-Suffix (N-8)
REF02CS	±50	–40°C to +85°C	8-Lead SOIC	S-Suffix (R-8)
REF02CS-REEL	±50	–40°C to +85°C	8-Lead SOIC	S-Suffix (R-8)
REF02CS-REEL7	±50	–40°C to +85°C	8-Lead SOIC	S-Suffix (R-8)
REF02CSZ ²	±50	–40°C to +85°C	8-Lead SOIC	S-Suffix (R-8)
REF02CSZ-REEL ²	±50	–40°C to +85°C	8-Lead SOIC	S-Suffix (R-8)
REF02CSZ-REEL7 ²	±50	–40°C to +85°C	8-Lead SOIC	S-Suffix (R-8)
REF02CZ	±50	0°C to 70°C	8-Lead CERDIP	Z-Suffix (Q-8)
REF02DP	±100	0°C to 70°C	8-Lead PDIP	P-Suffix (N-8)
REF02DPZ ²	±100	0°C to 70°C	8-Lead PDIP	P-Suffix (N-8)
REF02EJ	±15	–40°C to +85°C	8-Lead TO-99	J-Suffix (H-08)
REF02EZ	±15	–40°C to +85°C	8-Lead CERDIP	Z-Suffix (Q-8)
REF02J	±25	–55°C to +125°C	8-Lead TO-99	J-Suffix (H-08)
REF02HJ	±25	–40°C to +85°C	8-Lead TO-99	J-Suffix (H-08)
REF02HZ	±25	–40°C to +85°C	8-Lead CERDIP	Z-Suffix (Q-8)
REF02HP	±25	–40°C to +85°C	8-Lead PDIP	P-Suffix (N-8)
REF02HPZ ²	±25	–40°C to +85°C	8-Lead PDIP	P-Suffix (N-8)
REF02HS	±25	–40°C to +85°C	8-Lead SOIC	S-Suffix (R-8)
REF02HSZ ²	±25	–40°C to +85°C	8-Lead SOIC	S-Suffix (R-8)
REF02RC/883 ¹	±25	–55°C to +125°C	20-Lead LCC	RC-Suffix (E-20A)
REF02Z	±25	–55°C to +125°C	8-Lead CERDIP	Z-Suffix (Q-8)

¹ Consult sales for 883 data sheet.² Z = Pb-free part.

REF02

NOTES

Looking for pricing, stock, or lifecycle information?

Click below to explore more details on WIN SOURCE:

 [View REF02CZ on WIN SOURCE](#)

 [Analog Devices Inc. Information](#)

Optimize Your Supply Chain with WIN SOURCE Solutions

-  Global Sourcing Solution
-  Obsolete Management
-  Cost Control Management
-  Shortage Management
-  Alternative Solution
-  Excess Inventory Management