



**THE DATASHEET OF
SN74LVC161284DLR**



- **1.4-k Ω Pullup Resistors Integrated on All Open-Drain Outputs Eliminate the Need for Discrete Resistors**
- **ESD Protection Exceeds 2000 V Per MIL-STD-883, Method 3015; Exceeds 200 V Using Machine Model (C = 200 pF, R = 0)**
- **Designed for the IEEE Std 1284-I (Level 1 Type) and IEEE Std 1284-II (Level 2 Type) Electrical Specifications**
- **Flow-Through Architecture Optimizes PCB Layout**
- **Package Options Include Plastic 300-mil Shrink Small-Outline (DL) and Thin-Shrink Small-Outline (DGG) Packages**

description/ordering information

The SN74LVC161284 is designed for 3-V to 3.6-V V_{CC} operation. This device provides asynchronous two-way communication between data buses. The control-function implementation minimizes external timing requirements.

This device has eight bidirectional bits; data can flow in the A-to-B direction when DIR is high and in the B-to-A direction when DIR is low. This device also has five drivers, which drive the cable side, and four receivers. The SN74LVC161284 has one receiver dedicated to the HOST LOGIC line and a driver to drive the PERI LOGIC line.

The output drive mode is determined by the high-drive (HD) control pin. When HD is high, the outputs are in a totem-pole configuration, and in an open-drain configuration when HD is low. This meets the drive requirements as specified in the IEEE Std 1284-I (level 1 type) and IEEE Std 1284-II (level 2 type) parallel peripheral-interface specifications. Except for HOST LOGIC IN and PERI LOGIC OUT, all cable-side pins have a 1.4-k Ω integrated pullup resistor. The pullup resistor is switched off if the associated output driver is in the low state or if the output voltage is above V_{CC} CABLE. If V_{CC} CABLE is off, PERI LOGIC OUT is set to low.

The device has two supply voltages. V_{CC} is designed for 3-V to 3.6-V operation. V_{CC} CABLE supplies the inputs and output buffers of the cable side only and is designed for 3-V to 3.6-V and for 4.7-V to 5.5-V operation. Even when V_{CC} CABLE is 3 V to 3.6 V, the cable-side I/O pins are 5-V tolerant.

The SN74LVC161284 is characterized for operation from 0°C to 70°C.

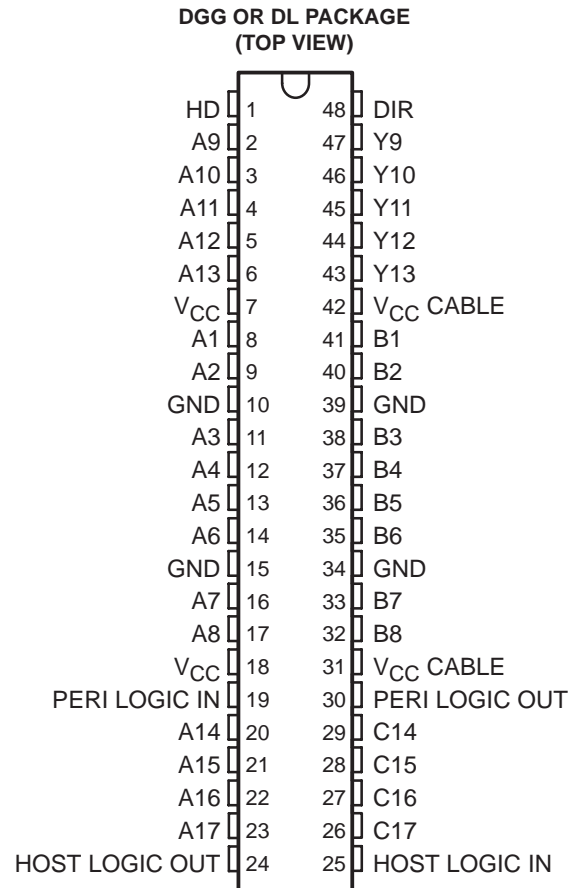

Please be aware that an important notice concerning availability, standard warranty, and use in critical applications of Texas Instruments semiconductor products and disclaimers thereto appears at the end of this data sheet.

PRODUCTION DATA information is current as of publication date. Products conform to specifications per the terms of Texas Instruments standard warranty. Production processing does not necessarily include testing of all parameters.

**TEXAS
INSTRUMENTS**

POST OFFICE BOX 655303 • DALLAS, TEXAS 75265

Copyright © 2005 Texas Instruments Incorporated

SN74LVC161284

19-BIT BUS INTERFACE

SCAS583J – NOVEMBER 1996 – REVISED FEBRUARY 2005

description/ordering information (continued)

ORDERING INFORMATION

TA	PACKAGE†		ORDERABLE PART NUMBER	TOP-SIDE MARKING
0°C to 70°C	TSSOP – DGG	Tape and reel	SN74LVC161284DGGR	PACKAGE PREVIEW
	SSOP – DL	Tape	SN74LVC161284DL	LVC161284
		Tape and reel	SN74LVC161284DLR	
	TSSOP – DGG	Tape and reel	74LVC161284DGGRG4	PACKAGE PREVIEW
	SSOP – DL	Tape	74LVC161284DLRE4	LVC161284
		Tape and reel	74LVC161284DLRG4	

† Package drawings, standard packing quantities, thermal data, symbolization, and PCB design guidelines are available at www.ti.com/sc/package.

FUNCTION TABLE

INPUTS		OUTPUT	MODE
DIR	HD		
L	L	Open drain	A9–A13 to Y9–Y13 and PERI LOGIC IN to PERI LOGIC OUT
		Totem pole	B1–B8 to A1–A8 and C14–C17 to A14–A17
L	H	Totem pole	B1–B8 to A1–A8, A9–A13 to Y9–Y13, PERI LOGIC IN to PERI LOGIC OUT, and C14–C17 to A14–A17
H	L	Open drain	A1–A8 to B1–B8, A9–A13 to Y9–Y13, and PERI LOGIC IN to PERI LOGIC OUT
		Totem pole	C14–C17 to A14–A17
H	H	Totem pole	A1–A8 to B1–B8, A9–A13 to Y9–Y13, C14–C17 to A14–A17, and PERI LOGIC IN to PERI LOGIC OUT

logic diagram

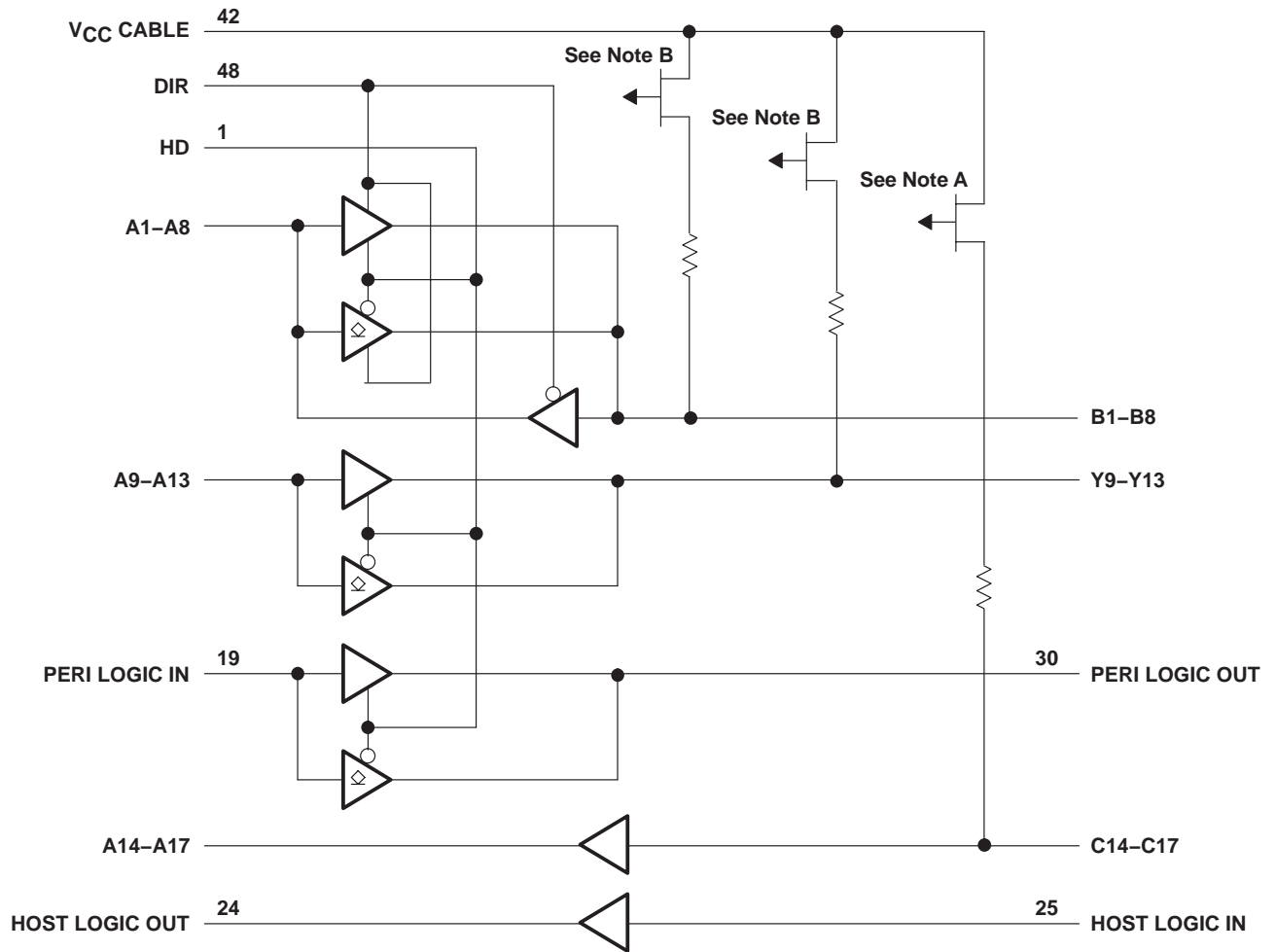

- NOTES: A. The PMOS transistor prevents backdriving current from the signal pins to V_{CC} CABLE when V_{CC} CABLE is open or at GND.
 B. The PMOS transistors prevent backdriving current from the signal pins to V_{CC} CABLE when V_{CC} CABLE is open or at GND. The PMOS transistor is turned off when the associated driver is in the low state.

SN74LVC161284

19-BIT BUS INTERFACE

SCAS583J – NOVEMBER 1996 – REVISED FEBRUARY 2005

absolute maximum ratings over operating free-air temperature range (unless otherwise noted)†

Supply voltage range: V_{CC} CABLE	-0.5 V to 7 V
V_{CC}	-0.5 V to 4.6 V
Input and output voltage range, V_I and V_O : Cable side (see Notes 1 and 2)	-2 V to 7 V
Peripheral side (see Note 1)	-0.5 V to $V_{CC} + 0.5$ V
Input clamp current, I_{IK} ($V_I < 0$)	-20 mA
Output clamp current, I_{OK} ($V_O < 0$)	-50 mA
Continuous output current, I_O : Except PERI LOGIC OUT	± 50 mA
PERI LOGIC OUT	± 100 mA
Continuous current through each V_{CC} or GND	± 200 mA
Output high sink current, I_{SK} ($V_O = 5.5$ V and V_{CC} CABLE = 3 V)	65 mA
Package thermal impedance, θ_{JA} (see Note 3): DGG package	89°C/W
DL package	94°C/W
Storage temperature range, T_{stg}	-65°C to 150°C

† Stresses beyond those listed under “absolute maximum ratings” may cause permanent damage to the device. These are stress ratings only, and functional operation of the device at these or any other conditions beyond those indicated under “recommended operating conditions” is not implied. Exposure to absolute-maximum-rated conditions for extended periods may affect device reliability.

- NOTES: 1. The input and output voltage ratings may be exceeded if the input and output current ratings are observed.
 2. The ac input voltage pulse duration is limited to 40 ns if the amplitude is greater than -0.5 V.
 3. The package thermal impedance is calculated in accordance with JESD 51.

recommended operating conditions (see Note 4)

		MIN	MAX	UNIT
V_{CC} CABLE	Supply voltage for the cable side, V_{CC} CABLE $\geq V_{CC}$	3	5.5	V
V_{CC}	Supply voltage	3	3.6	V
V_{IH}	High-level input voltage	A, B, DIR, and HD	2	V
		C14–C17	2.3	
		HOST LOGIC IN	2.6	
		PERI LOGIC IN	2	
V_{IL}	Low-level input voltage	A, B, DIR, and HD	0.8	V
		C14–C17	0.8	
		HOST LOGIC IN	1.6	
		PERI LOGIC IN	0.8	
V_I	Input voltage	Peripheral side	0	V
		Cable side	V_{CC} 5.5	
V_O	Open-drain output voltage	0	5.5	V
I_{OH}	High-level output current	HD high, B and Y outputs	-14	mA
		A outputs and HOST LOGIC OUT	-4	
		PERI LOGIC OUT	-0.5	
I_{OL}	Low-level output current	B and Y outputs	14	mA
		A outputs and HOST LOGIC OUT	4	
		PERI LOGIC OUT	84	
T_A	Operating free-air temperature	0	70	°C

NOTE 4: All unused inputs of the device must be held at V_{CC} or GND to ensure proper device operation. Refer to the TI application report, *Implications of Slow or Floating CMOS Inputs*, literature number SCBA004.



**electrical characteristics over recommended operating free-air temperature range,
V_{CC} CABLE = 5 V (unless otherwise noted)**

PARAMETER		TEST CONDITIONS	V _{CC}	MIN	TYP†	MAX	UNIT
ΔV _t	Input hysteresis	V _{thH} – V _{thL} for all inputs except the C inputs and HOST LOGIC IN	3.3 V	0.4		V	
		V _{thH} – V _{thL} for the HOST LOGIC IN	3.3 V	0.2			
		V _{thH} – V _{thL} for the C inputs	3.3 V	0.8			
V _{OH}	HD high, B and Y outputs	I _{OH} = –14 mA	3 V	2.23		V	
			3.3 V‡	2.4			
	HD high, A outputs, and HOST LOGIC OUT	I _{OH} = –4 mA	3 V	2.4			
			I _{OH} = –50 μA	3 V	2.8		
	PERI LOGIC OUT	I _{OH} = –0.5 mA	3.15 V	3.1			
			3.3 V‡	4.5			
V _{OL}	B and Y outputs	I _{OL} = 14 mA	3 V	0.77		V	
	A outputs and HOST LOGIC OUT	I _{OL} = 50 μA	3 V	0.2			
		I _{OL} = 4 mA	3 V	0.4			
	PERI LOGIC OUT	I _{OL} = 84 mA	3 V	0.8			
I _I	C inputs	V _I = V _{CC}	3.6 V§	50		μA	
		V _I = GND (pullup resistors)	3.6 V§	–3.5		mA	
	All inputs except the B or C inputs	V _I = V _{CC} or GND	3.6 V	±1		μA	
I _{OZ}	B outputs	V _O = V _{CC}	3.6 V	20		μA	
		V _O = GND (pullup resistors)	3.6 V§	–3.5		mA	
	A1–A8	V _O = V _{CC} or GND	3.6 V	±20		μA	
	Open-drain Y outputs	V _O = GND (pullup resistors)	3.6 V§	–3.5		mA	
I _{off}	Leakage to GND, B and Y outputs	V _I or V _O = 0 to 7 V	0 V	100		μA	
	Leakage to V _{CC} , B and Y outputs			10			
I _{CC} ¶			V _I = V _{CC} , I _O = 0	3.6 V	0.8		mA
			V _I = GND (12 × pullup)	3.6 V	45		
C _i	Control inputs	V _I = V _{CC} or GND	3.3 V	3	4	pF	
C _{io}	All inputs	V _O = V _{CC} or GND	3.3 V	7	15	pF	
Z _O	Cable side	I _{OH} = –35 mA	3.3 V	45		Ω	
R pullup	Cable side	V _O = 0 V (in Hi Z)	3.3 V	1.15	1.65		kΩ

† Typical values are measured at V_{CC} = 3.3 V, V_{CC} CABLE = 5 V, and T_A = 25°C.

‡ V_{CC} CABLE = 4.7 V

§ V_{CC} CABLE = 3.6 V

¶ A maximum current of 170 μA per pin is added to I_{CC} if the pullup resistor pin is above V_{CC}.

SN74LVC161284

19-BIT BUS INTERFACE

SCAS583J – NOVEMBER 1996 – REVISED FEBRUARY 2005

switching characteristics over recommended ranges of supply voltage and operating free-air temperature (unless otherwise noted) (see Figures 1 and 2)

PARAMETER		FROM (INPUT)	TO (OUTPUT)	MIN	TYP†	MAX	UNIT
t _{PLH}	Totem pole	A or B	B or A	1		40	ns
t _{PHL}				1		40	
t _{slew}	Totem pole	Cable-side outputs		0.05		0.4	V/ns
t _{en}	Totem pole	HD	B, Y, and PERI LOGIC OUT	1		25	ns
t _{dis}	Totem pole	HD	B, Y, and PERI LOGIC OUT	1		25	ns
t _{en} -t _{dis}				1		10	ns
t _{en}		DIR	A	1		50	ns
t _{dis}		DIR	A	1		15	ns
			B	1		50	
t _r , t _f	Open drain	A	B or Y			120	ns
t _{sk(o)‡}		A or B	B or A		2.5	10	ns

† Typical values are measured at V_{CC} = 3.3 V, V_{CC CABLE} = 5 V, and T_A = 25°C.

‡ Skew is measured at 1/2 (V_{OH} + V_{OL}) for signals switching in the same direction.

operating characteristics, V_{CC} = 3.3 V, T_A = 25°C

PARAMETER		TEST CONDITIONS	TYP	UNIT	
C _{pd}	Power dissipation capacitance	Outputs enabled	C _L = 0, f = 10 MHz	45	pF



PARAMETER MEASUREMENT INFORMATION

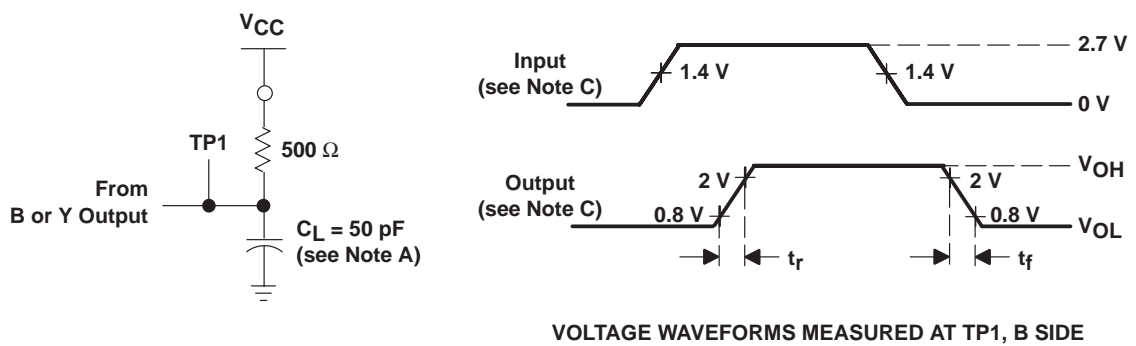
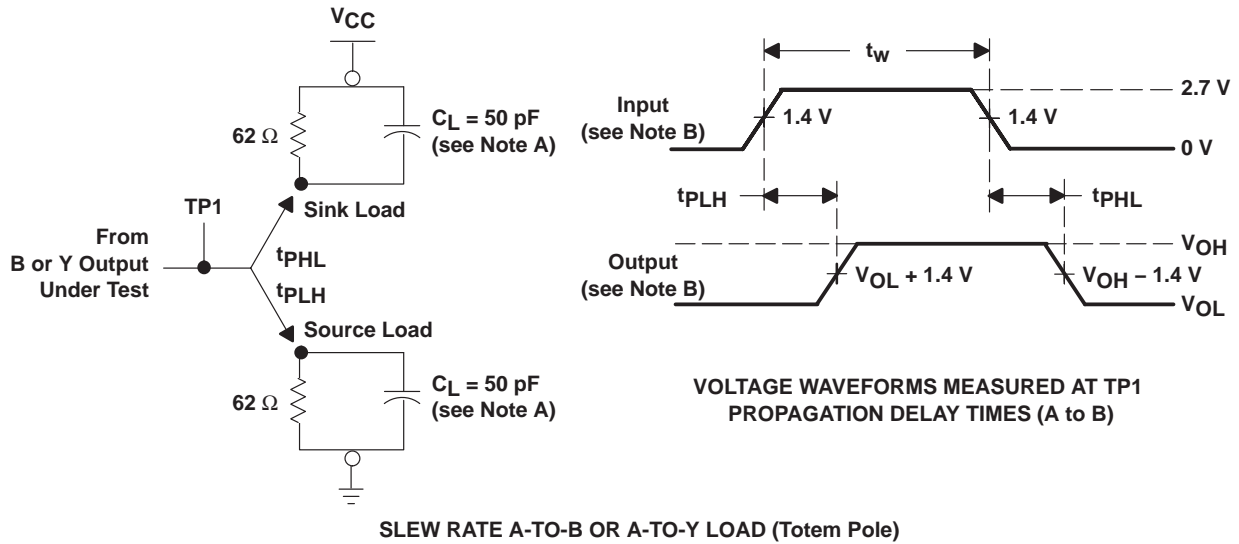

- NOTES: A. C_L includes probe and jig capacitance.
 B. Input rise and fall times are 3 ns, $150 \text{ ns} < \text{pulse duration} < 10 \text{ } \mu\text{s}$ for both low-to-high and high-to-low transitions. Slew rate is measured between 0.4 V and 0.9 V for the rising edge and between 2.4 V and 1.9 V for the falling edge.
 C. Input rise and fall times are 3 ns. Rise and fall times (open drain) $< 120 \text{ ns}$.
 D. The outputs are measured one at a time, with one transition per measurement.

Figure 1. Load Circuits and Voltage Waveforms

SN74LVC161284 19-BIT BUS INTERFACE

SCAS583J – NOVEMBER 1996 – REVISED FEBRUARY 2005

PARAMETER MEASUREMENT INFORMATION

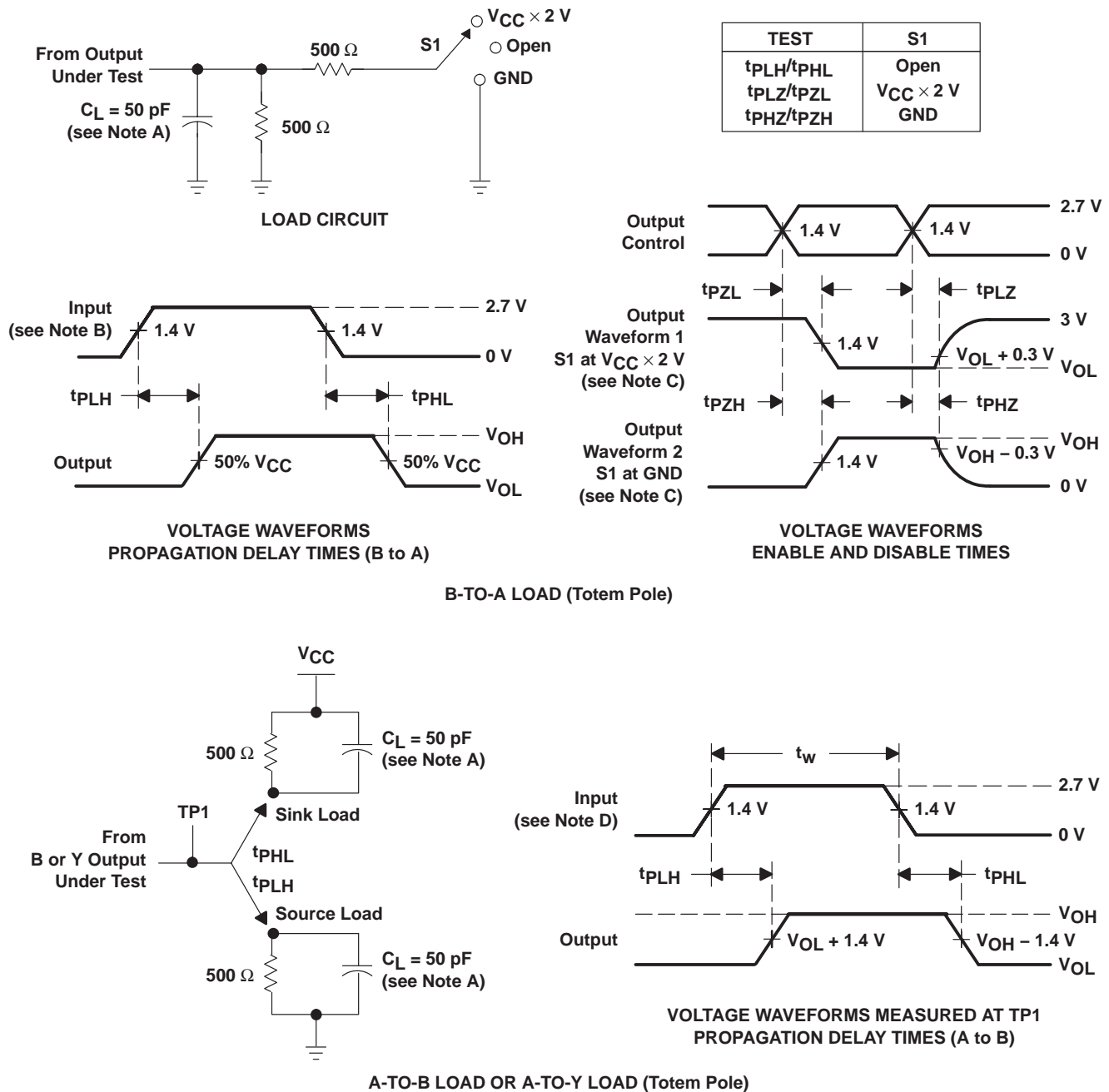

- NOTES:
- C_L includes probe and jig capacitance.
 - Input rise and fall times are 3 ns.
 - Waveform 1 is for an output with internal conditions such that the output is low except when disabled by the output control. Waveform 2 is for an output with internal conditions such that the output is high except when disabled by the output control.
 - Input rise and fall times are 3 ns. Pulse duration is $150 \text{ ns} < t_w < 10 \mu\text{s}$.
 - The outputs are measured one at a time, with one transition per measurement.

Figure 2. Load Circuit and Voltage Waveforms

PACKAGING INFORMATION

Orderable Device	Status ⁽¹⁾	Package Type	Package Drawing	Pins	Package Qty	Eco Plan ⁽²⁾	Lead/Ball Finish	MSL Peak Temp ⁽³⁾
74LVC161284DGGRG4	ACTIVE	TSSOP	DGG	48	2000	Green (RoHS & no Sb/Br)	CU NIPDAU	Level-1-260C-UNLIM
74LVC161284DLRG4	ACTIVE	SSOP	DL	48	1000	Green (RoHS & no Sb/Br)	CU NIPDAU	Level-1-260C-UNLIM
SN74LVC161284DGGR	ACTIVE	TSSOP	DGG	48	2000	Green (RoHS & no Sb/Br)	CU NIPDAU	Level-1-260C-UNLIM
SN74LVC161284DL	ACTIVE	SSOP	DL	48	25	Green (RoHS & no Sb/Br)	CU NIPDAU	Level-1-260C-UNLIM
SN74LVC161284DLG4	ACTIVE	SSOP	DL	48	25	Green (RoHS & no Sb/Br)	CU NIPDAU	Level-1-260C-UNLIM
SN74LVC161284DLR	ACTIVE	SSOP	DL	48	1000	Green (RoHS & no Sb/Br)	CU NIPDAU	Level-1-260C-UNLIM

⁽¹⁾ The marketing status values are defined as follows:

ACTIVE: Product device recommended for new designs.

LIFEBUY: TI has announced that the device will be discontinued, and a lifetime-buy period is in effect.

NRND: Not recommended for new designs. Device is in production to support existing customers, but TI does not recommend using this part in a new design.

PREVIEW: Device has been announced but is not in production. Samples may or may not be available.

OBSOLETE: TI has discontinued the production of the device.

⁽²⁾ Eco Plan - The planned eco-friendly classification: Pb-Free (RoHS), Pb-Free (RoHS Exempt), or Green (RoHS & no Sb/Br) - please check <http://www.ti.com/productcontent> for the latest availability information and additional product content details.

TBD: The Pb-Free/Green conversion plan has not been defined.

Pb-Free (RoHS): TI's terms "Lead-Free" or "Pb-Free" mean semiconductor products that are compatible with the current RoHS requirements for all 6 substances, including the requirement that lead not exceed 0.1% by weight in homogeneous materials. Where designed to be soldered at high temperatures, TI Pb-Free products are suitable for use in specified lead-free processes.

Pb-Free (RoHS Exempt): This component has a RoHS exemption for either 1) lead-based flip-chip solder bumps used between the die and package, or 2) lead-based die adhesive used between the die and leadframe. The component is otherwise considered Pb-Free (RoHS compatible) as defined above.

Green (RoHS & no Sb/Br): TI defines "Green" to mean Pb-Free (RoHS compatible), and free of Bromine (Br) and Antimony (Sb) based flame retardants (Br or Sb do not exceed 0.1% by weight in homogeneous material)

⁽³⁾ MSL, Peak Temp. -- The Moisture Sensitivity Level rating according to the JEDEC industry standard classifications, and peak solder temperature.

Important Information and Disclaimer:The information provided on this page represents TI's knowledge and belief as of the date that it is provided. TI bases its knowledge and belief on information provided by third parties, and makes no representation or warranty as to the accuracy of such information. Efforts are underway to better integrate information from third parties. TI has taken and continues to take reasonable steps to provide representative and accurate information but may not have conducted destructive testing or chemical analysis on incoming materials and chemicals. TI and TI suppliers consider certain information to be proprietary, and thus CAS numbers and other limited information may not be available for release.

In no event shall TI's liability arising out of such information exceed the total purchase price of the TI part(s) at issue in this document sold by TI to Customer on an annual basis.

TAPE AND REEL INFORMATION



QUADRANT ASSIGNMENTS FOR PIN 1 ORIENTATION IN TAPE



*All dimensions are nominal

Device	Package Type	Package Drawing	Pins	SPQ	Reel Diameter (mm)	Reel Width W1 (mm)	A0 (mm)	B0 (mm)	K0 (mm)	P1 (mm)	W (mm)	Pin1 Quadrant
SN74LVC161284DGGR	TSSOP	DGG	48	2000	330.0	24.4	8.6	15.8	1.8	12.0	24.0	Q1
SN74LVC161284DLR	SSOP	DL	48	1000	330.0	32.4	11.35	16.2	3.1	16.0	32.0	Q1

TAPE AND REEL BOX DIMENSIONS



*All dimensions are nominal

Device	Package Type	Package Drawing	Pins	SPQ	Length (mm)	Width (mm)	Height (mm)
SN74LVC161284DGGR	TSSOP	DGG	48	2000	346.0	346.0	41.0
SN74LVC161284DLR	SSOP	DL	48	1000	346.0	346.0	49.0

DGG (R-PDSO-G**)

PLASTIC SMALL-OUTLINE PACKAGE

48 PINS SHOWN



- NOTES: A. All linear dimensions are in millimeters.
 B. This drawing is subject to change without notice.
 C. Body dimensions do not include mold protrusion not to exceed 0,15.
 D. Falls within JEDEC MO-153

IMPORTANT NOTICE

Texas Instruments Incorporated and its subsidiaries (TI) reserve the right to make corrections, modifications, enhancements, improvements, and other changes to its products and services at any time and to discontinue any product or service without notice. Customers should obtain the latest relevant information before placing orders and should verify that such information is current and complete. All products are sold subject to TI's terms and conditions of sale supplied at the time of order acknowledgment.

TI warrants performance of its hardware products to the specifications applicable at the time of sale in accordance with TI's standard warranty. Testing and other quality control techniques are used to the extent TI deems necessary to support this warranty. Except where mandated by government requirements, testing of all parameters of each product is not necessarily performed.

TI assumes no liability for applications assistance or customer product design. Customers are responsible for their products and applications using TI components. To minimize the risks associated with customer products and applications, customers should provide adequate design and operating safeguards.

TI does not warrant or represent that any license, either express or implied, is granted under any TI patent right, copyright, mask work right, or other TI intellectual property right relating to any combination, machine, or process in which TI products or services are used. Information published by TI regarding third-party products or services does not constitute a license from TI to use such products or services or a warranty or endorsement thereof. Use of such information may require a license from a third party under the patents or other intellectual property of the third party, or a license from TI under the patents or other intellectual property of TI.

Reproduction of TI information in TI data books or data sheets is permissible only if reproduction is without alteration and is accompanied by all associated warranties, conditions, limitations, and notices. Reproduction of this information with alteration is an unfair and deceptive business practice. TI is not responsible or liable for such altered documentation. Information of third parties may be subject to additional restrictions.

Resale of TI products or services with statements different from or beyond the parameters stated by TI for that product or service voids all express and any implied warranties for the associated TI product or service and is an unfair and deceptive business practice. TI is not responsible or liable for any such statements.

TI products are not authorized for use in safety-critical applications (such as life support) where a failure of the TI product would reasonably be expected to cause severe personal injury or death, unless officers of the parties have executed an agreement specifically governing such use. Buyers represent that they have all necessary expertise in the safety and regulatory ramifications of their applications, and acknowledge and agree that they are solely responsible for all legal, regulatory and safety-related requirements concerning their products and any use of TI products in such safety-critical applications, notwithstanding any applications-related information or support that may be provided by TI. Further, Buyers must fully indemnify TI and its representatives against any damages arising out of the use of TI products in such safety-critical applications.

TI products are neither designed nor intended for use in military/aerospace applications or environments unless the TI products are specifically designated by TI as military-grade or "enhanced plastic." Only products designated by TI as military-grade meet military specifications. Buyers acknowledge and agree that any such use of TI products which TI has not designated as military-grade is solely at the Buyer's risk, and that they are solely responsible for compliance with all legal and regulatory requirements in connection with such use.

TI products are neither designed nor intended for use in automotive applications or environments unless the specific TI products are designated by TI as compliant with ISO/TS 16949 requirements. Buyers acknowledge and agree that, if they use any non-designated products in automotive applications, TI will not be responsible for any failure to meet such requirements.

Following are URLs where you can obtain information on other Texas Instruments products and application solutions:

Products

Amplifiers	amplifier.ti.com
Data Converters	dataconverter.ti.com
DLP® Products	www.dlp.com
DSP	dsp.ti.com
Clocks and Timers	www.ti.com/clocks
Interface	interface.ti.com
Logic	logic.ti.com
Power Mgmt	power.ti.com
Microcontrollers	microcontroller.ti.com
RFID	www.ti-rfid.com
RF/IF and ZigBee® Solutions	www.ti.com/lprf

Applications

Audio	www.ti.com/audio
Automotive	www.ti.com/automotive
Broadband	www.ti.com/broadband
Digital Control	www.ti.com/digitalcontrol
Medical	www.ti.com/medical
Military	www.ti.com/military
Optical Networking	www.ti.com/opticalnetwork
Security	www.ti.com/security
Telephony	www.ti.com/telephony
Video & Imaging	www.ti.com/video
Wireless	www.ti.com/wireless

Mailing Address: Texas Instruments, Post Office Box 655303, Dallas, Texas 75265
Copyright © 2009, Texas Instruments Incorporated

Looking for pricing, stock, or lifecycle information?

Click below to explore more details on WIN SOURCE:

 [View SN74LVC161284DLR on WIN SOURCE](#)

 [Texas Instruments](#) Information

Optimize Your Supply Chain with WIN SOURCE Solutions

-  Global Sourcing Solution
-  Obsolete Management
-  Cost Control Management
-  Shortage Management
-  Alternative Solution
-  Excess Inventory Management