



**THE DATASHEET OF
ADV7523ABCBZ-P-1RL**



FEATURES

General

- Low power HDMI/DVI transmitter ideal for portable applications
- CEC controller and expanded message buffer (3 messages) reduces system overhead
- Incorporates HDMI 1.3 (x.v.Color) technology
- Compatible with DVI 1.0
- Optional embedded HDCP keys to support HDCP 1.3
- 1.8 V and 1.2 V supplies for ultralow operating power
- Video/audio inputs accept logic levels from 1.8 V to 3.3 V

Digital video

- 80 MHz operation supports all video and graphics resolutions from 480i to 1080i
- Programmable 2-way color-space converter
- Supports RGB, YCbCr, and DDR
- Supports ITU656-based embedded syncs
- Automatic input video format timing detection (CEA-861-E)

Digital audio

- Supports standard S/PDIF for stereo LPCM or compressed audio up to 192 kHz
- 2-channel, uncompressed LPCM I²S audio up to 192 kHz

Special features for easy system design

- On-chip MPU with I²C master to perform EDID reading and HDCP operations; reports HDMI events through interrupts and registers
- 5 V tolerant I²C and HPD I/Os, no extra device needed
- No audio master clock needed for supporting S/PDIF and I²S
- Compatible with [AD9394](#) HDMI companion chip 5 V generator for Hot Plug detection in portable applications

APPLICATIONS

- Cellular handsets
- Digital video cameras
- Digital still cameras
- Personal media players
- Gaming
- DVD players and recorders
- Digital set-top boxes
- HDMI repeater

GENERAL DESCRIPTION

The [ADV7523A](#) is an 80 MHz, High-Definition Multimedia Interface (HDMI™) transmitter with expanded CEC buffer. It supports HDTV formats up to 1080i and computer graphic resolutions up to XGA at 75 Hz.

For more information about the [ADV7523A](#), email: ATV_VideoTx_Apps@analog.com.

Rev. SpB

Document Feedback

Information furnished by Analog Devices is believed to be accurate and reliable. However, no responsibility is assumed by Analog Devices for its use, nor for any infringements of patents or other rights of third parties that may result from its use. Specifications subject to change without notice. No license is granted by implication or otherwise under any patent or patent rights of Analog Devices. Trademarks and registered trademarks are the property of their respective owners.

FUNCTIONAL BLOCK DIAGRAM

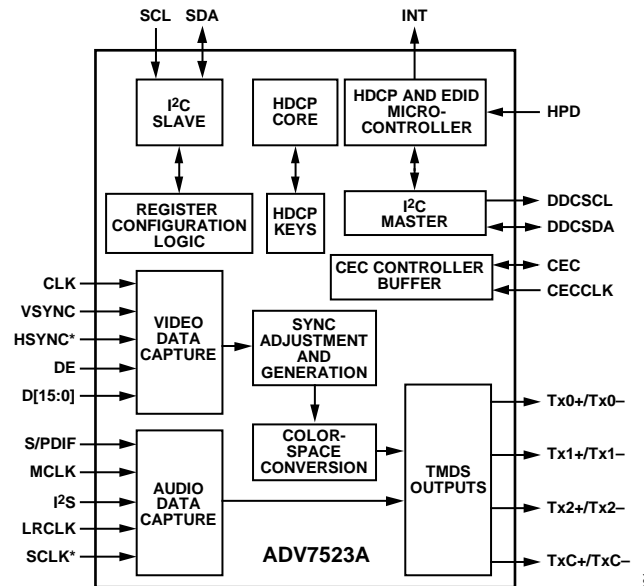

*BOTH HSYNC AND SCLK CAN BE CONFIGURED AS MCLK.

Figure 1.

With the optional inclusion of embedded HDCP keys, the [ADV7523A](#) allows the secure transmission of protected content, as specified by the HDCP 1.3 protocol.

The [ADV7523A](#) supports x.v.Color™ (gamut metadata) for a wider color gamut.

The [ADV7523A](#) supports both S/PDIF and 2-channel I²S audio. Its high fidelity, 2-channel I²S audio can transmit stereo up to a 192 kHz sampling rate. S/PDIF can carry stereo LPCM audio or compressed audio, including Dolby® digital and DTS®.

The [ADV7523A](#) helps to reduce system design complexity and cost by incorporating such features as an I²C master for EDID reading, and 5 V tolerance on the I²C and Hot Plug™ detect pins.

Fabricated in an advanced CMOS process, the [ADV7523A](#) is available in a space saving, 49-ball, WLCSP surface-mount package. This package is RoHS compliant and specified to operate from -25°C to +85°C.

NOTES

I²C refers to a communications protocol originally developed by Philips Semiconductors (now NXP Semiconductors).

Looking for pricing, stock, or lifecycle information?

Click below to explore more details on WIN SOURCE:

- ⊖ [View ADV7523ABCBZ-P-1RL on WIN SOURCE](#)
- ⊖ [Analog Devices Inc. Information](#)

Optimize Your Supply Chain with WIN SOURCE Solutions

- ✓ Global Sourcing Solution
- ✓ Obsolete Management
- ✓ Cost Control Management
- ✓ Shortage Management
- ✓ Alternative Solution
- ✓ Excess Inventory Management