

FEATURES

- 4 inputs, 1 output HDMI/DVI links
- ±8 kV ESD protection on input pins
- HDMI 1.4a receive and transmit compliant
- Supports 250 Mbps to 2.25 Gbps data rates and beyond
- Supports 25 MHz to 225 MHz pixel clocks and beyond
- Fully buffered unidirectional inputs/outputs
- Switchable 50 Ω on-chip input terminations with manual or automatic control on channel switch
- Equalized inputs with low added jitter compensate for more than 20 meters of HDMI cable at 2.25 Gbps
- Loss of signal (LOS) detect circuit on TMDS clock
- Output disable feature for reduced power dissipation
- Bidirectional DDC buffers (SDA and SCL)
- EDID replication reduces component count, while enabling simultaneous access to all HDMI sources
- 5 V combiner provides power to EDID replicator and CEC buffer when local system power is off
- Bidirectional buffered CEC line with integrated pull-up resistors (26 kΩ)
- Hot plug detect pulse low on channel switch with programmable pulse width or direct manual control
- Standards compatible: HDMI, DVI, HDCP, I²C
- 80-lead, 14 mm × 14 mm LQFP RoHS-compliant package

APPLICATIONS

- Advanced television (HDTV) sets
- Projectors
- A/V receivers
- Set-top boxes

GENERAL DESCRIPTION

The **ADV3002** is a complete HDMI™/DVI link switch featuring equalized transition minimized differential signaling (TMDS) inputs, ideal for systems with long cable runs. The **ADV3002** includes bidirectional buffering for the DDC bus and CEC line, with integrated pull-up resistors for the CEC line. Additionally, the **ADV3002** includes an EDID replication function that enables one EDID EEPROM to be shared for all four HDMI ports.

The **ADV3002** is provided in a space-saving, 80-lead LQFP surface-mount, Pb-free plastic package and is specified to operate over the 0°C to 85°C temperature range.

FUNCTIONAL BLOCK DIAGRAM

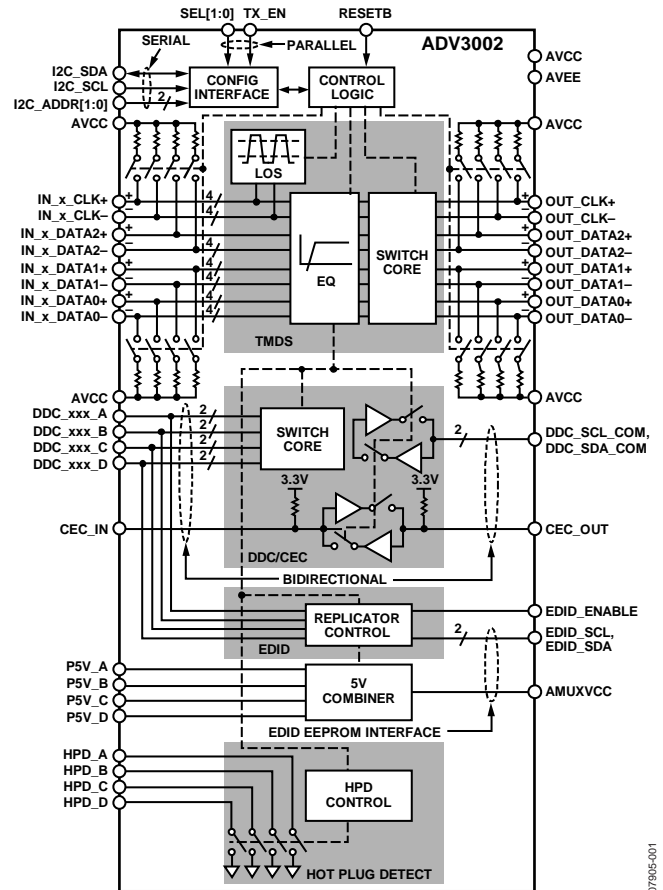

Figure 1.

PRODUCT HIGHLIGHTS

1. Input cable equalizer enables use of long cables at the input. For a 24 AWG cable, the **ADV3002** compensates for more than 20 meters at data rates of up to 2.25 Gbps.
2. Auxiliary multiplexer isolates and buffers the DDC bus and the CEC line, increasing total system capacitance limit.
3. EDID replication eliminates the need for multiple EDID EEPROMs. EDID can be loaded from a single external EEPROM or from a system microcontroller.
4. 5 V power combiner powers the EDID replicator and CEC buffer when local system power is off.
5. Integrated hot plug detect pulse low on channel switch with programmable pulse width or direct manual control.

TABLE OF CONTENTS

Features	1	DDC Buffers.....	13
Applications.....	1	EDID Replication	13
General Description	1	5 V Combiner	15
Functional Block Diagram	1	CEC Buffer	16
Product Highlights	1	Hot Plug Detect Control	16
Revision History	2	Loss of Signal Detect.....	16
Specifications.....	3	Serial Control Interface	17
TMD5 Performance Specifications	3	Reset.....	17
Auxiliary Channel Performance Specifications	3	Write Procedure.....	17
Power Supply and Control Logic Specifications	4	Read Procedure.....	18
Absolute Maximum Ratings.....	5	Register Map	19
Thermal Resistance	5	Applications Information	21
ESD Caution.....	5	HDMI Multiplexer for Advanced TV.....	21
Pin Configuration and Function Descriptions.....	6	Cable Lengths and Equalization.....	24
Typical Performance Characteristics	8	PCB Layout Guidelines.....	24
Theory of Operation	12	Outline Dimensions	27
TMD5 Input Channels.....	12	Ordering Guide	27
TMD5 Output Channels	12		

REVISION HISTORY

8/12—Rev. A to Rev. B

Changed Data Rate = 3 Gbps to	
Data Rate = 2.25 Gbps.....	Throughout
Changes to Features Section and Product Highlights Section ...	1
Changes to Table 1	3
Changes to specifications statements in Typical Performance	
Characteristics Section.....	8
Changes to Theory of Operation Section.....	12
Changes to Cable Lengths and Equalization Section and	
PCB Layout Guidelines Section	24
Added Unused DDC/CEC Buffers Section.....	26

8/11—Rev. 0 to Rev. A

Changed Data Rate = 2.25 Gbps to	
Data Rate = 3 Gbps.....	Throughout
Changes to Features Section and Product Highlights Section	1
Changes to Table 1	3
Changes to Figure 4 Caption and Figure 6 Caption	8
Added Figure 5 and Figure 7; Renumbered Sequentially	8
Moved Figure 8 and Figure 10	9
Changes to Figure 8 Caption and Figure 10 Caption	9
Added Figure 9 and Figure 11	9
Changes to Figure 12 and Figure 15	10
Changes to TMD5 Input Channels Section and TMD5 Output	
Channels Section	12
Changes to Figure 31.....	16
Changes to Cable Lengths and Equalization Section	24

12/08—Revision 0: Initial Version

SPECIFICATIONS

$T_A = 27^\circ\text{C}$, $AVCC = 3.3\text{ V}$, $AMUXVCC = 5\text{ V}$, $AVEE = 0\text{ V}$, data rate = 2.25 Gbps, differential input swing = 1000 mV, TMDS outputs terminated with external $50\ \Omega$ resistors to 3.3 V, unless otherwise noted.

TMDS PERFORMANCE SPECIFICATIONS

Table 1.

Parameter	Test Conditions/Comments	Min	Typ	Max	Unit
DYNAMIC PERFORMANCE					
Maximum Data Rate (DR) per Channel	NRZ	2.25			Gbps
Maximum Clock Rate		225			MHz
Bit Error Rate (BER)	PRBS $2^{23} - 1$			10^{-9}	
Added Data Jitter	$DR \leq 2.25\text{ Gbps}$, PRBS $2^7 - 1$		40		ps p-p
Added Clock Jitter			1		ps rms
Differential Intrapair Skew	At output		1		ps
Differential Interpair Skew	At output		35		ps
EQUALIZATION PERFORMANCE					
High Frequency Gain	Boost frequency = 1.5 GHz		16		dB
INPUT CHARACTERISTICS					
Input Voltage Swing	Differential	150		1200	mV
Input Common-Mode Voltage (V_{ICM})		$AVCC - 800$		$AVCC$	mV
OUTPUT CHARACTERISTICS					
High Voltage Level	Single-ended high speed channel	$AVCC - 200$		$AVCC + 10$	mV
Low Voltage Level	Single-ended high speed channel	$AVCC - 600$		$AVCC - 400$	mV
Rise/Fall time (20% to 80%)	$DR = 2.25\text{ Gbps}$	75		190	ps
TERMINATION					
Input Termination Resistance	Single-ended		50		Ω
Output Termination Resistance	Single-ended		50		Ω
LOSS OF SIGNAL (LOS) DETECT					
Frequency Cutoff	LOS_FC (see Figure 31)	5			MHz
Amplitude Threshold	Clock rate = 225 MHz, LOS_THR = 00 (see Figure 31)		35		mV

AUXILIARY CHANNEL PERFORMANCE SPECIFICATIONS

Table 2.

Parameter	Test Conditions/Comments	Min	Typ	Max	Unit
DDC CHANNELS					
Input Capacitance, C_{AUX}	DC bias = 2.5 V, ac voltage = 3.5 V p-p, $f = 100\text{ kHz}$		5	15	pF
Input Low Voltage, V_{IL}				0.5	V
Input High Voltage, V_{IH}		$0.7 \times AMUXVCC$			V
Output Low Voltage, V_{OL}	$I_{OL} = 5\text{ mA}$		0.25	0.4	V
Rise Time	10% to 90%, $C_{LOAD} = 50\text{ pF}$, $R_{PULL-UP} = 2\text{ k}\Omega$		1.45		μs
Fall Time	90% to 10%, $C_{LOAD} = 50\text{ pF}$, $R_{PULL-UP} = 2\text{ k}\Omega$		20	250	ns
Leakage	$V_{IN} = 5.0\text{ V}$			10	μA

Parameter	Test Conditions/Comments	Min	Typ	Max	Unit
CEC CHANNEL					
Input Capacitance, C_{AUX}	DC bias = 1.65 V, ac voltage = 2.5 V p-p, f = 100 kHz		5	15	pF
Input Low Voltage, V_{IL}				0.8	V
Input High Voltage, V_{IH}		2.0			V
Output Low Voltage, V_{OL}	$I_{OL} = 3$ mA		0.1	0.6	V
Output High Voltage, V_{OH}			2.5		
Rise Time	10% to 90%, $C_{LOAD} = 1500$ pF, $R_{PULL-UP} = 27$ k Ω ; or $C_{LOAD} = 7200$ pF, $R_{PULL-UP} = 3$ k Ω		75	250	μ s
Fall Time	90% to 10%, $C_{LOAD} = 1500$ pF, $R_{PULL-UP} = 27$ k Ω ; or $C_{LOAD} = 7200$ pF, $R_{PULL-UP} = 3$ k Ω		0.2	50	μ s
Pull-Up Resistance			26		k Ω
Leakage	Off-leakage test conditions ¹			1.8	μ A
HOT PLUG DETECT					
Output Low Voltage, V_{OL}	$R_{PU} = 800$ Ω		0.25	0.4	V

¹ Off leakage test conditions are described in the HDMI Compliance Test Specification 1.3c Section 8, Test ID 8-14. To measure CEC leakage, connect the CEC line to 3.63 V via 26 k Ω \pm 5 % resistor with an ammeter in series and with the power mains disabled.

POWER SUPPLY AND CONTROL LOGIC SPECIFICATIONS

Table 3.

Parameter	Test Conditions/Comments	Min	Typ	Max	Unit
POWER SUPPLY					
AVCC	Operating range (3.3 V \pm 10%)	3.0	3.3	3.6	V
P5V_x		4.7	5	5.5	V
AMUXVCC	Output voltage, total load ¹ = 50 mA	4.0	5	5.5	V
QUIESCENT CURRENT					
AVCC	Outputs disabled		40	60	mA
	Outputs enabled		170	150	mA
P5V_x	Main power on		0.5	10	mA
	Main power off		20	30	mA
AMUXVCC	Main power on		20	30	mA
	Main power off		0.5	10	mA
POWER DISSIPATION					
	Outputs disabled		232	381	mW
	Outputs enabled		661	885	mW
I ² C [®] AND LOGIC INPUTS ²					
Input High Voltage, V_{IH}		2.4			V
Input Low Voltage, V_{IL}				1.0	V
I ² C AND LOGIC OUTPUTS ²					
Output High Voltage, V_{OH}	$I_{OH} = -2$ mA		AVCC		V
Output Low Voltage, V_{OL}	$I_{OL} = +2$ mA			0.4	V

¹ The total load current includes current drawn by the ADV3002 as well as external devices powered from the AMUXVCC supply.

² The ADV3002 I²C control and logic input pins are listed as Control in the Type column in Table 6. I²C pins are 5 V tolerant and based on the 3.3 V I²C bus specification.

ABSOLUTE MAXIMUM RATINGS

Table 4.

Parameter	Rating
AVCC to AVEE	3.7 V
P5V_x	5.8 V
AMUXVCC	$AVCC - 0.3 V < AMUXVCC < 5.8 V$
Internal Power Dissipation	1.2 W
TMDS Single-Ended Input Voltage	$AVCC - 1.4 V < V_{IN} < AVCC + 0.3 V$
TMDS Differential Input Voltage	2.0 V
Voltage at TMDS Output	$V_{OUT} < 3.7 V$
DDC Input Voltage	$AVEE - 0.3 V < V_{IN} < AMUXVCC + 0.3 V$
CEC Input Voltage	$AVEE - 0.3 V < V_{IN} < 4.0 V$
I ² C Logic Input Voltage (EDID_SCL, EDID_SDA, I2C_SCL, I2C_SDA)	$AVEE - 0.3 V < V_{IN} < 4.0 V$
Parallel Input Voltage (I2C_ADDR[1:0], RESETB)	$AVEE - 0.3 V < V_{IN} < AMUXVCC + 0.3 V$
Parallel Input Voltage (SEL[1:0], TX_EN)	$AVEE - 0.3 V < V_{IN} < AVCC + 0.3 V$
Storage Temperature Range	-65°C to +125°C
Operating Temperature Range	0°C to +85°C
Junction Temperature	150°C
ESD Protection (HBM) on HDMI Input Pins	±8 kV
ESD Protection (HBM) on All Other Pins	±2.5 kV

Stresses above those listed under Absolute Maximum Ratings may cause permanent damage to the device. This is a stress rating only; functional operation of the device at these or any other conditions above those indicated in the operational section of this specification is not implied. Exposure to absolute maximum rating conditions for extended periods may affect device reliability.

THERMAL RESISTANCE

θ_{JA} is specified for the worst-case conditions; a device soldered in a 4-layer JEDEC circuit board for surface-mount packages. θ_{JC} is specified for the exposed pad soldered to the circuit board with no airflow.

Table 5. Thermal Resistance

Package Type	θ_{JA}	θ_{JC}	Unit
80-Lead LQFP (ST-80-2)	51.3	15.3	°C/W

ESD CAUTION



ESD (electrostatic discharge) sensitive device. Charged devices and circuit boards can discharge without detection. Although this product features patented or proprietary protection circuitry, damage may occur on devices subjected to high energy ESD. Therefore, proper ESD precautions should be taken to avoid performance degradation or loss of functionality.

PIN CONFIGURATION AND FUNCTION DESCRIPTIONS

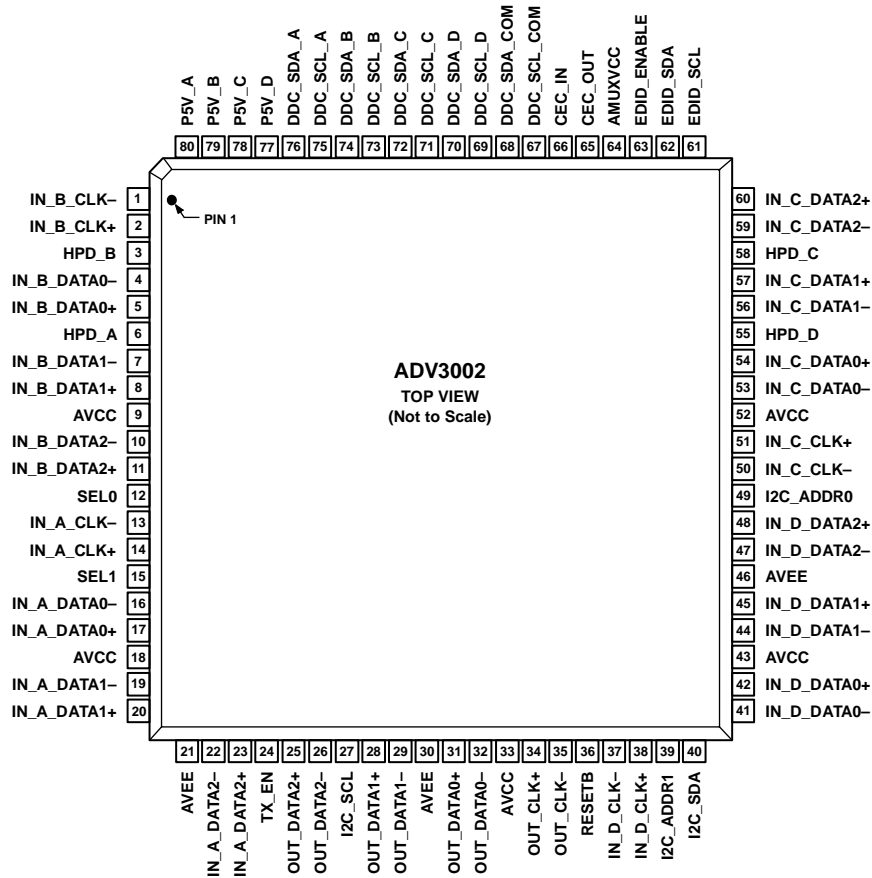

Figure 2. Pin Configuration

Table 6. Pin Function Descriptions

Pin No.	Mnemonic	Type	Description
1	IN_B_CLK-	TMDS	High Speed TMDS Input B Clock Complement.
2	IN_B_CLK+	TMDS	High Speed TMDS Input B Clock.
3	HPD_B	HPD	Hot Plug Detect Output B.
4	IN_B_DATA0-	TMDS	High Speed TMDS Input B Data Complement.
5	IN_B_DATA0+	TMDS	High Speed TMDS Input B Data.
6	HPD_A	HPD	Hot Plug Detect Output A.
7	IN_B_DATA1-	TMDS	High Speed TMDS Input B Data Complement.
8	IN_B_DATA1+	TMDS	High Speed TMDS Input B Data.
9, 18, 33, 43, 52	AVCC	Power	Positive Analog Supply 3.3 V.
10	IN_B_DATA2-	TMDS	High Speed TMDS Input B Data Complement.
11	IN_B_DATA2+	TMDS	High Speed TMDS Input B Data.
12	SEL0	Control	Channel Select Parallel Control LSB.
13	IN_A_CLK-	TMDS	High Speed TMDS Input A Clock Complement.
14	IN_A_CLK+	TMDS	High Speed TMDS Input A Clock.
15	SEL1	Control	Channel Select Parallel Control MSB.
16	IN_A_DATA0-	TMDS	High Speed TMDS Input A Complement.
17	IN_A_DATA0+	TMDS	High Speed TMDS Input A Data.
19	IN_A_DATA1-	TMDS	High Speed TMDS Input A Data Complement.
20	IN_A_DATA1+	TMDS	High Speed TMDS Input A Data.
21, 30, 46	AVEE	Power	Negative Analog Supply 0.0 V.
22	IN_A_DATA2-	TMDS	High Speed TMDS Input A Data Complement.
23	IN_A_DATA2+	TMDS	High Speed TMDS Input A Data.

Pin No.	Mnemonic	Type	Description
24	TX_EN	Control	TMDS Output Enable Parallel Control.
25	OUT_DATA2+	TMDS	High Speed TMDS Output.
26	OUT_DATA2-	TMDS	High Speed TMDS Output Complement.
27	I2C_SCL	Control	Serial Control Clock Input.
28	OUT_DATA1+	TMDS	High Speed TMDS Output.
29	OUT_DATA1-	TMDS	High Speed TMDS Output Complement.
31	OUT_DATA0+	TMDS	High Speed TMDS Output.
32	OUT_DATA0-	TMDS	High Speed TMDS Output Complement.
34	OUT_CLK+	TMDS	High Speed TMDS Output Clock.
35	OUT_CLK-	TMDS	High Speed TMDS Output Clock Complement.
36	RESETB	Control	Configuration Registers Reset. Active low.
37	IN_D_CLK-	TMDS	High Speed TMDS Input D Clock Complement.
38	IN_D_CLK+	TMDS	High Speed TMDS Input D Clock.
39	I2C_ADDR1	Control	Serial Control External Address MSB.
40	I2C_SDA	Control	Serial Control Data Input/Output.
41	IN_D_DATA0-	TMDS	High Speed TMDS Input D Data Complement.
42	IN_D_DATA0+	TMDS	High Speed TMDS Input D Data.
44	IN_D_DATA1-	TMDS	High Speed TMDS Input D Data Complement.
45	IN_D_DATA1+	TMDS	High Speed TMDS Input D Data.
47	IN_D_DATA2-	TMDS	High Speed TMDS Input D Data Complement.
48	IN_D_DATA2+	TMDS	High Speed TMDS Input D Data.
49	I2C_ADDR0	Control	Serial Control External Address LSB.
50	IN_C_CLK-	TMDS	High Speed TMDS Input C Clock Complement.
51	IN_C_CLK+	TMDS	High Speed TMDS Input C Clock.
53	IN_C_DATA0-	TMDS	High Speed TMDS Input C Data Complement.
54	IN_C_DATA0+	TMDS	High Speed TMDS Input C Data.
55	HPD_D	HPD	Hot Plug Detect Output D.
56	IN_C_DATA1-	TMDS	High Speed TMDS Input C Data Complement.
57	IN_C_DATA1+	TMDS	High Speed TMDS Input C Data.
58	HPD_C	HPD	Hot Plug Detect Output C.
59	IN_C_DATA2-	TMDS	High Speed TMDS Input C Data Complement.
60	IN_C_DATA2+	TMDS	High Speed TMDS Input C Data.
61	EDID_SCL	Control	External EDID EEPROM Serial Interface Clock.
62	EDID_SDA	Control	External EDID EEPROM Serial Interface Data.
63	EDID_ENABLE	Control	EDID Replication Enable.
64	AMUXVCC	Power	Positive Power Supply 5.0 V.
65	CEC_OUT	CEC	Consumer Electronics Control Output.
66	CEC_IN	CEC	Consumer Electronics Control Input.
67	DDC_SCL_COM	DDC	Display Data Channel Serial Clock Common Input/Output.
68	DDC_SDA_COM	DDC	Display Data Channel Serial Data Common Input/Output.
69	DDC_SCL_D	DDC	Display Data Channel Serial Clock Input/Output D.
70	DDC_SDA_D	DDC	Display Data Channel Serial Data Input/Output D.
71	DDC_SCL_C	DDC	Display Data Channel Serial Clock Input/Output C.
72	DDC_SDA_C	DDC	Display Data Channel Serial Data Input/Output C.
73	DDC_SCL_B	DDC	Display Data Channel Serial Clock Input/Output B.
74	DDC_SDA_B	DDC	Display Data Channel Serial Data Input/Output B.
75	DDC_SCL_A	DDC	Display Data Channel Serial Clock Input/Output A.
76	DDC_SDA_A	DDC	Display Data Channel Serial Data Input/Output A.
77	P5V_D	Power	5 V HDMI Supply from Source D.
78	P5V_C	Power	5 V HDMI Supply from Source C.
79	P5V_B	Power	5 V HDMI Supply from Source B.
80	P5V_A	Power	5 V HDMI Supply from Source A.

TYPICAL PERFORMANCE CHARACTERISTICS

$T_A = 27^\circ\text{C}$, $AVCC = 3.3\text{ V}$, $AMUXVCC = 5.0\text{ V}$, $AVEE = 0\text{ V}$, differential input swing = 1000 mV, pattern = PRBS $2^7 - 1$, TMDS outputs terminated with external $50\ \Omega$ resistors to 3.3 V, unless otherwise noted.

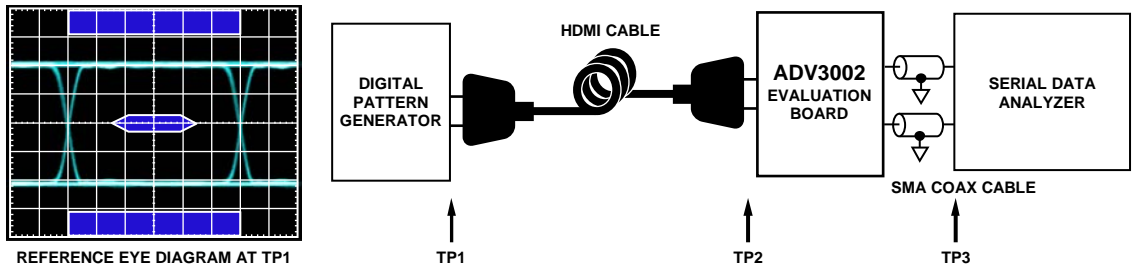

Figure 3. Test Circuit for Eye Diagrams

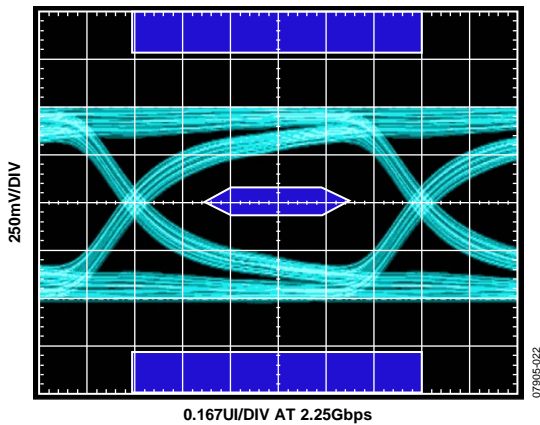

Figure 4. Eye Diagram at TP2 for 2 Meter Cable, Data Rate = 2.25 Gbps

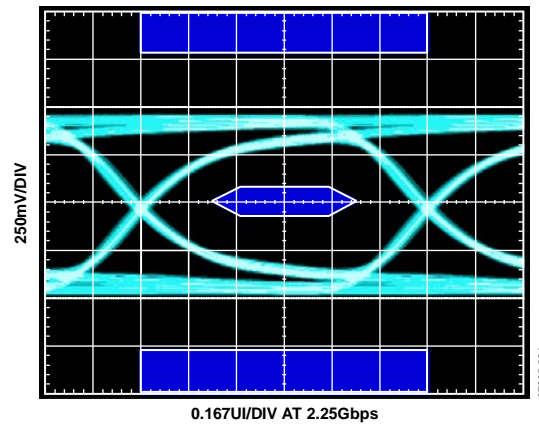

Figure 6. Eye Diagram at TP3 for 2 Meter Cable, Data Rate = 2.25 Gbps

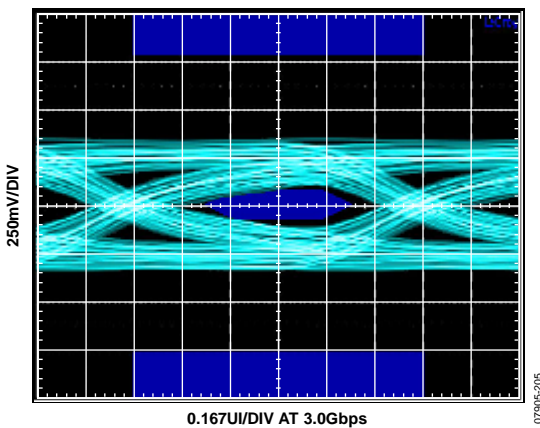

Figure 5. Eye Diagram at TP2 for 2 Meter Cable, Data Rate = 3 Gbps

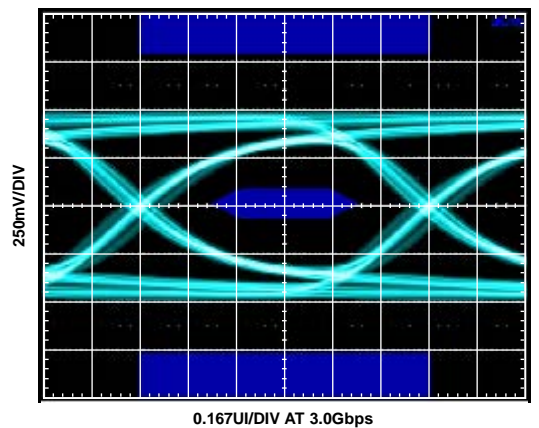

Figure 7. Eye Diagram at TP3 for 2 Meter Cable, Data Rate = 3 Gbps

$T_A = 27^\circ\text{C}$, $AVCC = 3.3\text{ V}$, $AMUXVCC = 5.0\text{ V}$, $AVEE = 0\text{ V}$, differential input swing = 1000 mV, pattern = PRBS $2^7 - 1$, TMD5 outputs terminated with external $50\ \Omega$ resistors to 3.3 V, unless otherwise noted.

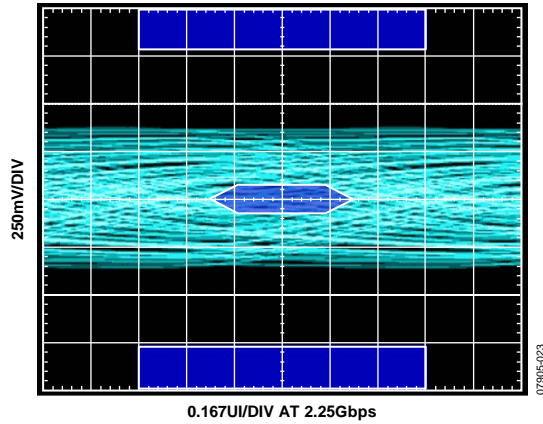

Figure 8. Eye Diagram at TP2 for 20 Meter 24 AWG Cable, Data Rate = 2.25 Gbps

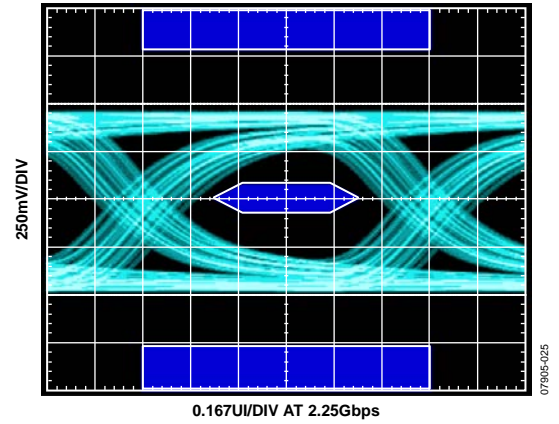

Figure 10. Eye Diagram at TP3 for 20 Meter 24 AWG Cable, Data Rate = 2.25 Gbps

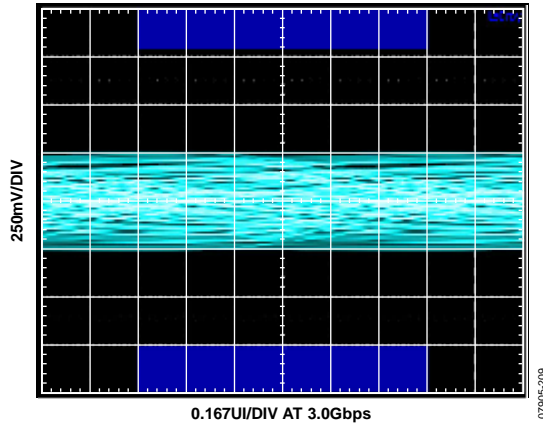

Figure 9. Eye Diagram at TP2 for 15 Meter 24 AWG Cable, Data Rate = 3 Gbps

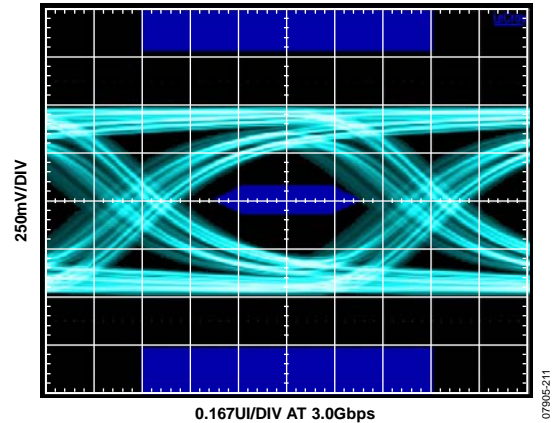

Figure 11. Eye Diagram at TP3 for 15 Meter 24 AWG Cable, Data Rate = 3 Gbps

$T_A = 27^\circ\text{C}$, $AVCC = 3.3\text{ V}$, $AMUXVCC = 5.0\text{ V}$, $AVEE = 0\text{ V}$, differential input swing = 1000 mV, pattern = PRBS $2^7 - 1$, data rate = 2.25 Gbps, TMDS outputs terminated with external $50\ \Omega$ resistors to 3.3 V, unless otherwise noted.

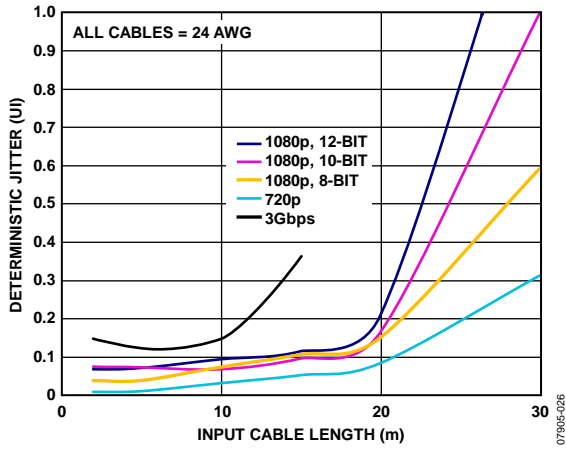

Figure 12. Jitter vs. Input Cable Length

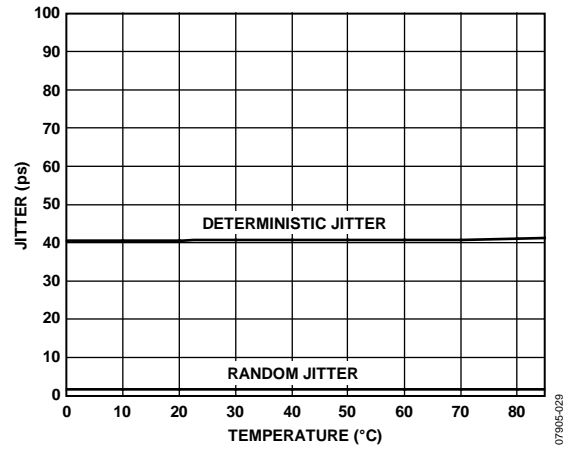

Figure 15. Jitter vs. Temperature

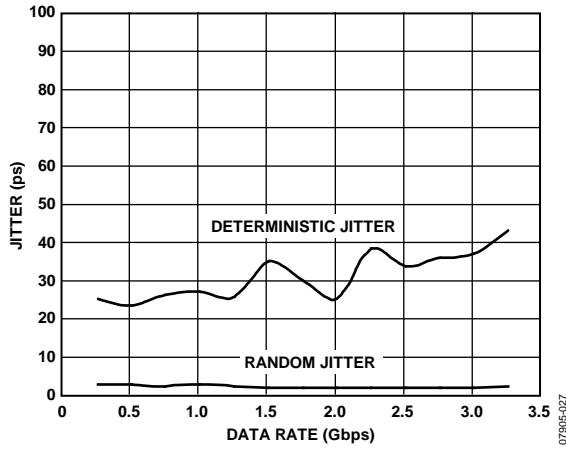

Figure 13. Jitter vs. Data Rate

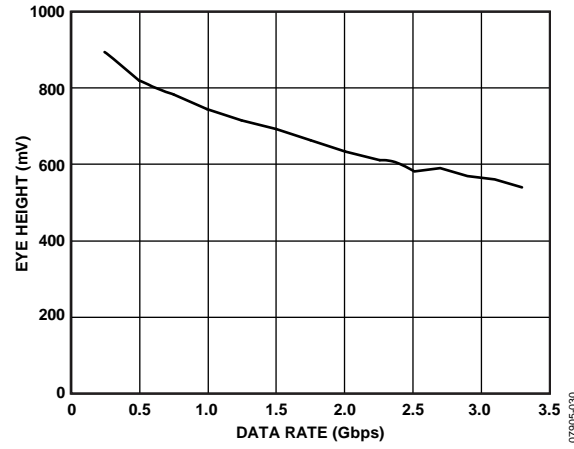

Figure 16. Eye Height vs. Data Rate

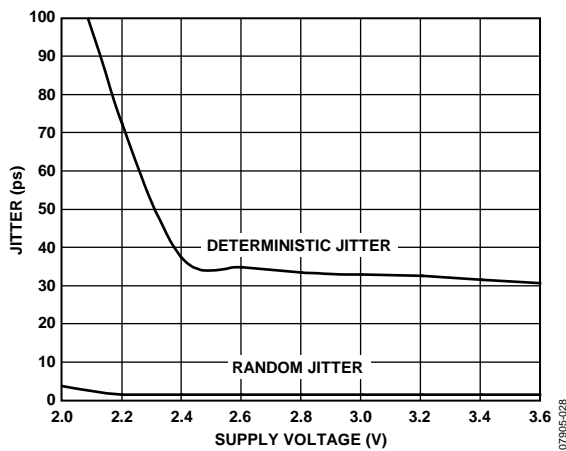

Figure 14. Jitter vs. Supply Voltage

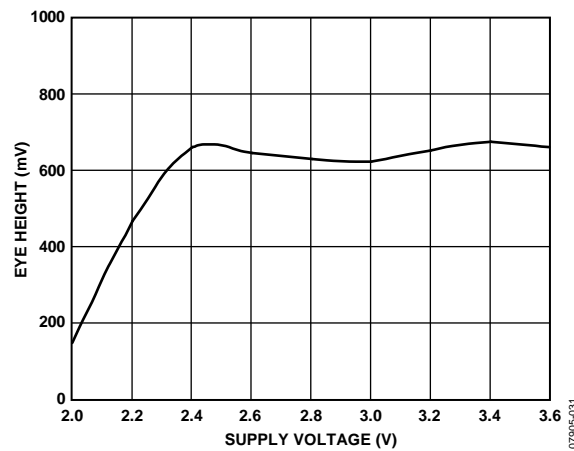

Figure 17. Eye Height vs. Supply Voltage

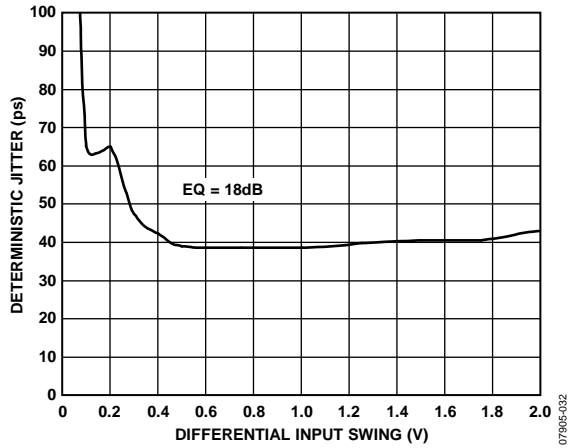

Figure 18. Deterministic Jitter vs. Input Swing

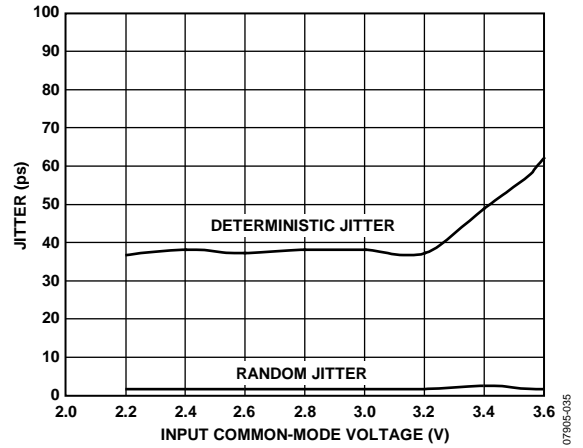

Figure 21. Jitter vs. Input Common-Mode Voltage

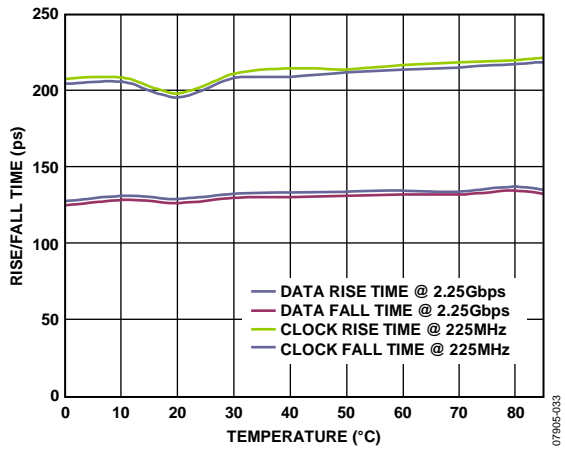

Figure 19. Rise/Fall Time vs. Temperature

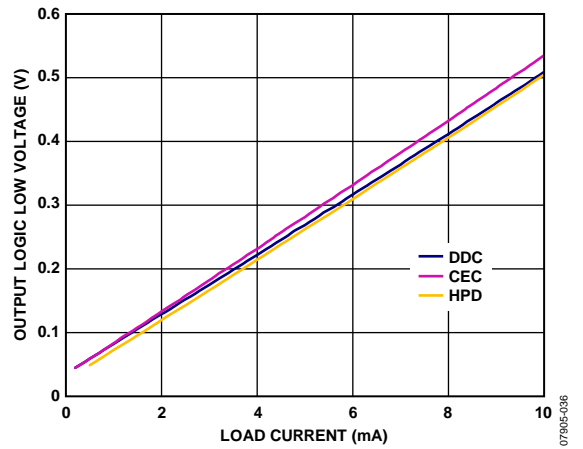

Figure 22. Output Logic Low Voltage vs. Load Current (DDC, CEC, and HPD)

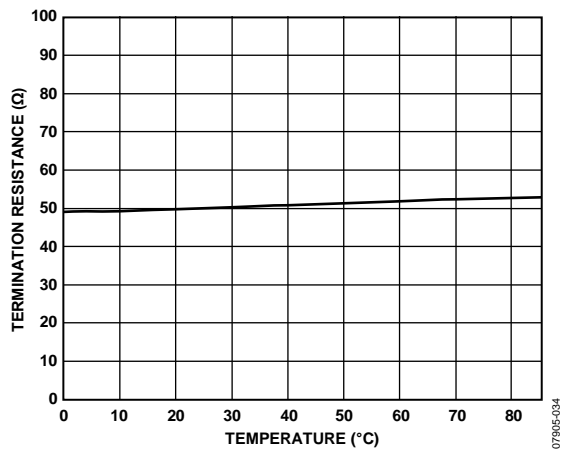

Figure 20. Termination Resistance vs. Temperature

07905-032

07905-038

07905-033

07905-036

07905-034

THEORY OF OPERATION

The primary function of the **ADV3002** is to switch up to four HDMI/DVI sources to one HDMI/DVI sink. Each HDMI/DVI link consists of four differential, high speed channels and four auxiliary single-ended, low speed signals. The high speed channels include a data-word clock and three TMDS data channels running at 10× the data-word clock frequency for data rates up to 2.25 Gbps. The four low speed control signals are the display data channel (DDC) bus (SDA and SCL), the consumer electronics control (CEC) line, and the hot plug detect (HPD) signal.

The **ADV3002** also includes an integrated EDID SRAM, eliminating the need for an external EDID EEPROM for each HDMI connector. A typical HDMI multiplexer is shown in Figure 23. The simplified implementation using the **ADV3002** is shown in Figure 24.

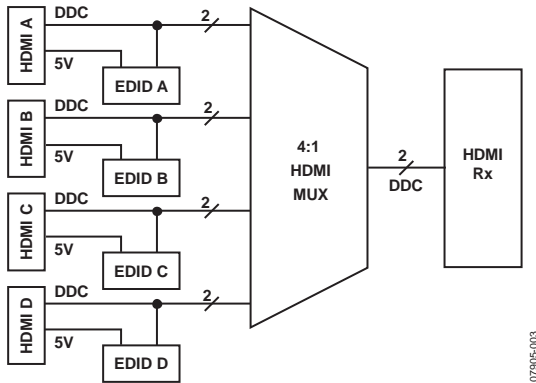

Figure 23. Typical HDMI Multiplexer

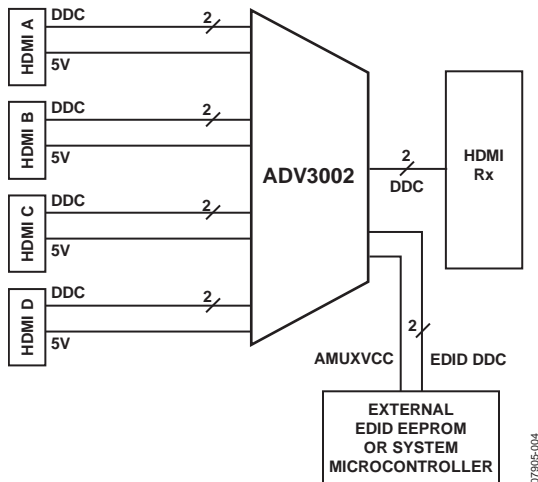
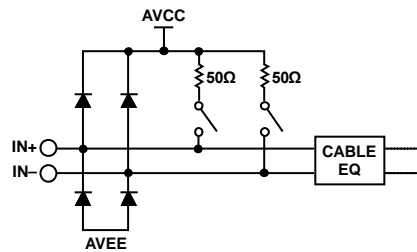

Figure 24. Simplified Implementation Using the **ADV3002**

TMDS INPUT CHANNELS

Each high speed input differential pair terminates to the 3.3 V power supply through a pair of 50 Ω on-chip resistors, as shown in Figure 25. The state of the input terminations can be configured automatically or programmed manually by setting the appropriate bits in the TMDS input termination control register, as shown in Table 10.

The input equalizer can be manually configured to provide two different levels of high frequency boost: 4 dB or 16 dB for 2.25 Gbps data. The equalizer (EQ) level defaults to 16 dB after reset. No specific cable length is suggested for a particular equalization setting because cable performance varies widely between manufacturers; however, in general, the equalization of the **ADV3002** can be set to 16 dB without degrading the signal integrity, even for short input cables.



- NOTES
 1. IN+ REFERS TO IN_x_CLK+/IN_x_DATAx+ PINS.
 2. IN- REFERS TO IN_x_CLK-/IN_x_DATAx- PINS.

Figure 25. High Speed Input Simplified Schematic

TMDS OUTPUT CHANNELS

Each high speed output differential pair is terminated to the 3.3 V power supply through a pair of 50 Ω on-chip resistors, as shown in Figure 26. This termination is user-selectable; it can be turned on or off by programming the TX_OT0 bit of the TMDS output control register, as shown in Table 10.

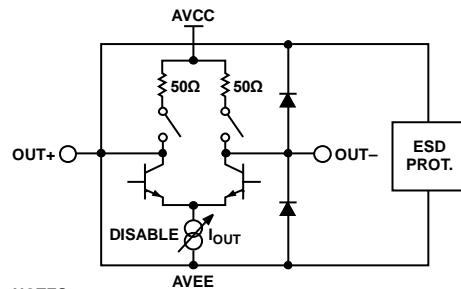

- NOTES
 1. OUT+ REFERS TO OUT_CLK+ AND OUT_DATAx+ PINS.
 2. OUT- REFERS TO OUT_CLK- AND OUT_DATAx- PINS.

Figure 26. High Speed Output Simplified Schematic

The output termination resistors of the **ADV3002** back terminate the output TMDS transmission lines. These back terminations, as recommended in the HDMI 1.4 specification, act to absorb reflections from impedance discontinuities on the output traces, improving the signal integrity of the output traces and adding flexibility to how the output traces can be routed.

For example, interlayer vias can be used to route the ADV3002 TMDS outputs on multiple layers of the printed circuit board (PCB) without severely degrading the quality of the output signal.

The output has a disable feature that places the outputs in tristate mode. Bigger wire-ORed arrays can be constructed using the ADV3002 in this mode.

The ADV3002 requires output termination resistors when the high speed outputs are enabled. Termination can be internal and/or external. The internal terminations of the ADV3002 are enabled by default after reset. External terminations can be provided either by on-board resistors or by the input termination resistors of an HDMI/DVI receiver. If both the internal terminations are enabled and external terminations are present, set the output current level to 20 mA by programming the TX_OCL bit of the TMDS output control register, as shown in Table 10 (20 mA is the default upon reset). If only external terminations are provided (if the internal terminations are disabled), set the output current level to 10 mA by programming the TX_OCL bit of the TMDS output control register. The high speed outputs must be disabled if there are no output termination resistors present in the system.

DDC BUFFERS

The DDC buffers are 5 V tolerant bidirectional lines that carry extended display identification data (EDID) and high bandwidth digital content protection (HDCP) encryption. The ADV3002 provides switching and buffering for the DDC buses. The DDC buffers are bidirectional, and fully support arbitration, clock synchronization, and other relevant features of a standard mode I²C bus.

EDID REPLICATION

The ADV3002 EDID replication feature reduces the total system cost by eliminating the need for an EDID EEPROM for each HDMI port. With the ADV3002, only a single external EDID is necessary. The ADV3002 stores the EDID information in an on-chip SRAM. This enables the EDID information to be simultaneously accessible to all four HDMI ports. The ADV3002 combines the 5 V power from the four HDMI sources such that the EDID information can be available even when the system power is off. A block diagram of the ADV3002 DDC buffering and EDID replication scheme is shown in Figure 27.

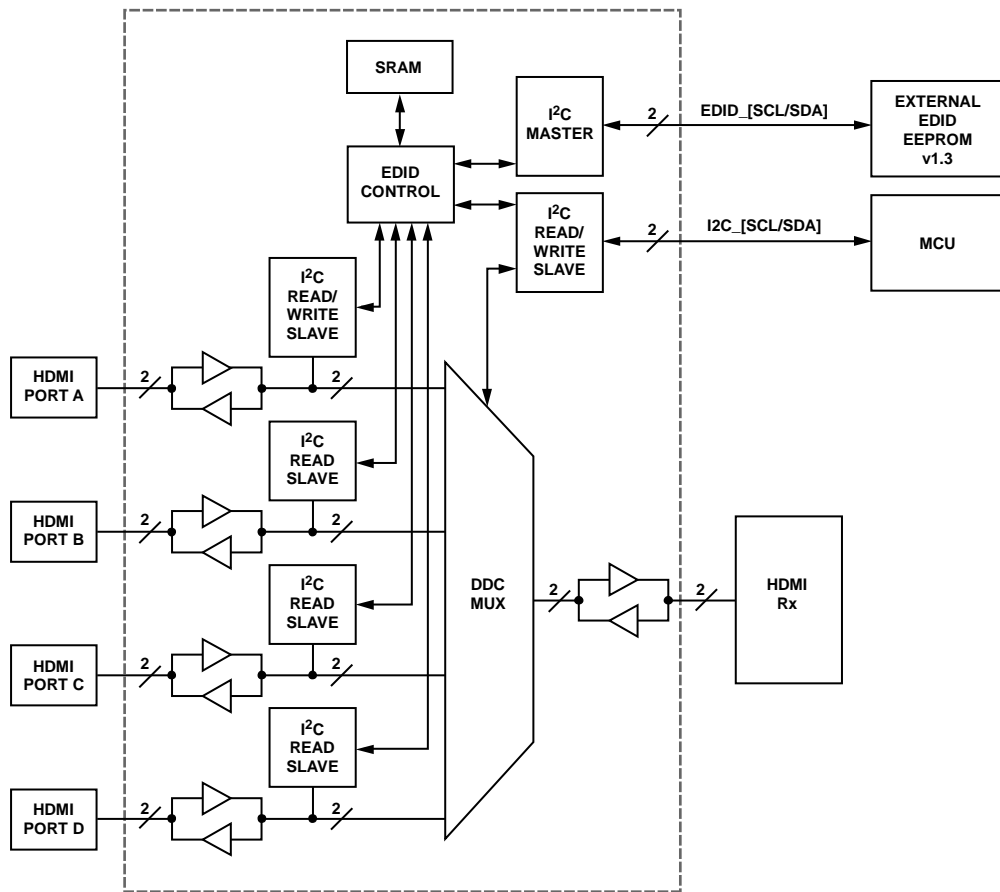

Figure 27. EDID Replication Block Diagram

07905-007

Source Physical Address Assignment

In HDTV applications where the CEC function is available, the EDID contains the source physical address (SPA); a unique value for each HDMI port. Because the memory in the **ADV3002** is volatile, the SPA must be stored in the external EDID EEPROM. Rather than require a larger external EEPROM to store the SPA, because all 256 bytes of memory are needed for typical EDID information, the **ADV3002** takes advantage of EDID information that is always a fixed value, such as the 24-bit IEEE registration identifier (0x000C03). The 24 bits of the IEEE registration identifier are replaced with the desired SPA values. When a source requests the IEEE registration identifier, the **ADV3002** responds with the fixed value (0x000C03). The **ADV3002** then automatically calculates the correct checksum for each port based on the SPA stored for that port in the vendor specific data block (VSDB).

CEC-enabled devices have a source physical address (SPA) that allows the CEC controller to address the specific physical devices and control switches. The SPA is comprised of four fields or nibbles. Each field is a 4-bit number; therefore, each field can be any one of 16 possible values (0x0 through 0xF). Each HDMI input port is assigned a unique SPA as shown in Figure 28. In any CEC-enabled device, only one of the four fields is unique per port. In HDMI sink applications, where the sink is the root device, only the W field is unique per port, whereas the X, Y, and Z fields are always set to zero.

$$SPA = W. X. Y. Z$$

A typical vendor specific data block (VSDB) is shown in Table 7. When using the **ADV3002** EDID replicator, the VSDB should be replaced with the one shown in Table 8, whereby the port specific field can be assigned to any of the four fields (W, X, Y, or Z) depending on the value set in the override select bits as shown in Table 9.

When calculating the checksum for Block 1 of the EDID, do not use the custom values entered in place of the IEEE registration identifier in the calculation; instead, use the IEEE registration identifier values (0x000C03). Include the values in Byte 4 and Byte 5 of the VSDB in the calculation.

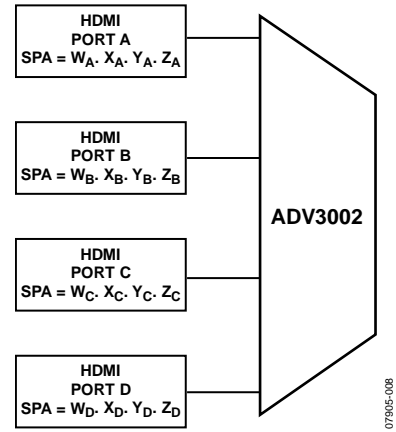

Figure 28. SPA Assignments

Table 7. Typical Vendor Specific Data Block (VSDB)

Byte No.	7	6	5	4	3	2	1	0
0	Vendor specific tag code (= 3)			Length (= N)				
1	24-bit IEEE registration identifier (0x000C03) (least significant byte first)							
2								
3								
4	SPA Field W			SPA Field X				
5	SPA Field Y			SPA Field Z				
6 to N	Remainder or VSDB is stored in Byte 6 through Byte N							

Table 8. Vendor Specific Data Block with **ADV3002**

Byte No.	7	6	5	4	3	2	1	0
0	Vendor specific tag code (= 3)			Length (= N)				
1	Port A SPA override field			Port B SPA override field				
2	Port C SPA override field			Port D SPA override field				
3	Not used			Override select (see Table 9)				
4	Default W field			Default X field				
5	Default Y field			Default Z field				
6 to N	Remainder or VSDB is stored in Byte 6 through Byte N							

Table 9. Override Select Assignment

Bit 3	Override Select			Field Replaced by Port-Specific SPA
	Bit 2	Bit 1	Bit 0	
1	0	0	0	W
0	1	0	0	X
0	0	1	0	Y
0	0	0	1	Z

EDID Replication with External EEPROM

The ADV3002 has dedicated pins to interface to an external EDID EEPROM: EDID_SDA and EDID_SCL. In the default configuration, after the first hot plug event or system power-up, the internal I²C master in the ADV3002 copies the contents of the external EDID EEPROM into the on-chip SRAM. While the EDID is being copied, the HPD signals for all four ports are held low by the ADV3002. A flowchart of the start-up procedure is shown in Figure 29. The entire start-up procedure takes less than 10 ms. The EDID replication feature can be disabled using the EDID_ENABLE pin.

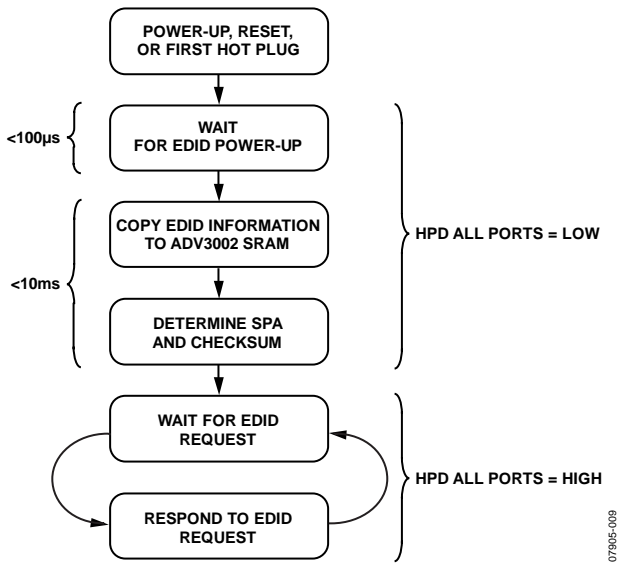

Figure 29. EDID Replication Start-Up Flowchart with External EEPROM

Writing to the EDID EEPROM

The EDID data can be written to the external EEPROM by writing data via the I²C control interface or via the HDMI A DDC inputs. In both cases, the EDID write procedure is as follows:

1. Write Value 0x96 to the EDID EEPROM write protect password register, Register 0x0F. The ADV3002 fixed part address is required to write to this register.
2. Write the EDID data to the EEPROM fixed part address. Data must be written one byte at a time.
3. Write Value 0x00 to the EDID EEPROM write protect password register, Register 0x0F.

EDID Replication with External Microcontroller

The on-chip SRAM can be preloaded using an external microcontroller. Prior to loading the SRAM, disable the I²C master by writing 0x01 to the EDID replication mode register, Register 0x0E. The microcontroller can then write EDID information into the SRAM via the ADV3002 I²C control interface. The writes to the SRAM should be to the fixed part address of 0xA0. When the EDID copy process is complete, enable the EDID replication function by writing 0x00 to the EDID replication mode register (Register 0x0E). The EDID_SDA and EDID_SCL pins are unused when an external microcontroller is used to program the SRAM. These pins can be tied either high or low through a resistor, but should not be left floating.

Reset

Pulling the RESETB pin low initiates a restart of the EDID replication procedure shown in Figure 29 when the local system supply is on. If the local system supply is off, the RESETB pin has no effect.

5 V COMBINER

The 5 V combiner circuit combines the four 5 V supplies from the four HDMI sources and provides the necessary power to the ADV3002 EDID replication circuit, the CEC buffer, as well as the external EDID EEPROM, if applicable. The combiner circuit is designed such that the current limits on each of the 5 V supplies are not exceeded when the local system power is either on or off. A simplified circuit diagram of the 5 V combiner is shown in Figure 30. The combiner detects the presence of the voltage on the 5 V pin (P5V_x) from the HDMI connectors and closes the respective internal switch to connect the 5 V to AMUXVCC. If the local system 3.3 V and 5 V supplies are available, then the combiner opens all the switches.

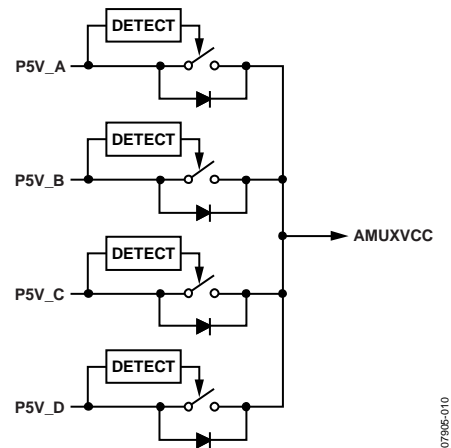

Figure 30. 5 V Combiner Simplified Circuit Diagram

CEC BUFFER

The CEC buffer is bidirectional and includes integrated on-chip pull-up resistors. The CEC buffer isolates capacitance from the PCB and local system microcontroller, which is particularly advantageous in systems where the microcontroller is not placed near the HDMI connectors. The integrated on-chip pull-up resistors are connected to an internal 3.3 V supply that is generated from the AMUXVCC supply; thus, the CEC buffer is fully compliant with the CEC line degradation specifications, when the local system power supply is either on or off.

HOT PLUG DETECT CONTROL

The HPD lines going into the [ADV3002](#) are normally high impedance but are pulled low for greater than 100 ms when a channel switch occurs. This pull-down pulse width can be changed by modifying the value in the hot plug detect pulse width control register (Register 0x05), as shown in Table 10. Also, the HPD pulse can be manually controlled using the hot plug detect manual override control register (Register 0x06), as shown in Table 10.

LOSS OF SIGNAL DETECT

The TMDS clock line of each HDMI input has a loss of signal (LOS) monitor attached to it. The purpose of the LOS monitor is to determine if there is activity in the HDMI link. A simplified circuit diagram of the LOS detector is shown in Figure 31. The LOS monitors are disabled by default. The LOS monitors can be enabled by programming the LOS_EN bit of the LOS detect control register (Register 0x07). When enabled, the status of each HDMI input can be read in the LOS detect status register (Register 0x10). A logic high LOS_STATUS bit of a given HDMI input indicates an inactive input; a logic low LOS_STATUS bit indicates an active input. Three conditions need to be fulfilled for an HDMI input to be considered active:

- The TMDS input termination resistors must be enabled. By default, the [ADV3002](#) TMDS input termination resistors are enabled only on the selected input.
- The TMDS clock frequency exceeds the frequency cutoff (LOS_FC). Refer to Table 1 for the value of the LOS frequency cutoff.
- TMDS clock differential amplitude exceeds the LOS threshold set in the LOS detect control register (Register 0x07). Refer to Table 1 for the value of the LOS amplitude threshold.

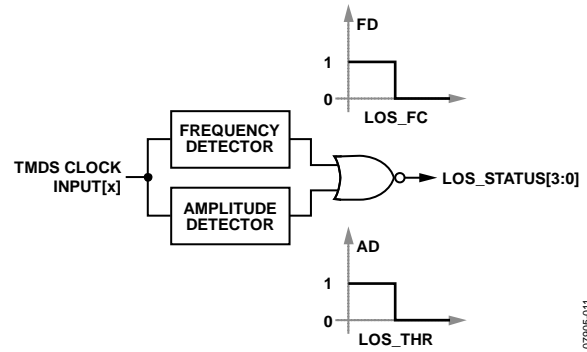

Figure 31. Loss of Signal Detect Simplified Circuit Diagram

LOS Autosquelch

The LOS detect circuit can be used to automatically disable the TMDS signal path. Setting the LOS_RX_EN bit in the LOS control register (Register 0x07) causes the selected TMDS input to be disabled when an LOS event occurs on that input. In this case, the TMDS signal path is enabled when the active signal conditions previously listed are met.

SERIAL CONTROL INTERFACE

RESET

On initial power-up, or at any point in operation, the [ADV3002](#) register set can be restored to the default values by pulling the RESETB pin low according to the specification in Table 3. During normal operation, however, the RESETB pin must be pulled up to 3.3 V.

WRITE PROCEDURE

To write data to the [ADV3002](#) register set, an I²C master (such as a microcontroller) needs to send the appropriate control signals to the [ADV3002](#) slave device. The signals are controlled by the I²C master, unless otherwise specified. For a diagram of the procedure, see Figure 32. The steps for a write procedure are as follows:

1. Send a start condition (while holding the I2C_SCL line high and pulling the I2C_SDA line low).
2. Send the [ADV3002](#) part address (seven bits). The upper five bits of the [ADV3002](#) part address are the static value [10010] and the two LSBs are set by Input Pins I2C_ADDR[1:0]. This transfer should be MSB first.
3. Send the write indicator bit (0).
4. Wait for the [ADV3002](#) to acknowledge the request.
5. Send the register address (eight bits) to which data is to be written. This transfer should be MSB first.
6. Wait for the [ADV3002](#) to acknowledge the request.
7. Send the data (eight bits) to be written to the register whose address was set in Step 5. This transfer should be MSB first.
8. Wait for the [ADV3002](#) to acknowledge the request.
9. Do one of the following:
 - a. Send a stop condition (while holding the I2C_SCL line high and pulling the I2C_SDA line high) and release control of the bus to end the transaction (shown in Figure 32).
 - b. Send a repeated start condition (while holding the I2C_SCL line high and pulling the I2C_SDA line low) and continue from Step 2 in this procedure to perform another write.
 - c. Send a repeated start condition (while holding the I2C_SCL line high and pulling the I2C_SDA line low) and continue from Step 2 of the read procedure (in the Read Procedure section) to perform a read from another address.
 - d. Send a repeated start condition (while holding the I2C_SCL line high and pulling the I2C_SDA line low) and continue from Step 8 of the read procedure (in the Read Procedure section) to perform a read from the same address set in Step 5 of the write procedure.

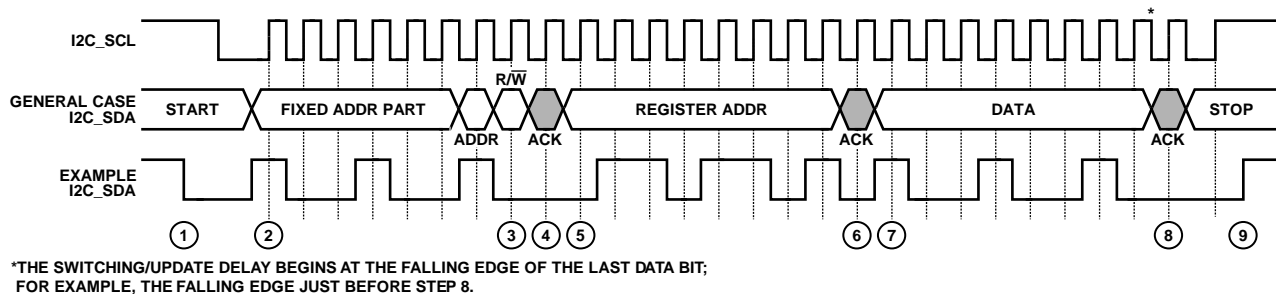

Figure 32. I²C Write Procedure

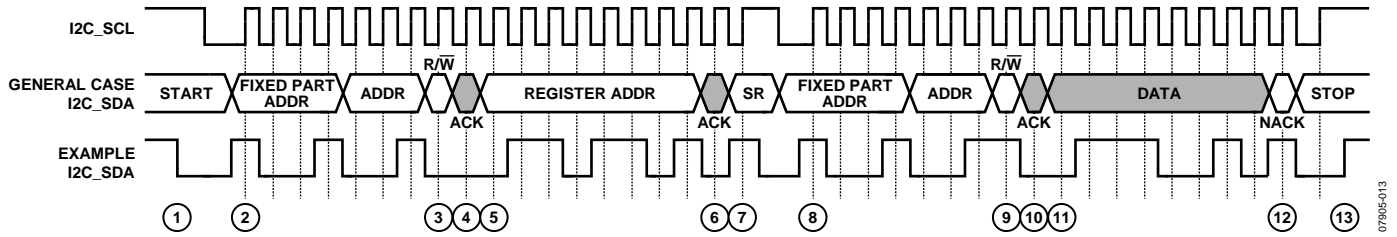

Figure 33. I²C Read Procedure

READ PROCEDURE

To read data from the **ADV3002** register set, an I²C master (such as a microcontroller) needs to send the appropriate control signals to the **ADV3002** slave device. The signals are controlled by the I²C master unless otherwise specified. For a diagram of the procedure, see Figure 33. The steps for a read procedure are as follows:

1. Send a start condition (while holding the I2C_SCL line high and pulling the I2C_SDA line low).
2. Send the **ADV3002** part address (seven bits). The upper five bits of the **ADV3002** part address are the static value [10010] and the two LSBs are set by Input Pins I2C_ADDR[1:0]. This transfer should be MSB first.
3. Send the write indicator bit (0).
4. Wait for the **ADV3002** to acknowledge the request.
5. Send the register address (eight bits) from which data is to be read. This transfer should be MSB first.
6. Wait for the **ADV3002** to acknowledge the request.
7. Send a repeated start condition (SR) by holding the I2C_SCL line high and pulling the I2C_SDA line low.
8. Resend the **ADV3002** part address (seven bits) from Step 2. The upper five bits of the **ADV3002** part address compose the static value [10010]. The two LSBs are set by Input Pins I2C_ADDR[1:0]. This transfer should be MSB first.
9. Send the read indicator bit (1).
10. Wait for the **ADV3002** to acknowledge the request.
11. Read the data from the **ADV3002**. The **ADV3002** serially transfers the data (eight bits) held in the register indicated by the address set in Step 5. This data is sent MSB first.
12. Do one of the following:
 - a. Send a no acknowledge (NACK) followed by a stop condition (while holding the I2C_SCL line high and pulling the SDA line high) and release control of the bus to end the transaction (shown in Figure 33).
 - b. Send a no acknowledge (NACK) followed by a repeated start condition (while holding the I2C_SCL line high and pulling the I2C_SDA line low) and continue from Step 2 of the write procedure (see the previous Write Procedure section) to perform a write.
 - c. Send a no acknowledge (NACK) followed by a repeated start condition (while holding the I2C_SCL line high and pulling the I2C_SDA line low) and continue from Step 2 of this procedure to perform a read from another address.
 - d. Send a no acknowledge (NACK) followed by a repeated start condition (while holding the I2C_SCL line high and pulling the I2C_SDA line low) and continue from Step 8 of this procedure to perform a read from the next byte.
 - e. Send an acknowledge (ACK) and read the next byte of data. Continue from Step 11.
13. Send a stop condition (while holding the I2C_SCL line high and pulling the I2C_SDA line high).

REGISTER MAP

Table 10. Register Map

Address	Default	Register Name	Bit	Bit Name	Description
0x00	0x00	Channel select control	7:3	Unused	Unused
			2	CH_SRC	0: input selected by SEL[1:0] parallel pins 1: input selected by channel select control register, CH[1:0] channel select
			1:0	CH[1:0] channel select	00: Input A selected if CH_SRC = 1 01: Input B selected if CH_SRC = 1 10: Input C selected if CH_SRC = 1 11: Input D selected if CH_SRC = 1
0x01	0x07	TMDS output control	7:4	Unused	Unused
			3	TX_EN_SRC	0: TMDS output enable controlled by the TX_EN parallel pin 1: TMDS output enable controlled by the TX_EN bit
			2	TX_EN	0: TMDS output disabled if TX_EN_SRC = 1 1: TMDS output enabled if TX_EN_SRC = 1
			1	TX_OCL	0: TMDS output current = 10 mA 1: TMDS output current = 20 mA
			0	TX_OTO	0: TMDS output termination = off 1: TMDS output termination = on
0x02	0x02	TMDS input control	7:2	Unused	Unused
			1	EQ_SEL	0: TMDS equalizer boost = 6 dB 1: TMDS equalizer boost = 18 dB
			0	ISIGN	0: TMDS input polarity = standard 1: TMDS input polarity = inverse
0x03	0x0F	TMDS input termination control	7:4	ITO_SRC[3:0]	0000: input termination control is automatic 1111: input termination control is manual
			3:0	ITO_CTL[3:0]	0000: all input terminations off if input termination control is manual 0001: Input A termination on if input termination control is manual 0010: Input B termination on if input termination control is manual 0100: Input C termination on if input termination control is manual 1000: Input D termination on if input termination control is manual 1111: all input terminations on if input termination control is manual
0x04	0x07	Auxiliary buffer enables	7:3	Unused	Unused
			2	Reserved	Reserved; set to 1
			1	DDC_EN	0: DDC buffer disabled 1: DDC buffer enabled
			0	CEC_EN	0: CEC buffer disabled 1: CEC buffer enabled
0x05	0x05	Hot plug detect pulse width control	7:0	HPD_PW[7:0]	Pulse width = decimal (HPD_PW) × step size (24 ms typical)

Address	Default	Register Name	Bit	Bit Name	Description
0x06	0x00	Hot plug detect manual override control	7:5	Unused	Unused
			4	HPD_SRC	0: hot plug detect control is automatic; pulse width set by hot plug detect pulse width control register 1: hot plug detect control is manual; hot plug detect state is set by HPD_CTL[3:0]
			3:0	HPD_CTL[3:0]	0000: HPD outputs are high impedance (pulled up to 5 V via external resistor) 0001: HPD_A = low if HPD_SRC = 1 0010: HPD_B = low if HPD_SRC = 1 0100: HPD_C = low if HPD_SRC = 1 1000: HPD_D = low if HPD_SRC = 1 1111: all HPD outputs = low if HPD_SRC = 1
0x07	0x00	Loss of signal detect control	7:6	Unused	Unused
			5:4	LOS_THR[1:0]	00: LOS Threshold 0 01: LOS Threshold 1 10: LOS Threshold 2 11: LOS Threshold 3
			3	Unused	Unused
			2	LOS_RX_EN	0: TMDS autosquelch disabled 1: TMDS autosquelch enabled
			1	Reserved	Reserved; set to 0
			0	LOS_EN	0: LOS detect disabled 1: LOS detect enabled
0x0E	0x00	EDID replication mode (write only)	7:1	Unused	Unused
			0	EDID_REPL_EN (write only)	0: EDID replicator enabled; for use with an external EEPROM 1: EDID replicator disabled; external microcontroller can write the SRAM; write only
0x0F	0x00	EDID EEPROM write protect password (write only)	7:0	PASSWD[7:0] (write only)	0x00: write protect enabled; EDID EEPROM writes not allowed 0x96: write protect disabled; EDID EEPROM writes from Port A or I ² C control are allowed; write only
0x10	0x00	Loss of signal detect status	7:4	Unused	Unused
			3:0	LOS_STATUS[3:0] (read only)	0000: TMDS active on all inputs 0001: loss of signal detected on Input A 0010: loss of signal detected on Input B 0100: loss of signal detected on Input C 1000: loss of signal detected on Input D 1111: loss of signal detected on all inputs
0xFE	0x03	Revision	7:0	REV[7:0] (read only)	0x03: read only
0xFF	0xC2	Device ID	7:0	ID[7:0] (read only)	0xC2: read only

APPLICATIONS INFORMATION

HDMI MULTIPLEXER FOR ADVANCED TV

The **ADV3002** is a complete HDMI/DVI link switch featuring equalized TMDS inputs, ideal for systems with long cable runs. The **ADV3002** includes bidirectional buffering for the DDC bus and CEC line, with integrated pull-up resistors for the CEC line. Additionally, the **ADV3002** includes an EDID replication function that enables one EDID EEPROM to be shared for all four HDMI ports. Alternatively, a system standby microcontroller can be used instead of a dedicated EDID EEPROM to load the **ADV3002** SRAM. Simplified application schematics are shown in Figure 37 and Figure 38 illustrating these two options.

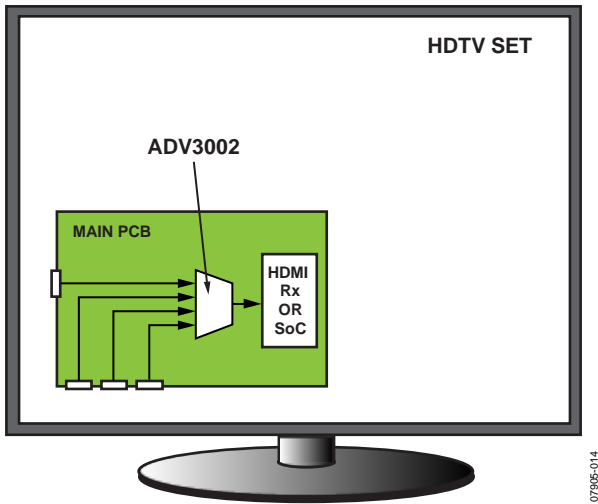

Figure 34. **ADV3002** as an HDMI Multiplexer in an HDTV

TMDS Signals

TMDS signals can be routed from an HDMI connector directly to the inputs of the **ADV3002**. Additional components are not required for the TMDS signals.

DDC Signals

For the DDC input signals, 47 k Ω pull-up resistors to 5 V are recommended.

CEC Signal

The CEC buffer in the **ADV3002** provides a fully compliant input in situations where a general-purpose microcontroller is used to interpret CEC commands. The rise time of the CEC buffer is set by the time constant of the pull-up resistance and the capacitance on the node. A 2 k Ω pull-up resistor to 3.3 V is recommended for optimal output rise times. If a 3.3 V is not available when the system power is off, a Thevenin equivalent 2 k Ω pull-up resistor to 3.3 V is shown in Figure 35.

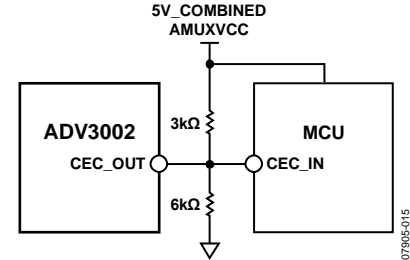

Figure 35. CEC Circuit

5 V Power

The individual 5 V power from each HDMI source can be routed to the respective 5 V inputs of the **ADV3002**. The **ADV3002** combines these four 5 V supplies into one labeled AMUXVCC to support EDID replication and CEC functionality when the local system power is off. An internal 5 V supply must be provided so that power is not drawn from the HDMI sources when the local system power is on. When the local supply is off, this internal 5 V should be high impedance. This can be assured by using a Schottky diode, as shown in Figure 36.

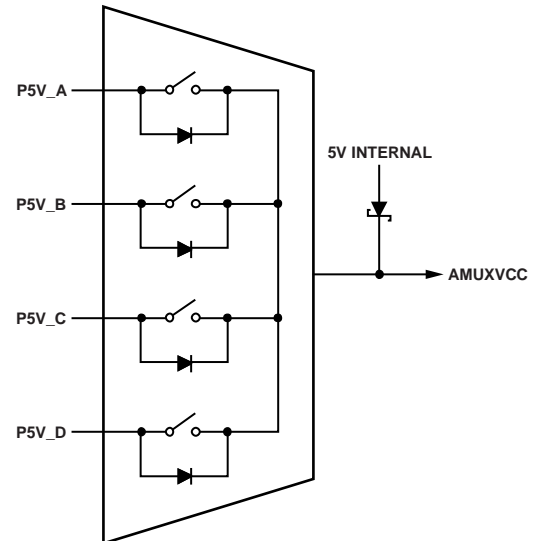

Figure 36. 5 V Power Connections

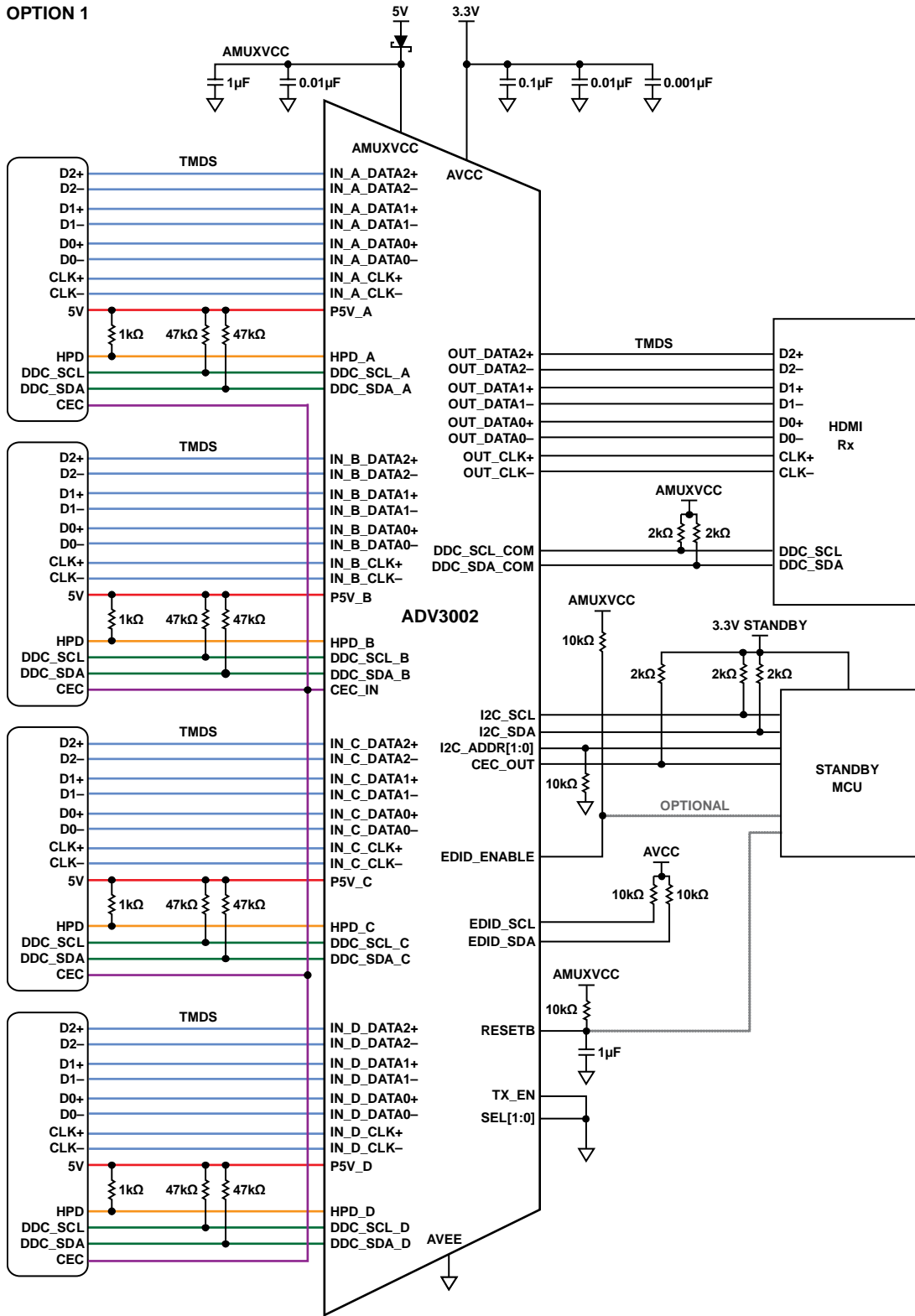

Figure 37. Simplified Application Circuit Diagram (Option 1—No External EEPROM)

07985-017

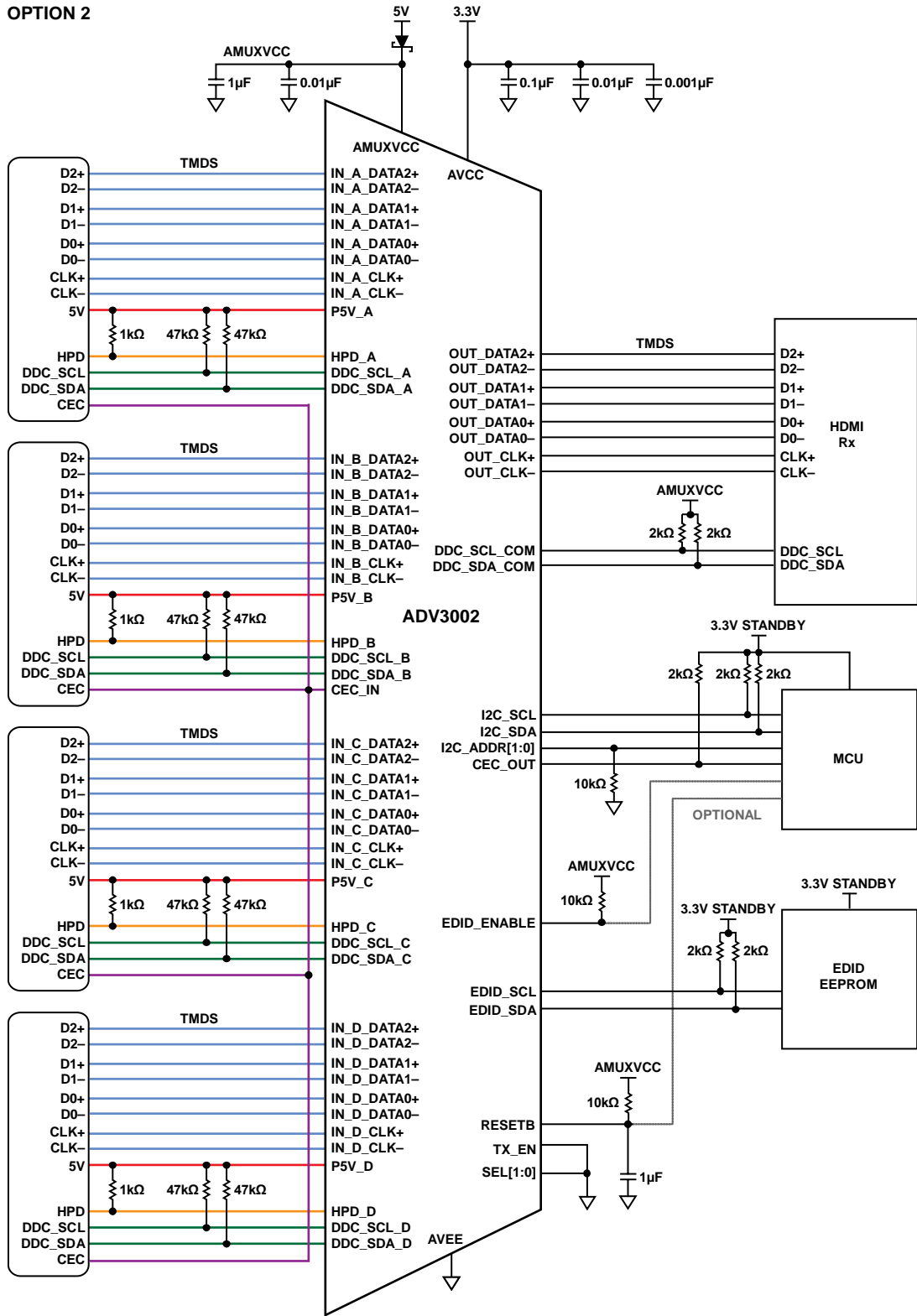

Figure 38. Simplified Application Diagram (Option 2—External EDID EEPROM)

07905-018

CABLE LENGTHS AND EQUALIZATION

The [ADV3002](#) offers two levels of programmable equalization for the high speed inputs: 4 dB and 16 dB. The equalizer of the [ADV3002](#) supports video data rates of up to 2.25 Gbps and can equalize more than 15 meters of 24 AWG HDMI cable at 2.25 Gbps, which corresponds to the video format, 1080p with 12-bit Deep Color. The length of cable that can be used in a typical HDMI/ DVI application depends on a large number of factors including

- Cable quality: the quality of the cable in terms of conductor wire gauge and shielding. Thicker conductors have lower signal degradation per unit length.
- Data rate: the data rate being sent over the cable. The signal degradation of HDMI cables increases with data rate.
- Edge rates: the edge rates of the source input. Slower input edges result in more significant data eye closure at the end of a cable.
- Receiver sensitivity: the sensitivity of the terminating receiver.

As such, no particular equalizer setting is recommended for specific cable types or lengths. In nearly all applications, the [ADV3002](#) equalization level can be set to high, or 18 dB, for all input cable configurations at all data rates, without degrading the signal integrity.

PCB LAYOUT GUIDELINES

The [ADV3002](#) switches two distinctly different types of signals, both of which are required for HDMI and DVI video. These signal groups require different treatment when laying out a PCB.

The first group of signals carries the A/V data. HDMI/DVI video signals are differential, unidirectional, and high speed (up to 2.25 Gbps). The channels that carry the video data must be controlled impedance, terminated at the receiver, and capable of operating up to at least 2.25 Gbps. It is especially important to note that the differential traces that carry the TMDS signals should be designed with a controlled differential impedance of 100 Ω . The [ADV3002](#) provides single-ended 50 Ω terminations on-chip for both its inputs and outputs, and both the input and output terminations can be enabled or disabled through the serial interface. Output termination is recommended but not required by the HDMI standard but its inclusion improves the overall system signal integrity.

The A/V data carried on these high speed channels is encoded by a technique called TMDS, and in the case of HDMI, is also encrypted according to the HDCP standard.

The second group of signals consists of low speed auxiliary control signals used for communication between a source and a sink. Depending upon the application, these signals can include the DDC bus (this is an I²C bus used to send EDID information and HDCP encryption keys between the source and the sink), the CEC line, and the HPD line. These auxiliary signals are bidirectional, low speed, and transferred over a single-ended

transmission line that does not need to have controlled impedance. The primary concern with laying out the auxiliary lines is ensuring that they conform to the I²C bus standard and do not have excessive capacitive loading.

TMDS Signals

In the HDMI/DVI standard, four differential pairs carry the TMDS signals. In DVI, three of these pairs are dedicated to carrying RGB video and sync data. For HDMI, audio data interleaves with the video data; the DVI standard does not incorporate audio information. The fourth high speed differential pair is used for the A/V data-word clock, and runs at one-tenth the speed of the TMDS data channels.

The [ADV3002](#) buffers the TMDS signals, and the input traces can be considered electrically independent of the output traces. In most applications, the quality of the signal on the input TMDS traces are more sensitive to the PCB layout. Regardless of the data being carried on a specific TMDS channel, or whether the TMDS line is at the input or the output of the [ADV3002](#), all four high speed signals should be routed on a PCB in accordance with the same RF layout guidelines.

Layout for the TMDS Signals

The TMDS differential pairs can be either microstrip traces (routed on the outer layer of a board) or stripline traces (routed on an internal layer of the board). If microstrip traces are used, there should be a continuous reference plane on the PCB layer directly below the traces. If stripline traces are used, they must be sandwiched between two continuous reference planes in the PCB stack-up. Additionally, the p and n of each differential pair must have a controlled differential impedance of 100 Ω . The characteristic impedance of a differential pair is a function of several variables including the trace width, the distance separating the two traces, the spacing between the traces and the reference plane, and the dielectric constant of the PCB binder material. Interlayer vias introduce impedance discontinuities that can cause reflections and jitter on the signal path; therefore, it is preferable to route the TMDS lines exclusively on one layer of the board, particularly for the input traces. Additionally, to prevent unwanted signal coupling and interference, route the TMDS signals away from other signals and noise sources on the PCB.

Both traces of a given differential pair must be equal in length to minimize intrapair skew. Maintaining the physical symmetry of a differential pair is integral to ensuring its signal integrity; excessive intrapair skew can introduce jitter through duty cycle distortion (DCD). Always route the p and n of a given differential pair together to establish the required 100 Ω differential impedance. Leave enough space between the differential pairs of a given group to prevent the n of one pair from coupling with the p of another pair. For example, one technique is to make the interpair distance four to 10 times wider than the intrapair spacing.

Any one group of four TMDS traces (Input A, Input B, Input C, Input D, or the output) should have closely matched trace lengths to minimize interpair skew. Severe interpair skew can cause the data on the four different channels of a group to arrive out of alignment with one another. A good practice is to match the trace lengths for a given group of four channels to within 0.05 inches on FR4 material.

Minimizing intrapair and interpair skew becomes increasingly important as data rates increase. Any introduced skew constitutes a correspondingly larger fraction of a bit period at higher data rates.

Though the [ADV3002](#) features input equalization and output preemphasis, minimizing the length of the TMDS traces is needed to reduce overall system signal degradation. Commonly used PCB material, such as FR4, is lossy at high frequencies; therefore, long traces on the circuit board increase signal attenuation, resulting in decreased signal swing and increased jitter through intersymbol interference (ISI).

Controlling the Characteristic Impedance of a TMDS Differential Pair

The characteristic impedance of a differential pair depends on a number of variables, including the trace width, the distance between the two traces, the height of the dielectric material between the trace and the reference plane below it, and the dielectric constant of the PCB binder material. To a lesser extent, the characteristic impedance also depends upon the trace thickness and the presence of solder mask. Many combinations can produce the correct characteristic impedance. Generally, working with the PCB fabricator is required to obtain a set of parameters to produce the desired results.

One consideration is how to guarantee a differential pair with a differential impedance of 100 Ω over the entire length of the trace. One technique to accomplish this is to change the width of the traces in a differential pair based on how closely one trace is coupled to the other. When the two traces of a differential pair are close and strongly coupled, they should have a width that produces a 100 Ω differential impedance. When the traces split apart to go into a connector, for example, and are no longer so strongly coupled, the width of the traces need to be increased to yield a differential impedance of 100 Ω in the new configuration.

Ground Current Return

In some applications, it can be necessary to invert the output pin order of the [ADV3002](#). This requires a designer to route the TMDS traces on multiple layers of the PCB. When routing differential pairs on multiple layers, it is necessary to also reroute the corresponding reference plane to provide one continuous ground current return path for the differential signals. Standard plated through-hole vias are acceptable for both the TMDS traces and the reference plane. An example of this is illustrated in Figure 39.

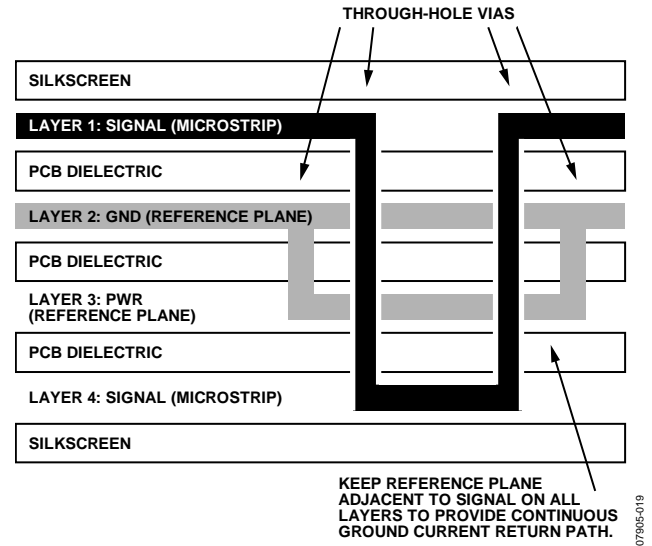

Figure 39. Example Routing of Reference Plane

TMDS Terminations

The [ADV3002](#) provides internal 50 Ω single-ended terminations for all of its high speed inputs and outputs. It is not necessary to include external termination resistors for the TMDS differential pairs on the PCB.

The output termination resistors of the [ADV3002](#) back terminate the output TMDS transmission lines. These back terminations act to absorb reflections from impedance discontinuities on the output traces, improving the signal integrity of the output traces and adding flexibility to how the output traces can be routed. For example, interlayer vias can be used to route the [ADV3002](#) TMDS outputs on multiple layers of the PCB without severely degrading the quality of the output signal.

Auxiliary Control Signals

There are four single-ended control signals associated with each source or sink in an HDMI/DVI application. These are hot plug detect (HPD), consumer electronics control (CEC), and two display data channel (DDC) lines. The two signals on the DDC bus are SDA and SCL (serial data and serial clock, respectively). The DDC and CEC signals are buffered and switched through the [ADV3002](#), and the HPD signal is pulsed low by the [ADV3002](#). These signals do not need to be routed with the same strict considerations as the high speed TMDS signals.

In general, it is sufficient to route each auxiliary signal as a single-ended trace. These signals are not sensitive to impedance discontinuities, do not require a reference plane, and can be routed on multiple layers of the PCB. However, it is best to follow strict layout practices whenever possible to prevent the PCB design from affecting the overall application. The specific routing of the HPD, CEC, and DDC lines depends upon the application in which the [ADV3002](#) is being used.

For example, the maximum speed of signals present on the auxiliary lines are 100 kHz I²C data on the DDC lines, therefore, any layout that enables 100 kHz I²C to be passed over the DDC bus should suffice. The HDMI 1.3a compliance test specification, however, places a strict 50 pF limit on the amount of capacitance that can be measured on either SDA or SCL at the HDMI input connector. The 50 pF limit includes the HDMI connector, the PCB, and whatever capacitance is seen at the input of the ADV3002, or an equivalent receiver. There is a similar limit of 150 pF of input capacitance for the CEC line. The benefit of the ADV3002 is that it buffers these lines, isolating the output capacitance so that only the capacitance at the input side contributes to the specified limit.

The parasitic capacitance of traces on a PCB increases with trace length. To help ensure that a design satisfies the HDMI specification, make the length of the CEC and DDC lines on the PCB as short as possible. Additionally, if there is a reference plane in the layer adjacent to the auxiliary traces in the PCB stackup, relieving or clearing out this reference plane immediately under the auxiliary traces significantly decreases the amount of parasitic trace capacitance. An example of the board stackup is shown in Figure 40.

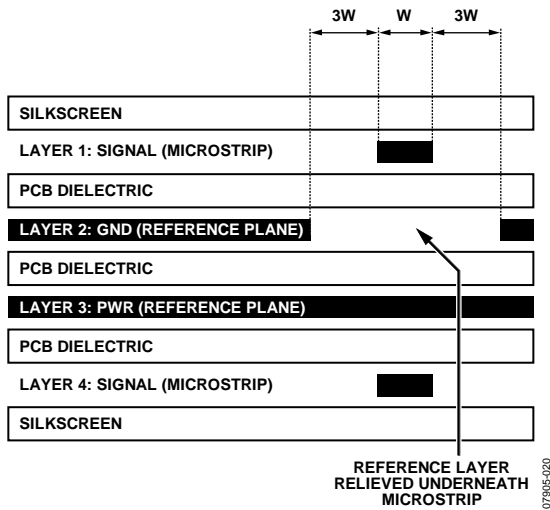

Figure 40. Example Board Stackup for Auxiliary Control Signals

HPD is a dc signal presented by a sink to a source to indicate that the source EDID is available for reading. The trace routing of this signal is not critical, but it should be routed as directly as possible.

When the ADV3002 is powered up, the DDC/CEC inputs of the selected channel are actively buffered and routed to the outputs, and the unselected auxiliary inputs are high impedance. When the ADV3002 is powered off, all DDC/CEC inputs are placed in a high impedance state. This prevents contention on the DDC bus, enabling a design to include an EDID in front of the ADV3002.

Power Supplies

The ADV3002 has two separate power supplies. The supply/ground pairs are

- AVCC/AVEE
- AMUXVCC/AVEE

The AVCC/AVEE (3.3 V) supply powers the core of the ADV3002. The AMUXVCC/AVEE supply (5 V) powers the auxiliary multiplexer and EDID replication core.

Power Supply Bypassing

The ADV3002 requires minimal supply bypassing. Generally, place bypass capacitors near the power pins and connect them directly to the relevant supplies (without long intervening traces). For example, to improve the parasitic inductance of the power supply decoupling capacitors, minimize the trace length between capacitor landing pads and the vias. The capacitors should via down directly to the supply planes and should be placed within a few centimeters of the ADV3002.

Unused DDC/CEC Buffers

If the DDC and the CEC buffers are not used, the ADV3002 does not require a 5 V supply for AMUXVCC. For operation without the buffers, tie AMUXVCC to AVCC (nominally 3.3 V).

OUTLINE DIMENSIONS

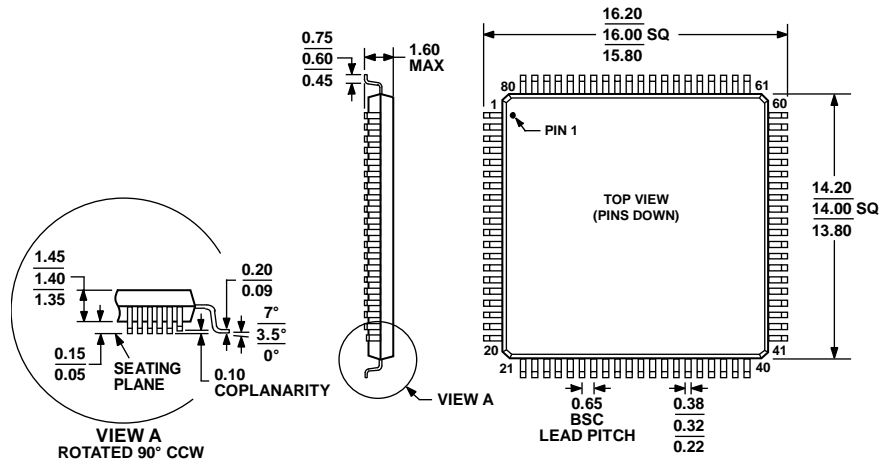

COMPLIANT TO JEDEC STANDARDS MS-026-BEC

Figure 41. 80-Lead Low Profile Quad Flat Package [LQFP] (ST-80-2)

Dimensions shown in millimeters

051706-A

ORDERING GUIDE

Model ¹	Temperature Range	Package Description	Package Option	Ordering Quantity
ADV3002BSTZ	0°C to +85°C	80-Lead Low Profile Quad Flat Package [LQFP]	ST-80-2	1000
ADV3002BSTZ-RL	0°C to +85°C	80-Lead Low Profile Quad Flat Package [LQFP], 13 Tape and Reel	ST-80-2	
ADV3002-EVALZ		Evaluation Board		

¹ Z = RoHS Compliant Part.

NOTES

I²C refers to a communications protocol originally developed by Philips Semiconductors (now NXP Semiconductors).

Looking for pricing, stock, or lifecycle information?

Click below to explore more details on WIN SOURCE:

 [View ADV3002BSTZ on WIN SOURCE](#)

 [Analog Devices Inc. Information](#)

Optimize Your Supply Chain with WIN SOURCE Solutions

-  Global Sourcing Solution
-  Obsolete Management
-  Cost Control Management
-  Shortage Management
-  Alternative Solution
-  Excess Inventory Management