



THE DATASHEET OF STP10N65K3



N-channel 650 V, 0.75 Ω typ., 10 A SuperMESH3™ Power MOSFETs
in D²PAK, TO-220FP, I²PAKFP and TO-220 packages

Datasheet - production data

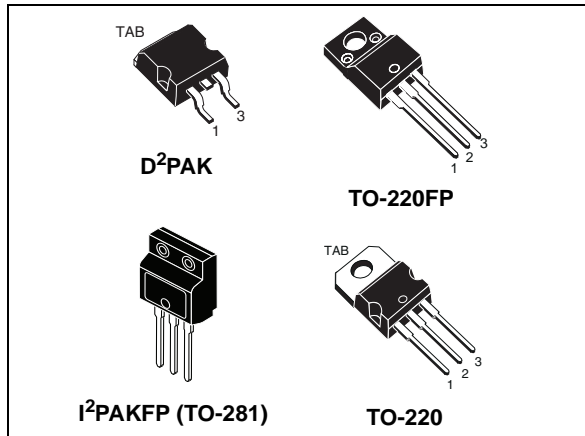
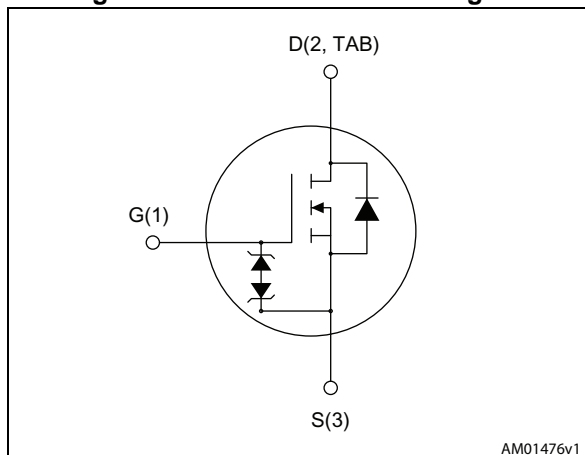

Figure 1. Internal schematic diagram



Features

Order codes	V _{DS}	R _{DS(on)} max	I _D	P _{TOT}
STB10N65K3	650 V	1 Ω	10 A	150 W
STF10N65K3				35 W
STFI10N65K3				
STP10N65K3				150 W

- 100% avalanche tested
- Extremely low on-resistance R_{DS(on)}
- Gate charge minimized
- Very low intrinsic capacitances
- Improved diode reverse recovery characteristics
- Zener-protected

Applications

- Switching applications

Description

These SuperMESH3™ Power MOSFETs are the result of improvements applied to STMicroelectronics' SuperMESH™ technology, combined with a new optimized vertical structure. These devices boast an extremely low on-resistance, superior dynamic performance and high avalanche capability, rendering them suitable for the most demanding applications.

Table 1. Device summary

Order codes	Marking	Package	Packaging
STB10N65K3	10N65K3	D ² PAK	Tape and reel
STF10N65K3		TO-220FP	Tube
STFI10N65K3		I ² PAKFP (TO-281)	
STP10N65K3		TO-220	

Contents

1	Electrical ratings	3
2	Electrical characteristics	4
2.1	Electrical characteristics (curves)	6
3	Test circuits	9
4	Package mechanical data	10
5	Packaging mechanical data	18
6	Revision history	20

1 Electrical ratings

Table 2. Absolute maximum ratings

Symbol	Parameter	Value		Unit
		TO-220FP I ² PAKFP	D ² PAK, TO-220	
V _{DS}	Drain source voltage	650		V
V _{GS}	Gate-source voltage	± 30		V
I _D	Drain current (continuous) at T _C = 25 °C	10		A
I _D	Drain current (continuous) at T _C = 100 °C	6.3		A
I _{DM} ⁽¹⁾	Drain current (pulsed)	40		A
P _{TOT}	Total dissipation at T _C = 25 °C	35	150	W
I _{AR}	Max current during repetitive or single pulse avalanche (pulse width limited by T _{JMAX})	7.2		A
E _{AS}	Single pulse avalanche energy ⁽²⁾	212		mJ
	Derating factor	0.28	1.2	W/°C
dv/dt ⁽³⁾	Peak diode recovery voltage slope	12		V/ns
ESD	Gate-source human body model (R = 1.5 kΩ, C = 100 pF)	2.8		kV
V _{ISO}	Insulation withstand voltage (RMS) from all three leads to external heat sink (t=1 s; T _C =25 °C)	2500		V
T _j	Operating junction temperature	-55 to 150		°C
T _{stg}	Storage temperature			°C

1. Pulse width limited by safe operating area.
2. Starting T_j = 25 °C, I_D = I_{AR}, V_{DD} = 50 V
3. I_{SD} ≤ 10 A, di/dt = 100 A/μs, V_{Peak} < V_{(BR)DSS}

Table 3. Thermal data

Symbol	Parameter	Value			Unit
		D ² PAK	TO-220FP I ² PAKFP	TO-220	
R _{thj-case}	Thermal resistance junction-case max	0.83	3.57	0.83	°C/W
R _{thj-amb}	Thermal resistance junction-ambient max		62.5		°C/W
R _{thj-pcb}	Thermal resistance junction-pcb max	30			°C/W

2 Electrical characteristics

(T_{case} = 25 °C unless otherwise specified)

Table 4. On /off states

Symbol	Parameter	Test conditions	Min.	Typ.	Max.	Unit
V _{(BR)DSS}	Drain-source breakdown voltage	I _D = 1 mA, V _{GS} = 0	650			V
I _{DSS}	Zero gate voltage drain current (V _{GS} = 0)	V _{DS} = 650 V			1	μA
		V _{DS} = 650 V, T _C = 125 °C			50	μA
I _{GSS}	Gate-body leakage current (V _{DS} = 0)	V _{GS} = ± 20 V			±10	μA
V _{GS(th)}	Gate threshold voltage	V _{DS} = V _{GS} , I _D = 100 μA	3		4.5	V
R _{DS(on)}	Static drain-source on-resistance	V _{GS} = 10 V, I _D = 3.6 A		0.75	1	Ω

Table 5. Dynamic

Symbol	Parameter	Test conditions	Min.	Typ.	Max.	Unit
C _{iss}	Input capacitance	V _{DS} = 25 V, f = 1 MHz, V _{GS} = 0	-	1180	-	pF
C _{oss}	Output capacitance		-	125	-	pF
C _{riss}	Reverse transfer capacitance		-	14	-	pF
C _{oss eq.}	Equivalent output capacitance	V _{DS} = 0 to 520 V, V _{GS} = 0	-	77	-	pF
R _G	Intrinsic gate resistance	f = 1 MHz, I _D = 0	-	3	-	Ω
Q _g	Total gate charge	V _{DD} = 520 V, I _D = 7.2 A, V _{GS} = 10 V (see Figure 18)	-	42	-	nC
Q _{gs}	Gate-source charge		-	7.4	-	nC
Q _{gd}	Gate-drain charge		-	23	-	nC

Table 6. Switching times

Symbol	Parameter	Test conditions	Min.	Typ.	Max	Unit
t _{d(on)}	Turn-on delay time	V _{DD} = 310 V, I _D = 3.5 A, R _G = 4.7 Ω, V _{GS} = 10 V (see Figure 17)	-	14.5	-	ns
t _r	Rise time		-	14	-	ns
t _{d(off)}	Turn-off-delay time		-	44	-	ns
t _f	Fall time		-	35	-	ns

Table 7. Source drain diode

Symbol	Parameter	Test conditions	Min.	Typ.	Max.	Unit
I_{SD}	Source-drain current		-		7.2	A
$I_{SDM}^{(1)}$	Source-drain current (pulsed)				28.8	A
$V_{SD}^{(2)}$	Forward on voltage	$I_{SD} = 7 \text{ A}, V_{GS} = 0$	-		1.5	V
t_{rr}	Reverse recovery time	$I_{SD} = 7 \text{ A}, di/dt = 100 \text{ A}/\mu\text{s}$ $V_{DD} = 60 \text{ V}$ (see Figure 22)	-	320		ns
Q_{rr}	Reverse recovery charge		-	2		μC
I_{RRM}	Reverse recovery current		-	13		A
t_{rr}	Reverse recovery time	$I_{SD} = 7 \text{ A}, di/dt = 100 \text{ A}/\mu\text{s}$ $V_{DD} = 60 \text{ V}, T_j = 150 \text{ }^\circ\text{C}$ (see Figure 22)	-	410		ns
Q_{rr}	Reverse recovery charge		-	2.9		μC
I_{RRM}	Reverse recovery current		-	14		A

1. Pulse width limited by safe operating area.
2. Pulsed: Pulse duration = 300 μs , duty cycle 1.5%

Table 8. Gate-source Zener diode

Symbol	Parameter	Test conditions	Min	Typ.	Max.	Unit
$V_{(BR)GSO}$	Gate-source breakdown voltage	$I_{GS} = \pm 1 \text{ mA}, I_D = 0$	30	-	-	V

The built-in back-to-back Zener diodes have been specifically designed to enhance not only the device's ESD capability, but also to make them capable of safely absorbing any voltage transients that may occasionally be applied from gate to source. In this respect, the Zener voltage is appropriate to achieve efficient and cost-effective protection of device integrity. The integrated Zener diodes thus eliminate the need for external components.

2.1 Electrical characteristics (curves)

Figure 2. Safe operating area for D²PAK and TO-220

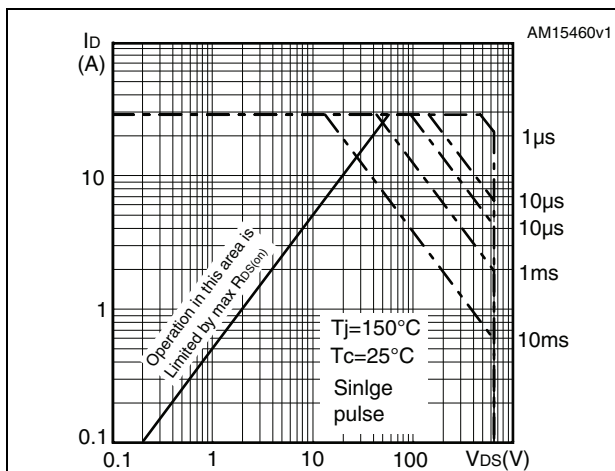

Figure 3. Thermal impedance for D²PAK and TO-220

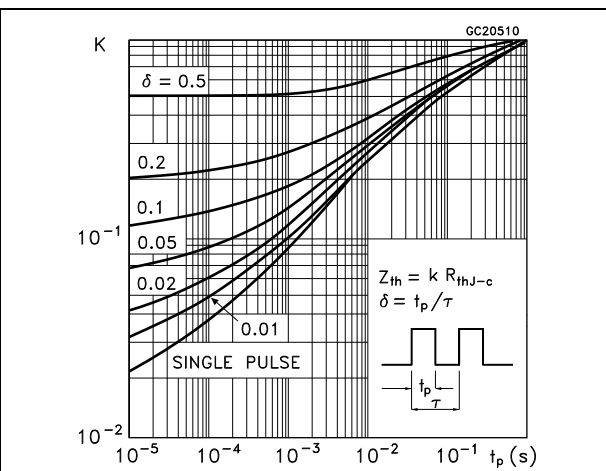

Figure 4. Safe operating area for TO-220FP and I²PAKFP

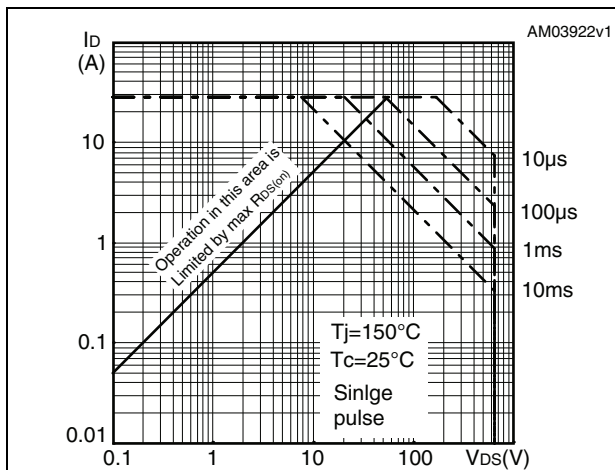

Figure 5. Thermal impedance for TO-220FP and I²PAKFP

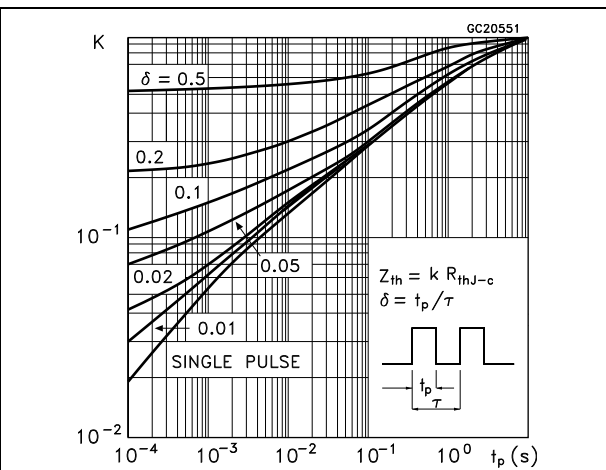

Figure 6. Output characteristics

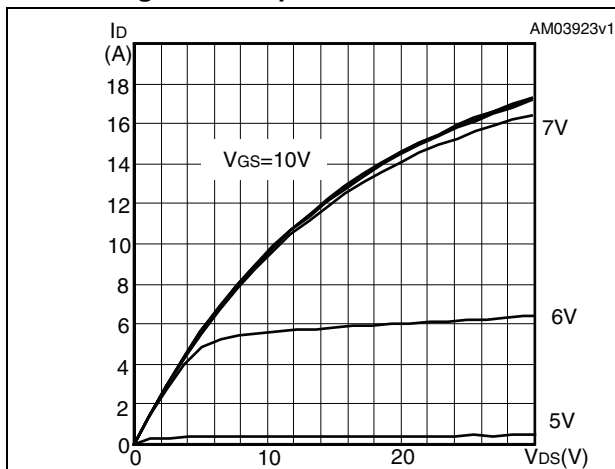

Figure 7. Transfer characteristics

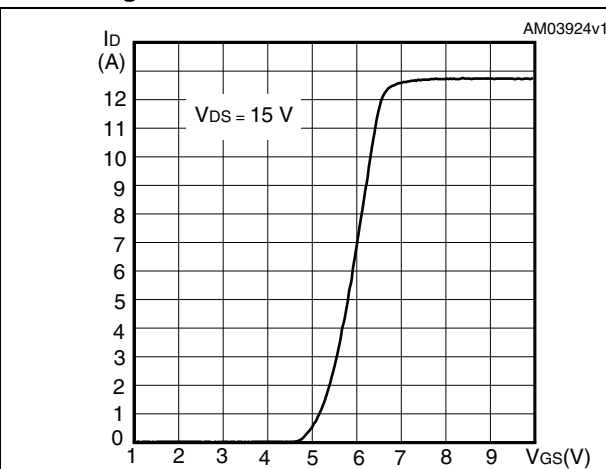

Figure 8. Normalized BV_{DSS} vs temperature

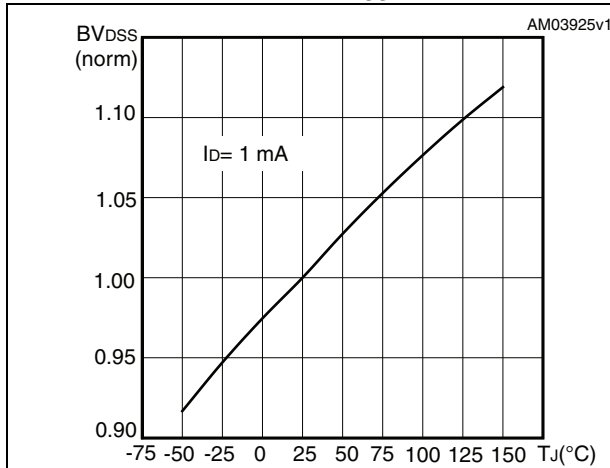

Figure 9. Static drain-source on resistance

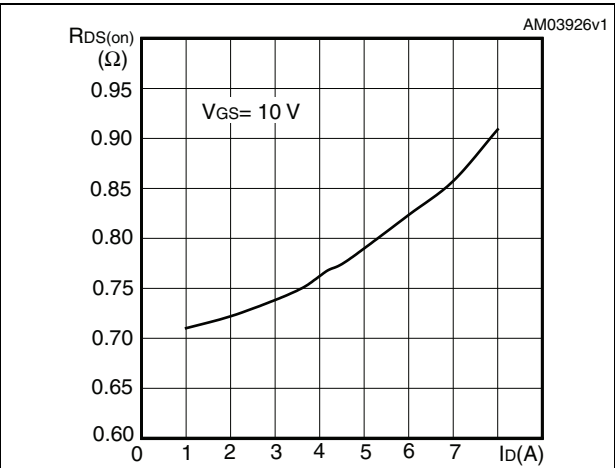

Figure 10. Output capacitance stored energy

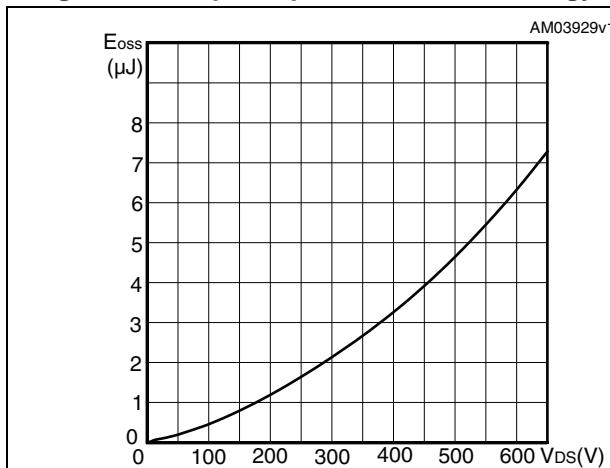

Figure 11. Capacitance variations

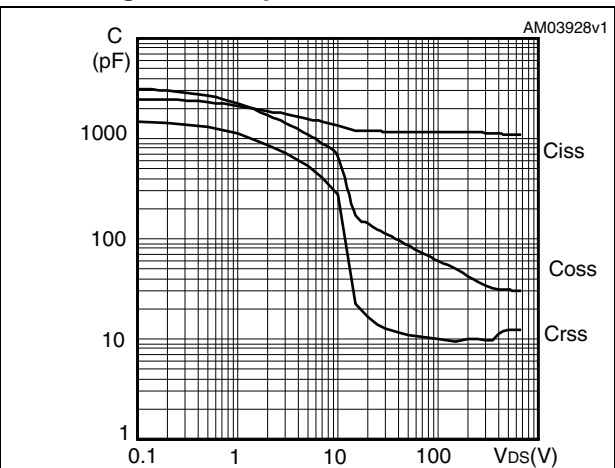

Figure 12. Gate charge vs gate-source voltage

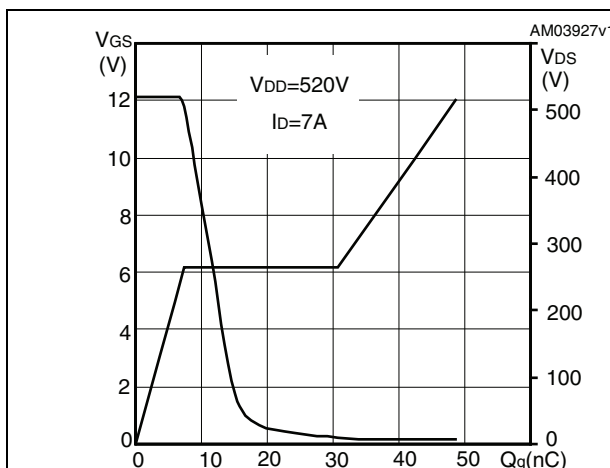

Figure 13. Normalized on-resistance vs temperature

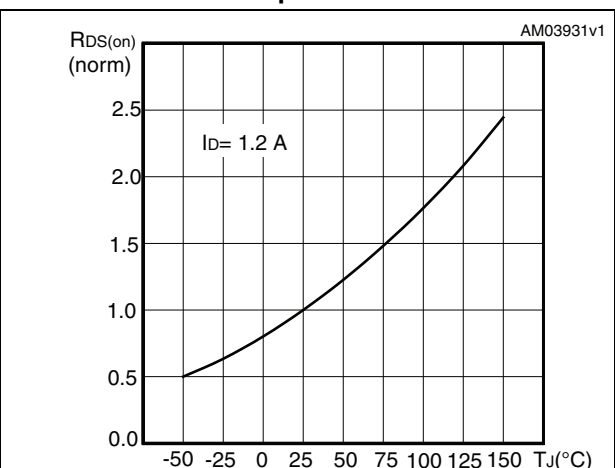

Figure 14. Normalized gate threshold voltage vs temperature

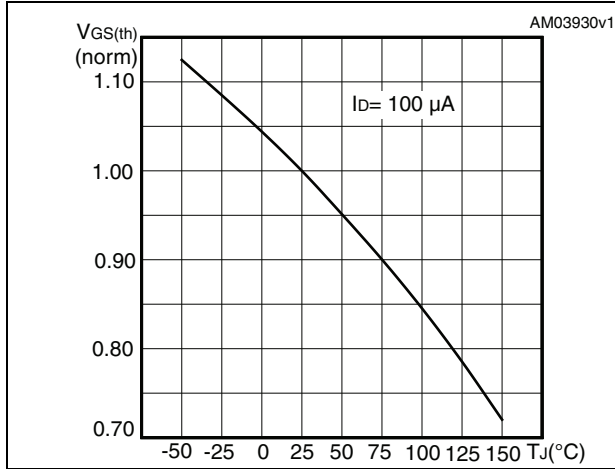

Figure 15. Maximum avalanche energy vs temperature

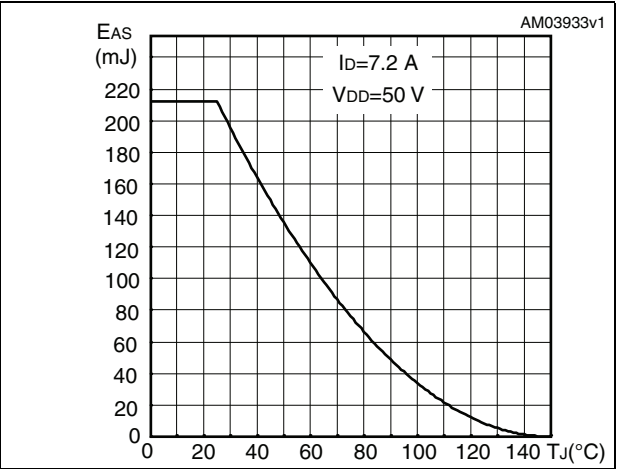
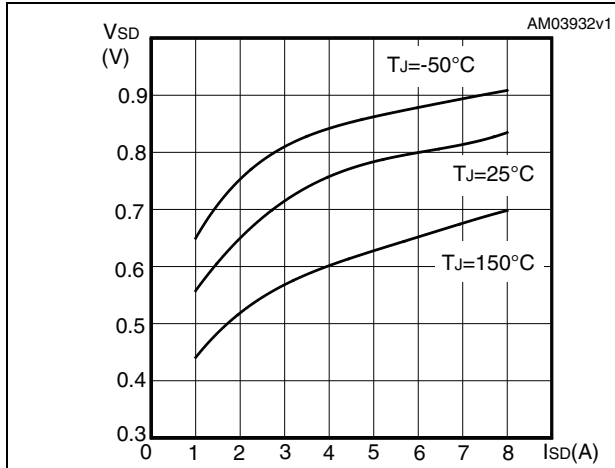

Figure 16. Source-drain diode forward characteristics



4 Package mechanical data

In order to meet environmental requirements, ST offers these devices in different grades of ECOPACK® packages, depending on their level of environmental compliance. ECOPACK® specifications, grade definitions and product status are available at: www.st.com. ECOPACK® is an ST trademark.

Table 9. D²PAK (TO-263) mechanical data

Dim.	mm		
	Min.	Typ.	Max.
A	4.40		4.60
A1	0.03		0.23
b	0.70		0.93
b2	1.14		1.70
c	0.45		0.60
c2	1.23		1.36
D	8.95		9.35
D1	7.50		
E	10		10.40
E1	8.50		
e		2.54	
e1	4.88		5.28
H	15		15.85
J1	2.49		2.69
L	2.29		2.79
L1	1.27		1.40
L2	1.30		1.75
R		0.4	
V2	0°		8°

Figure 23. D²PAK (TO-263) drawing

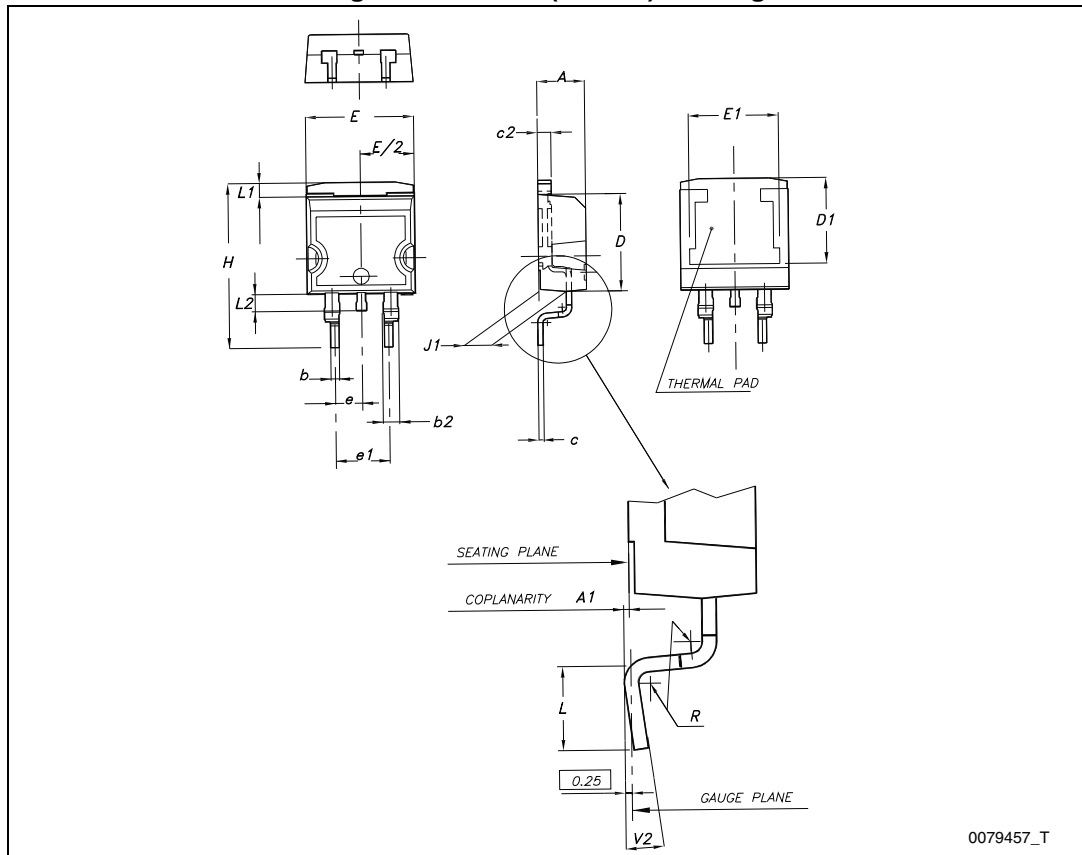
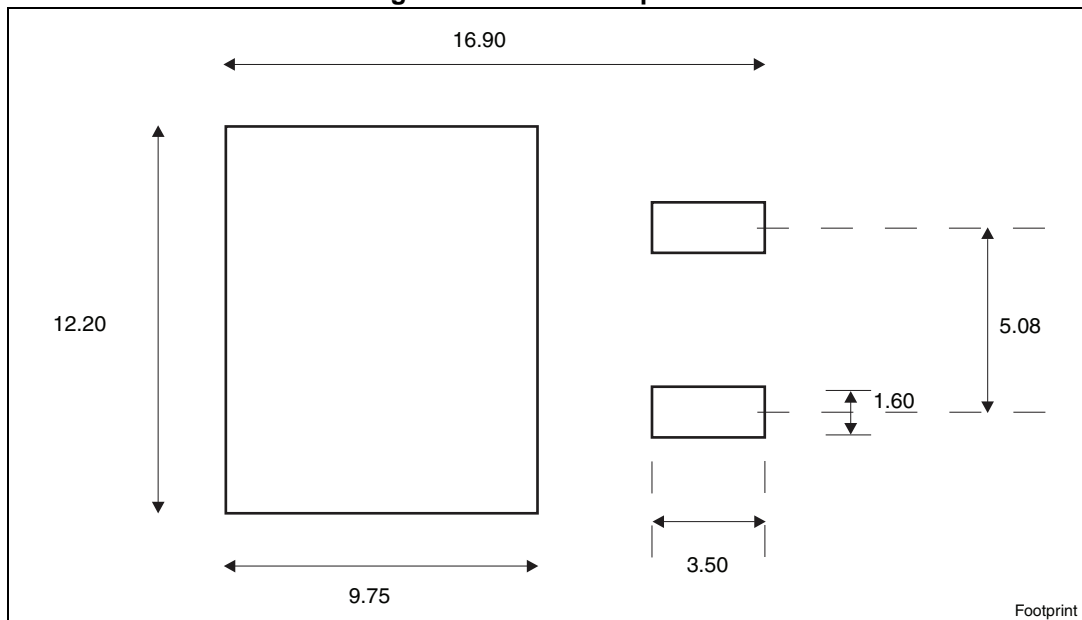

Figure 24. D²PAK footprint^(a)



a. All dimension are in millimeters

Table 10. TO-220FP mechanical data

Dim.	mm		
	Min.	Typ.	Max.
A	4.4		4.6
B	2.5		2.7
D	2.5		2.75
E	0.45		0.7
F	0.75		1
F1	1.15		1.70
F2	1.15		1.70
G	4.95		5.2
G1	2.4		2.7
H	10		10.4
L2		16	
L3	28.6		30.6
L4	9.8		10.6
L5	2.9		3.6
L6	15.9		16.4
L7	9		9.3
Dia	3		3.2

Figure 25. TO-220FP drawing

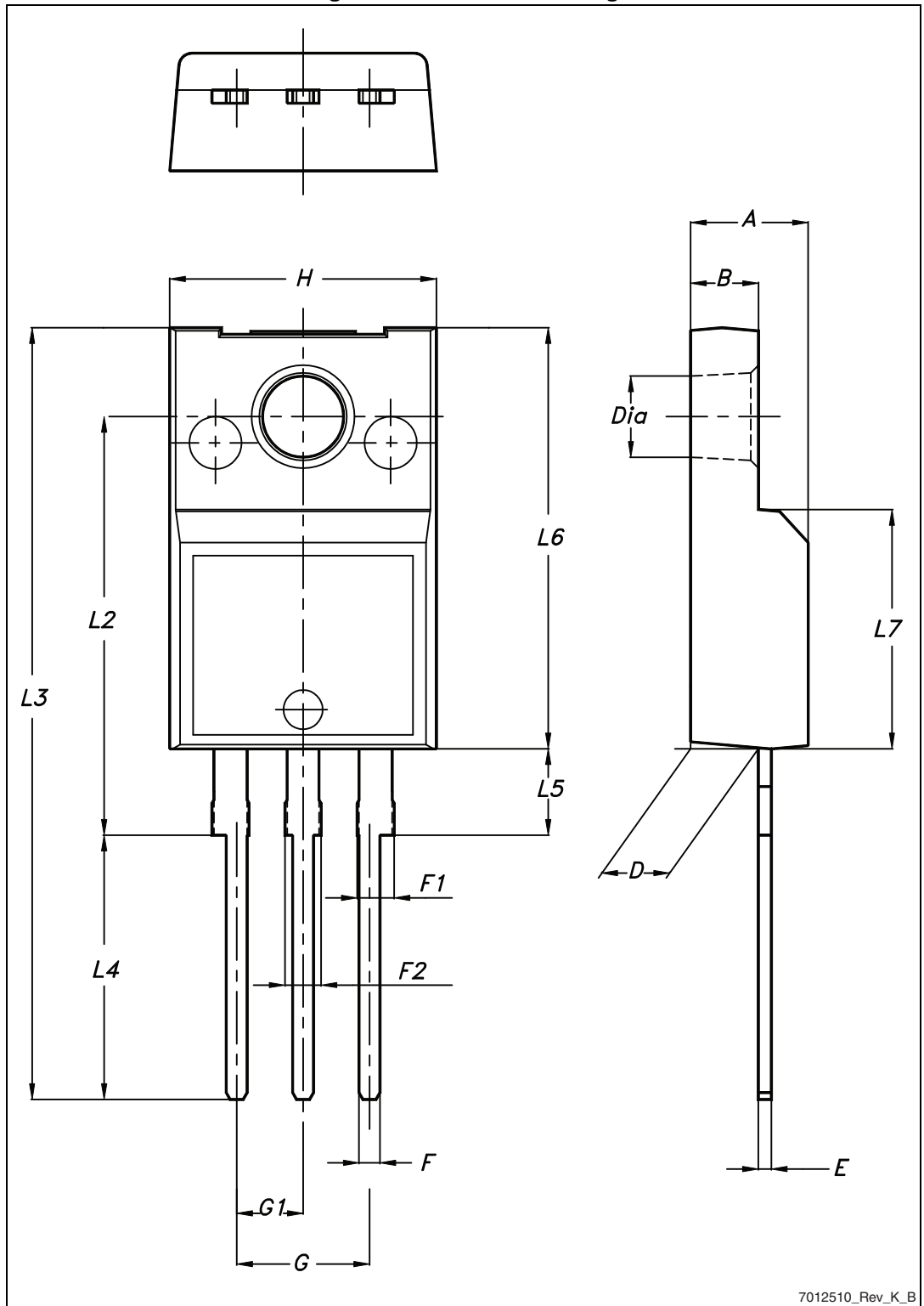

7012510_Rev_K_B

Table 11. I²PAKFP (TO-281) mechanical data

Dim.	mm		
	Min.	Typ.	Max.
A	4.40		4.60
B	2.50		2.70
D	2.50		2.75
D1	0.65		0.85
E	0.45		0.70
F	0.75		1.00
F1			1.20
G	4.95	-	5.20
H	10.00		10.40
L1	21.00		23.00
L2	13.20		14.10
L3	10.55		10.85
L4	2.70		3.20
L5	0.85		1.25
L6	7.30		7.50

Figure 26. I²PAKFP (TO-281) drawing

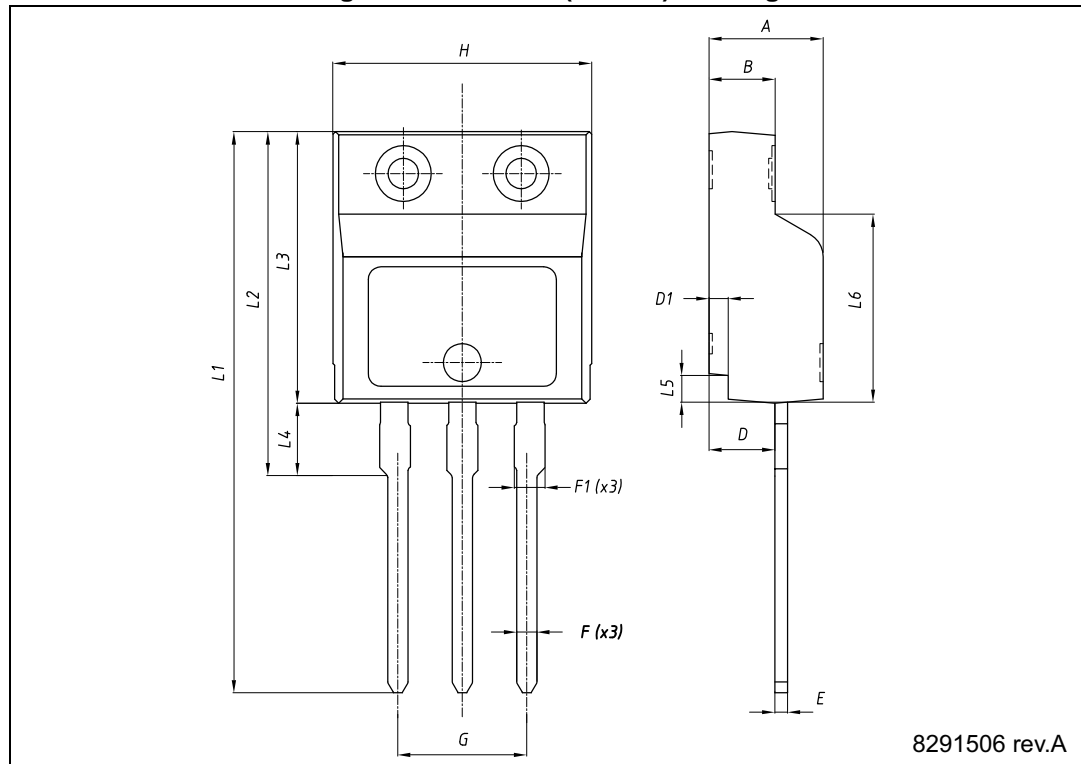

8291506 rev.A

Table 12. TO-220 type A mechanical data

Dim.	mm		
	Min.	Typ.	Max.
A	4.40		4.60
b	0.61		0.88
b1	1.14		1.70
c	0.48		0.70
D	15.25		15.75
D1		1.27	
E	10		10.40
e	2.40		2.70
e1	4.95		5.15
F	1.23		1.32
H1	6.20		6.60
J1	2.40		2.72
L	13		14
L1	3.50		3.93
L20		16.40	
L30		28.90	
ØP	3.75		3.85
Q	2.65		2.95

Figure 27. TO-220 type A drawing

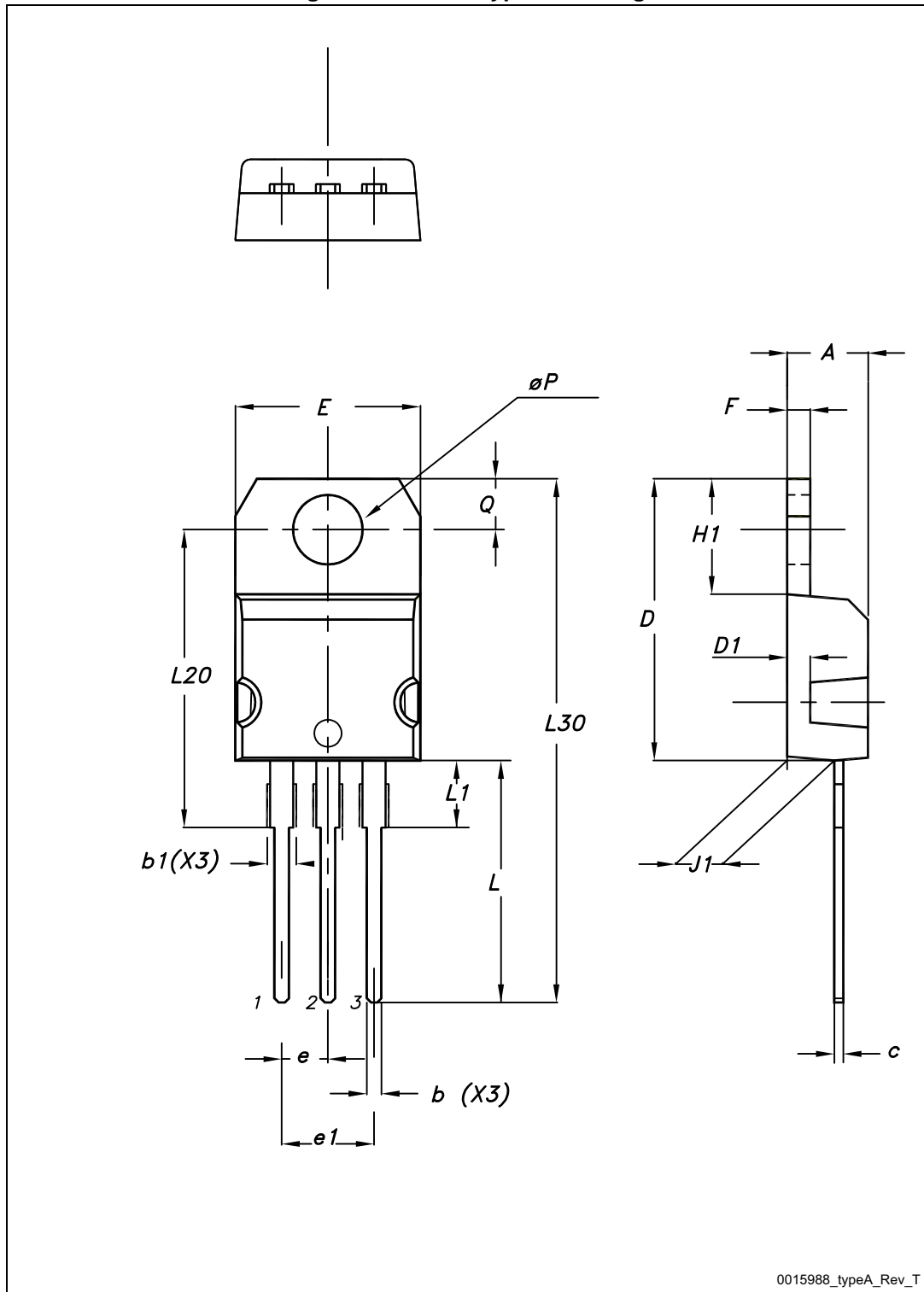

0015988_typeA_Rev_T

5 Packaging mechanical data

Table 13. D²PAK (TO-263) tape and reel mechanical data

Tape			Reel		
Dim.	mm		Dim.	mm	
	Min.	Max.		Min.	Max.
A0	10.5	10.7	A		330
B0	15.7	15.9	B	1.5	
D	1.5	1.6	C	12.8	13.2
D1	1.59	1.61	D	20.2	
E	1.65	1.85	G	24.4	26.4
F	11.4	11.6	N	100	
K0	4.8	5.0	T		30.4
P0	3.9	4.1			
P1	11.9	12.1	Base qty		1000
P2	1.9	2.1	Bulk qty		1000
R	50				
T	0.25	0.35			
W	23.7	24.3			

Figure 28. Tape

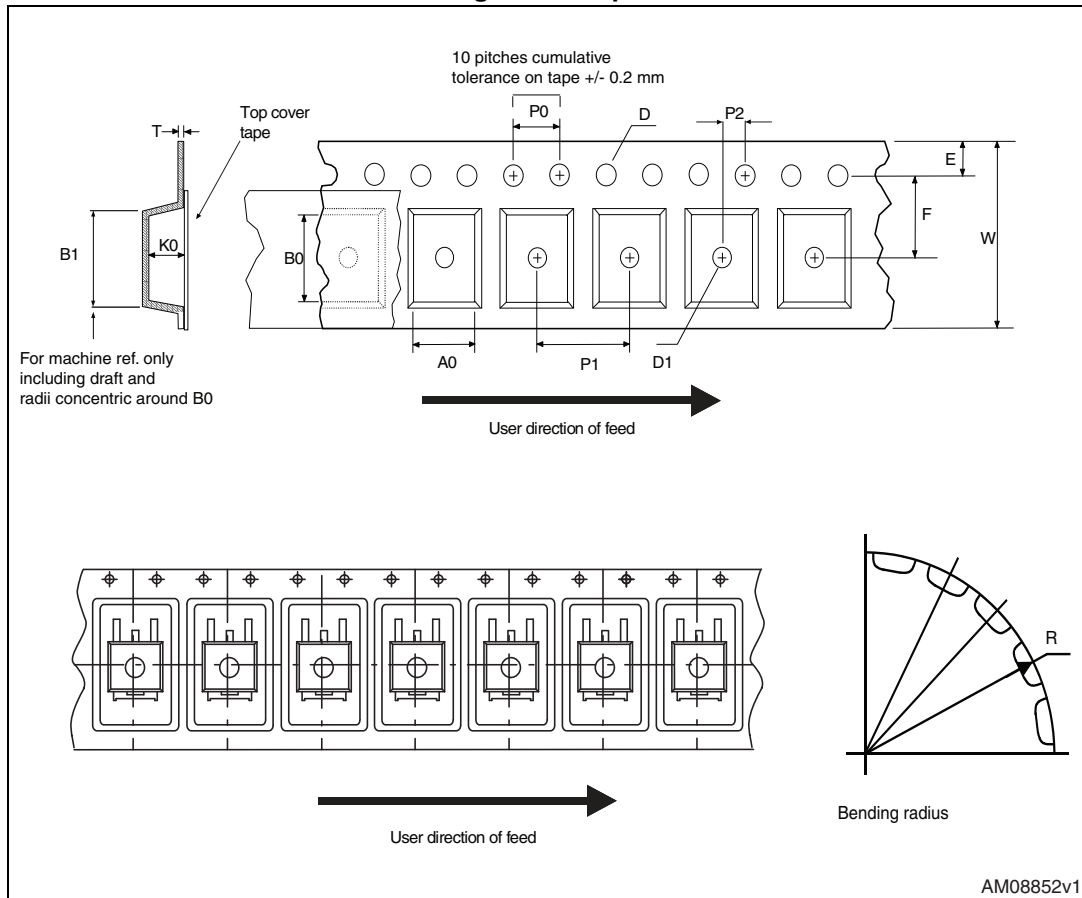
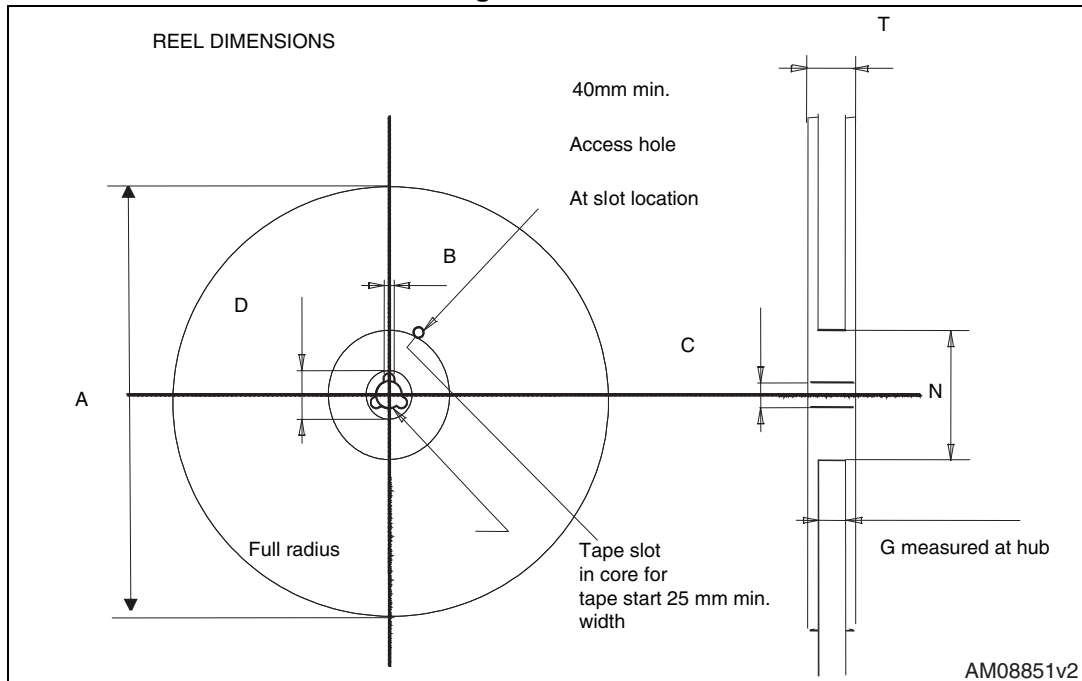

Figure 29. Reel



6 Revision history

Table 14. Document revision history

Date	Revision	Changes
30-Jun-2009	1	First release
14-Nov-2011	2	Updated mechanical data and Section 2.1: Electrical characteristics (curves) . Minor text changes.
14-Nov-2012	3	<ul style="list-style-type: none"> – Added: I²PAKFP and TO-220 – Deleted: T_l row – Added: R_{DS(on)} typical value, Figure 2 and 3 – Modified: Figure 2 – Updated: Section 4: Package mechanical data
05-Aug-2013	4	<ul style="list-style-type: none"> – Added: D²PAK package – Added: R_{thj-pcb} in Table 3 – Updated: figure Figure 17, 18, 19 and 20 – Updated: Section 4: Package mechanical data and Section 5: Packaging mechanical data – Minor text changes

Please Read Carefully:

Information in this document is provided solely in connection with ST products. STMicroelectronics NV and its subsidiaries ("ST") reserve the right to make changes, corrections, modifications or improvements, to this document, and the products and services described herein at any time, without notice.

All ST products are sold pursuant to ST's terms and conditions of sale.

Purchasers are solely responsible for the choice, selection and use of the ST products and services described herein, and ST assumes no liability whatsoever relating to the choice, selection or use of the ST products and services described herein.

No license, express or implied, by estoppel or otherwise, to any intellectual property rights is granted under this document. If any part of this document refers to any third party products or services it shall not be deemed a license grant by ST for the use of such third party products or services, or any intellectual property contained therein or considered as a warranty covering the use in any manner whatsoever of such third party products or services or any intellectual property contained therein.

UNLESS OTHERWISE SET FORTH IN ST'S TERMS AND CONDITIONS OF SALE ST DISCLAIMS ANY EXPRESS OR IMPLIED WARRANTY WITH RESPECT TO THE USE AND/OR SALE OF ST PRODUCTS INCLUDING WITHOUT LIMITATION IMPLIED WARRANTIES OF MERCHANTABILITY, FITNESS FOR A PARTICULAR PURPOSE (AND THEIR EQUIVALENTS UNDER THE LAWS OF ANY JURISDICTION), OR INFRINGEMENT OF ANY PATENT, COPYRIGHT OR OTHER INTELLECTUAL PROPERTY RIGHT.

ST PRODUCTS ARE NOT AUTHORIZED FOR USE IN WEAPONS. NOR ARE ST PRODUCTS DESIGNED OR AUTHORIZED FOR USE IN: (A) SAFETY CRITICAL APPLICATIONS SUCH AS LIFE SUPPORTING, ACTIVE IMPLANTED DEVICES OR SYSTEMS WITH PRODUCT FUNCTIONAL SAFETY REQUIREMENTS; (B) AERONAUTIC APPLICATIONS; (C) AUTOMOTIVE APPLICATIONS OR ENVIRONMENTS, AND/OR (D) AEROSPACE APPLICATIONS OR ENVIRONMENTS. WHERE ST PRODUCTS ARE NOT DESIGNED FOR SUCH USE, THE PURCHASER SHALL USE PRODUCTS AT PURCHASER'S SOLE RISK, EVEN IF ST HAS BEEN INFORMED IN WRITING OF SUCH USAGE, UNLESS A PRODUCT IS EXPRESSLY DESIGNATED BY ST AS BEING INTENDED FOR "AUTOMOTIVE, AUTOMOTIVE SAFETY OR MEDICAL" INDUSTRY DOMAINS ACCORDING TO ST PRODUCT DESIGN SPECIFICATIONS. PRODUCTS FORMALLY ESCC, QML OR JAN QUALIFIED ARE DEEMED SUITABLE FOR USE IN AEROSPACE BY THE CORRESPONDING GOVERNMENTAL AGENCY.

Resale of ST products with provisions different from the statements and/or technical features set forth in this document shall immediately void any warranty granted by ST for the ST product or service described herein and shall not create or extend in any manner whatsoever, any liability of ST.

ST and the ST logo are trademarks or registered trademarks of ST in various countries.

Information in this document supersedes and replaces all information previously supplied.

The ST logo is a registered trademark of STMicroelectronics. All other names are the property of their respective owners.

© 2013 STMicroelectronics - All rights reserved

STMicroelectronics group of companies

Australia - Belgium - Brazil - Canada - China - Czech Republic - Finland - France - Germany - Hong Kong - India - Israel - Italy - Japan - Malaysia - Malta - Morocco - Philippines - Singapore - Spain - Sweden - Switzerland - United Kingdom - United States of America

www.st.com



Looking for pricing, stock, or lifecycle information?

Click below to explore more details on WIN SOURCE:

- ⊖ [View STP10N65K3 on WIN SOURCE](#)
- ⊖ [STMicroelectronics Information](#)

Optimize Your Supply Chain with WIN SOURCE Solutions

- ✓ Global Sourcing Solution
- ✓ Obsolete Management
- ✓ Cost Control Management
- ✓ Shortage Management
- ✓ Alternative Solution
- ✓ Excess Inventory Management