



**THE DATASHEET OF
ADUM2250ARWZ-RL**



FEATURES

- Bidirectional I²C communication**
- Open-drain interfaces**
- Suitable for hot swap applications**
- 30 mA current sink capability**
- 1000 kHz operation**
- 3.0 V to 5.5 V supply/logic levels**
- 16-lead SOIC wide body package version (RW-16)**
- 16-lead SOIC wide body enhanced creepage version (RI-16-2)**
- High temperature operation: 105°C**
- Safety and regulatory approvals**
 - UL recognition: 5000 V rms for 1 minute per UL 1577
 - CSA Component Acceptance Notice 5A (RI-16-2 package)
 - IEC 60601-1: 250 V rms (reinforced)
 - IEC 60950-1: 400 V rms (reinforced)
 - VDE certificate of conformity
 - DIN V VDE V 0884-10 (VDE V 0884-10):2006-12
 - V_{IORM} = 849 V peak
- Qualified for automotive applications**

APPLICATIONS

- Isolated I²C, SMBus, or PMBus interfaces**
- Multilevel I²C interfaces**
- Power supplies**
- Networking**
- Power over Ethernet**

GENERAL DESCRIPTION

The ADuM2250/ADuM2251¹ are hot swappable digital isolators with nonlatching, bidirectional communication channels that are compatible with I²C interfaces. This eliminates the need for splitting I²C signals into separate transmit and receive signals for use with standalone optocouplers.

The ADuM2250 provides two bidirectional channels, supporting a complete isolated I²C interface. The ADuM2251 provides one bidirectional channel and one unidirectional channel for those applications where a bidirectional clock is not required.

The ADuM2250/ADuM2251 contain hot swap circuitry to prevent data glitches when an unpowered card is inserted onto an active bus.

These isolators are based on *iCoupler*[®] chip scale transformer technology from Analog Devices, Inc. *iCoupler* is a magnetic isolation technology with performance, size, power consumption, and functional advantages compared to optocouplers. The ADuM2250/ADuM2251 integrate *iCoupler* channels with semiconductor circuitry to enable a complete, isolated I²C interface in a small form factor package.

FUNCTIONAL BLOCK DIAGRAMS

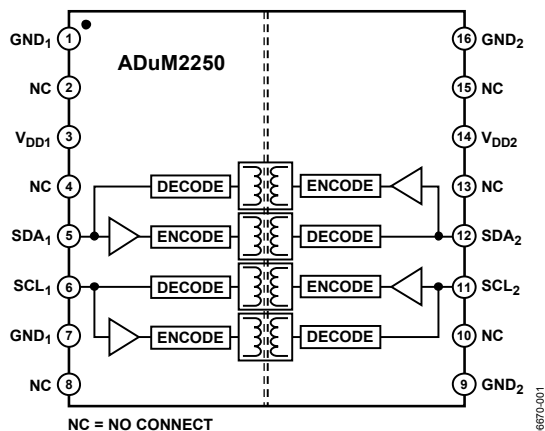

Figure 1. ADuM2250 Functional Block Diagram

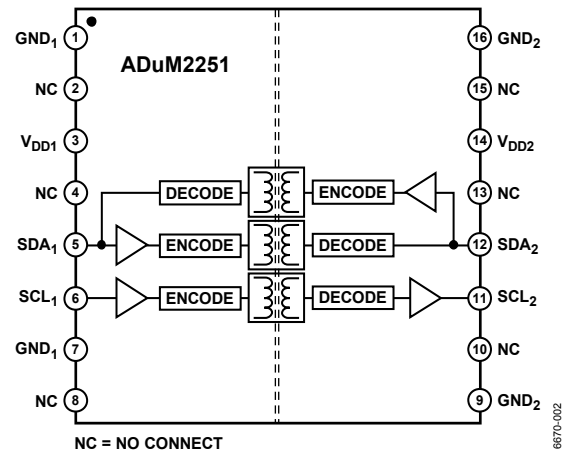

Figure 2. ADuM2251 Functional Block Diagram

¹ Protected by U.S. Patents 5,952,849; 6,873,065; and 7,075,329; other patents pending.

Rev. D

Information furnished by Analog Devices is believed to be accurate and reliable. However, no responsibility is assumed by Analog Devices for its use, nor for any infringements of patents or other rights of third parties that may result from its use. Specifications subject to change without notice. No license is granted by implication or otherwise under any patent or patent rights of Analog Devices. Trademarks and registered trademarks are the property of their respective owners.

Document Feedback

TABLE OF CONTENTS

Features	1	Absolute Maximum Ratings	7
Applications.....	1	ESD Caution.....	7
General Description	1	Pin Configuration and Function Descriptions.....	8
Functional Block Diagrams.....	1	Test Conditions.....	9
Revision History	2	Applications Information	10
Specifications.....	3	Functional Description.....	10
Electrical Characteristics	3	Startup.....	11
Package Characteristics	5	Capacitive Load at Low Speeds	11
Regulatory Information.....	5	Magnetic Field Immunity.....	12
Insulation and Safety Related Specifications	5	Outline Dimensions	13
DIN V VDE V 0884-10 (VDE V 0884-10):2006-12 Insulation		Ordering Guide	14
Characteristics.....	6	Automotive Products.....	14
Recommended Operating Conditions	6		

REVISION HISTORY

7/15—Rev. C to Rev. D

Changes to Table 4 and Table 5.....	5
Changes to Ordering Guide	14

4/14—Rev. B to Rev. C

Changes to Features Section.....	1
Added Capacitive Load at Low Speeds Section.....	11
Changes to Ordering Guide	14
Added Automotive Products Section	14

3/13—Rev. A to Rev. B

Created Hyperlink for Safety and Regulatory Approvals	
Entry in Features Section.....	1
Changes to Features Section.....	1
Changes to Table 4.....	5
Changes to DIN V VDE V 0884-10	
(VDE V 0884-10):2006-12 Section and Table 6	6
Reformatted Table 8	7
Changes to Figure 4, Table 9, and Table 10	8
Moved Test Conditions Section.....	9
Changes to Functional Description Section	10
Changes to Captions of Figure 8 and Figure 9.....	11

9/11—Rev. 0 to Rev. A

Added 16-Lead SOIC.....	Universal
Changes to Features Section and Endnote 1.....	1
Changes to Table 4 and Table 5	6
Changes to Endnote 1 in Table 7	7
Changes to Functional Description Section and Figure 7	10
Updated Outline Dimensions.....	13
Changes to Ordering Guide	13

4/07—Revision 0: Initial Version

SPECIFICATIONS

ELECTRICAL CHARACTERISTICS

DC Specifications

All voltages are relative to their respective grounds. All minimum/maximum specifications apply over the entire recommended operating range, unless otherwise noted. All typical specifications are at $T_A = 25^\circ\text{C}$, $V_{DD1} = 5\text{ V}$, and $V_{DD2} = 5\text{ V}$, unless otherwise noted.

Table 1.

Parameter	Symbol	Min	Typ	Max	Unit	Test Conditions/Comments
ADuM2250						
Input Supply Current, Side 1, 5 V	I_{DD1}		2.8	5.0	mA	$V_{DD1} = 5\text{ V}$
Input Supply Current, Side 2, 5 V	I_{DD2}		2.7	5.0	mA	$V_{DD2} = 5\text{ V}$
Input Supply Current, Side 1, 3.3 V	I_{DD1}		1.9	3.0	mA	$V_{DD1} = 3.3\text{ V}$
Input Supply Current, Side 2, 3.3 V	I_{DD2}		1.7	3.0	mA	$V_{DD2} = 3.3\text{ V}$
ADuM2251						
Input Supply Current, Side 1, 5 V	I_{DD1}		2.8	6.0	mA	$V_{DD1} = 5\text{ V}$
Input Supply Current, Side 2, 5 V	I_{DD2}		2.5	4.7	mA	$V_{DD2} = 5\text{ V}$
Input Supply Current, Side 1, 3.3 V	I_{DD1}		1.8	3.0	mA	$V_{DD1} = 3.3\text{ V}$
Input Supply Current, Side 2, 3.3 V	I_{DD2}		1.6	2.8	mA	$V_{DD2} = 3.3\text{ V}$
LEAKAGE CURRENTS	I_{SDA1} , I_{SDA2} , I_{SCL1} , I_{SCL2}		0.01	10	μA	$V_{SDA1} = V_{DD1}$, $V_{SDA2} = V_{DD2}$, $V_{SCL1} = V_{DD1}$, $V_{SCL2} = V_{DD2}$
SIDE 1 LOGIC LEVELS						
Logic Input Threshold ¹	V_{SDA1IL} , V_{SCL1IL}	500		700	mV	
Logic Low Output Voltage	V_{SDA1OL} , V_{SCL1OL}	600		900	mV	$I_{SDA1} = I_{SCL1} = 3.0\text{ mA}$
		600		850	mV	$I_{SDA1} = I_{SCL1} = 0.5\text{ mA}$
Input/Output Logic Low Level Difference ²	ΔV_{SDA1} , ΔV_{SCL1}	50			mV	
SIDE 2 LOGIC LEVELS						
Logic Low Input Voltage	V_{SDA2IL} , V_{SCL2IL}			$0.3 \times V_{DD2}$	V	
Logic High Input Voltage	V_{SDA2IH} , V_{SCL2IH}	$0.7 \times V_{DD2}$			V	
Logic Low Output Voltage	V_{SDA2OL} , V_{SCL2OL}			400	mV	$I_{SDA2} = I_{SCL2} = 30\text{ mA}$

¹ $V_{IL} < 0.5\text{ V}$, $V_{IH} > 0.7\text{ V}$.

² $\Delta V_{S1} = V_{S1OL} - V_{S1IL}$. This is the minimum difference between the output logic low level and the input logic low threshold within a given component. This ensures that there is no possibility of the part latching up the bus to which it is connected.

AC Specifications

All voltages are relative to their respective grounds. All minimum/maximum specifications apply over the entire recommended operating range, unless otherwise noted. All typical specifications are at $T_A = 25^\circ\text{C}$, $V_{DD1} = 5\text{ V}$, and $V_{DD2} = 5\text{ V}$, unless otherwise noted. See Figure 5 for a timing test diagram.

Table 2.

Parameter	Symbol	Min	Typ	Max	Unit	Test Conditions/Comments
MAXIMUM FREQUENCY		1000			kHz	
OUTPUT FALL TIME						
5 V Operation						$4.5\text{ V} \leq V_{DD1}, V_{DD2} \leq 5.5\text{ V}$, $C_{L1} = 40\text{ pF}$, $R_1 = 1.6\text{ k}\Omega$, $C_{L2} = 400\text{ pF}$, $R_2 = 180\text{ }\Omega$
Side 1 Output (0.9 V_{DD1} to 0.9 V)	t_{f1}	13	26	120	ns	
Side 2 Output (0.9 V_{DD2} to 0.1 V_{DD2})	t_{f2}	32	52	120	ns	
3 V Operation						$3.0\text{ V} \leq V_{DD1}, V_{DD2} \leq 3.6\text{ V}$, $C_{L1} = 40\text{ pF}$, $R_1 = 1.0\text{ k}\Omega$, $C_{L2} = 400\text{ pF}$, $R_2 = 120\text{ }\Omega$
Side 1 Output (0.9 V_{DD1} to 0.9 V)	t_{f1}	13	32	120	ns	
Side 2 Output (0.9 V_{DD2} to 0.1 V_{DD2})	t_{f2}	32	61	120	ns	
PROPAGATION DELAY						
5 V Operation						$4.5\text{ V} \leq V_{DD1}, V_{DD2} \leq 5.5\text{ V}$, $C_{L1} = C_{L2} = 0\text{ pF}$, $R_1 = 1.6\text{ k}\Omega$, $R_2 = 180\text{ }\Omega$
Side 1 to Side 2, Rising Edge ¹	t_{PLH12}		95	130	ns	
Side 1 to Side 2, Falling Edge ²	t_{PHL12}		162	275	ns	
Side 2 to Side 1, Rising Edge ³	t_{PLH21}		31	70	ns	
Side 2 to Side 1, Falling Edge ⁴	t_{PHL21}		85	155	ns	
3 V Operation						$3.0\text{ V} \leq V_{DD1}, V_{DD2} \leq 3.6\text{ V}$, $C_{L1} = C_{L2} = 0\text{ pF}$, $R_1 = 1.0\text{ k}\Omega$, $R_2 = 120\text{ }\Omega$
Side 1 to Side 2, Rising Edge ¹	t_{PLH12}		82	125	ns	
Side 1 to Side 2, Falling Edge ²	t_{PHL12}		196	340	ns	
Side 2 to Side 1, Rising Edge ³	t_{PLH21}		32	75	ns	
Side 2 to Side 1, Falling Edge ⁴	t_{PHL21}		110	210	ns	
PULSE WIDTH DISTORTION						
5 V Operation						$4.5\text{ V} \leq V_{DD1}, V_{DD2} \leq 5.5\text{ V}$, $C_{L1} = C_{L2} = 0\text{ pF}$, $R_1 = 1.6\text{ k}\Omega$, $R_2 = 180\text{ }\Omega$
Side 1 to Side 2, $ t_{PLH12} - t_{PHL12} $	PWD_{12}		67	145	ns	
Side 2 to Side 1, $ t_{PLH21} - t_{PHL21} $	PWD_{21}		54	85	ns	
3 V Operation						$3.0\text{ V} \leq V_{DD1}, V_{DD2} \leq 3.6\text{ V}$, $C_{L1} = C_{L2} = 0\text{ pF}$, $R_1 = 1.0\text{ k}\Omega$, $R_2 = 120\text{ }\Omega$
Side 1 to Side 2, $ t_{PLH12} - t_{PHL12} $	PWD_{12}		114	215	ns	
Side 2 to Side 1, $ t_{PLH21} - t_{PHL21} $	PWD_{21}		77	135	ns	
COMMON-MODE TRANSIENT IMMUNITY ⁵	$ CM_H , CM_L $	25	35		kV/ μs	

¹ t_{PLH12} propagation delay is measured from the Side 1 input logic threshold to an output value of 0.7 V_{DD2} .

² t_{PHL12} propagation delay is measured from the Side 1 input logic threshold to an output value of 0.4 V.

³ t_{PLH21} propagation delay is measured from the Side 2 input logic threshold to an output value of 0.7 V_{DD1} .

⁴ t_{PHL21} propagation delay is measured from the Side 2 input logic threshold to an output value of 0.9 V.

⁵ CM_H is the maximum common-mode voltage slew rate that can be sustained while maintaining $V_O > 0.8 V_{DD2}$. CM_L is the maximum common-mode voltage slew rate that can be sustained while maintaining $V_O < 0.8\text{ V}$. The common-mode voltage slew rates apply to both rising and falling common-mode voltage edges. The transient magnitude is the range over which the common mode is slewed.

PACKAGE CHARACTERISTICS

Table 3.

Parameter	Symbol	Min	Typ	Max	Unit	Test Conditions/Comments
Resistance (Input to Output) ¹	R _{I-O}		10 ¹²		Ω	
Capacitance (Input to Output) ¹	C _{I-O}		2.2		pF	f = 1 MHz
Input Capacitance	C _I		4.0		pF	
IC Junction to Ambient Thermal Resistance	θ _{JA}		45		°C/W	Thermocouple located at center of package underside

¹ The device is considered a 2-terminal device; Pin 1 through Pin 8 are shorted together, and Pin 9 through Pin 16 are shorted together.

REGULATORY INFORMATION

The ADuM2250/ADuM2251 are approved by the organizations listed in Table 4.

Table 4.

UL	CSA	CQC	VDE
Recognized Under UL 1577 Component Recognition Program ¹	Approved under CSA Component Acceptance Notice 5A	Approved under CQC11-471543-2012	Certified according to DIN V VDE V 0884-10 (VDE V 0884-10):2006-12 ²
Single Protection, 5000 V rms Isolation Voltage	Basic insulation per CSA 60950-1-07 and IEC 60950-1, 600 V rms (849 V peak) maximum working voltage RW-16 package: reinforced insulation per CSA 60950-1-07 and IEC 60950-1, 380 V rms (537 V peak) maximum working voltage Reinforced insulation per IEC 60601-1, 125 V rms (176 V peak) maximum working voltage RI-16-2 package: reinforced insulation per CSA 60950-1-07 and IEC 60950-1, 400 V rms (565 V peak) maximum working voltage Reinforced insulation per IEC 60601-1, 250 V rms (353 V peak) maximum working voltage	Basic insulation per GB4943.1-2011, 600 V rms (848 V peak) maximum working voltage, tropical climate, altitude ≤ 5000 m RW-16 package: reinforced insulation per GB4943.1-2011, 380 V rms (537 V peak) maximum working voltage, tropical climate, altitude ≤ 5000 m RI-16 package: reinforced insulation per 400 V rms (565 V peak) maximum working voltage, tropical climate, altitude ≤ 5000 m	Reinforced insulation, 849 V peak
File E214100	File 205078	File CQC14001117251	File 2471900-4880-0001

¹ In accordance with UL 1577, each ADuM2250/ADuM2251 is proof tested by applying an insulation test voltage ≥ 6000 V rms for 1 sec (current leakage detection limit = 10 μA).

² In accordance with DIN V VDE V 0884-10 (VDE V 0884-10):2006-12, each ADuM2250/ADuM2251 is proof tested by applying an insulation test voltage ≥ 1590 V peak for 1 sec (partial discharge detection limit = 5 pC). The asterisk (*) marking branded on the component designates DIN V VDE V 0884-10 (VDE V 0884-10):2006-12 approval.

INSULATION AND SAFETY RELATED SPECIFICATIONS

Table 5.

Parameter	Symbol	Value	Unit	Test Conditions/Comments
Rated Dielectric Insulation Voltage		5000	V rms	1-minute duration
Minimum External Air Gap (Clearance)	L(I01)	8.0 min	mm	Distance measured from input terminals to output terminals, shortest distance through air along the PCB mounting plane, as an aid to PC board layout
Minimum External Tracking (Creepage)	L(I02)			Measured from input terminals to output terminals, shortest distance path along body
RW-16 Package		7.7 min	mm	
RI-16-2 Package		8.3 min	mm	
Minimum Internal Distance (Internal Clearance)		0.017 min	mm	Insulation distance through insulation
Tracking Resistance (Comparative Tracking Index)	CTI	>400	V	DIN IEC 112/VDE 0303, Part 1
Isolation Group		II		Material Group (DIN VDE 0110, 1/89, Table 1)

DIN V VDE V 0884-10 (VDE V 0884-10):2006-12 INSULATION CHARACTERISTICS

These isolators are suitable for reinforced isolation only within the safety limit data. Maintenance of the safety data is ensured by protective circuits. The asterisk (*) marking branded on the component designates DIN V VDE V 0884-10 (VDE V 0884-10):2006-12 approval for an 849 V peak working voltage.

Table 6.

Description	Test Conditions/Comments	Symbol	Characteristic	Unit
Installation Classification per DIN VDE 0110 For Rated Mains Voltage ≤ 300 V rms For Rated Mains Voltage ≤ 450 V rms For Rated Mains Voltage ≤ 600 V rms			I to IV I to II I to II	
Climatic Classification			40/105/21	
Pollution Degree per DIN VDE 0110, Table 1			2	
Maximum Working Insulation Voltage		V _{IORM}	849	V peak
Input to Output Test Voltage, Method b1	V _{IORM} × 1.875 = V _{PR} , 100% production test, t _m = 1 sec, partial discharge < 5 pC	V _{PR}	1592	V peak
Input to Output Test Voltage, Method a		V _{PR}		
After Environmental Tests Subgroup 1	V _{IORM} × 1.6 = V _{PR} , t _m = 60 sec, partial discharge < 5 pC		1358	V peak
After Input and/or Safety Tests Subgroup 2 and Subgroup 3	V _{IORM} × 1.2 = V _{PR} , t _m = 60 sec, partial discharge < 5 pC		1018	V peak
Highest Allowable Overvoltage	Transient overvoltage, t _{TR} = 10 sec	V _{TR}	6000	V peak
Safety Limiting Values	Maximum value allowed in the event of a failure (see Figure 3)			
Case Temperature		T _S	150	°C
Supply Current	I _{DD1} + I _{DD2}	I _S	555	mA
Insulation Resistance at T _S	V _{IO} = 500 V	R _S	>10 ⁹	Ω

Thermal Derating Curve

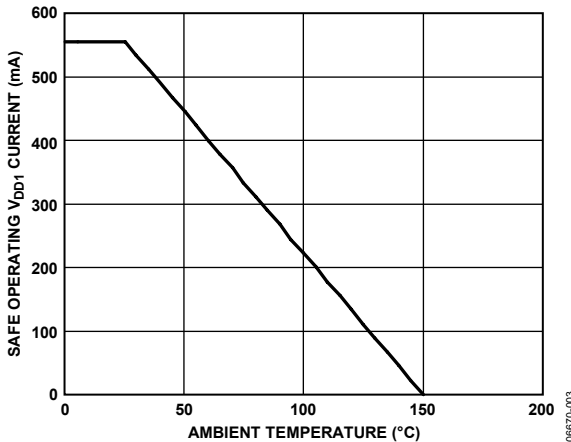

Figure 3. Thermal Derating Curve, Dependence of Safety Limiting Values on Case Temperature, per DIN V VDE V 0884-10

RECOMMENDED OPERATING CONDITIONS

Table 7.

Parameter	Symbol	Min	Max	Unit
Operating Temperature	T _A	-40	+105	°C
Supply Voltages ¹	V _{DD1} , V _{DD2}	3.0	5.5	V
Input/Output Signal Voltage	V _{SDA1} , V _{SCL1} , V _{SDA2} , V _{SCL2}		5.5	V
Capacitive Load				
Side 1	C _{L1}		40	pF
Side 2	C _{L2}		400	pF
Static Output Loading				
Side 1	I _{SDA1} , I _{SCL1}	0.5	3	mA
Side 2	I _{SDA2} , I _{SCL2}	0.5	30	mA

¹ All voltages are relative to their respective grounds.

ABSOLUTE MAXIMUM RATINGS

$T_A = 25^\circ\text{C}$, unless otherwise noted.

Table 8.

Parameter	Rating
Storage Temperature (T_{ST})	-65°C to $+150^\circ\text{C}$
Ambient Operating Temperature (T_A)	-40°C to $+105^\circ\text{C}$
Supply Voltages (V_{DD1} , V_{DD2}) ¹	-0.5 V to $+7.0\text{ V}$
Input/Output Voltage	
Side 1 (V_{SDA1} , V_{SCL1}) ¹	-0.5 V to $V_{DD1} + 0.5\text{ V}$
Side 2 (V_{SDA2} , V_{SCL2}) ¹	-0.5 V to $V_{DD2} + 0.5\text{ V}$
Average Output Current per Pin ²	
Side 1 (I_{O1})	$\pm 18\text{ mA}$
Side 2 (I_{O2})	$\pm 100\text{ mA}$
Common-Mode Transients ³	$-100\text{ kV}/\mu\text{s}$ to $+100\text{ kV}/\mu\text{s}$

¹ All voltages are relative to their respective grounds.

² See Figure 3 for maximum rated current values for various temperatures.

³ Refers to common-mode transients across the insulation barrier. Common-mode transients exceeding the absolute maximum rating may cause latch-up or permanent damage.

Stresses at or above those listed under Absolute Maximum Ratings may cause permanent damage to the product. This is a stress rating only; functional operation of the product at these or any other conditions above those indicated in the operational section of this specification is not implied. Operation beyond the maximum operating conditions for extended periods may affect product reliability.

ESD CAUTION



ESD (electrostatic discharge) sensitive device. Charged devices and circuit boards can discharge without detection. Although this product features patented or proprietary protection circuitry, damage may occur on devices subjected to high energy ESD. Therefore, proper ESD precautions should be taken to avoid performance degradation or loss of functionality.

PIN CONFIGURATION AND FUNCTION DESCRIPTIONS

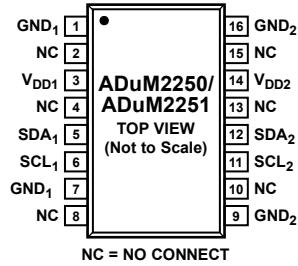

NOTES

- PIN 1 AND PIN 7 ARE INTERNALLY CONNECTED TO EACH OTHER, AND IT IS RECOMMENDED THAT BOTH PINS BE CONNECTED TO A COMMON GROUND.
- PIN 9 AND PIN 16 ARE INTERNALLY CONNECTED TO EACH OTHER, AND IT IS RECOMMENDED THAT BOTH PINS BE CONNECTED TO A COMMON GROUND.

Figure 4. Pin Configuration

Table 9. ADuM2250 Pin Function Descriptions

Pin No.	Mnemonic	Description
1, 7	GND ₁	Ground 1. Ground reference for Isolator Side 1. Pin 1 and Pin 7 are internally connected to each other, and it is recommended that both pins be connected to a common ground.
2, 4, 8, 10, 13, 15	NC	No Connect.
3	V _{DD1}	Supply Voltage, 3.0 V to 5.5 V.
5	SDA ₁	Data Input/Output, Side 1.
6	SCL ₁	Clock Input/Output, Side 1.
9, 16	GND ₂	Ground 2. Isolated ground reference for Isolator Side 2. Pin 9 and Pin 16 are internally connected to each other, and it is recommended that both pins be connected to a common ground.
11	SCL ₂	Clock Input/Output, Side 2.
12	SDA ₂	Data Input/Output, Side 2.
14	V _{DD2}	Supply Voltage, 3.0 V to 5.5 V.

Table 10. ADuM2251 Pin Function Descriptions

Pin No.	Mnemonic	Description
1, 7	GND ₁	Ground 1. Ground reference for Isolator Side 1. Pin 1 and Pin 7 are internally connected to each other, and it is recommended that both pins be connected to a common ground.
2, 4, 8, 10, 13, 15	NC	No Connect.
3	V _{DD1}	Supply Voltage, 3.0 V to 5.5 V.
5	SDA ₁	Data Input/Output, Side 1.
6	SCL ₁	Clock Input, Side 1.
9, 16	GND ₂	Ground 2. Isolated ground reference for Isolator Side 2. Pin 9 and Pin 16 are internally connected to each other, and it is recommended that both pins be connected to a common ground.
11	SCL ₂	Clock Output, Side 2.
12	SDA ₂	Data Input/Output, Side 2.
14	V _{DD2}	Supply Voltage, 3.0 V to 5.5 V.

TEST CONDITIONS

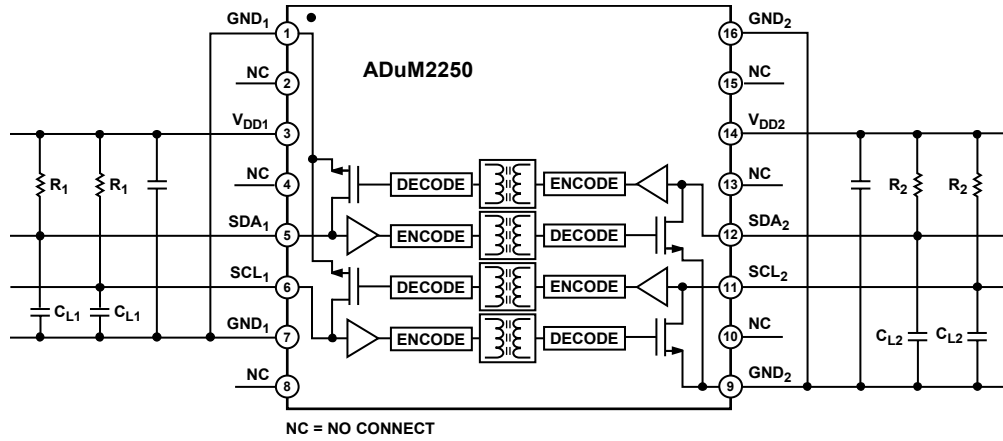

Figure 5. Timing Test Diagram

06870-005

APPLICATIONS INFORMATION

FUNCTIONAL DESCRIPTION

The ADuM2250/ADuM2251 interface on each side to I²C signals. Internally, the bidirectional I²C signals are split into two unidirectional channels communicating in opposite directions via dedicated iCoupler isolation channels. One channel of each pair (the Side 1 input of each input/output pin in Figure 6) implements a special input buffer and output driver that can differentiate between externally generated inputs and its own output signals. It transfers only externally generated input signals to the corresponding Side 2 data or clock pin.

Both the Side 1 and Side 2 I²C pins are designed to interface to an I²C bus operating in the 3.0 V to 5.5 V range. A logic low on either side causes the corresponding input/output pin across the coupler to be pulled low enough to comply with the logic low threshold requirements of other I²C devices on the bus. Bus contention and latch-up are avoided by guaranteeing that the input low threshold at SDA₁ or SCL₁ is at least 50 mV less than the output low signal at the same pin. This prevents an output logic low at Side 1 from being transmitted back to Side 2 and pulling down the I²C bus by latching the state.

Because the Side 2 logic levels/thresholds and drive capabilities comply fully with standard I²C values, multiple ADuM2250/ADuM2251 devices connected to a bus by their Side 2 pins can communicate with each other and with other I²C-compatible devices, as shown in Figure 7. Note the distinction between I²C compatibility and I²C compliance. I²C compatibility refers to situations in which the logic levels or drive capability of a component do not necessarily meet the requirements of the I²C specification but still allow the component to communicate with an I²C-compliant device. I²C compliance refers to situations in which the logic levels and drive capability of a component fully meet the requirements of the I²C specification.

Because the Side 1 pin has a modified output level/input threshold, Side 1 of the ADuM2250/ADuM2251 can communicate only with devices that are fully compliant with the I²C standard. In other words, Side 2 of the ADuM2250/ADuM2251 is I²C-compliant, whereas Side 1 is only I²C-compatible.

The Side 1 input/output pins must not be connected to other I²C buffers that implement a similar scheme of dual input/output threshold detection. This latch-up prevention scheme is implemented in several popular I²C level shifting and bus extension products currently available from Analog Devices and other manufacturers. Care should be taken to review the data sheet of potential I²C bus buffering products to ensure that only one buffer on a bus segment implements a dual threshold scheme.

A bus segment is a portion of the I²C bus that is isolated from other portions of the bus by galvanic isolation, bus extenders, or level shifting buffers. Table 11 shows how multiple ADuM2250/ADuM2251 components can coexist on a bus as long as two Side 1 buffers are not connected to the same bus segment.

Table 11. ADuM2250/ADuM2251 Buffer Compatibility

	Side 1	Side 2
Side 1	No	Yes
Side 2	Yes	Yes

The output logic low levels are independent of the V_{DD1} and V_{DD2} voltages. The input logic low threshold at Side 1 is also independent of V_{DD1}. However, the input logic low threshold at Side 2 is designed to be at 0.3 V_{DD2}, consistent with I²C requirements. The Side 1 and Side 2 input/output pins have open-collector outputs whose high levels are set via pull-up resistors to their respective supply voltages.

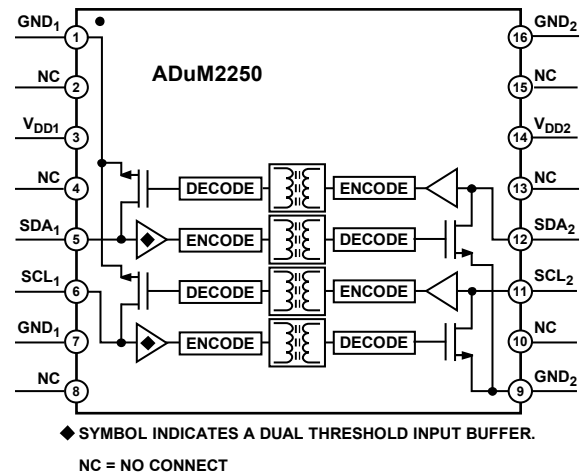

Figure 6. ADuM2250 Block Diagram

Figure 7 shows a typical application circuit, including the pull-up resistors required for both Side 1 and Side 2 buses. Bypass capacitors with values from 0.01 μF to 0.1 μF are required between V_{DD1} and GND₁ and between V_{DD2} and GND₂. The 200 Ω resistor shown in Figure 7 is required for latch-up immunity if the ambient temperature can be between 105°C and 125°C.

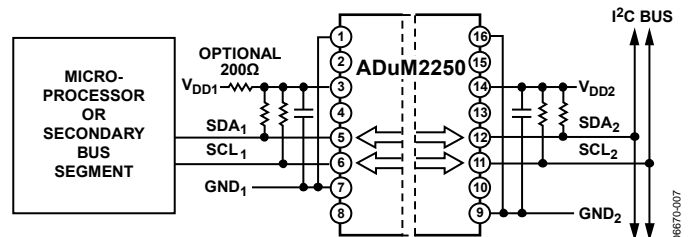

Figure 7. Typical Isolated I²C Interface Using the ADuM2250

STARTUP

Both the V_{DD1} and V_{DD2} supplies have an undervoltage lockout feature that prevents the signal channels from operating unless certain criteria are met. This feature prevents the possibility of input logic low signals pulling down the I²C bus inadvertently during power-up/power-down.

For the signal channels to be enabled, the following criteria must be met:

- Both supplies must be at least 2.5 V.
- At least 40 μ s must elapse after both supplies exceed the internal start-up threshold of 2.0 V.

Until both criteria are met for both supplies, the ADuM2250/ADuM2251 outputs are pulled high, thereby ensuring a startup that avoids any disturbances on the bus. Figure 8 and Figure 9 illustrate the supply conditions for fast and slow input supply slew rates.

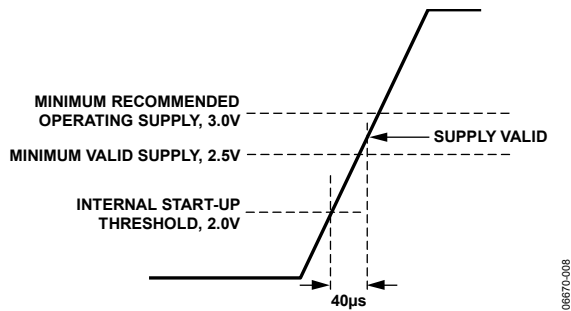

Figure 8. Start-Up Condition, Supply Slew Rate > 12.5 V/ms

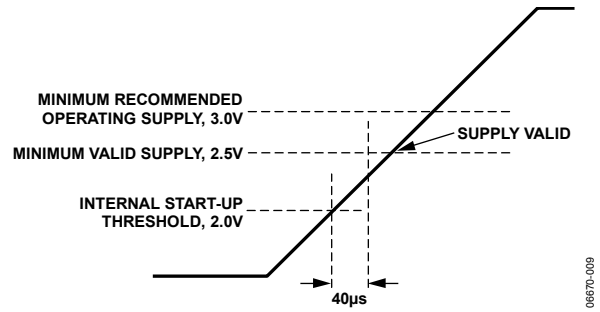

Figure 9. Start-Up Condition, Supply Slew Rate < 12.5 V/ms

CAPACITIVE LOAD AT LOW SPEEDS

The ADuM2250/ADuM2251 are designed for operation at speeds up to 1 Mbps. Due to the limited current available on Side 1 operation at 1 Mbps limits the capacitance that can be driven at the minimum pull-up value to 40 pF.

Most applications operate at 100 kbps in standard mode or 400 kbps in fast mode. At these lower operating speeds, the limitation on the load capacitance can be significantly relaxed. Table 12 shows the maximum capacitance at minimum pull-up values for standard and fast operating modes. If larger values for the pull-up resistor are used, the maximum supported capacitance must be scaled down proportionately so that the rise time does not increase beyond the values required by the standard.

Table 12. Side 1 Maximum Load Conditions

Mode	Maximum Capacitive Load for Side 1					
	V_{DD1}	Data Rate (kbps)	t_r (ns)	t_f (ns)	R_1 (Ω)	C_{L1} (pF)
Standard	5	100	1000	187	1600	484
Fast	5	400	300	172	1600	120
Standard	3.3	100	1000	270	1000	771
Fast	3.3	400	300	235	1000	188

MAGNETIC FIELD IMMUNITY

The ADuM2250/ADuM2251 are extremely immune to external magnetic fields. The limitation on the magnetic field immunity of the ADuM2250/ADuM2251 is set by the condition in which induced voltage in the receiving coil of the transformer is sufficiently large to either falsely set or reset the decoder. The following analysis defines the conditions under which this may occur. The 3 V operating condition of the ADuM2250/ADuM2251 is examined because it represents the most susceptible mode of operation.

The pulses at the transformer output have an amplitude greater than 1.0 V. The decoder has a sensing threshold at approximately 0.5 V, thus establishing a 0.5 V margin in which induced voltages can be tolerated. The voltage induced across the receiving coil is given by

$$V = (-d\beta/dt) \sum \pi r_n^2; n = 1, 2, \dots, N$$

where:

β is the magnetic flux density (gauss).

r_n is the radius of the n^{th} turn in the receiving coil (cm).

N is the number of turns in the receiving coil.

Given the geometry of the receiving coil in the ADuM2250/ADuM2251 and an imposed requirement that the induced voltage be, at most, 50% of the 0.5 V margin at the decoder, a maximum allowable magnetic field is calculated, as shown in Figure 10.

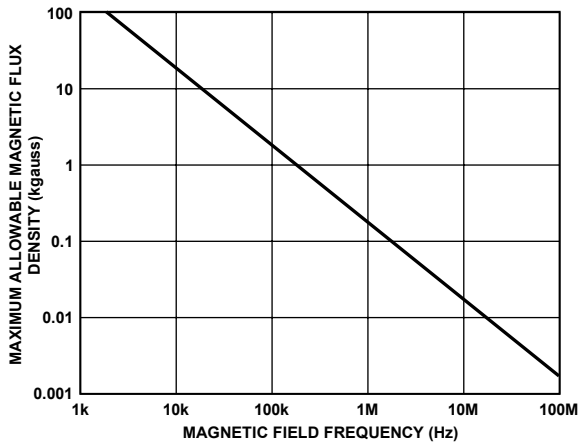

Figure 10. Maximum Allowable External Magnetic Flux Density

For example, at a magnetic field frequency of 1 MHz, the maximum allowable magnetic field of 0.2 kgauss induces a voltage of 0.25 V at the receiving coil. This voltage is approximately 50% of the sensing threshold and does not cause a faulty output transition. Similarly, if such an event occurs during a transmitted pulse (and is of the worst-case polarity), it reduces the received pulse from >1.0 V to 0.75 V—still well above the 0.5 V sensing threshold of the decoder.

The preceding magnetic flux density values correspond to specific current magnitudes at given distances away from the ADuM2250/ADuM2251 transformers. Figure 11 expresses these allowable current magnitudes as a function of frequency for selected distances. As shown in Figure 11, the ADuM2250/ADuM2251 are extremely immune and can be affected only by extremely large currents operated at high frequency very close to the component. For the 1 MHz example, a 0.5 kA current must be placed 5 mm away from the ADuM2250/ADuM2251 to affect the operation of the component.

Note that at combinations of strong magnetic fields and high frequencies, any loops formed by printed circuit board traces can induce error voltages sufficiently large to trigger the thresholds of succeeding circuitry. Exercise care in the layout of such traces to avoid this possibility.

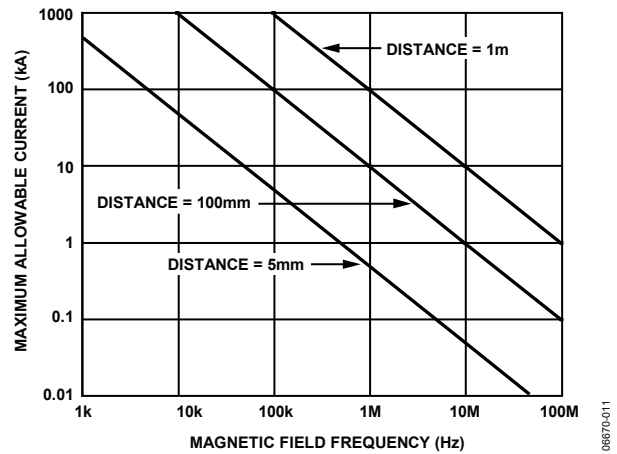
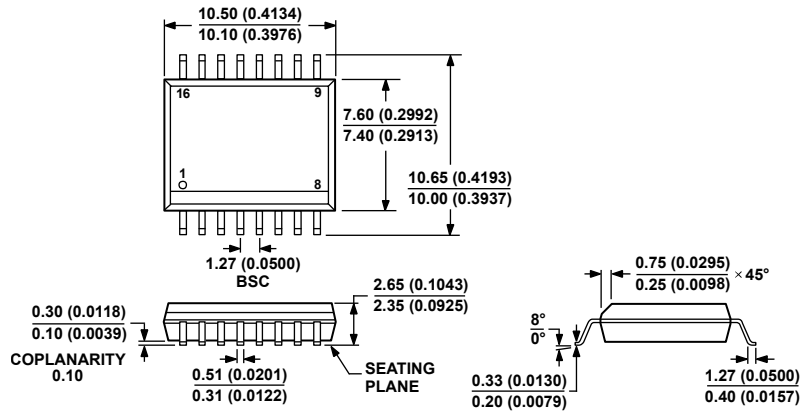

Figure 11. Maximum Allowable Current for Various Current-to-ADuM2250/ADuM2251 Spacings

OUTLINE DIMENSIONS



COMPLIANT TO JEDEC STANDARDS MS-013-AA
 CONTROLLING DIMENSIONS ARE IN MILLIMETERS; INCH DIMENSIONS
 (IN PARENTHESES) ARE ROUNDED-OFF MILLIMETER EQUIVALENTS FOR
 REFERENCE ONLY AND ARE NOT APPROPRIATE FOR USE IN DESIGN.

03-27-2007-B

Figure 12. 16-Lead Standard Small Outline Package [SOIC_W]
 Wide Body
 (RW-16)
 Dimensions shown in millimeters (inches)

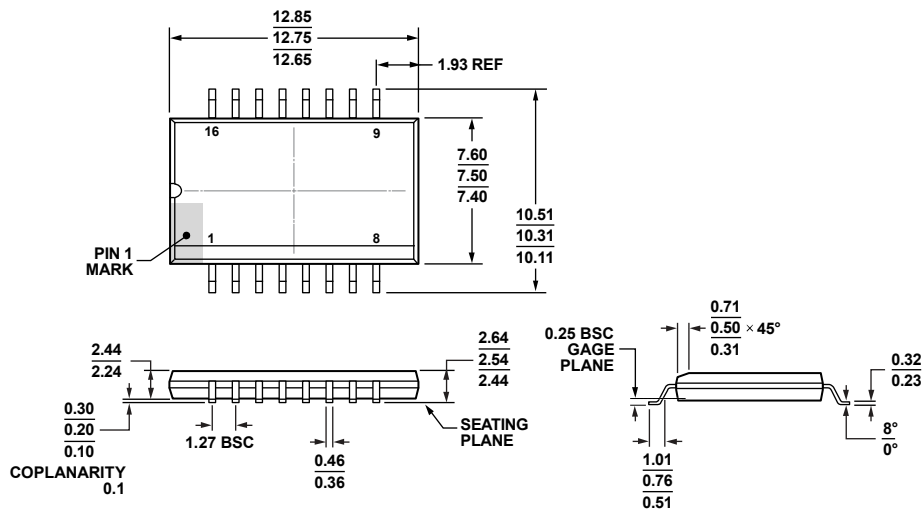

COMPLIANT TO JEDEC STANDARDS MS-013-AC

Figure 13. 16-Lead Standard Small Outline Package, with Increased Creepage [SOIC_IC]
 Wide Body
 (RI-16-2)
 Dimensions shown in millimeters

11-15-2011-A

ORDERING GUIDE

Model ^{1, 2}	Number of Inputs, V _{DD1} Side	Number of Inputs, V _{DD2} Side	Maximum Data Rate (Mbps)	Temperature Range	Package Description	Package Option
ADuM2250ARWZ	2	2	1	-40°C to +105°C	16-Lead SOIC_W	RW-16
ADuM2250ARWZ-RL	2	2	1	-40°C to +105°C	16-Lead SOIC_W, 13" Tape and Reel	RW-16
ADuM2250WARWZ	2	2	1	-40°C to +125°C	16-Lead SOIC_W	RW-16
ADuM2250WARWZ-RL	2	2	1	-40°C to +125°C	16-Lead SOIC_W, 13" Tape and Reel	RW-16
ADuM2250ARIZ	2	2	1	-40°C to +105°C	16-Lead SOIC_IC	RI-16-2
ADuM2250ARIZ-RL	2	2	1	-40°C to +105°C	16-Lead SOIC_IC, 13" Tape and Reel	RI-16-2
ADuM2251ARWZ	2	1	1	-40°C to +105°C	16-Lead SOIC_W	RW-16
ADuM2251ARWZ-RL	2	1	1	-40°C to +105°C	16-Lead SOIC_W, 13" Tape and Reel	RW-16
ADuM2251WARWZ	2	1	1	-40°C to +125°C	16-Lead SOIC_W	RW-16
ADuM2251WARWZ-RL	2	1	1	-40°C to +125°C	16-Lead SOIC_W, 13" Tape and Reel	RW-16
ADuM2251ARIZ	2	1	1	-40°C to +105°C	16-Lead SOIC_IC	RI-16-2
ADuM2251ARIZ-RL	2	1	1	-40°C to +105°C	16-Lead SOIC_IC, 13" Tape and Reel	RI-16-2

¹ Z = RoHS Compliant Part.

² W = Qualified for Automotive Applications.

AUTOMOTIVE PRODUCTS

The [ADuM2250W](#) and [ADuM2251W](#) models are available with controlled manufacturing to support the quality and reliability requirements of automotive applications. Note that these automotive model may have specifications that differ from the commercial model; therefore, designers should review the Specifications section of this data sheet carefully. Only the automotive grade products shown are available for use in automotive applications. Contact your local Analog Devices account representative for specific product ordering information and to obtain the specific Automotive Reliability reports for these models.

NOTES

NOTES

I²C refers to a communications protocol originally developed by Philips Semiconductors (now NXP Semiconductors).

©2007–2015 Analog Devices, Inc. All rights reserved. Trademarks and registered trademarks are the property of their respective owners.
D06670-0-7/15(D)



www.analog.com

Looking for pricing, stock, or lifecycle information?

Click below to explore more details on WIN SOURCE:

- ⊖ [View ADUM2250ARWZ-RL on WIN SOURCE](#)
- ⊖ [Analog Devices Inc. Information](#)

Optimize Your Supply Chain with WIN SOURCE Solutions

- ✓ Global Sourcing Solution
- ✓ Obsolete Management
- ✓ Cost Control Management
- ✓ Shortage Management
- ✓ Alternative Solution
- ✓ Excess Inventory Management