

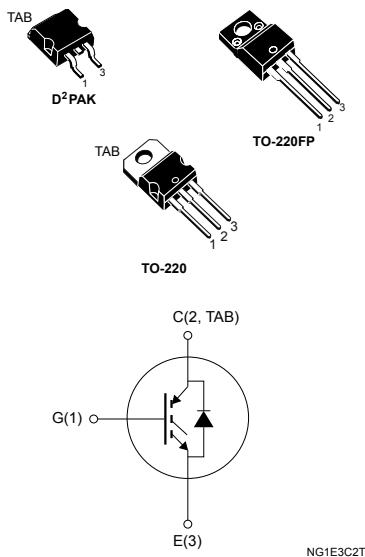

THE DATASHEET OF STGP6NC60HD



N-channel 600 V, 7 A, very fast IGBT



Features

- Low $V_{CE(sat)}$
- Low C_{RES}/C_{IES} ratio (no cross-conduction susceptibility)
- Very soft ultra fast recovery antiparallel diode
- High-frequency operation

Applications

- High-frequency inverters
- SMPS and PFC in both hard switch and resonant topologies
- Motor drivers

Description

Using the latest high-voltage technology based on a patented strip layout, STMicroelectronics has designed an advanced family of IGBTs, the PowerMESH™ IGBTs characterized by an outstanding performance. The “H” suffix identifies a family optimized for high-frequency applications which achieve very high switching performances (reduced t_{fall}) while maintaining a low voltage drop.



Product status link

[STGB6NC60HDT4](#)
[STGF6NC60HD](#)
[STGP6NC60HD](#)

1 Electrical ratings

Table 1. Absolute maximum ratings

Symbol	Parameter	Value		Unit
		D ² PAK, TO-220	TO-220FP	
V _{CES}	Collector-emitter voltage (V _{GE} = 0 V)	600		V
I _C	Continuous collector current at T _C = 25 °C	15	6	A
	Continuous collector current at T _C = 100 °C	7	3	
I _{CM} ⁽¹⁾	Collector current (pulsed)	21		A
V _{GE}	Gate-emitter voltage	±20		V
I _F	Diode RMS forward current at T _C = 25 °C	10		A
P _{TOT}	Total power dissipation at T _C = 25 °C	62.5	25	W
V _{ISO}	Insulation withstand voltage (RMS) from all three leads to external heat sink (t = 1 s; T _C = 25 °C)	2.5		kV
T _{STG}	Storage temperature range	-55 to 150		°C
T _J	Operating junction temperature range			°C

1. Pulse width is limited by maximum junction temperature.

Table 2. Thermal data

Symbol	Parameter	Value		Unit
		D ² PAK, TO-220	TO-220FP	
R _{thJC}	Thermal resistance junction-case	2	5	°C/W
R _{thJA}	Thermal resistance junction-ambient	62.5		°C/W

2 Electrical characteristics

$T_C = 25\text{ °C}$ unless otherwise specified

Table 3. Static characteristics

Symbol	Parameter	Test conditions	Min.	Typ.	Max.	Unit
$V_{(BR)CES}$	Collector-emitter breakdown voltage	$V_{GE} = 0\text{ V}, I_C = 1\text{ mA}$	600			V
$V_{CE(sat)}$	Collector-emitter saturation voltage	$V_{GE} = 15\text{ V}, I_C = 3\text{ A}$		1.9	2.5	V
		$V_{GE} = 15\text{ V}, I_C = 3\text{ A}, T_C = 125\text{ °C}$		1.7		
$V_{GE(th)}$	Gate threshold voltage	$V_{CE} = V_{GE}, I_C = 250\text{ }\mu\text{A}$	3.75		5.75	V
I_{CES}	Collector cut-off current	$V_{GE} = 0\text{ V}, V_{CE} = 600\text{ V}$			10	μA
		$V_{GE} = 0\text{ V}, V_{CE} = 600\text{ V}, T_C = 125\text{ °C}^{(1)}$			1	mA
I_{GES}	Gate-emitter leakage current	$V_{GE} = \pm 20\text{ V}, V_{CE} = 0\text{ V}$			± 100	nA

1. Defined by design, not subject to production test

Table 4. Dynamic characteristics

Symbol	Parameter	Test conditions	Min.	Typ.	Max.	Unit
C_{ies}	Input capacitance	$V_{CE} = 25\text{ V}, f = 1\text{ MHz}, V_{GE} = 0\text{ V}$	-	205	-	pF
C_{oes}	Output capacitance		-	32	-	
C_{res}	Reverse transfer capacitance		-	5.5	-	
Q_g	Total gate charge	$V_{CE} = 390\text{ V}, I_C = 3\text{ A}, V_{GE} = 0\text{ to }15\text{ V}$ (see Figure 18. Gate charge test circuit)	-	13.6	-	nC
Q_{ge}	Gate-emitter charge		-	3	-	
Q_{gc}	Gate-collector charge		-	6	-	
I_{CL}	Turn-off SOA minimum current	$V_{clamp} = 390\text{ V}, T_J = 150\text{ °C}, R_G = 10\text{ }\Omega,$ $V_{GE} = 15\text{ V}$	-	19	-	A

Table 5. Switching characteristics (inductive load)

Symbol	Parameter	Test conditions	Min.	Typ.	Max.	Unit
$t_{d(on)}$	Turn-on delay time	$V_{CC} = 390\text{ V}$, $I_C = 3\text{ A}$, $R_G = 10\ \Omega$, $V_{GE} = 15\text{ V}$ (see Figure 17. Test circuit for inductive load switching)	-	12	-	ns
t_r	Current rise time		-	5	-	
$(di/dt)_{on}$	Turn-on current slope		-	612	-	
$t_{d(on)}$	Turn-on delay time	$V_{CC} = 390\text{ V}$, $I_C = 3\text{ A}$, $R_G = 10\ \Omega$, $V_{GE} = 15\text{ V}$, $T_J = 125\text{ }^\circ\text{C}$ (see Figure 17. Test circuit for inductive load switching)	-	13	-	ns
t_r	Current rise time		-	4.3	-	
$(di/dt)_{on}$	Turn-on current slope		-	560	-	
$t_r(V_{off})$	Off voltage rise time	$V_{CC} = 390\text{ V}$, $I_C = 3\text{ A}$, $R_G = 10\ \Omega$, $V_{GE} = 15\text{ V}$ (see Figure 17. Test circuit for inductive load switching)	-	40	-	ns
$t_{d(off)}$	Turn-off delay time		-	76	-	
t_f	Current fall time		-	100	-	
$t_r(V_{off})$	Off voltage rise time	$V_{CC} = 390\text{ V}$, $I_C = 3\text{ A}$, $R_G = 10\ \Omega$, $V_{GE} = 15\text{ V}$, $T_J = 125\text{ }^\circ\text{C}$ (see Figure 17. Test circuit for inductive load switching)	-	60	-	ns
$t_{d(off)}$	Turn-off delay time		-	98	-	
t_f	Current fall time		-	124	-	

Table 6. Switching energy (inductive load)

Symbol	Parameter	Test conditions	Min.	Typ.	Max.	Unit
$E_{on}^{(1)}$	Turn-on switching energy	$V_{CC} = 390\text{ V}$, $I_C = 3\text{ A}$, $R_G = 10\ \Omega$, $V_{GE} = 15\text{ V}$ (see)Figure 17. Test circuit for inductive load switching	-	20	-	μJ
$E_{off}^{(2)}$	Turn-off switching energy		-	68	-	
E_{ts}	Total switching energy		-	88	-	
$E_{on}^{(1)}$	Turn-on switching energy	$V_{CC} = 390\text{ V}$, $I_C = 3\text{ A}$, $R_G = 10\ \Omega$, $V_{GE} = 15\text{ V}$, $T_J = 125\text{ }^\circ\text{C}$ (see)Figure 17. Test circuit for inductive load switching	-	37	-	μJ
$E_{off}^{(2)}$	Turn-off switching energy		-	93	-	
E_{ts}	Total switching energy		-	130	-	

1. Including the reverse recovery of the diode
2. Including the tail of the collector current

Table 7. Collector-emitter diode

Symbol	Parameter	Test conditions	Min.	Typ.	Max.	Unit
V_f	Forward on-voltage	$I_f = 1.5\text{ A}$	-	1.6	2.1	V
		$I_f = 1.5\text{ A}$, $T_J = 125\text{ }^\circ\text{C}$	-	1.3		
t_{rr}	Reverse recovery time	$I_f = 3\text{ A}$, $V_R = 40\text{ V}$, $di/dt = 100\text{ A}/\mu\text{s}$ (see Figure 20. Diode reverse recovery waveform)	-	21		ns
Q_{rr}	Reverse recovery charge		-	14		nC
I_{rrm}	Reverse recovery current		-	1.36		A
t_{rr}	Reverse recovery time	$I_f = 3\text{ A}$, $V_R = 40\text{ V}$, $T_J = 125\text{ }^\circ\text{C}$, $di/dt = 100\text{ A}/\mu\text{s}$ (see Figure 20. Diode reverse recovery waveform)	-	34		ns
Q_{rr}	Reverse recovery charge		-	32		nC
I_{rrm}	Reverse recovery current		-	1.88		A

2.1 Electrical characteristics (curves)
Figure 1. Output characteristics

Figure 2. Transfer characteristics

Figure 3. Transconductance

Figure 4. Collector-emitter on-voltage vs temperature

Figure 5. Gate charge vs gate-source voltage

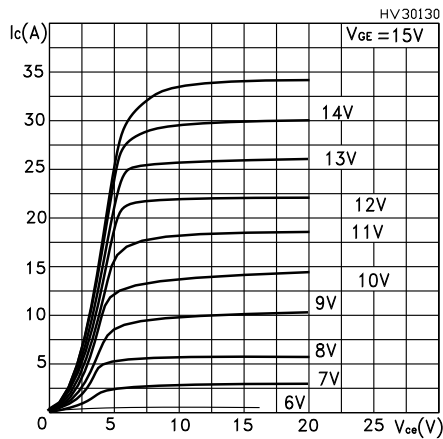
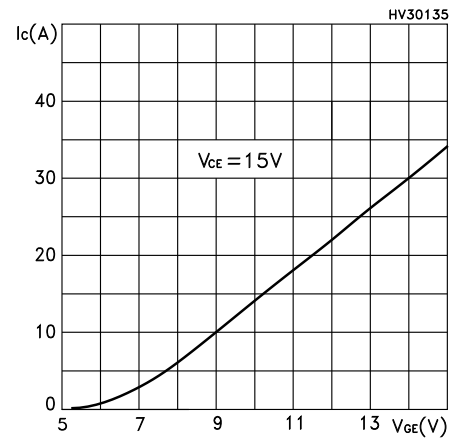
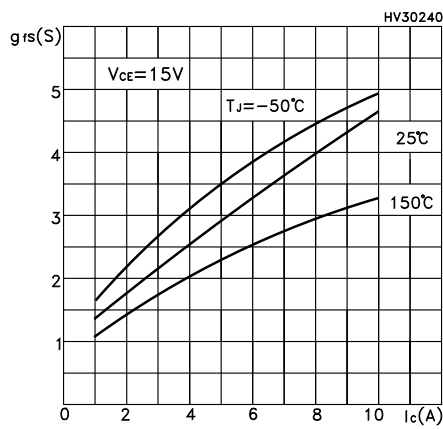
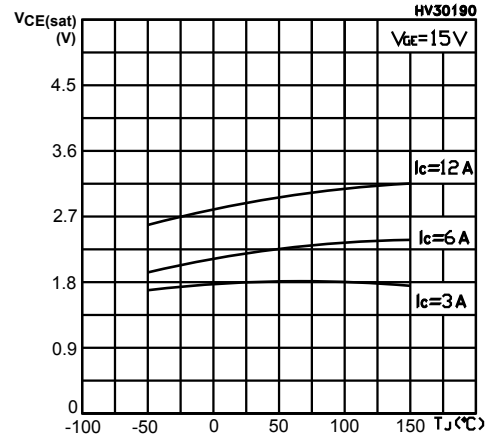
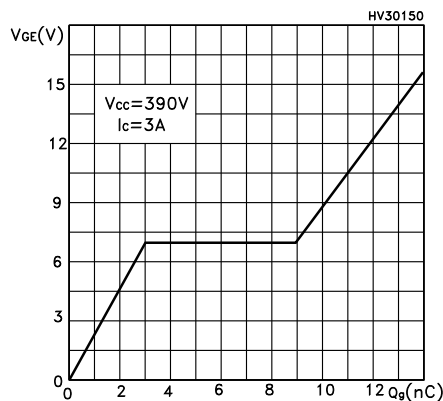
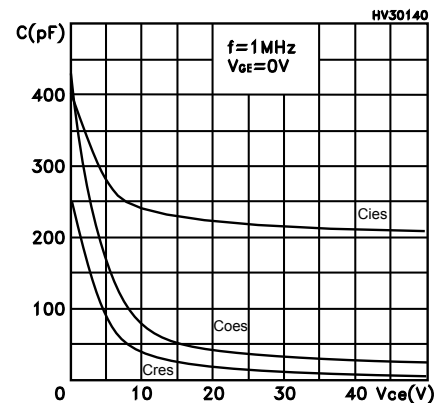
Figure 6. Capacitance variations

Figure 7. Normalized gate threshold voltage vs temperature

Figure 8. Collector-emitter on voltage vs collector current

Figure 9. Normalized breakdown voltage vs temperature

Figure 10. Switching energy vs temperature

Figure 11. Switching energy vs gate resistance

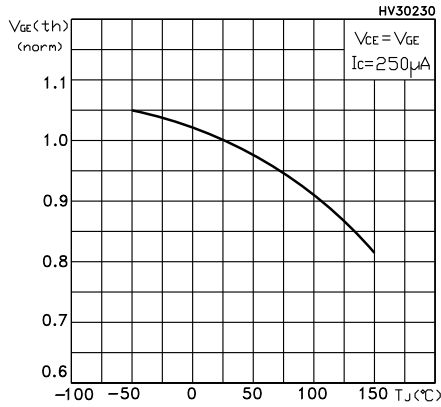
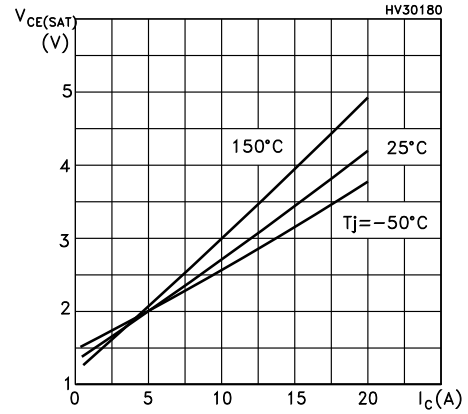
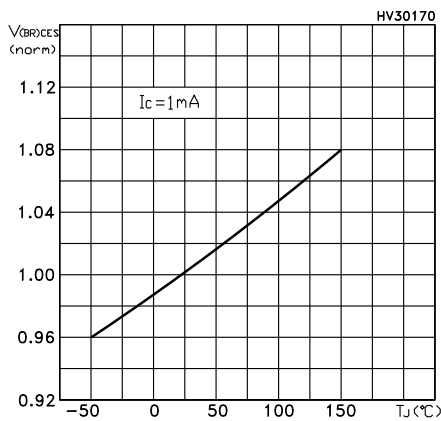
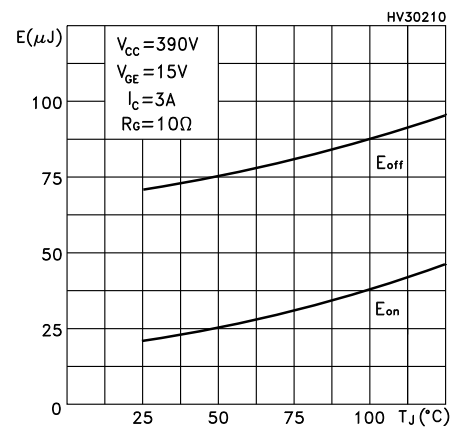
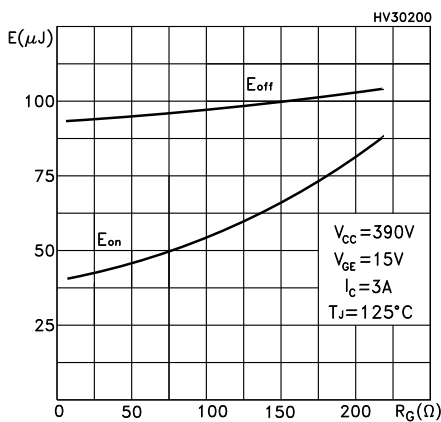
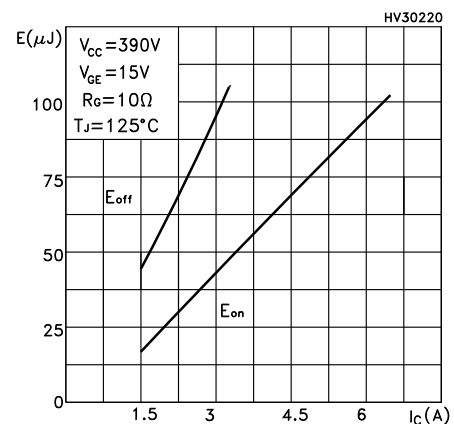
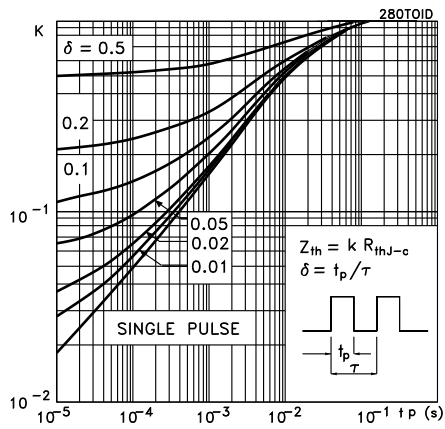
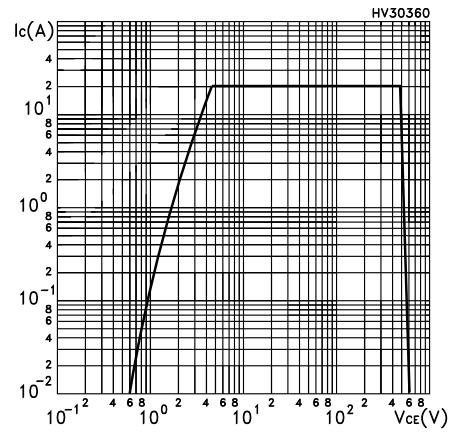
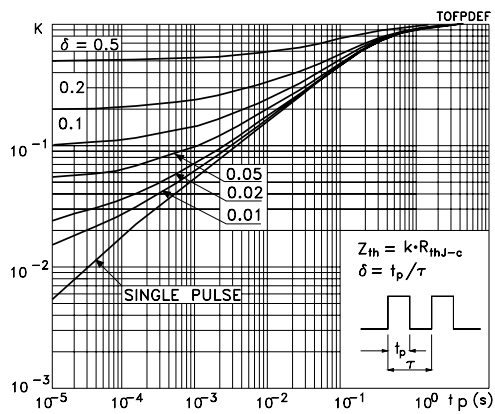
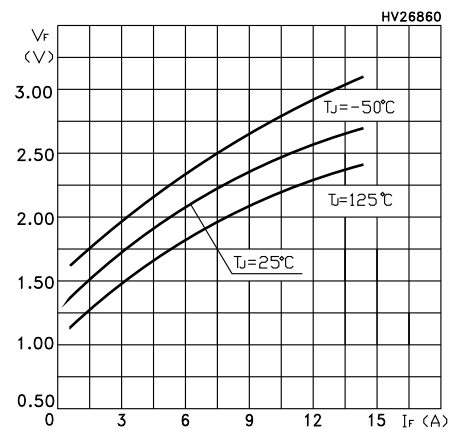
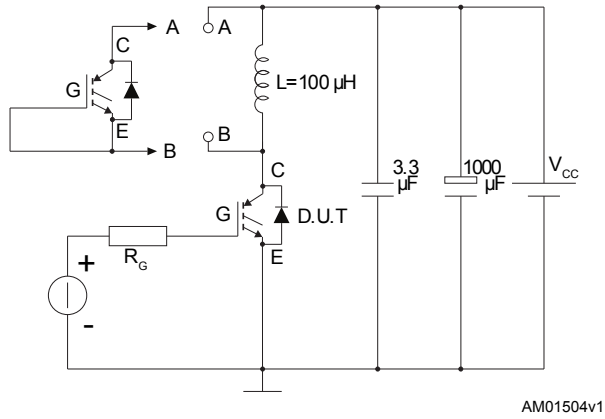
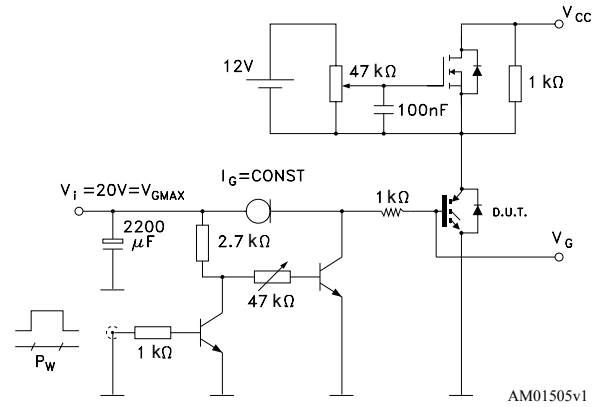
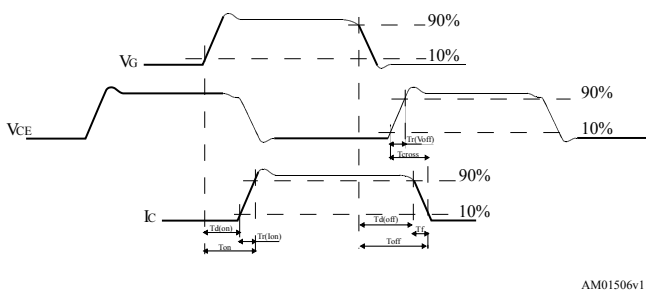
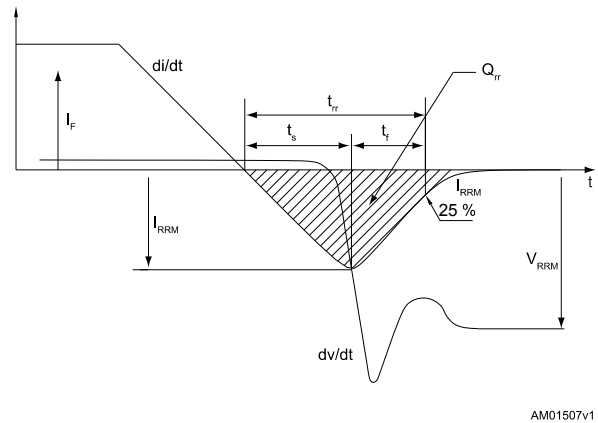
Figure 12. Switching energy vs collector current

Figure 13. Thermal impedance for TO-220 / D²PAK

Figure 14. Turn-off SOA

Figure 15. Thermal impedance for TO-220FP

Figure 16. Emitter-collector diode characteristics

3 Test circuits

Figure 17. Test circuit for inductive load switching

Figure 18. Gate charge test circuit

Figure 19. Switching waveform

Figure 20. Diode reverse recovery waveform

4 Package information

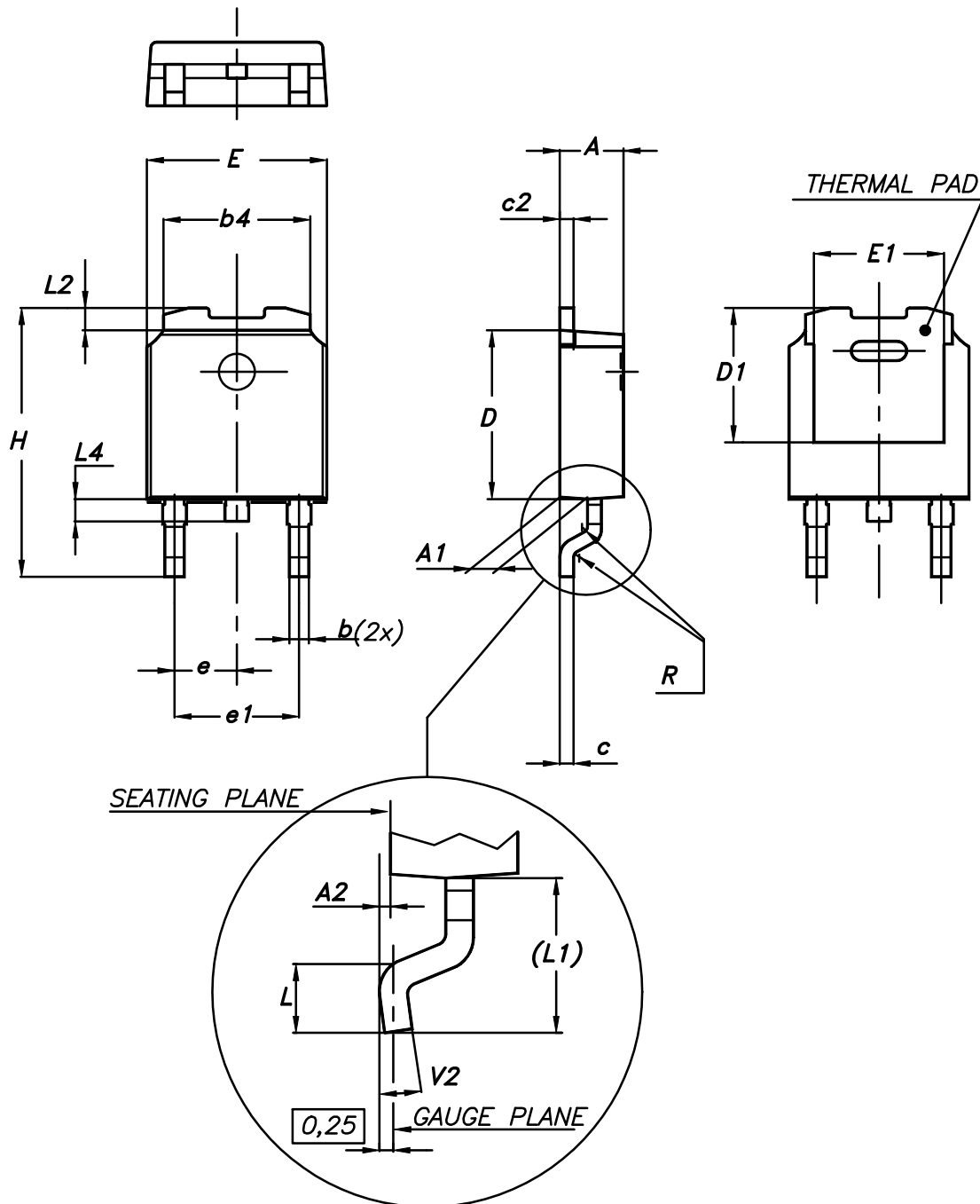
In order to meet environmental requirements, ST offers these devices in different grades of **ECOPACK®** packages, depending on their level of environmental compliance. ECOPACK® specifications, grade definitions and product status are available at: www.st.com. ECOPACK® is an ST trademark.

4.1 D²PAK (TO-263) type A package information

Figure 21. DPAK (TO-252) type A package outline



0068772_A_25

Table 8. DPAK (TO-252) type A mechanical data

Dim.	mm		
	Min.	Typ.	Max.
A	2.20		2.40
A1	0.90		1.10
A2	0.03		0.23
b	0.64		0.90
b4	5.20		5.40
c	0.45		0.60
c2	0.48		0.60
D	6.00		6.20
D1	4.95	5.10	5.25
E	6.40		6.60
E1	4.60	4.70	4.80
e	2.159	2.286	2.413
e1	4.445	4.572	4.699
H	9.35		10.10
L	1.00		1.50
(L1)	2.60	2.80	3.00
L2	0.65	0.80	0.95
L4	0.60		1.00
R		0.20	
V2	0°		8°

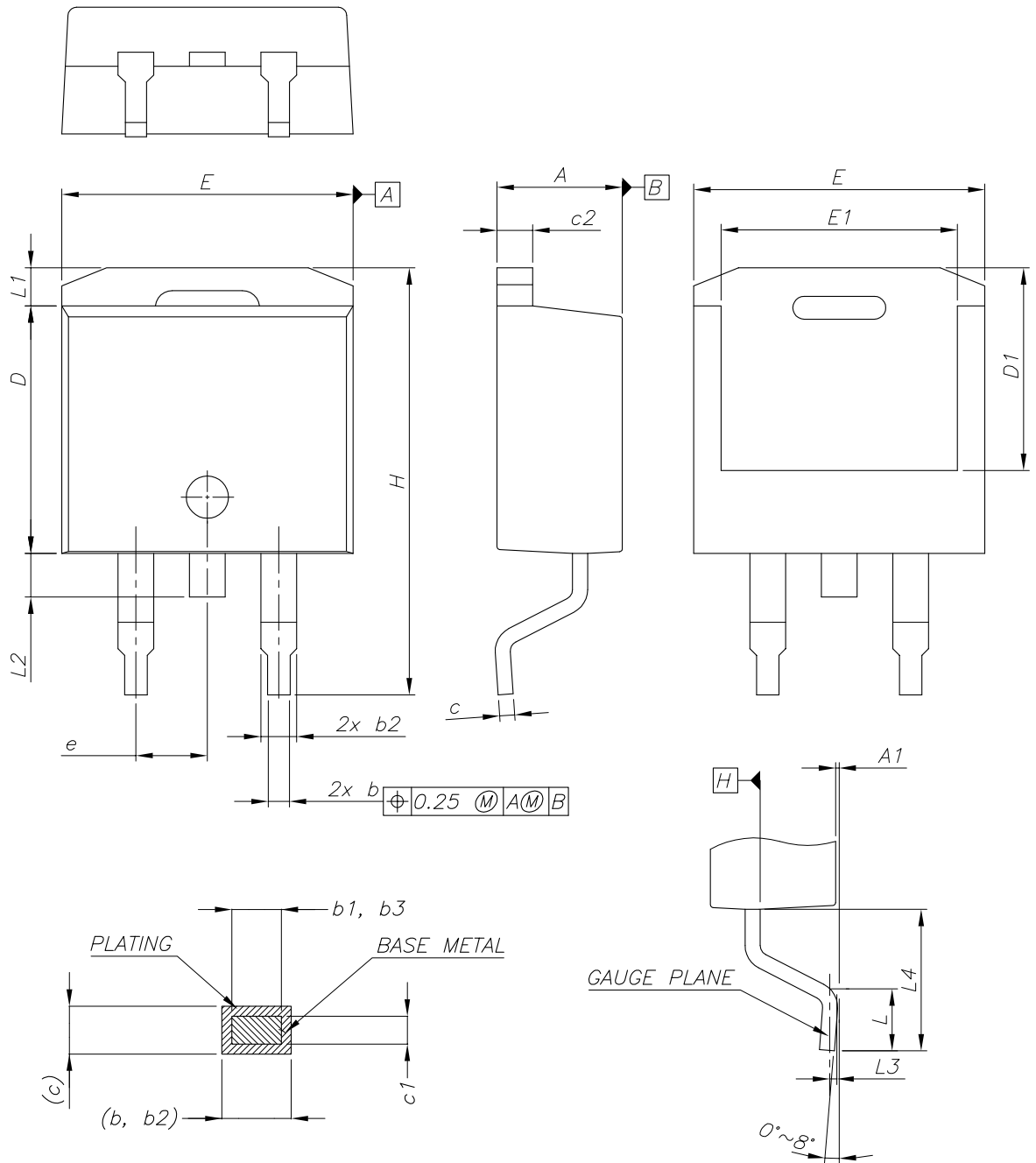
4.2 D²PAK (TO-263) type B package information
Figure 22. D²PAK (TO-263) type B package outline

0079457_25_B

Table 9. D²PAK (TO-263) type B mechanical data

Dim.	mm		
	Min.	Typ.	Max.
A	4.36		4.56
A1	0		0.25
b	0.70		0.90
b1	0.51		0.89
b2	1.17		1.37
b3	1.36		1.46
c	0.38		0.694
c1	0.38		0.534
c2	1.19		1.34
D	8.60		9.00
D1	6.90		7.50
E	10.15		10.55
E1	8.10		8.70
e	2.54 BSC		
H	15.00		15.60
L	1.90		2.50
L1			1.65
L2			1.78
L3		0.25	
L4	4.78		5.28

Figure 23. D²PAK (TO-263) recommended footprint (dimensions are in mm)

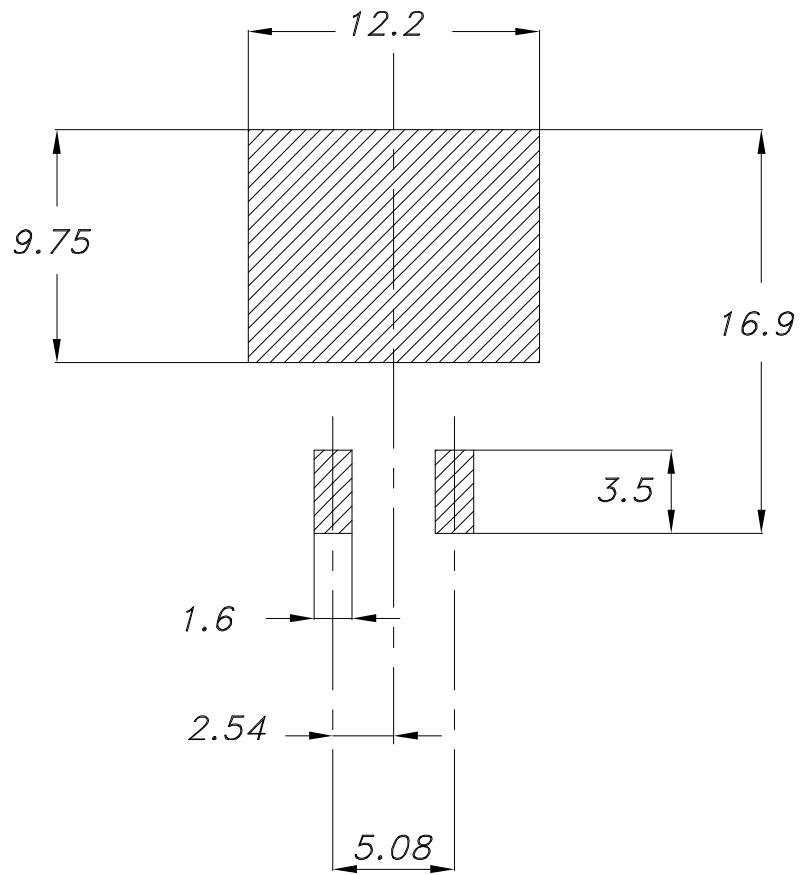

Footprint

4.2.1 Packing information

Figure 24. D²PAK tape outline

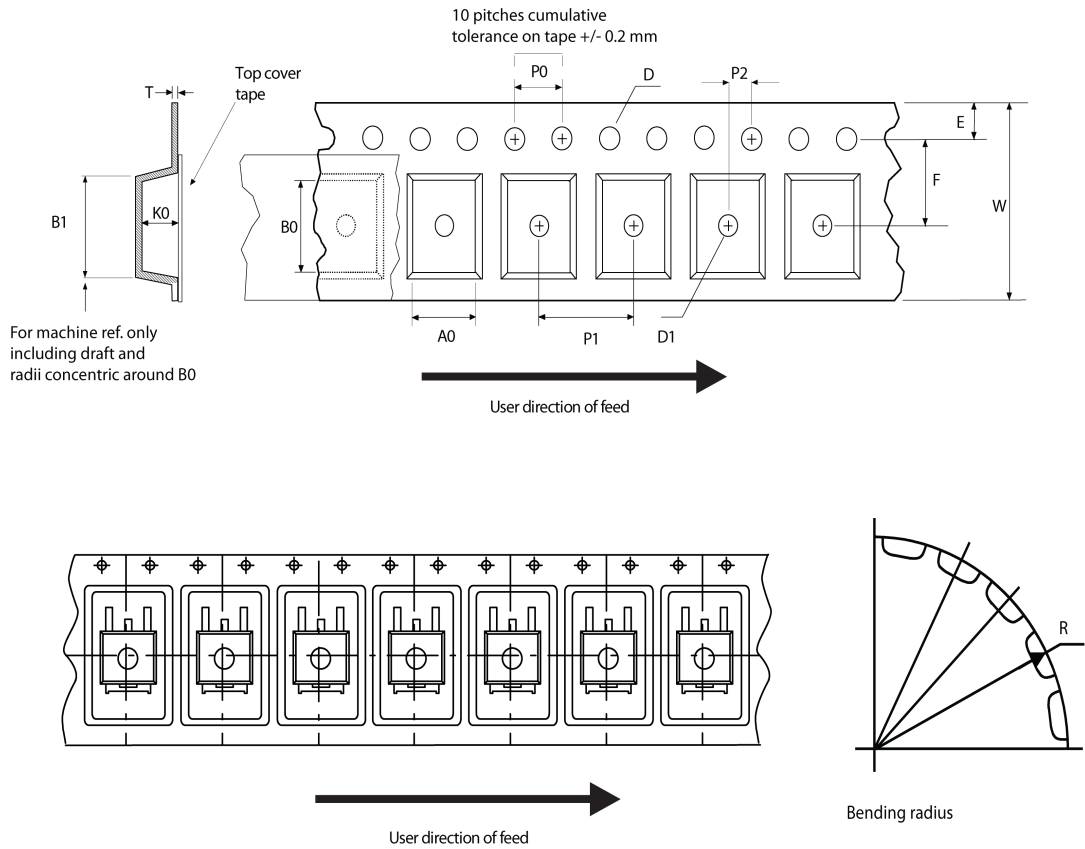

AM08852v1

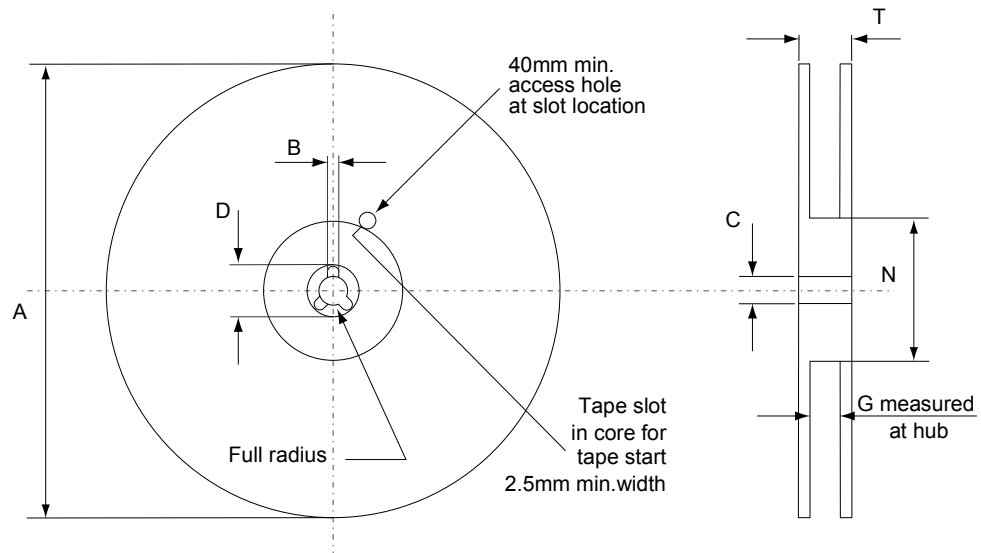
Figure 25. D²PAK reel outline

AM06038v1

Table 10. D²PAK tape and reel mechanical data

Tape			Reel		
Dim.	mm		Dim.	mm	
	Min.	Max.		Min.	Max.
A0	10.5	10.7	A		330
B0	15.7	15.9	B	1.5	
D	1.5	1.6	C	12.8	13.2
D1	1.59	1.61	D	20.2	
E	1.65	1.85	G	24.4	26.4
F	11.4	11.6	N	100	
K0	4.8	5.0	T		30.4
P0	3.9	4.1			
P1	11.9	12.1	Base quantity		1000
P2	1.9	2.1	Bulk quantity		1000
R	50				
T	0.25	0.35			
W	23.7	24.3			

4.3 TO-220FP package information

Figure 26. TO-220FP package outline

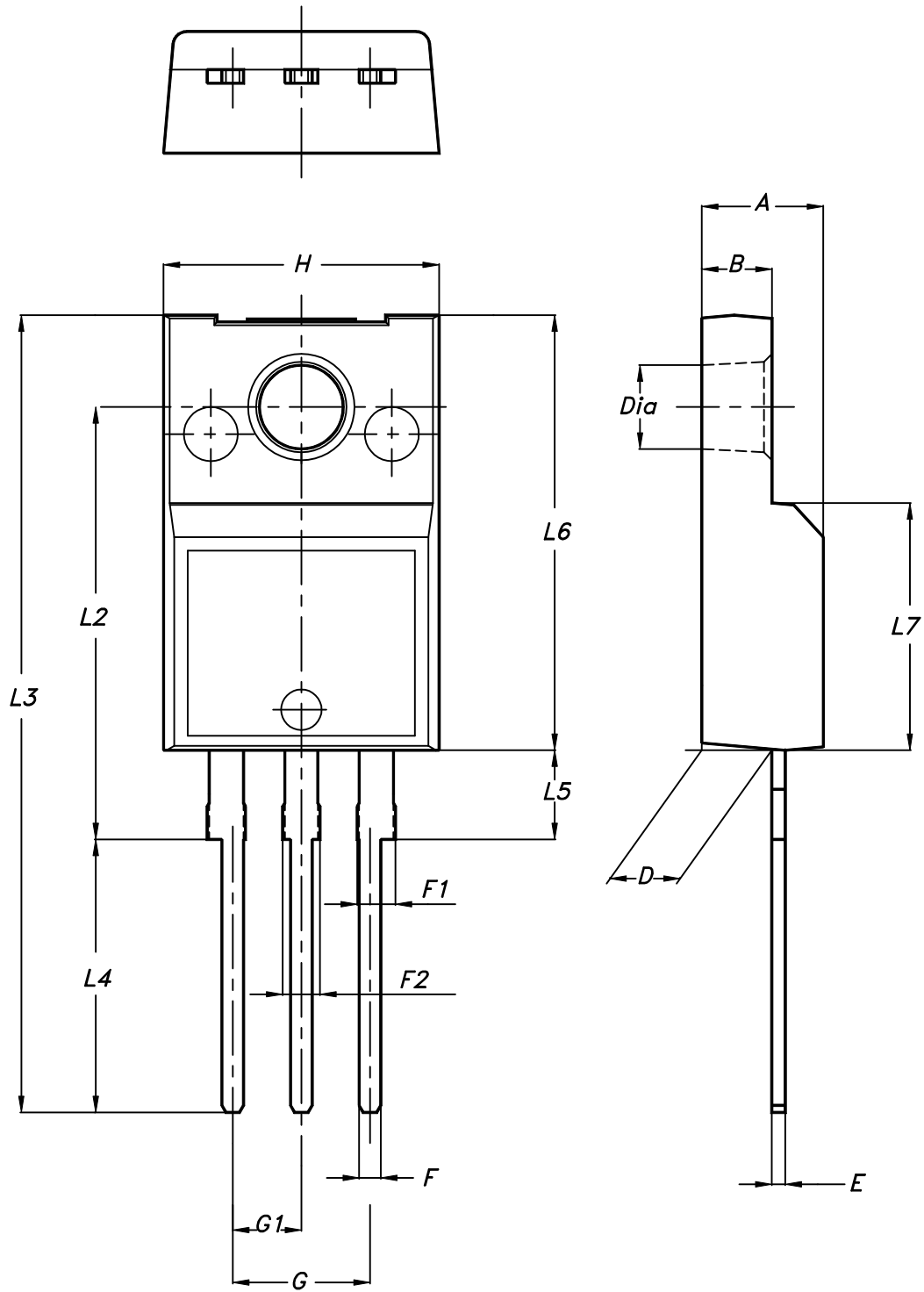

7012510_Rev_12_B

Table 11. TO-220FP package mechanical data

Dim.	mm		
	Min.	Typ.	Max.
A	4.4		4.6
B	2.5		2.7
D	2.5		2.75
E	0.45		0.7
F	0.75		1
F1	1.15		1.70
F2	1.15		1.70
G	4.95		5.2
G1	2.4		2.7
H	10		10.4
L2		16	
L3	28.6		30.6
L4	9.8		10.6
L5	2.9		3.6
L6	15.9		16.4
L7	9		9.3
Dia	3		3.2

4.4 TO-220 type A package information

Figure 27. TO-220 type A package outline

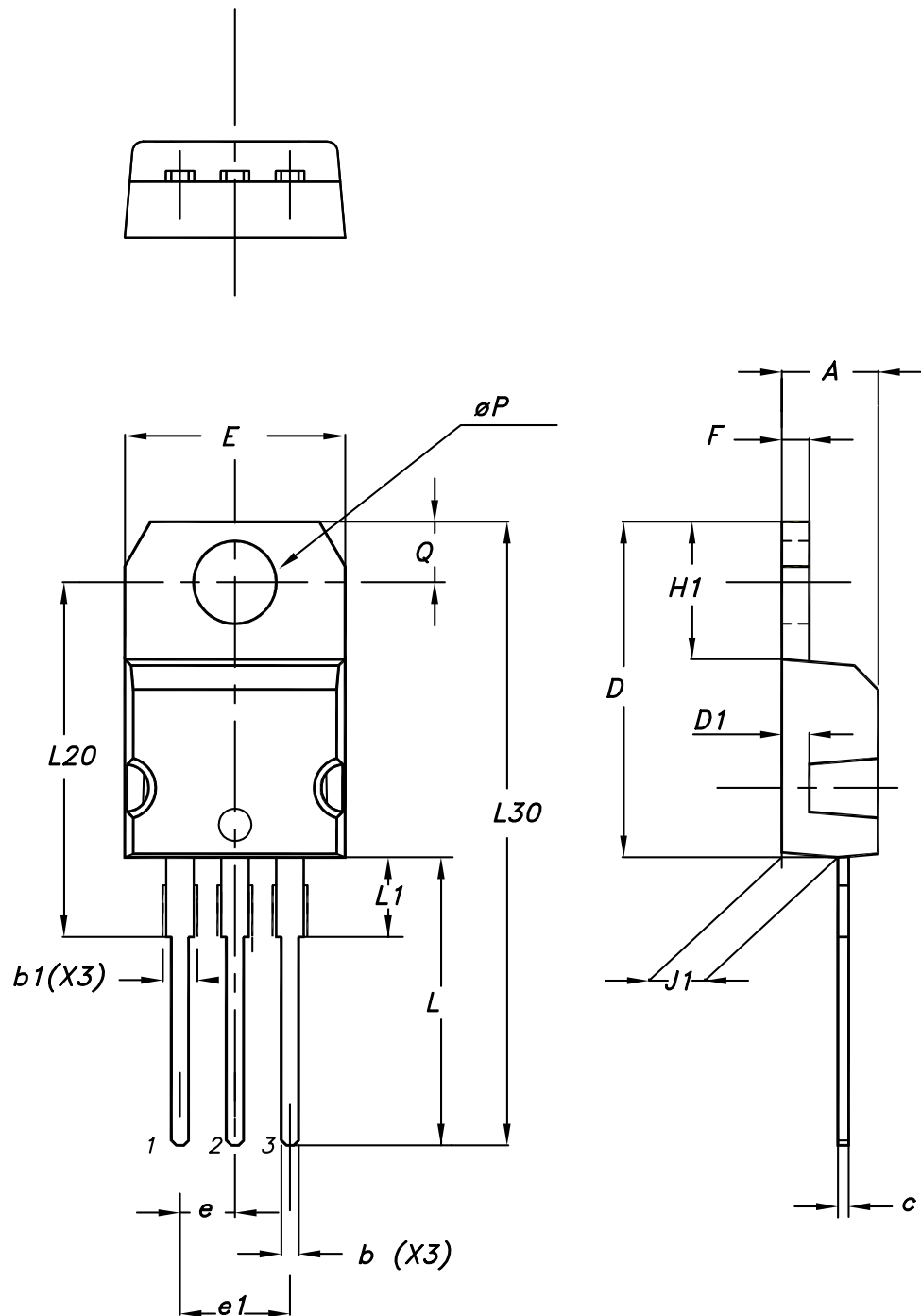

0015988_typeA_Rev_22

Table 12. TO-220 type A package mechanical data

Dim.	mm		
	Min.	Typ.	Max.
A	4.40		4.60
b	0.61		0.88
b1	1.14		1.55
c	0.48		0.70
D	15.25		15.75
D1		1.27	
E	10.00		10.40
e	2.40		2.70
e1	4.95		5.15
F	1.23		1.32
H1	6.20		6.60
J1	2.40		2.72
L	13.00		14.00
L1	3.50		3.93
L20		16.40	
L30		28.90	
øP	3.75		3.85
Q	2.65		2.95

5 Ordering information

Table 13. Ordering information

Order code	Marking	Package	Packing
STGB6NC60HDT4	GB6NC60HD	D ² PAK	Tape and reel
STGF6NC60HD	GF6NC60HD	TO-220FP	Tube
STGP6NC60HD	GP6NC60HD	TO-220	Tube

Revision history

Table 14. Document revision history

Date	Revision	Changes
28-Nov-2005	1	First release
07-Mar-2006	2	Complete version
31-Jul-2006	3	Modified <i>Figure 10</i> .
26-Apr-2007	4	Inserted package I ² PAK
20-Nov-2017	5	<p>Part number STGB6NC60HD-1 has been moved to a separate datasheet.</p> <p>Updated information on cover page.</p> <p>Updated <i>Table 2: "Absolute maximum ratings"</i> and <i>Table 4: "Static characteristics"</i>.</p> <p>Updated <i>Section 2.1: "Electrical characteristics (curves)"</i>.</p> <p>Updated <i>Section 4: "Package information"</i>.</p> <p>Minor text changes</p>
23-Oct-2018	6	<p>Updated title in coverpage and Table 4. Dynamic characteristics.</p> <p>Minor text changes.</p>

Contents

1	Electrical ratings	2
2	Electrical characteristics	3
2.1	Electrical characteristics (curves)	5
3	Test circuits	8
4	Package information	9
4.1	D ² PAK (TO-263) type A package information	9
4.2	D ² PAK (TO-263) type B package information	11
4.2.1	Packing information	15
4.3	TO-220FP package information	16
4.4	TO-220 package information	18
5	Ordering information	21
	Revision history	22



IMPORTANT NOTICE – PLEASE READ CAREFULLY

STMicroelectronics NV and its subsidiaries (“ST”) reserve the right to make changes, corrections, enhancements, modifications, and improvements to ST products and/or to this document at any time without notice. Purchasers should obtain the latest relevant information on ST products before placing orders. ST products are sold pursuant to ST’s terms and conditions of sale in place at the time of order acknowledgement.

Purchasers are solely responsible for the choice, selection, and use of ST products and ST assumes no liability for application assistance or the design of Purchasers’ products.

No license, express or implied, to any intellectual property right is granted by ST herein.

Resale of ST products with provisions different from the information set forth herein shall void any warranty granted by ST for such product.

ST and the ST logo are trademarks of ST. All other product or service names are the property of their respective owners.

Information in this document supersedes and replaces information previously supplied in any prior versions of this document.

© 2018 STMicroelectronics – All rights reserved



Looking for pricing, stock, or lifecycle information?

Click below to explore more details on WIN SOURCE:

 [View STGP6NC60HD](#) on WIN SOURCE

 [STMicroelectronics](#) Information

Optimize Your Supply Chain with WIN SOURCE Solutions

-  Global Sourcing Solution
-  Obsolete Management
-  Cost Control Management
-  Shortage Management
-  Alternative Solution
-  Excess Inventory Management