



**THE DATASHEET OF  
TLC59482DBQR**



## 16-Channel, 16-Bit, PWM LED Driver with 6-Bit Global Brightness Control

Check for Samples: [TLC59482](#)

### FEATURES

- 16 Constant-Current Sink Output Channels
- Sink Current Capability with Max BC Data:
  - 1 mA to 35 mA ( $V_{CC} \leq 3.6\text{ V}$ )
  - 1 mA to 45 mA ( $V_{CC} > 3.6\text{ V}$ )
- Global Brightness Control (BC):
  - 6-Bit (64 Steps) with 0% to 100% Range (default is 50%)
- LED Power-Supply Voltage: Up to 10 V
- VCC: 3.0 V to 5.5 V
- Constant-Current Accuracy:
  - Channel-to-Channel:  $\pm 1\%$  (typ),  $\pm 2.5\%$  (max)
  - Device-to-Device:  $\pm 2\%$  (typ),  $\pm 4\%$  (max)
- Data Transfer Rate: 30 MHz
- Grayscale Control Clock: 33 MHz
- Auto Display Repeat
- Auto Data Refresh
- Display Timing Reset
- Four-Channel Grouped Delay Switching to Prevent Inrush Current
- Operating Temperature:  $-40^{\circ}\text{C}$  to  $+85^{\circ}\text{C}$

### APPLICATIONS

- LED Video Displays
- LED Signboards

### DESCRIPTION

The TLC59482 is a 16-channel, constant-current sink driver. Each channel has an individually-adjustable, pulse width modulation (PWM) grayscale (GS) brightness control with 65,536 steps. All channels have a 64-step global brightness control (BC). BC adjusts brightness deviation with other LED drivers. GS and BC data are accessible via a serial interface port.

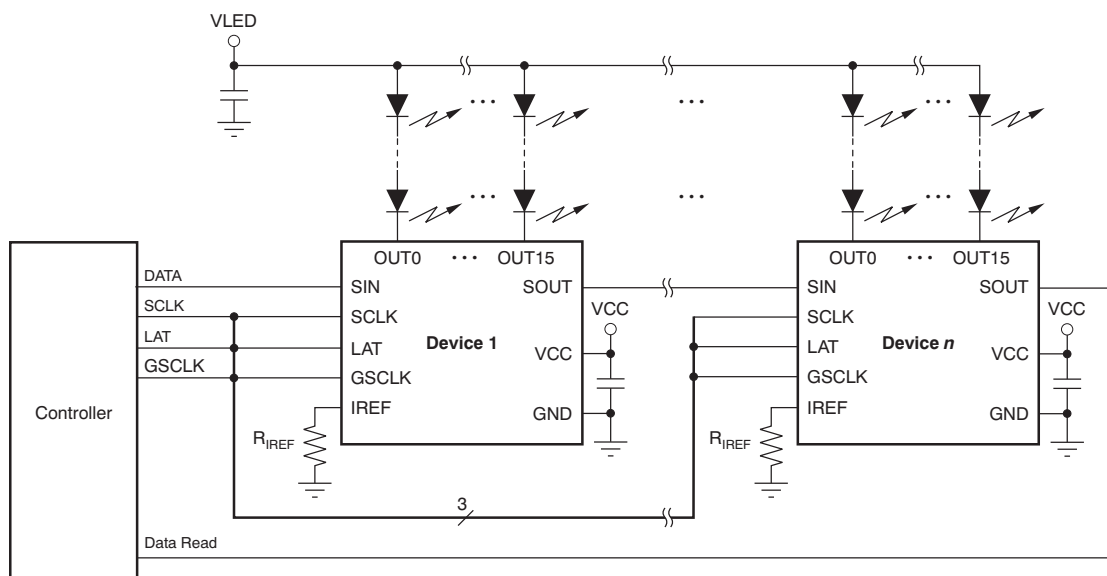

**Typical Application Circuit (Multiple Daisy-Chained TLC59482s)**



Please be aware that an important notice concerning availability, standard warranty, and use in critical applications of Texas Instruments semiconductor products and disclaimers thereto appears at the end of this data sheet.

All trademarks are the property of their respective owners.

ESD damage can range from subtle performance degradation to complete device failure. Precision integrated circuits may be more susceptible to damage because very small parametric changes could cause the device not to meet its published specifications.

This integrated circuit can be damaged by ESD. Texas Instruments recommends that all integrated circuits be handled with appropriate precautions. Failure to observe proper handling and installation procedures can cause damage.



ESD damage can range from subtle performance degradation to complete device failure. Precision integrated circuits may be more susceptible to damage because very small parametric changes could cause the device not to meet its published specifications.

### ORDERING INFORMATION<sup>(1)</sup>

PRODUCT	PACKAGE DESIGNATOR	ORDERING NUMBER	TRANSPORT MEDIA, QUANTITY
TLC59482	DBQ	TLC59482DBQR	Tape and Reel, 2500
		TLC59482DBQ	Tube, 50
	RGE <sup>(2)</sup>	TLC59482RGER	Tape and Reel, 3000
		TLC59482RGET	Tape and Reel, 250

(1) For the most current package and ordering information, see the Package Option Addendum at the end of this document, or visit the device product folder at [www.ti.com](http://www.ti.com).

(2) Product preview device.

### ABSOLUTE MAXIMUM RATINGS<sup>(1)</sup>

Over operating free-air temperature range, unless otherwise noted.

		VALUE		UNIT
		MIN	MAX	
Voltage <sup>(2)</sup>	VCC	-0.3	+6	V
	SIN, SCLK, LAT, GSCLK, IREF	-0.3	V <sub>CC</sub> + 0.3	V
	SOUT	-0.3	V <sub>CC</sub> + 0.3	V
	OUT0 to OUT15	-0.3	+11	V
Current	I <sub>OUT</sub> (dc), OUT0 to OUT15		+55	mA
Temperature	Operating junction, T <sub>J</sub> (max)		+150	°C
	Storage, T <sub>stg</sub>	-55	+150	°C
Electrostatic discharge (ESD) ratings	Human body model (HBM)		3000	V
	Charged device model (CDM)		2000	V

(1) Stresses beyond those listed under *Absolute Maximum Ratings* may cause permanent damage to the device. These are stress ratings only, and do not imply functional operation of the device at these or any other conditions beyond those indicated under *Recommended Operating Conditions*. Exposure to absolute-maximum-rated conditions for extended periods may affect device reliability.

(2) All voltages are with respect to device ground terminal.

### THERMAL INFORMATION

THERMAL METRIC <sup>(1)</sup>	TLC59482		UNITS
	DBQ (SSOP, QSOP)	RGE (QFN)	
	24 PINS	24 PINS	
$\theta_{JA}$ Junction-to-ambient thermal resistance	86.7	35.5	°C/W
$\theta_{JCTop}$ Junction-to-case (top) thermal resistance	50.4	44	
$\theta_{JB}$ Junction-to-board thermal resistance	10.0	14.7	
$\Psi_{JT}$ Junction-to-top characterization parameter	13.0	0.4	
$\Psi_{JB}$ Junction-to-board characterization parameter	39.7	14.8	
$\theta_{JCbott}$ Junction-to-case (bottom) thermal resistance	N/A	2.9	

(1) For more information about traditional and new thermal metrics, see the *IC Package Thermal Metrics* application report, [SPRA953](http://www.ti.com).

## RECOMMENDED OPERATING CONDITIONS

 At  $T_A = -40^{\circ}\text{C}$  to  $+85^{\circ}\text{C}$ , unless otherwise noted.

PARAMETER		TEST CONDITIONS	MIN	NOM	MAX	UNIT
<b>DC CHARACTERISTICS (<math>V_{CC} = 3\text{ V to }5.5\text{ V}</math>)</b>						
$V_{CC}$	Supply voltage		3.0		5.5	V
$V_O$	Voltage applied to output	OUT0 to OUT15			10	V
$V_{IH}$	High-level input voltage	SIN, SCLK, LAT, GSCLK	$0.7 \times V_{CC}$		$V_{CC}$	V
$V_{IL}$	Low-level input voltage	SIN, SCLK, LAT, GSCLK	GND		$0.3 \times V_{CC}$	V
$I_{OH}$	High-level output current	SOUT			-2	mA
$I_{OL}$	Low-level output current	SOUT			2	mA
$I_{OLC}$	Constant output sink current	OUT0 to OUT15, $3\text{ V} \leq V_{CC} \leq 3.6\text{ V}$			35	mA
		OUT0 to OUT15, $3.6\text{ V} < V_{CC} \leq 5.5\text{ V}$			45	mA
$T_A$	Operating free-air temperature range		-40		+85	$^{\circ}\text{C}$
$T_J$	Operating junction temperature range		-40		+125	$^{\circ}\text{C}$
<b>AC CHARACTERISTICS (<math>V_{CC} = 3\text{ V to }5.5\text{ V}</math>)</b>						
$V_{CC}$	Supply voltage		3.0		5.5	V
$f_{CLK}$ (SCLK)	Data shift clock frequency	SCLK, $3.0\text{ V} \leq V_{CC} \leq 3.6\text{ V}$			25	MHz
		SCLK, $3.6\text{ V} < V_{CC} \leq 5.5\text{ V}$			30	MHz
$f_{CLK}$ (GSCLK)	Grayscale control clock frequency	GSCLK			33	MHz
$t_{WH0}$	Pulse duration	SCLK	10			ns
$t_{WL0}$		SCLK	10			ns
$t_{WH1}$		GSCLK	10			ns
$t_{WL1}$		GSCLK	10			ns
$t_{WH2}$		LAT	10			ns
$t_{SU0}$	Setup time	SIN to SCLK $\uparrow$	4			ns
$t_{SU1}$		LAT $\uparrow$ to SCLK $\uparrow$	2			ns
$t_{SU2}$		LAT $\downarrow$ to SCLK $\uparrow$ <sup>(1)</sup>	5			ns
$t_{H0}$	Hold time	SCLK $\uparrow$ to SIN	4			ns
$t_{H1}$		SCLK $\uparrow$ to LAT $\uparrow$	7			ns
$t_{H2}$		SCLK $\uparrow$ to LAT $\downarrow$	14			ns
$t_{H3}$		LAT $\downarrow$ to GSCLK $\uparrow$	30			ns

 (1) Refer to the  $t_{D1}$  parameter in the [Switching Characteristics](#) table for the FC data read time.

## ELECTRICAL CHARACTERISTICS

At  $T_A = -40^\circ\text{C}$  to  $+85^\circ\text{C}$  and  $V_{CC} = 3\text{ V}$  to  $5.5\text{ V}$ , unless otherwise noted. Typical values are at  $T_A = +25^\circ\text{C}$  and  $V_{CC} = 3.3\text{ V}$ .

PARAMETER		TEST CONDITIONS	MIN	TYP	MAX	UNIT
$V_{OH}$	High-level output voltage (SOUT)	$I_{OH} = -2\text{ mA}$	$V_{CC} - 0.4$		$V_{CC}$	V
$V_{OL}$	Low-level output voltage (SOUT)	$I_{OL} = 2\text{ mA}$			0.4	V
$V_{IREF}$	Reference voltage output	$R_{IREF} = 1.5\text{ k}\Omega$	1.175	1.200	1.225	V
$I_{IN}$	Input current (SIN, SCLK, GSCLK)	$V_{IN} = V_{CC}$ or GND	-1		1	$\mu\text{A}$
$I_{CC0}$	Supply current ( $V_{CC}$ )	SIN, SCLK, LAT, GSCLK = GND, $GS_n = 0000h$ , BC = 3Fh, $V_{OUTn} = 0.8\text{ V}$ , $R_{IREF} = \text{open}$		1.5	3	mA
$I_{CC1}$		SIN, SCLK, LAT, GSCLK = GND, $GS_n = 0000h$ , BC = 3Fh, $V_{OUTn} = 0.8\text{ V}$ , $R_{IREF} = 3\text{ k}\Omega$ ( $I_{OUTn} = 15.9\text{-mA target}$ )		3	5	mA
$I_{CC2}$		SIN, SCLK, LAT = GND, GSCLK = 33 MHz, $GS_n = FFFFh$ , BC = 3Fh, $V_{OUTn} = 0.8\text{ V}$ , $R_{IREF} = 3\text{ k}\Omega$ ( $I_{OUT} = 15.9\text{-mA target}$ )		8	10	mA
$I_{CC3}$		SIN, SCLK, LAT = GND, GSCLK = 33 MHz, $GS_n = FFFFh$ , BC = 3Fh, $V_{OUTn} = 0.8\text{ V}$ , $R_{IREF} = 1.5\text{ k}\Omega$ ( $I_{OUT} = 31.8\text{-mA target}$ )		9	13.5	mA
$I_{OLC}$	Constant output sink current (OUT0 to OUT15)	All $OUT_n = \text{on}$ , BC = 3Fh, $V_{OUTn} = V_{OUTfix} = 0.8\text{ V}$ , $R_{IREF} = 1.5\text{ k}\Omega$ , $T_A = +25^\circ\text{C}$ ( $I_{OLCn} = 31.8\text{-mA target}$ )	29.8	31.8	33.8	mA
$I_{OLKG0}$	Output leakage current (OUT0 to OUT15)	All $OUT_n = \text{off}$ , $GS_n = 0000h$ , $V_{OUTn} = V_{OUTfix} = 10\text{ V}$ , $R_{IREF} = 1.5\text{ k}\Omega$ ( $I_{OLCn} = 31.8\text{-mA target}$ )			0.1	$\mu\text{A}$
$I_{OLKG1}$					0.2	$\mu\text{A}$
$I_{OLKG2}$					0.3	0.8
$\Delta I_{OLC0}$	Constant-current error, channel-to-channel (OUT0 to OUT15) <sup>(2)</sup>	All $OUT_n = \text{on}$ , BC = 3Fh, $V_{OUTn} = V_{OUTfix} = 0.8\text{ V}$ , $R_{IREF} = 1.5\text{ k}\Omega$ , $T_A = +25^\circ\text{C}$ ( $I_{OUTn} = 31.8\text{-mA target}$ )		$\pm 1\%$	$\pm 2.5\%$	
$\Delta I_{OLC1}$	Constant-current error, device-to-device (OUT0 to OUT15) <sup>(3)</sup>	All $OUT_n = \text{on}$ , BC = 3Fh, $V_{OUTn} = V_{OUTfix} = 0.8\text{ V}$ , $R_{IREF} = 1.5\text{ k}\Omega$ , $T_A = +25^\circ\text{C}$ ( $I_{OUTn} = 31.8\text{-mA target}$ )		$\pm 2\%$	$\pm 4\%$	
$\Delta I_{OLC2}$	Line regulation (OUT0 to OUT15) <sup>(4)</sup>	$V_{CC} = 3.0\text{ V}$ to $5.5\text{ V}$ , all $OUT_n = \text{on}$ , BC = 3Fh, $V_{OUTn} = V_{OUTfix} = 0.8\text{ V}$ , $R_{IREF} = 1.5\text{ k}\Omega$ ( $I_{OUTn} = 31.8\text{-mA target}$ )		$\pm 1$	$\pm 3$	%/V
$\Delta I_{OLC3}$	Load regulation (OUT0 to OUT15) <sup>(5)</sup>	All $OUT_n = \text{on}$ , BC = 3Fh, $V_{OUTn} = 0.8\text{ V}$ to $3.0\text{ V}$ , $V_{OUTfix} = 0.8\text{ V}$ , $R_{IREF} = 1.5\text{ k}\Omega$ ( $I_{OUTn} = 31.8\text{-mA target}$ )		$\pm 1$	$\pm 3$	%/V
$R_{PDWN}$	Pull-down resistor	LAT	250	500	750	k $\Omega$

(1) Not tested; specified by design.

(2) The deviation of each output from the average of OUT0 to OUT15 constant-current. Deviation is calculated by the formula:

$$\Delta (\%) = \left[ \frac{I_{OLCn}}{I_{OLC0} + I_{OLC1} + \dots + I_{OLC14} + I_{OLC15}} - 1 \right] \times 100$$

where  $n = 0$  to  $15$ .

(3) The deviation of the  $OUT_n$  output current value from the ideal constant-current value. Deviation is calculated by the formula:

$$\Delta (\%) = \left[ \frac{(I_{OLC0} + I_{OLC1} + \dots + I_{OLC14} + I_{OLC15})}{16} - \text{Ideal Output Current} \right] \times 100$$

Ideal current is calculated by the formula:

$$I_{OLCn(\text{IDEAL})} (\text{mA}) = 39.8 \times \left[ \frac{1.20}{R_{IREF} (\Omega)} \right]$$

where  $n = 0$  to  $15$ .

(4) Line regulation is calculated by the formula:

$$\Delta (\%/V) = \left[ \frac{(I_{OLCn} \text{ at } V_{CC} = 5.5\text{ V}) - (I_{OLCn} \text{ at } V_{CC} = 3.0\text{ V})}{I_{OLCn} \text{ at } V_{CC} = 3.0\text{ V}} \right] \times \frac{100}{5.5\text{ V} - 3\text{ V}}$$

where  $n = 0$  to  $15$ .

(5) Load regulation is calculated by the equation:

$$\Delta (\%/V) = \left[ \frac{(I_{OLCn} \text{ at } V_{OUTn} = 3\text{ V}) - (I_{OLCn} \text{ at } V_{OUTn} = 0.8\text{ V})}{I_{OLCn} \text{ at } V_{OUTn} = 0.8\text{ V}} \right] \times \frac{100}{3\text{ V} - 0.8\text{ V}}$$

where  $n = 0$  to  $15$ .

## SWITCHING CHARACTERISTICS

At  $T_A = -40^\circ\text{C}$  to  $+85^\circ\text{C}$ ,  $V_{CC} = 3\text{ V}$  to  $5.5\text{ V}$ ,  $C_L = 15\text{ pF}$ ,  $R_L = 110\ \Omega$ ,  $R_{REF} = 1.5\text{ k}\Omega$ , and  $V_{LED} = 5.0\text{ V}$ , unless otherwise noted. Typical values are at  $T_A = +25^\circ\text{C}$  and  $V_{CC} = 3.3\text{ V}$ .

PARAMETER		TEST CONDITIONS	MIN	TYP	MAX	UNIT
$t_{R0}$	Rise time	SOUT		1.5	5	ns
$t_{R1}$		OUT $n$ , BC = 7Fh, $T_A = +25^\circ\text{C}$		30		ns
$t_{F0}$	Fall time	SOUT		1.5	5	ns
$t_{F1}$		OUT $n$ , BC = 7Fh, $T_A = +25^\circ\text{C}$		30		ns
$t_{D0}$	Propagation delay	SCLK $\uparrow$ to SOUT $\uparrow\downarrow$		23	35	ns
$t_{D1}$		LAT $\downarrow$ to SOUT $\uparrow\downarrow$		27	42	ns
$t_{D2}$		GSCLK $\uparrow$ to OUT0, OUT7, OUT8, OUT15 on/off with BC = 7Fh, $T_A = +25^\circ\text{C}$		50		ns
$t_{D3}$		GSCLK $\uparrow$ to OUT1, OUT6, OUT9, OUT14 on/off with BC = 7Fh, $T_A = +25^\circ\text{C}$		55		ns
$t_{D4}$		GSCLK $\uparrow$ to OUT2, OUT5, OUT10, OUT13 on/off with BC = 7Fh, $T_A = +25^\circ\text{C}$		60		ns
$t_{D5}$		GSCLK $\uparrow$ to OUT3, OUT4, OUT11, OUT12 on/off with BC = 7Fh, $T_A = +25^\circ\text{C}$		65		ns
$t_{ON\_ERR}$	Output on-time error <sup>(1)</sup>	$t_{OUT\_ON} - t_{GSCLK}$ , GS $n = 0001h$ , GSCLK = 20 MHz, BC = 3Fh, $V_{CC} = 3.3\text{ V}$ , $T_A = +25^\circ\text{C}$	-35		10	ns

- (1) Output on-time error ( $t_{ON\_ERR}$ ) is calculated by the formula:  $t_{ON\_ERR} = t_{OUT\_ON} - t_{GSCLK}$ .  $t_{OUT\_ON}$  is the actual on-time of the constant-current driver.  $t_{GSCLK}$  is the GSCLK period.

PARAMETER MEASUREMENT INFORMATION

PIN-EQUIVALENT INPUT AND OUTPUT SCHEMATIC DIAGRAMS

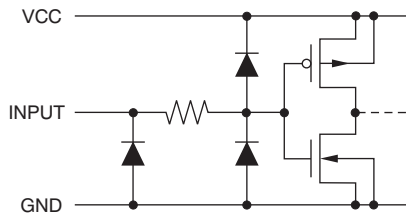

Figure 1. SIN, SCLK, and GSCLK

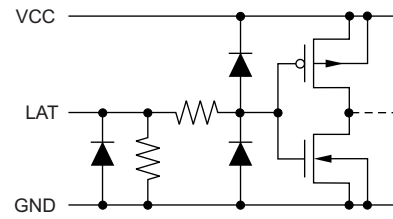

Figure 2. LAT

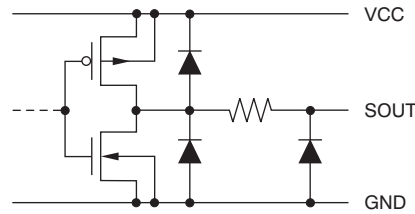
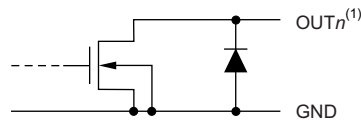

Figure 3. SOUT



(1) n = 0 to 15.

Figure 4. OUT0 Through OUT15

TEST CIRCUITS

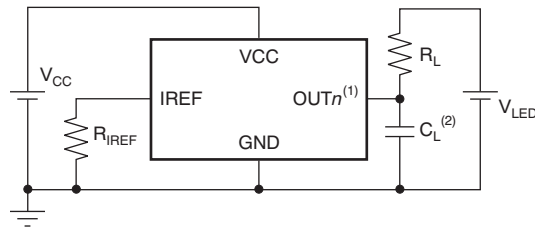

(1)  $n = 0$  to 15.

(2)  $C_L$  includes measurement probe and jig capacitance.

Figure 5. Rise Time and Fall Time Test Circuit for  $OUT_n$

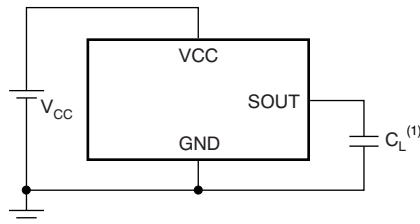

(1)  $C_L$  includes measurement probe and jig capacitance.

Figure 6. Rise Time and Fall Time Test Circuit for SOUT

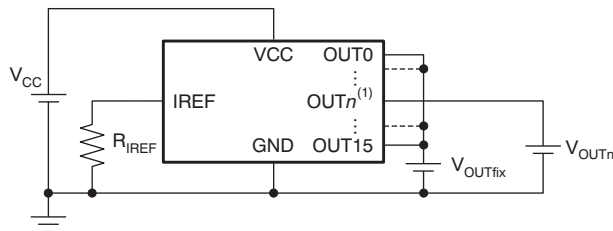

(1)  $n = 0$  to 15.

Figure 7. Constant-Current Test Circuit for  $OUT_n$

**TIMING DIAGRAMS**

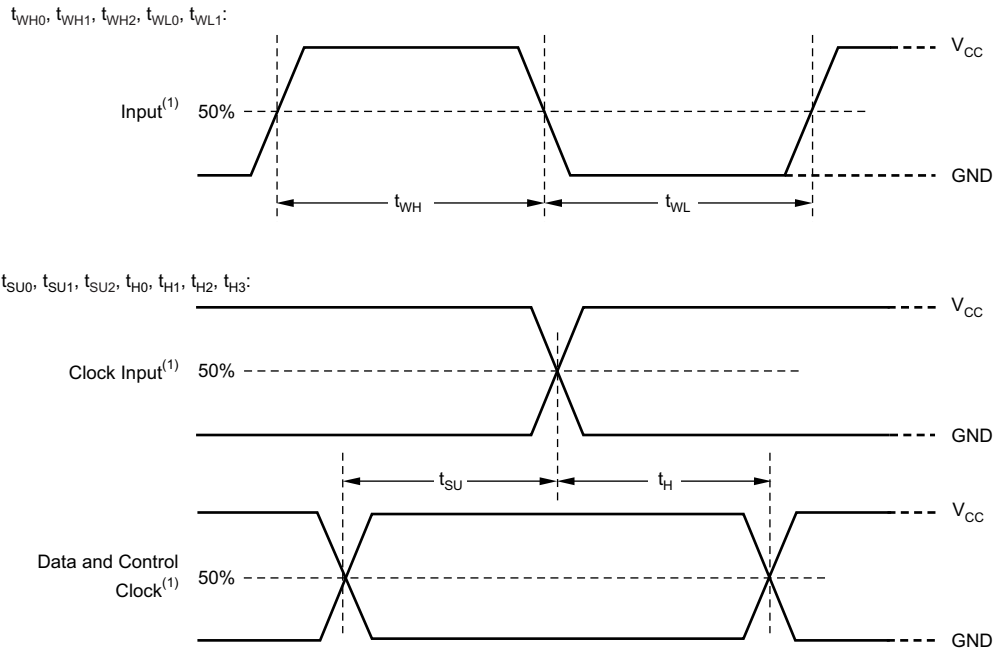

(1) Input pulse rise and fall time is 1 ns to 3 ns.

**Figure 8. Input Timing**

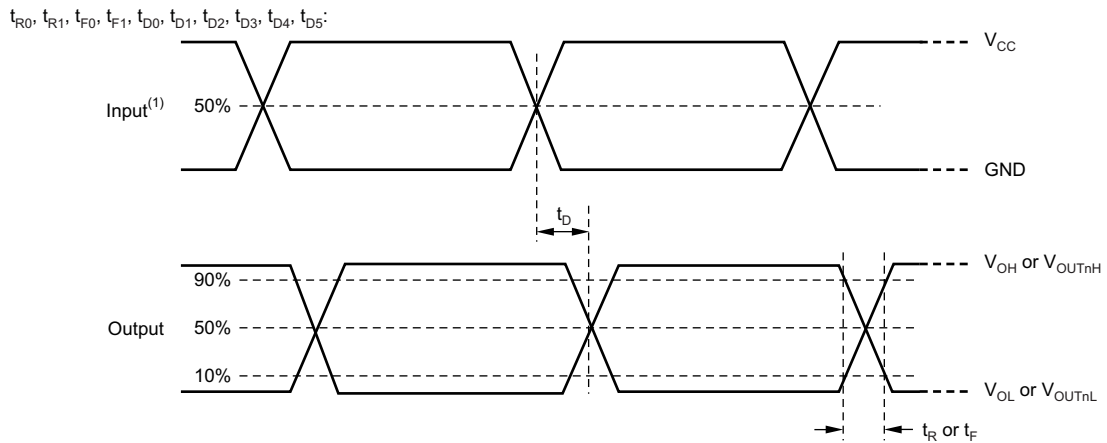

(1) Input pulse rise and fall time is 1 ns to 3 ns.

**Figure 9. Output Timing**

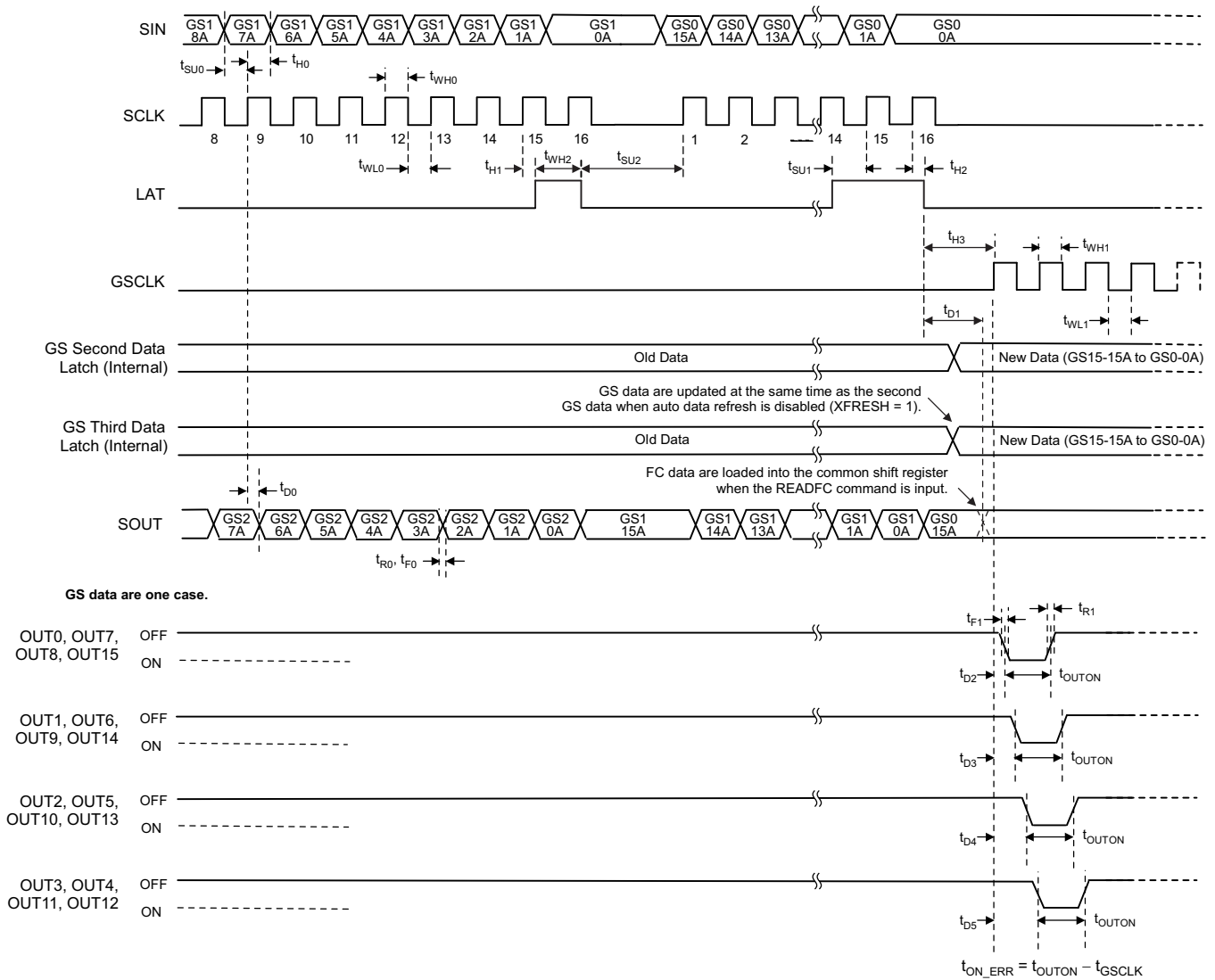

(1) NV = Not valid; these data are not used for any function.

Figure 10. Timing Diagram

### PIN CONFIGURATIONS

**DBQ PACKAGE  
SSOP-24, QSOP-24  
(Top View)**

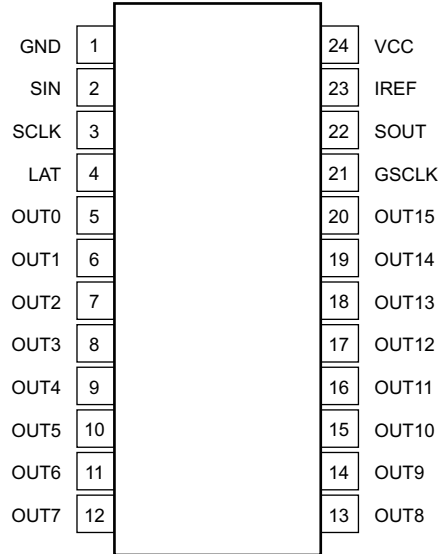

**RGE PACKAGE  
QFN-24  
(Top View)**

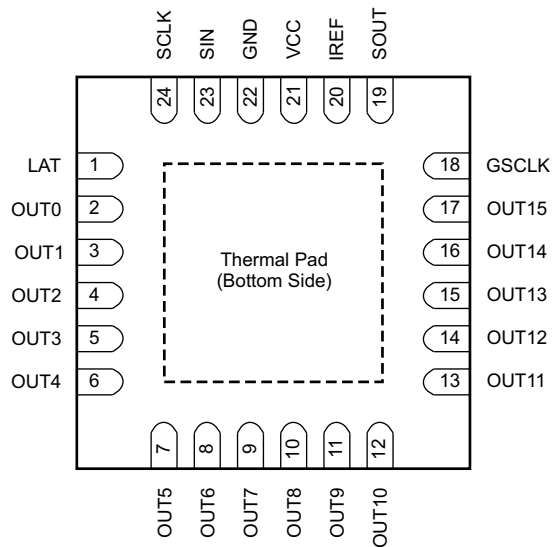

NOTE: The thermal pad is not internally connected to GND. The thermal pad must be connected to GND via the printed board circuit (PCB) pattern.

**PIN DESCRIPTIONS**

NAME	PIN NO.		I/O	DESCRIPTION
	DBQ	RGE		
	GND	1		
GSCLK	21	18	I	Grayscale (GS) pulse width modulation (PWM) reference clock control for OUT <sub>n</sub> . Each GSCLK rising edge increments the GS counter for PWM control. When the TMRST command is input with the TMRSTEN bit (equal to '1') in the function control data latch, all constant-current outputs (OUT0 to OUT15) are forced off and the GS counter is reset to '0'. Furthermore, all constant-current outputs are forced off and the GS counter is reset to '0' when the LATGS command is input with the XRFRESH bit (equal to '1') in the function control data latch.
IREF	23	20	I/O	Reference current terminal. A resistor connected between IREF to GND sets the maximum current for all constant-current outputs.
LAT	4	1	I	The LAT falling edge latches the data from the 16-bit common shift register into the first GS data latch for the OUT <sub>n</sub> that are selected by either the GS data address down counter, global brightness control (BC) data latch, or function control (FC) data latch. The data latch is selected by the number of input SCLK rising edges while LAT is high. This pin is internally pulled down to GND with a 500-kΩ (typ) resistor.
OUT0	5	2	O	Constant-current outputs. Multiple outputs can be configured in parallel to increase the constant-current capability. Different voltages can be applied to each output.
OUT1	6	3	O	
OUT2	7	4	O	
OUT3	8	5	O	
OUT4	9	6	O	
OUT5	10	7	O	
OUT6	11	8	O	
OUT7	12	9	O	
OUT8	13	10	O	
OUT9	14	11	O	
OUT10	15	12	O	
OUT11	16	13	O	
OUT12	17	14	O	
OUT13	18	15	O	
OUT14	19	16	O	
OUT15	20	17	O	
SCLK	3	24	I	Serial data shift clock. Data present on SIN are shifted to the LSB of the 16-bit common shift register with the SCLK rising edge. Data in the shift register are shifted towards the MSB at each SCLK rising edge. The MSB of the common shift register appears on SOUT.
SIN	2	23	I	Serial data input for the 16-bit common shift register
SOUT	22	19	O	Serial data output of the 16-bit common shift register. SOUT is connected to the 16-bit common shift register MSB. Data are clocked out at the SCLK rising edge. Data in the function data latch can be read from SOUT during the READFC command.
VCC	24	21	—	Power-supply voltage

### FUNCTIONAL BLOCK DIAGRAM

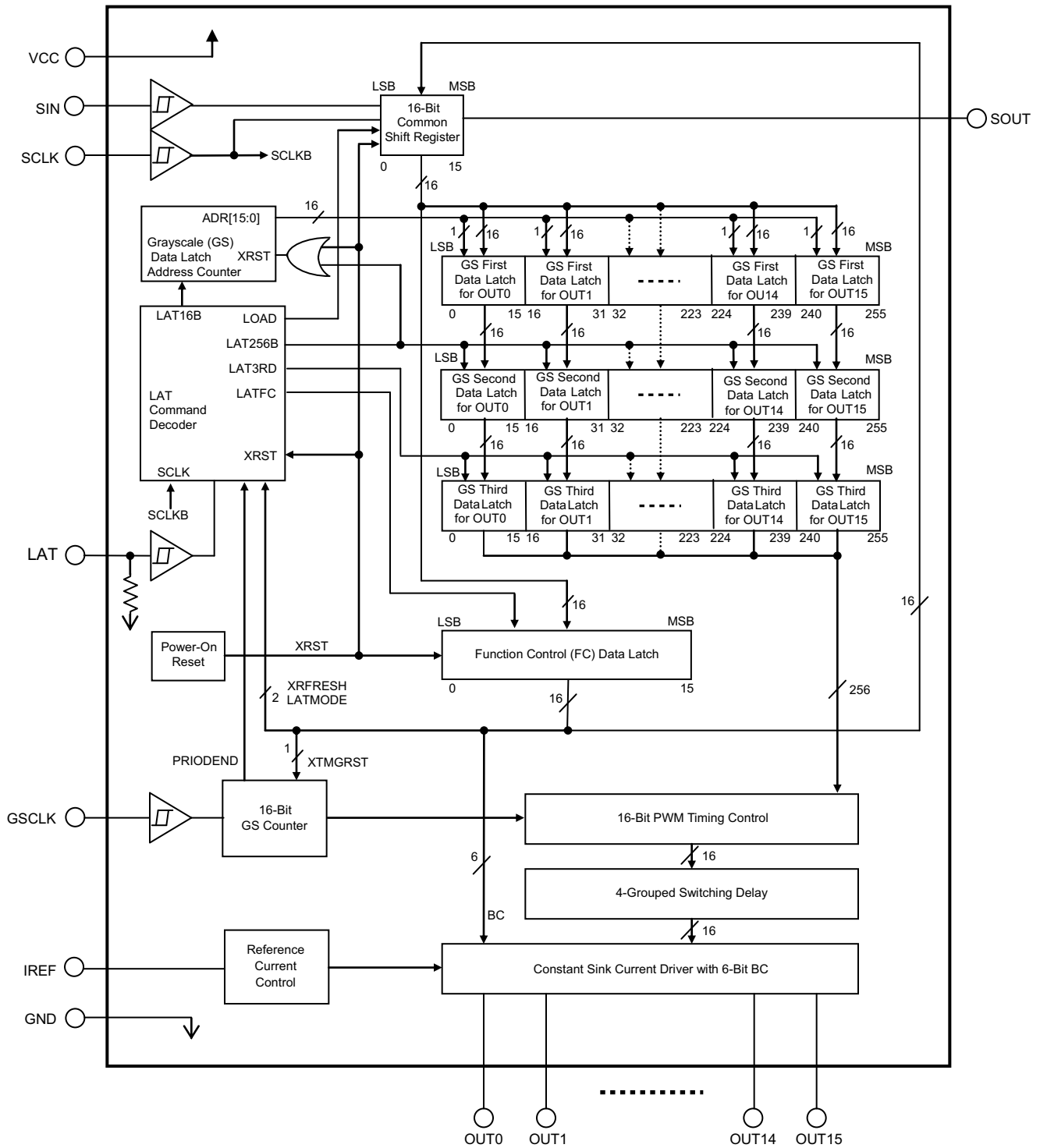

**TYPICAL CHARACTERISTICS**

At  $T_A = +25^\circ\text{C}$ , unless otherwise noted.

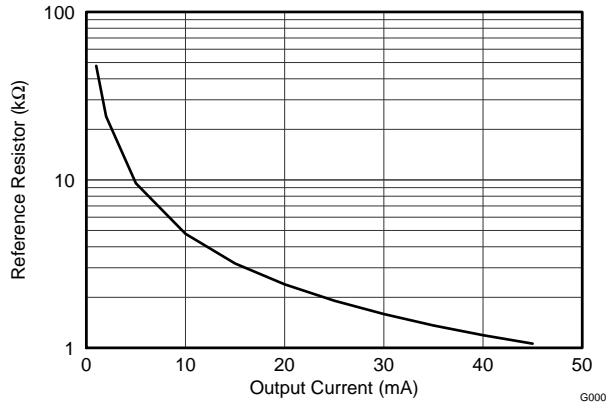

**Figure 11. REFERENCE RESISTOR vs OUTPUT CURRENT**

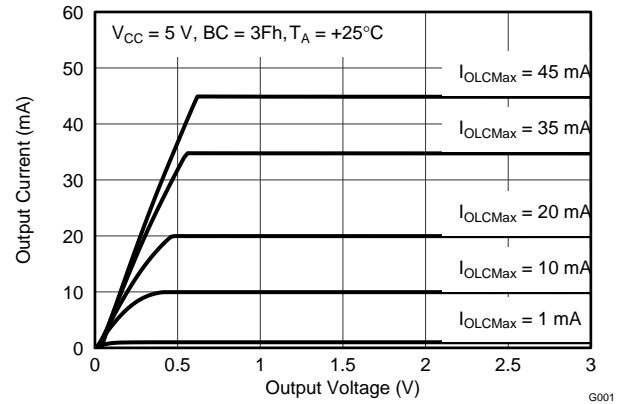

**Figure 12. OUTPUT CURRENT vs OUTPUT VOLTAGE**

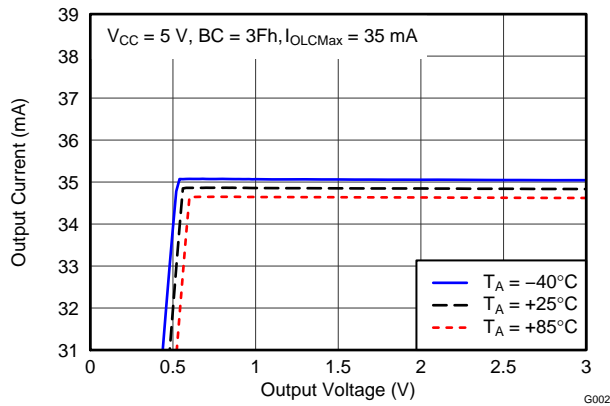

**Figure 13. OUTPUT CURRENT vs OUTPUT VOLTAGE**

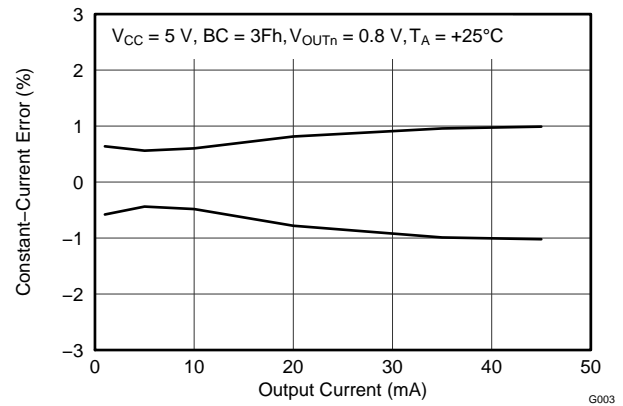

**Figure 14. CONSTANT-CURRENT ERROR vs OUTPUT CURRENT SET BY EXTERNAL RESISTOR**

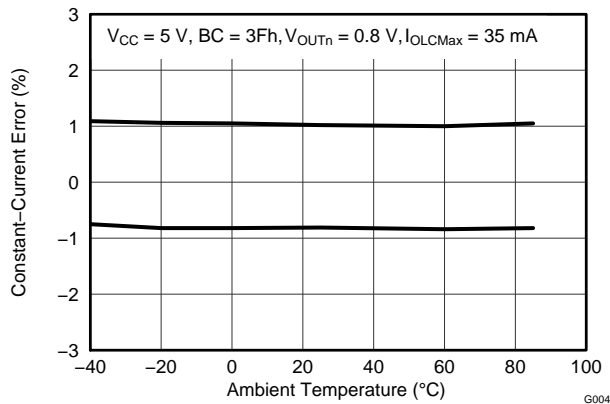

**Figure 15. CONSTANT-CURRENT ERROR vs AMBIENT TEMPERATURE**

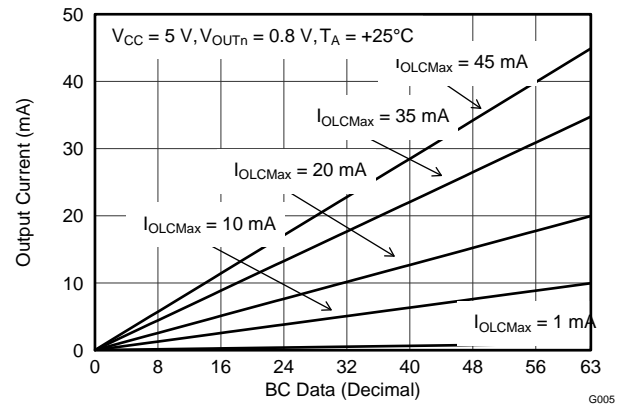

**Figure 16. GLOBAL BRIGHTNESS CONTROL LINEARITY**

**TYPICAL CHARACTERISTICS (continued)**

At  $T_A = +25^\circ\text{C}$ , unless otherwise noted.

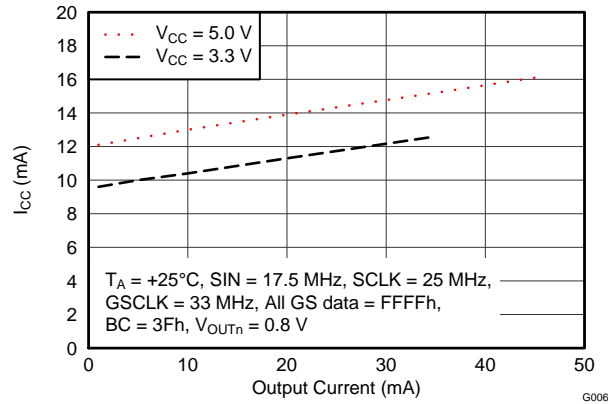

**Figure 17. SUPPLY CURRENT vs OUTPUT CURRENT**

## DETAILED DESCRIPTION

### MAXIMUM CONSTANT SINK CURRENT VALUE

The maximum output current value of each channel ( $I_{OLCMax}$ ) is programmed by a single resistor ( $R_{IREF}$ ) that is placed between the IREF and GND pins. The current value can be calculated by [Equation 1](#):

$$R_{IREF} \text{ (k}\Omega\text{)} = \frac{V_{IREF} \text{ (V)}}{I_{OLCMax} \text{ (mA)}} \times 39.8$$

Where:

$$\begin{aligned}
 V_{IREF} &= \text{the internal reference voltage on IREF (typically 1.20 V when the global BC data are at maximum)} \\
 I_{OLCMax} &= 1 \text{ mA to 35 mA (3 V} \leq V_{CC} \leq 3.6 \text{ V) or 1 mA to 45 mA (3.6 V} < V_{CC} \leq 5.5 \text{ V) at OUT}n \text{ and BC = } \\
 &63
 \end{aligned}
 \tag{1}$$

$I_{OLCMax}$  is the highest current for each output. Each output sinks  $I_{OLCMax}$  current when it is turned on and the global brightness control (BC) data are set to the maximum value of 3Fh (64). Each output sink current can be reduced by lowering the BC value.

$R_{IREF}$  must be between 1.06 k $\Omega$  and 47.8 k $\Omega$  in order to hold  $I_{OLCMax}$  between 45 mA (typ) and 1 mA (typ). Otherwise, the output may be unstable. Output currents lower than 1 mA can be achieved by setting  $I_{OLCMax}$  to 1 mA or higher and then using global BC to lower the output current.

[Table 1](#) shows the characteristics of the constant-current sink versus the external resistor,  $R_{IREF}$ .

**Table 1. Maximum Constant-Current Output versus External Resistor Value**

$I_{OLCMax}$ (mA)	$I_{OLC}$ FOLLOWING POWER-UP (mA, BC = 32)	$R_{IREF}$ (k $\Omega$ , typ)
45 ( $V_{CC} > 3.6$ V only)	22.5	1.06
40 ( $V_{CC} > 3.6$ V only)	20	1.19
35	17.5	1.37
30	15	1.59
25	12.5	1.91
20	10	2.39
15	7.5	3.18
10	5	4.78
5	2.5	9.55
1	0.5	47.8

### GLOBAL BRIGHTNESS CONTROL (BC) FUNCTION

The TLC59482 can simultaneously adjust the output current of all constant-current outputs. This function is called *global brightness control* (BC). The global BC for all outputs (OUT0 to OUT15) is programmed with a 6-bit word. The global BC adjusts all output currents in 64 steps from 0% to 100%, where 100% corresponds to the maximum output current set by  $R_{IREF}$ . [Equation 2](#) calculates the actual output current as a function of  $R_{IREF}$  and global BC value. BC data can be set via the serial interface. When the device is powered on, the BC data in the function control (FC) data latch is set to 32 as the initial value.

The output current value controlled by BC can be calculated by [Equation 2](#).

$$I_{OUTn} \text{ (mA)} = I_{OLCMax} \text{ (mA)} \times \frac{BCn}{63}$$

Where:

$$\begin{aligned}
 I_{OLCMax} &= \text{the maximum constant-current value for each output determined by } R_{IREF} \\
 BC &= \text{the global brightness control value in the brightness control data latch (0 to 63)}
 \end{aligned}
 \tag{2}$$

Table 2 summarizes the BC data versus the set current value.

**Table 2. BC Data versus Constant-Current Ratio and Set Current Value**

BC DATA			RATIO OF OUTPUT CURRENT TO $I_{OLCMax}(\%)$	$I_{OUT}$ (mA) ( $I_{OLCMax} = 45$ mA, typ)	$I_{OUT}$ (mA) ( $I_{OLCMax} = 1$ mA, typ)
BINARY	DECIMAL	HEX			
00 0000	0	00	0	0	0
00 0001	1	01	1.6	0.71	0.02
00 0010	2	02	3.2	1.43	0.03
—	—	—	—	—	—
01 1111	31	1F	49.2	22.14	0.49
10 0000 (default)	32 (default)	20 (default)	50.8	22.86	0.51
10 0001	33	21	52.4	23.57	0.52
—	—	—	—	—	—
11 1101	61	3D	96.8	43.57	0.97
11 1110	62	3E	98.4	44.29	0.98
11 1111	63	3F	100.0	45.00	1.00

### GRAYSCALE (GS) FUNCTION (PWM CONTROL)

The TLC59482 can adjust the brightness of each output channel using a pulse width modulation (PWM) control scheme. The architecture of 16 bits per channel results in 65,536 brightness steps, from 0% up to 100% brightness.

The PWM operation is controlled by the grayscale (GS) counter based on the GS data in the third GS data latch. The GS counter increments on each rising edge of the grayscale reference clock (GSCLK). When the TMGRST command is input with the TMRSTEN bit (equal to '1') of the function control data latch, or when the LATGS command is input with the XRFRESH bit (equal to '1') of the function control data latch, all constant-current outputs (OUT0 to OUT15) are forced off, the GS counter is reset to '0', and the GS PWM timing controller is initialized.

The on-time ( $t_{OUT\_ON}$ ) of each output (OUT $n$ ) can be calculated by [Equation 3](#).

$$t_{OUT\_ON} \text{ (ns)} = t_{GSCLK} \times GS_n$$

where:

$t_{GSCLK}$  is on GS clock period

$GS_n$  is the programmed GS value for OUT $n$  (0 to 65535)

(3)

Table 3 summarizes the GS data values versus the output on-time duty cycle in a 16-bit length PWM. When the device powers up, all outputs are forced off and do not turn on until the 256-bit GS data are written to the third data latch even if GSCLK is input.

**Table 3. Output Duty Cycle and On-Time versus GS Data (16-Bit PWM Bit Length)**

GS DATA		ON-TIME RATE vs MAX GS (%)	GS DATA		ON-TIME RATE vs MAX GS (%)
DECIMAL	HEX		DECIMAL	HEX	
0	0	0	32768	8000	50.001
1	1	0.002	32769	8001	50.002
2	2	0.003	32770	8002	50.004
3	3	0.005	32771	8003	50.005
—	—	—	—	—	—
8191	1FFF	12.499	40959	9FFF	62.499
8192	2000	12.500	40960	A000	62.501
8193	2001	12.502	40961	A001	62.502
—	—	—	—	—	—
16383	3FFF	24.999	49151	BFFF	75.000
16384	4000	25.000	49152	C000	75.001
16385	4001	25.002	49153	C001	75.003
—	—	—	—	—	—
24575	5FFF	37.499	57343	DFFF	87.500
24576	6000	37.501	57344	E000	87.501
24577	6001	37.502	57345	E001	87.503
—	—	—	—	—	—
32765	7FFD	49.996	65533	FFFD	99.997
32766	7FFE	49.998	65534	FFFE	99.998
32767	7FFF	49.999	65535	FFFF	100.000

### Enhanced Spectrum (ES) PWM Control

In this PWM control, the entire display period is divided into 128 display segments. The total display period is the time from the first grayscale clock (GSCLK) to the 65,536th GS clock input for the 16-bit length PWM. Each display segment has a maximum of 512 grayscale clocks (maximum). The  $OUT_n$  on-time changes, depending on the 16-bit grayscale data. Refer to Table 4 for the sequence of information and to Figure 18 for the timing information.

**Table 4. ES PWM Drive Turn On-Time Length**

GS DATA		OUT <sub>n</sub> DRIVER OPERATION
DECIMAL	HEX	
0	0000h	Does not turn on
1	0001h	Turns on for one GSCLK period in the first display segment
2	0002h	Turns on for one GSCLK period in the first and 65th display segments
3	0003h	Turns on for one GSCLK period in the first, 65th, and 33th display segments
4	0004h	Turns on for one GSCLK period in the first, 65th, 33th, and 97th display segments
5	0005h	Turns on for one GSCLK period in the first, 65th, 33th, 97th, and 17th display segments
6	0006h	Turns on for one GSCLK period in the first, 65th, 33th, 97th, 17th, and 81th display segments
—	—	The number of display segments where OUT <sub>n</sub> is turned on for one GSCLK is incremented by increasing the GS data in the following order: 1 > 65 > 33 > 97 > 17 > 81 > 49 > 113 > 9 > 73 > 41 > 105 > 25 > 89 > 57 > 121 > 5 > 69 > 37 > 101 > 21 > 85 > 53 > 117 > 13 > 77 > 45 > 109 > 29 > 93 > 61 > 125 > 3 > 67 > 35 > 99 > 19 > 83 > 51 > 115 > 11 > 75 > 43 > 107 > 27 > 91 > 59 > 123 > 7 > 71 > 39 > 103 > 23 > 87 > 55 > 119 > 15 > 79 > 47 > 111 > 31 > 95 > 63 > 127 > 2 > 66 > 34 > 98 > 18 > 82 > 50 > 114 > 10 > 74 > 42 > 106 > 26 > 90 > 58 > 122 > 6 > 70 > 38 > 102 > 22 > 86 > 54 > 118 > 14 > 78 > 46 > 110 > 30 > 94 > 62 > 126 > 4 > 68 > 36 > 100 > 20 > 84 > 52 > 116 > 12 > 76 > 44 > 108 > 28 > 92 > 60 > 124 > 8 > 72 > 40 > 104 > 24 > 88 > 56 > 120 > 16 > 80 > 48 > 112 > 32 > 96 > 64 > 128.
127	007Fh	Turns on for one GSCLK period in the first to 127th display segments, but does not turn on in the 128th display segment
128	0080h	Turns on for one GSCLK period in all display segments (first to 128th)
129	0081h	Turns on for two GSCLK periods in the first display period and for one GSCLK period in all other display periods
—	—	The number of display segments where OUT <sub>n</sub> is turned on for one GSCLK is incremented by increasing the GS data in the following order: 1 > 65 > 33 > 97 > 17 > 81 > 49 > 113 > 9 > 73 > 41 > 105 > 25 > 89 > 57 > 121 > 5 > 69 > 37 > 101 > 21 > 85 > 53 > 117 > 13 > 77 > 45 > 109 > 29 > 93 > 61 > 125 > 3 > 67 > 35 > 99 > 19 > 83 > 51 > 115 > 11 > 75 > 43 > 107 > 27 > 91 > 59 > 123 > 7 > 71 > 39 > 103 > 23 > 87 > 55 > 119 > 15 > 79 > 47 > 111 > 31 > 95 > 63 > 127 > 2 > 66 > 34 > 98 > 18 > 82 > 50 > 114 > 10 > 74 > 42 > 106 > 26 > 90 > 58 > 122 > 6 > 70 > 38 > 102 > 22 > 86 > 54 > 118 > 14 > 78 > 46 > 110 > 30 > 94 > 62 > 126 > 4 > 68 > 36 > 100 > 20 > 84 > 52 > 116 > 12 > 76 > 44 > 108 > 28 > 92 > 60 > 124 > 8 > 72 > 40 > 104 > 24 > 88 > 56 > 120 > 16 > 80 > 48 > 112 > 32 > 96 > 64 > 128.
255	00FFh	Turns on for two GSCLK periods in the first to 127th display segments and turns on one GSCLK period in the 128th display segment
256	0100h	Turns on for two GSCLK periods in all display segments (first to 128th)
257	0101h	Turns on for three GSCLK periods in the first display segments and for two GSCLK periods in all other display segments
—	—	The number of display segments where OUT <sub>n</sub> is turned on for one GSCLK is incremented by increasing the GS data in the following order: 1 > 65 > 33 > 97 > 17 > 81 > 49 > 113 > 9 > 73 > 41 > 105 > 25 > 89 > 57 > 121 > 5 > 69 > 37 > 101 > 21 > 85 > 53 > 117 > 13 > 77 > 45 > 109 > 29 > 93 > 61 > 125 > 3 > 67 > 35 > 99 > 19 > 83 > 51 > 115 > 11 > 75 > 43 > 107 > 27 > 91 > 59 > 123 > 7 > 71 > 39 > 103 > 23 > 87 > 55 > 119 > 15 > 79 > 47 > 111 > 31 > 95 > 63 > 127 > 2 > 66 > 34 > 98 > 18 > 82 > 50 > 114 > 10 > 74 > 42 > 106 > 26 > 90 > 58 > 122 > 6 > 70 > 38 > 102 > 22 > 86 > 54 > 118 > 14 > 78 > 46 > 110 > 30 > 94 > 62 > 126 > 4 > 68 > 36 > 100 > 20 > 84 > 52 > 116 > 12 > 76 > 44 > 108 > 28 > 92 > 60 > 124 > 8 > 72 > 40 > 104 > 24 > 88 > 56 > 120 > 16 > 80 > 48 > 112 > 32 > 96 > 64 > 128.
65407	FF7Fh	Turns on for 511 GSCLK periods in the first to 127th display segments, but only turns on 510 GSCLK periods in the 128th display segment
65408	FF80h	Turns on for 511 GSCLK periods in all display segments (first to 128th)
65409	FF81h	Turns on for 512 GSCLK periods in the first display period and for 511 GSCLK periods in the second to 128th display segments
—	—	—
65534	FFFEh	Turns on for 512 GSCLK periods in the first to 63th and 65th to 127th display segments; also turns on 511 GSCLK periods in 64th and 128th display segments
65535	FFFFh	Turns on for 512 GSCLK periods in the first to 127th display segments but only turns on 511 GSCLK periods in the 128th display segment

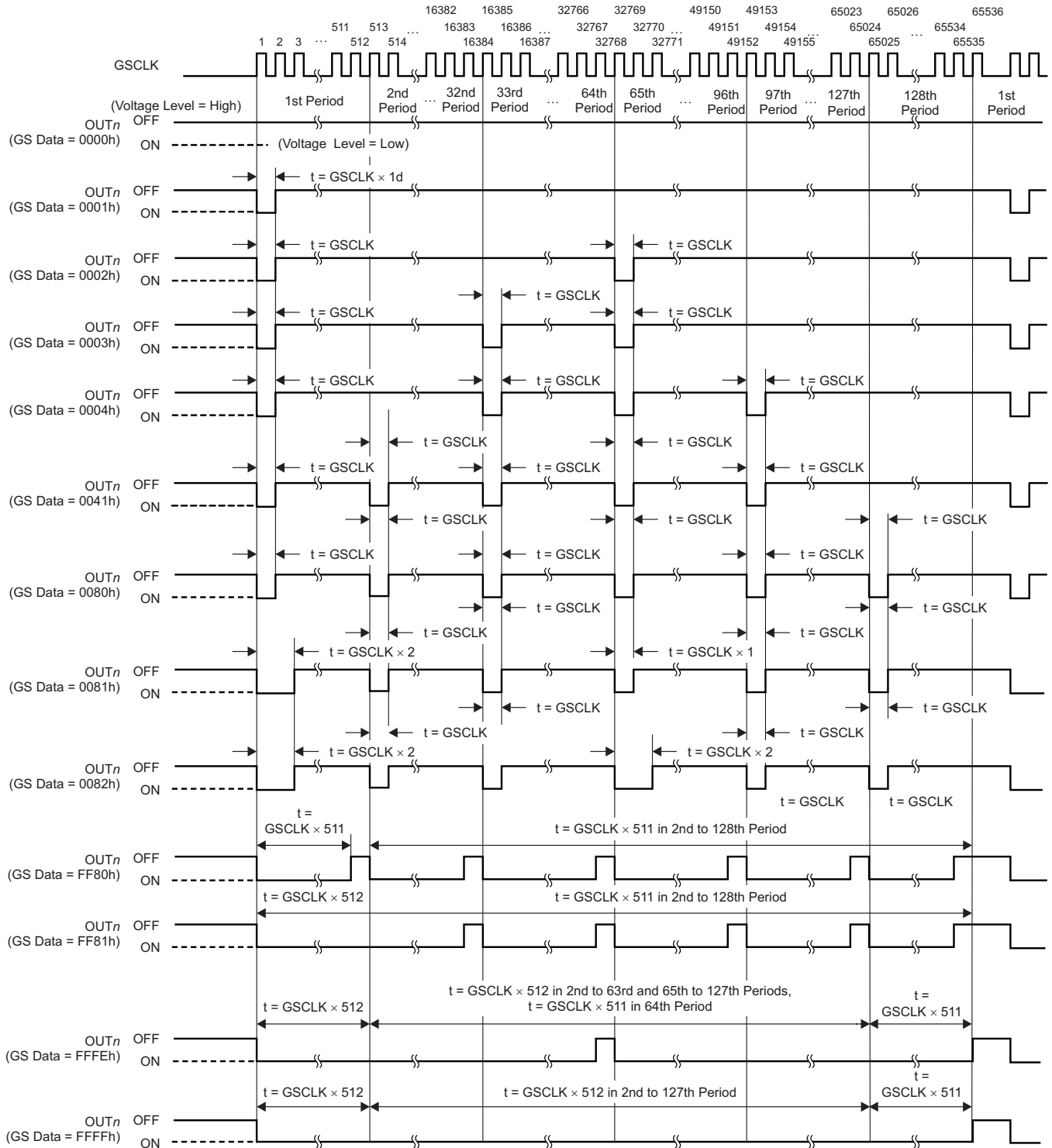

Figure 18. ES PWM Operation

### Auto Display Repeat Function

This function can repeat the total display period as long as GSCLK is present, as shown in Figure 19. This function is always enabled. OUT<sub>n</sub> turn on at the 513<sup>th</sup> GSCLK after the first LATGS command is input.

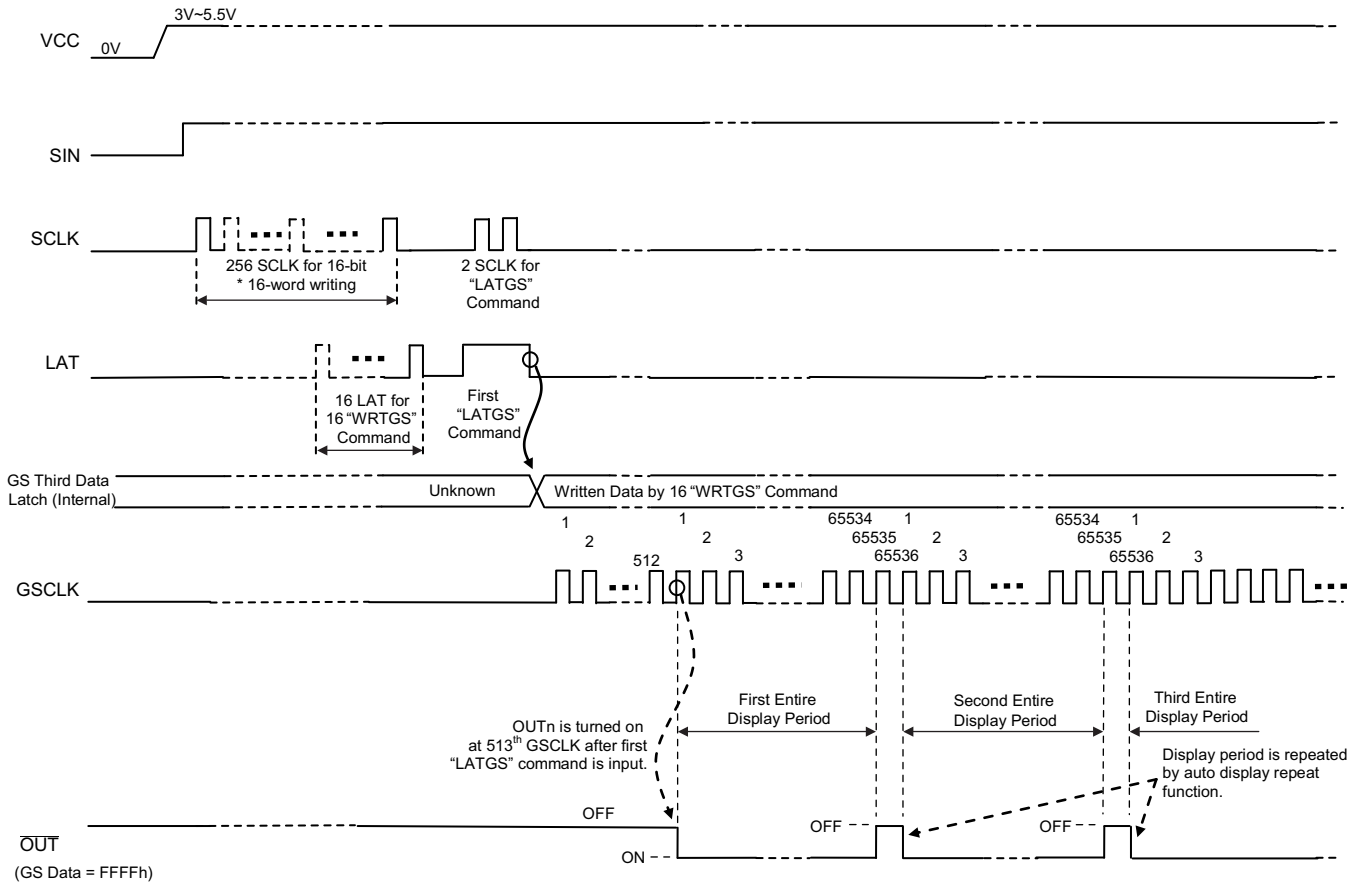

Figure 19. Auto Display Repeat Function

### Auto Data Refresh Function

This function allows users to input grayscale (GS) data at any time without synchronizing the input to the display timing. When the LATGS command is input with the auto data refresh function enabled (XRFRESH bit = 0), the 256-bit data in the first GS data latch are copied only to the second GS data latch. The data in the second GS data latch are copied to the third data latch when the 65,536<sup>th</sup> GSCLK occurs. The third latch data are used for constant-current output (OUT<sub>0</sub>-OUT<sub>15</sub>) for the next display period.

When the LATGS command is input with the auto data refresh function disabled (XRFRESH bit = 1), the 256-bit data in the first GS data latch are copied to the second and third GS data latches at the same time and the GS data in the third data latch are used for OUT<sub>0</sub>-OUT<sub>15</sub> on/off control from the next input GSCLK rising edge. Furthermore, the GS counter is set to '0' and all constant-current outputs (OUT<sub>n</sub>) are forced off. Refer to Figure 20 for a timing diagram of the auto data refresh function.

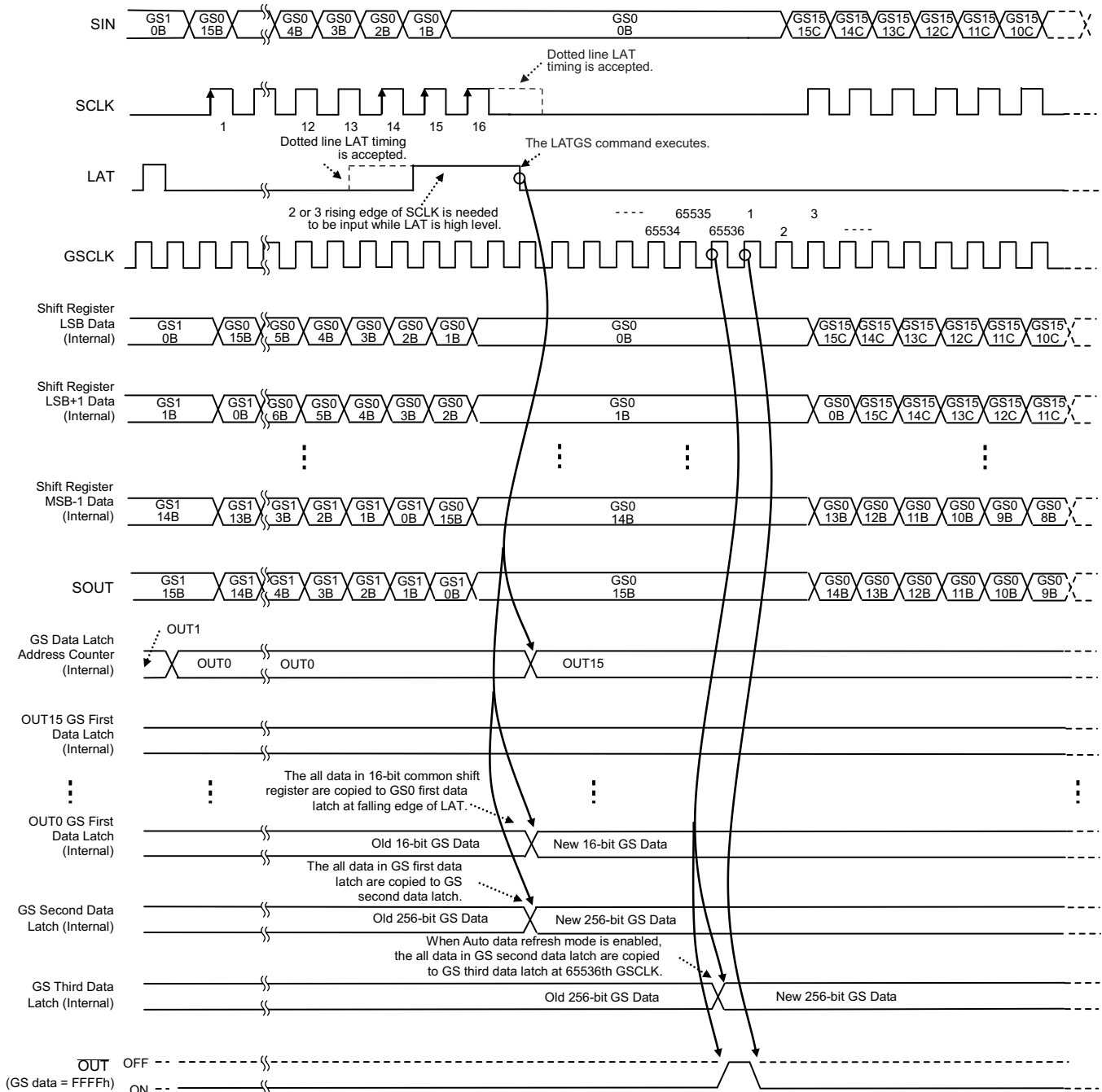

Figure 20. Auto Data Refresh Function (XRFRESH = 0, LATMODE = 0)

### REGISTER AND DATA LATCH CONFIGURATION

The TLC59482 has one common shift register, one function control (FC) data latch, and a set of three data latches: the first, second, and third grayscale (GS) data latches. The common shift register and FC data latch are 16 bits long and the GS data latches are 256 bits long. Figure 21 shows the common shift register and the data latches configuration.

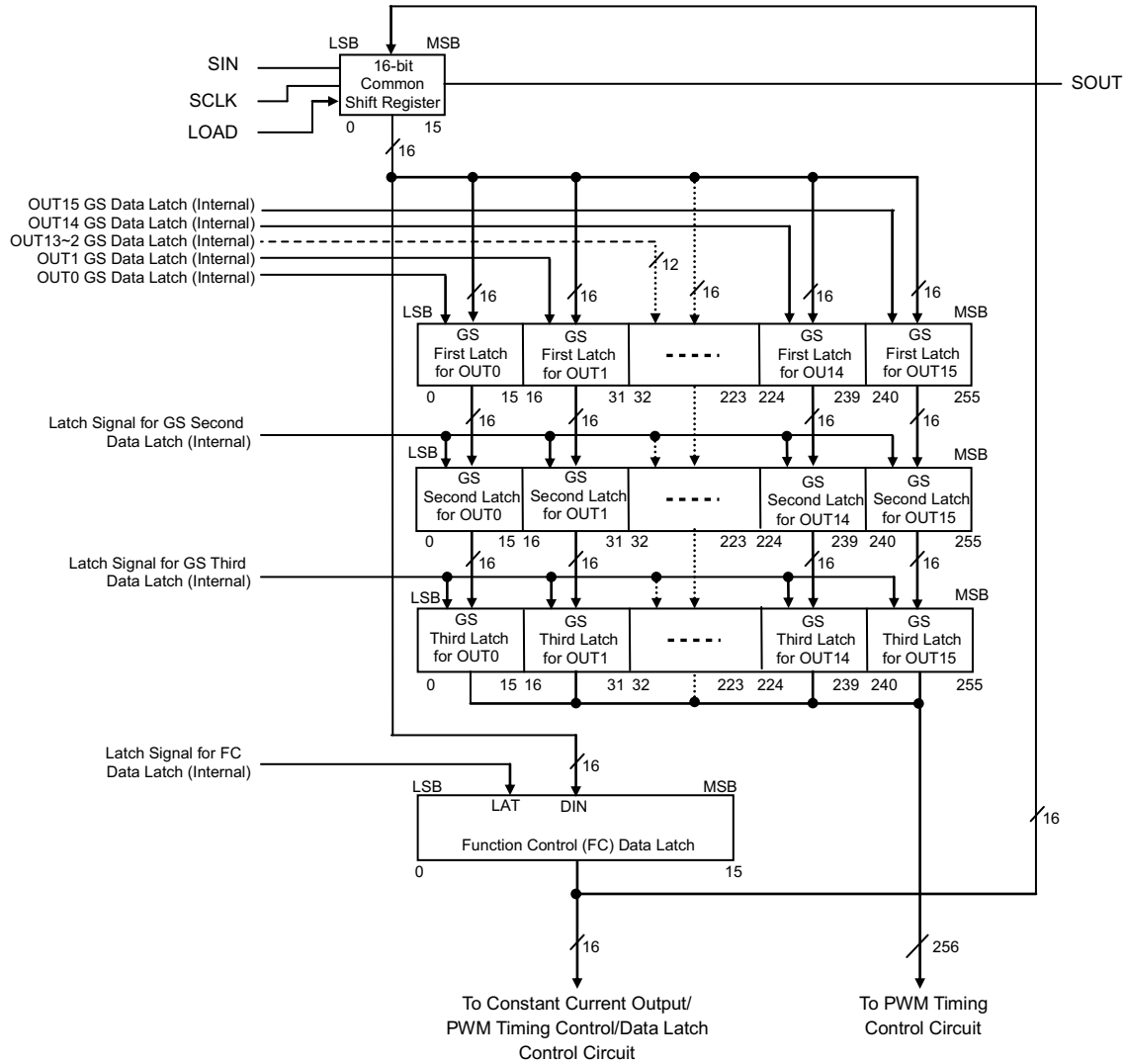

Figure 21. Shift Register and Data Latch Configuration

### 16-Bit Common Shift Register

The 16-bit common shift register is used to shift data from the SIN pin into the TLC59482. The data shifted into the register are used for GS and FC data. The LSB of the common shift register is connected to SIN and the MSB is connected to SOUT. On each SCLK rising edge, the data on SIN are shifted into the LSB and all 16 bits are shifted towards the MSB. The register MSB is always connected to SOUT. When the device is powered up, the data in the 16-bit common shift register are set to '0'.

### First, Second, and Third Grayscale Data Latch

The first, second, and third grayscale (GS) data latches are each 256 bits long, and set the PWM timing for each constant-current output. The on-time of all constant-current outputs is controlled by the data in the third GS data latch. The 16-bit data are copied to the first GS data latch indicated by the GS data latch address counter when the WRTGS command is input. The 256-bit GS data for OUT<sub>n</sub> in the first data latch are copied to the second GS data latch when the LATGS command is input. The 256-bit data in the second data latch are copied to the third GS data latch when the 65,536th GSCLK occurs with the XRFRESH bit in the FC data latch set to '0'. When the XRFRESH bit is '1', the 256-bit data in the first data latch are copied to the second and third data latch at the same time. When the device powers up, all constant-current outputs are forced off until GS data are written to the third data latch. The GS data write sequence is shown in Figure 22 and Figure 23.

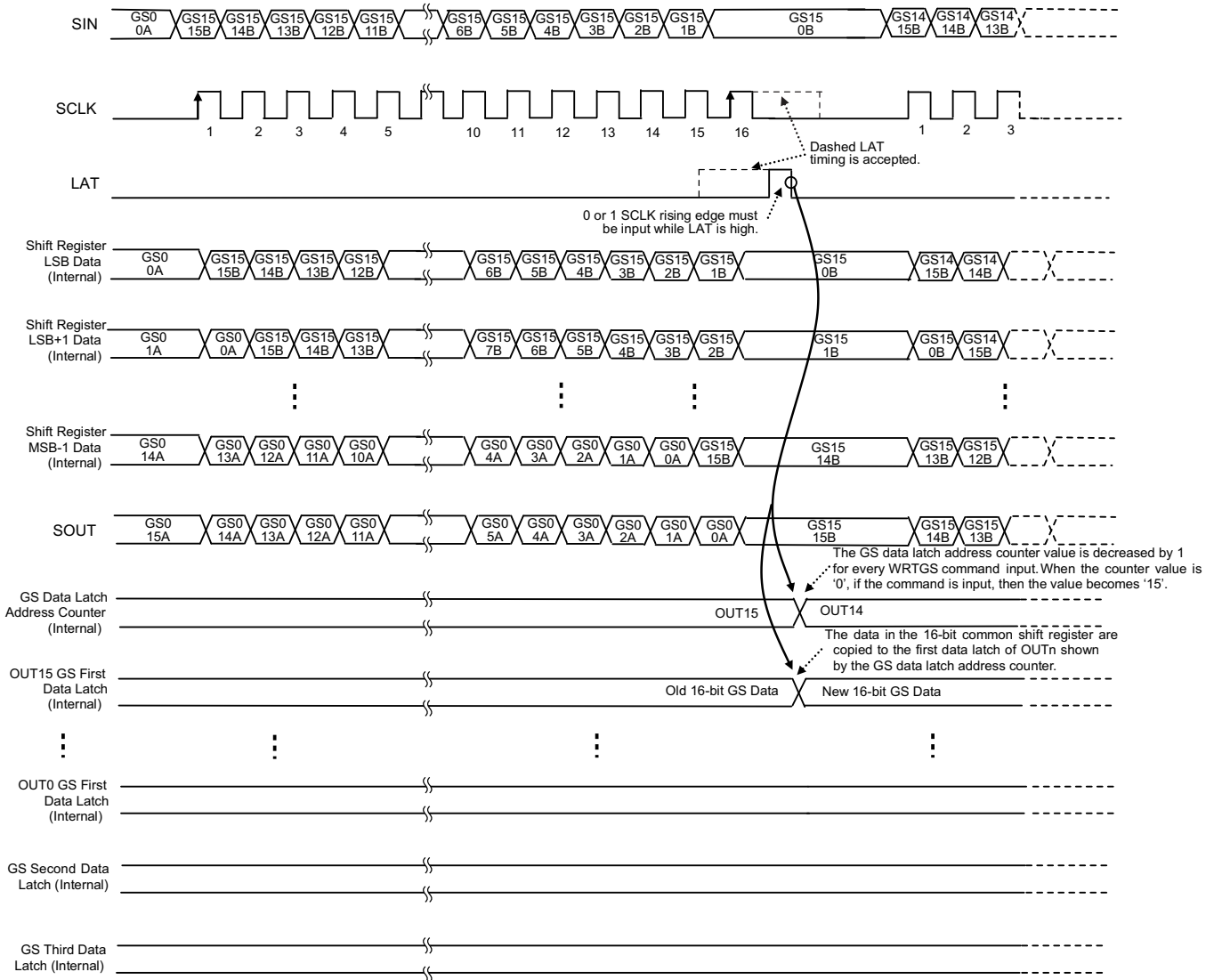

Figure 22. 16-Bit GS Data Write (WRTGS) Command

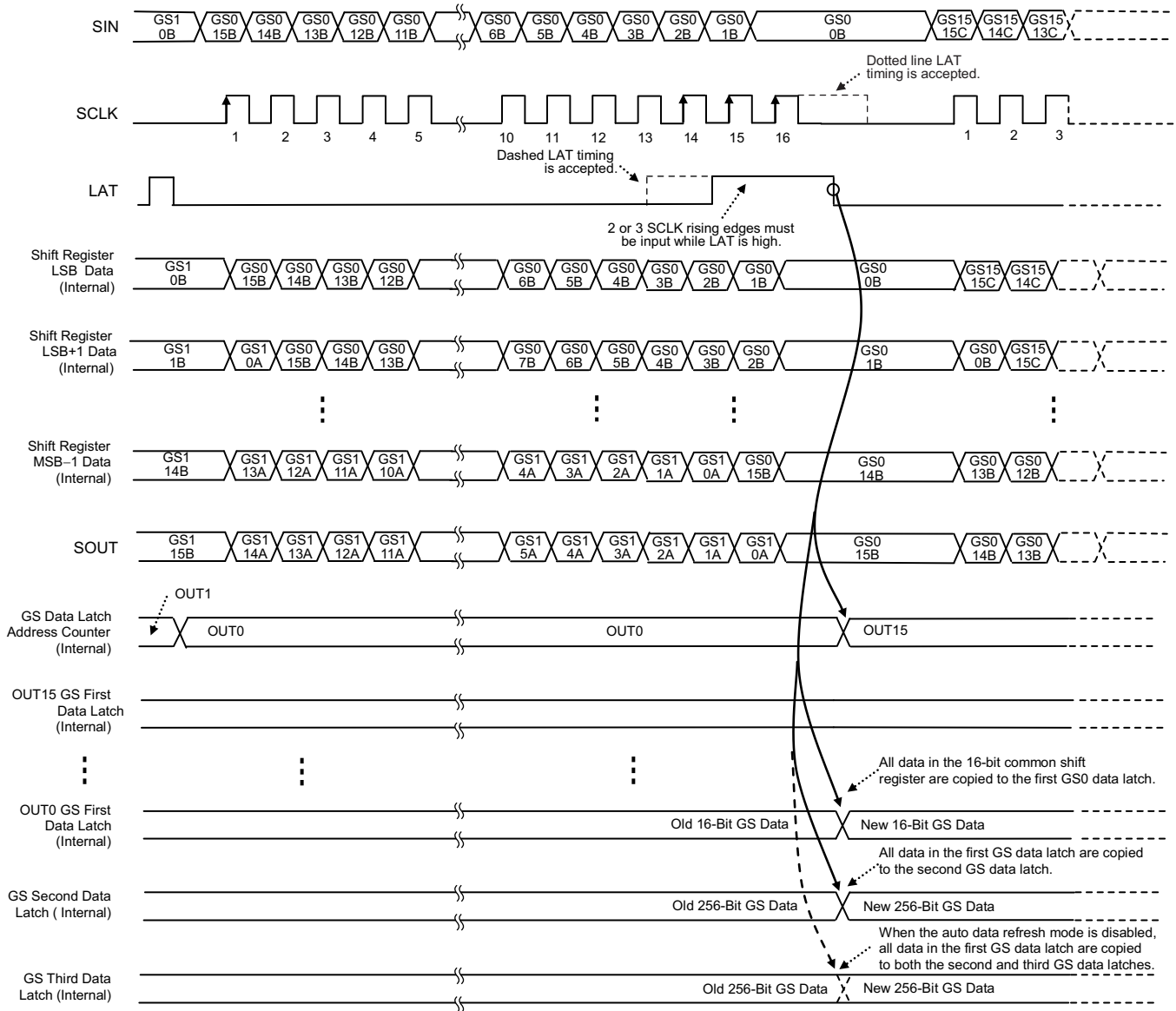

Figure 23. 256-Bit GS Data Latch (LATGS) Command (LATMODE = 0)

## Function Control (FC) Data Latch

The function control (FC) data latch is 16 bits long. This latch sets the brightness control (BC) data, auto data refresh, enables or disables the display timing reset, and selects the data latch mode. When the device is powered on, the data in the FC data latch are set to the default values, as shown in [Table 5](#).

**Table 5. Function Control Data Latch Bit Description**

BIT NUMBER	BIT NAME	DEFAULT VALUE (Binary)	DESCRIPTION
0 (LSB) to 3	N/A	0000	No applicable bit
4-9	BC	100000	Global brightness (BC) control bit (000000-111111). This 6-bit data controls all output current with 64 steps between 0% and 100% of the maximum current determined by a external resistor. When all bits are '0', all outputs are off. When the device is powered on, all output current are set to approximately 50%.
10	XRFRESH	0	Auto data refresh mode bit (0 = enabled, 1 = disabled). If the LATGS command is input while this bit is '1', all data in the first grayscale (GS) data latch are copied to both the second and third GS data latches. All OUT <sub>n</sub> are forced off and the GS counter is also reset to '0'. If the LATGS command is input while this bit is '0', all data in the first GS data latch are only copied to the second GS data latch. All data in the second GS data latch are copied to the third GS data latch when the GS counter reaches the maximum count value of 65,535. No OUT <sub>n</sub> are forced off and the GS counter continues counting.
11	TMRSTEN	0	Display timing reset enable bit (0 = disabled, 1 = enabled). If the TMGRST command is input while this bit is '1', the GS counter is reset to '0'. When this occurs, all OUT <sub>n</sub> are forced off. When this bit is '0', even if the TMGRST command is input, the GS counter is not reset to '0'.
12-14	N/A	000	No applicable bit
15 (MSB)	LATMODE	0	Latch mode select bit (0 = 15 WRTGS + 1 LATGS mode, 1 = 16 WRTGS + 1 LATGS mode). When this bit is '1', The commands for all GS data writes are (16 × WRTGS + 1 LATGS). The 16th WRTGS command is required to latch the last GS input 16-bit data to the first GS data latch. When this bit is '0', the commands for all GS data writes are (15 × WRTGS + 1 LATGS). The 16th WRTGS command is not required to latch the last GS input 16-bit data to the first GS data latch.

### Display Timing Reset Function

This function allows users to reset the GS counter using the TMGRST command described in [Table 6](#). This function is enabled when the TMRSTEN bit in the FC control data latch is '1'. The grayscale counter is reset to '0' when the TMGRST command is input. All OUT<sub>n</sub> are forced off. Refer to [Figure 26](#) for a display timing reset functional timing diagram

**Table 6. Function Commands Description**

COMMAND NAME	SCLK RISING EDGES WHILE LAT IS HIGH	DESCRIPTION
WRTGS (16-bit GS data write)	0 or 1	The 16-bit data in the 16-bit common shift register are copied to the 16-bit GS latch in the first latch selected by the GS data latch address counter. Refer to <a href="#">Figure 22</a> for a timing diagram of this command operation.
LATGS (256-bit GS data latch)	2 or 3	All data in the first GS data latch are only copied to the second GS data latch when the XRFRESH bit in the FC data latch is '0'. All data in the first GS data latch are copied to both the second and third GS data latches when the XRFRESH bit in the FC data latch is '1'. The GS data latch address counter is initialized to OUT15 at the same timing. Refer to <a href="#">Figure 23</a> for a timing diagram of this command operation.
READFC (FC data read)	4 or 5	The 16-bit data in the FC data latch are copied to the 16-bit shift register. The loaded data can be read from SOUT synchronized with the SCLK rising edge. Refer to <a href="#">Figure 24</a> for a timing diagram of this command operation.
WRTFC (FC data write)	10 or 11	The 16-bit data in the 16-bit common shift register are copied to the FC data latch. Refer to <a href="#">Figure 25</a> for a timing diagram of this command operation.
TMGRST (display timing reset)	12 or 13	The GS counter is reset to '0' and all constant-current outputs (OUT <sub>n</sub> ) are forced off when the TMRSTEN bit in the FC data latch is '1'. However, the GS data in the third data latch are not updated. Refer to <a href="#">Figure 26</a> for a timing diagram of this command operation.
FCWRTEN (FC write enable)	14 or 15	FC writes are enabled by this command. This command must always be input before the FC data write occurs. Refer to <a href="#">Figure 25</a> for a timing diagram of this command operation.

### Function Commands

The TLC59482 has six commands that can be input with SCLK and LAT signals: WRTGS, LATGS, READFC, WRTFC, TMGRST, and FCWRTEN. Refer to [Figure 21](#) to [Figure 26](#) for detailed command input timing diagrams for each command. Each command function is described in [Table 6](#).

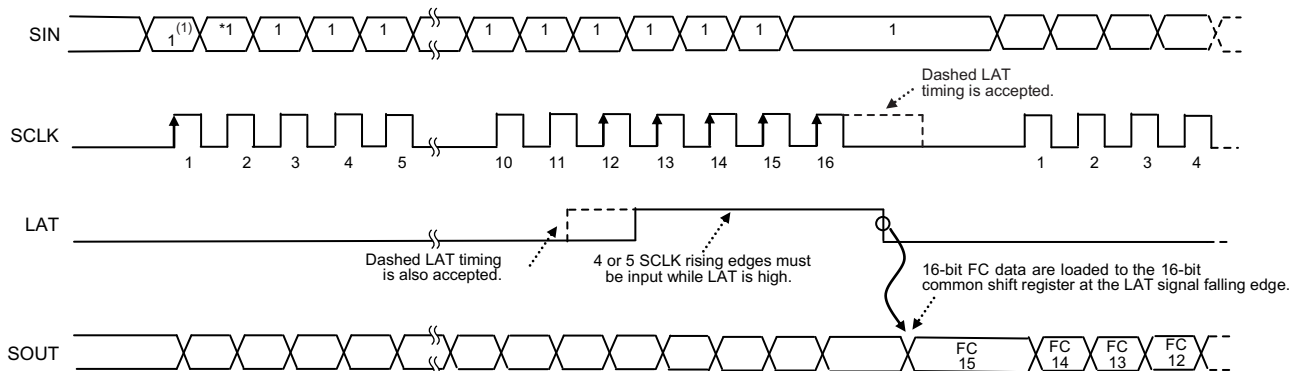

**Figure 24. FC Data Read (READFC) Command Timing Diagram**

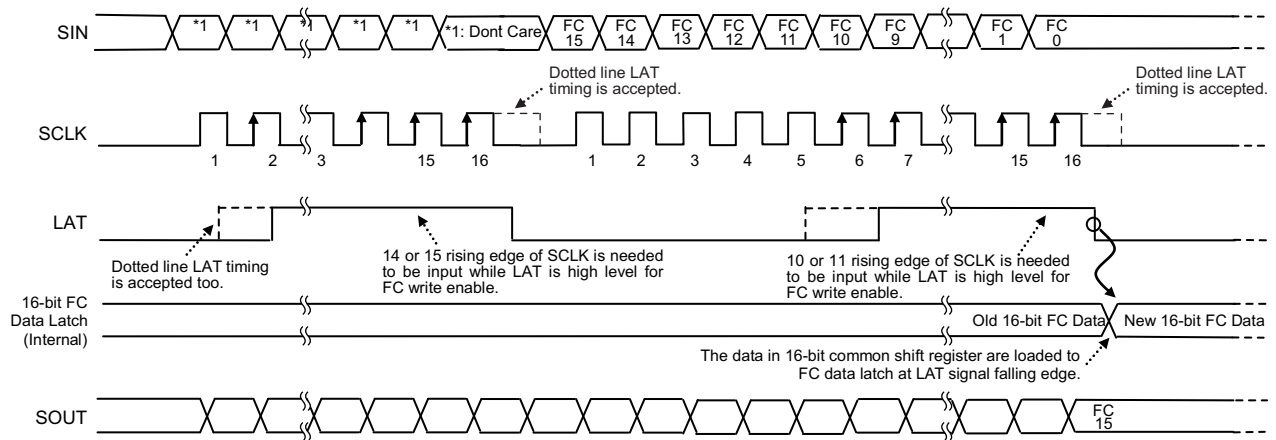

Figure 25. FC Data Write Enable (FCWRTE) and FC Data Write (WRTFC) Command Timing Diagram

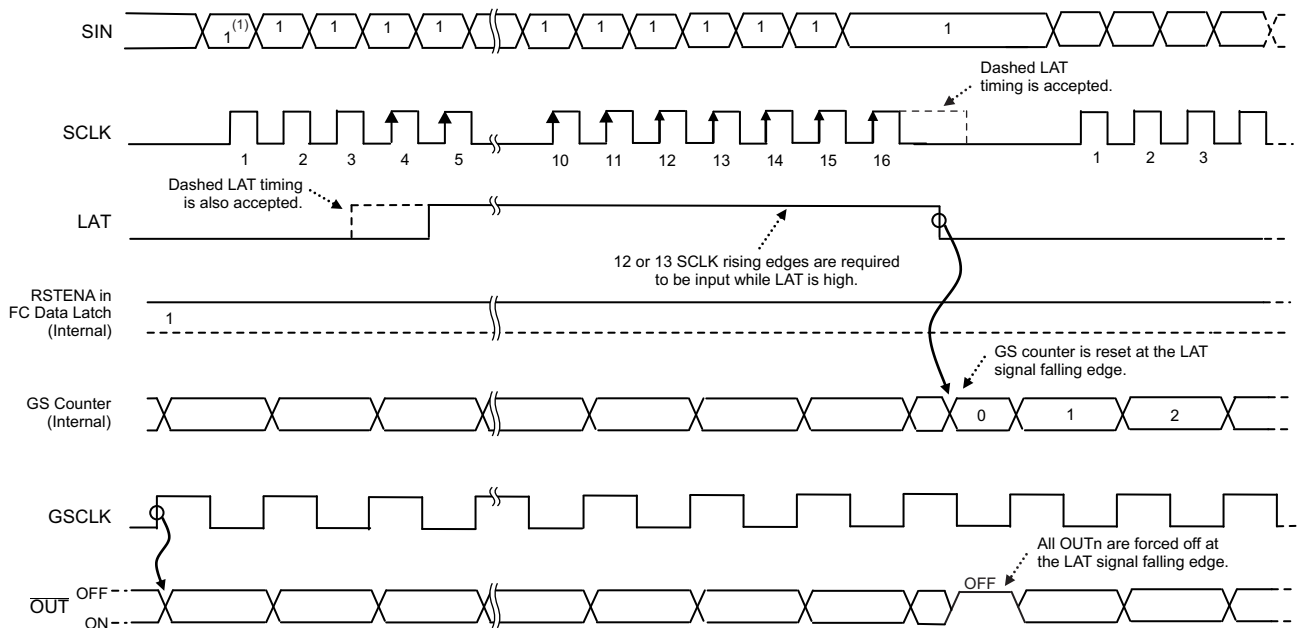

Figure 26. Display Timing Reset (TMGRST) Command Timing Diagram





**PACKAGING INFORMATION**

Orderable Device	Status (1)	Package Type	Package Drawing	Pins	Package Qty	Eco Plan (2)	Lead/Ball Finish	MSL Peak Temp (3)	Op Temp (°C)	Top-Side Markings (4)	Samples
TLC59482DBQ	ACTIVE	SSOP	DBQ	24	50	Green (RoHS & no Sb/Br)	CU NIPDAU	Level-2-260C-1 YEAR	-40 to 85	TLC59482	<a href="#">Samples</a>
TLC59482DBQR	ACTIVE	SSOP	DBQ	24	2500	Green (RoHS & no Sb/Br)	CU NIPDAU	Level-2-260C-1 YEAR	-40 to 85	TLC59482	<a href="#">Samples</a>

(1) The marketing status values are defined as follows:

**ACTIVE:** Product device recommended for new designs.

**LIFEBUY:** TI has announced that the device will be discontinued, and a lifetime-buy period is in effect.

**NRND:** Not recommended for new designs. Device is in production to support existing customers, but TI does not recommend using this part in a new design.

**PREVIEW:** Device has been announced but is not in production. Samples may or may not be available.

**OBSOLETE:** TI has discontinued the production of the device.

(2) Eco Plan - The planned eco-friendly classification: Pb-Free (RoHS), Pb-Free (RoHS Exempt), or Green (RoHS & no Sb/Br) - please check <http://www.ti.com/productcontent> for the latest availability information and additional product content details.

**TBD:** The Pb-Free/Green conversion plan has not been defined.

**Pb-Free (RoHS):** TI's terms "Lead-Free" or "Pb-Free" mean semiconductor products that are compatible with the current RoHS requirements for all 6 substances, including the requirement that lead not exceed 0.1% by weight in homogeneous materials. Where designed to be soldered at high temperatures, TI Pb-Free products are suitable for use in specified lead-free processes.

**Pb-Free (RoHS Exempt):** This component has a RoHS exemption for either 1) lead-based flip-chip solder bumps used between the die and package, or 2) lead-based die adhesive used between the die and leadframe. The component is otherwise considered Pb-Free (RoHS compatible) as defined above.

**Green (RoHS & no Sb/Br):** TI defines "Green" to mean Pb-Free (RoHS compatible), and free of Bromine (Br) and Antimony (Sb) based flame retardants (Br or Sb do not exceed 0.1% by weight in homogeneous material)

(3) MSL, Peak Temp. -- The Moisture Sensitivity Level rating according to the JEDEC industry standard classifications, and peak solder temperature.

(4) Multiple Top-Side Markings will be inside parentheses. Only one Top-Side Marking contained in parentheses and separated by a "~" will appear on a device. If a line is indented then it is a continuation of the previous line and the two combined represent the entire Top-Side Marking for that device.

**Important Information and Disclaimer:** The information provided on this page represents TI's knowledge and belief as of the date that it is provided. TI bases its knowledge and belief on information provided by third parties, and makes no representation or warranty as to the accuracy of such information. Efforts are underway to better integrate information from third parties. TI has taken and continues to take reasonable steps to provide representative and accurate information but may not have conducted destructive testing or chemical analysis on incoming materials and chemicals. TI and TI suppliers consider certain information to be proprietary, and thus CAS numbers and other limited information may not be available for release.

In no event shall TI's liability arising out of such information exceed the total purchase price of the TI part(s) at issue in this document sold by TI to Customer on an annual basis.

**TAPE AND REEL INFORMATION**

**QUADRANT ASSIGNMENTS FOR PIN 1 ORIENTATION IN TAPE**

\*All dimensions are nominal

Device	Package Type	Package Drawing	Pins	SPQ	Reel Diameter (mm)	Reel Width W1 (mm)	A0 (mm)	B0 (mm)	K0 (mm)	P1 (mm)	W (mm)	Pin1 Quadrant
TLC59482DBQR	SSOP	DBQ	24	2500	330.0	16.4	6.5	9.0	2.1	8.0	16.0	Q1

TAPE AND REEL BOX DIMENSIONS



\*All dimensions are nominal

Device	Package Type	Package Drawing	Pins	SPQ	Length (mm)	Width (mm)	Height (mm)
TLC59482DBQR	SSOP	DBQ	24	2500	367.0	367.0	38.0



## IMPORTANT NOTICE

Texas Instruments Incorporated and its subsidiaries (TI) reserve the right to make corrections, enhancements, improvements and other changes to its semiconductor products and services per JESD46, latest issue, and to discontinue any product or service per JESD48, latest issue. Buyers should obtain the latest relevant information before placing orders and should verify that such information is current and complete. All semiconductor products (also referred to herein as "components") are sold subject to TI's terms and conditions of sale supplied at the time of order acknowledgment.

TI warrants performance of its components to the specifications applicable at the time of sale, in accordance with the warranty in TI's terms and conditions of sale of semiconductor products. Testing and other quality control techniques are used to the extent TI deems necessary to support this warranty. Except where mandated by applicable law, testing of all parameters of each component is not necessarily performed.

TI assumes no liability for applications assistance or the design of Buyers' products. Buyers are responsible for their products and applications using TI components. To minimize the risks associated with Buyers' products and applications, Buyers should provide adequate design and operating safeguards.

TI does not warrant or represent that any license, either express or implied, is granted under any patent right, copyright, mask work right, or other intellectual property right relating to any combination, machine, or process in which TI components or services are used. Information published by TI regarding third-party products or services does not constitute a license to use such products or services or a warranty or endorsement thereof. Use of such information may require a license from a third party under the patents or other intellectual property of the third party, or a license from TI under the patents or other intellectual property of TI.

Reproduction of significant portions of TI information in TI data books or data sheets is permissible only if reproduction is without alteration and is accompanied by all associated warranties, conditions, limitations, and notices. TI is not responsible or liable for such altered documentation. Information of third parties may be subject to additional restrictions.

Resale of TI components or services with statements different from or beyond the parameters stated by TI for that component or service voids all express and any implied warranties for the associated TI component or service and is an unfair and deceptive business practice. TI is not responsible or liable for any such statements.

Buyer acknowledges and agrees that it is solely responsible for compliance with all legal, regulatory and safety-related requirements concerning its products, and any use of TI components in its applications, notwithstanding any applications-related information or support that may be provided by TI. Buyer represents and agrees that it has all the necessary expertise to create and implement safeguards which anticipate dangerous consequences of failures, monitor failures and their consequences, lessen the likelihood of failures that might cause harm and take appropriate remedial actions. Buyer will fully indemnify TI and its representatives against any damages arising out of the use of any TI components in safety-critical applications.

In some cases, TI components may be promoted specifically to facilitate safety-related applications. With such components, TI's goal is to help enable customers to design and create their own end-product solutions that meet applicable functional safety standards and requirements. Nonetheless, such components are subject to these terms.

No TI components are authorized for use in FDA Class III (or similar life-critical medical equipment) unless authorized officers of the parties have executed a special agreement specifically governing such use.

Only those TI components which TI has specifically designated as military grade or "enhanced plastic" are designed and intended for use in military/aerospace applications or environments. Buyer acknowledges and agrees that any military or aerospace use of TI components which have **not** been so designated is solely at the Buyer's risk, and that Buyer is solely responsible for compliance with all legal and regulatory requirements in connection with such use.

TI has specifically designated certain components as meeting ISO/TS16949 requirements, mainly for automotive use. In any case of use of non-designated products, TI will not be responsible for any failure to meet ISO/TS16949.

### Products

Audio	<a href="http://www.ti.com/audio">www.ti.com/audio</a>
Amplifiers	<a href="http://amplifier.ti.com">amplifier.ti.com</a>
Data Converters	<a href="http://dataconverter.ti.com">dataconverter.ti.com</a>
DLP® Products	<a href="http://www.dlp.com">www.dlp.com</a>
DSP	<a href="http://dsp.ti.com">dsp.ti.com</a>
Clocks and Timers	<a href="http://www.ti.com/clocks">www.ti.com/clocks</a>
Interface	<a href="http://interface.ti.com">interface.ti.com</a>
Logic	<a href="http://logic.ti.com">logic.ti.com</a>
Power Mgmt	<a href="http://power.ti.com">power.ti.com</a>
Microcontrollers	<a href="http://microcontroller.ti.com">microcontroller.ti.com</a>
RFID	<a href="http://www.ti-rfid.com">www.ti-rfid.com</a>
OMAP Applications Processors	<a href="http://www.ti.com/omap">www.ti.com/omap</a>
Wireless Connectivity	<a href="http://www.ti.com/wirelessconnectivity">www.ti.com/wirelessconnectivity</a>

### Applications

Automotive and Transportation	<a href="http://www.ti.com/automotive">www.ti.com/automotive</a>
Communications and Telecom	<a href="http://www.ti.com/communications">www.ti.com/communications</a>
Computers and Peripherals	<a href="http://www.ti.com/computers">www.ti.com/computers</a>
Consumer Electronics	<a href="http://www.ti.com/consumer-apps">www.ti.com/consumer-apps</a>
Energy and Lighting	<a href="http://www.ti.com/energy">www.ti.com/energy</a>
Industrial	<a href="http://www.ti.com/industrial">www.ti.com/industrial</a>
Medical	<a href="http://www.ti.com/medical">www.ti.com/medical</a>
Security	<a href="http://www.ti.com/security">www.ti.com/security</a>
Space, Avionics and Defense	<a href="http://www.ti.com/space-avionics-defense">www.ti.com/space-avionics-defense</a>
Video and Imaging	<a href="http://www.ti.com/video">www.ti.com/video</a>

### TI E2E Community

[e2e.ti.com](http://e2e.ti.com)

## Looking for pricing, stock, or lifecycle information?

Click below to explore more details on WIN SOURCE:

 [View TLC59482DBQR](#) on WIN SOURCE

 [Texas Instruments](#) Information

## Optimize Your Supply Chain with WIN SOURCE Solutions

-  Global Sourcing Solution
-  Obsolete Management
-  Cost Control Management
-  Shortage Management
-  Alternative Solution
-  Excess Inventory Management