



**THE DATASHEET OF
SA575DR2G**



SA575

Low Voltage Compandor

The SA575 is a precision dual gain control circuit designed for low voltage applications. The SA575's channel 1 is an expander, while channel 2 can be configured either for expander, compressor, or automatic level controller (ALC) application.

Features

- Operating Voltage Range from 3.0 V to 7.0 V
- Reference Voltage of $100 \text{ mV}_{\text{RMS}} = 0 \text{ dB}$
- One Dedicated Summing Op Amp Per Channel and Two Extra Uncommitted Op Amps
- 600Ω Drive Capability
- Single or Split Supply Operation
- Wide Input/Output Swing Capability
- Pb-Free Packages are Available*

Applications

- Portable Communications
- Cellular Radio
- Cordless Telephone
- Consumer Audio
- Portable Broadcast Mixers
- Wireless Microphones
- Modems
- Electric Organs
- Hearing Aids



ON Semiconductor®

<http://onsemi.com>

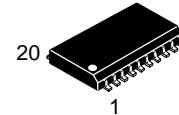

SOIC-20 WB
D SUFFIX
CASE 751D

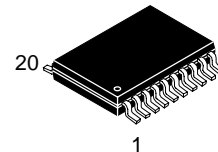

TSSOP-20
DTB SUFFIX
CASE 948E

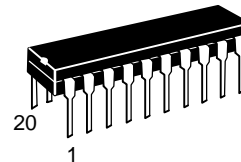

PDIP-20
N SUFFIX
CASE 738

PIN CONNECTIONS

D* and DTB Packages

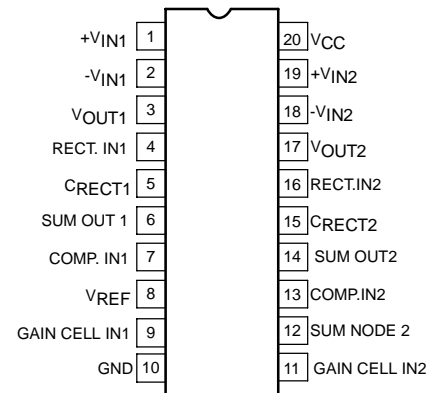

*Available in large SOL package only.

ORDERING INFORMATION

See detailed ordering and shipping information in the package dimensions section on page 13 of this data sheet.

DEVICE MARKING INFORMATION

See general marking information in the device marking section on page 13 of this data sheet.

*For additional information on our Pb-Free strategy and soldering details, please download the ON Semiconductor Soldering and Mounting Techniques Reference Manual, SOLDERRM/D.

SA575

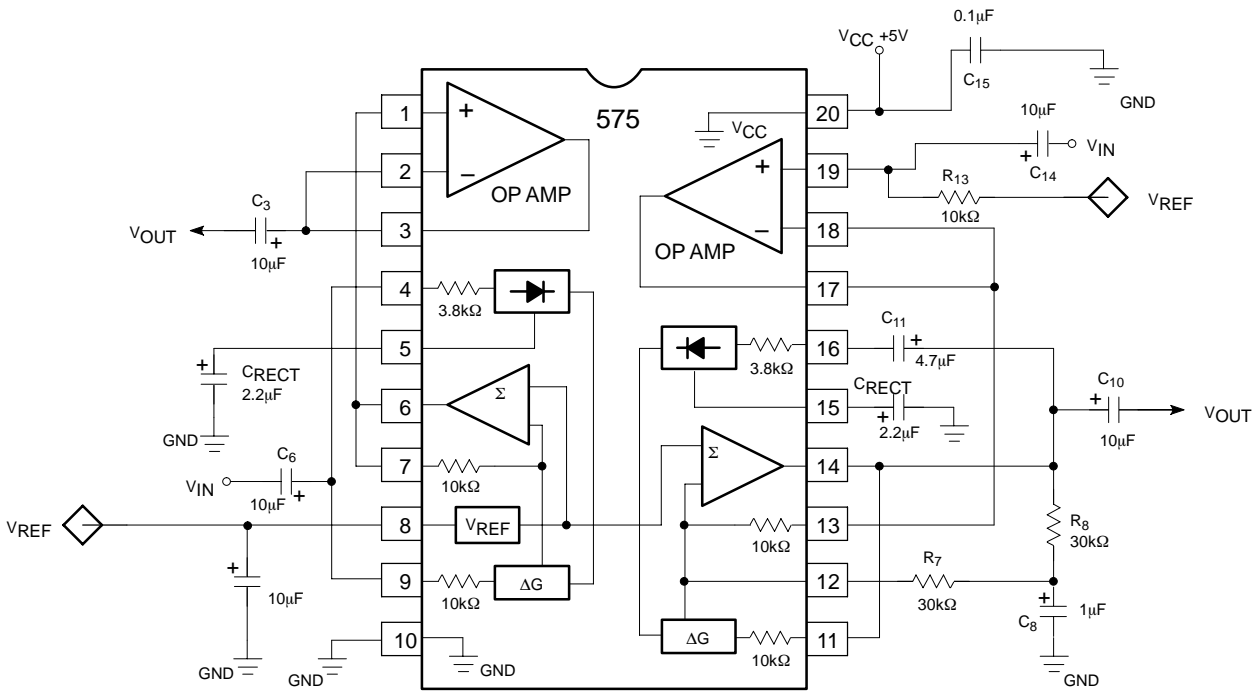

Figure 1. Block Diagram and Test Circuit

PIN FUNCTION DESCRIPTION

Pin	Symbol	Description
1	+V _{IN1}	Non-Inverted Input 1
2	-V _{IN1}	Inverted Input 1
3	V _{OUT}	Output
4	RECT. IN1	Rectifier 1 Input
5	C _{RECT1}	External Capacitor Pinout for Rectifier 1
6	SUM OUT1	Summation Output 1
7	COMP. IN1	Compensator Pin
8	V _{REF}	Voltage Reference
9	GAIN CELL IN1	Variable Gain Cell Input 1
10	GND	Ground
11	GAIN CELL IN2	Variable Gain Cell Input 2
12	SUM NODE 2	Summation Node 2
13	COMP. IN2	Compensator Pin
14	SUM OUT2	Summation Output 2
15	C _{RECT2}	External Capacitor Pinout for Rectifier 2
16	RECT. IN2	Rectifier 2 Input
17	V _{OUT2}	Output 2
18	-V _{IN2}	Inverted Input 2
19	+V _{IN2}	Non-Inverted Input 2
20	V _{CC}	Positive Power Supply

SA575

MAXIMUM RATINGS

Rating	Symbol	Value	Unit
Single Supply Voltage	V_{CC}	-0.3 to 8.0	V
Voltage Applied to Any Other Pin	V_{IN}	-0.3 to ($V_{CC} + 0.3$)	V
Operating Ambient Temperature Range	T_A	-40 to +85	°C
Operating Junction Temperature	T_J	150	°C
Storage Temperature Range	T_{STG}	150	°C
Thermal Impedance	SOIC TSSOP PDIP θ_{JA}	87 124 70	°C/W
Maximum Power Dissipation	SOIC TSSOP PDIP P_D	1116 1068 1344	mW

Maximum ratings are those values beyond which device damage can occur. Maximum ratings applied to the device are individual stress limit values (not normal operating conditions) and are not valid simultaneously. If these limits are exceeded, device functional operation is not implied, damage may occur and reliability may be affected.

DC ELECTRICAL CHARACTERISTICS Typical values are at $T_A = 25^\circ\text{C}$. Minimum and Maximum values are for the full operating temperature range: -40 to +85°C for SA575, except SSOP package is tested at +25°C only. $V_{CC} = 5.0\text{ V}$, unless otherwise stated. Both channels are tested in the Expander mode (see Test Circuit).

Characteristic	Symbol	Test Conditions	Min	Typ	Max	Unit
----------------	--------	-----------------	-----	-----	-----	------

FOR COMPANDOR, INCLUDING SUMMING AMPLIFIER

Supply Voltage (Note 1)	V_{CC}	-	3.0	5.0	7.0	V
Supply Current	I_{CC}	No Signal	3.0	4.2	5.5	mA
Reference Voltage (Note 2)	V_{REF}	$V_{CC} = 5.0\text{ V}$	2.4	2.5	2.6	V
Summing Amp Output Load	R_L	-	10	-	-	k Ω
Total Harmonic Distortion	THD	1.0 kHz, 0 dB, BW = 3.5 kHz	-	0.12	1.5	%
Output Voltage Noise	E_{NO}	BW = 20 kHz, $R_S = 0\ \Omega$	-	6.0	30	μV
Unity Gain Level	0dB	1.0 kHz	-1.5	-	1.5	dB
Output Voltage Offset	V_{OS}	No Signal	-150	-	150	mV
Output DC Shift		No Signal to 0 dB	-100	-	100	mV
Tracking Error Relative to 0 dB		Gain Cell Input = 0 dB, 1.0 kHz Rectifier Input = 6.0 dB, 1.0 kHz	-1.0	-	1.0	dB
		Gain Cell Input = 0 dB, 1.0 kHz Rectifier Input = -30 dB, 1.0 kHz	-1.0	-	1.0	dB
Crosstalk		1.0 kHz, 0 dB, $C_{REF} = 220\ \mu\text{F}$	-	-80	-65	dB

FOR OPERATIONAL AMPLIFIER

Output Swing	V_O	$R_L = 10\ \text{k}\Omega$	$V_{CC}-0.4$	V_{CC}	-	V
Output Load	R_L	1.0 kHz	600	-	-	Ω
Input Common-Mode Range	CMR	-	0	-	V_{CC}	V
Common-Mode Rejection Ratio	CMRR	-	60	80	-	dB
Input Bias Current	I_B	$V_{IN} = 0.5\text{ V to }4.5\text{ V}$	-1.0	-	1.0	μA
Input Offset Voltage	V_{OS}	-	-	3.0	-	mV
Open-Loop Gain	A_{VOL}	$R_L = 10\ \text{k}\Omega$	-	80	-	dB
Slew Rate	SR	Unity Gain	-	1.0	-	V/ μs
Bandwidth	GBW	Unity Gain	-	3.0	-	MHz
Input Voltage Noise	E_{NI}	BW = 20 kHz	-	2.5	-	μV
Power Supply Rejection Ratio	PSRR	1.0 kHz, 250 mV	-	60	-	dB

1. Operation down to $V_{CC} = 2.0\text{ V}$ is possible, but performance is reduced. See curves in Figures 6 and 7.
2. Reference voltage, V_{REF} , is typically at $1/2\ V_{CC}$.

Functional Description

This section describes the basic subsystems and applications of the SA575 Compressor. More theory of operation on compressors can be found in AND8159 and AND8160. The typical applications of the SA575 low voltage compressor in an Expander (1:2), Compressor (2:1) and Automatic Level Control (ALC) function are explained. These three circuit configurations are shown in Figures 2, 3, and 4 respectively.

The SA575 has two channels for a complete compressing system. The left channel, A, can be configured as a 1:2 Expander while the right channel, B, can be configured as either a 2:1 Compressor, a 1:2 Expander or an ALC. Each channel consists of the basic compressing building blocks of rectifier cell, variable gain cell, summing amplifier and V_{REF} cell. In addition, the SA575 has two additional high performance uncommitted op amps which can be utilized for application such as filtering, pre-emphasis/de-emphasis or buffering.

Figure 5 shows the complete schematic for the applications demo board. Channel A is configured as an expander while channel B is configured so that it can be used either as a compressor or as an ALC circuit. The switch, S_1 , toggles the circuit between compressor and ALC mode. Jumpers J_1 and J_2 can be used to either include the additional op amps for signal conditioning or exclude them from the signal path. Bread boarding space is provided for R_1 , R_2 , C_1 , C_2 , R_{10} , R_{11} , C_{10} and C_{11} so that the response can be tailored for each individual need. The components as specified are suitable for the complete audio spectrum from 20 Hz to 20 kHz.

The most common configuration is as a unity gain non-inverting buffer where R_1 , C_1 , C_2 , R_{10} , C_{10} and C_{11} are eliminated and R_2 and R_{11} are shorted. Capacitors C_3 , C_5 , C_8 , and C_{12} are for DC blocking. In systems where the inputs and outputs are AC coupled, these capacitors and resistors can be eliminated. Capacitors C_4 and C_9 are for setting the attack and release time constant.

C_6 is for decoupling and stabilizing the voltage reference circuit. The value of C_6 should be such that it will offer a very low impedance to the lowest frequencies of interest. Too small a capacitor will allow supply ripple to modulate the audio path. The better filtered the power supply, the smaller this capacitor can be. R_{12} provides DC reference voltage to the amplifier of channel B. R_6 and R_7 provide a DC feedback path for the summing amp of channel B, while C_7 is a short-circuit to ground for signals. C_{14} and C_{15} are for power supply decoupling. C_{14} can also be eliminated if the power supply is well regulated with very low noise and ripple.

Demonstrated Performance

The applications demo board was built and tested for a frequency range of 20 Hz to 20 kHz with the component values as shown in Figure 5 and $V_{CC} = 5.0$ V. In the expander mode, the typical input dynamic range was from -34 dB to +12 dB where 0 dB is equal to 100 mV_{RMS}. The typical unity gain level measured at 0 dB @ 1.0 kHz input was ± 0.5 dB and the typical tracking error was ± 0.1 dB for input range of -30 to +10 dB.

In the compressor mode, the typical input dynamic range was from -42 dB to ± 18 dB with a tracking error ± 0.1 dB and the typical unity gain level was ± 0.5 dB.

In the ALC mode, the typical input dynamic range was from -42 dB to +8.0 dB with typical output deviation of ± 0.2 dB about the nominal output of 0 dB. For input greater than +9.0 dB in ALC configuration, the summing amplifier sometimes exhibits high frequency oscillations. There are several solutions to this problem. The first is to lower the values of R_6 and R_7 to 20 k Ω each. The second is to add a current limiting resistor in series with C_{12} at Pin 13. The third is to add a compensating capacitor of about 22 to 30 pF between the input and output of summing amplifier (Pins 12 and 14). With any one of the above recommendations, the typical ALC mode input range increased to +18 dB yielding a dynamic range of over 60 dB.

Expander

The typical expander configuration is shown in Figure 2. The variable gain cell and the rectifier cell are in the signal input path. The V_{REF} is always $1/2 V_{CC}$ to provide the maximum headroom without clipping. The 0 dB ref is 100 mV_{RMS}. The input is AC coupled through C_5 , and the output is AC coupled through C_3 . If in a system the inputs and outputs are AC coupled, then C_3 and C_5 can be eliminated, thus requiring only one external component, C_4 . The variable gain cell and rectifier cell are DC coupled so any offset voltage between Pins 4 and 9 will cause small offset error current in the rectifier cell. This will affect the

accuracy of the gain cell. This can be improved by using an extra capacitor from the input to Pin 4 and eliminating the DC connection between Pins 4 and 9.

The expander gain expression and the attack and release time constant is given by Equation 1 and Equation 2, respectively.

$$\text{Expander gain} = \left(\frac{4V_{IN(\text{avg})}}{3.8 \text{ k}\Omega \times 100 \text{ }\mu\text{A}} \right)^2 \quad (\text{eq. 1})$$

$$\text{where } V_{IN(\text{avg})} = 0.95V_{IN(\text{RMS})}$$

$$\tau_R = \tau_A = 10 \text{ k}\Omega \times C_{RECT} = 10 \text{ k}\Omega \times C_4 \quad (\text{eq. 2})$$

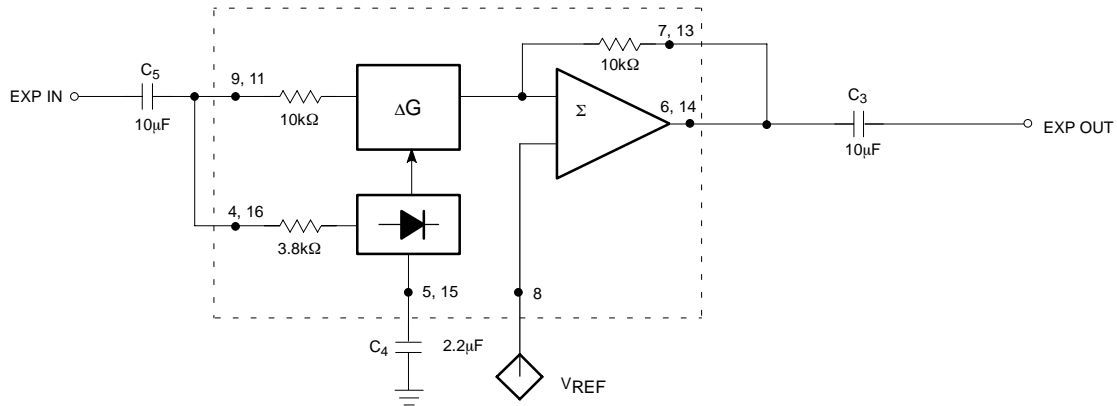

Figure 2. Typical Expander Configuration

Compressor

The typical compressor configuration is shown in Figure 3. In this mode, the rectifier cell and variable gain cell are in the feedback path. R_6 and R_7 provide the DC feedback to the summing amplifier. The input is AC coupled through C_{12} and output is AC coupled through C_8 . In a system with inputs and outputs AC coupled, C_8 and C_{12} could be eliminated and only R_6 , R_7 , C_7 , and C_{13} would be required. If the external components R_6 , R_7 and C_7 are eliminated, then the output of the summing amplifier will motor-boat in absence of signals or at extremely low signals. This is because there is no DC feedback path from

the output to input. In the presence of an AC signal this phenomenon is not observed and the circuit will appear to function properly.

The compressor gain expression and the attack and release time constant is given by Equation 3 and Equation 4, respectively.

$$\text{Compressor gain} = \left[\frac{3.8 \text{ k}\Omega \times 100 \mu\text{A}}{4V_{IN(\text{avg})}} \right]^{1/2} \quad (\text{eq. 3})$$

$$\text{where } V_{IN(\text{avg})} = 0.95V_{IN(\text{RMS})}$$

$$\tau_R = \tau_A = 10 \text{ k}\Omega \times C_{RECT} = 10 \text{ k}\Omega \times C_4 \quad (\text{eq. 4})$$

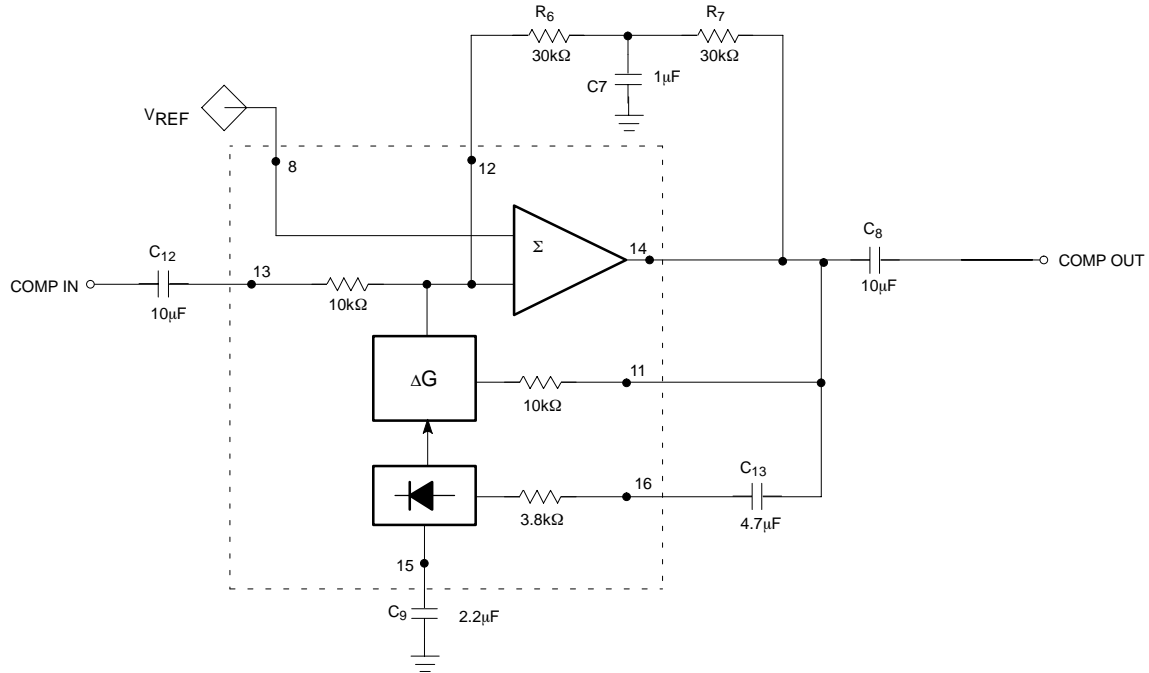

Figure 3. Typical Compressor Configuration

Automatic Level Control

The typical Automatic Level Control circuit configuration is shown in Figure 4. It can be seen that it is quite similar to the compressor schematic except that the input to the rectifier cell is from the input path and not from the feedback path. The input is AC coupled through C_{12} and C_{13} and the output is AC coupled through C_8 . Once again, as in the previous cases, if the system input and output signals are already AC coupled, then C_{12} , C_{13} and C_8 could be eliminated. Concerning the compressor, removing R_6 , R_7 and C_7 will cause motor-boating in

absence of signals. C_{COMP} is necessary to stabilize the summing amplifier at higher input levels. This circuit provides an input dynamic range greater than 60 dB with the output within ± 0.5 dB typical. The necessary design expressions are given by Equation 5 and Equation 6, respectively.

$$\text{ALC gain} = \frac{3.8 \text{ k}\Omega \times 100 \text{ }\mu\text{A}}{4V_{IN(\text{avg})}} \quad (\text{eq. 5})$$

$$\tau_R = \tau_A = 10 \text{ k}\Omega \times C_{RECT} = 10 \text{ k}\Omega \times C_9 \quad (\text{eq. 6})$$

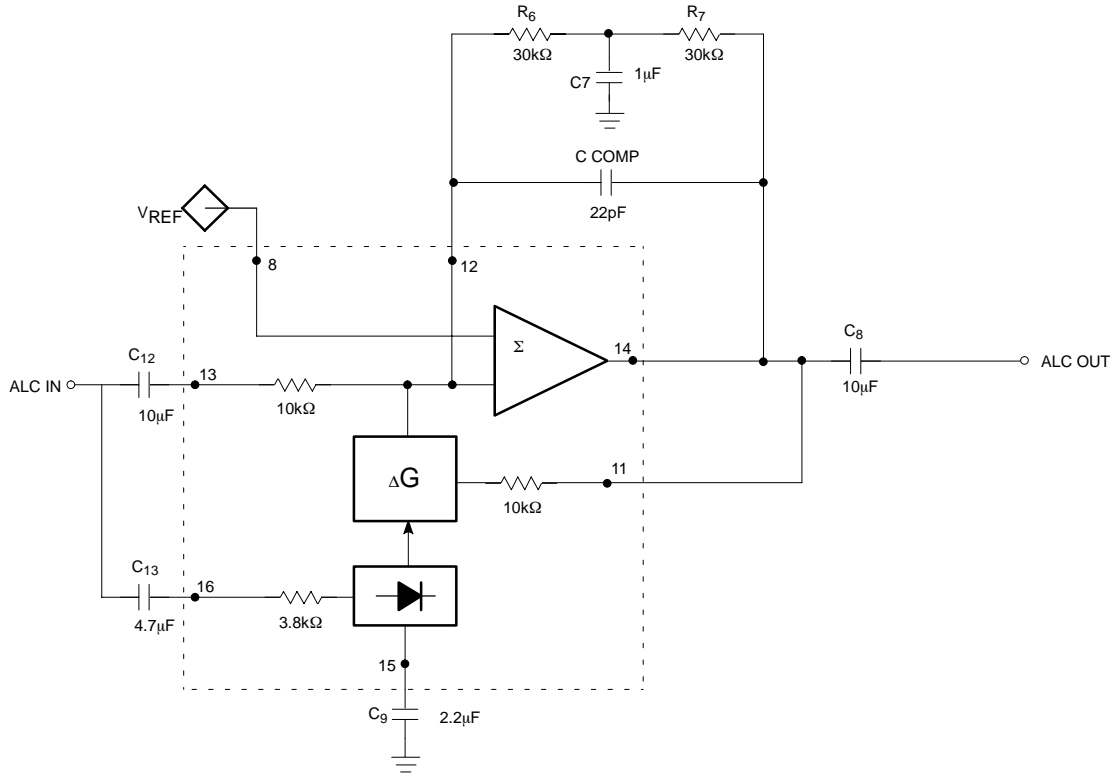

Figure 4. Typical ALC Configuration

SA575

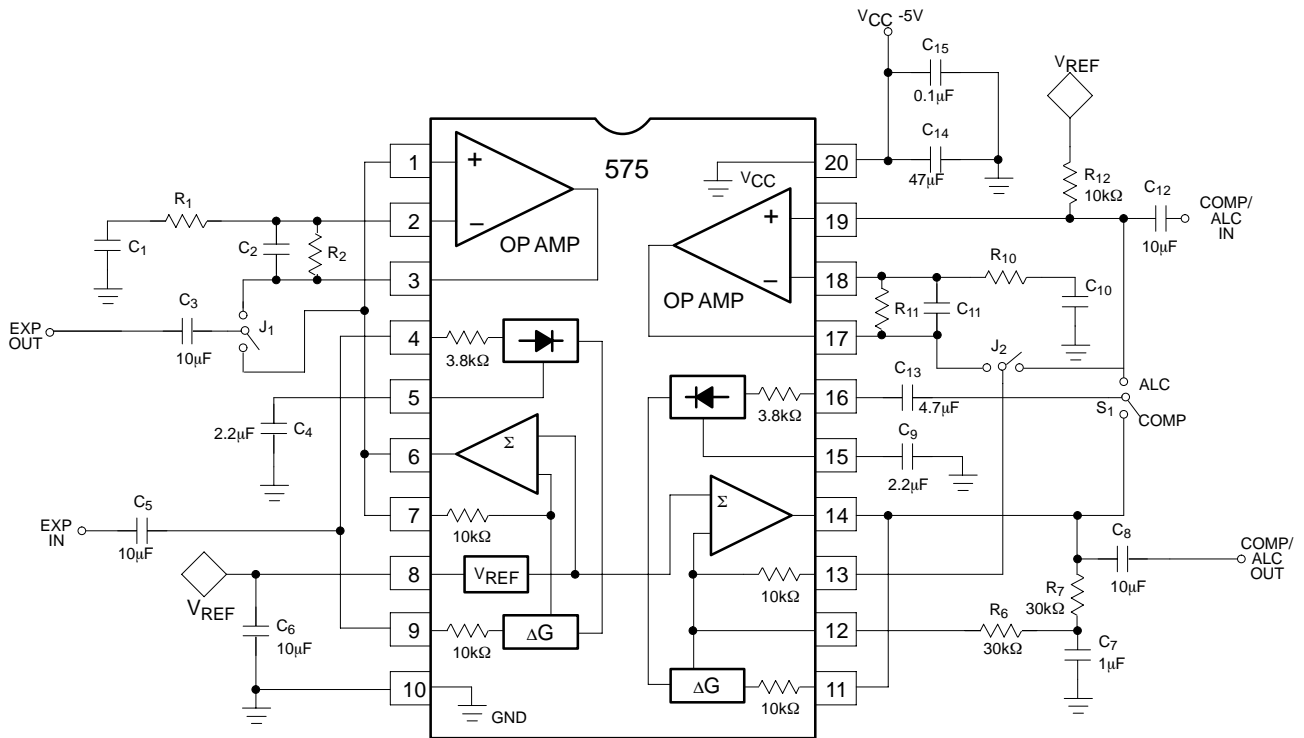

Figure 5. SA575 Low Voltage Expander/Compressor/ALC Demo Board

SA575

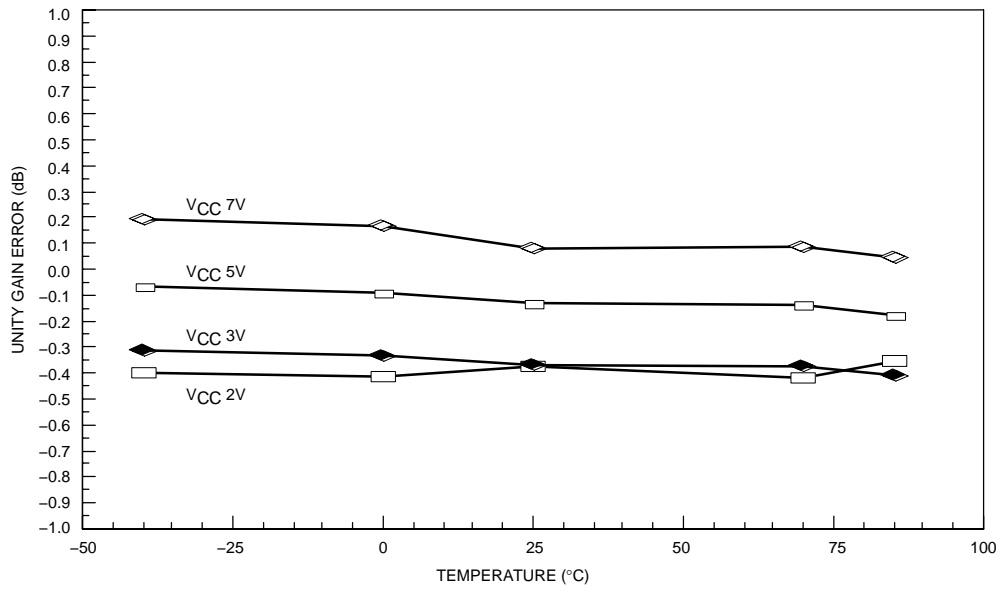

Figure 6. Unity Gain Error vs. Temperature and V_{CC}

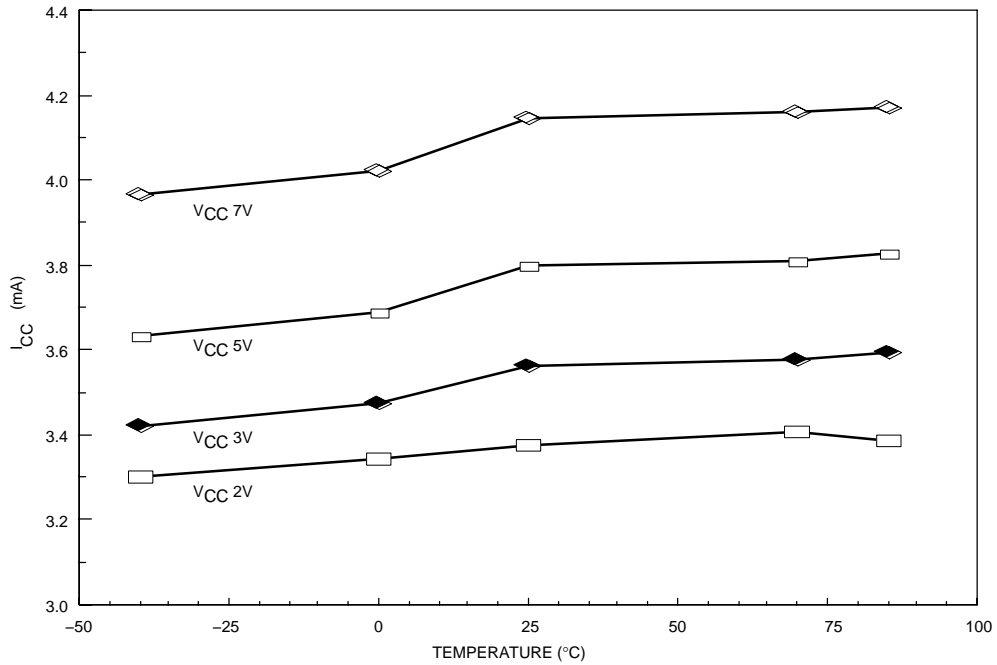

Figure 7. I_{CC} vs. Temperature and V_{CC}

SA575

TYPICAL PERFORMANCE CHARACTERISTICS

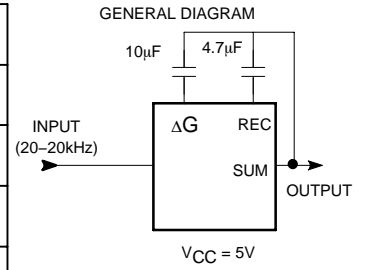
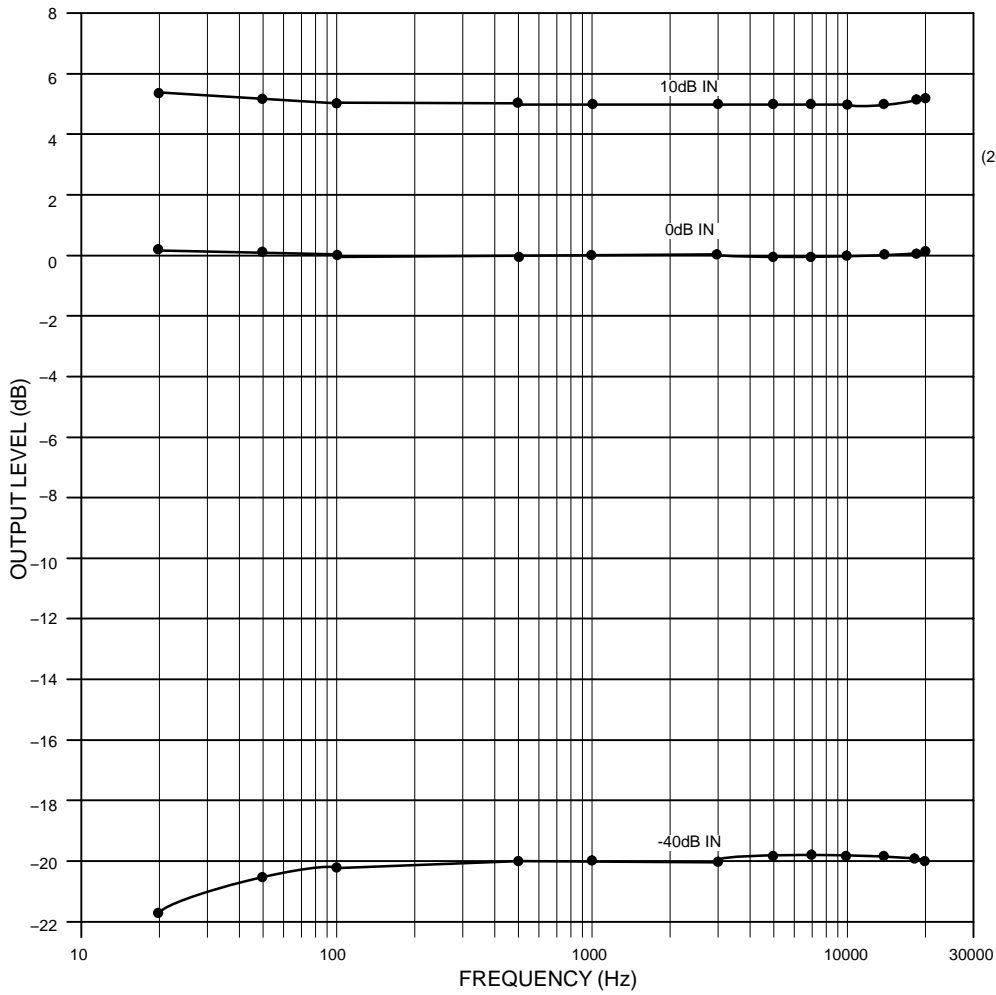

Figure 8. Compressor Output Frequency Response

SA575

TYPICAL PERFORMANCE CHARACTERISTICS

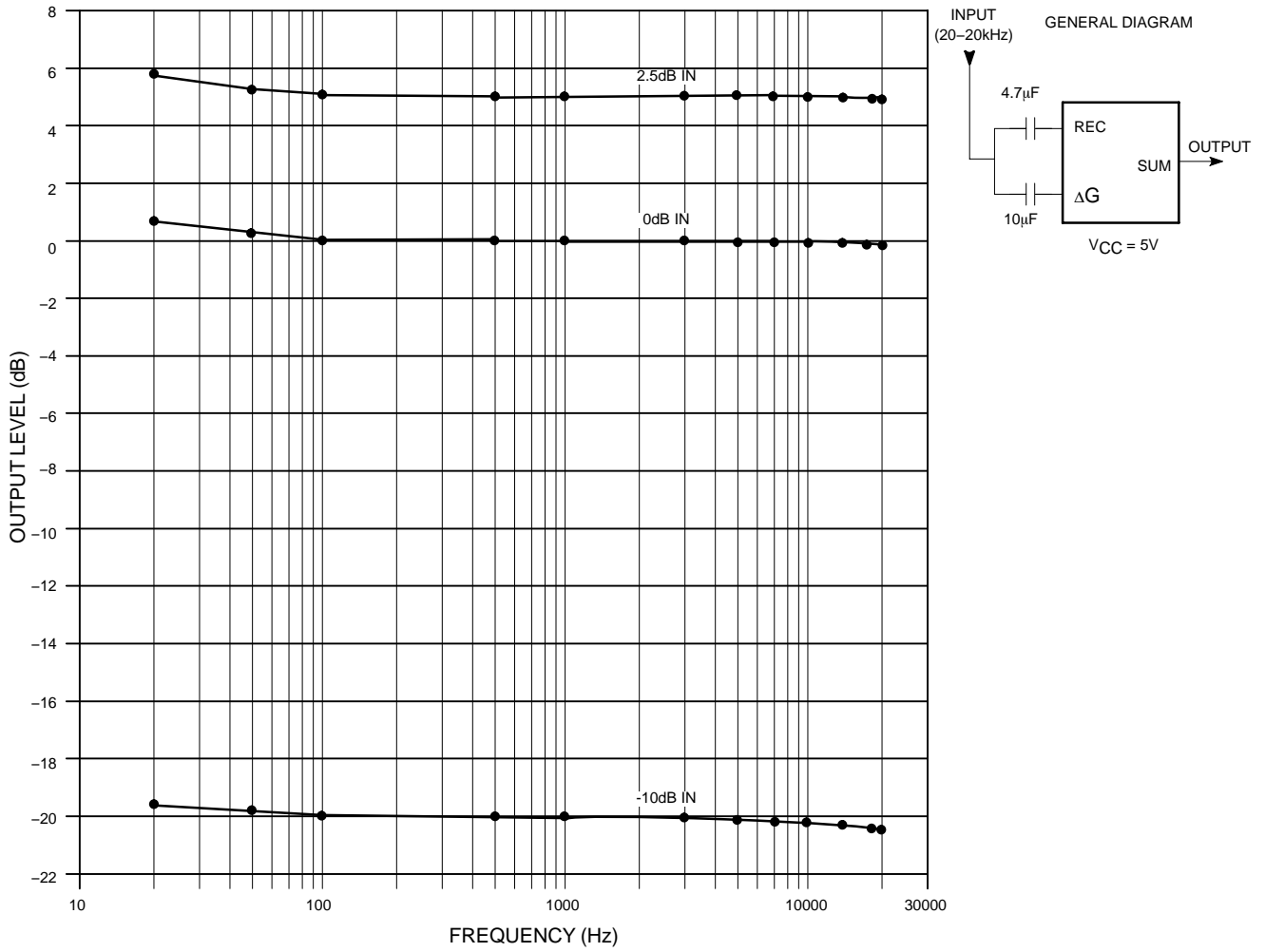

Figure 9. Expander Output Frequency Response

SA575

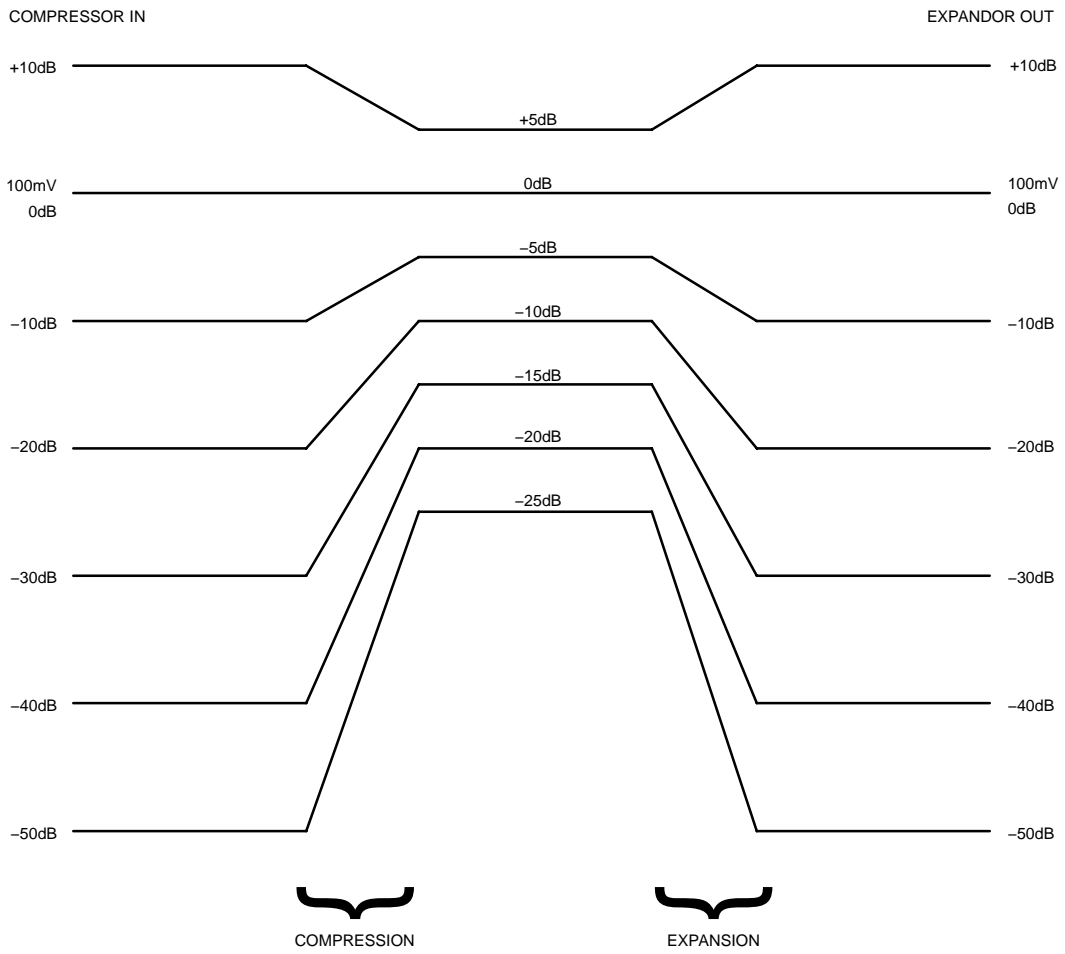

Figure 10. The Companding Function

SA575

ORDERING INFORMATION

Device	Package	Temperature Range	Shipping†
SA575D	SOIC-20 WB	-40 to +85°C	38 Units / Rail
SA575DR2	SOIC-20 WB	-40 to +85°C	1000 / Tape & Reel
SA575DR2G	SOIC-20 WB (Pb-Free)	-40 to +85°C	1000 / Tape & Reel
SA575DTB	TSSOP-20*	-40 to +85°C	75 Units / Rail
SA575DTBR2	TSSOP-20*	-40 to +85°C	2500 Tape & Reel
SA575N	PDIP-20	-40 to +85°C	18 Units / Rail

†For information on tape and reel specifications, including part orientation and tape sizes, please refer to our Tape and Reel Packaging Specification Brochure, BRD8011/D.

*This package is inherently Pb-Free.

MARKING DIAGRAMS

**SOIC-20 WB
D SUFFIX
CASE 751D**

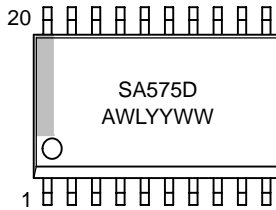

**TSSOP-20
DTB SUFFIX
CASE 948E**

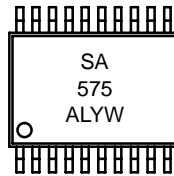

**PDIP-20
N SUFFIX
CASE 738**



A = Assembly Location
 WL, L = Wafer Lot
 YY, Y = Year
 WW, W = Work Week

SA575

PACKAGE DIMENSIONS

SO-20 WB
CASE 751D-05
ISSUE G

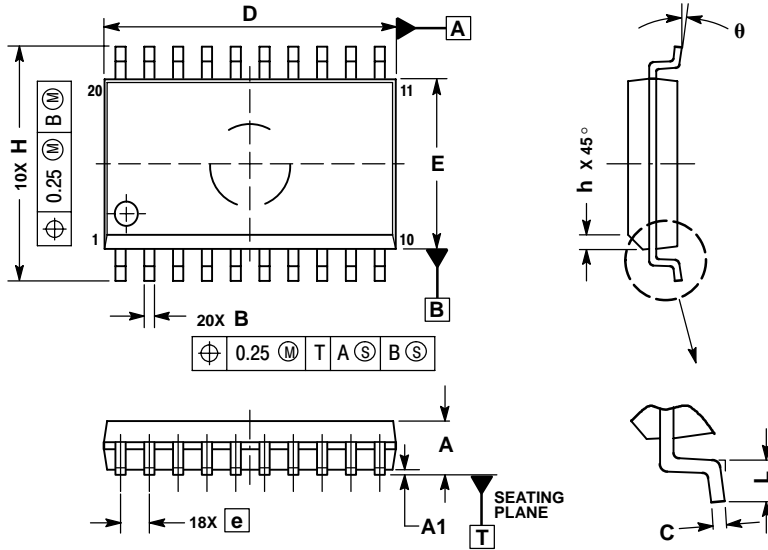

- NOTES:
1. DIMENSIONS ARE IN MILLIMETERS.
 2. INTERPRET DIMENSIONS AND TOLERANCES PER ASME Y14.5M, 1994.
 3. DIMENSIONS D AND E DO NOT INCLUDE MOLD PROTRUSION.
 4. MAXIMUM MOLD PROTRUSION 0.15 PER SIDE.
 5. DIMENSION B DOES NOT INCLUDE DAMBAR PROTRUSION. ALLOWABLE PROTRUSION SHALL BE 0.13 TOTAL IN EXCESS OF B DIMENSION AT MAXIMUM MATERIAL CONDITION.

DIM	MILLIMETERS	
	MIN	MAX
A	2.35	2.65
A1	0.10	0.25
B	0.35	0.49
C	0.23	0.32
D	12.65	12.95
E	7.40	7.60
e	1.27 BSC	
H	10.05	10.55
h	0.25	0.75
L	0.50	0.90
θ	0°	7°

SA575

PACKAGE DIMENSIONS

PDIP-20
N SUFFIX
CASE 738-03
ISSUE E

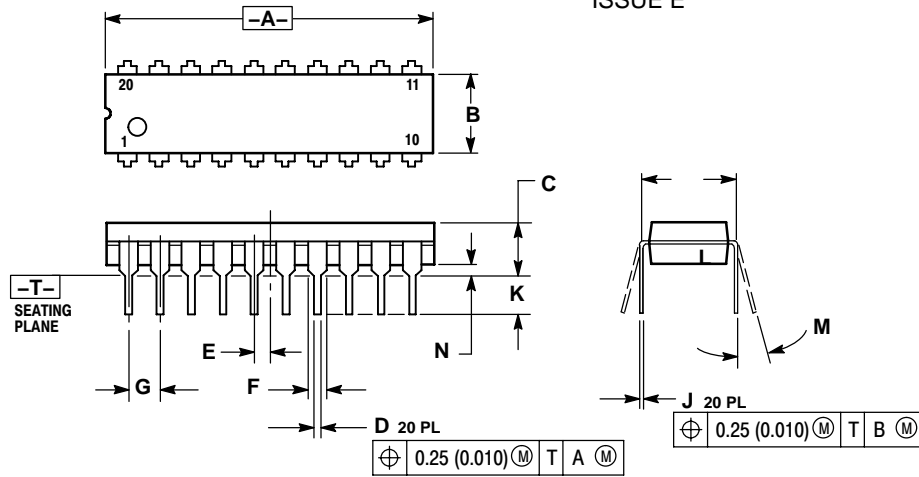

NOTES:

1. DIMENSIONING AND TOLERANCING PER ANSI Y14.5M, 1982.
2. CONTROLLING DIMENSION: INCH.
3. DIMENSION L TO CENTER OF LEAD WHEN FORMED PARALLEL.
4. DIMENSION B DOES NOT INCLUDE MOLD FLASH.

DIM	INCHES		MILLIMETERS	
	MIN	MAX	MIN	MAX
A	1.010	1.070	25.66	27.17
B	0.240	0.260	6.10	6.60
C	0.150	0.180	3.81	4.57
D	0.015	0.022	0.39	0.55
E	0.050 BSC		1.27 BSC	
F	0.050	0.070	1.27	1.77
G	0.100 BSC		2.54 BSC	
J	0.008	0.015	0.21	0.38
K	0.110	0.140	2.80	3.55
L	0.300 BSC		7.62 BSC	
M	0°	15°	0°	15°
N	0.020	0.040	0.51	1.01

ON Semiconductor and are registered trademarks of Semiconductor Components Industries, LLC (SCILLC). SCILLC reserves the right to make changes without further notice to any products herein. SCILLC makes no warranty, representation or guarantee regarding the suitability of its products for any particular purpose, nor does SCILLC assume any liability arising out of the application or use of any product or circuit, and specifically disclaims any and all liability, including without limitation special, consequential or incidental damages. "Typical" parameters which may be provided in SCILLC data sheets and/or specifications can and do vary in different applications and actual performance may vary over time. All operating parameters, including "Typicals" must be validated for each customer application by customer's technical experts. SCILLC does not convey any license under its patent rights nor the rights of others. SCILLC products are not designed, intended, or authorized for use as components in systems intended for surgical implant into the body, or other applications intended to support or sustain life, or for any other application in which the failure of the SCILLC product could create a situation where personal injury or death may occur. Should Buyer purchase or use SCILLC products for any such unintended or unauthorized application, Buyer shall indemnify and hold SCILLC and its officers, employees, subsidiaries, affiliates, and distributors harmless against all claims, costs, damages, and expenses, and reasonable attorney fees arising out of, directly or indirectly, any claim of personal injury or death associated with such unintended or unauthorized use, even if such claim alleges that SCILLC was negligent regarding the design or manufacture of the part. SCILLC is an Equal Opportunity/Affirmative Action Employer. This literature is subject to all applicable copyright laws and is not for resale in any manner.

PUBLICATION ORDERING INFORMATION

LITERATURE FULFILLMENT:
Literature Distribution Center for ON Semiconductor
P.O. Box 5163, Denver, Colorado 80217 USA
Phone: 303-675-2175 or 800-344-3860 Toll Free USA/Canada
Fax: 303-675-2176 or 800-344-3867 Toll Free USA/Canada
Email: orderlit@onsemi.com

N. American Technical Support: 800-282-9855 Toll Free
USA/Canada
Europe, Middle East and Africa Technical Support:
Phone: 421 33 790 2910
Japan Customer Focus Center
Phone: 81-3-5773-3850

ON Semiconductor Website: www.onsemi.com
Order Literature: <http://www.onsemi.com/orderlit>

For additional information, please contact your local Sales Representative

Looking for pricing, stock, or lifecycle information?

Click below to explore more details on WIN SOURCE:

 [View SA575DR2G on WIN SOURCE](#)

 [ON Semiconductor](#) Information

Optimize Your Supply Chain with WIN SOURCE Solutions

-  Global Sourcing Solution
-  Obsolete Management
-  Cost Control Management
-  Shortage Management
-  Alternative Solution
-  Excess Inventory Management