



THE DATASHEET OF L6226D



DMOS dual full bridge driver

Datasheet - production data



- Undervoltage lockout
- Integrated fast free wheeling diodes

Applications

- Bipolar stepper motor
- Dual or quad DC motor

Features

- Operating supply voltage from 8 to 52 V
- 2.8 A output peak current (1.4 A DC)
- $R_{DS(on)}$ 0.73 Ω typ. value at $T_J = 25\text{ }^\circ\text{C}$
- Operating frequency up to 100 kHz
- Programmable high side overcurrent detection and protection
- Diagnostic output
- Paralleled operation
- Cross conduction protection
- Thermal shutdown

Description

The L6226 is a DMOS dual full bridge designed for motor control applications, realized in multipower-BCD technology, which combines isolated DMOS power transistors with CMOS and bipolar circuits on the same chip. Available in PowerSO36 and SO24 (20+2+2) packages, the L6226 features thermal shutdown and a non-dissipative overcurrent detection on the high side power MOSFETs plus a diagnostic output that can be easily used to implement the overcurrent protection.

Figure 1. Block diagram

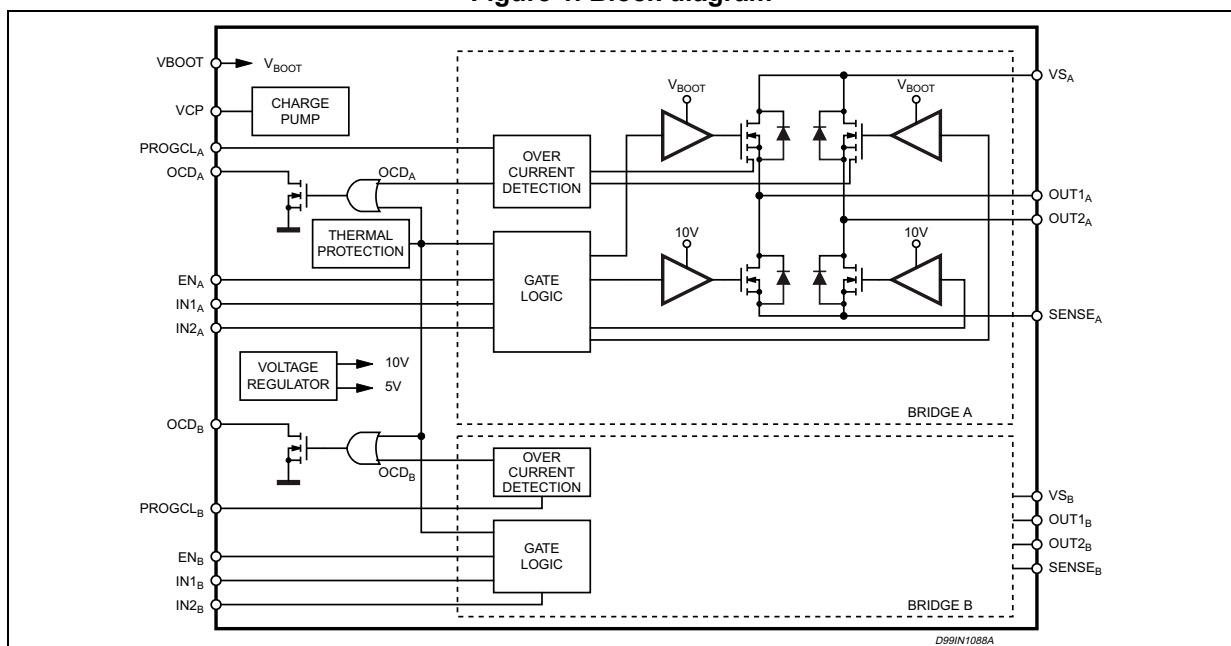

Contents

- 11 Maximum ratings 3**
 - 1.1 Absolute maximum ratings 3
 - 1.2 Recommended operating conditions 3
 - 1.3 Thermal data 4

- 2 Pin connections 5**

- 3 Electrical characteristics 7**

- 4 Circuit description 10**
 - 4.1 Power stages and charge pump 10
 - 4.2 Logic inputs 10
 - 4.3 Non-dissipative overcurrent detection and protection 12
 - 4.4 Thermal protection 15

- 5 Application information 16**

- 6 Paralleled operation 18**
 - Output current capability and IC power dissipation. 21

- 7 Thermal management 23**

- 8 Package information 24**
 - 8.1 PowerSO36 package information 24
 - 8.2 SO24 package information 26

- 9 Ordering codes 27**

- 10 Revision history 28**

1 Maximum ratings

1.1 Absolute maximum ratings

Table 1. Absolute maximum ratings

Symbol	Parameter	Test conditions	Value	Unit
V_S	Supply voltage	$V_{SA} = V_{SB} = V_S$	60	V
V_{OD}	Differential voltage between V_{SA} , $OUT1_A$, $OUT2_A$, $SENSE_A$ and V_{SB} , $OUT1_B$, $OUT2_B$, $SENSE_B$	$V_{SA} = V_{SB} = V_S = 60\text{ V}$; $V_{SENSE_A} = V_{SENSE_B} = \text{GND}$	60	V
OCD_A , OCD_B	OCD pins voltage range	-	-0.3 to +10	V
$PROGCL_A$, $PROGCL_B$	PROGCL pins voltage range	-	-0.3 to +7	V
V_{BOOT}	Bootstrap peak voltage	$V_{SA} = V_{SB} = V_S$	$V_S + 10$	V
V_{IN}, V_{EN}	Input and enable voltage range	-	-0.3 to +7	V
V_{SENSE_A} , V_{SENSE_B}	Voltage range at pins $SENSE_A$ and $SENSE_B$	-	-1 to +4	V
$I_{S(\text{peak})}$	Pulsed supply current (for each V_S pin), internally limited by the overcurrent protection	$V_{SA} = V_{SB} = V_S$; $t_{PULSE} < 1\text{ ms}$	3.55	A
I_S	RMS supply current (for each V_S pin)	$V_{SA} = V_{SB} = V_S$	1.4	A
T_{stg} , T_{OP}	Storage and operating temperature range	-	-40 to 150	°C

1.2 Recommended operating conditions

Table 2. Recommended operating conditions

Symbol	Parameter	Test conditions	Min.	Max.	Unit
V_S	Supply voltage	$V_{SA} = V_{SB} = V_S$	8	52	V
V_{OD}	Differential voltage between V_{SA} , $OUT1_A$, $OUT2_A$, $SENSE_A$ and V_{SB} , $OUT1_B$, $OUT2_B$, $SENSE_B$	$V_{SA} = V_{SB} = V_S$; $V_{SENSE_A} = V_{SENSE_B}$	-	52	V
V_{SENSE_A} , V_{SENSE_B}	voltage range at pins $SENSE_A$ and $SENSE_B$	(pulsed $t_W < t_{rr}$) (DC)	-6 -1	6 1	V V
I_{OUT}	RMS output current	-	-	1.4	A
f_{sw}	Switching frequency	-	-	100	kHz

1.3 Thermal data

Table 3. Thermal data

Symbol	Description	SO24	PowerSO36	Unit
Rth-j-pins	Maximum thermal resistance junction-pins	15	-	°C/W
Rth-j-case	Maximum thermal resistance junction-case	-	2	°C/W
Rth-j-amb1	Maximum thermal resistance junction-ambient 1	52	-	°C/W
Rth-j-amb1	Maximum thermal resistance junction-ambient 2	-	36	°C/W
Rth-j-amb1	Maximum thermal resistance junction-ambient 3	-	16	°C/W
Rth-j-amb2	Maximum thermal resistance junction-ambient 4	78	63	°C/W

2 Pin connections

Figure 2. Pin connections

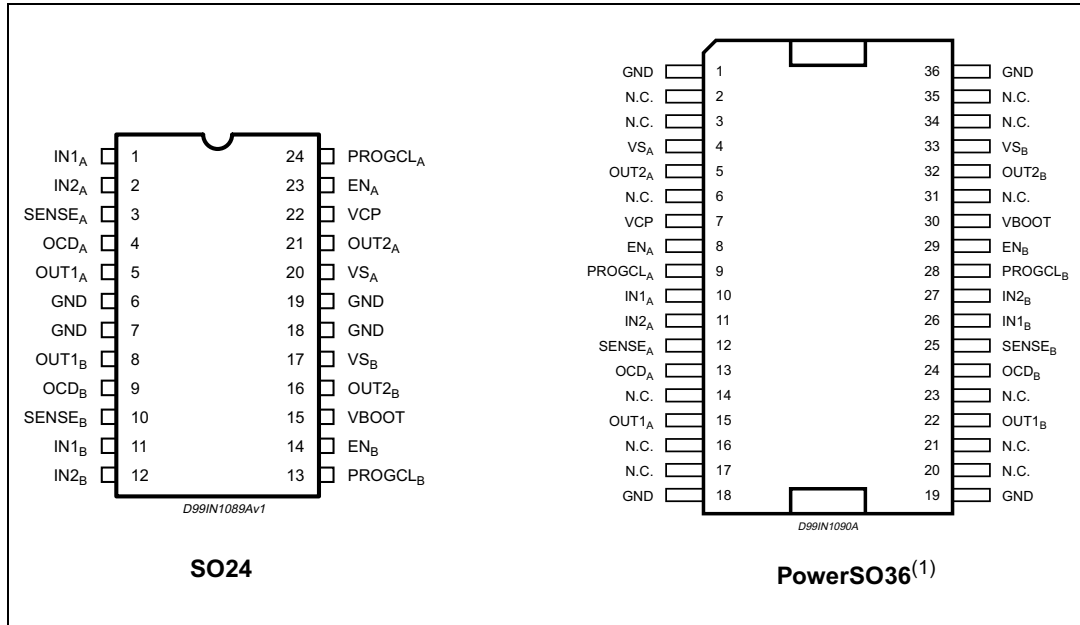

1. The slug is internally connected to pins 1,18,19 and 36 (GND pins).

Table 4. Pin description

Pin no.		Name	Type	Function
SO24	PowerSO36			
1	10	IN1A	Logic input	Bridge A logic input 1.
2	11	IN2A	Logic input	Bridge A logic input 2.
3	12	SENSEA	Power supply	Bridge A source pin. This pin must be connected to power ground directly or through a sensing power resistor.
4	13	OCD _A	Open drain output	Bridge A overcurrent detection and thermal protection pin. An internal open drain transistor pulls to GND when overcurrent on bridge A is detected or in case of thermal protection.
5	15	OUT1A	Power output	Bridge A output 1.
6, 7, 18, 19	1, 18, 19, 36	GND	GND	Signal ground terminals. In SO packages, these pins are also used for heat dissipation toward the PCB.
8	22	OUT1B	Power output	Bridge B output 1.

Table 4. Pin description (continued)

Pin no.		Name	Type	Function
SO24	PowerSO36			
9	24	OCDB	Open drain output	Bridge B overcurrent detection and thermal protection pin. An internal open drain transistor pulls to GND when overcurrent on bridge B is detected or in case of thermal protection.
10	25	SENSEB	Power supply	Bridge B source pin. This pin must be connected to power ground directly or through a sensing power resistor.
11	26	IN1B	Logic input	Bridge B input 1
12	27	IN2B	Logic input	Bridge B input 2
13	28	PROGCLB	R pin	Bridge B overcurrent level programming. A resistor connected between this pin and Ground sets the programmable current limiting value for the bridge B. By connecting this pin to Ground the maximum current is set. This pin cannot be left non-connected.
14	29	ENB	Logic input	Bridge B enable. LOW logic level switches OFF all power MOSFETs of bridge B. If not used, it has to be connected to +5 V.
15	30	VBOOT	Supply voltage	Bootstrap voltage needed for driving the upper power MOSFETs of both bridge A and bridge B.
16	32	OUT2B	Power output	Bridge B output 2.
17	33	VSB	Power supply	Bridge B power supply voltage. it must be connected to the supply voltage together with pin VSA.
20	4	VSA	Power supply	Bridge A power supply voltage. it must be connected to the supply voltage together with pin VSB.
21	5	OUT2A	Power output	Bridge A output 2.
22	7	VCP	Output	Charge pump oscillator output.
23	8	ENA	Logic input	Bridge A enable. LOW logic level switches OFF all power MOSFETs of bridge A. If not used, it has to be connected to +5 V.
24	9	PROGCLA	R pin	Bridge A overcurrent level programming. A resistor connected between this pin and Ground sets the programmable current limiting value for the bridge A. By connecting this pin to ground the maximum current is set. This pin cannot be left non-connected.

3 Electrical characteristics

$T_A = 25\text{ °C}$, $V_S = 48\text{ V}$, unless otherwise specified

Table 5. Electrical characteristics

Symbol	Parameter	Test conditions	Min.	Typ.	Max.	Unit
$V_{Sth(ON)}$	Turn-on threshold	-	5.8	6.3	6.8	V
$V_{Sth(OFF)}$	Turn-off threshold	-	5	5.5	6	V
I_S	Quiescent supply current	All bridges OFF; $T_J = -25\text{ °C}$ to $125\text{ °C}^{(1)}$	-	5	10	m
$T_{j(OFF)}$	Thermal shutdown temperature	-	-	165	-	°C
Output DMOS transistors						
$R_{DS(ON)}$	High-side + low-side switch ON resistance	$T_J = 25\text{ °C}$	-	1.47	1.69	Ω
		$T_J = 125\text{ °C}^{(1)}$	-	2.35	2.70	
I_{DSS}	Leakage current	EN = Low; OUT = V_S	-	-	2	mA
		EN = Low; OUT = GND	-0.3	-	-	mA
Source drain diodes						
V_{SD}	Forward ON voltage	$I_{SD} = 2.8\text{ A}$, EN = LOW	-	1.15	1.3	V
t_{rr}	Reverse recovery time	$I_f = 1.4\text{ A}$	-	300	-	ns
t_{fr}	Forward recovery time	-	-	200	-	ns
Logic input						
V_{IL}	Low level logic input voltage	-	-0.3	-	0.8	V
V_{IH}	High level logic input voltage	-	2	-	7	V
I_{IL}	Low level logic input current	GND logic input voltage	-10	-	-	μA
I_{IH}	High level logic input current	7 V logic input voltage	-	-	10	μA
$V_{th(ON)}$	Turn-on input threshold	-	-	1.8	2.0	V
$V_{th(OFF)}$	Turn-off input threshold	-	0.8	1.3	-	V
$V_{th(HYS)}$	Input threshold hysteresis	-	0.25	0.5	-	V
Switching characteristics						
$t_{D(on)EN}$	Enable to out turn ON delay time ⁽²⁾	$I_{LOAD} = 1.4\text{ A}$, resistive load	500	-	800	ns
$t_{D(on)IN}$	Input to out turn ON delay time	$I_{LOAD} = 1.4\text{ A}$, resistive load (dead time included)	-	1.9	-	μs
t_{RISE}	Output rise time ⁽²⁾	$I_{LOAD} = 1.4\text{ A}$, resistive load	40	-	250	ns
$t_{D(off)EN}$	Enable to out turn OFF delay time ⁽²⁾	$I_{LOAD} = 1.4\text{ A}$, resistive load	500	800	1000	ns
$t_{D(off)IN}$	Input to out turn OFF delay time	$I_{LOAD} = 1.4\text{ A}$, resistive load	500	800	1000	ns
t_{FALL}	Output fall time ⁽²⁾	$I_{LOAD} = 1.4\text{ A}$, resistive load	40	-	250	ns

Table 5. Electrical characteristics (continued)

Symbol	Parameter	Test conditions	Min.	Typ.	Max.	Unit
t_{dt}	Dead time protection	-	0.5	1	-	μs
f_{CP}	Charge pump frequency	$-25\text{ }^\circ\text{C} < T_j < 125\text{ }^\circ\text{C}$	-	0.6	1	MHz
Overcurrent detection						
$I_{s\text{ over}}$	Input supply overcurrent detection threshold	$-25\text{ }^\circ\text{C} < T_j < 125\text{ }^\circ\text{C}; R_{CL} = 39\text{ k}\Omega$ $-25\text{ }^\circ\text{C} < T_j < 125\text{ }^\circ\text{C}; R_{CL} = 5\text{ k}\Omega$ $-25\text{ }^\circ\text{C} < T_j < 125\text{ }^\circ\text{C}; R_{CL} = \text{GND}$	-10%	0.29	+10%	A
			-10%	2.21	+10%	
			-30%	2.8	+30%	
ROPDR	Open drain ON resistance	$I = 4\text{ mA}$	-	40	60	Ω
$t_{OCD(ON)}$	OCD turn-on delay time ⁽³⁾	$I = 4\text{ mA}; C_{EN} < 100\text{ pF}$	-	200	-	ns
$t_{OCD(OFF)}$	OCD turn-off delay time ⁽³⁾	$I = 4\text{ mA}; C_{EN} < 100\text{ pF}$	-	100	-	ns

1. Tested at 25 °C in a restricted range and guaranteed by characterization.
2. See [Figure 3](#).
3. See [Figure 4](#).

Figure 3. Switching characteristic definition

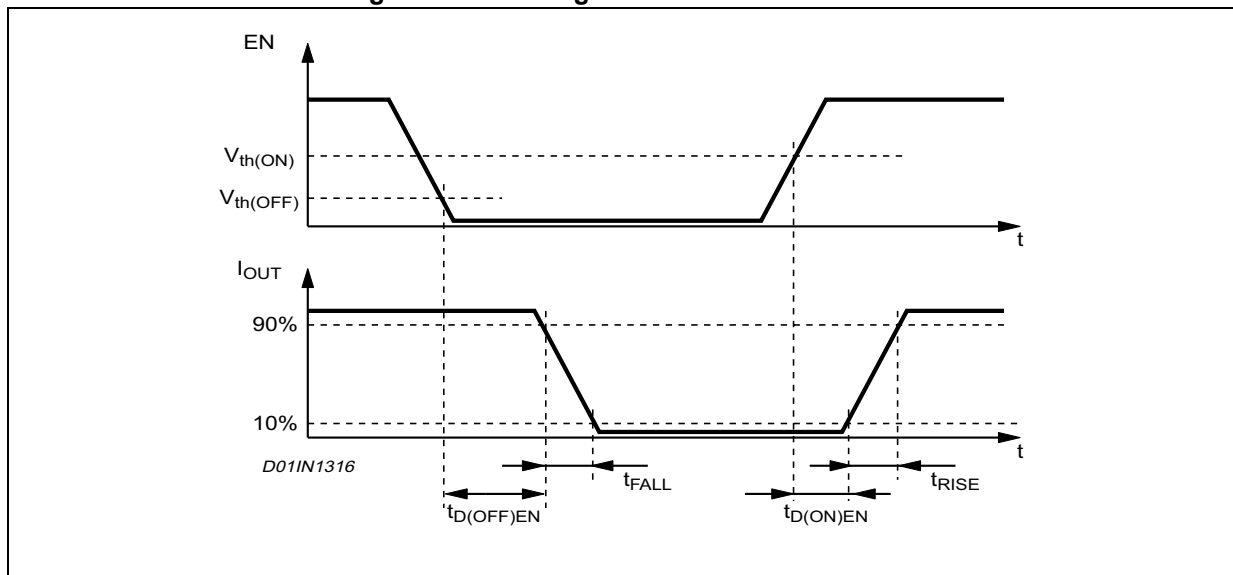
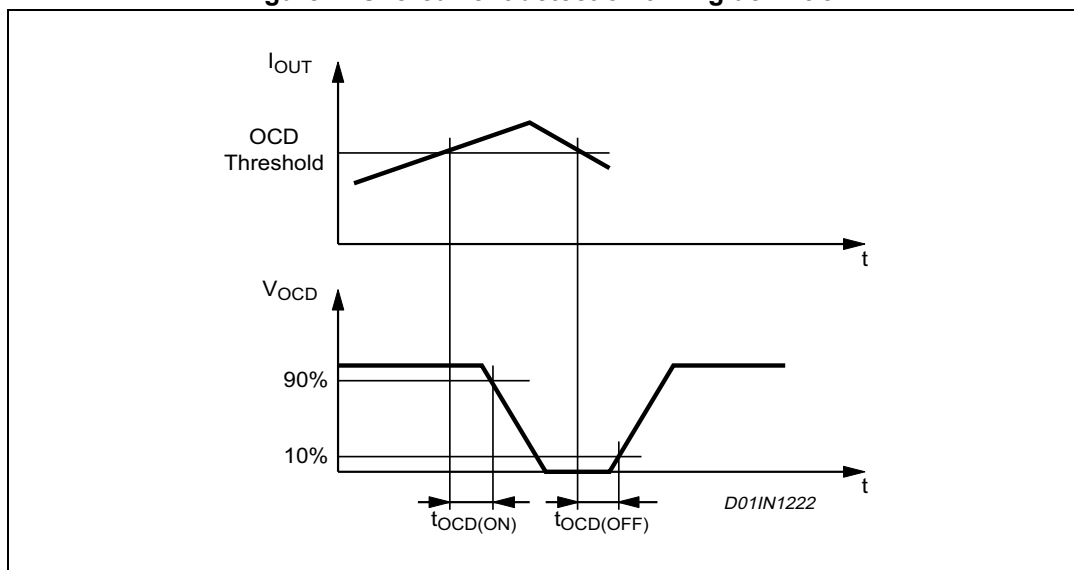

Figure 4. Overcurrent detection timing definition



4 Circuit description

4.1 Power stages and charge pump

The L6226 integrates two independent Power MOS full bridges. Each Power MOS has an $R_{DSon} = 0.73 \Omega$ (typical value at 25 °C), with intrinsic fast freewheeling diode. Cross conduction protection is achieved using a dead time ($t_d = 1 \mu s$ typical) between the switch off and switch on of two Power MOS in one leg of a bridge. Using N-channel power MOS for the upper transistors in the bridge requires a gate drive voltage above the power supply voltage. The Bootstrapped (VBOOT) supply is obtained through an internal oscillator and few external components to realize a charge pump circuit as shown in [Figure 5](#). The oscillator output (VCP) is a square wave at 600 kHz (typical) with 10 V amplitude. Recommended values/part numbers for the charge pump circuit are shown in [Table 6](#).

Table 6. Charge pump external components values

Component	Value
C_{BOOT}	220 nF
C_P	10 nF
D1	1N4148
D2	1N4148

Figure 5. Charge pump circuit

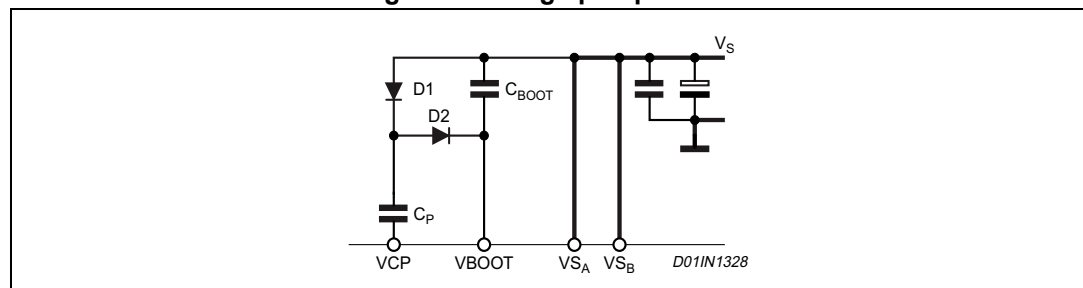

4.2 Logic inputs

Pins IN1A, IN2A, IN1B, IN2B, ENA and ENB are TTL/ CMOS and microcontroller compatible logic inputs. The internal structure is shown in [Figure 4](#). Typical value for turn-on and turn-off thresholds are respectively $V_{thon} = 1.8 V$ and $V_{thoff} = 1.3 V$. Pins ENA and ENB are commonly used to implement Overcurrent and Thermal protection by connecting them respectively to the outputs OCDA and OCDB, which are open-drain outputs. If that type of connection is chosen, some care needs to be taken in driving these pins. Two configurations are shown in [Figure 7](#) and [Figure 8](#). If driven by an open drain (collector) structure, a pull-up resistor REN and a capacitor CEN are connected as shown in [Figure 7](#). If the driver is a standard Push-Pull structure the resistor REN and the capacitor CEN are connected as shown in [Figure 8](#). The resistor REN should be chosen in the range from 2.2 k Ω to 180 k Ω . Recommended values for REN and CEN are respectively 100 k Ω and 5.6 nF. More information on selecting the values is found in the overcurrent protection section.

Figure 6. Logic inputs internal structure

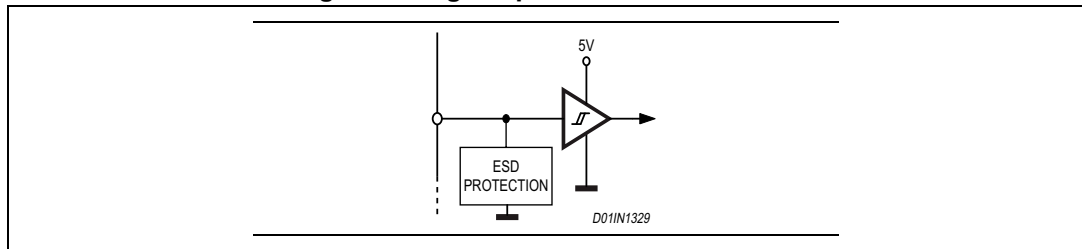

Figure 7. ENA and ENB pins open collector driving

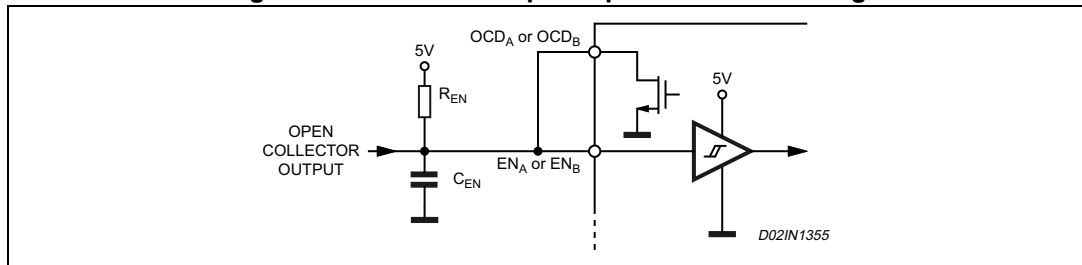

Figure 8. ENA and ENB pins push-pull driving

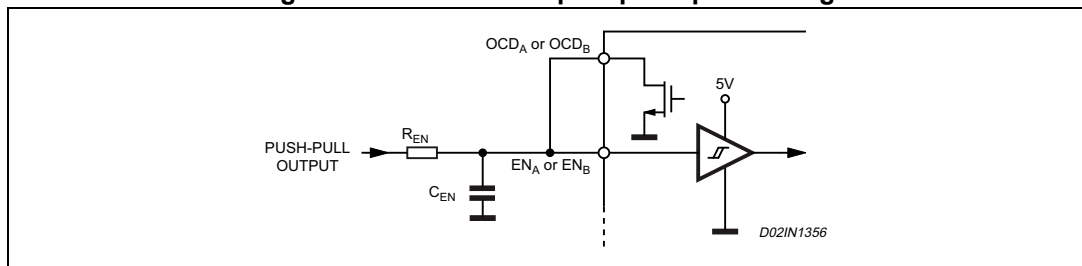

Table 7. Truth table

Inputs			Outputs	
EN	IN1	IN2	OUT1	OUT2
L	X ⁽¹⁾	X	High Z ⁽²⁾	High Z
H	L	L	GND	GND
H	H	L	Vs	GND
H	L	H	GND	Vs
H	H	H	Vs	Vs

1. Don't care.
2. High impedance output.

4.3 Non-dissipative overcurrent detection and protection

An overcurrent detection circuit (OCD) is integrated. This circuit can be used to provide protection against a short-circuit to ground or between two phases of the bridge as well as a rough regulation of the load current. With this internal overcurrent detection, the external current sense resistor normally used and its associated power dissipation are eliminated.

Figure 9 shows a simplified schematic of the overcurrent detection circuit for the Bridge A. Bridge B is provided with an analogous circuit.

To implement the overcurrent detection, a sensing element that delivers a small but precise fraction of the output current is implemented with each high side power MOS. Since this current is a small fraction of the output current there is very little additional power dissipation. This current is compared with an internal reference current I_{REF} . When the output current reaches the detection threshold I_{SOVER} the OCD comparator signals a fault condition. When a fault condition is detected, an internal open drain MOS with a pull down capability of 4 mA connected to the OCD pin is turned on. *Figure 10* shows the OCD operation.

This signal can be used to regulate the output current simply by connecting the OCD pin to the EN pin and adding an external R-C as shown in *Figure 9*. The off time before recovering normal operation can be easily programmed by means of the accurate thresholds of the logic inputs.

I_{REF} and, therefore, the output current detection threshold are selectable by the RCL value, following the equations:

- $I_{SOVER} = 2.8 \text{ A} \pm 30\%$ at $-25 \text{ }^\circ\text{C} < T_j < 125 \text{ }^\circ\text{C}$ if $R_{CL} = 0 \ \Omega$ (PROGCL connected to GND)
- $I_{SOVER} = 11050 / R_{CL} \pm 10\%$ at $-25 \text{ }^\circ\text{C} < T_j < 125 \text{ }^\circ\text{C}$ if $5 \text{ k}\Omega < R_C < 40 \text{ k}\Omega$

Figure 11 shows the output current protection threshold versus R_{CL} value in the range 5 k Ω to 40 k Ω .

The disable time $t_{DISABLE}$ before recovering normal operation can be easily programmed by means of the accurate

thresholds of the logic inputs. It is affected whether by C_{EN} and R_{EN} values and its magnitude is reported in *Figure 12*. The delay time t_{DELAY} before turning off the bridge when an overcurrent has been detected depends only on the C_{EN} value. Its magnitude is reported in *Figure 13*.

C_{EN} is also used for providing immunity to the EN pin against fast transient noises. Therefore the value of C_{EN} should be chosen as big as possible according to the maximum tolerable delay time and the R_{EN} value should be chosen according to the desired disable time.

The resistor R_{EN} should be chosen in the range from 2.2 k Ω to 180 k Ω . Recommended values for R_{EN} and C_{EN} are respectively 100 k Ω and 5.6 nF that allow obtaining 200 μs disable time.

Figure 9. Overcurrent protection simplified schematic

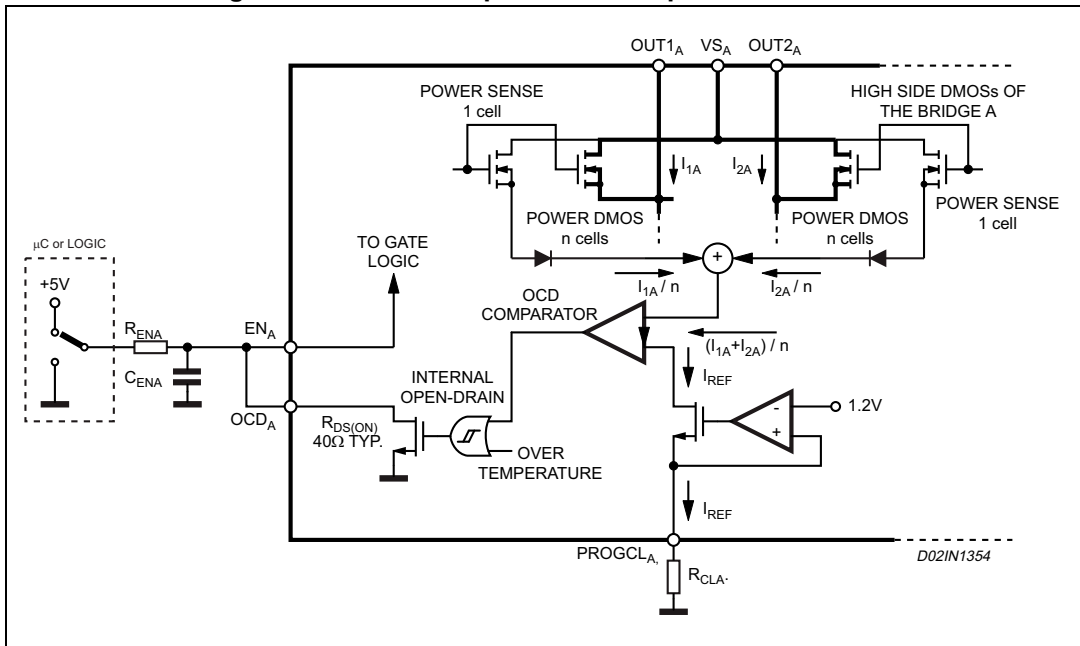

Figure 10. Overcurrent protection waveforms

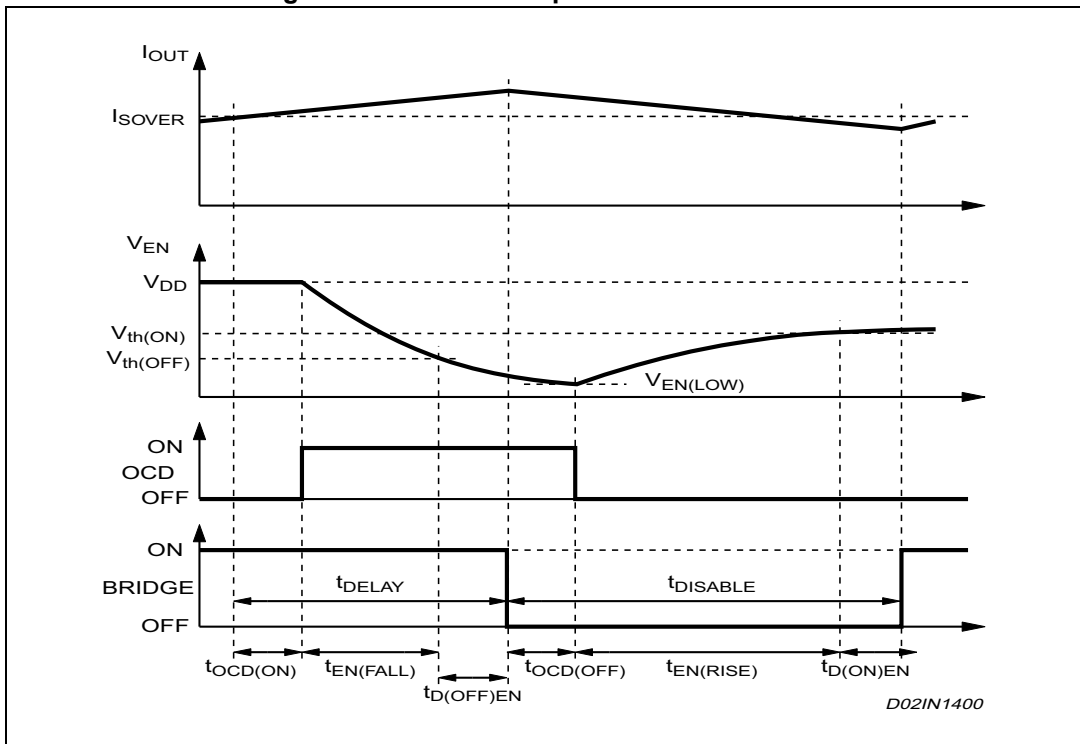

Figure 11. Output current protection threshold versus R_{CL} value

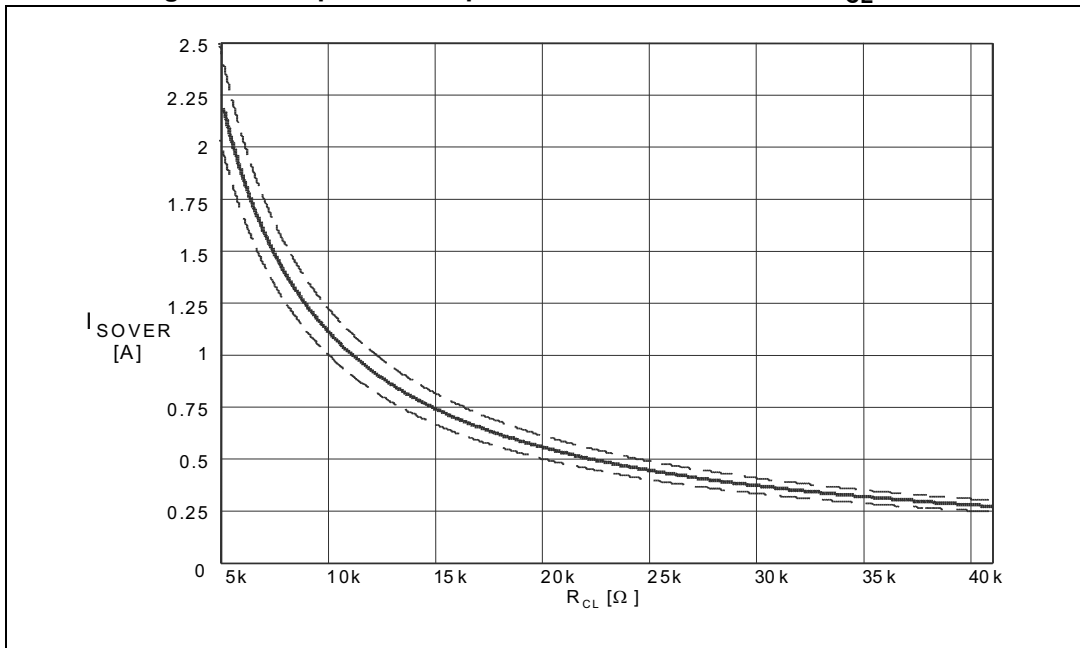

Figure 12. $t_{DISABLE}$ versus C_{EN} and R_{EN} ($V_{DD} = 5 V$)

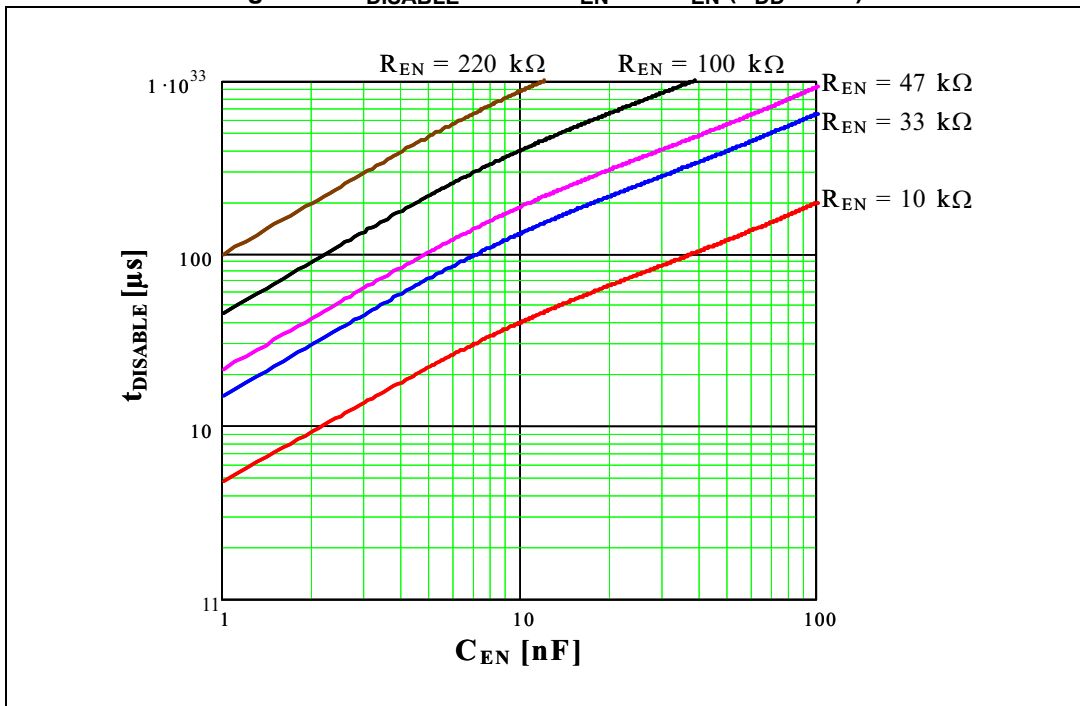
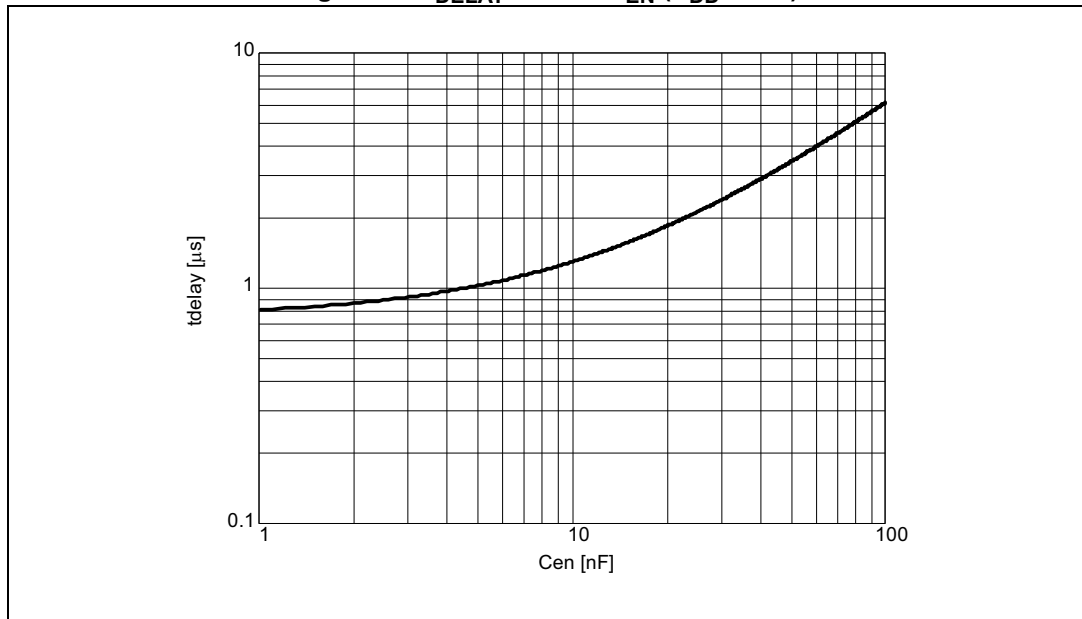

Figure 13. t_{DELAY} versus C_{EN} ($V_{\text{DD}} = 5 \text{ V}$)

4.4 Thermal protection

In addition to the overcurrent detection, the L6226 integrates a thermal protection for preventing the device destruction in case of junction overtemperature. It works sensing the die temperature by means of a sensible element integrated in the die. The device switch-off when the junction temperature reaches 165 °C (typ. value) with 15 °C hysteresis (typ. value).

5 Application information

A typical application using L6226 is shown in [Figure 14](#). Typical component values for the application are shown in [Figure 8](#). A high quality ceramic capacitor in the range of 100 to 200 nF should be placed between the power pins (VS_A and VS_B) and ground near the L6226 to improve the high frequency filtering on the power supply and reduce high frequency transients generated by the switching. The capacitors connected from the EN_A/OCD_A and EN_B/OCD_B nodes to ground set the shut down time for the Bridge A and Bridge B respectively when an over current is detected (see overcurrent protection). The two current sources ($SENSE_A$ and $SENSE_B$) should be connected to power ground with a trace length as short as possible in the layout. To increase noise immunity, unused logic pins are best connected to 5 V (high logic level) or GND (low logic level) (see pin description).

It is recommended to keep power ground and signal ground separated on PCB.

Table 8. Component values for typical application

Component	Value	Component	Value
C_1	100 μ F	D_1	1N4148
C_2	100 nF	D_2	1N4148
C_{BOOT}	220 nF	R_{CLA}	5 k Ω
C_P	10 nF	R_{CLB}	5 k Ω
C_{ENA}	5.6 nF	R_{ENA}	100 k Ω
C_{ENB}	5.6 nF	R_{ENB}	100 k Ω
C_{REF}	68 nF	-	-

Figure 14. Typical application

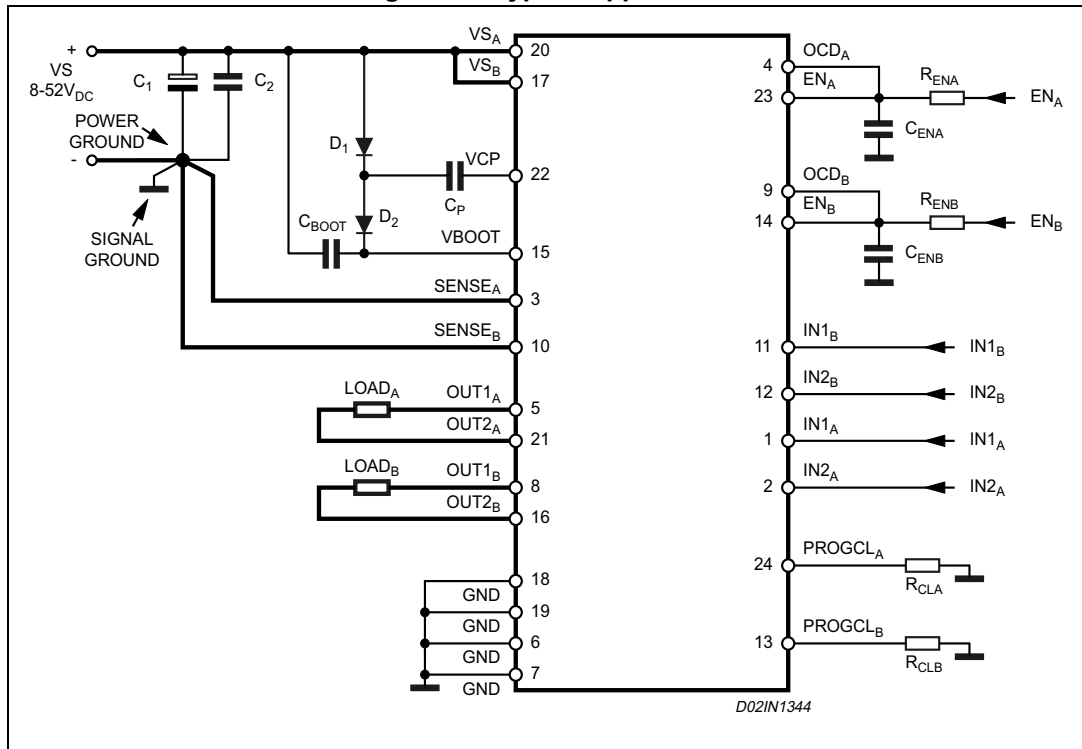

6 Paralleled operation

The outputs of the L6226 can be paralleled to increase the output current capability or reduce the power dissipation in the device at a given current level. It must be noted, however, that the internal wire bond connections from the die to the power or sense pins of the package must carry current in both of the associated half bridges. When the two halves of one full bridge (for example OUT1A and OUT2A) are connected in parallel, the peak current rating is not increased since the total current must still flow through one bond wire on the power supply or sense pin. In addition the overcurrent detection senses the sum of the current in the upper devices of each bridge (A or B) so connecting the two halves of one bridge in parallel does not increase the over current detection threshold.

For most applications the recommended configuration is half bridge 1 of bridge A paralleled with the half bridge 1 of the bridge B, and the same for the half bridges 2 as shown in [Figure 15](#). The current in the two devices connected in parallel will share very well since the $R_{DS(ON)}$ of the devices on the same die is well matched.

When connected in this configuration the over current detection circuit, which senses the current in each bridge (A and B), will sense the current in upper devices connected in parallel independently and the sense circuit with the lowest threshold will trip first. With the enables connected in parallel, the first detection of an over current in either upper DMOS device will turn of both bridges. Assuming that the two DMOS devices share the current equally, the resulting over current detection threshold will be twice the minimum threshold set by the resistors R_{CLA} or R_{CLB} in [Figure 15](#). It is recommended to use $R_{CLA} = R_{CLB}$.

In this configuration the resulting Bridge has the following characteristics.

- Equivalent device: full bridge
- $R_{DS(ON)}$ 0.37 Ω typ. value at $T_J = 25^\circ\text{C}$
- 2.8 A max. RMS load current
- 5.6 A max. OCD threshold

Figure 15. Parallel connection for higher current

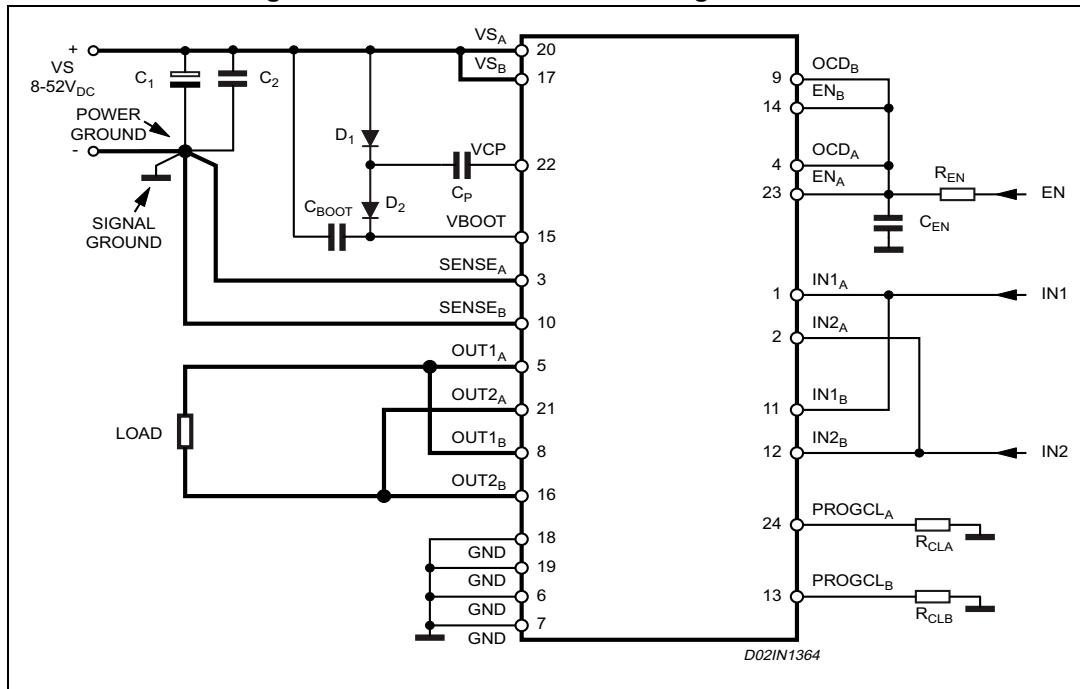

To operate the device in parallel and maintain a lower overcurrent threshold, half bridge 1 and the half bridge 2 of the bridge A can be connected in parallel and the same done for the bridge B as shown in [Figure 16](#). In this configuration, the peak current for each half bridge is still limited by the bond wires for the supply and sense pins so the dissipation in the device will be reduced, but the peak current rating is not increased.

When connected in this configuration the overcurrent detection circuit, senses the sum of the current in upper devices connected in parallel. With the enables connected in parallel, an over current will turn of both bridges.

Since the circuit senses the total current in the upper devices, the overcurrent threshold is equal to the threshold set the resistor R_{CLA} or R_{CLB} in [Figure 16](#). R_{CLA} sets the threshold when outputs OUT1A and OUT2A are high and resistor R_{CLB} sets the threshold when outputs OUT1B and OUT2B are high.

It is recommended to use $R_{CLA} = R_{CLB}$.

In this configuration, the resulting bridge has the following characteristics.

- Equivalent device: full bridge
- $R_{DS(ON)}$ 0.37 Ω typ. value at $T_J = 25\text{ }^\circ\text{C}$
- 1.4 A max. RMS load current
- 2.8 A max. OCD threshold

Figure 16. Parallel connection with lower overcurrent threshold

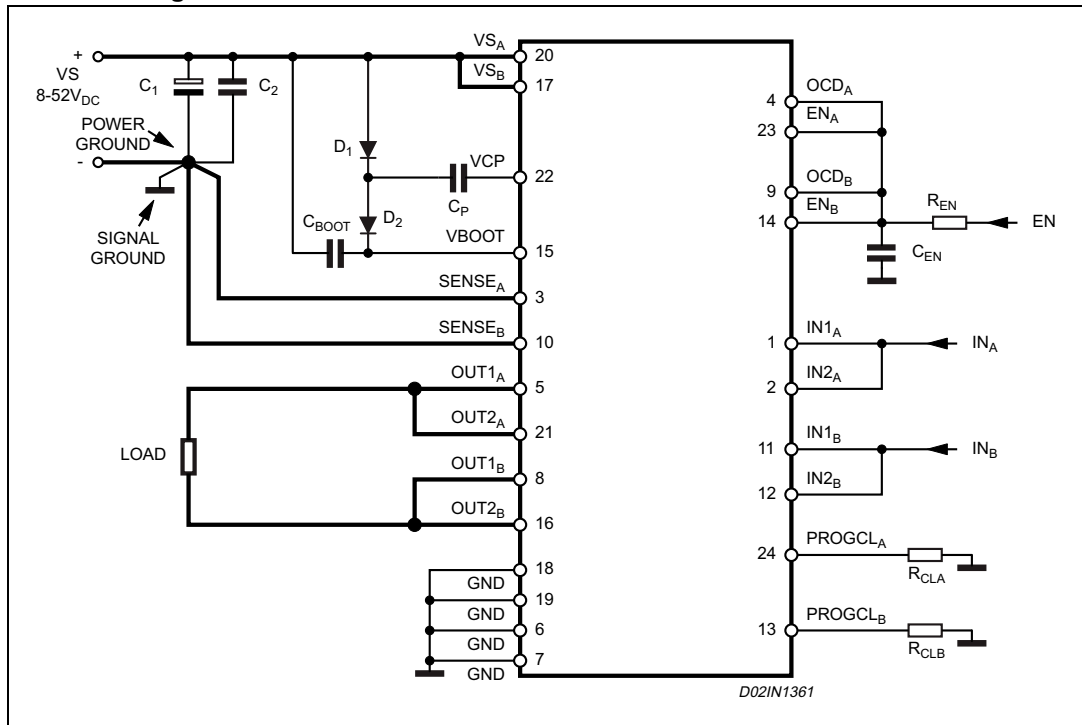

It is also possible to parallel the four half bridges to obtain a simple half bridge as shown in [Figure 17](#). In this configuration the, the overcurrent threshold is equal to twice the minimum threshold set by the resistors R_{CLA} or R_{CLB} in [Figure 17](#). It is recommended to use $R_{CLA} = R_{CLB}$.

The resulting half bridge has the following characteristics.

- Equivalent device: half bridge
- $R_{DS(ON)}$ 0.18 Ω typ. value at $T_J = 25^\circ C$
- 2.8 A max RMS load current
- 5.6 A max OCD threshold

Figure 17. Paralleling the four half bridges

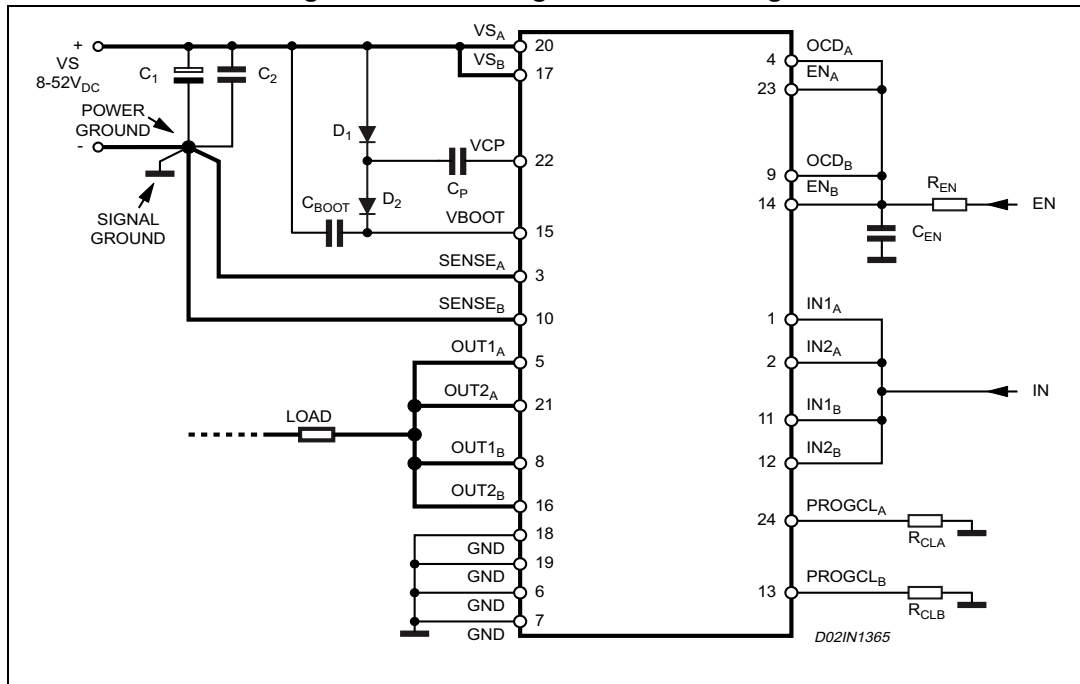

Output current capability and IC power dissipation

In [Figure 18](#) and [Figure 19](#) are shown the approximate relation between the output current and the IC power dissipation using PWM current control driving two loads, for two different driving types:

- One full bridge ON at a time ([Figure 18](#)) in which only one load at a time is energized.
- Two full bridges ON at the same time ([Figure 19](#)) in which two loads at the same time are energized.

For a given output current and driving type the power dissipated by the IC can be easily evaluated, in order to establish which package should be used and how large must be the on-board copper dissipating area to guarantee a safe operating junction temperature (125 °C maximum).

Figure 18. IC power dissipation versus output current with one full bridge ON at a time

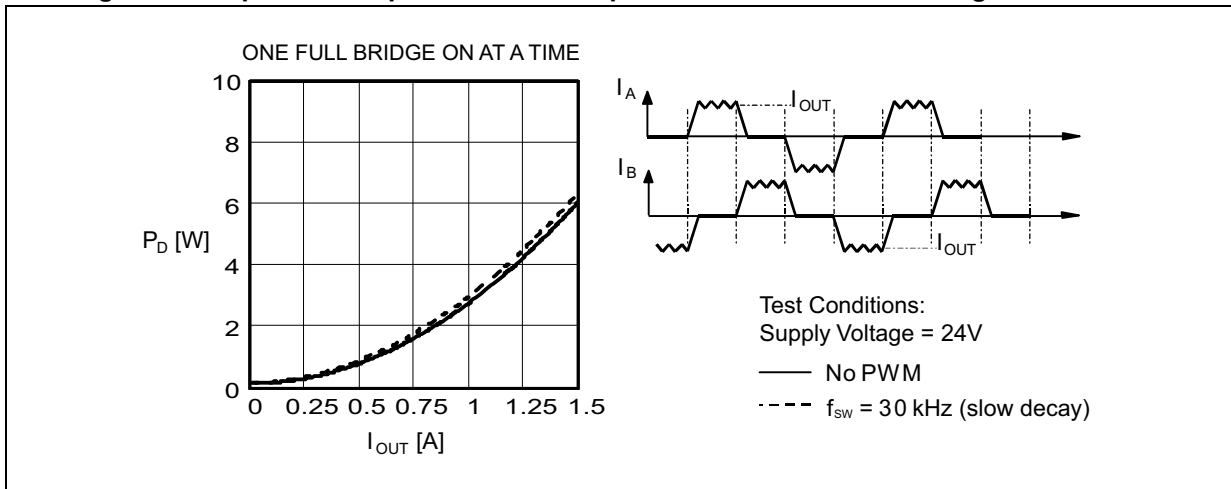
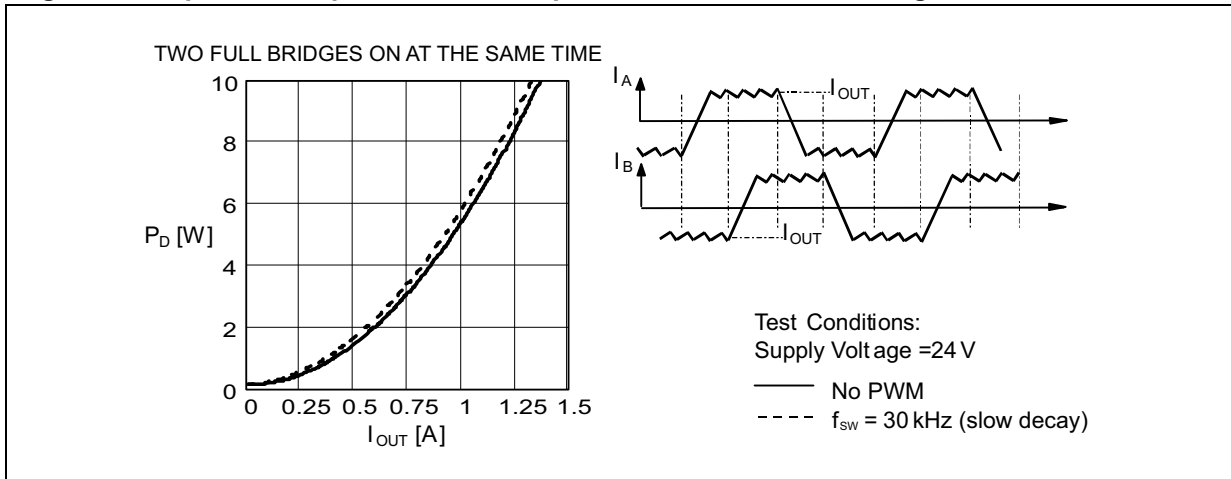

Figure 19. IC power dissipation versus output current with two full bridges ON at the same time



7 Thermal management

In most applications the power dissipation in the IC is the main factor that sets the maximum current that can be delivered by the device in a safe operating condition. Therefore, it has to be taken into account very carefully. Besides the available space on the PCB, the right package should be chosen considering the power dissipation. Heat sinking can be achieved using copper on the PCB with proper area and thickness. *Figure 21* and *22* show the junction-to-ambient thermal resistance values for the PowerSO36 and SO24 packages.

For instance, using a PowerSO package with copper slug soldered on a 1.5 mm copper thickness FR4 board with 6 cm² dissipating footprint (copper thickness of 35 μm), the R_{thJA} is about 35 °C/W. *Figure 20* shows mounting methods for this package. Using a multi-layer board with vias to a ground plane, thermal impedance can be reduced down to 15 °C/W.

Figure 20. Mounting the PowerSO package

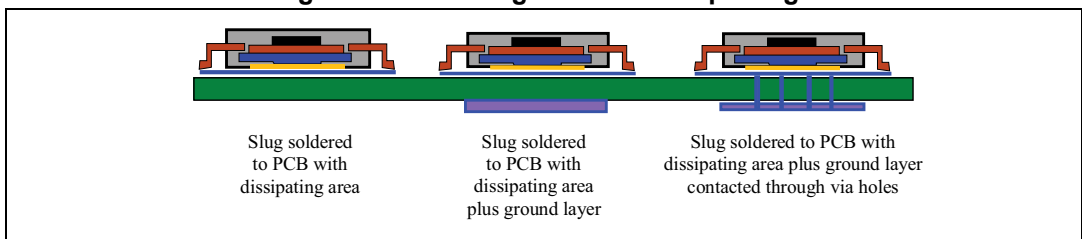

Figure 21. PowerSO36 junction-amb. thermal resistance vs on-board copper area

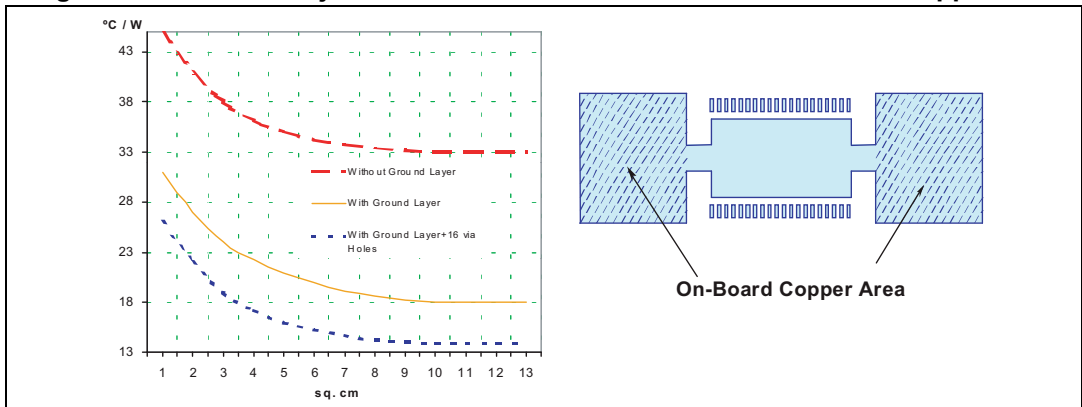
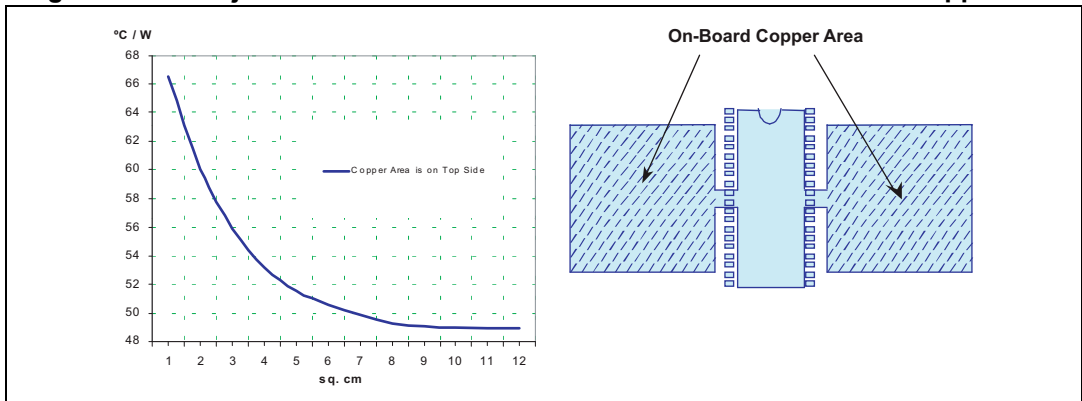

Figure 22. SO24 junction-ambient thermal resistance versus on-board copper area



8 Package information

In order to meet environmental requirements, ST offers these devices in different grades of ECOPACK® packages, depending on their level of environmental compliance. ECOPACK® specifications, grade definitions and product status are available at: www.st.com. ECOPACK is an ST trademark.

8.1 PowerSO36 package information

Figure 23. PowerSO36 package outline

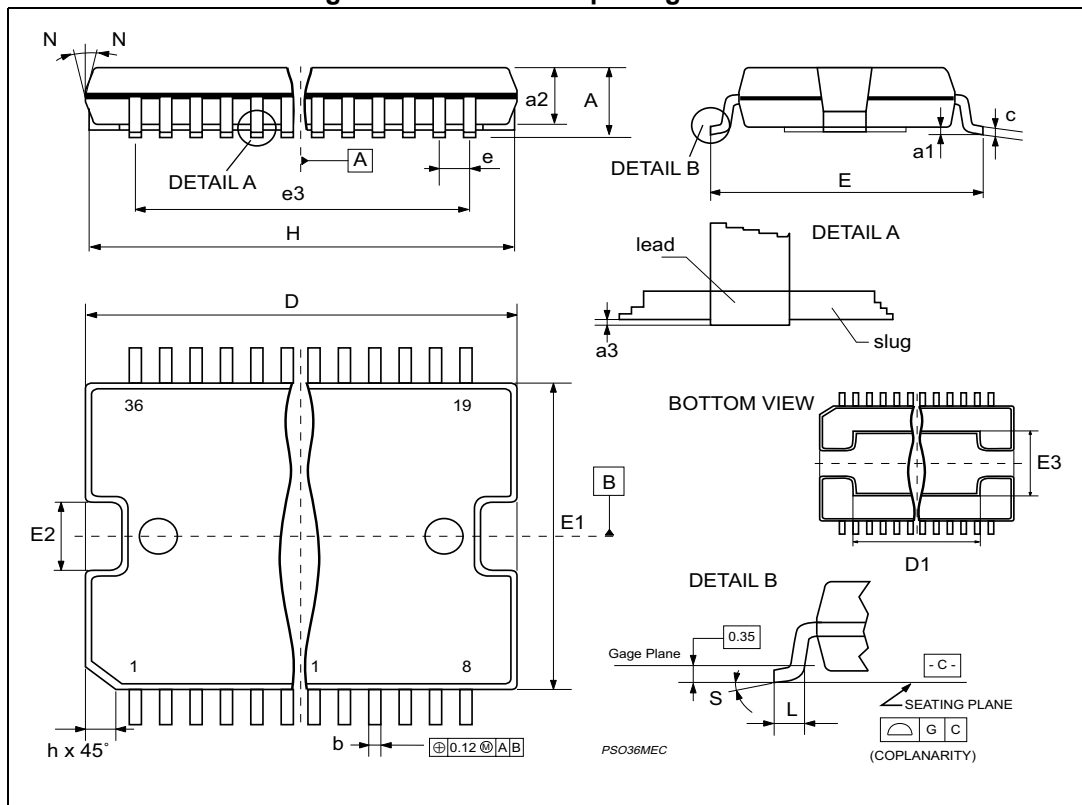

Table 9. PowerSO36 package mechanical data

Symbol	Dimensions (mm)		
	Min.	Typ.	Max.
A	-	-	3.60
a1	0.10	-	0.30
a2	-	-	3.30
a3	0	-	0.10
b	0.22	-	0.38
c	0.23	-	0.32
D (1)	15.80	-	16.00
D1	9.40	-	9.80
E	13.90	-	14.50
e	-	0.65	-
e3	-	11.05	-
E1 (1)	10.90	-	11.10
E2	-	-	2.90
E3	5.80	-	6.20
E4	2.90	-	3.20
G	0	-	0.10
H	15.50	-	15.90
h	-	-	1.10
L	0.80	-	1.10
N	10°(max.)	-	-
S	8 °(max.)	-	-

8.2 SO24 package information

Figure 24. SO24 package outline

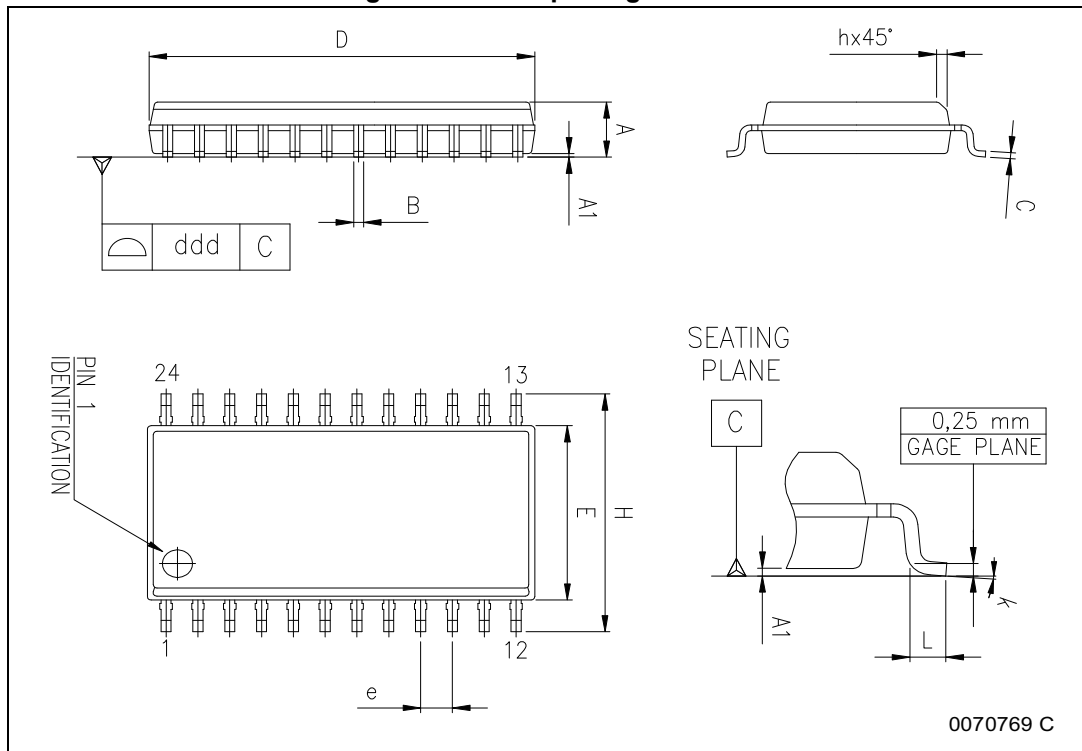

Table 10. SO24 package mechanical data

Symbol	Dimensions					
	mm			inch		
	Min.	Typ.	Max.	Min.	Typ.	Max.
A	2.35	-	2.65	0.093	-	0.104
A1	0.10	-	0.30	0.004	-	0.012
B	0.33	-	0.51	0.013	-	0.020
C	0.23	-	0.32	0.009	-	0.013
D	15.20	-	15.60	0.598	-	0.614
E	7.40	-	7.60	0.291	-	0.299
e	-	1.27	-	-	0.050	-
H	10.0	-	10.65	0.394	-	0.419
h	0.25	-	0.75	0.010	-	0.030
L	0.40	-	1.27	0.016	-	0.050
k	0° (min.), 8° (max.)					
ddd	-	-	0.10	-	-	0.004

9 Ordering codes

Table 11. Ordering information

Order codes	Package	Packing
L6226PD	PowerSO36	Tube
L6226D	SO24	

10 Revision history

Table 12. Document revision history

Date	Revision	Changes
Sep-2003	1	Initial release
04-Mar-2008	2	Minor revision due to revalidation process, no content change
29-Sep-2009	3	Updated <i>Table 1 on page 3</i>
21-Oct-2009	4	Updated <i>Figure 4 on page 9</i>
03-Oct-2018	5	Removed PowerDIP24 package from the whole document. Removed "T _j " from Table 2 on page 3 . Minor modifications throughout document.

IMPORTANT NOTICE – PLEASE READ CAREFULLY

STMicroelectronics NV and its subsidiaries (“ST”) reserve the right to make changes, corrections, enhancements, modifications, and improvements to ST products and/or to this document at any time without notice. Purchasers should obtain the latest relevant information on ST products before placing orders. ST products are sold pursuant to ST’s terms and conditions of sale in place at the time of order acknowledgement.

Purchasers are solely responsible for the choice, selection, and use of ST products and ST assumes no liability for application assistance or the design of Purchasers’ products.

No license, express or implied, to any intellectual property right is granted by ST herein.

Resale of ST products with provisions different from the information set forth herein shall void any warranty granted by ST for such product.

ST and the ST logo are trademarks of ST. All other product or service names are the property of their respective owners.

Information in this document supersedes and replaces information previously supplied in any prior versions of this document.

© 2018 STMicroelectronics – All rights reserved

Looking for pricing, stock, or lifecycle information?

Click below to explore more details on WIN SOURCE:

 [View L6226D](#) on WIN SOURCE

 [STMicroelectronics](#) Information

Optimize Your Supply Chain with WIN SOURCE Solutions

-  Global Sourcing Solution
-  Obsolete Management
-  Cost Control Management
-  Shortage Management
-  Alternative Solution
-  Excess Inventory Management