



**THE DATASHEET OF
ADG1608BRUZ-REEL7**





FEATURES

- 4.5 Ω typical on resistance
- 1 Ω on-resistance flatness
- Up to 470 mA continuous current
- ± 3.3 V to ± 8 V dual-supply operation
- 3.3 V to 16 V single-supply operation
- No V_L supply required
- 3 V logic-compatible inputs
- Rail-to-rail operation
- 16-lead TSSOP and 16-lead, 3 mm \times 3 mm LFCSP

APPLICATIONS

- Communication systems
- Medical systems
- Audio signal routing
- Video signal routing
- Automatic test equipment
- Data acquisition systems
- Battery-powered systems
- Sample-and-hold systems
- Relay replacements

GENERAL DESCRIPTION

The ADG1608/ADG1609 are monolithic CMOS analog multiplexers comprising eight single channels and four differential channels, respectively. The ADG1608 switches one of eight inputs to a common output, as determined by the 3-bit binary address lines, A0, A1, and A2. The ADG1609 switches one of four differential inputs to a common differential output, as determined by the 2-bit binary address lines, A0 and A1. An EN input on both devices is used to enable or disable the device. When disabled, all channels are switched off.

Each switch conducts equally well in both directions when on and has an input signal range that extends to the supplies. In the off condition, signal levels up to the supplies are blocked. All switches exhibit break-before-make switching action. Inherent in the design is low charge injection for minimum transients when switching the digital inputs.

FUNCTIONAL BLOCK DIAGRAMS

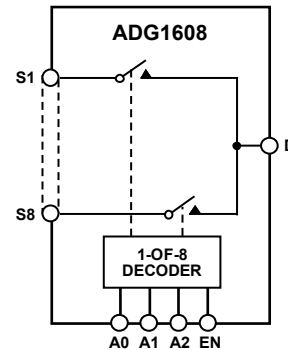

Figure 1.

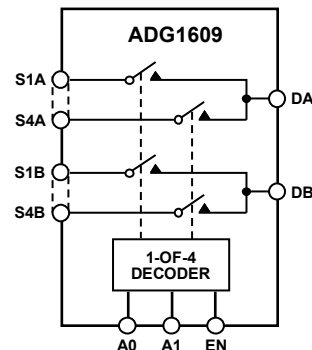

Figure 2.

The low on resistance of these switches make them ideal solutions for data acquisition and gain switching applications where low on resistance and distortion is critical. The on-resistance profile is very flat over the full analog input range, ensuring excellent linearity and low distortion when switching audio signals.

CMOS construction ensures ultralow power dissipation, making the parts ideally suited for portable and battery-powered instruments.

PRODUCT HIGHLIGHTS

- 8 Ω maximum on resistance over temperature.
- Minimum distortion: THD + N = 0.04%
- 3 V logic-compatible digital inputs: $V_{INH} = 2.0$ V, $V_{INL} = 0.8$ V.
- No V_L logic power supply required.
- Ultralow power dissipation: <8 nW.
- 16-lead TSSOP and 16-lead, 3 mm \times 3 mm LFCSP.

Rev. A

[Document Feedback](#)

Information furnished by Analog Devices is believed to be accurate and reliable. However, no responsibility is assumed by Analog Devices for its use, nor for any infringements of patents or other rights of third parties that may result from its use. Specifications subject to change without notice. No license is granted by implication or otherwise under any patent or patent rights of Analog Devices. Trademarks and registered trademarks are the property of their respective owners.

TABLE OF CONTENTS

Features	1	Continuous Current per Channel, S or D	7
Applications	1	Absolute Maximum Ratings	8
Functional Block Diagrams	1	ESD Caution	8
General Description	1	Pin Configurations and Function Descriptions	9
Product Highlights	1	Typical Performance Characteristics	11
Revision History	2	Test Circuits	14
Specifications	3	Terminology	17
±5 V Dual Supply	3	Outline Dimensions	18
12 V Single Supply	4	Ordering Guide	18
5 V Single Supply	5		
3.3 V Single Supply	6		

REVISION HISTORY

9/15—Rev. 0 to Rev. A	
Change to Table 7	8
Updated Outline Dimensions	18

7/09—Revision 0: Initial Version

SPECIFICATIONS

±5 V DUAL SUPPLY

$V_{DD} = +5\text{ V} \pm 10\%$, $V_{SS} = -5\text{ V} \pm 10\%$, $GND = 0\text{ V}$, unless otherwise noted.

Table 1.

Parameter	25°C	-40°C to +85°C	-40°C to +125°C	Unit	Test Conditions/Comments
ANALOG SWITCH					
Analog Signal Range			V_{DD} to V_{SS}	V	
On Resistance (R_{ON})	4.5			Ω typ	$V_S = \pm 4.5\text{ V}$, $I_S = -10\text{ mA}$; see Figure 25
	5	7	8	Ω max	$V_{DD} = \pm 4.5\text{ V}$, $V_{SS} = \pm 4.5\text{ V}$
On-Resistance Match Between Channels (ΔR_{ON})	0.12			Ω typ	$V_S = \pm 4.5\text{ V}$, $I_S = -10\text{ mA}$
	0.25	0.3	0.35	Ω max	
On-Resistance Flatness ($R_{FLAT(ON)}$)	1			Ω typ	$V_S = \pm 4.5\text{ V}$, $I_S = -10\text{ mA}$
	1.3	1.7	2	Ω max	
LEAKAGE CURRENTS					
Source Off Leakage, I_S (Off)	± 0.02			nA typ	$V_{DD} = +5.5\text{ V}$, $V_{SS} = -5.5\text{ V}$
	± 0.1	± 0.5	± 3	nA max	$V_S = \pm 4.5\text{ V}$, $V_D = \mp 4.5\text{ V}$; see Figure 26
Drain Off Leakage, I_D (Off)	± 0.03			nA typ	$V_S = \pm 4.5\text{ V}$, $V_D = \mp 4.5\text{ V}$; see Figure 26
ADG1608	± 0.15	± 2	± 14	nA max	
ADG1609	± 0.15	± 1	± 7	nA max	
Channel On Leakage, I_D , I_S (On)	± 0.03			nA typ	$V_S = V_D = \pm 4.5\text{ V}$; see Figure 27
	± 0.15	± 2	± 14	nA max	
DIGITAL INPUTS					
Input High Voltage, V_{INH}			2.0	V min	
Input Low Voltage, V_{INL}			0.8	V max	
Input Current, I_{INL} or I_{INH}	± 1			nA typ	$V_{IN} = V_{GND}$ or V_{DD}
			± 0.1	μA max	
Digital Input Capacitance, C_{IN}	4			pF typ	
DYNAMIC CHARACTERISTICS¹					
Transition Time, $t_{TRANSITION}$	150			ns typ	$R_L = 300\ \Omega$, $C_L = 35\text{ pF}$
	182	230	258	ns max	$V_S = 2.5\text{ V}$; see Figure 28
t_{ON} (EN)	106			ns typ	$R_L = 300\ \Omega$, $C_L = 35\text{ pF}$
	132	150	160	ns max	$V_S = 2.5\text{ V}$; see Figure 30
t_{OFF} (EN)	113			ns typ	$R_L = 300\ \Omega$, $C_L = 35\text{ pF}$
	144	178	202	ns max	$V_S = 2.5\text{ V}$; see Figure 30
Break-Before-Make Time Delay, t_D	47			ns typ	$R_L = 300\ \Omega$, $C_L = 35\text{ pF}$
			30	ns min	$V_{S1} = V_{S2} = 2.5\text{ V}$; see Figure 29
Charge Injection	24			pC typ	$V_S = 0\text{ V}$, $R_S = 0\ \Omega$, $C_L = 1\text{ nF}$; see Figure 31
Off Isolation	-64			dB typ	$R_L = 50\ \Omega$, $C_L = 5\text{ pF}$, $f = 1\text{ MHz}$; see Figure 32
Channel-to-Channel Crosstalk	-64			dB typ	$R_L = 50\ \Omega$, $C_L = 5\text{ pF}$, $f = 1\text{ MHz}$; see Figure 34
Total Harmonic Distortion + Noise (THD + N)	0.04			% typ	$R_L = 110\ \Omega$, $V_S = 5\text{ V}$ p-p, $f = 20\text{ Hz}$ to 20 kHz ; see Figure 35
-3 dB Bandwidth					$R_L = 50\ \Omega$, $C_L = 5\text{ pF}$; see Figure 33
ADG1608	40			MHz typ	
ADG1609	71			MHz typ	
C_S (Off)	20			pF typ	$V_S = 0\text{ V}$, $f = 1\text{ MHz}$
C_D (Off)					
ADG1608	120			pF typ	$V_S = 0\text{ V}$, $f = 1\text{ MHz}$
ADG1609	61			pF typ	$V_S = 0\text{ V}$, $f = 1\text{ MHz}$
C_D , C_S (On)					
ADG1608	153			pF typ	$V_S = 0\text{ V}$, $f = 1\text{ MHz}$
ADG1609	85			pF typ	$V_S = 0\text{ V}$, $f = 1\text{ MHz}$
POWER REQUIREMENTS					
I_{DD}	0.001			μA typ	$V_{DD} = +5.5\text{ V}$, $V_{SS} = -5.5\text{ V}$
			1.0	μA max	Digital inputs = 0 V or V_{DD}
V_{DD}/V_{SS}			$\pm 3.3/\pm 8$	V min/max	

¹ Guaranteed by design, but not subject to production test.

12 V SINGLE SUPPLY

$V_{DD} = 12\text{ V} \pm 10\%$, $V_{SS} = 0\text{ V}$, $GND = 0\text{ V}$, unless otherwise noted.

Table 2.

Parameter	25°C	-40°C to +85°C	-40°C to +125°C	Unit	Test Conditions/Comments
ANALOG SWITCH					
Analog Signal Range			0 V to V_{DD}	V	
On Resistance (R_{ON})	4			Ω typ	$V_S = 0\text{ V}$ to 10 V , $I_S = -10\text{ mA}$; see Figure 25
	4.5	6.5	7.5	Ω max	$V_{DD} = 10.8\text{ V}$, $V_{SS} = 0\text{ V}$
On-Resistance Match Between Channels (ΔR_{ON})	0.12			Ω typ	$V_S = 10\text{ V}$, $I_S = -10\text{ mA}$
	0.25	0.3	0.35	Ω max	
On-Resistance Flatness ($R_{FLAT(ON)}$)	0.9			Ω typ	$V_S = 0\text{ V}$ to 10 V , $I_S = -10\text{ mA}$
	1.2	1.6	1.9	Ω max	
LEAKAGE CURRENTS					
Source Off Leakage, I_S (Off)	± 0.02			nA typ	$V_{DD} = 13.2\text{ V}$, $V_{SS} = 0\text{ V}$
	± 0.1	± 0.5	± 3	nA max	$V_S = 1\text{ V}/10\text{ V}$, $V_D = 10\text{ V}/1\text{ V}$; see Figure 26
Drain Off Leakage, I_D (Off)	± 0.03			nA typ	$V_S = 1\text{ V}/10\text{ V}$, $V_D = 10\text{ V}/1\text{ V}$; see Figure 26
ADG1608	± 0.15	± 2	± 14	nA max	
ADG1609	± 0.15	± 1	± 7	nA max	
Channel On Leakage, I_D , I_S (On)	± 0.03			nA typ	$V_S = V_D = 1\text{ V}$ or 10 V ; see Figure 27
	± 0.15	± 2	± 14	nA max	
DIGITAL INPUTS					
Input High Voltage, V_{INH}			2.0	V min	
Input Low Voltage, V_{INL}			0.8	V max	
Input Current, I_{INL} or I_{INH}	± 1			nA typ	$V_{IN} = V_{GND}$ or V_{DD}
			± 0.1	μA max	
Digital Input Capacitance, C_{IN}	4			pF typ	
DYNAMIC CHARACTERISTICS¹					
Transition Time, $t_{TRANSITION}$	113			ns typ	$R_L = 300\ \Omega$, $C_L = 35\text{ pF}$
	141	172	196	ns max	$V_S = 8\text{ V}$; see Figure 28
t_{ON} (EN)	80			ns typ	$R_L = 300\ \Omega$, $C_L = 35\text{ pF}$
	94	101	110	ns max	$V_S = 8\text{ V}$; see Figure 30
t_{OFF} (EN)	77			ns typ	$R_L = 300\ \Omega$, $C_L = 35\text{ pF}$
	93	117	140	ns max	$V_S = 8\text{ V}$; see Figure 30
Break-Before-Make Time Delay, t_D	47			ns typ	$R_L = 300\ \Omega$, $C_L = 35\text{ pF}$
			30	ns min	$V_{S1} = V_{S2} = 8\text{ V}$; see Figure 29
Charge Injection	29			pC typ	$V_S = 6\text{ V}$, $R_S = 0\ \Omega$, $C_L = 1\text{ nF}$; see Figure 31
Off Isolation	-64			dB typ	$R_L = 50\ \Omega$, $C_L = 5\text{ pF}$, $f = 1\text{ MHz}$; see Figure 32
Channel-to-Channel Crosstalk	-64			dB typ	$R_L = 50\ \Omega$, $C_L = 5\text{ pF}$, $f = 1\text{ MHz}$; see Figure 34
Total Harmonic Distortion + Noise (THD + N)	0.04			% typ	$R_L = 110\ \Omega$, $V_S = 5\text{ V}$ p-p, $f = 20\text{ Hz}$ to 20 kHz ; see Figure 35
-3 dB Bandwidth					$R_L = 50\ \Omega$, $C_L = 5\text{ pF}$; see Figure 33
ADG1608	40			MHz typ	
ADG1609	78			MHz typ	
C_S (Off)	19			pF typ	$V_S = 6\text{ V}$, $f = 1\text{ MHz}$
C_D (Off)					
ADG1608	117			pF typ	$V_S = 6\text{ V}$, $f = 1\text{ MHz}$
ADG1609	59			pF typ	$V_S = 6\text{ V}$, $f = 1\text{ MHz}$
C_D , C_S (On)					
ADG1608	149			pF typ	$V_S = 6\text{ V}$, $f = 1\text{ MHz}$
ADG1609	84			pF typ	$V_S = 6\text{ V}$, $f = 1\text{ MHz}$
POWER REQUIREMENTS					
I_{DD}	0.001			μA typ	$V_{DD} = 12\text{ V}$
			1.0	μA max	Digital inputs = 0 V or V_{DD}
ADG1608	300			μA typ	Digital inputs = 5 V
			480	μA max	
ADG1609	225			μA typ	Digital inputs = 5 V
			360	μA max	
V_{DD}			3.3/16	V min/max	

¹ Guaranteed by design, but not subject to production test.

5 V SINGLE SUPPLY

$V_{DD} = 5\text{ V} \pm 10\%$, $V_{SS} = 0\text{ V}$, $GND = 0\text{ V}$, unless otherwise noted.

Table 3.

Parameter	25°C	-40°C to +85°C	-40°C to +125°C	Unit	Test Conditions/Comments
ANALOG SWITCH					
Analog Signal Range			0 V to V_{DD}	V	
On Resistance (R_{ON})	8.5			Ω typ	$V_S = 0\text{ V}$ to 4.5 V, $I_S = -10\text{ mA}$; see Figure 25
	10	12.5	14	Ω max	$V_{DD} = 4.5\text{ V}$, $V_{SS} = 0\text{ V}$
On-Resistance Match Between Channels (ΔR_{ON})	0.15			Ω typ	$V_S = 0\text{ V}$ to 4.5 V, $I_S = -10\text{ mA}$
	0.3	0.35	0.4	Ω max	
On-Resistance Flatness ($R_{FLAT(ON)}$)	1.7			Ω typ	$V_S = 0\text{ V}$ to 4.5 V, $I_S = -10\text{ mA}$
	2.3	2.7	3	Ω max	
LEAKAGE CURRENTS					
Source Off Leakage, I_S (Off)	± 0.01			nA typ	$V_{DD} = 5.5\text{ V}$, $V_{SS} = 0\text{ V}$
	± 0.1	± 0.5	± 3	nA max	$V_S = 1\text{ V}/4.5\text{ V}$, $V_D = 4.5\text{ V}/1\text{ V}$; see Figure 26
Drain Off Leakage, I_D (Off)	± 0.01			nA typ	
ADG1608	± 0.15	± 2	± 14	nA max	$V_S = 1\text{ V}/4.5\text{ V}$, $V_D = 4.5\text{ V}/1\text{ V}$; see Figure 26
ADG1609	± 0.15	± 1	± 7	nA max	
Channel On Leakage, I_D , I_S (On)	± 0.01			nA typ	$V_S = V_D = 1\text{ V}$ or 4.5 V; see Figure 27
	± 0.15	± 2	± 14	nA max	
DIGITAL INPUTS					
Input High Voltage, V_{INH}			2.0	V min	
Input Low Voltage, V_{INL}			0.8	V max	
Input Current, I_{INL} or I_{INH}	± 1			nA typ	$V_{IN} = V_{GND}$ or V_{DD}
			± 0.1	μA max	
Digital Input Capacitance, C_{IN}	4			pF typ	
DYNAMIC CHARACTERISTICS¹					
Transition Time, $t_{TRANSITION}$	193			ns typ	$R_L = 300\ \Omega$, $C_L = 35\text{ pF}$
	251	301	339	ns max	$V_S = 2.5\text{ V}$; see Figure 28
t_{ON} (EN)	115			ns typ	$R_L = 300\ \Omega$, $C_L = 35\text{ pF}$
	152	171	184	ns max	$V_S = 2.5\text{ V}$; see Figure 30
t_{OFF} (EN)	140			ns typ	$R_L = 300\ \Omega$, $C_L = 35\text{ pF}$
	184	225	259	ns max	$V_S = 2.5\text{ V}$; see Figure 30
Break-Before-Make Time Delay, t_D	66			ns typ	$R_L = 300\ \Omega$, $C_L = 35\text{ pF}$
			37	ns min	$V_{S1} = V_{S2} = 2.5\text{ V}$; see Figure 29
Charge Injection	11			pC typ	$V_S = 2.5\text{ V}$, $R_S = 0\ \Omega$, $C_L = 1\text{ nF}$; see Figure 31
Off Isolation	-64			dB typ	$R_L = 50\ \Omega$, $C_L = 5\text{ pF}$, $f = 100\text{ kHz}$; see Figure 32
Channel-to-Channel Crosstalk	-64			dB typ	$R_L = 50\ \Omega$, $C_L = 5\text{ pF}$, $f = 100\text{ kHz}$; see Figure 34
Total Harmonic Distortion + Noise (THD + N)	0.3			% typ	$R_L = 110\ \Omega$, $f = 20\text{ Hz}$ to 20 kHz, $V_S = 3.5\text{ V}$ p-p; see Figure 35
-3 dB Bandwidth					$R_L = 50\ \Omega$, $C_L = 5\text{ pF}$; see Figure 33
ADG1608	37			MHz typ	
ADG1609	72			MHz typ	
C_S (Off)	22			pF typ	$V_S = 2.5\text{ V}$, $f = 1\text{ MHz}$
C_D (Off)					$V_S = 2.5\text{ V}$, $f = 1\text{ MHz}$
ADG1608	136			pF typ	
ADG1609	68			pF typ	
C_D , C_S (On)					$V_S = 2.5\text{ V}$, $f = 1\text{ MHz}$
ADG1608	168			pF typ	
ADG1609	94			pF typ	
POWER REQUIREMENTS					
I_{DD}	0.001			μA typ	$V_{DD} = 5.5\text{ V}$
			1.0	μA max	Digital inputs = 0 V or V_{DD}
V_{DD}			3.3/16	V min/max	

¹ Guaranteed by design, but not subject to production test.

3.3 V SINGLE SUPPLY

$V_{DD} = 3.3$ V, $V_{SS} = 0$ V, $GND = 0$ V, unless otherwise noted.

Table 4.

Parameter	25°C	-40°C to +85°C	-40°C to +125°C	Unit	Test Conditions/Comments
ANALOG SWITCH					
Analog Signal Range			0 V to V_{DD}	V	
On Resistance (R_{ON})	13.5	15	16.5	Ω typ	$V_S = 0$ V to V_{DD} , $I_S = -10$ mA; see Figure 25, $V_{DD} = 3.3$ V, $V_{SS} = 0$ V
On-Resistance Match Between Channels (ΔR_{ON})	0.25	0.28	0.3	Ω typ	$V_S = 0$ V to V_{DD} , $I_S = -10$ mA
On-Resistance Flatness ($R_{FLAT(ON)}$)	5	5.5	6.5	Ω typ	$V_S = 0$ V to V_{DD} , $I_S = -10$ mA
LEAKAGE CURRENTS					
Source Off Leakage, I_S (Off)	± 0.01			nA typ	$V_{DD} = 3.6$ V, $V_{SS} = 0$ V
	± 0.1	± 0.5	± 3	nA max	$V_S = 0.6$ V/3 V, $V_D = 3$ V/0.6 V; see Figure 26
Drain Off Leakage, I_D (Off)	± 0.01			nA typ	$V_S = 0.6$ V/3 V, $V_D = 3$ V/0.6 V; see Figure 26
ADG1608	± 0.15	± 2	± 14	nA max	
ADG1609	± 0.15	± 1	± 7	nA max	
Channel On Leakage, I_D, I_S (On)	± 0.01			nA typ	$V_S = V_D = 0.6$ V or 3 V; see Figure 27
	± 0.15	± 2	± 14	nA max	
DIGITAL INPUTS					
Input High Voltage, V_{INH}			2.0	V min	
Input Low Voltage, V_{INL}			0.8	V max	
Input Current, I_{INL} or I_{INH}	± 1			nA typ	$V_{IN} = V_{GND}$ or V_{DD}
			± 0.1	μ A max	
Digital Input Capacitance, C_{IN}	4			pF typ	
DYNAMIC CHARACTERISTICS¹					
Transition Time, $t_{TRANSITION}$	312			ns typ	$R_L = 300 \Omega$, $C_L = 35$ pF
	437	498	542	ns max	$V_S = 1.5$ V; see Figure 28
t_{ON} (EN)	216			ns typ	$R_L = 300 \Omega$, $C_L = 35$ pF
	309	331	344	ns max	$V_S = 1.5$ V; see Figure 30
t_{OFF} (EN)	236			ns typ	$R_L = 300 \Omega$, $C_L = 35$ pF
	316	367	411	ns max	$V_S = 1.5$ V; see Figure 30
Break-Before-Make Time Delay, t_D	104			ns typ	$R_L = 300 \Omega$, $C_L = 35$ pF
			48	ns min	$V_{S1} = V_{S2} = 1.5$ V; see Figure 29
Charge Injection	6			pC typ	$V_S = 1.5$ V, $R_S = 0 \Omega$, $C_L = 1$ nF; see Figure 31
Off Isolation	-64			dB typ	$R_L = 50 \Omega$, $C_L = 5$ pF, $f = 100$ kHz; see Figure 32
Channel-to-Channel Crosstalk	-64			dB typ	$R_L = 50 \Omega$, $C_L = 5$ pF, $f = 100$ kHz; see Figure 34
Total Harmonic Distortion + Noise (THD + N)	0.5			% typ	$R_L = 110 \Omega$, $f = 20$ Hz to 20 kHz, $V_S = 2$ V p-p; see Figure 35
-3 dB Bandwidth					$R_L = 50 \Omega$, $C_L = 5$ pF; see Figure 33
ADG1608	34			MHz typ	
ADG1609	72			MHz typ	
C_S (Off)	23			pF typ	$V_S = 1.5$ V, $f = 1$ MHz
C_D (Off)					$V_S = 1.5$ V, $f = 1$ MHz
ADG1608	145			pF typ	
ADG1609	72			pF typ	
C_D, C_S (On)					$V_S = 1.5$ V, $f = 1$ MHz
ADG1608	173			pF typ	
ADG1609	95			pF typ	
POWER REQUIREMENTS					
I_{DD}	0.001			μ A typ	$V_{DD} = 3.6$ V
			1.0	μ A max	Digital inputs = 0 V or V_{DD}
V_{DD}			3.3/16	V min/max	

¹ Guaranteed by design, but not subject to production test.

CONTINUOUS CURRENT PER CHANNEL, S OR D**Table 5. ADG1608**

Parameter	25°C	85°C	125°C	Unit
CONTINUOUS CURRENT, S OR D				
$V_{DD} = +5\text{ V}, V_{SS} = -5\text{ V}$				
TSSOP ($\theta_{JA} = 112.6^\circ\text{C/W}$)	290	180	100	mA max
LFCSP ($\theta_{JA} = 48.7^\circ\text{C/W}$)	470	255	120	mA max
$V_{DD} = 12\text{ V}, V_{SS} = 0\text{ V}$				
TSSOP ($\theta_{JA} = 112.6^\circ\text{C/W}$)	213	129	73	mA max
LFCSP ($\theta_{JA} = 48.7^\circ\text{C/W}$)	346	185	84	mA max
$V_{DD} = 5\text{ V}, V_{SS} = 0\text{ V}$				
TSSOP ($\theta_{JA} = 112.6^\circ\text{C/W}$)	157	101	63	mA max
LFCSP ($\theta_{JA} = 48.7^\circ\text{C/W}$)	252	150	77	mA max
$V_{DD} = 3.3\text{ V}, V_{SS} = 0\text{ V}$				
TSSOP ($\theta_{JA} = 112.6^\circ\text{C/W}$)	126	87	56	mA max
LFCSP ($\theta_{JA} = 48.7^\circ\text{C/W}$)	206	129	73.5	mA max

Table 6. ADG1609

Parameter	25°C	85°C	125°C	Unit
CONTINUOUS CURRENT, S OR D				
$V_{DD} = +5\text{ V}, V_{SS} = -5\text{ V}$				
TSSOP ($\theta_{JA} = 112.6^\circ\text{C/W}$)	147	98	63	mA max
LFCSP ($\theta_{JA} = 48.7^\circ\text{C/W}$)	245	147	77	mA max
$V_{DD} = 12\text{ V}, V_{SS} = 0\text{ V}$				
TSSOP ($\theta_{JA} = 112.6^\circ\text{C/W}$)	157	101	63	mA max
LFCSP ($\theta_{JA} = 48.7^\circ\text{C/W}$)	255	150	77	mA max
$V_{DD} = 5\text{ V}, V_{SS} = 0\text{ V}$				
TSSOP ($\theta_{JA} = 112.6^\circ\text{C/W}$)	115	80	52	mA max
LFCSP ($\theta_{JA} = 48.7^\circ\text{C/W}$)	189	119	70	mA max
$V_{DD} = 3.3\text{ V}, V_{SS} = 0\text{ V}$				
TSSOP ($\theta_{JA} = 112.6^\circ\text{C/W}$)	94	66	45	mA max
LFCSP ($\theta_{JA} = 48.7^\circ\text{C/W}$)	154	101	63	mA max

ABSOLUTE MAXIMUM RATINGS

$T_A = 25^\circ\text{C}$, unless otherwise noted.

Table 7.

Parameter	Rating
V_{DD} to V_{SS}	18 V
V_{DD} to GND	-0.3 V to +18 V
V_{SS} to GND	+0.3 V to -18 V
Analog Inputs ¹	$V_{SS} - 0.3\text{ V}$ to $V_{DD} + 0.3\text{ V}$ or 30 mA, whichever occurs first
Digital Inputs ¹	GND - 0.3 V to $V_{DD} + 0.3\text{ V}$ or 30 mA, whichever occurs first
Peak Current, S or D	710 mA (pulsed at 1 ms, 10% duty cycle maximum)
Continuous Current, S or D ²	Data + 15%
Operating Temperature Range	
Industrial	-40°C to +125°C
Storage Temperature Range	-65°C to +150°C
Junction Temperature	150°C
16-Lead TSSOP, θ_{JA} Thermal Impedance, 0 Airflow (4-Layer Board)	112.6°C/W
16-Lead LFCSP, θ_{JA} Thermal Impedance, 0 Airflow (4-Layer Board)	48.7°C/W
Reflow Soldering Peak Temperature, Pb-free	260°C

¹ Overvoltages at IN, S, or D are clamped by internal diodes. Current should be limited to the maximum ratings given.

² See Table 5 and Table 6.

Stresses at or above those listed under Absolute Maximum Ratings may cause permanent damage to the product. This is a stress rating only; functional operation of the product at these or any other conditions above those indicated in the operational section of this specification is not implied. Operation beyond the maximum operating conditions for extended periods may affect product reliability.

ESD CAUTION



ESD (electrostatic discharge) sensitive device. Charged devices and circuit boards can discharge without detection. Although this product features patented or proprietary protection circuitry, damage may occur on devices subjected to high energy ESD. Therefore, proper ESD precautions should be taken to avoid performance degradation or loss of functionality.

PIN CONFIGURATIONS AND FUNCTION DESCRIPTIONS

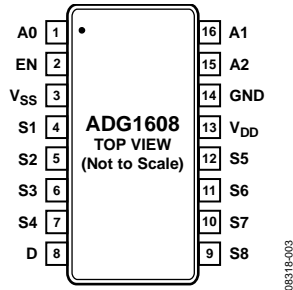
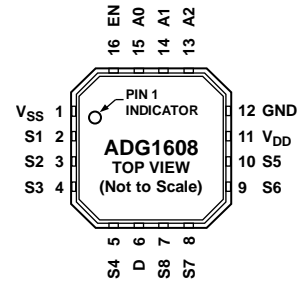

Figure 3. ADG1608 Pin Configuration (TSSOP)



NOTES
 1. THE EXPOSED PAD IS CONNECTED INTERNALLY. FOR INCREASED RELIABILITY OF THE SOLDER JOINTS AND MAXIMUM THERMAL CAPABILITY, IT IS RECOMMENDED THAT THE PAD BE SOLDERED TO THE SUBSTRATE, V_{SS}.

Figure 4. ADG1608 Pin Configuration (LFCSP)

Table 8. ADG1608 Pin Function Descriptions

Pin No.		Mnemonic	Description
TSSOP	LFCSP		
1	15	A0	Logic Control Input.
2	16	EN	Active High Digital Input. When this pin is low, the device is disabled and all switches are off. When this pin is high, Ax logic inputs determine on switches.
3	1	V _{SS}	Most Negative Power Supply Potential. In single-supply applications, this pin can be connected to ground.
4	2	S1	Source Terminal 1. Can be an input or an output.
5	3	S2	Source Terminal 2. Can be an input or an output.
6	4	S3	Source Terminal 3. Can be an input or an output.
7	5	S4	Source Terminal 4. Can be an input or an output.
8	6	D	Drain Terminal. Can be an input or an output.
9	7	S8	Source Terminal 8. Can be an input or an output.
10	8	S7	Source Terminal 7. Can be an input or an output.
11	9	S6	Source Terminal 6. Can be an input or an output.
12	10	S5	Source Terminal 5. Can be an input or an output.
13	11	V _{DD}	Most Positive Power Supply Potential.
14	12	GND	Ground (0 V) Reference.
15	13	A2	Logic Control Input.
16	14	A1	Logic Control Input.
N/A	EP	EP	Exposed Pad. The exposed pad is connected internally. For increased reliability of the solder joints and maximum thermal capability, it is recommended that the pad be soldered to the substrate, V _{SS} .

Table 9. ADG1608 Truth Table

A2	A1	A0	EN	On Switch
X ¹	X ¹	X ¹	0	None
0	0	0	1	1
0	0	1	1	2
0	1	0	1	3
0	1	1	1	4
1	0	0	1	5
1	0	1	1	6
1	1	0	1	7
1	1	1	1	8

¹ X = don't care.

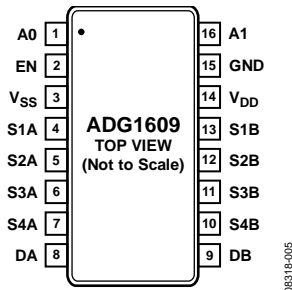
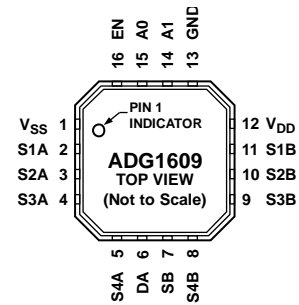

Figure 5. ADG1609 Pin Configuration (TSSOP)



NOTES
 1. THE EXPOSED PAD IS CONNECTED INTERNALLY. FOR INCREASED RELIABILITY OF THE SOLDER JOINTS AND MAXIMUM THERMAL CAPABILITY, IT IS RECOMMENDED THAT THE PAD BE SOLDERED TO THE SUBSTRATE, V_{SS} .

Figure 6. ADG1609 Pin Configuration (LFCSP)

Table 10. ADG1609 Pin Function Descriptions

Pin No.		Mnemonic	Description
TSSOP	LFCSP		
1	15	A0	Logic Control Input.
2	16	EN	Active High Digital Input. When this pin is low, the device is disabled and all switches are off. When this pin is high, Ax logic inputs determine on switches.
3	1	V_{SS}	Most Negative Power Supply Potential. In single-supply applications, this pin can be connected to ground.
4	2	S1A	Source Terminal 1A. Can be an input or an output.
5	3	S2A	Source Terminal 2A. Can be an input or an output.
6	4	S3A	Source Terminal 3A. Can be an input or an output.
7	5	S4A	Source Terminal 4A. Can be an input or an output.
8	6	DA	Drain Terminal A. Can be an input or an output.
9	7	DB	Drain Terminal B. Can be an input or an output.
10	8	S4B	Source Terminal 4B. Can be an input or an output.
11	9	S3B	Source Terminal 3B. Can be an input or an output.
12	10	S2B	Source Terminal 2B. Can be an input or an output.
13	11	S1B	Source Terminal 1B. Can be an input or an output.
14	12	V_{DD}	Most Positive Power Supply Potential.
15	13	GND	Ground (0 V) Reference.
16	14	A1	Logic Control Input.
N/A	EP	EP	Exposed Pad. The exposed pad is connected internally. For increased reliability of the solder joints and maximum thermal capability, it is recommended that the pad be soldered to the substrate, V_{SS} .

Table 11. ADG1609 Truth Table

A1	A0	EN	On Switch Pair
X ¹	X ¹	0	None
0	0	1	1
0	1	1	2
1	0	1	3
1	1	1	4

¹ X = don't care.

TYPICAL PERFORMANCE CHARACTERISTICS

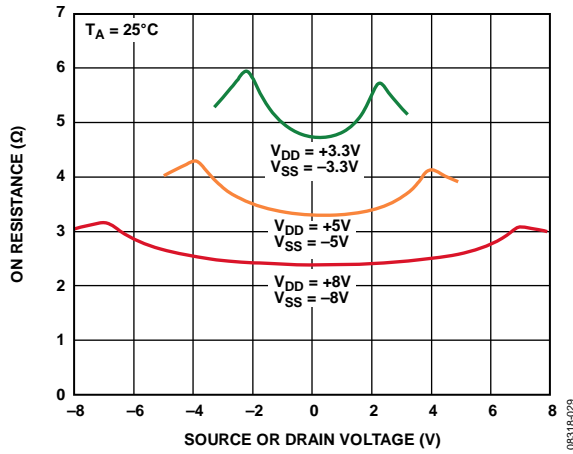

Figure 7. On Resistance vs. V_D (V_S) for Dual Supply

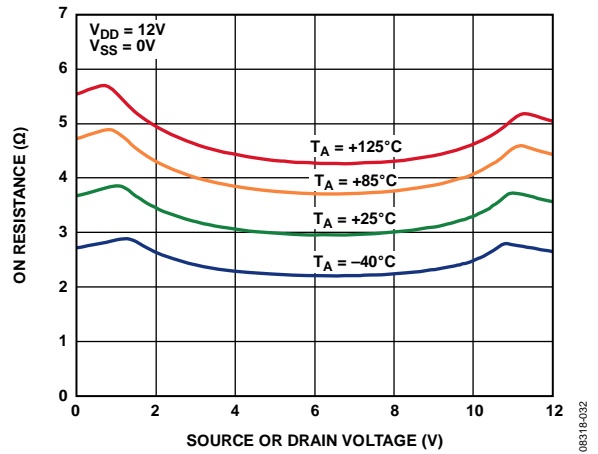

Figure 10. On Resistance vs. V_D (V_S) for Different Temperatures, 12 V Single Supply

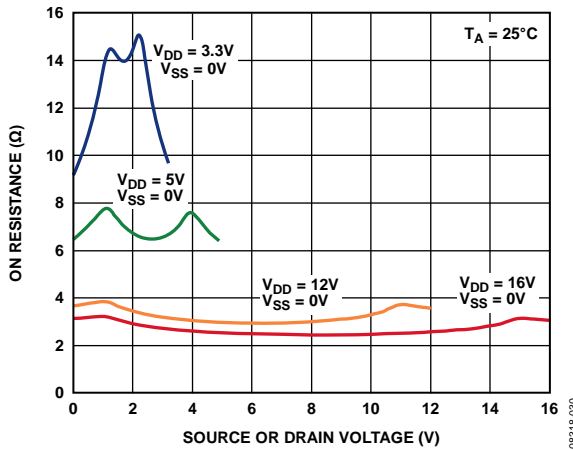

Figure 8. On Resistance vs. V_D (V_S) for Single Supply

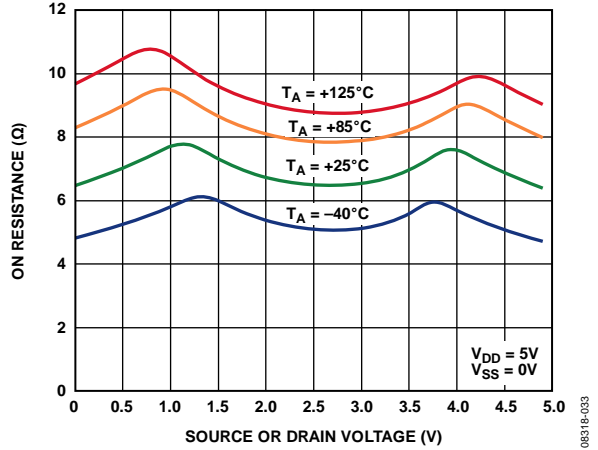

Figure 11. On Resistance vs. V_D (V_S) for Different Temperatures, 5 V Single Supply

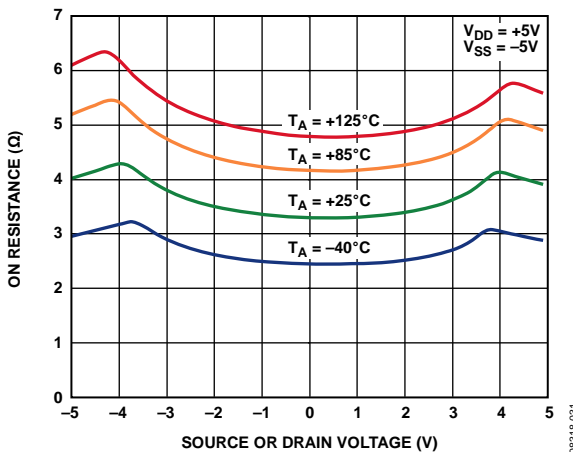

Figure 9. On Resistance vs. V_D (V_S) for Different Temperatures, ± 5 V Dual Supply

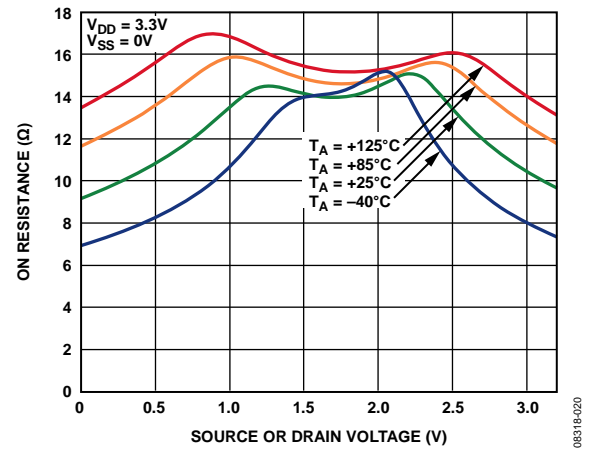

Figure 12. On Resistance vs. V_D (V_S) for Different Temperatures, 3.3 V Single Supply

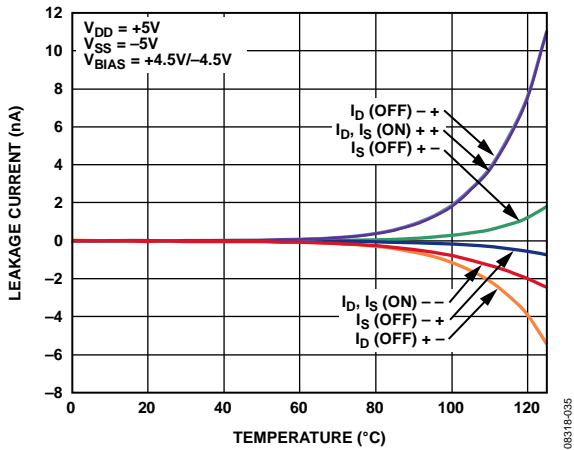

Figure 13. ADG1608 Leakage Currents vs. Temperature, ±5 V Dual Supply

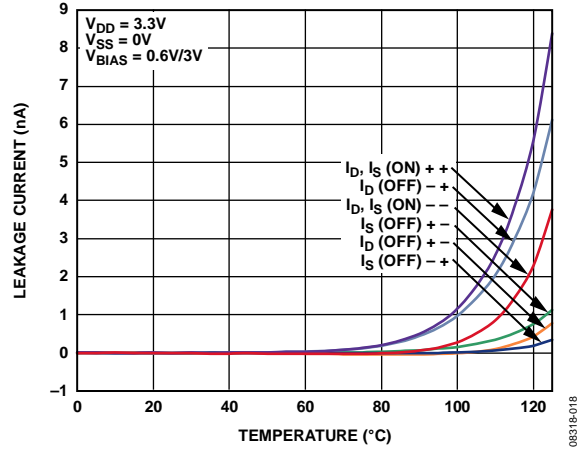

Figure 16. ADG1608 Leakage Currents vs. Temperature, 3.3 V Single Supply

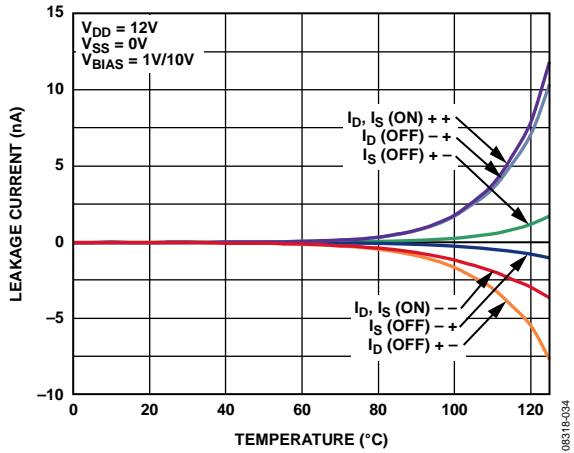

Figure 14. ADG1608 Leakage Currents vs. Temperature, 12 V Single Supply

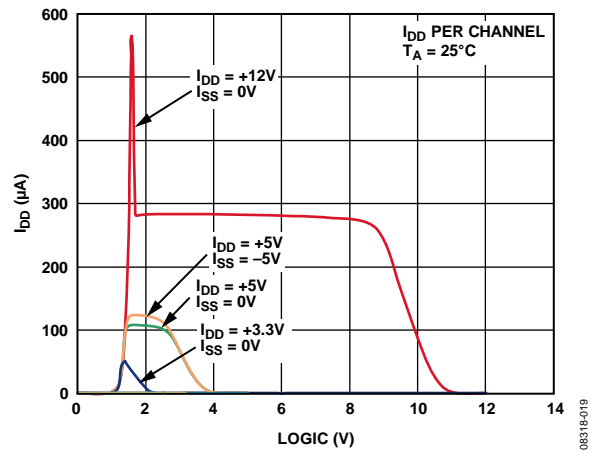

Figure 17. I_{DD} vs. Logic Level

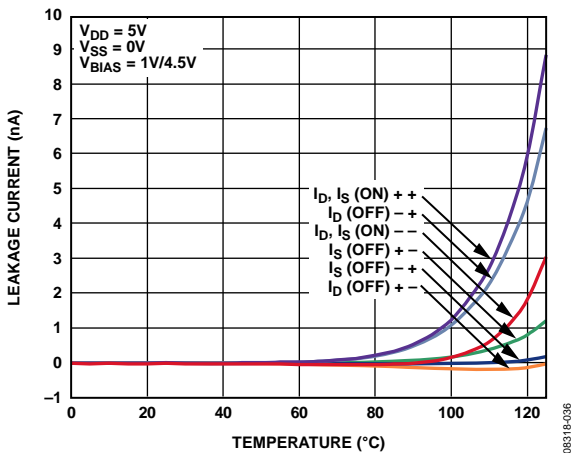

Figure 15. ADG1608 Leakage Currents vs. Temperature, 5 V Single Supply

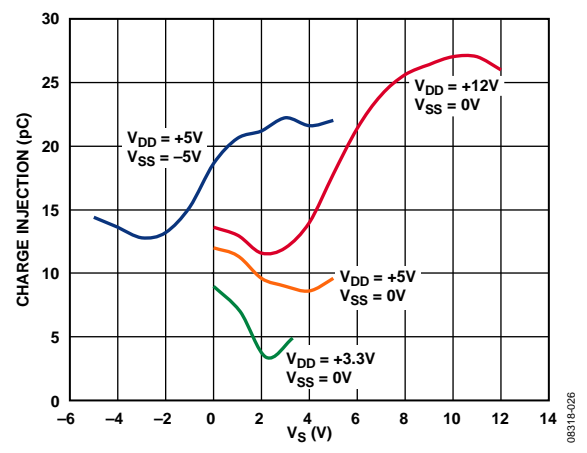

Figure 18. Charge Injection vs. Source Voltage

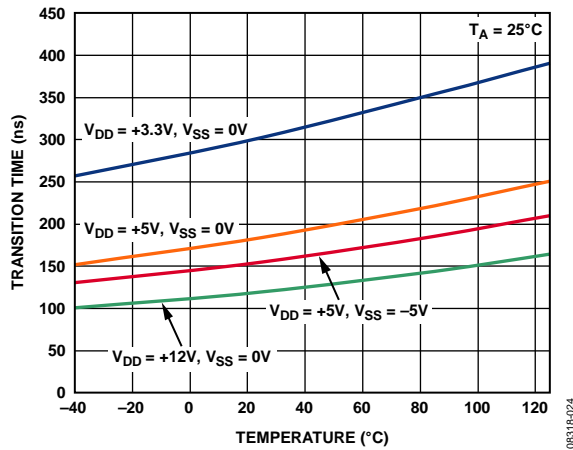

Figure 19. Transition Time vs. Temperature

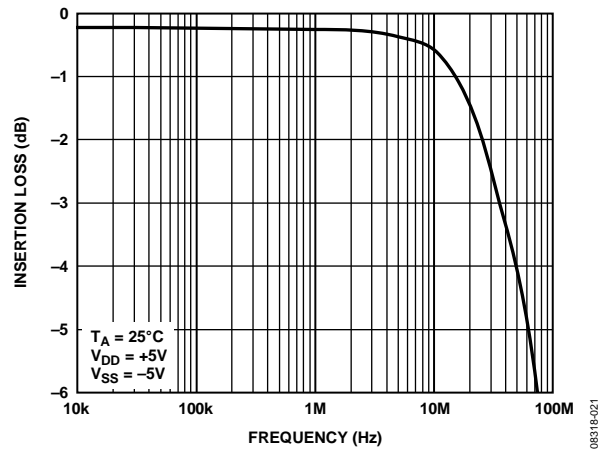

Figure 22. On Response vs. Frequency

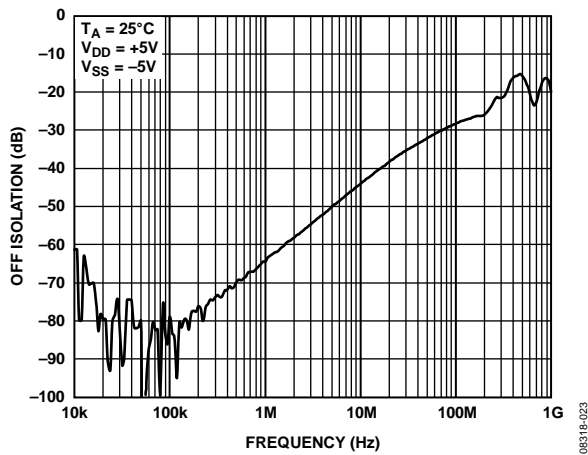

Figure 20. Off Isolation vs. Frequency

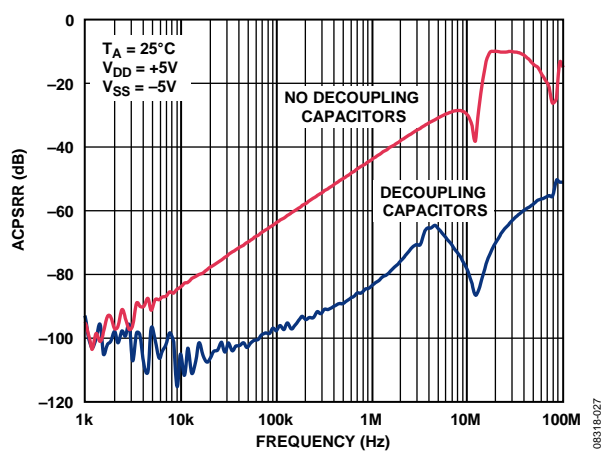

Figure 23. ACPSRR vs. Frequency

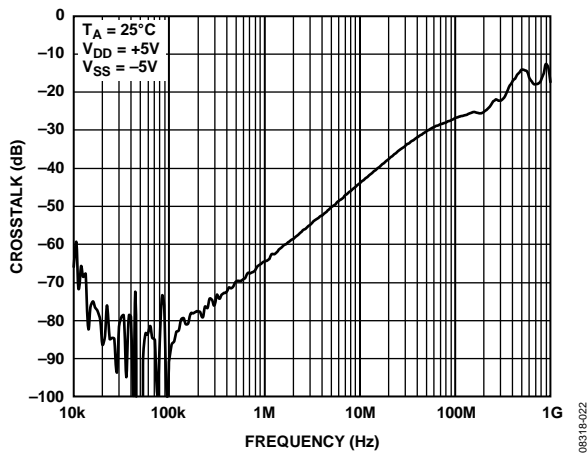

Figure 21. Crosstalk vs. Frequency

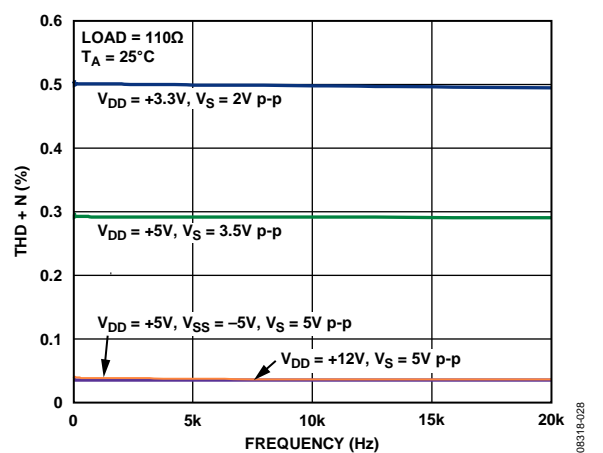

Figure 24. THD + N vs. Frequency

TEST CIRCUITS

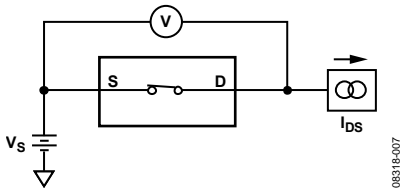

Figure 25. On Resistance

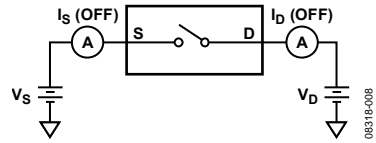

Figure 26. Off Leakage

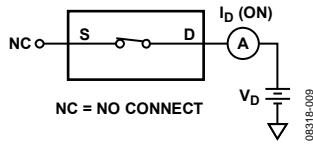
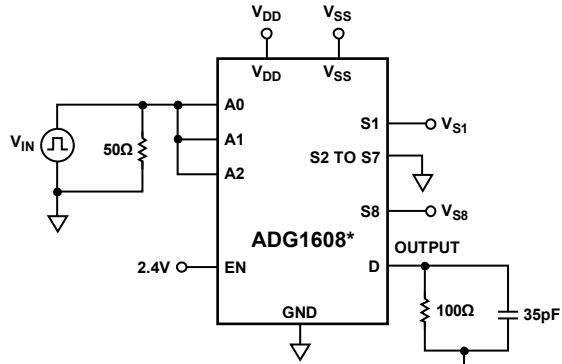
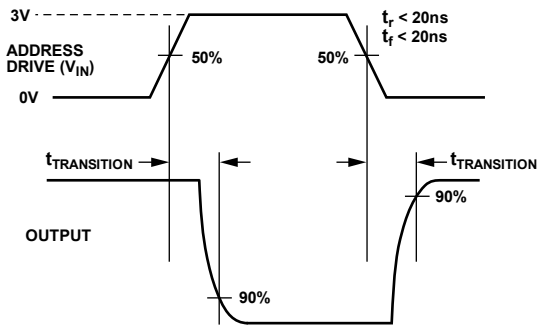
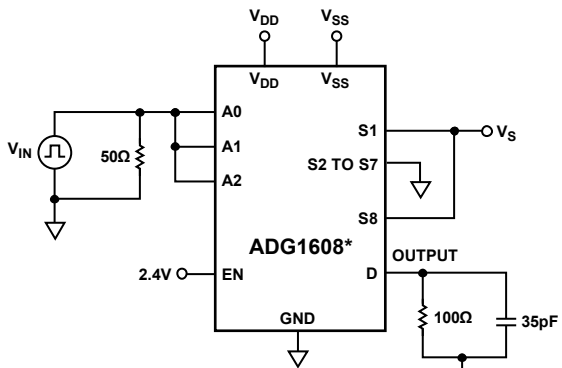
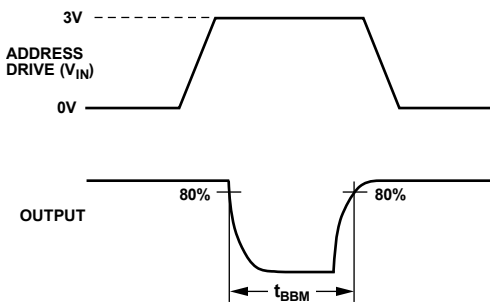

Figure 27. On Leakage



*SIMILAR CONNECTION FOR ADG1609.

Figure 28. Address to Output Switching Times, $t_{TRANSITION}$



*SIMILAR CONNECTION FOR ADG1609.

Figure 29. Break-Before-Make Delay, t_{BBM}

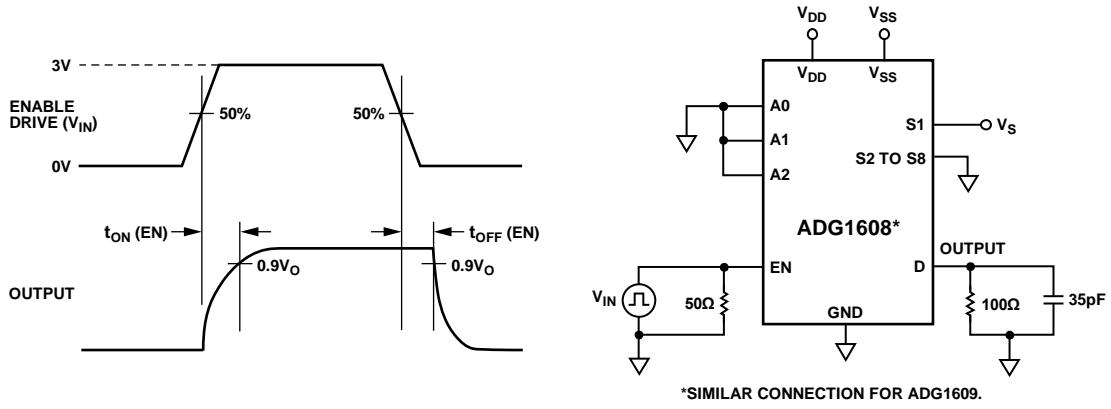

Figure 30. Enable Delay, $t_{ON}(EN)$, $t_{OFF}(EN)$

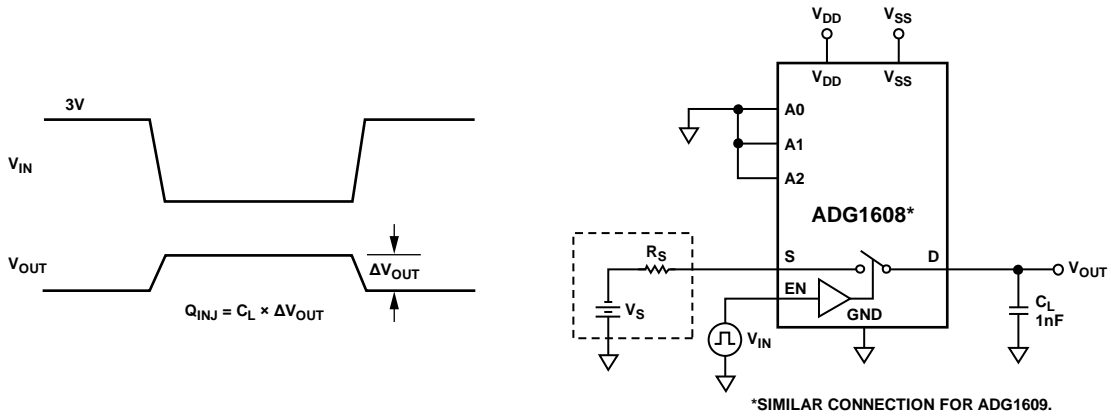

Figure 31. Charge Injection

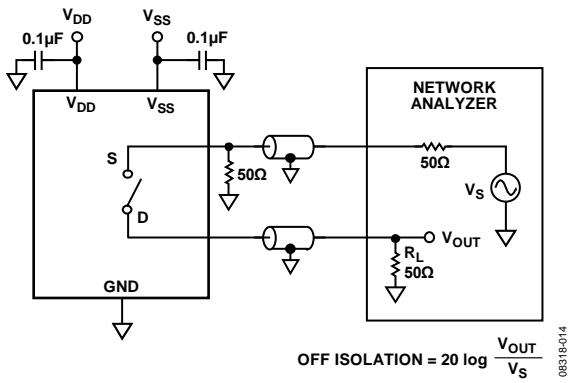

Figure 32. Off Isolation

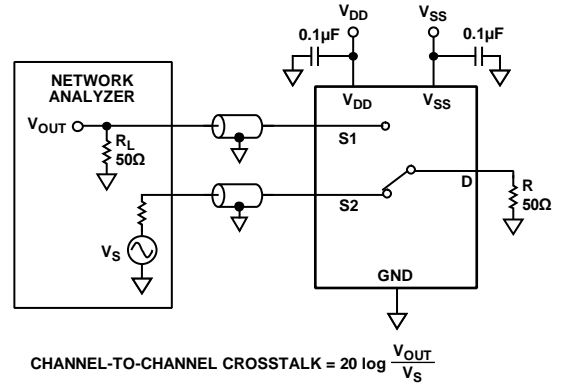

Figure 34. Channel-to-Channel Crosstalk

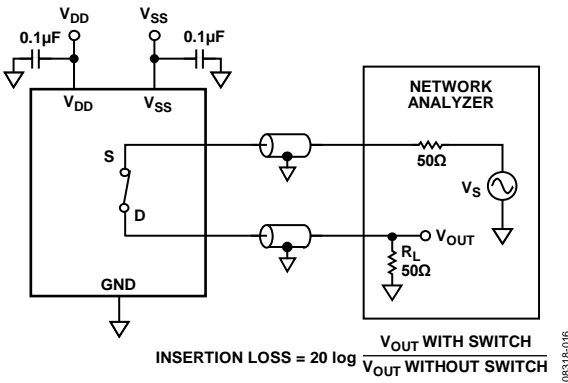

Figure 33. Bandwidth

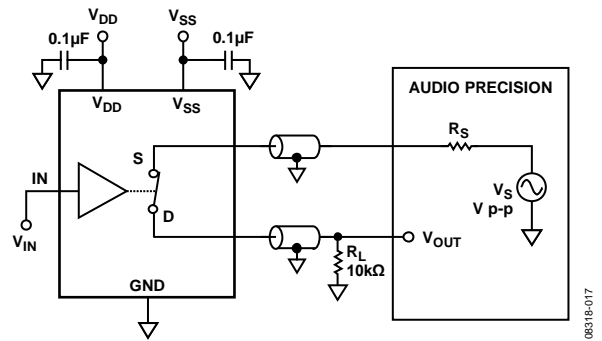

Figure 35. THD + Noise

TERMINOLOGY

I_{DD}

The positive supply current.

I_{SS}

The negative supply current.

V_D (V_S)

The analog voltage on Terminal D and Terminal S.

R_{ON}

The ohmic resistance between Terminal D and Terminal S.

R_{FLAT(ON)}

Flatness that is defined as the difference between the maximum and minimum value of on resistance measured over the specified analog signal range.

I_S (Off)

The source leakage current with the switch off.

I_D (Off)

The drain leakage current with the switch off.

I_D, I_S (On)

The channel leakage current with the switch on.

V_{INL}

The maximum input voltage for Logic 0.

V_{INH}

The minimum input voltage for Logic 1.

I_{INL} (I_{INH})

The input current of the digital input.

C_S (Off)

The off switch source capacitance, which is measured with reference to ground.

C_D (Off)

The off switch drain capacitance, which is measured with reference to ground.

C_D, C_S (On)

The on switch capacitance, which is measured with reference to ground.

C_{IN}

The digital input capacitance.

t_{TRANSITION}

The delay time between the 50% and 90% points of the digital input and switch on condition when switching from one address state to another.

t_{ON} (EN)

The delay between applying the digital control input and the output switching on.

t_{OFF} (EN)

The delay between applying the digital control input and the output switching off.

Charge Injection

A measure of the glitch impulse transferred from the digital input to the analog output during switching.

Off Isolation

A measure of unwanted signal coupling through an off switch.

Crosstalk

A measure of unwanted signal that is coupled through from one channel to another as a result of parasitic capacitance.

Bandwidth

The frequency at which the output is attenuated by 3 dB.

On Response

The frequency response of the on switch.

Insertion Loss

The loss due to the on resistance of the switch.

Total Harmonic Distortion + Noise (THD + N)

The ratio of the harmonic amplitude plus noise of the signal to the fundamental.

AC Power Supply Rejection Ratio (ACPSRR)

The ratio of the amplitude of signal on the output to the amplitude of the modulation. This is a measure of the ability of the part to avoid coupling noise and spurious signals that appear on the supply voltage pin to the output of the switch. The dc voltage on the device is modulated by a sine wave of 0.62 V p-p.

OUTLINE DIMENSIONS

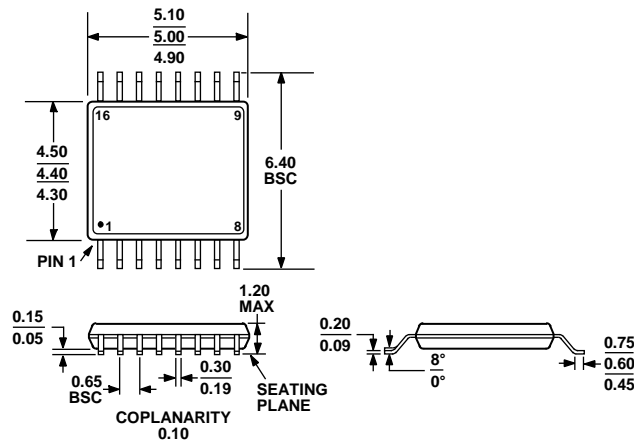

COMPLIANT TO JEDEC STANDARDS MO-153-AB

Figure 36. 16-Lead Thin Shrink Small Outline Package [TSSOP] (RU-16)

Dimensions shown in millimeters

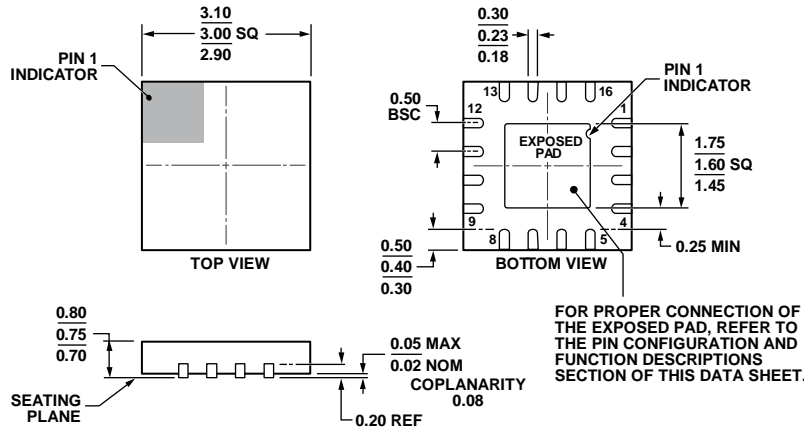

COMPLIANT TO JEDEC STANDARDS MO-220-WEED-6.

Figure 37. 16-Lead Lead Frame Chip Scale Package [LF CSP_WQ] 3 mm x 3 mm Body, Very Very Thin Quad (CP-16-22)

Dimensions shown in millimeters

08-16-2010-E

ORDERING GUIDE

Model ¹	Temperature Range	Package Description	Package Option	Branding
ADG1608BRUZ	-40°C to +125°C	16-Lead Thin Shrink Small Outline Package [TSSOP]	RU-16	
ADG1608BRUZ-REEL7	-40°C to +125°C	16-Lead Thin Shrink Small Outline Package [TSSOP]	RU-16	
ADG1608BCPZ-REEL7	-40°C to +125°C	16-Lead Lead Frame Chip Scale Package [LF CSP_WQ]	CP-16-22	S38
ADG1609BRUZ	-40°C to +125°C	16-Lead Thin Shrink Small Outline Package [TSSOP]	RU-16	
ADG1609BRUZ-REEL7	-40°C to +125°C	16-Lead Thin Shrink Small Outline Package [TSSOP]	RU-16	
ADG1609BCPZ-REEL7	-40°C to +125°C	16-Lead Lead Frame Chip Scale Package [LF CSP_WQ]	CP-16-22	S39

¹ Z = RoHS Compliant Part.

NOTES

NOTES

Looking for pricing, stock, or lifecycle information?

Click below to explore more details on WIN SOURCE:

 [View ADG1608BRUZ-REEL7 on WIN SOURCE](#)

 [Analog Devices Inc. Information](#)

Optimize Your Supply Chain with WIN SOURCE Solutions

-  Global Sourcing Solution
-  Obsolete Management
-  Cost Control Management
-  Shortage Management
-  Alternative Solution
-  Excess Inventory Management