



**THE DATASHEET OF
TMP411AQDGKRQ1**



$\pm 1^{\circ}\text{C}$ Remote and Local Temperature Sensor With N-Factor and Series Resistance Correction

Check for Samples: [TMP411-Q1](#)

FEATURES

- Qualified for Automotive Applications
- AEC-Q100 Qualified With the Following Results
 - Device Temperature Grade 1: -40°C to 125°C Ambient Operating Temperature Range
 - Device HBM ESD Classification Level H2
 - Device CDM ESD Classification Level C4B
- $\pm 1^{\circ}\text{C}$ Remote Diode Sensor
- $\pm 1^{\circ}\text{C}$ Local Temperature Sensor
- Programmable Non-Ideality Factor
- Series Resistance Cancellation
- Alert Function
- Programmable Resolution: 9 to 12 Bits
- Programmable Threshold Limits
- Two-Wire/ SMBus™ Serial Interface
- Minimum and Maximum Temperature Monitors
- Multiple Interface Addresses
- ALERT/THERM2 Pin Configuration
- Diode Fault Detection

APPLICATIONS

- Automotive

DESCRIPTION

The TMP411-Q1 is a remote temperature sensor monitor with a built-in local temperature sensor. The remote temperature-sensor diode-connected transistors are typically low-cost, NPN- or PNP-type transistors or diodes that are an integral part of microcontrollers, microprocessors, or FPGAs.

Remote accuracy is $\pm 1^{\circ}\text{C}$ for multiple IC manufacturers, with no calibration needed. The two-wire serial interface accepts SMBus write byte, read byte, send byte, and receive byte commands to program the alarm thresholds and to read temperature data.

Features that are included in the TMP411-Q1 are: series resistance cancellation, programmable non-ideality factor, programmable resolution, programmable threshold limits, minimum and maximum temperature monitors, wide remote temperature measurement range (up to 150°C), diode fault detection, and temperature alert function.

The TMP411-Q1 is available in an VSSOP-8 package.

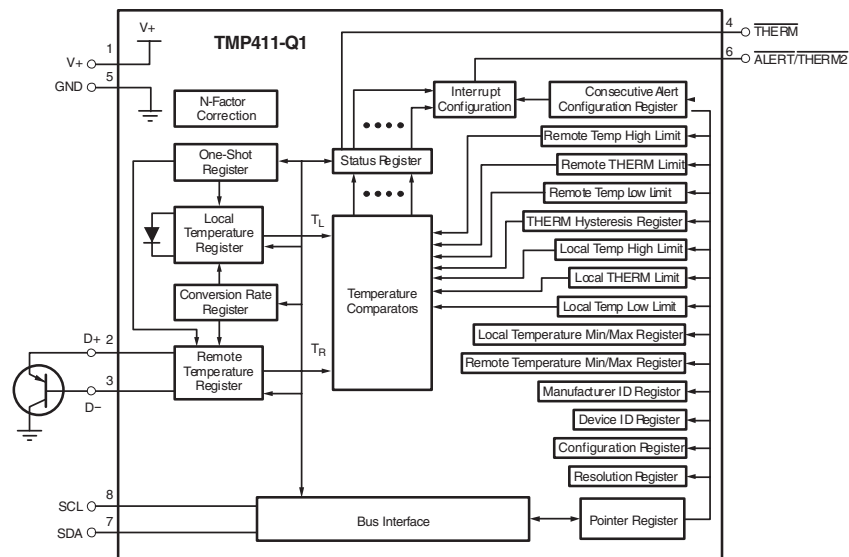

Please be aware that an important notice concerning availability, standard warranty, and use in critical applications of Texas Instruments semiconductor products and disclaimers thereto appears at the end of this data sheet.

SMBus is a trademark of Intel Corp.



This integrated circuit can be damaged by ESD. Texas Instruments recommends that all integrated circuits be handled with appropriate precautions. Failure to observe proper handling and installation procedures can cause damage.

ESD damage can range from subtle performance degradation to complete device failure. Precision integrated circuits may be more susceptible to damage because very small parametric changes could cause the device not to meet its published specifications.

Table 1. ORDERING INFORMATION⁽¹⁾

ORDERABLE PART NUMBER	I ² C ADDRESS	DEFAULT LOCAL HIGH TEMPERATURE LIMIT	DEFAULT REMOTE HIGH TEMPERATURE LIMIT	DEFAULT TEMPERATURE RANGE
TMP411AQDGKRQ1	100 1100	+85°C	+85°C	Standard
TMP411BQDGKRQ1	100 1101	+85°C	+85°C	Standard
TMP411CQDGKRQ1	100 1110	+85°C	+85°C	Standard
TMP411DQDGKRQ1	100 1100	+110°C	+110°C	Standard

(1) For the most current package and ordering information see the Package Option Addendum at the end of this document, or see the TI web site at www.ti.com.

**VSSOP PACKAGE
(TOP VIEW)**

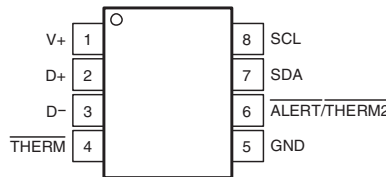

PIN ASSIGNMENTS

PIN	NAME	DESCRIPTION
1	V+	Positive supply (2.7 V to 5.5 V)
2	D+	Positive connection to remote temperature sensor
3	D-	Negative connection to remote temperature sensor
4	THERM	Thermal flag, active-low, open-drain; requires pullup resistor to V+
5	GND	Ground
6	ALERT/THERM2	Alert (reconfigurable as second thermal flag), active-low, open-drain; requires pullup resistor to V+
7	SDA	Serial data line for SMBus, open-drain; requires pullup resistor to V+
8	SCL	Serial clock line for SMBus, open-drain; requires pullup resistor to V+

ABSOLUTE MAXIMUM RATINGS⁽¹⁾

over operating free-air temperature range (unless otherwise noted)

PARAMETER		VALUE	UNIT
Power supply, V_S		7	V
Input voltage	Pins 2, 3, 4 only	-0.5 V to $V_S + 0.5$	V
Input voltage	Pins 6, 7, 8 only	-0.5 V to 7	V
Input current		10	mA
Operating temperature range		-55°C to 127	°C
Storage temperature range		-60°C to 130	°C
Junction temperature (T_J max)		150	°C
ESD rating	Human-body model (HBM) AEC-Q100 Classification Level H2	2	kV
	Charged-device model (CDM) AEC-Q100 Classification Level C4B	750	V

- (1) Stresses beyond those listed under *Absolute Maximum Ratings* may cause permanent damage to the device. These are stress ratings only, and functional operation of the device at these or any other conditions beyond those indicated under *Recommended Operating Conditions* is not implied. Exposure to absolute-maximum-rated conditions for extended periods may degrade device reliability.

ELECTRICAL CHARACTERISTICS

at $T_A = -40^\circ\text{C}$ to $+125^\circ\text{C}$ and $V_S = 2.7\text{V}$ to 5.5V , unless otherwise noted.

PARAMETERS		CONDITIONS	MIN	TYP	MAX	UNITS
Temperature Error						
$T_{E_{LOCAL}}$	Local temperature sensor	$T_A = -40^\circ\text{C}$ to 125°C		± 1.25	± 2.5	°C
$T_{E_{REMOTE}}$	Remote temperature sensor ⁽¹⁾	$T_A = 15^\circ\text{C}$ to 85°C , $V_S = 3.3\text{V}$		± 0.0625	± 1	°C
		$T_A = 15^\circ\text{C}$ to 75°C ,	$T_{DIODE} = -40^\circ\text{C}$ to 150°C , $V_S = 3.3\text{V}$	± 0.0625	± 1	°C
		$T_A = -40^\circ\text{C}$ to 100°C ,		± 1	± 3	°C
		$T_A = -40^\circ\text{C}$ to 125°C ,		± 3	± 5	°C
vs supply	Local/remote	$V_S = 2.7\text{V}$ to 5.5V		± 0.2	± 0.5	°C/V
Temperature Measurement						
Conversion time (per channel)		One-shot mode	105	115	125	ms
Resolution						
Local temperature sensor (programmable)			9		12	Bits
Remote temperature sensor				12		Bits
Remote Sensor Source Currents	High	Series resistance 3 k Ω max.		120		μA
	Medium high			60		μA
	Medium low			12		μA
	Low			6		μA
η	Remote transistor ideality factor	Optimized ideality factor		1.008		
SMBus Interface						
V_{IH}	Logic input high voltage (SCL, SDA)		2.1			V
V_{IL}	Logic Input low voltage (SCL, SDA)			0.8		V
Hysteresis				500		mV
SMBus output low sink current			6			mA
Logic input current			-1	1		μA
SMBus input capacitance (SCL, SDA)				3		pF
SMBus clock frequency					3.4	MHz
SMBus timeout			25	30	35	ms

- (1) Tested with less than 5- Ω effective series resistance and 100-pF differential input capacitance. T_A is the ambient temperature of the TMP411-Q1. T_{DIODE} is the temperature at the remote diode sensor.

ELECTRICAL CHARACTERISTICS (continued)

at $T_A = -40^{\circ}\text{C}$ to $+125^{\circ}\text{C}$ and $V_S = 2.7\text{V}$ to 5.5V , unless otherwise noted.

PARAMETERS		CONDITIONS	MIN	TYP	MAX	UNITS
SCL falling edge to SDA valid time					1	μs
Digital Outputs						
V_{OL}	Output low voltage	$I_{OUT} = 6\text{ mA}$		0.15	0.4	V
I_{OH}	High-level output leakage current ALERT/THERM2 Output low sink current	$V_{OUT} = V_S$ ALERT/THERM2 forced to 0.4 V		0.1	1	μA
	$\overline{\text{THERM}}$ output low sink current	$\overline{\text{THERM}}$ forced to 0.4 V	6			mA

ELECTRICAL CHARACTERISTICS (continued)

 at $T_A = -40^{\circ}\text{C}$ to $+125^{\circ}\text{C}$ and $V_S = 2.7\text{V}$ to 5.5V , unless otherwise noted.

PARAMETERS		CONDITIONS	MIN	TYP	MAX	UNITS
Power Supply						
V_S	Specified voltage range		2.7		5.5	V
I_Q	Quiescent current	0.0625 conversions per second, $V_S = 3.3\text{ V}$		28	30	μA
		Eight conversions per second, $V_S = 3.3\text{ V}$		400	475	μA
		Serial bus inactive, shutdown mode		3	10	μA
		Serial bus active, $f_S = 400\text{ kHz}$, shutdown mode		90		μA
		Serial bus active, $f_S = 3.4\text{ MHz}$, shutdown mode		350		μA
	Undervoltage lockout		2.3	2.4	2.6	V
POR	Power-on-reset threshold			1.6	2.3	V
Temperature Range						
	Specified range		-40		125	$^{\circ}\text{C}$
T_{stg}	Storage range		-60		130	$^{\circ}\text{C}$
	Thermal resistance, VSSOP-8			150		$^{\circ}\text{C}/\text{W}$

TYPICAL CHARACTERISTICS

At $T_A = 25^\circ\text{C}$ and $V_S = 5\text{ V}$, unless otherwise noted.

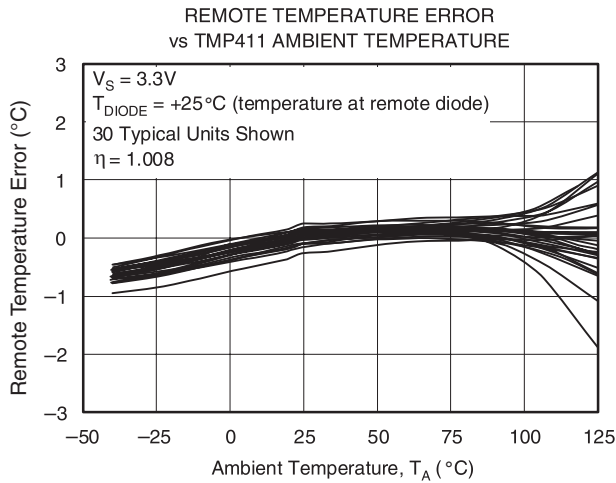

Figure 1.

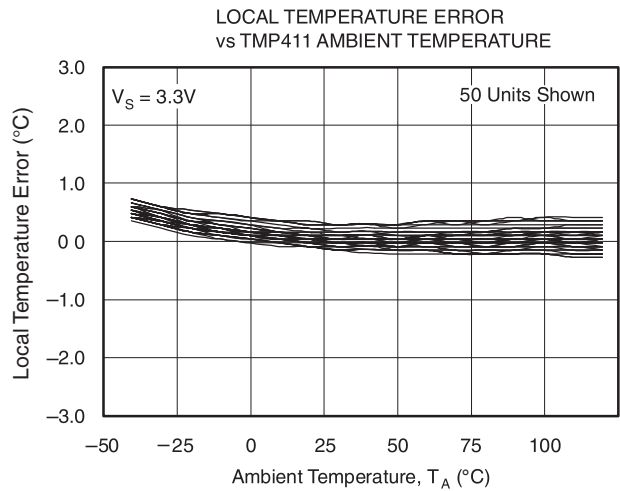

Figure 2.

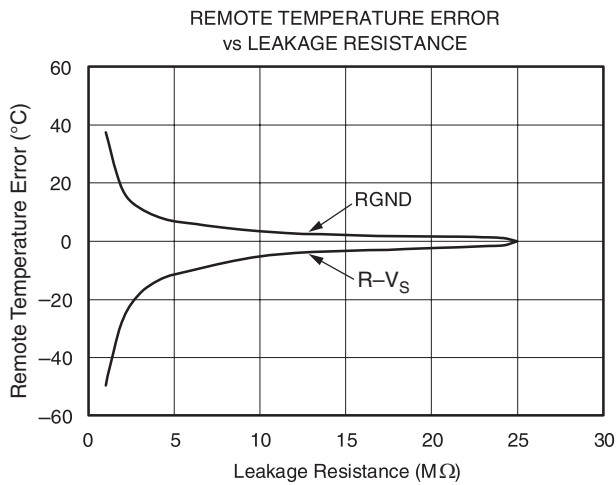

Figure 3.

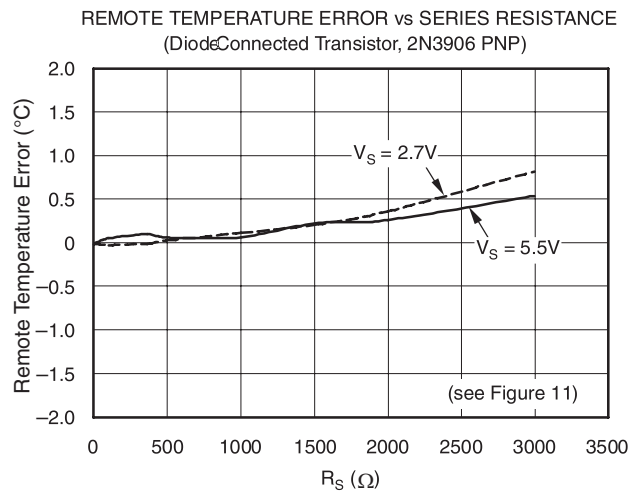

Figure 4.

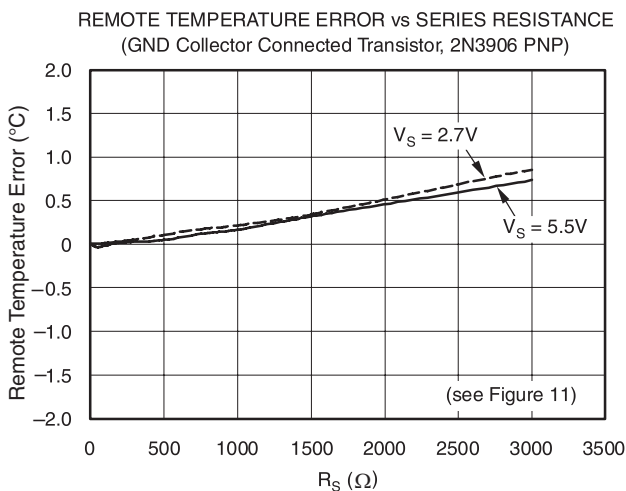

Figure 5.

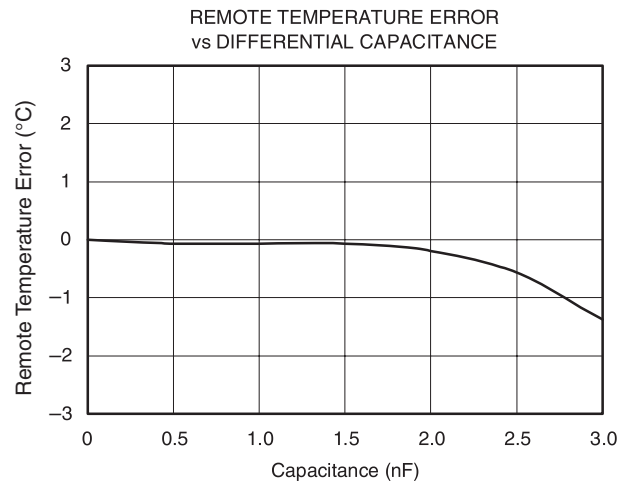

Figure 6.

TYPICAL CHARACTERISTICS (continued)

At $T_A = 25^\circ\text{C}$ and $V_S = 5\text{ V}$, unless otherwise noted.

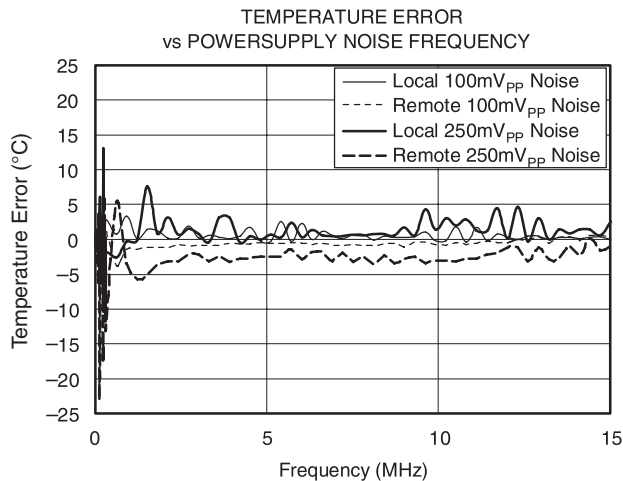

Figure 7.

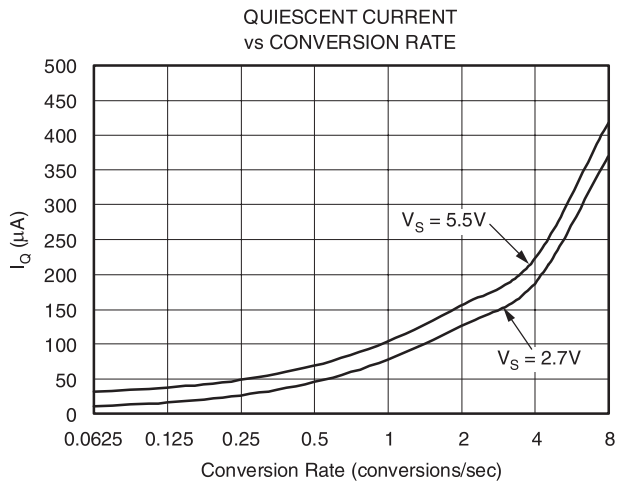

Figure 8.

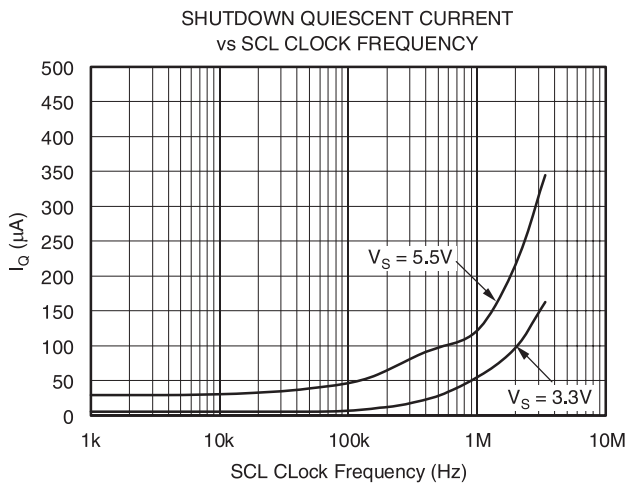

Figure 9.

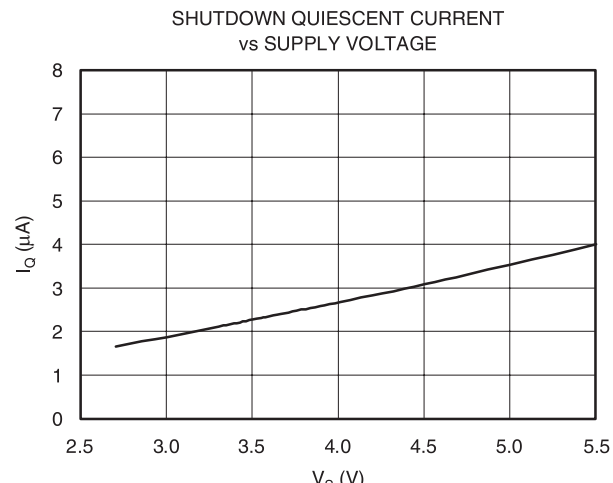

Figure 10.

APPLICATION INFORMATION

The TMP411-Q1 is a dual-channel digital temperature sensor that combines a local die-temperature measurement channel and a remote junction-temperature measurement channel in a single VSSOP-8 package. The TMP411-Q1 is two-wire- and SMBus interface-compatible and is specified over an ambient temperature range of -40°C to 125°C . The TMP411-Q1 contains multiple registers for holding configuration information, temperature measurement results, temperature comparator maximum/minimum limits, and status information.

User-programmed high- and low-temperature limits stored in the TMP411-Q1 can be used to trigger an over- or undertemperature alarm (ALERT) on local and remote temperatures. Additional thermal limits can be programmed into the TMP411-Q1 and used to trigger another flag (THERM) that can be used to initiate a system response to rising temperatures.

The TMP411-Q1 requires only a transistor connected between D+ and D- for proper remote temperature-sensing operation. The SCL and SDA interface pins require pullup resistors as part of the communication bus, whereas ALERT and THERM are open-drain outputs that also need pullup resistors. ALERT and THERM may be shared with other devices if desired for a wired-OR implementation. A 0.1- μF power-supply bypass capacitor is recommended for good local bypassing. Figure 11 shows a typical configuration for the TMP411-Q1.

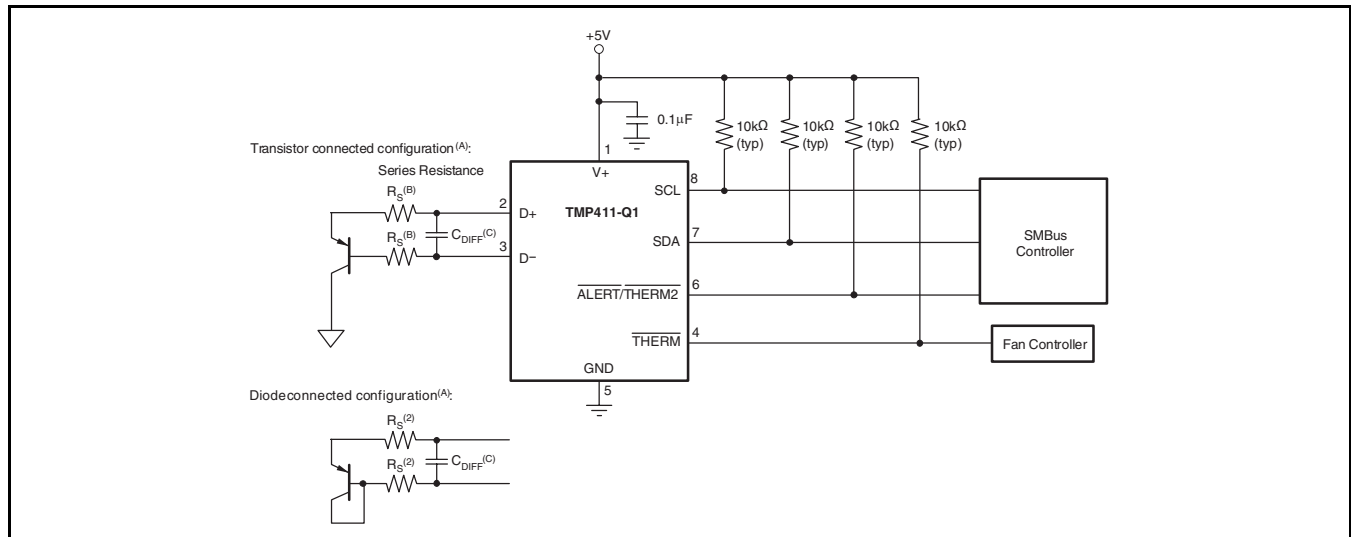

- A. Diode-connected configuration provides better settling time. Transistor-connected configuration provides better series resistance cancellation.
- B. R_S (optional) should be $<1.5\text{ k}\Omega$ in most applications. Selection of R_S depends on specific application; see Filtering section.
- C. C_{DIFF} (optional) should be $<1000\text{ pF}$ in most applications. Selection of C_{DIFF} depends on specific application; see Filtering section and Figure 6, Remote Temperature Error vs Differential Capacitance.

Figure 11. Basic Connections

SERIES RESISTANCE CANCELLATION

Series resistance in an application circuit that typically results from printed circuit board (PCB) trace resistance and remote line length (see [Figure 11](#)) is automatically cancelled by the TMP411-Q1, preventing what would otherwise result in a temperature offset.

A total of up to 3 kΩ of series line resistance is cancelled by the TMP411-Q1, eliminating the need for additional characterization and temperature offset correction.

See the two Remote Temperature Error vs Series Resistance typical characteristics curves ([Figure 4](#) and [Figure 5](#)) for details on the effect of series resistance and power-supply voltage on sensed remote temperature error.

DIFFERENTIAL INPUT CAPACITANCE

The TMP411-Q1 tolerates differential input capacitance of up to 1000 pF with minimal change in temperature error. The effect of capacitance on sensed remote temperature error is illustrated in typical characteristic Remote Temperature Error vs Differential Capacitance ([Figure 6](#)).

TEMPERATURE MEASUREMENT DATA

Temperature measurement data are taken over a default range of 0°C to 127°C for both local and remote locations. Measurements from –55°C to 150°C can be made both locally and remotely by reconfiguring the TMP411-Q1 for the extended temperature range. To change the TMP411-Q1 configuration from the standard to the extended temperature range, switch bit 2 (RANGE) of the Configuration Register from low to high.

Temperature data resulting from conversions within the default measurement range are represented in binary form, as shown in [Table 2](#), Standard Binary column. Note that any temperature below 0°C results in a data value of zero (00h). Likewise, temperatures above 127°C result in a value of 127 (7Fh). The device can be set to measure over an extended temperature range by changing bit 2 of the Configuration Register from low to high. The change in measurement range and data format from standard binary to extended binary occurs at the next temperature conversion. For data captured in the extended temperature range configuration, an offset of 64 (40h) is added to the standard binary value, as shown in [Table 1](#), Extended Binary column. This configuration allows measurement of temperatures below 0°C. Note that binary values corresponding to temperatures as low as –64°C, and as high as 191°C are possible; however, most temperature-sensing diodes only measure with the range of –55°C to 150°C. Additionally, the TMP411-Q1 is rated only for ambient local temperatures ranging from –40°C to 125°C. Parameters in the Absolute Maximum Ratings table must be observed.

**Table 2. Temperature Data Format
(Local and Remote Temperature High Bytes)**

TEMP (°C)	LOCAL/REMOTE TEMPERATURE REGISTER HIGH BYTE VALUE (1°C RESOLUTION)			
	STANDARD BINARY		EXTENDED BINARY	
	BINARY	HEX	BINARY	HEX
–64	0000 0000	00	0000 0000	00
–50	0000 0000	00	0000 1110	0E
–25	0000 0000	00	0010 0111	27
0	0000 0000	00	0100 0000	40
1	0000 0001	01	0100 0001	41
5	0000 0101	05	0100 0101	45
10	0000 1010	0A	0100 1010	4A
25	0001 1001	19	0101 1001	59
50	0011 0010	32	0111 0010	72
75	0100 1011	4B	1000 1011	8b
100	0110 0100	64	1010 0100	A4
125	0111 1101	7D	1011 1101	BD
127	0111 1111	7F	1011 1111	BF
150	0111 1111	7F	1101 0110	D6

**Table 2. Temperature Data Format
(Local and Remote Temperature High Bytes) (continued)**

TEMP (°C)	LOCAL/REMOTE TEMPERATURE REGISTER HIGH BYTE VALUE (1°C RESOLUTION)			
	STANDARD BINARY		EXTENDED BINARY	
	BINARY	HEX	BINARY	HEX
175	0111 1111	7F	1110 1111	EF
191	0111 1111	7F	1111 1111	FF

NOTE

Whenever changing between standard and extended temperature ranges, be aware that the temperatures stored in the temperature limit registers are NOT automatically reformatted to correspond to the new temperature range format. These temperature limit values must be reprogrammed in the appropriate binary or extended binary format.

Both local and remote temperature data use two bytes for data storage. The high byte stores the temperature with 1°C resolution. The second or low byte stores the decimal fraction value of the temperature and allows a higher measurement resolution; see [Table 3](#). The measurement resolution for the remote channel is 0.0625°C, and is not adjustable. The measurement resolution for the local channel is adjustable; it can be set for 0.5°C, 0.25°C, 0.125°C, or 0.0625°C by setting the RES1 and RES0 bits of the Resolution Register; see the Resolution Register section.

**Table 3. Decimal Fraction Temperature Data Format
(Local and Remote Temperature Low Bytes)**

TEMP (°C)	REMOTE TEMPERATURE REGISTER LOW BYTE VALUE		LOCAL TEMPERATURE REGISTER LOW BYTE VALUE							
	0.0625°C RESOLUTION		0.5°C RESOLUTION		0.25°C RESOLUTION		0.125°C RESOLUTION		0.0625°C RESOLUTION	
	STANDARD AND EXTENDED BINARY	HEX	STANDARD AND EXTENDED BINARY	HEX	STANDARD AND EXTENDED BINARY	HEX	STANDARD AND EXTENDED BINARY	HEX	STANDARD AND EXTENDED BINARY	HEX
0.0000	0000 0000	00	0000 0000	00	0000 0000	00	0000 0000	00	0000 0000	00
0.0625	0001 0000	10	0000 0000	00	0000 0000	00	0000 0000	00	0001 0000	10
0.1250	0010 0000	20	0000 0000	00	0000 0000	00	0010 0000	20	0010 0000	20
0.1875	0011 0000	30	0000 0000	00	0000 0000	00	0010 0000	20	0011 0000	30
0.2500	0100 0000	40	0000 0000	00	0100 0000	40	0100 0000	40	0100 0000	40
0.3125	0101 0000	50	0000 0000	00	0100 0000	40	0100 0000	40	0101 0000	50
0.3750	0110 0000	60	0000 0000	00	0100 0000	40	0110 0000	60	0110 0000	60
0.4375	0111 0000	70	0000 0000	00	0100 0000	40	0110 0000	60	0111 0000	70
0.5000	1000 0000	80	1000 0000	80	1000 0000	80	1000 0000	80	1000 0000	80
0.5625	1001 0000	90	1000 0000	80	1000 0000	80	1000 0000	80	1001 0000	90
0.6250	1010 0000	A0	1000 0000	80	1000 0000	80	1010 0000	A0	1010 0000	A0
0.6875	1011 0000	B0	1000 0000	80	1000 0000	80	1010 0000	A0	1011 0000	B0
0.7500	1100 0000	C0	1000 0000	80	1100 0000	C0	1100 0000	C0	1100 0000	C0
0.8125	1101 0000	D0	1000 0000	80	1100 0000	C0	1100 0000	C0	1101 0000	D0
0.8750	1110 0000	E0	1000 0000	80	1100 0000	C0	1110 0000	E0	1110 0000	E0
0.9375	1111 0000	F0	1000 0000	80	1100 0000	C0	1110 0000	E0	1111 0000	F0

REGISTER INFORMATION

The TMP411-Q1 contains multiple registers for holding configuration information, temperature measurement results, temperature comparator maximum and minimum, limits, and status information. These registers are described in [Figure 12](#) and [Table 4](#).

POINTER REGISTER

[Figure 12](#) shows the internal register structure of the TMP411-Q1. The 8-bit Pointer Register is used to address a given data register. The Pointer Register identifies which of the data registers should respond to a read or write command on the two-wire bus. This register is set with every write command. A write command must be issued to set the proper value in the Pointer Register before executing a read command. [Table 4](#) describes the pointer address of the registers available in the TMP411-Q1. Please note read pointer address 0x05, 0x07, 0x19, and 0x20 have different power-on-reset values for A, B, C vs D. The power-on-reset (POR) value of the Pointer Register is 00h (0000 0000b).

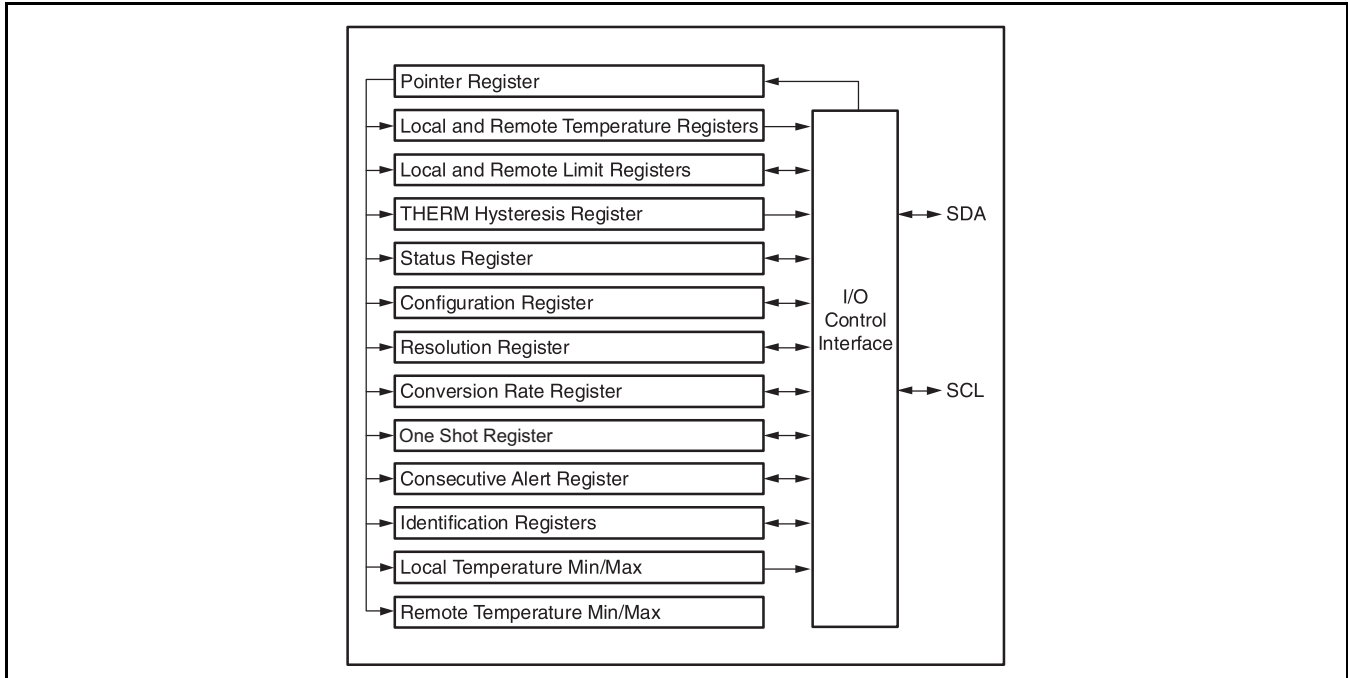

Figure 12. Internal Register Structure

Table 4. Register Map

POINTER ADDRESS (HEX)		POWER-ON RESET (HEX) FOR A, B, AND C	POWER-ON RESET (HEX) FOR D	BIT DESCRIPTIONS								REGISTER DESCRIPTIONS
READ	WRITE			D7	D6	D5	D4	D3	D2	D1	D0	
00	NA ⁽¹⁾	00	00	LT11	LT10	LT9	LT8	LT7	LT6	LT5	LT4	Local Temperature (High Byte)
01	NA	00	00	RT11	RT10	RT9	RT8	RT7	RT6	RT5	RT4	Remote Temperature (High Byte)
02	NA	XX	XX	BUSY	LHIGH	LLOW	RHIGH	RLOW	OPEN	RTHRM	LTHRM	Status Register
03	09	00	00	MASK1	SD	AL/TH	0	0	RANGE	0	0	Configuration Register
04	0A	08	08	0	0	0	0	R3	R2	R1	R0	Conversion Rate Register
05	0B	55	6E	LTH11	LTH10	LTH9	LTH8	LTH7	LTH6	LTH5	LTH4	Local Temperature High Limit (High Byte)
06	0C	00	00	LTL11	LTL10	LTL9	LTL8	LTL7	LTL6	LTL5	LTL4	Local Temperature Low Limit (High Byte)
07	0D	55	6E	RTH11	RTH10	RTH9	RTH8	RTH7	RTH6	RTH5	RTH4	Remote Temperature High Limit (High Byte)
08	0E	00	00	RTL11	RTL10	RTL9	RTL8	RTL7	RTL6	RTL5	RTL4	Remote Temperature Low Limit (High Byte)
NA	0F	XX	XX	X(2)	X	X	X	X	X	X	X	One-Shot Start
10	NA	00	00	RT3	RT2	RT1	RT0	0	0	0	0	Remote Temperature (Low Byte)
13	13	00	00	RTH3	RTH2	RTH1	RTH0	0	0	0	0	Remote Temperature High Limit (Low Byte)
14	14	00	00	RTL3	RTL2	RTL1	RTL0	0	0	0	0	Remote Temperature Low Limit (Low Byte)
15	NA	00	00	LT3	LT2	LT1	LT0	0	0	0	0	Local Temperature (Low Byte)
16	16	00	00	LTH3	LTH2	LTH1	LTH0	0	0	0	0	Local Temperature High Limit (Low Byte)
17	17	00	00	LTL3	LTL2	LTL1	LTL0	0	0	0	0	Local Temperature Low Limit (Low Byte)
18	18	00	00	NC7	NC6	NC5	NC4	NC3	NC2	NC1	NC0	N-factor Correction
19	19	55	6E	RTHL11	RTHL10	RTHL9	RTHL8	RTHL7	RTHL6	RTHL5	RTHL4	Remote THERM Limit
1A	1A	1C	1C	0	0	0	1	1	1	RES1	RES0	Resolution Register

(1) NA = not applicable; register is write- or read-only.

Table 4. Register Map (continued)

POINTER ADDRESS (HEX)		POWER-ON RESET (HEX) FOR A, B, AND C	POWER-ON RESET (HEX) FOR D	BIT DESCRIPTIONS								REGISTER DESCRIPTIONS
READ	WRITE			D7	D6	D5	D4	D3	D2	D1	D0	
20	20	55	6E	LTHL11	LTHL10	LTHL9	LTHL8	LTHL7	LTHL6	LTHL5	LTHL4	Local THERM Limit
21	21	0A	0A	TH11	TH10	TH9	TH8	TH7	TH6	TH5	TH4	THERM Hysteresis
22	22	81	81	TO_EN	0	0	0	C2	C1	C0	0	Consecutive Alert Register
30	30	FF	FF	LMT11	LMT10	LMT9	LMT8	LMT7	LMT6	LMT5	LMT4	Local Temperature Minimum (High Byte)
31	31	F0	F0	LMT3	LMT2	LMT1	LMT0	0	0	0	0	Local Temperature Minimum (Low Byte)
32	32	00	00	LXT11	LXT10	LXT9	LXT8	LXT7	LXT6	LXT5	LXT4	Local Temperature Maximum (High Byte)
33	33	00	00	LXT3	LXT2	LXT1	LXT0	0	0	0	0	Local Temperature Maximum (Low Byte)
34	34	FF	FF	RMT11	RMT10	RMT9	RMT8	RMT7	RMT6	RMT5	RMT4	Remote Temperature Minimum (High Byte)
35	35	F0	F0	RMT3	RMT2	RMT1	RMT0	0	0	0	0	Remote Temperature Minimum (Low Byte)
36	36	00	00	RXT11	RXT10	RXT9	RXT8	RXT7	RXT6	RXT5	RXT4	Remote Temperature Maximum (High Byte)
37	37	00	00	RXT3	RXT2	RXT1	RXT0	0	0	0	0	Remote Temperature Maximum (Low Byte)
NA	FC	XX	XX	X ⁽²⁾	X	X	X	X	X	X	X	Software Reset
FE	NA	55	55	0	1	0	1	0	1	0	1	Manufacturer ID
FF	NA	12	12	0	0	0	1	0	0	1	0	Device ID for TMP411-Q1A
FF	NA	13	13	0	0	0	1	0	0	1	1	Device ID for TMP411-Q1B
FF	NA	10	10	0	0	0	1	0	0	0	0	Device ID for TMP411-Q1C

(2) X = indeterminate state

TEMPERATURE REGISTERS

The TMP411-Q1 has four 8-bit registers that hold temperature measurement results. Both the local channel and the remote channel have a high-byte register that contains the most-significant bits (MSBs) of the temperature analog-to-digital converter (ADC) result and a low-byte register that contains the least-significant bits (LSBs) of the temperature ADC result. The local-channel high-byte address is 00h; the local-channel low-byte address is 15h. The remote-channel high byte is at address 01h; the remote-channel low-byte address is 10h. These registers are read-only and are updated by the ADC each time a temperature measurement is completed.

The TMP411-Q1 contains circuitry to assure that a low-byte register-read command returns data from the same ADC conversion as the immediately preceding high-byte read command. This assurance remains valid only until another register is read. For proper operation, the high byte of a temperature register should be read first. The low-byte register should be read in the next read command. The low byte register may be left unread if the LSBs are not needed. Alternatively, the temperature registers may be read as a 16-bit register by using a single two-byte read command from address 00h for the local-channel result or from address 01h for the remote-channel result. The high byte is output first, followed by the low byte. Both bytes of this read operation are from the same ADC conversion. The power-on-reset value of both temperature registers is 00h.

LIMIT REGISTERS

The TMP411-Q1 has 11 registers for setting comparator limits for both the local and remote measurement channels. These registers have read and write capability. The High and Low Limit Registers for both channels span two registers, as do the temperature registers. The local-temperature high limit is set by writing the high byte to pointer address 0Bh and writing the low byte to pointer address 16h, or by using a single two-byte write command (high byte first) to pointer address 0Bh. The local-temperature high limit is obtained by reading the high byte from pointer address 05h and the low byte from pointer address 16h or by using a two-byte read command from pointer address 05h. The power-on-reset value of the local temperature high limit is 55h/6Eh/00h (85°C in standard temperature mode for TMP411A-Q1 to TMP411C-Q1; 110°C in standard temperature mode for TMP411D-Q1, 21°C in extended temperature range).

Similarly, the local-temperature low limit is set by writing the high byte to pointer address 0Ch and writing the low byte to pointer address 17h, or by using a single two-byte write command to pointer address 0Ch. The local-temperature low limit is read by reading the high byte from pointer address 06h and the low byte from pointer address 17h, or by using a two-byte read from pointer address 06h. The power-on-reset value of the local-temperature low-limit register is 00h/00h (0°C in standard temperature mode; –64°C in extended mode).

The remote-temperature high limit is set by writing the high byte to pointer address 0Dh and writing the low byte to pointer address 13h, or by using a two-byte write command to pointer address 0Dh. The remote-temperature high limit is obtained by reading the high byte from pointer address 07h and the low byte from pointer address 13h, or by using a two-byte read command from pointer address 07h. The power-on-reset value of the Remote Temperature High Limit Register is 55h/6Eh/00h (85°C in standard temperature mode for TMP411A-Q1 to TMP411C-Q1; 110°C in standard temperature mode for TMP411D-Q1; 21°C in extended temperature mode).

The remote-temperature low limit is set by writing the high byte to pointer address 0Eh and writing the low byte to pointer address 14h, or by using a two-byte write to pointer address 0Eh. The remote-temperature low limit is read by reading the high byte from pointer address 08h and the low byte from pointer address 14h, or by using a two-byte read from pointer address 08h. The power-on-reset value of the Remote Temperature Low Limit Register is 00h/00h (0°C in standard temperature mode; –64°C in extended mode).

The TMP411-Q1 also has $\overline{\text{THERM}}$ limit registers for both the local and the remote channels. These registers are eight bits and allow for $\overline{\text{THERM}}$ limits set to 1°C resolution. The local-channel $\overline{\text{THERM}}$ limit is set by writing to pointer address 20h. The remote-channel $\overline{\text{THERM}}$ limit is set by writing to pointer address 19h. The local channel $\overline{\text{THERM}}$ limit is obtained by reading from pointer address 20h; the remote channel $\overline{\text{THERM}}$ limit is read by reading from pointer address 19h. The power-on-reset value of the $\overline{\text{THERM}}$ limit registers is 55h/6Eh/00h (85°C in standard temperature mode for TMP411A-Q1 to TMP411C-Q1; 110°C in standard temperature mode for TMP411D-Q1; 21°C in extended temperature mode). The $\overline{\text{THERM}}$ limit comparators also have hysteresis. The hysteresis of both comparators is set by writing to pointer address 21h. The hysteresis value is obtained by reading from pointer address 21h. The value in the Hysteresis Register is an unsigned number (always positive). The power-on-reset value of this register is 0Ah (10°C).

Whenever changing between standard and extended temperature ranges, be aware that the temperatures stored in the temperature limit registers are not automatically reformatted to correspond to the new temperature range format. These values must be reprogrammed in the appropriate binary or extended binary format.

STATUS REGISTER

The TMP411-Q1 has a Status Register to report the state of the temperature comparators. Table 5 shows the Status Register bits. The Status Register is read-only and is read by reading from pointer address 02h.

The BUSY bit reads as 1 if the ADC is making a conversion. It reads as 0 if the ADC is not converting.

The OPEN bit reads as 1 if the remote transistor was detected as open since the last read of the Status Register. The OPEN status is only detected when the ADC is attempting to convert a remote temperature.

The RTHRM bit reads as 1 if the remote temperature has exceeded the remote $\overline{\text{THERM}}$ limit and remains greater than the remote $\overline{\text{THERM}}$ limit less the value in the shared Hysteresis Register; see Figure 18.

The LTHRM bit reads as 1 if the local temperature has exceeded the local $\overline{\text{THERM}}$ limit and remains greater than the local $\overline{\text{THERM}}$ limit less the value in the shared Hysteresis Register; see Figure 18.

The LHIGH and RHIGH bit values depend on the state of the AL/TH bit in the Configuration Register. If the AL/TH bit is 0, the LHIGH bit reads as 1 if the local high limit was exceeded since the last clearing of the Status Register. The RHIGH bit reads as 1 if the remote high limit was exceeded since the last clearing of the Status Register. If the AL/TH bit is 1, the remote high limit and the local high limit are used to implement a THERM2 function. LHIGH reads as 1 if the local temperature has exceeded the local high limit and remains greater than the local high limit less the value in the Hysteresis Register.

The RHIGH bit reads as 1 if the remote temperature has exceeded the remote high limit and remains greater than the remote high limit less the value in the Hysteresis Register. The LLOW and RLOW bits are not affected by the AL/TH bit.

The LLOW bit reads as 1 if the local low limit was exceeded since the last clearing of the Status Register. The RLOW bit reads as 1 if the remote low limit was exceeded since the last clearing of the Status Register.

The values of the LLOW, RLOW, and OPEN (as well as LHIGH and RHIGH when AL/TH is 0) are latched and read as 1 until the Status Register is read or a device reset occurs. These bits are cleared by reading the Status Register, provided that the condition causing the flag to be set no longer exists. The values of BUSY, LTHRM, and RTHRM (as well as LHIGH and RHIGH when ALERT/THERM2 is 1) are not latched and are not cleared by reading the Status Register. They always indicate the current state, and are updated appropriately at the end of the corresponding ADC conversion. Clearing the Status Register bits does not clear the state of the ALERT pin; an SMBus alert response address command must be used to clear the ALERT pin.

The TMP411-Q1 NORs LHIGH, LLOW, RHIGH, RLOW, and OPEN, so a status change for any of these flags from 0 to 1 automatically causes the ALERT pin to go low (only applies when the ALERT/THERM2 pin is configured for ALERT mode).

Table 5. Status Register Format

STATUS REGISTER (Read = 02h, Write = NA)								
BIT #	D7	D6	D5	D4	D3	D2	D1	D0
BIT NAME	BUSY	LHIGH	LLOW	RHIGH	RLOW	OPEN	RTHRM	LTHRM
POR VALUE	0 ⁽¹⁾	0	0	0	0	0	0	0

(1) The BUSY bit changes to 1 almost immediately (<<100 μs) following power up, as the TMP411-Q1 begins the first temperature conversion. The BUSY bit is high whenever the TMP411-Q1 is converting a temperature reading.

CONFIGURATION REGISTER

The Configuration Register sets the temperature range, controls shutdown mode, and determines how the ALERT/THERM2 pin functions. The Configuration Register is set by writing to pointer address 09h and read by reading from pointer address 03h.

The MASK bit (bit 7) enables or disables the $\overline{\text{ALERT}}$ pin output if AL/TH = 0. If AL/TH = 1, then the MASK bit has no effect. If MASK is set to 0, the $\overline{\text{ALERT}}$ pin goes low when one of the temperature measurement channels exceeds its high or low limits for the chosen number of consecutive conversions. If the MASK bit is set to 1, the TMP411-Q1 retains the $\overline{\text{ALERT}}$ pin status, but the ALERT pin does not go low.

The shutdown (SD) bit (bit 6) enables or disables the temperature measurement circuitry. If SD = 0, the TMP411-Q1 converts continuously at the rate set in the conversion rate register. When SD is set to 1, the TMP411-Q1 immediately stops converting and enters a shutdown mode. When SD is set to 0 again, the TMP411-Q1 resumes continuous conversions. A single conversion can be started when SD = 1 by writing to the One-Shot Register.

The AL/TH bit (bit 5) controls whether the $\overline{\text{ALERT}}$ pin functions in $\overline{\text{ALERT}}$ mode or THERM2 mode. If AL/TH = 0, the $\overline{\text{ALERT}}$ pin operates as an interrupt pin. In this mode, the ALERT pin goes low after the set number of consecutive out-of-limit temperature measurements occurs.

If AL/TH = 1, the $\overline{\text{ALERT/THERM2}}$ pin implements a THERM function (THERM2). In this mode, THERM2 functions similarly to the THERM pin except that the local high limit and remote high limit registers are used for the thresholds. THERM2 goes low when either RHIGH or LHIGH is set.

The temperature range is set by configuring bit 2 of the Configuration Register. Setting this bit low configures the TMP411-Q1 for the standard measurement range (0°C to 127°C), and temperature conversions are stored in the standard binary format. Setting bit 2 high configures the TMP411-Q1 for the extended measurement range (–55°C to 150°C) temperature conversions are stored in the extended binary format (see Table 1).

The remaining bits of the Configuration Register are reserved and must always be set to 0. The power-on-reset value for this register is 00h. [Table 6](#) summarizes the bits of the Configuration Register.

NOTE

The TMP411x-Q1 device family is set to standard temperature range as default. Therefore, the device always needs to be configured to extended temperature range after power-up if this feature is used.

Table 6. Configuration Register Bit Descriptions

CONFIGURATION REGISTER (Read = 03h, Write = 09h, POR = 00h)			
BIT	NAME	FUNCTION	POWER-ON RESET VALUE
7	MASK	0 = $\overline{\text{ALERT}}$ enabled; 1 = $\overline{\text{ALERT}}$ masked	0
6	SD	0 = Run; 1 = Shut down	0
5	AL/TH	0 = $\overline{\text{ALERT}}$ mode; 1 = THERM mode	0
4, 3	Reserved	—	0
2	Temperature range	0 = 0°C to 127°C; 1 = –55°C to 150°C	0
1, 0	Reserved	—	0

RESOLUTION REGISTER

The RES1 and RES0 bits (resolution bits 1 and 0) of the Resolution Register set the resolution of the local temperature measurement channel. Remote temperature measurement channel resolution is not affected. Changing the local channel resolution also affects the conversion time and rate of the TMP411-Q1. The Resolution Register is set by writing to pointer address 1Ah and is read by reading from pointer address 1Ah. Table 7 shows the resolution bits for the Resolution Register.

Table 7. Resolution Register: Local Channel Programmable Resolution

RESOLUTION REGISTER (Read = 1Ah, Write = 1Ah, POR = 1Ch)			
RES1	RES0	RESOLUTION	CONVERSION TIME (Typical)
0	0	9 bits (0.5°C)	12.5 ms
0	1	10 bits (0.25°C)	25 ms
1	0	11 bits (0.125°C)	50 ms
1	1	12 bits (0.0625°C)	100 ms

Bits 2 through 4 of the Resolution Register must always be set to 1. Bits 5 through 7 of the Resolution Register must always be set to 0. The power-on-reset value of this register is 1Ch.

CONVERSION RATE REGISTER

The Conversion Rate Register controls the rate at which temperature conversions are performed. This register adjusts the idle time between conversions but not the conversion timing itself, thereby allowing the TMP411-Q1 power dissipation to be balanced with the temperature register update rate. Table 8 shows the conversion rate options and corresponding current consumption.

ONE-SHOT CONVERSION

When the TMP411-Q1 is in shutdown mode (SD = 1 in the Configuration Register), a single conversion on both channels is started by writing any value to the One-Shot Start Register, pointer address 0Fh. This write operation starts one conversion; the TMP411-Q1 returns to shutdown mode when that conversion completes. The value of the data sent in the write command is irrelevant and is not stored by the TMP411-Q1. When the TMP411-Q1 is in shutdown mode, an initial 200 μs is required before a one-shot command can be given. (NOTE: When a shutdown command is issued, the TMP411-Q1 completes the current conversion before shutting down.) This wait time only applies to the 200 μs immediately following shutdown. One-shot commands can be issued without delay thereafter.

Table 8. Conversion Rate Register

CONVERSION RATE REGISTER (Read = 04h, Write = 0Ah, POR = 08h)										
R7	R6	R5	R4	R3	R2	R1	R0	CONVERSION/SEC	AVERAGE IQ (TYP) (μA)	
									V _S = 2.7V	V _S = 5.5V
0	0	0	0	0	0	0	0	0.0625	11	32
0	0	0	0	0	0	0	1	0.125	17	38
0	0	0	0	0	0	1	0	0.25	28	49
0	0	0	0	0	0	1	1	0.5	47	69
0	0	0	0	0	1	0	0	1	80	103
0	0	0	0	0	1	0	1	2	128	155
0	0	0	0	0	1	1	0	4	190	220
07h to 0Fh								8	373	413

N-FACTOR CORRECTION REGISTER

The TMP411-Q1 allows for a different n -factor value to be used for converting remote-channel measurements to temperature. The remote channel uses sequential current excitation to extract a differential V_{BE} voltage measurement to determine the temperature of the remote transistor. Equation 1 relates this voltage and temperature.

$$V_{BE2} - V_{BE1} = \frac{nkT}{q} \ln\left(\frac{I_2}{I_1}\right) \quad (1)$$

The value n in Equation 1 is a characteristic of the particular transistor used for the remote channel. The default value for the TMP411-Q1 is $n = 1.008$. The value in the N-Factor Correction Register may be used to adjust the effective n -factor according to Equation 2 and Equation 3.

$$n_{eff} = \frac{1.008 \cdot 300}{(300 - N_{ADJUST})} \quad (2)$$

$$N_{ADJUST} = 300 - \left(\frac{300 \cdot 1.008}{n_{eff}} \right) \quad (3)$$

The n -correction value must be stored in two's-complement format, yielding an effective data range from -128 to 127 , as shown in Table 9. The n -correction value may be written to and read from pointer address 18h. The register power-on-reset value is 00h, thus having no effect unless written to.

Table 9. N-Factor Range

BINARY	N _{ADJUST}		N
	HEX	DECIMAL	
0111 1111	7F	127	1.747977
0000 1010	0A	10	1.042759
0000 1000	08	8	1.035616
0000 0110	06	6	1.028571
0000 0100	04	4	1.021622
0000 0010	02	2	1.014765
0000 0001	01	1	1.011371
0000 0000	00	0	1.008
1111 1111	FF	-1	1.004651
1111 1110	FE	-2	1.001325
1111 1100	FC	-4	0.994737
1111 1010	FA	-6	0.988235
1111 1000	F8	-8	0.981818
1111 0110	F6	-10	0.975484
1000 0000	80	-128	0.706542

MINIMUM AND MAXIMUM REGISTERS

The TMP411-Q1 stores the minimum and maximum temperature measured since power on, chip reset, or minimum and maximum register reset for both the local and remote channels. The Local Temperature Minimum Register may be read by reading the high byte from pointer address 30h and the low byte from pointer address 31h. The Local Temperature Minimum Register may also be read by using a two-byte read command from pointer address 30h. The Local Temperature Minimum Register is reset at power on, by executing the chip-reset command, or by writing any value to any of pointer addresses 30h through 37h. The reset value for these registers is FFh/F0h.

The Local Temperature Maximum Register may be read by reading the high byte from pointer address 32h and the low byte from pointer address 33h. The Local Temperature Maximum Register may also be read by using a two-byte read command from pointer address 32h. The Local Temperature Maximum Register is reset at power on by executing the chip reset command, or by writing any value to any of pointer addresses 30h through 37h. The reset value for these registers is 00h/00h.

The Remote Temperature Minimum Register may be read by reading the high byte from pointer address 34h and the low byte from pointer address 35h. The Remote Temperature Minimum Register may also be read by using a two-byte read command from pointer address 34h. The Remote Temperature Minimum Register is reset at power on by executing the chip reset command, or by writing any value to any of pointer addresses 30h through 37h. The reset value for these registers is FFh/F0h.

The Remote Temperature Maximum Register may be read by reading the high byte from pointer address 36h and the low byte from pointer address 37h. The Remote Temperature Maximum Register may also be read by using a two-byte read command from pointer address 36h. The Remote Temperature Maximum Register is reset at power on by executing the chip reset command, or by writing any value to any of pointer addresses 30h through 37h. The reset value for these registers is 00h/00h.

SOFTWARE RESET

The TMP411-Q1 may be reset by writing any value to Pointer Register FCh. This restores the power-on-reset state to all of the TMP411-Q1 registers as well as aborting any conversion in process and clearing the ALERT and THERM pins.

The TMP411-Q1 also supports reset via the two-wire general call address (00000000). The TMP411-Q1 acknowledges the general call address and responds to the second byte. If the second byte is 0000110, the TMP411-Q1 executes a software reset. The TMP411-Q1 takes no action in response to other values in the second byte.

CONSECUTIVE ALERT REGISTER

The value in the Consecutive Alert Register (address 22h) determines how many consecutive out-of-limit measurements must occur on a measurement channel before the ALERT signal is activated. The value in this register does not affect bits in the Status Register. Values of one, two, three, or four consecutive conversions can be selected; one conversion is the default. This function allows additional filtering for the ALERT pin. The consecutive alert bits are shown in [Table 10](#).

Table 10. Consecutive Alert Register

CONSECUTIVE ALERT REGISTER (READ = 22h, WRITE = 22h, POR = 01h)			NUMBER OF CONSECUTIVE OUT-OF-LIMIT MEASUREMENTS
C2	C1	C0	
0	0	0	1
0	0	1	2
0	1	1	3
1	1	1	4

NOTE

Bit 7 of the Consecutive Alert Register controls the enable/disable of the timeout function. See the Timeout Function section for a description of this feature.

THERM HYSTERESIS REGISTER

The THERM Hysteresis Register, shown in [Table 12](#), stores the hysteresis value used for the THERM pin alarm function. This register must be programmed with a value that is less than the Local Temperature High Limit Register value, Remote Temperature High Limit Register value, Local THERM Limit Register value, or Remote THERM Limit Register value; otherwise, the respective temperature comparator does not trip on the measured temperature falling edges. Allowable hysteresis values are shown in [Table 11](#). The default hysteresis value is 10°C, whether the device is operating in the standard or extended mode setting.

Table 11. Allowable THERM Hysteresis Val

TEMPERATURE (°C)	THERM HYSTERESIS VALUE	
	TH[11:4] (STANDARD BINARY)	(HEX)
0	0000 0000	00
1	0000 0001	01
5	0000 0101	05
10	0000 1010	0A
25	0001 1001	19
50	0011 0010	32
75	0100 1011	4B
100	0110 0100	64
125	0111 1101	7D
127	0111 1111	7F
150	1001 0110	96
175	1010 1111	AF
200	1100 1000	C8
225	1110 0001	E1

Table 11. Allowable THERM Hysteresis Val (continued)

TEMPERATURE (°C)	THERM HYSTERESIS VALUE	
	TH[11:4] (STANDARD BINARY)	(HEX)
255	1111 1111	FF

BUS OVERVIEW

The TMP411-Q1 is SMBus interface-compatible. In SMBus protocol, the device that initiates the transfer is called a master, and the devices controlled by the master are slaves. The bus must be controlled by a master device that generates the serial clock (SCL), controls the bus access, and generates the START and STOP conditions.

To address a specific device, a START condition is initiated. START is indicated by pulling the data line (SDA) from a high to low logic level while SCL is high. All slaves on the bus shift in the slave address byte, with the last bit indicating whether a read or write operation is intended. During the ninth clock pulse, the slave being addressed responds to the master by generating an Acknowledge and pulling SDA low.

Data transfer is then initiated and sent over eight clock pulses followed by an Acknowledge bit. During data transfer, SDA must remain stable while SCL is high, because any change in SDA while SCL is high is interpreted as a control signal.

Once all data has been transferred, the master generates a STOP condition. STOP is indicated by pulling SDA from low to high while SCL is high.

SERIAL INTERFACE

The TMP411-Q1 operates only as a slave device on either the two-wire bus or the SMBus. Connections to either bus are made via the open-drain I/O lines, SDA and SCL. The SDA and SCL pins feature integrated spike suppression filters and Schmitt triggers to minimize the effects of input spikes and bus noise. The TMP411-Q1 supports the transmission protocol for fast (1-kHz to 400-kHz) and high-speed (1-kHz to 3.4-MHz) modes. All data bytes are transmitted MSB-first.

SERIAL BUS ADDRESS

To communicate with the TMP411-Q1, the master must first address slave devices via a slave address byte. The slave address byte consists of seven address bits, and a direction bit indicating the intent of executing a read or write operation. The address of the TMP411A-Q1 and TMP411D-Q1 is 4Ch (1001 100b).

READ/WRITE OPERATIONS

Accessing a particular register on the TMP411-Q1 is accomplished by writing the appropriate value to the Pointer Register. The value for the Pointer Register is the first byte transferred after the slave address byte with the R/W bit low. Every write operation to the TMP411-Q1 requires a value for the Pointer Register (see [Figure 14](#)).

When reading from the TMP411-Q1, the last value stored in the Pointer Register by a write operation is used to determine which register is read by a read operation. To change the register pointer for a read operation, a new value must be written to the Pointer Register. This transaction is accomplished by issuing a slave address byte with the R/W bit low, followed by the Pointer Register byte. No additional data are required. The master can then generate a START condition and send the slave address byte with the R/W bit high to initiate the read command. See [Figure 15](#) for details of this sequence. If repeated reads from the same register are desired, it is not necessary to continually send the Pointer Register bytes, because the TMP411-Q1 retains the Pointer Register value until it is changed by the next write operation. Note that register bytes are sent MSB-first, followed by the LSB.

Table 12. THERM Hysteresis Register Format

THERM HYSTERESIS REGISTER (Read = 21h, Write = 21h, POR = 0Ah)								
BIT #	D7D7	D6D6	D5D5	D4D4	D3D3	D2D2	D1D1	D0D0
BIT NAME	TH11	TH10	TH9	TH8	TH7	TH6	TH5	TH4
POR VALUE	0	0	0	0	1	0	1	0

TIMING DIAGRAMS

The TMP411-Q1 is two-wire and SMBus-compatible. Figure 13 to Figure 17 describe the various operations on the TMP411-Q1. Bus definitions are given as follows. Parameters for Figure 13 are defined in Table 13.

Bus Idle: Both SDA and SCL lines remain high.

Start Data Transfer: A change in the state of the SDA line, from high to low, while the SCL line is high, defines a START condition. Each data transfer is initiated with a START condition.

Stop Data Transfer: A change in the state of the SDA line from low to high while the SCL line is high defines a STOP condition. Each data transfer terminates with a STOP or a repeated START condition.

Data Transfer: The number of data bytes transferred between a START and a STOP condition is not limited and is determined by the master device. The receiver acknowledges the transfer of data.

Acknowledge: Each receiving device, when addressed, is obliged to generate an Acknowledge bit. A device that acknowledges must pull down the SDA line during the Acknowledge clock pulse in such a way that the SDA line is stable low during the high period of the Acknowledge clock pulse. Setup and hold times must be taken into account. On a master receive, data transfer termination can be signaled by the master generating a Not-Acknowledge on the last byte that has been transmitted by the slave.

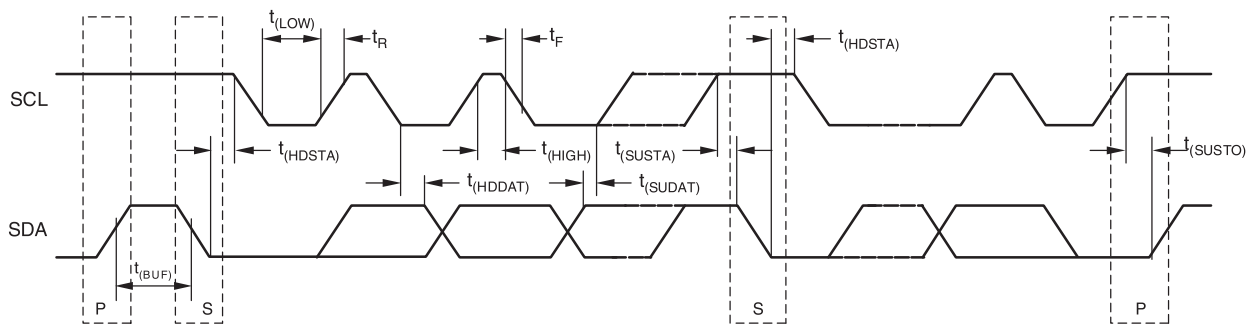
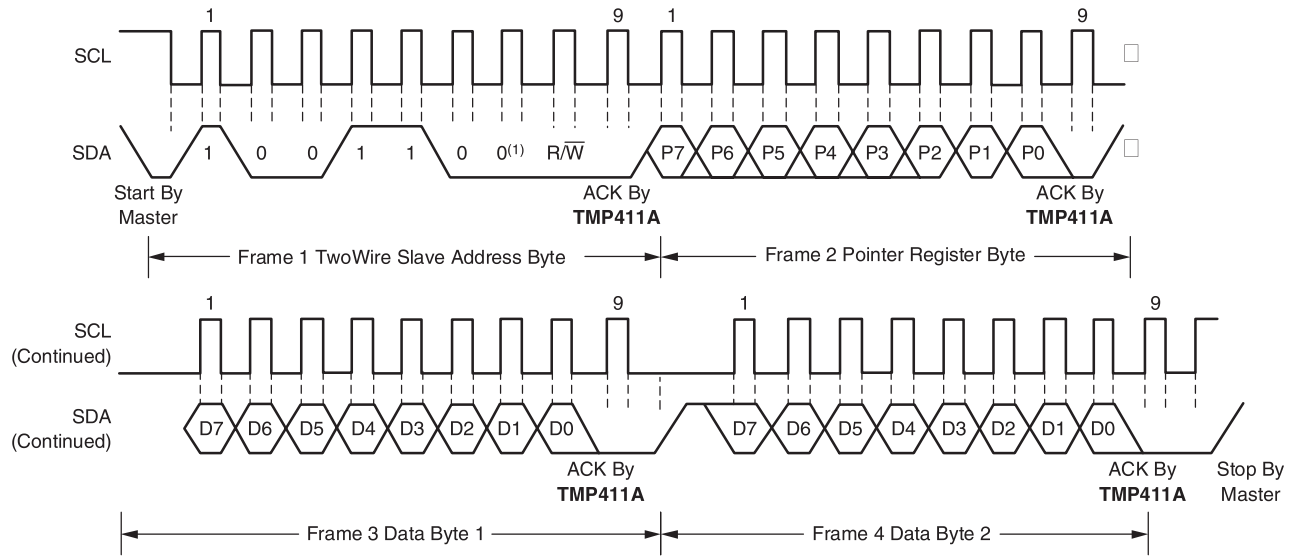

Figure 13. Two-Wire Timing Diagram

Table 13. Timing Diagram Definitions for Figure 13

PARAMETER	FAST MODE		HIGH-SPEED MODE		UNITS			
	MIN	MAX	MIN	MAX				
$f_{(SCL)}$	SCL operating frequency		0.001	0.4	0.001	3.4	MHz	
$t_{(BUF)}$	Bus free time between STOP and START conditions		600		160		ns	
$t_{(HDSTA)}$	Hold time after repeated START condition. After this period, the first clock is generated.		100		100		ns	
$t_{(SUSTA)}$	Repeated START condition setup time		100		100		ns	
$t_{(SUSTO)}$	STOP condition setup time		100		100		ns	
$t_{(HDDAT)}$	Data hold time		0 ⁽¹⁾		0 ⁽²⁾		ns	
$t_{(SUDAT)}$	Data setup time		100		10		ns	
$t_{(LOW)}$	SCL clock LOW period		1300		160		ns	
$t_{(HIGH)}$	SCL clock HIGH period		600		60		ns	
t_f	Clock and data fall time				300		160	ns
t_r	Clock and data rise time				300		160	ns
t_r	for SCLK ≤ 100 kHz				1000		ns	

- (1) For cases with fall time of SCL less than 20 ns and/or the rise time or fall time of SDA less than 20 ns, the hold time should be greater than 20 ns.
- (2) For cases with fall time of SCL less than 10 ns and/or the rise or fall time of SDA less than 10 ns, the hold time should be greater than 10 ns.



A. Slave address 1001 100 (TMP411A and TMP411D) shown. Slave address changes for TMP411B and TMP411C. See Ordering Information table for more details.

Figure 14. Two-Wire Timing Diagram for Write Word Format

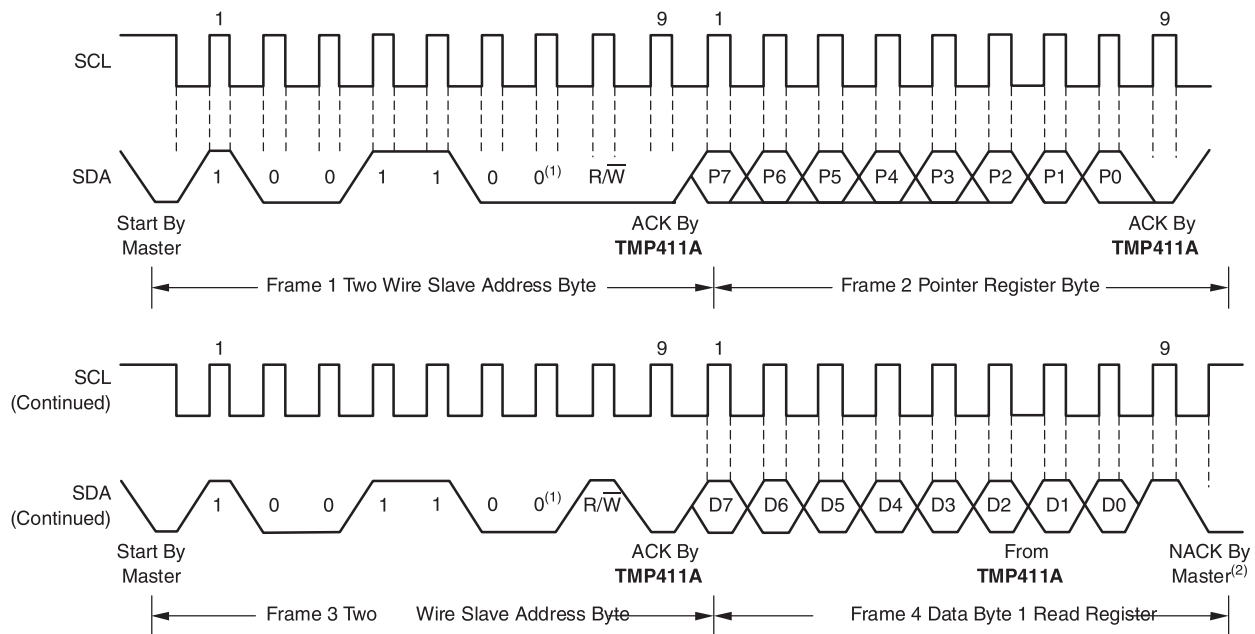

(1) Slave address 1001 100 (TMP411A and TMP411D) shown
 (2) Master should leave SDA high to terminate a single-byte read operation.

Figure 15. Two-Wire Timing Diagram for Single-Byte Read Format

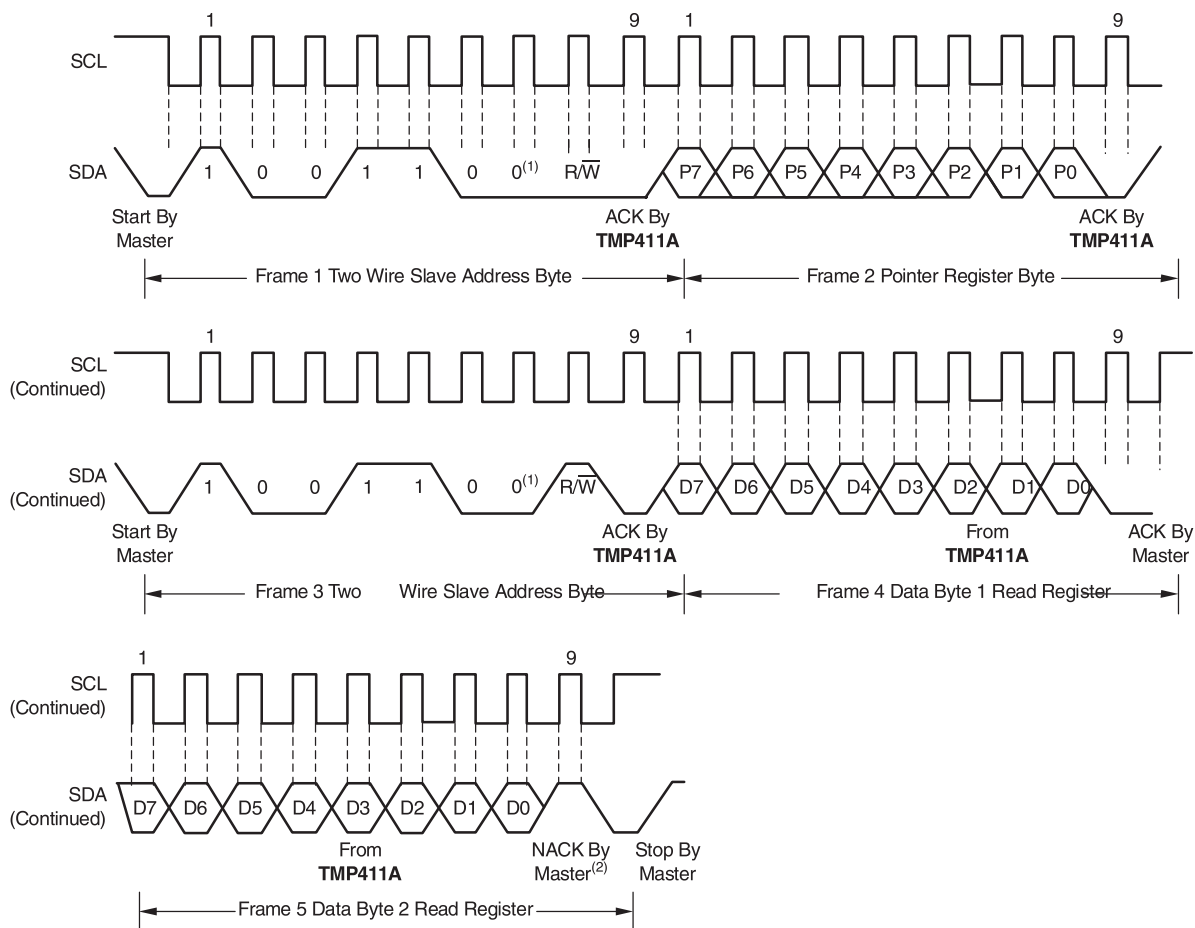

- (1) Slave address 1001 100 (TMP411A and TMP411D) shown
- (2) Master should leave SDA high to terminate a two-byte read operation.

Figure 16. Two-Wire Timing Diagram for Two-Byte Read Format

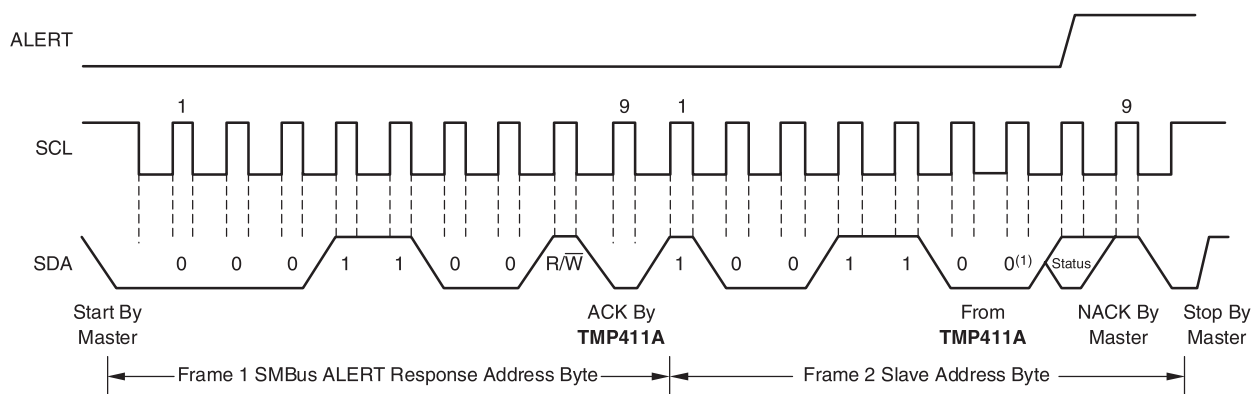

- (1) Slave address 1001 100 (TMP411A) shown

Figure 17. Timing Diagram for SMBus ALERT

HIGH-SPEED MODE

For the two-wire bus to operate at frequencies above 400 kHz, the master device must issue a high-speed mode (Hs-mode) master code (00001XXX) as the first byte after a START condition to switch the bus to high-speed operation. The TMP411-Q1 does not acknowledge this byte, but switches the input filters on SDA and SCL and the output filter on SDA to operate in Hs-mode, allowing transfers at up to 3.4 MHz. After the Hs-mode master code has been issued, the master transmits a two-wire slave address to initiate a data transfer operation. The bus continues to operate in Hs-mode until a STOP condition occurs on the bus. Upon receiving the STOP condition, the TMP411-Q1 switches the input and output filters back to fast-mode operation.

TIME-OUT FUNCTION

When bit 7 of the Consecutive Alert Register is set high, the TMP411-Q1 time-out function is enabled. The TMP411-Q1 resets the serial interface if either SCL or SDA is held low for 30 ms (typical) between a START and STOP condition. If the TMP411-Q1 is holding the bus low, it releases the bus and waits for a START condition. To avoid activating the time-out function, it is necessary to maintain a communication speed of at least 1 kHz for the SCL operating frequency. The default state of the time-out function is enabled (bit 7 = high).

THERM (PIN 4) AND ALERT/THERM2 (PIN 6)

The TMP411-Q1 has two pins dedicated to alarm functions, the THERM and ALERT/THERM2 pins. Both pins are open-drain outputs that each require a pullup resistor to V+. These pins can be wire-ORed together with other alarm pins for system monitoring of multiple sensors. The THERM pin provides a thermal interrupt that cannot be software-disabled. The ALERT pin is intended for use as an earlier warning interrupt, and can be software disabled, or

masked. The ALERT/THERM2 pin can also be configured for use as THERM2, a second THERM pin (Configuration Register: AL/TH bit = 1). The default setting configures pin 6 to function as ALERT (AL/TH = 0).

The THERM pin asserts low when either the measured local or remote temperature is outside of the temperature range programmed in the corresponding Local or Remote THERM Limit Register. The THERM temperature limit range can be programmed with a wider range than that of the limit registers, which allows ALERT to provide an earlier warning than THERM. The THERM alarm resets automatically when the measured temperature returns to within the THERM temperature limit range minus the hysteresis value stored in the THERM Hysteresis Register. The allowable values of hysteresis are shown in Table 11. The default hysteresis is 10°C. When the ALERT/THERM2 pin is configured as a second thermal alarm (Configuration Register: bit 7 = 0, bit 5 = 1), it functions the same as THERM, but uses the temperatures stored in the Local/Remote Temperature High/Low Limit Registers to set its comparison range.

When ALERT/THERM2 (pin 6) is configured as ALERT (Configuration Register: bit 7 = 0, bit 5 = 0), the pin asserts low when either the measured local or remote temperature violates the range limit set by the corresponding Local/Remote Temperature High/Low Limit Registers. This alert function can be configured to assert only if the range is violated a specified number of consecutive times (1, 2, 3, or 4). The consecutive violation limit is set in the Consecutive Alert Register. False alerts that occur as a result of environmental noise can be prevented by requiring consecutive faults. ALERT also asserts low if the remote temperature sensor is open-circuit. When the MASK function is enabled (Configuration Register: bit 7 = 1), ALERT is disabled (that is, masked). ALERT resets when the master reads the device address, as long as the condition that caused the alert no longer persists, and the Status Register has been reset.

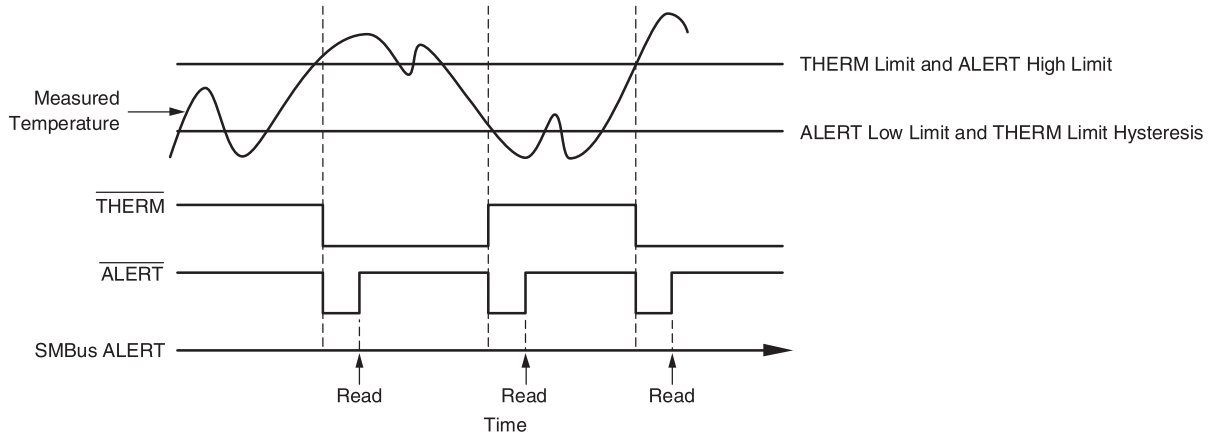

Figure 18. SMBus Alert Timing Diagram

SMBUS ALERT FUNCTION

The TMP411-Q1 supports the SMBus alert function. When pin 6 is configured as an alert output, the ALERT pin of the TMP411-Q1 may be connected as an SMBus alert signal. When a master detects an alert condition on the ALERT line, the master sends an SMBus alert command (0001 1001) on the bus. If the ALERT pin of the TMP411-Q1 is active, the device acknowledges the SMBus alert command and responds by returning its slave address on the SDA line. The eighth bit (LSB) of the slave address byte indicates whether the temperature exceeding one of the temperature high limit settings or falling below one of the temperature low limit settings caused the alert condition. This bit will be high if the temperature is greater than or equal to one of the temperature high-limit settings; this bit is low if the temperature is less than one of the temperature low-limit settings. See [Figure 17](#) for details of this sequence.

If multiple devices on the bus respond to the SMBus alert command, arbitration during the slave address portion of the SMBus alert command determines which device clears its alert status. If the TMP411-Q1 wins the arbitration, its ALERT pin becomes inactive at the completion of the SMBus alert command. If the TMP411-Q1 loses the arbitration, the ALERT pin remains active.

SHUTDOWN MODE (SD)

The TMP411-Q1 shutdown mode allows the user to save maximum power by shutting down all device circuitry other than the serial interface, reducing current consumption to typically less than 3 μ A; see typical characteristic curve Shutdown Quiescent Current vs Supply Voltage. Shutdown mode is enabled when the SD bit of the Configuration Register is high; the device shuts down once the current conversion is completed. When SD is low, the device maintains a continuous conversion state.

SENSOR FAULT

The TMP411-Q1 senses a fault at the D+ input resulting from incorrect diode connection or an open circuit. The detection circuitry consists of a voltage comparator that trips when the voltage at D+ exceeds (V+) – 0.6 V (typical). The comparator output is continuously checked during a conversion. If a fault is detected, the last valid measured temperature is used for the temperature measurement result, the OPEN bit (Status Register, bit 2) is set high, and, if the alert function is enabled, ALERT asserts low.

When not using the remote sensor with the TMP411-Q1, the D+ and D– inputs must be connected together to prevent meaningless fault warnings.

UNDERVOLTAGE LOCKOUT

The TMP411-Q1 senses when the power-supply voltage has reached a minimum voltage level for the ADC converter to function. The detection circuitry consists of a voltage comparator that enables the ADC converter after the power supply (V+) exceeds 2.45 V (typical). The comparator output is continuously checked during a conversion. The TMP411-Q1 does not perform a temperature conversion if the power-supply output is not adequate. The last valid measured temperature is used for the temperature measurement result.

GENERAL-CALL RESET

The TMP411-Q1 supports reset via the two-wire general-call address 00h (0000 0000b). The TMP411-Q1 acknowledges the general-call address and responds to the second byte. If the second byte is 06h (0000 0110b), the TMP411-Q1 executes a software reset. This software reset restores the power-on-reset state to all TMP411-Q1 registers, aborts any conversion in progress, and clears the ALERT and THERM pins. The TMP411-Q1 takes no action in response to other values in the second byte.

IDENTIFICATION REGISTERS

The TMP411-Q1 allows for the two-wire bus controller to query the device for manufacturer and device IDs. This feature allows for software identification of the device at the particular two-wire bus address. The manufacturer ID is obtained by reading from pointer address FEh. The TMP411-Q1 manufacturer code is 55h. The device ID depends on the specific model; see the Register Map ([Table 4](#)). These registers are read-only.

FILTERING

Remote junction temperature sensors are usually implemented in a noisy environment. Noise is most often created by fast digital signals, and it can corrupt measurements. The TMP411-Q1 has a built-in 65-kHz filter on the inputs of D+ and D– to minimize the effects of noise. However, a bypass capacitor placed differentially across the inputs of the remote temperature sensor is recommended to make the application more robust against unwanted coupled signals. The value of the capacitor should be between 100 pF and 1 nF. Some applications attain better overall accuracy with additional series resistance; however, this increased accuracy is setup-specific. When series resistance is added, the value should not be greater than 3 k Ω .

If filtering is needed, the suggested component values are 100 pF and 50 Ω on each input. Exact values are application-specific.

REMOTE SENSING

The TMP411-Q1 is designed to be used with either discrete transistors or substrate transistors built into processor chips and ASICs. Either NPN or PNP transistors can be used, as long as the base-emitter junction is used as the remote temperature sense. Either a transistor or diode connection can also be used; see [Figure 11](#).

Errors in remote temperature-sensor readings are the consequence of the ideality factor and current excitation used by the TMP411-Q1 versus the manufacturer-specified operating current for a given transistor. Some manufacturers specify a high-level and low-level current for the temperature-sensing substrate transistors. The TMP411-Q1 uses 6 μA for I_{LOW} and 120 μA for I_{HIGH} . The TMP411-Q1 allows for different n-factor values; see the N-Factor Correction Register section.

The ideality factor (n) is a measured characteristic of a remote temperature sensor diode as compared to an ideal diode. The ideality factor for the TMP411-Q1 is trimmed to be 1.008. For transistors whose ideality factor does not match the TMP411-Q1, [Equation 4](#) can be used to calculate the temperature error. Note that for the equation to be used correctly, actual temperature ($^{\circ}\text{C}$) must be converted to Kelvin (K).

$$T_{\text{ERR}} = \left(\frac{n - 1.008}{1.008} \right) \times (273.15 + T(^{\circ}\text{C})) \quad (4)$$

where:

n = Ideality factor of remote temperature sensor

T($^{\circ}\text{C}$) = actual temperature

T_{ERR} = Error in TMP411-Q1 reading due to n \neq 1.008

Degree delta is the same for $^{\circ}\text{C}$ and $^{\circ}\text{K}$

For n = 1.004 and T($^{\circ}\text{C}$) = 100 $^{\circ}\text{C}$:

$$T_{\text{ERR}} = \left(\frac{1.004 - 1.008}{1.008} \right) \times (273.15 + 100^{\circ}\text{C})$$

$$T_{\text{ERR}} = -1.48^{\circ}\text{C} \quad (5)$$

If a discrete transistor is used as the remote temperature sensor with the TMP411-Q1, the best accuracy can be achieved by selecting the transistor according to the following criteria:

1. Base-emitter voltage > 0.25 V at 6 μA , at the highest sensed temperature.
2. Base-emitter voltage < 0.95 V at 120 μA , at the lowest sensed temperature.
3. Base resistance < 100 Ω .

4. Tight control of V_{BE} characteristics indicated by small variations in h_{FE} (that is, 50 to 150).

Based on these criteria, two recommended small-signal transistors are the 2N3904 (NPN) or 2N3906 (PNP).

MEASUREMENT ACCURACY AND THERMAL CONSIDERATIONS

The temperature measurement accuracy of the TMP411-Q1 depends on the remote and/or local temperature sensor being at the same temperature as the system point being monitored. Clearly, if the temperature sensor is not in good thermal contact with the part of the system being monitored, then there is a delay in the response of the sensor to a temperature change in the system. For remote temperature sensing applications using a substrate transistor (or a small, SOT23 transistor) placed close to the device being monitored, this delay is usually not a concern.

The local temperature sensor inside the TMP411-Q1 monitors the ambient air around the device. The thermal time constant for the TMP411-Q1 is approximately two seconds. This constant implies that if the ambient air changes quickly by 100 $^{\circ}\text{C}$, it would take the TMP411-Q1 about 10 seconds (that is, five thermal time constants) to settle to within 1 $^{\circ}\text{C}$ of the final value. In most applications, the TMP411-Q1 package is in electrical and therefore thermal contact with the printed circuit board (PCB), as well as subjected to forced airflow. The accuracy of the measured temperature directly depends on how accurately the PCB and forced airflow temperatures represent the temperature that the TMP411-Q1 is measuring. Additionally, the internal power dissipation of the TMP411-Q1 can cause the temperature to rise above the ambient or PCB temperature. The internal power dissipated as a result of exciting the remote temperature sensor is negligible because of the small currents used. For a 5.5-V supply and maximum conversion rate of eight conversions per second, the TMP411-Q1 dissipates 1.82 mW ($\text{PD}_{\text{IQ}} = 5.5 \text{ V} \times 330 \mu\text{A}$). If both the ALERT/THERM2 and THERM pins are each sinking 1 mA, an additional power of 0.8 mW is dissipated ($\text{PD}_{\text{OUT}} = 1 \text{ mA} \times 0.4 \text{ V} + 1 \text{ mA} \times 0.4 \text{ V} = 0.8 \text{ mW}$). Total power dissipation is then 2.62 mW ($\text{PD}_{\text{IQ}} + \text{PD}_{\text{OUT}}$) and, with a θ_{JA} of 150 $^{\circ}\text{C}/\text{W}$, causes the junction temperature to rise approximately 0.393 $^{\circ}\text{C}$ above the ambient.

LAYOUT CONSIDERATIONS

Remote temperature sensing on the TMP411-Q1 measures very small voltages using very low currents; therefore, noise at the IC inputs must be minimized. Most applications using the TMP411-Q1 have high digital content, with several clocks and logic-level transitions creating a noisy environment. Layout should adhere to the following guidelines:

1. Place the TMP411-Q1 as close to the remote junction sensor as possible.
2. Route the D+ and D- traces next to each other and shield them from adjacent signals through the use of ground guard traces, as shown in Figure 19. If a multilayer PCB is used, bury these traces between ground or VDD planes to shield them from extrinsic noise sources. Five-mil (0.127-mm) PCB traces are recommended.
3. Minimize additional thermocouple junctions caused by copper-to-solder connections. If these junctions are used, make the same number and approximate locations of copper-to-solder connections in both the D+ and D- connections to cancel any thermocouple effects.
4. Use a 0.1- μ F local bypass capacitor directly between the V+ and GND of the TMP411-Q1, as shown in Figure 20. Minimize filter capacitance between D+ and D- to 1000 pF or less for optimum measurement performance. This capacitance includes any cable capacitance between the remote temperature sensor and TMP411-Q1.
5. If the connection between the remote temperature sensor and the TMP411-Q1 is less than 8 inches (20 cm), use a twisted-wire pair connection. Beyond 8 inches (20 cm), use a twisted, shielded pair with the shield grounded as close to the TMP411-Q1 as possible. Leave the remote sensor connection end of the shield wire open to avoid ground loops and 60-Hz pickup.

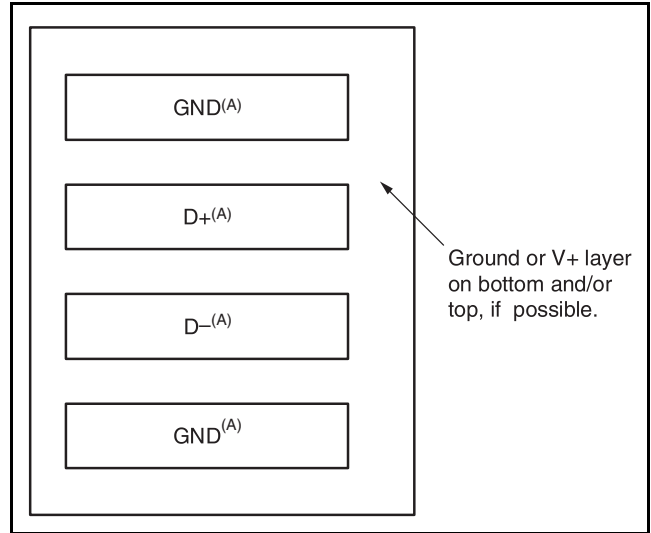

A. 5-mil (0.127-mm) traces with 5-mil (0.127-mm) spacing

Figure 19. Example Signal Traces

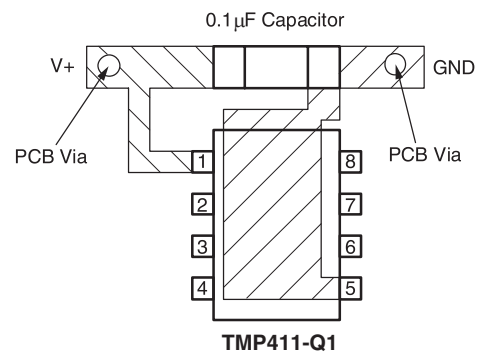

Figure 20. Suggested Bypass Capacitor Placement

REVISION HISTORY

The following table summarizes the revisions of the TMP411-Q1 Data Sheet.

Note: numbering may vary from previous versions.

Table 14. Revision History

Revision	Literature Number	Date	Notes
*	SBOS527	December, 2010	See ⁽¹⁾
A	SBOS527A	March, 2012	See ⁽²⁾
B	SBOS527B	August, 2012	See ⁽³⁾
C	SBOS527C	September, 2012	See ⁽⁴⁾
D	SBOS527D	October, 2012	See ⁽⁵⁾

- (1) TMP411-Q1 Data Sheet, (SBOS527) – initial release.
- (2) TMP411-Q1 Data Sheet, (SBOS527A):
 - (a) Removed all existing [Applications](#), and added automotive.
 - (b) Changed the [Ordering Information Table](#). Removed Preview devices TMP411xQDRQ1, and added device TMP411DQDGKRQ1
- (3) TMP411-Q1 Data Sheet, (SBOS527B):
 - (a) Added table note to [Ordering Information Table](#), and added default to the Local Temperature High Limit column header.
 - (b) Added another column to [Table 4](#): Power-on Reset (HEX) for D.
- (4) TMP411-Q1 Data Sheet, (SBOS527C):
 - (a) Removed part of sentence from [Description](#): "wide remote temperature measurement range (up to 150°C)".
 - (b) Changed extended Default Local Temperature High Limit to standard, and removed extended table note and package columns in the [Ordering Information Table](#).
 - (c) Removed the last two sentences in the first paragraph in the [Temperature Measurement Data](#) section; also added "which is referred to as standard temperature mode."
 - (d) Removed paragraph after "Likewise, temperatures above 127°C result in a value of 127 (7Fh)." in the [Temperature Measurement Data](#) section.
 - (e) Removed Extended Binary columns from [Table 2](#) and first paragraph beginning with "Note:" underneath the table.
 - (f) Removed "AND EXTENDED" from columns in [Table 3](#).
 - (g) Added the sentence "Please note read pointer address 0x05, 0x07, 0x19, and 0x20 have different power-on-reset values for A, B, C vs D" before last sentence in the [Pointer Register](#) section.
 - (h) Added space in between One and Shot in [Figure 12](#) so it reads One Shot Register instead of OneShot Register.
 - (i) Changed last sentence of first, and third paragraph, and the sixth sentence of the last paragraph in the [Limit Registers](#) section to: "The power-on-reset value of the local-temperature high limit is 55h for TMP411A-Q1 and 6Eh for TMP411D-Q1 (85°C for TMP411A-Q1 and 110°C for TMP411D-Q1)"
 - (j) Removed "-64°C in extended mode" from the second and fourth paragraphs in the [Limit Registers](#) section.
 - (k) Removed last paragraph in the [Limit Registers](#) section.
 - (l) Replaced last sentence of sixth paragraph in the [Configuration Register](#) section with "This bit is set to 0 by default and cannot be changed."
 - (m) Removed: 1 = -55°C to 150°C from temperature range row in [Table 6](#).
 - (n) Added "and TMP411D-Q1" to the second to last sentence in the [Serial Bus Address](#) section; removed last sentence.
 - (o) Updated layout of [Consecutive Alert Register](#) and [Therm Hysteresis Register](#) sections to make them easier to read.
 - (p) Fixed ALERT active low for I_{OH} in [Electrical Characteristics](#) table.
 - (q) Changed second to last sentence in the sixth paragraph of the [Configuration Register](#) section from: Setting this bit low configures the TMP411-Q1 for the standard measurement range (0°C to 127°C); temperature conversions are stored in the standard binary format, to: Setting this bit low configures the TMP411-Q1 for the standard measurement range (0°C to 127°C), and temperature conversions are stored in the standard binary format.
 - (r) Removed ", whether the device is operating in the standard or extended mode setting." from the last sentence in the [Therm Hysteresis Register](#) section.
- (5) TMP411-Q1 Data Sheet, (SBOS527D):
 - (a) Added Default Local High Temperature Limit and Default Remote High Temperature Limit columns to the [Ordering Information](#) table; changed last column header from Default Local Temperature High Limit to Default Temperature Range.

Table 14. Revision History (continued)

Revision	Literature Number	Date	Notes
E	SBOS527E	November, 2012	See ⁽⁶⁾

- (6) TMP411-Q1 Data Sheet, (SBOS527E):
 - (a) Added "wide remote temperature measurement range (up to 150°C)" back into the [Description](#) section.
 - (b) Removed ", which is referred to as standard temperature mode" in first paragraph of [Temperature Measurement Data](#) section.
 - (c) Added last two sentences of first paragraph back in to [Temperature Measurement Data](#) section.
 - (d) Added paragraph after "Likewise, temperatures above 127°C result in a value of 127 (7Fh)." back into [Temperature Measurement Data](#) section.
 - (e) Added Extended Binary columns back into [Table 2](#).
 - (f) Added note after [Table 2](#).
 - (g) Added "AND EXTENDED" back in to the STANDARD BINARY column headers in [Table 3](#).
 - (h) Replaced last sentence of first paragraph in [Limit Registers](#) section with: The power-on-reset value of the local temperature high limit is 55h/6Eh/00h (85°C in standard temperature mode for TMP411A-Q1 to TMP411C-Q1; 110°C in standard temperature mode for TMP411D-Q1, 21°C in extended temperature range).
 - (i) Added -64°C in extended mode back in to second and fourth paragraphs in [Limit Registers](#) section.
 - (j) Replaced last sentence of fourth paragraph in [Limit Registers](#) section with: The power-on-reset value of the Remote Temperature High Limit Register is 55h/6Eh/00h (85°C in standard temperature mode for TMP411A-Q1 to TMP411C-Q1; 110°C in standard temperature mode for TMP411D-Q1; 21°C in extended temperature mode).
 - (k) Replaced sentence in fifth paragraph of [Limit Registers](#) section with: The power-on-reset value of the $\overline{\text{THERM}}$ limit registers is 55h/6Eh/00h (85°C in standard temperature mode for TMP411A-Q1 to TMP411C-Q1; 110°C in standard temperature mode for TMP411D-Q1; 21°C in extended temperature mode).
 - (l) Added last paragraph back into the [Limit Registers](#) section.
 - (m) Replaced this sentence: This bit is set to 0 by default and cannot be changed, with this sentence: Setting bit 2 high configures the TMP411-Q1 for the extended measurement range (-55°C to 150°C) temperature conversions are stored in the extended binary format (see Table 1) in the [Configuration Register](#) section.
 - (n) Added note to [Configuration Register](#) section.
 - (o) Added 1 = -55°C to 150°C back to temperature range row in [Table 6](#).
 - (p) Added "whether the device is operating in the standard or extended mode setting" to last sentence in [Therm Hysteresis Register](#) section.

Table 14. Revision History (continued)

Revision	Literature Number	Date	Notes
F	SBOS527F	November, 2013	See ⁽⁷⁾

- (7) TMP411-Q1 Data Sheet, (SBOS527F):
- (a) Changed device CDM ESD Classification Level from C3B to C4B in [FEATURES](#) list item and in the [ABSOLUTE MAXIMUM RATINGS](#) table.
 - (b) Deleted T_A and Top-Side Marking columns from [Table 1](#).
 - (c) Changed package throughout document from MSOP to VSSOP.

PACKAGING INFORMATION

Orderable Device	Status (1)	Package Type	Package Drawing	Pins	Package Qty	Eco Plan (2)	Lead/Ball Finish (6)	MSL Peak Temp (3)	Op Temp (°C)	Device Marking (4/5)	Samples
TMP411AQDGKRQ1	ACTIVE	VSSOP	DGK	8	2500	Green (RoHS & no Sb/Br)	CU NIPDAU	Level-3-260C-168 HR		411AQ	Samples
TMP411BQDGKRQ1	ACTIVE	VSSOP	DGK	8	2500	Green (RoHS & no Sb/Br)	CU NIPDAUAG	Level-2-260C-1 YEAR	-40 to 125	411BQ	Samples
TMP411CQDGKRQ1	ACTIVE	VSSOP	DGK	8	2500	Green (RoHS & no Sb/Br)	CU NIPDAUAG	Level-2-260C-1 YEAR	-40 to 125	411CQ	Samples
TMP411DQDGKRQ1	ACTIVE	VSSOP	DGK	8	2500	Green (RoHS & no Sb/Br)	CU NIPDAU	Level-3-260C-168 HR	-40 to 125	411DQ	Samples

(1) The marketing status values are defined as follows:

ACTIVE: Product device recommended for new designs.

LIFEBUY: TI has announced that the device will be discontinued, and a lifetime-buy period is in effect.

NRND: Not recommended for new designs. Device is in production to support existing customers, but TI does not recommend using this part in a new design.

PREVIEW: Device has been announced but is not in production. Samples may or may not be available.

OBSOLETE: TI has discontinued the production of the device.

(2) Eco Plan - The planned eco-friendly classification: Pb-Free (RoHS), Pb-Free (RoHS Exempt), or Green (RoHS & no Sb/Br) - please check <http://www.ti.com/productcontent> for the latest availability information and additional product content details.

TBD: The Pb-Free/Green conversion plan has not been defined.

Pb-Free (RoHS): TI's terms "Lead-Free" or "Pb-Free" mean semiconductor products that are compatible with the current RoHS requirements for all 6 substances, including the requirement that lead not exceed 0.1% by weight in homogeneous materials. Where designed to be soldered at high temperatures, TI Pb-Free products are suitable for use in specified lead-free processes.

Pb-Free (RoHS Exempt): This component has a RoHS exemption for either 1) lead-based flip-chip solder bumps used between the die and package, or 2) lead-based die adhesive used between the die and leadframe. The component is otherwise considered Pb-Free (RoHS compatible) as defined above.

Green (RoHS & no Sb/Br): TI defines "Green" to mean Pb-Free (RoHS compatible), and free of Bromine (Br) and Antimony (Sb) based flame retardants (Br or Sb do not exceed 0.1% by weight in homogeneous material)

(3) MSL, Peak Temp. - The Moisture Sensitivity Level rating according to the JEDEC industry standard classifications, and peak solder temperature.

(4) There may be additional marking, which relates to the logo, the lot trace code information, or the environmental category on the device.

(5) Multiple Device Markings will be inside parentheses. Only one Device Marking contained in parentheses and separated by a "~" will appear on a device. If a line is indented then it is a continuation of the previous line and the two combined represent the entire Device Marking for that device.

(6) Lead/Ball Finish - Orderable Devices may have multiple material finish options. Finish options are separated by a vertical ruled line. Lead/Ball Finish values may wrap to two lines if the finish value exceeds the maximum column width.

Important Information and Disclaimer: The information provided on this page represents TI's knowledge and belief as of the date that it is provided. TI bases its knowledge and belief on information provided by third parties, and makes no representation or warranty as to the accuracy of such information. Efforts are underway to better integrate information from third parties. TI has taken and continues to take reasonable steps to provide representative and accurate information but may not have conducted destructive testing or chemical analysis on incoming materials and chemicals. TI and TI suppliers consider certain information to be proprietary, and thus CAS numbers and other limited information may not be available for release.

In no event shall TI's liability arising out of such information exceed the total purchase price of the TI part(s) at issue in this document sold by TI to Customer on an annual basis.

OTHER QUALIFIED VERSIONS OF TMP411-Q1 :

- Catalog: [TMP411](#)

NOTE: Qualified Version Definitions:

- Catalog - TI's standard catalog product

TAPE AND REEL INFORMATION

QUADRANT ASSIGNMENTS FOR PIN 1 ORIENTATION IN TAPE

*All dimensions are nominal

Device	Package Type	Package Drawing	Pins	SPQ	Reel Diameter (mm)	Reel Width W1 (mm)	A0 (mm)	B0 (mm)	K0 (mm)	P1 (mm)	W (mm)	Pin1 Quadrant
TMP411AQDGKRQ1	VSSOP	DGK	8	2500	330.0	12.4	5.3	3.3	1.3	8.0	12.0	Q1
TMP411BQDGKRQ1	VSSOP	DGK	8	2500	330.0	12.4	5.3	3.4	1.4	8.0	12.0	Q1
TMP411CQDGKRQ1	VSSOP	DGK	8	2500	330.0	12.4	5.3	3.4	1.4	8.0	12.0	Q1
TMP411DQDGKRQ1	VSSOP	DGK	8	2500	330.0	12.4	5.3	3.3	1.3	8.0	12.0	Q1

TAPE AND REEL BOX DIMENSIONS

*All dimensions are nominal

Device	Package Type	Package Drawing	Pins	SPQ	Length (mm)	Width (mm)	Height (mm)
TMP411AQDGKRQ1	VSSOP	DGK	8	2500	370.0	355.0	55.0
TMP411BQDGKRQ1	VSSOP	DGK	8	2500	366.0	364.0	50.0
TMP411CQDGKRQ1	VSSOP	DGK	8	2500	366.0	364.0	50.0
TMP411DQDGKRQ1	VSSOP	DGK	8	2500	370.0	355.0	55.0



- NOTES:
- A. All linear dimensions are in millimeters.
 - B. This drawing is subject to change without notice.
 - C. Publication IPC-7351 is recommended for alternate designs.
 - D. Laser cutting apertures with trapezoidal walls and also rounding corners will offer better paste release. Customers should contact their board assembly site for stencil design recommendations. Refer to IPC-7525 for other stencil recommendations.
 - E. Customers should contact their board fabrication site for solder mask tolerances between and around signal pads.

IMPORTANT NOTICE

Texas Instruments Incorporated (TI) reserves the right to make corrections, enhancements, improvements and other changes to its semiconductor products and services per JESD46, latest issue, and to discontinue any product or service per JESD48, latest issue. Buyers should obtain the latest relevant information before placing orders and should verify that such information is current and complete.

TI's published terms of sale for semiconductor products (<http://www.ti.com/sc/docs/stdterms.htm>) apply to the sale of packaged integrated circuit products that TI has qualified and released to market. Additional terms may apply to the use or sale of other types of TI products and services.

Reproduction of significant portions of TI information in TI data sheets is permissible only if reproduction is without alteration and is accompanied by all associated warranties, conditions, limitations, and notices. TI is not responsible or liable for such reproduced documentation. Information of third parties may be subject to additional restrictions. Resale of TI products or services with statements different from or beyond the parameters stated by TI for that product or service voids all express and any implied warranties for the associated TI product or service and is an unfair and deceptive business practice. TI is not responsible or liable for any such statements.

Buyers and others who are developing systems that incorporate TI products (collectively, "Designers") understand and agree that Designers remain responsible for using their independent analysis, evaluation and judgment in designing their applications and that Designers have full and exclusive responsibility to assure the safety of Designers' applications and compliance of their applications (and of all TI products used in or for Designers' applications) with all applicable regulations, laws and other applicable requirements. Designer represents that, with respect to their applications, Designer has all the necessary expertise to create and implement safeguards that (1) anticipate dangerous consequences of failures, (2) monitor failures and their consequences, and (3) lessen the likelihood of failures that might cause harm and take appropriate actions. Designer agrees that prior to using or distributing any applications that include TI products, Designer will thoroughly test such applications and the functionality of such TI products as used in such applications.

TI's provision of technical, application or other design advice, quality characterization, reliability data or other services or information, including, but not limited to, reference designs and materials relating to evaluation modules, (collectively, "TI Resources") are intended to assist designers who are developing applications that incorporate TI products; by downloading, accessing or using TI Resources in any way, Designer (individually or, if Designer is acting on behalf of a company, Designer's company) agrees to use any particular TI Resource solely for this purpose and subject to the terms of this Notice.

TI's provision of TI Resources does not expand or otherwise alter TI's applicable published warranties or warranty disclaimers for TI products, and no additional obligations or liabilities arise from TI providing such TI Resources. TI reserves the right to make corrections, enhancements, improvements and other changes to its TI Resources. TI has not conducted any testing other than that specifically described in the published documentation for a particular TI Resource.

Designer is authorized to use, copy and modify any individual TI Resource only in connection with the development of applications that include the TI product(s) identified in such TI Resource. NO OTHER LICENSE, EXPRESS OR IMPLIED, BY ESTOPPEL OR OTHERWISE TO ANY OTHER TI INTELLECTUAL PROPERTY RIGHT, AND NO LICENSE TO ANY TECHNOLOGY OR INTELLECTUAL PROPERTY RIGHT OF TI OR ANY THIRD PARTY IS GRANTED HEREIN, including but not limited to any patent right, copyright, mask work right, or other intellectual property right relating to any combination, machine, or process in which TI products or services are used. Information regarding or referencing third-party products or services does not constitute a license to use such products or services, or a warranty or endorsement thereof. Use of TI Resources may require a license from a third party under the patents or other intellectual property of the third party, or a license from TI under the patents or other intellectual property of TI.

TI RESOURCES ARE PROVIDED "AS IS" AND WITH ALL FAULTS. TI DISCLAIMS ALL OTHER WARRANTIES OR REPRESENTATIONS, EXPRESS OR IMPLIED, REGARDING RESOURCES OR USE THEREOF, INCLUDING BUT NOT LIMITED TO ACCURACY OR COMPLETENESS, TITLE, ANY EPIDEMIC FAILURE WARRANTY AND ANY IMPLIED WARRANTIES OF MERCHANTABILITY, FITNESS FOR A PARTICULAR PURPOSE, AND NON-INFRINGEMENT OF ANY THIRD PARTY INTELLECTUAL PROPERTY RIGHTS. TI SHALL NOT BE LIABLE FOR AND SHALL NOT DEFEND OR INDEMNIFY DESIGNER AGAINST ANY CLAIM, INCLUDING BUT NOT LIMITED TO ANY INFRINGEMENT CLAIM THAT RELATES TO OR IS BASED ON ANY COMBINATION OF PRODUCTS EVEN IF DESCRIBED IN TI RESOURCES OR OTHERWISE. IN NO EVENT SHALL TI BE LIABLE FOR ANY ACTUAL, DIRECT, SPECIAL, COLLATERAL, INDIRECT, PUNITIVE, INCIDENTAL, CONSEQUENTIAL OR EXEMPLARY DAMAGES IN CONNECTION WITH OR ARISING OUT OF TI RESOURCES OR USE THEREOF, AND REGARDLESS OF WHETHER TI HAS BEEN ADVISED OF THE POSSIBILITY OF SUCH DAMAGES.

Unless TI has explicitly designated an individual product as meeting the requirements of a particular industry standard (e.g., ISO/TS 16949 and ISO 26262), TI is not responsible for any failure to meet such industry standard requirements.

Where TI specifically promotes products as facilitating functional safety or as compliant with industry functional safety standards, such products are intended to help enable customers to design and create their own applications that meet applicable functional safety standards and requirements. Using products in an application does not by itself establish any safety features in the application. Designers must ensure compliance with safety-related requirements and standards applicable to their applications. Designer may not use any TI products in life-critical medical equipment unless authorized officers of the parties have executed a special contract specifically governing such use. Life-critical medical equipment is medical equipment where failure of such equipment would cause serious bodily injury or death (e.g., life support, pacemakers, defibrillators, heart pumps, neurostimulators, and implantables). Such equipment includes, without limitation, all medical devices identified by the U.S. Food and Drug Administration as Class III devices and equivalent classifications outside the U.S.

TI may expressly designate certain products as completing a particular qualification (e.g., Q100, Military Grade, or Enhanced Product). Designers agree that it has the necessary expertise to select the product with the appropriate qualification designation for their applications and that proper product selection is at Designers' own risk. Designers are solely responsible for compliance with all legal and regulatory requirements in connection with such selection.

Designer will fully indemnify TI and its representatives against any damages, costs, losses, and/or liabilities arising out of Designer's non-compliance with the terms and provisions of this Notice.

Looking for pricing, stock, or lifecycle information?

Click below to explore more details on WIN SOURCE:

 [View TMP411AQDGKRQ1 on WIN SOURCE](#)

 [Texas Instruments](#) Information

Optimize Your Supply Chain with WIN SOURCE Solutions

-  Global Sourcing Solution
-  Obsolete Management
-  Cost Control Management
-  Shortage Management
-  Alternative Solution
-  Excess Inventory Management