



THE DATASHEET OF ADT7460ARQ-REEL



FEATURES

- Controls and monitors up to 4 fan speeds**
- 1 on-chip and 2 remote temperature sensors**
- Dynamic T_{MIN} control mode optimizes system acoustics intelligently**
- Automatic fan speed control mode controls system cooling based on measured temperature**
- Enhanced acoustic mode dramatically reduces user perception of changing fan speeds**
- Thermal protection feature via THERM output**
- Monitors performance impact of Intel® Pentium® 4 Processor thermal control circuit via THERM input**
- 2-wire and 3-wire fan speed measurement**
- Limit comparison of all monitored values**
- Meets SMBus 2.0 electrical specifications (fully SMBus 1.1-compliant)**

APPLICATIONS

- Low acoustic noise PCs**
- Networking and telecommunications equipment**

GENERAL DESCRIPTION

The ADT7460¹ dBCOOL controller is a thermal monitor and multiple PWM fan controller for noise-sensitive applications requiring active system cooling. It can monitor the temperature of up to two remote sensor diodes plus its own internal temperature. It can measure and control the speed of up to four fans so that they operate at the lowest possible speed for minimum acoustic noise. The automatic fan speed control loop optimizes fan speed for a given temperature. A unique dynamic T_{MIN} control mode enables the system thermals/acoustics to be intelligently managed. The effectiveness of the system's thermal solution can be monitored using the THERM input. The ADT7460 also provides critical thermal protection to the system by using the bidirectional THERM pin as an output to prevent system or component overheating.

FUNCTIONAL BLOCK DIAGRAM

Figure 1.

¹Protected by U.S. Patent Nos. 6,188,189; 6,169,442; 6,097,239; 5,982,221; and 5,867,012. Other patents pending.

Rev. C

Information furnished by Analog Devices is believed to be accurate and reliable. However, no responsibility is assumed by Analog Devices for its use, nor for any infringements of patents or other rights of third parties that may result from its use. Specifications subject to change without notice. No license is granted by implication or otherwise under any patent or patent rights of Analog Devices. Trademarks and registered trademarks are the property of their respective owners.

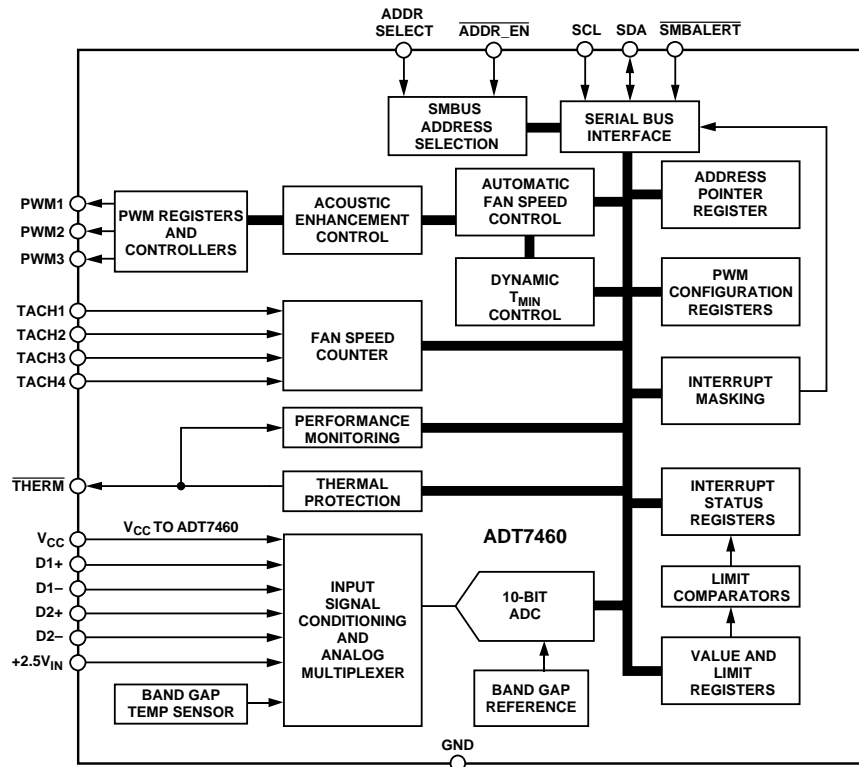
TABLE OF CONTENTS

Specifications.....	3	Additional ADC Functions for Voltage Measurements.....	17
Absolute Maximum Ratings.....	5	Temperature Measurement System.....	17
Thermal Characteristics	5	Additional ADC Functions for Temperature Measurement	19
ESD Caution.....	5	Limits, Status Registers, and Interrupts.....	20
Pin Configuration and Function Descriptions.....	6	Status Registers	21
Typical Performance Characteristics	7	Handling $\overline{\text{SMBALERT}}$ Interrupts.....	22
Product Description.....	9	$\overline{\text{THERM}}$ Timer	24
Measurement Inputs	9	Fan Drive Using PWM Control	27
Sequential Measurement	9	Operating from 3.3 V Standby	33
Recommended Implementation.....	9	XNOR Tree Test Mode	33
ADT7460 Address Selection	10	Power-On Default	33
Internal Registers of the ADT7460	10	ADT7460 Register Summary.....	34
Theory of Operation	11	Outline Dimensions	51
Serial Bus Interface.....	11	Ordering Guide	51
Voltage Measurement Input.....	15		

REVISION HISTORY

3/05—Rev. B to Rev. C

Updated Format.....	Universal
Changes to Absolute Maximum Ratings Table.....	5
Changes to ADT7460 Register Map Summary Section	34
Updated Ordering Guide.....	51

9/03—Rev. A to Rev. B

Changed XOR Tree Test Mode to XNOR	Universal
Changes to SPECIFICATIONS.....	2
Changes to TPC 7	7

6/03—Rev. 0 to Rev. A

Updated ORDERING	4
Updated the SERIAL BUS INTERFACE section.....	9
Added the To Assign $\overline{\text{THERM}}$ Functionality to a Pin 9 section	21
Added the $\overline{\text{THERM}}$ as an Input section.....	21
Renamed the Therm Input section to $\overline{\text{THERM}}$ Timer	21
Renumbered the figures after Figure 25.....	22
Updated Step 1 in the Configuring the Desired $\overline{\text{THERM}}$ Behavior section.....	2
Updated the Fan Speed Control section	28
Added the POWER-ON DEFAULT section	29
Updated Table IV	30
Updated Table XVIII	38
Updated Table XX.....	40
Updated Table XXXV	46
Updated OUTLINE DIMENSIONS	49

SPECIFICATIONS

$T_A = T_{MIN}$ to T_{MAX} , $V_{CC} = V_{MIN}$ to V_{MAX} , unless otherwise noted.

Table 1.

Parameter ^{1,2,3}	Min	Typ ⁴	Max	Unit	Test Conditions/Comments
POWER SUPPLY					
Supply Voltage	3.0	5.0	5.5	V	Interface inactive, ADC active Standby mode
Supply Current, I_{CC}			3	mA	
			20	μ A	
TEMPERATURE-TO-DIGITAL CONVERTER					
Local Sensor Accuracy			± 1.5	$^{\circ}$ C	$0^{\circ}\text{C} \leq T_A \leq 70^{\circ}\text{C}$
			± 3	$^{\circ}$ C	$-40^{\circ}\text{C} \leq T_A \leq +120^{\circ}\text{C}$
Resolution		0.25		$^{\circ}$ C	
Remote Diode Sensor Accuracy			± 1.5	$^{\circ}$ C	$0^{\circ}\text{C} \leq T_A \leq 70^{\circ}\text{C}; 0^{\circ}\text{C} \leq T_D \leq 120^{\circ}\text{C}$
			± 2.5	$^{\circ}$ C	$0^{\circ}\text{C} \leq T_A \leq 105^{\circ}\text{C}; 0^{\circ}\text{C} \leq T_D \leq 120^{\circ}\text{C}$
			± 3	$^{\circ}$ C	$0^{\circ}\text{C} \leq T_A \leq 120^{\circ}\text{C}; 0^{\circ}\text{C} \leq T_D \leq 120^{\circ}\text{C}$
Resolution		0.25		$^{\circ}$ C	
Remote Sensor Source Current		180		μ A	High level
		11		μ A	Low level
ANALOG-TO-DIGITAL CONVERTER (INCLUDING MUX AND ATTENUATORS)					
Total Unadjusted Error, TUE			± 1.5	%	8 bits
Differential Nonlinearity, DNL			± 1	LSB	
Power Supply Sensitivity		± 0.1		%/V	
Conversion Time (Voltage Input)		11.38	13	ms	Averaging enabled
Conversion Time (Local Temperature)		12.09	13.50	ms	Averaging enabled
Conversion Time (Remote Temperature)		25.59	28	ms	Averaging enabled
Total Monitoring Cycle Time		120.17	134.50	ms	Averaging enabled (incl. delay ⁵)
		13.51	15	ms	Averaging disabled
Input Resistance	80	140	200	k Ω	
FAN RPM-TO-DIGITAL CONVERTER					
Accuracy			± 7	%	$0^{\circ}\text{C} \leq T_A \leq 70^{\circ}\text{C}$
			± 11	%	$0^{\circ}\text{C} \leq T_A \leq 105^{\circ}\text{C}$
			± 13	%	$-40^{\circ}\text{C} \leq T_A \leq +120^{\circ}\text{C}$
Full-Scale Count			65,535		
Nominal Input RPM		109		RPM	Fan count = 0xBFFF
		329		RPM	Fan count = 0x3FFF
		5000		RPM	Fan count = 0x0438
		10000		RPM	Fan count = 0x021C
Internal Clock Frequency	82.8	90.0	97.2	kHz	
OPEN-DRAIN DIGITAL OUTPUTS, PWM1–PWM3, XTO					
Current Sink, I_{OL}			8.0	mA	$I_{OUT} = -8.0$ mA, $V_{CC} = 3.3$ V $V_{OUT} = V_{CC}$
Output Low Voltage, V_{OL}			0.4	V	
High Level Output Current, I_{OH}		0.1	1	μ A	
OPEN-DRAIN SERIAL DATA BUS OUTPUT (SDA)					
Output Low Voltage, V_{OL}			0.4	V	$I_{OUT} = -4.0$ mA, $V_{CC} = 3.3$ V $V_{OUT} = V_{CC}$
High Level Output Current, I_{OH}		0.1	1	μ A	
SMBUS DIGITAL INPUTS (SCL, SDA)					
Input High Voltage, V_{IH}	2.0			V	
Input Low Voltage, V_{IL}			0.4	V	
Hysteresis		500		mV	

ADT7460

Parameter ^{1, 2, 3}	Min	Typ ⁴	Max	Unit	Test Conditions/Comments
DIGITAL INPUT LOGIC LEVELS (TACH INPUTS)					
Input High Voltage, V_{IH}	2.0		5.5	V	Maximum input voltage
Input Low Voltage, V_{IL}			+0.8	V	
Hysteresis	-0.3	0.5		V p-p	Minimum input voltage
DIGITAL INPUT LOGIC LEVELS (THERM)					
Input High Voltage, V_{IH}	1.7			V	
Input Low Voltage, V_{IL}			0.8	V	
DIGITAL INPUT CURRENT					
Input High Current, I_{IH}	-1			μ A	$V_{IN} = V_{CC}$
Input Low Current, I_{IL}			+1	μ A	$V_{IN} = 0$
Input Capacitance, C_{IN}		5		pF	
SERIAL BUS TIMING ⁶					
Clock Frequency, f_{SCLK}			400	kHz	See Figure 2
Glitch Immunity, t_{SW}			50	ns	
Bus Free Time, t_{BUF}	1.3			μ s	See Figure 2
Start Setup Time, $t_{SU;STA}$	0.6			μ s	See Figure 2
Start Hold Time, $t_{HD;STA}$	0.6			μ s	See Figure 2
SCL Low Time, t_{LOW}	1.3			μ s	See Figure 2
SCL High Time, t_{HIGH}	0.6			μ s	See Figure 2
SCL, SDA Rise Time, t_R			300	ns	See Figure 2
SCL, SDA Fall Time, t_F			300	μ s	See Figure 2
Data Setup Time, $t_{SU;DAT}$	100			ns	See Figure 2
Detect Clock Low Timeout, $t_{TIMEOUT}$	15		35	ms	Can be optionally disabled

¹ All voltages are measured with respect to GND, unless otherwise specified.

² Logic inputs accept input high voltages up to V_{MAX} even when the device is operating down to V_{MIN} .

³ Timing specifications are tested at logic levels of $V_{IL} = 0.8$ V for a falling edge and at $V_{IH} = 2.0$ V for a rising edge.

⁴ Typicals are at $T_A = 25^\circ\text{C}$ and represent the most likely parametric norm.

⁵ The delay is the time between the round robin finishing one set of measurements and starting the next.

⁶ Guaranteed by design, not production tested.

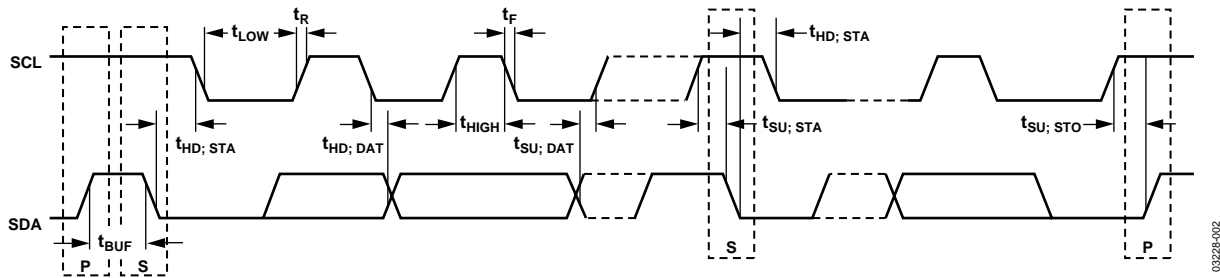

Figure 2. Serial Bus Timing Diagram

ABSOLUTE MAXIMUM RATINGS

Table 2.

Parameter	Rating
Positive Supply Voltage (V_{CC})	6.5 V
Voltage on Any Other Input or Output Pin	-0.3 V to +6.5 V
Input Current at Any Pin	± 5 mA
Package Input Current	± 20 mA
Maximum Junction Temperature (T_J max)	150°C
Storage Temperature Range	-65°C to +150°C
Lead Temperature, Soldering	
IR Reflow Peak Temperature	220°C
IR Reflow Peak Temperature for Pb Free	260°C
Lead Temperature (Soldering 10 s)	300°C
ESD Rating	1500 V

Stresses above those listed under Absolute Maximum Ratings may cause permanent damage to the device. This is a stress rating only; functional operation of the device at these or any other conditions above those indicated in the operational section of this specification is not implied. Exposure to absolute maximum rating conditions for extended periods may affect device reliability.

THERMAL CHARACTERISTICS

16-Lead QSOP Package:

$$\theta_{JA} = 150^{\circ}\text{C}/\text{W}$$

$$\theta_{JC} = 39^{\circ}\text{C}/\text{W}$$

ESD CAUTION

ESD (electrostatic discharge) sensitive device. Electrostatic charges as high as 4000 V readily accumulate on the human body and test equipment and can discharge without detection. Although this product features proprietary ESD protection circuitry, permanent damage may occur on devices subjected to high energy electrostatic discharges. Therefore, proper ESD precautions are recommended to avoid performance degradation or loss of functionality.



PIN CONFIGURATION AND FUNCTION DESCRIPTIONS

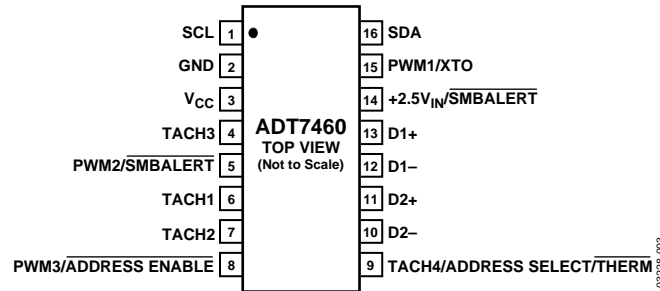

Figure 3. Pin Configuration

Table 3. Pin Function Descriptions

Pin No.	Mnemonic	Description
1	SCL	Digital Input (Open Drain). SMBus serial clock input. Requires SMBus pull-up.
2	GND	Ground Pin for the ADT7460.
3	V _{CC}	Power Supply. Can be powered by 3.3 V standby if monitoring in low power states is required. V _{CC} is also monitored through this pin. The ADT7460 can also be powered from a 5 V supply. Setting Bit 7 of Configuration Register 1 (Reg. 0x40) rescales the V _{CC} input attenuators to correctly measure a 5 V supply.
4	TACH3	Digital Input (Open Drain). Fan tachometer input to measure speed of Fan 3. Can be reconfigured as an analog input (AIN3) to measure the speed of 2-wire fans.
5	PWM2 SMBALERT	Digital Output (Open Drain). Requires 10 kΩ typical pull-up. Pulse-width modulated output to control Fan 2 speed. Digital Output (Open Drain). This pin may be reconfigured as an SMBALERT interrupt output to signal out-of-limit conditions.
6	TACH1	Digital Input (Open Drain). Fan tachometer input to measure speed of Fan 1. Can be reconfigured as an analog input (AIN1) to measure the speed of 2-wire fans.
7	TACH2	Digital Input (Open Drain). Fan tachometer input to measure speed of Fan 2. Can be reconfigured as an analog input (AIN2) to measure the speed of 2-wire fans.
8	PWM3 ADDRESS ENABLE	Digital I/O (Open Drain). Pulse-width modulated output to control Fan 3/4 speed. Requires 10 kΩ typical pull-up. If pulled low on power-up, this places the ADT7460 into address select mode, and the state of Pin 9 determines the ADT7460's slave address.
9	TACH4 ADDRESS SELECT THERM	Digital Input (Open Drain). Fan tachometer input to measure speed of Fan 4. Can be reconfigured as an analog input (AIN4) to measure the speed of 2-wire fans. If in address select mode, this pin determines the SMBus device address. Alternatively, the pin may be reconfigured as a bidirectional THERM pin. Can be used to time and monitor assertions on the THERM input. For example, can be connected to the PROCHOT output of Intel's Pentium 4 processor or to the output of a trip point temperature sensor. Can be used as an output to signal overtemperature conditions.
10	D2-	Cathode Connection to Second Thermal Diode.
11	D2+	Anode Connection to Second Thermal Diode.
12	D1-	Cathode Connection to First Thermal Diode.
13	D1+	Anode Connection to First Thermal Diode.
14	+2.5V _{IN} SMBALERT	Analog Input. Monitors 2.5 V supply, typically a chipset voltage. Digital Output (Open Drain). This pin may be reconfigured as an SMBALERT interrupt output to signal out-of-limit conditions.
15	PWM1/XTO	Digital Output (Open Drain). Pulse-width modulated output to control Fan 1 speed. Requires 10 kΩ typical pull-up.
16	SDA	Digital I/O (Open Drain). SMBus bidirectional serial data. Requires SMBus pull-up.

TYPICAL PERFORMANCE CHARACTERISTICS

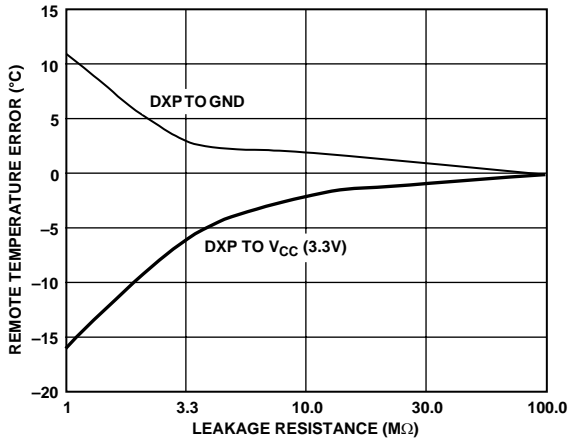

Figure 4. Remote Temperature Error vs. Leakage Resistance

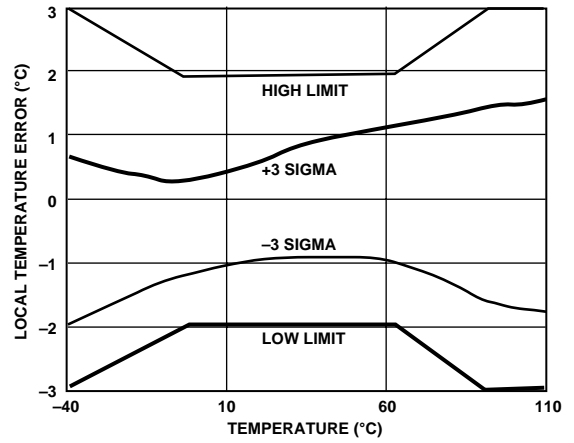

Figure 7. Local Temperature Error vs. Actual Temperature

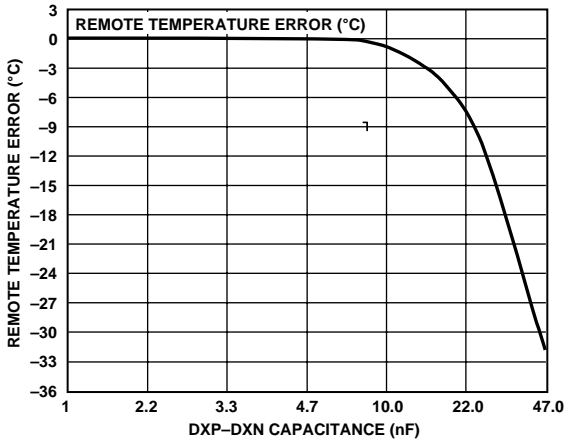

Figure 5. Remote Temperature Error vs. Capacitance between D+ and D-

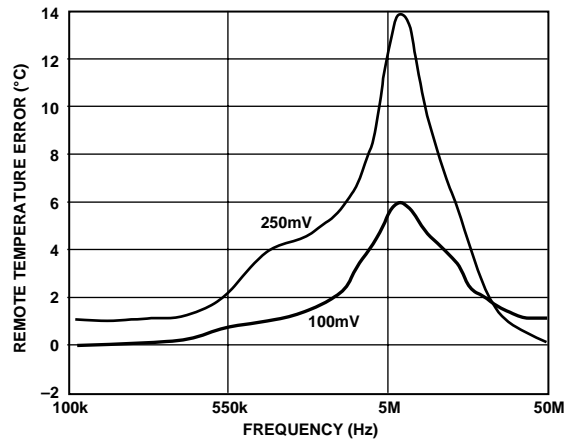

Figure 8. Remote Temperature Error vs. Power Supply Noise Frequency

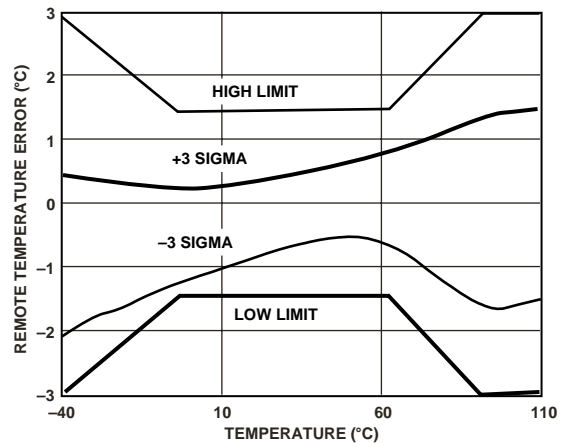

Figure 6. Remote Temperature Error vs. Actual Temperature

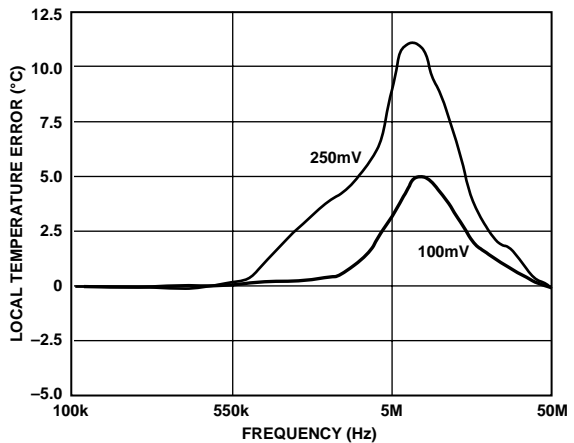

Figure 9. Local Temperature Error vs. Power Supply Noise Frequency

ADT7460

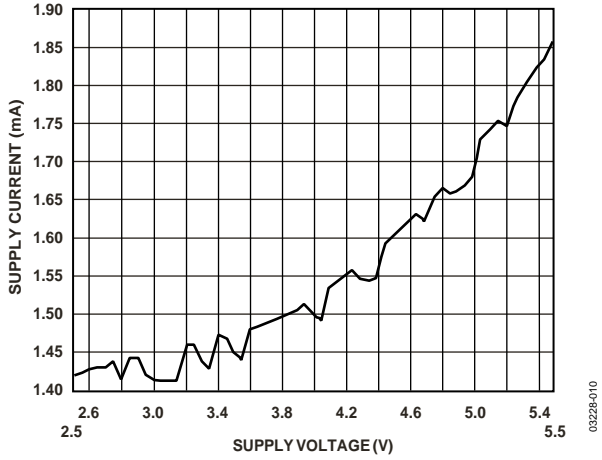

Figure 10. Supply Current vs. Supply Voltage

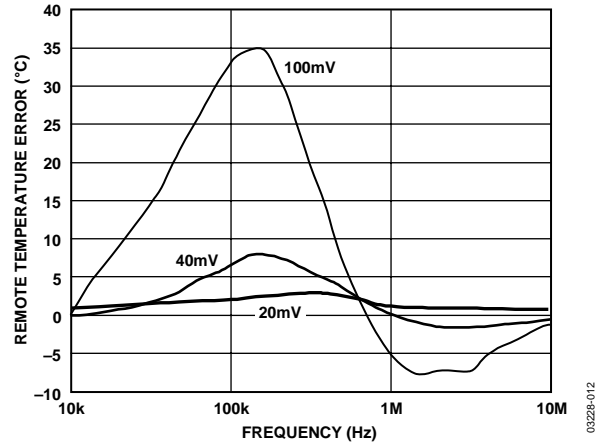

Figure 12. Remote Temperature Error vs. Common-Mode Noise Frequency

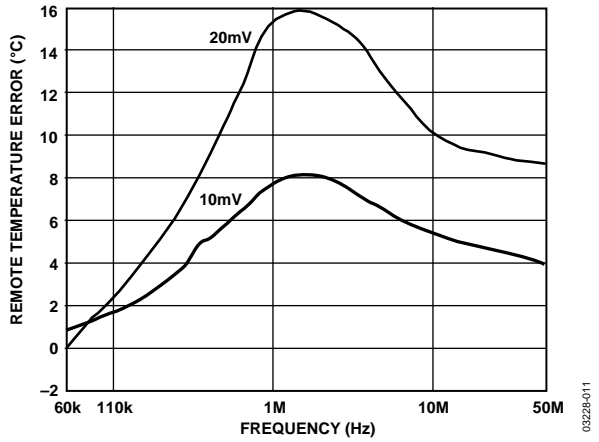

Figure 11. Remote Temperature Error vs. Differential Mode Noise Frequency

PRODUCT DESCRIPTION

The ADT7460 is a thermal monitor and multiple fan controller for any system requiring monitoring and cooling. The device communicates with the system via a serial System Management Bus (SMBus). The serial bus controller has an optional address line for device selection (Pin 9), a serial data line for reading and writing addresses and data (Pin 16), and an input line for the serial clock (Pin 1). All control and programming functions of the ADT7460 are performed over the serial bus. In addition, two of the pins can be reconfigured as an SMBALERT output to indicate out-of-limit conditions.

MEASUREMENT INPUTS

The device has three measurement inputs, one for voltage and two for temperature. It can also measure its own supply voltage and can measure ambient temperature with its on-chip temperature sensor.

Pin 14 is an analog input with an on-chip attenuator and is configured to monitor 2.5 V.

Power is supplied to the chip via Pin 3, and the system also monitors V_{CC} through this pin. In PCs, this pin is normally connected to a 3.3 V standby supply. This pin can, however, be connected to a 5 V supply and monitor it without overranging.

Remote temperature sensing is provided by the $D1\pm$ and $D2\pm$ inputs, to which diode-connected, external temperature-sensing transistors, such as a 2N3904 or CPU thermal diode, may be connected.

The ADC also accepts input from an on-chip band gap temperature sensor, which monitors system ambient temperature.

SEQUENTIAL MEASUREMENT

When the ADT7460 monitoring sequence is started, it cycles sequentially through the measurement of 2.5 V input and the temperature sensors. Measured values from these inputs are stored in value registers. These can be read out over the serial bus or can be compared with programmed limits stored in the limit registers. The results of out-of-limit comparisons are stored in the status registers, which can be read over the serial bus to flag out-of-limit conditions.

RECOMMENDED IMPLEMENTATION

Configuring the ADT7460 as in Figure 13 allows the systems designer the following features:

- Two PWM outputs for fan control of up to three fans (the front and rear chassis fans are connected in parallel).
- Three TACH fan speed measurement inputs.
- V_{CC} measured internally through Pin 3.
- CPU temperature measured using Remote 1 temperature channel.
- Ambient temperature measured through Remote 2 temperature channel.
- Bidirectional THERM pin. Allows Intel Pentium 4 PROCHOT monitoring and can function as an overtemperature THERM output.
- SMBALERT system interrupt output.

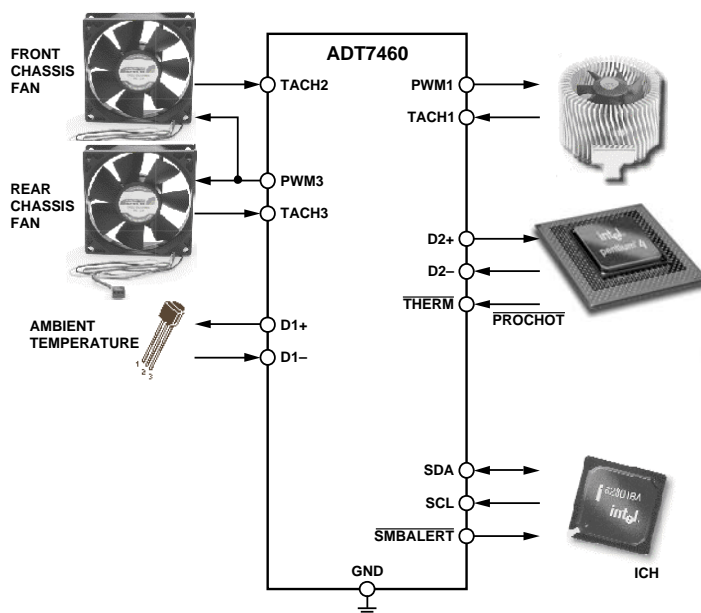

Figure 13. Recommended Implementation

ADT7460

ADT7460 ADDRESS SELECTION

Pin 8 is the dual-function PWM3/ADDRESS ENABLE pin. If Pin 8 is pulled low on power-up, the ADT7460 reads the state of Pin 9 (TACH4/ADDRESS SELECT/THERM) to determine the ADT7460's slave address. If Pin 8 is high on power-up, the ADT7460 defaults to SMBus Slave Address 0x2E. This function is described in more detail later.

INTERNAL REGISTERS OF THE ADT7460

Table 4 summarizes the ADT7460's principal internal registers. Table 41 to Table 81 describe the registers in more detail.

Table 4. Summary Internal Registers

Register	Description
Configuration	These registers provide control and configuration of the ADT7460, including alternate pinout functionality.
Address Pointer	This register contains the address that selects one of the other internal registers. When writing to the ADT7460, the first byte of data is always a register address, which is written to the address pointer register.
Status Registers	These registers provide the status of each limit comparison and are used to signal out-of-limit conditions on the temperature, voltage, or fan speed channels. If Pin 14 or Pin 5 is configured as $\overline{\text{SMBALERT}}$, this pin asserts low whenever an unmasked status bit is set.
Interrupt Mask	These registers allow each interrupt status event to be masked when Pin 14 or Pin 5 is configured as an $\overline{\text{SMBALERT}}$ output.
Value and Limit	The results of analog voltage input, temperature, and fan speed measurements are stored in these registers, along with their limit values.
Offset	These registers allow each temperature channel reading to be offset by a twos complement value written to these registers.
T_{MIN}	These registers program the starting temperature for each fan under automatic fan speed control.
T_{RANGE}	These registers program the temperature-to-fan speed control slope in automatic fan speed control mode for each PWM output.
Operating Point	These registers define the target operating temperatures for each thermal zone when running under dynamic T_{MIN} control. This function allows the cooling solution to adjust dynamically in response to measured temperature and system performance.
Enhance Acoustics	These registers allow each PWM output controlling fan to be tweaked to enhance the system's acoustics.

THEORY OF OPERATION

SERIAL BUS INTERFACE

Control of the ADT7460 is carried out using the serial System Management Bus (SMBus). The ADT7460 is connected to this bus as a slave device, under the control of a master controller.

The ADT7460 has a 7-bit serial bus address. When the device is powered up with Pin 8 (PWM3/ADDRESS ENABLE) high, the ADT7460 has a default SMBus address of 0101110 or 0x2E. If more than one ADT7460 is to be used in a system, each ADT7460 should be placed in address select mode by strapping Pin 8 low on power-up. The logic state of Pin 9 then determines the device's SMBus address. The logic state of these pins is sampled on power-up.

The device address is sampled and latched on the first valid SMBus transaction, more precisely, on the low-to-high transition at the beginning of the eighth SCL pulse, when the serial address byte matches the selected slave address. The selected slave address is chosen using the ADDRESS ENABLE /ADDRESS SELECT pins. Any attempted changes in the address has no effect after this.

Table 5. Address Select Mode

Pin 8 State	Pin 9 State	Address
0	Low (10 kΩ to GND)	0101100 (0x2C)
0	High (10 kΩ pull-up)	0101101 (0x2D)
1	Don't Care	0101110 (0x2E) (default)

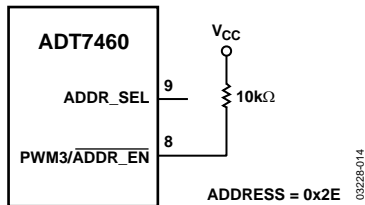

Figure 14. Default SMBus Address 0x2E

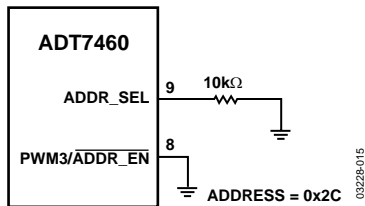

Figure 15. SMBus Address 0x2C (Pin 9 = 0)

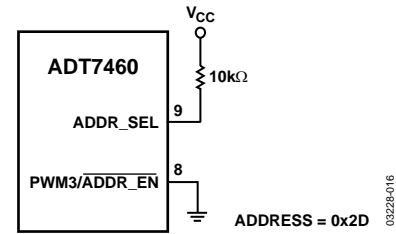
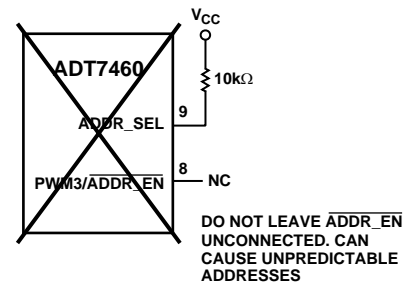

Figure 16. SMBus Address 0x2D (Pin 9 = 1)



CARE SHOULD BE TAKEN TO ENSURE THAT PIN 8 (PWM3/ADDR_EN) IS EITHER TIED HIGH OR LOW. LEAVING PIN 8 FLOATING COULD CAUSE THE ADT7460 TO POWER UP WITH AN UNEXPECTED ADDRESS. NOTE THAT IF THE ADT7460 IS PLACED INTO ADDRESS SELECT MODE, PINS 8 AND 9 CAN BE USED AS THE ALTERNATE FUNCTIONS (PWM3, TACH4/THERM) ONLY IF THE CORRECT CIRCUIT IS MUXED IN AT THE CORRECT TIME.

Figure 17. Unpredictable SMBus Address if Pin 8 is Unconnected

The facility to make hardwired changes to the SMBus slave address allows the user to avoid conflicts with other devices sharing the same serial bus, for example, if more than one ADT7460 is used in a system.

The serial bus protocol operates as follows:

1. The master initiates data transfer by establishing a start condition, defined as a high-to-low transition on the serial data line SDA while the serial clock line SCL remains high. This indicates that an address/data stream will follow. All slave peripherals connected to the serial bus respond to the start condition and shift in the next eight bits, consisting of a 7-bit address (MSB first) plus a R/W bit, which determine the direction of the data transfer, that is, whether data is written to or read from the slave device.

The peripheral whose address corresponds to the transmitted address responds by pulling the data line low during the low period before the ninth clock pulse, known as the Acknowledge bit. All other devices on the bus now remain idle while the selected device waits for data to be read from or written to it. If the R/W bit is a 0, the master writes to the slave device. If the R/W bit is a 1, the master reads from the slave device.

ADT7460

2. Data is sent over the serial bus in sequences of nine clock pulses, eight bits of data followed by an Acknowledge bit from the slave device. Transitions on the data line must occur during the low period of the clock signal and remain stable during the high period, as a low-to-high transition when the clock is high may be interpreted as a stop signal. The number of data bytes that can be transmitted over the serial bus in a single read or write operation is limited only by what the master and slave devices can handle.
3. When all data bytes have been read or written, stop conditions are established. In write mode, the master pulls the data line high during the 10th clock pulse to assert a stop condition. In read mode, the master device overrides the acknowledge bit by pulling the data line high during the low period before the ninth clock pulse. This is known as No Acknowledge. The master then takes the data line low during the low period before the 10th clock pulse, then high during the 10th clock pulse to assert a stop condition.

Any number of bytes of data may be transferred over the serial bus in one operation, but it is not possible to mix read and write in one operation because the type of operation is determined at

the beginning and cannot subsequently be changed without starting a new operation.

In the case of the ADT7460, write operations contain either one or two bytes, and read operations contain one byte.

To write data to one of the device data registers or read data from it, the address pointer register must be set so that the correct data register is addressed. Then data can be written in that register or read from it. The first byte of a write operation always contains an address that is stored in the address pointer register. If data is to be written to the device, the write operation contains a second data byte that is written to the register selected by the address pointer register.

This is illustrated in Figure 18. The device address is sent over the bus followed by R/W being set to 0. This is followed by two data bytes. The first data byte is the address of the internal data register to be written to, which is stored in the address pointer register. The second data byte is the data to be written to the internal data register.

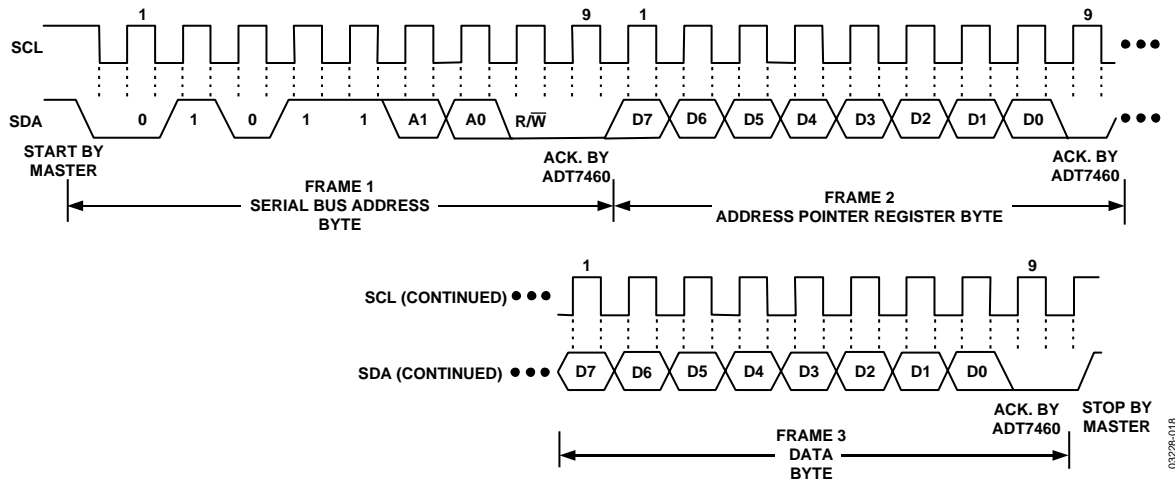

Figure 18. Writing a Register Address to the Address Pointer Register, Then Writing Data to the Selected Register

When reading data from a register, there are two possibilities:

- If the ADT7460's address pointer register value is unknown or not the desired value, it is first necessary to set it to the correct value before data can be read from the desired data register. This is done by performing a write to the ADT7460 as before, but only the data byte containing the register address is sent because data is not to be written to the register. This is shown in Figure 19.

A read operation is then performed, consisting of the serial bus address, R/\overline{W} bit set to 1, followed by the data byte read from the data register. This is shown in Figure 20.

- If the address pointer register is known to be already at the desired address, data can be read from the corresponding data register without first writing to the address pointer register, so Figure 19 can be omitted.

It is possible to *read* a data byte from a data register without first writing to the address pointer register if the address pointer register is already at the correct value. However, it is not possible to *write* data to a register without writing to the address pointer register because the first data byte of a write is always written to the address pointer register.

In Figure 18 to Figure 20, the serial bus address is shown as the default value 01011(A1)(A0), where A1 and A0 are set by the address select mode function previously defined.

In addition to supporting the Send Byte and Receive Byte protocols, the ADT7460 also supports the Read Byte protocol (see System Management Bus specifications Rev. 2.0 for more information).

If it is required to perform several read or write operations in succession, the master can send a repeat start condition instead of a stop condition to begin a new operation.

Write Operations

The SMBus specification defines several protocols for different types of read and write operations. The ones used in the ADT7460 are discussed below. The following abbreviations are used in the diagrams:

- S—start
- P—stop
- R—read
- W—write
- \underline{A} —acknowledge
- \overline{A} —no acknowledge

The ADT7460 uses the following SMBus write protocols:

Send Byte

In this operation, the master device sends a single command byte to a slave device as follows:

1. The master device asserts a start condition on SDA.
2. The master sends the 7-bit slave address followed by the write bit (low).
3. The addressed slave device asserts ACK on SDA.
4. The master sends the register address.
5. The slave asserts ACK on SDA.
6. The master asserts a stop condition on SDA and the transaction ends.

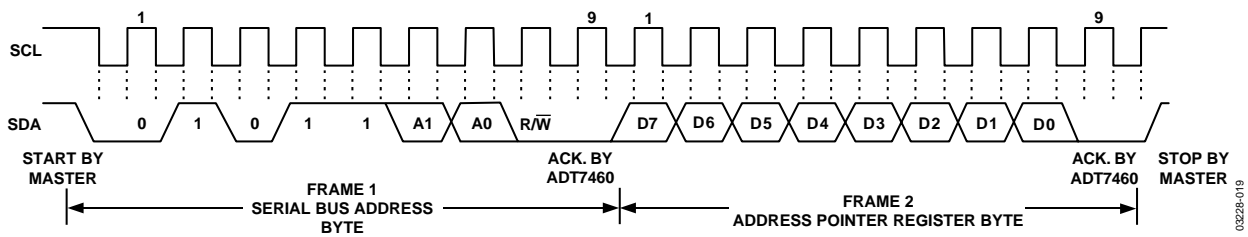

Figure 19. Writing to the Address Pointer Register Only

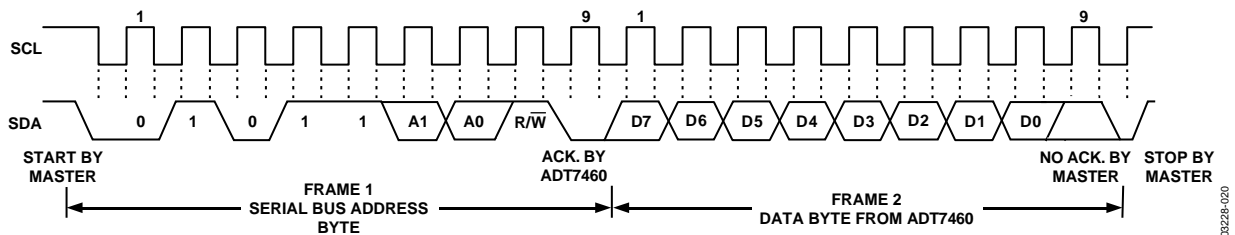

Figure 20. Reading Data from a Previously Selected Register

ADT7460

For the ADT7460, the send byte protocol is used to write to the address pointer register for a subsequent single-byte read from the same address. This is illustrated in Figure 21.

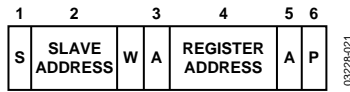

Figure 21. Setting a Register Address for Subsequent Read

If it is required to read data from the register immediately after setting up the address, the master can assert a repeat start condition immediately after the final ACK and carry out a single-byte read without asserting an intermediate stop condition.

Write Byte

In this operation, the master device sends a command byte and one data byte to the slave device as follows:

1. The master device asserts a start condition on SDA.
2. The master sends the 7-bit slave address followed by the write bit (low).
3. The addressed slave device asserts ACK on SDA.
4. The master sends the register address.
5. The slave asserts ACK on SDA.
6. The master sends a data byte.
7. The slave asserts ACK on SDA.
8. The master asserts a stop condition on SDA to end the transaction.

This is illustrated in Figure 22.

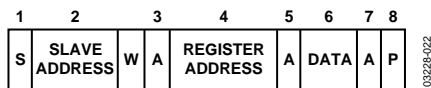

Figure 22. Single-Byte Write to a Register

Read Operations

The ADT7460 uses the following SMBus read protocols.

Receive Byte

This is useful when repeatedly reading a single register. The register address needs to have been set up previously. In this operation, the master device receives a single byte from a slave device as follows:

1. The master device asserts a start condition on SDA.
2. The master sends the 7-bit slave address followed by the read bit (high).

3. The addressed slave device asserts ACK on SDA.
4. The master receives a data byte.
5. The master asserts NO ACK on SDA.
6. The master asserts a stop condition on SDA and the transaction ends.

In the ADT7460, the receive byte protocol is used to read a single byte of data from a register whose address has previously been set by a send byte or by write byte operation.

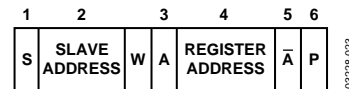

Figure 23. Single-Byte Read from a Register

Alert Response Address

Alert response address (ARA) is a feature of SMBus devices that allows an interrupting device to identify itself to the host when multiple devices exist on the same bus.

The $\overline{\text{SMBALERT}}$ output can be used as an interrupt output or can be used as an $\overline{\text{SMBALERT}}$. One or more outputs can be connected to a common $\overline{\text{SMBALERT}}$ line connected to the master. If a device's $\overline{\text{SMBALERT}}$ line goes low, the following occurs:

1. $\overline{\text{SMBALERT}}$ is pulled low.
2. Master initiates a read operation and sends the alert response address (ARA = 0001 100). This is a general call address, which must not be used as a specific device address.
3. The device whose $\overline{\text{SMBALERT}}$ output is low responds to the alert response address, and the master reads its device address. The address of the device is now known, and it can be interrogated in the usual way.
4. If more than one device's $\overline{\text{SMBALERT}}$ output is low, the one with the lowest device address has priority in accordance with normal SMBus arbitration.
5. Once the ADT7460 has responded to the alert response address, the master must read the status registers and the $\overline{\text{SMBALERT}}$ is cleared only if the error condition has gone away.

SMBus Timeout

The ADT7460 includes an SMBus timeout feature. If there is no SMBus activity for 25 ms, the ADT7460 assumes that the bus is locked and releases the bus. This prevents the device from locking or holding the SMBus expecting data. Some SMBus controllers cannot handle the SMBus timeout feature, so it can be disabled.

Table 6. Configuration Register 1 (Reg. 0x40)

Bit	Description
<6> TODIS	0: SMBus timeout enabled (default)
<6> TODIS	1: SMBus timeout disabled

VOLTAGE MEASUREMENT INPUT

The ADT7460 has one external voltage measurement channel. It can also measure its own supply voltage, V_{CC} .

Pin 14 may be configured to measure a 2.5 V supply. The V_{CC} supply voltage measurement is carried out through the V_{CC} pin (Pin 3). Setting Bit 7 of Configuration Register 1 (Reg. 0x40) allows a 5 V supply to power the ADT7460 and be measured without overranging the V_{CC} measurement channel. The 2.5 V input can be used to monitor a chipset supply voltage in computer systems.

Analog-to-Digital Converter

All analog inputs are multiplexed into the on-chip, successive approximation, analog-to-digital converter. This has a resolution of 10 bits. The basic input range is 0 V to 2.25 V, but the input has built-in attenuators to allow measurement of 2.5 V without any external components. To allow the tolerance of the supply voltage, the ADC produces an output of 3/4 full scale (768d or 0x300) for the nominal input voltage and so has adequate headroom to deal with overvoltages.

Input Circuitry

The internal structure for the 2.5 V analog input is shown in Figure 24. The input circuit consists of an input protection diode, an attenuator, plus a capacitor to form a first-order low-pass filter that gives the input immunity to high frequency noise.

Table 7. Voltage Measurement Registers

Register	Description	Default
0x20	2.5 V reading	0x00
0x22	V_{CC} reading	0x00

Associated with the voltage measurement channels are a high and low limit register. Exceeding the programmed high or low limit causes the appropriate status bit to be set. Exceeding either limit can also generate SMBALERT interrupts.

Table 8. 2.5 V Limit Registers

Register	Description	Default
0x44	2.5 V low limit	0x00
0x45	2.5 V high limit	0xFF
0x48	V_{CC} low limit	0x00
0x49	V_{CC} high limit	0xFF

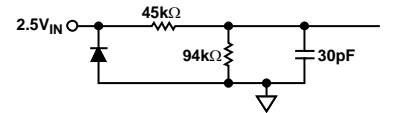

Figure 24. Structure of Analog Inputs

Table 9 shows the input ranges of the analog inputs and output codes of the 10-bit ADC.

When the ADC is running, it samples and converts a voltage input in 711 μ s and averages 16 conversions to reduce noise; a measurement takes nominally 11.38 ms.

ADT7460

Table 9. 10-Bit A/D Output Code vs. V_{IN}

Input Voltage			A/D Output	
$5 V_{IN}$	$V_{CC} (3.3 V_{IN})^1$	$2.5 V_{IN}$	Decimal	Binary (10 Bits)
<0.0065	<0.0042	<0.0032	0	00000000 00
0.0065–0.0130	0.0042–0.0085	0.0032–0.0065	1	00000000 01
0.0130–0.0195	0.0085–0.0128	0.0065–0.0097	2	00000000 10
0.0195–0.0260	0.0128–0.0171	0.0097–0.0130	3	00000000 11
0.0260–0.0325	0.0171–0.0214	0.0130–0.0162	4	00000001 00
0.0325–0.0390	0.0214–0.0257	0.0162–0.0195	5	00000001 01
0.0390–0.0455	0.0257–0.0300	0.0195–0.0227	6	00000001 10
0.0455–0.0521	0.0300–0.0343	0.0227–0.0260	7	00000001 11
0.0521–0.0586	0.0343–0.0386	0.0260–0.0292	8	00000010 00
.
.
.
1.6675–1.6740	1.1000–1.1042	0.8325–0.8357	256 (1/4 scale)	01000000 00
.
.
.
3.3300–3.3415	2.2000–2.2042	1.6650–1.6682	512 (1/2 scale)	10000000 00
.
.
.
5.0025–5.0090	3.3000–3.3042	2.4975–2.5007	768 (3/4 scale)	11000000 00
.
.
.
6.5983–6.6048	4.3527–4.3570	3.2942–3.2974	1013	11111101 01
6.6048–6.6113	4.3570–4.3613	3.2974–3.3007	1014	11111101 10
6.6113–6.6178	4.3613–4.3656	3.3007–3.3039	1015	11111101 11
6.6178–6.6244	4.3656–4.3699	3.3039–3.3072	1016	11111110 00
6.6244–6.6309	4.3699–4.3742	3.3072–3.3104	1017	11111110 01
6.6309–6.6374	4.3742–4.3785	3.3104–3.3137	1018	11111110 10
6.6374–6.4390	4.3785–4.3828	3.3137–3.3169	1019	11111110 11
6.6439–6.6504	4.3828–4.3871	3.3169–3.3202	1020	11111111 00
6.6504–6.6569	4.3871–4.3914	3.3202–3.3234	1021	11111111 01
6.6569–6.6634	4.3914–4.3957	3.3234–3.3267	1022	11111111 10
>6.6634	>4.3957	>3.3267	1023	11111111 11

¹ The V_{CC} output codes listed assume that V_{CC} is 3.3 V. If V_{CC} input is reconfigured for 5 V operation (by setting Bit 7 of Configuration Register 1), the V_{CC} output codes are the same as for the $5 V_{IN}$ column.

ADDITIONAL ADC FUNCTIONS FOR VOLTAGE MEASUREMENTS

A number of other functions are available on the ADT7460 to offer the systems designer increased flexibility.

Turn-Off Averaging

For each voltage measurement read from a value register, 16 readings have actually been made internally and the results averaged before being placed into the value register. If the user wants to speed up conversion, setting Bit 4 of Configuration Register 2 (Reg. 0x73) turns averaging off. This effectively gives a reading 16 times faster (711 μs), but the reading may be noisier.

Bypass Voltage Input Attenuator

Setting Bit 5 of Configuration Register 2 (Reg. 0x73) removes the attenuation circuitry from the 2.5 V input. This allows the user to directly connect external sensors or to rescale the analog voltage measurement inputs for other applications. The input range of the ADC without the attenuators is 0 V to 2.25 V.

Single-Channel ADC Conversion

Setting Bit 6 of Configuration Register 2 (Reg. 0x73) places the ADT7460 into single-channel ADC conversion mode. In this mode, the ADT7460 can be made to read a single voltage channel only. If the internal ADT7460 clock is used, the selected input is read every 711 μs. The appropriate ADC channel is selected by writing to Bits <7:5> of the TACH1 Minimum High Byte register (Reg. 0x55).

Table 10. Configuration Register 2 (Reg. 0x73)

Bit	Description
<4>	1: averaging off
<5>	1: bypass input attenuators
<6>	1: single-channel convert mode

Table 11. TACH1 Minimum High Byte (Reg. 0x55)

Bit	Description
<7:5>	Selects ADC channel for single-channel convert mode
Value	Channel Selected
000	2.5 V
010	V _{CC}

TEMPERATURE MEASUREMENT SYSTEM

Local Temperature Measurement

The ADT7460 contains an on-chip band gap temperature sensor whose output is digitized by the on-chip 10-bit ADC. The 8-bit MSB temperature data is stored in the local temperature register (Address 0x26). As both positive and negative temperatures can be measured, the temperature data is stored in twos complement format, as shown in Table 12. Theoretically, the temperature sensor and ADC can measure temperatures from -128°C to +127°C with a resolution of 0.25°C. However, this exceeds the operating temperature range of the device, so local temperature measurements outside this range are not possible.

Remote Temperature Measurement

The ADT7460 can measure the temperature of two remote diode sensors or diode-connected transistors connected to Pins 12 and 13, or Pins 10 and 11.

The forward voltage of a diode or diode-connected transistor operated at a constant current exhibits a negative temperature coefficient of about -2 mV/°C. Unfortunately, the absolute value of V_{BE} varies from device to device, and individual calibration is required to null this out, so the technique is unsuitable for mass production. The technique used in the ADT7460 is to measure the change in V_{BE} when the device is operated at two different currents. This is given by

$$\Delta V_{BE} = \frac{KT}{q} \times \ln(N)$$

where:

- K is Boltzmann's constant.
- q is the charge on the carrier.
- T is the absolute temperature in Kelvins.
- N is the ratio of the two currents.

Figure 25 shows the input signal conditioning used to measure the output of a remote temperature sensor. This figure shows the external sensor as a substrate transistor provided for temperature monitoring on some microprocessors. It could equally well be a discrete transistor, such as a 2N3904.

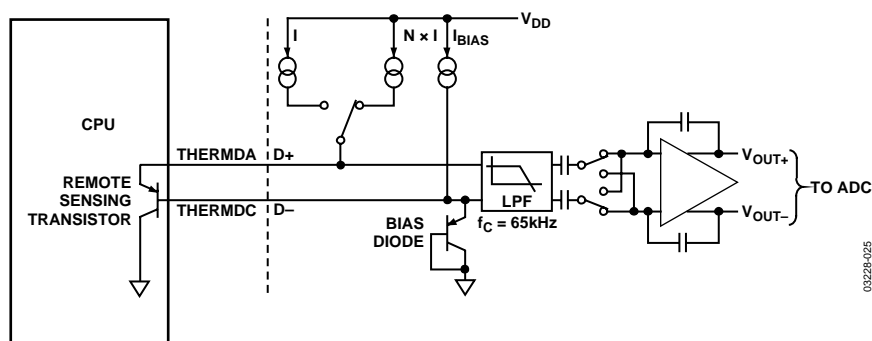

Figure 25. Signal Conditioning for Remote Diode Temperature Sensors

ADT7460

If a discrete transistor is used, the collector is not grounded, and it should be linked to the base. If a PNP transistor is used, the base is connected to the D– input and the emitter to the D+ input. If an NPN transistor is used, the emitter is connected to the D– input, and the base to the D+ input. Figure 26 and Figure 27 show how to connect the ADT7460 to an NPN or PNP transistor for temperature measurement. To prevent ground noise from interfering with the measurement, the more negative terminal of the sensor is not referenced to ground but is biased above ground by an internal diode at the D– input.

To measure ΔV_{BE} , the sensor is switched between operating currents of I and $N \times I$. The resulting waveform is passed through a 65 kHz low-pass filter to remove noise and to a chopper stabilized amplifier that performs the functions of amplification and rectification of the waveform to produce a dc voltage proportional to ΔV_{BE} . This voltage is measured by the ADC to give a temperature output in 10-bit, twos complement format. To further reduce the effects of noise, digital filtering is performed by averaging the results of 16 measurement cycles. A remote temperature measurement takes nominally 25.5 ms. The results of remote temperature measurements are stored in 10-bit, twos complement format, as illustrated in Table 12. The extra resolution for the temperature measurements is held in the Extended Resolution Register 2 (Reg. 0x77). This gives temperature readings with a resolution of 0.25°C.

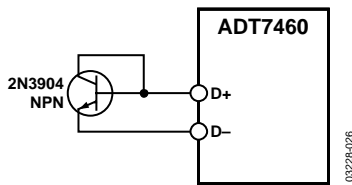

Figure 26. Measuring Temperature by Using an NPN Transistor

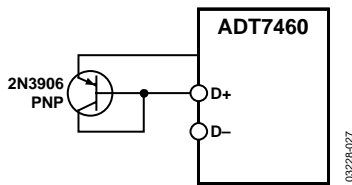

Figure 27. Measuring Temperature by Using a PNP Transistor

Table 12. Temperature Data Format

Temperature	Digital Output (10-Bit) ¹
-128°C	1000 0000 00
-125°C	1000 0011 00
-100°C	1001 1100 00
-75°C	1011 0101 00
-50°C	1100 1110 00
-25°C	1110 0111 00
-10°C	1111 0110 00
0°C	0000 0000 00
+10.25°C	0000 1010 01
+25.5°C	0001 1001 10
+50.75°C	0011 0010 11
+75°C	0100 1011 00
+100°C	0110 0100 00
+125°C	0111 1101 00
+127°C	0111 1111 00

¹ Bold denotes 2 LSBs of measurement in the Extended Resolution Register 2 (Reg. 0x77) with 0.25°C resolution.

Table 13. Temperature Measurement Registers

Register	Description	Default
0x25	Remote 1 temperature	0x80
0x26	Local temperature	0x80
0x27	Remote 2 temperature	0x80
0x77	Extended Resolution 2	0x00

Table 14. Extended Resolution Temperature Measurement Register Bits (Addr = 0x77)

Bit	Mnemonic	Description
<7:6>	TDM2	Remote 2 temperature LSBs
<5:4>	LTMP	Local temperature LSBs
<3:2>	TDM1	Remote 1 temperature LSBs

Reading Temperature from the ADT7460

It is important to note that temperature can be read from the ADT7460 as an 8-bit value (with 1°C resolution) or as a 10-bit value (with 0.25 C resolution). If only 1°C resolution is required, the temperature readings can be read back at any time and in no particular order.

If the 10-bit measurement is required, this involves a 2-register read for each measurement. The extended resolution register (Reg. 0x77) should be read first. This causes all temperature reading registers to be frozen until all temperature reading registers have been read from. This prevents an MSB reading from being updated while its two LSBs are being read, and vice versa.

Nulling Out Temperature Errors

As CPUs run faster, it becomes more difficult to avoid high frequency clocks when routing the D+, D- traces around a system board. Even when recommended layout guidelines are followed, there may still be temperature errors attributed to noise being coupled onto the D+/D- lines. High frequency noise generally has the effect of giving temperature measurements that are too high by a constant amount. The ADT7460 has temperature offset registers at Addresses 0x70, 0x72 for the Remote 1 and Remote 2 temperature channels. By doing a one-time calibration of the system, one can determine the offset caused by system board noise and null it out using the offset registers. The offset registers automatically add a twos complement 8-bit reading to every temperature measurement. The LSB adds 0.25°C offset to the temperature reading so the 8-bit register effectively allows temperature offsets of up to ±32°C with a resolution of 0.25°C. This ensures that the readings in the temperature measurement registers are as accurate as possible.

Table 15. Temperature Offset Registers

Register	Description	Default
0x70	Remote 1 temperature offset	0x00 (0°C)
0x71	Local temperature offset	0x00 (0°C)
0x72	Remote 2 temperature offset	0x00 (0°C)

Temperature Measurement Limit Registers

Associated with each temperature measurement channel are high and low limit registers. Exceeding the programmed high or low limit causes the appropriate status bit to be set. Exceeding either limit can also generate SMBALERT interrupts.

Table 16. Temperature Measurement Limit Registers

Register	Description	Default
0x4E	Remote 1 temperature low limit	0x81
0x4F	Remote 1 temperature high limit	0x7F
0x50	Local temperature low limit	0x81
0x51	Local temperature high limit	0x7F
0x52	Remote 2 temperature low limit	0x81
0x53	Remote 2 temperature high limit	0x7F

Overtemperature Events

Overtemperature events on any of the temperature channels can be detected and dealt with automatically in automatic fan speed control mode. Registers 0x6A to 0x6C are the THERM limits. When a temperature exceeds its THERM limit, all fans run at 100% duty cycle. The fans continue running at 100% until the temperature drops below THERM - Hysteresis. (This can be disabled by setting the BOOST bit in Configuration Register 3, Bit 2, Register 0x78). The hysteresis value for that THERM limit is the value programmed into Registers 0x6D and 0x6E (hysteresis registers). The default hysteresis value is 4°C.

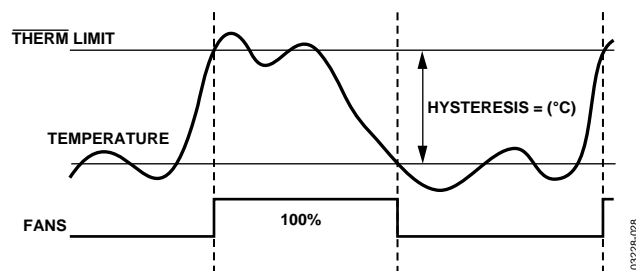

Figure 28. THERM Limit Operation

ADDITIONAL ADC FUNCTIONS FOR TEMPERATURE MEASUREMENT

A number of other functions are available on the ADT7460 to offer the systems designer increased flexibility:

Turn-Off Averaging

For each temperature measurement read from a value register, 16 readings have actually been made internally and the results averaged before being placed into the value register. Sometimes it may be necessary to take a very fast measurement, for example, of CPU temperature. Setting Bit 4 of Configuration Register 2 (Reg. 0x73) turns averaging off. This takes a reading every 15.5 ms. Each remote temperature measurement takes 4 ms and the local temperature measurement takes 1.4 ms.

Single-Channel ADC Conversions

Setting Bit 6 of Configuration Register 2 (Reg. 0x73) places the ADT7460 into single-channel ADC conversion mode. In this mode, the ADT7460 can be made to read a single temperature channel only. The appropriate ADC channel is selected by writing to Bits <7:5> of the TACH1 minimum high byte register (Reg. 0x55).

Table 17. Configuration Register 2 (Reg. 0x73)

Bit	Description
<4>	1: Averaging off
<6>	1: single-channel convert mode

Table 18. TACH1 Minimum High Byte (Reg. 0x55)

Bit	Description
<7:5>	Selects ADC channel for single-channel convert mode
Value	Channel Selected
101	Remote 1 temp
110	Local temp
111	Remote 2 temp

LIMITS, STATUS REGISTERS, AND INTERRUPTS

Limit Values

Associated with each measurement channel on the ADT7460 are high and low limits. These can form the basis of system status monitoring: a status bit can be set for any out-of-limit condition and detected by polling the device. Alternatively, SMBALERT interrupts can be generated to flag a processor or microcontroller of out-of-limit conditions.

8-Bit Limits

The following is a list of 8-bit limits on the ADT7460.

Table 19. Voltage Limit Registers

Register	Description	Default
0x44	2.5 V low limit	0x00
0x45	2.5 V high limit	0xFF
0x48	V _{CC} low limit	0x00
0x49	V _{CC} high limit	0xFF

Table 20. Temperature Limit Registers

Register	Description	Default
0x4E	Remote 1 temperature low limit	0x81
0x4F	Remote 1 temperature high limit	0x7F
0x6A	Remote 1 THERM limit	0x64
0x50	Local temperature low limit	0x81
0x51	Local temperature high limit	0x7F
0x6B	Local THERM limit	0x64
0x52	Remote 2 temperature low limit	0x81
0x53	Remote 2 temperature high limit	0x7F
0x6C	Remote 2 THERM limit	0x64

Table 21. THERM Timer Limit Register

Register	Description	Default
0x7A	THERM timer limit	0x00

16-Bit Limits

The fan TACH measurements are 16-bit results. The fan TACH limits are also 16 bits, consisting of a high byte and low byte. Since fans running under speed or stalled are normally the only conditions of interest, only high limits exist for fan TACHs. Since fan TACH period is actually being measured, exceeding the limit indicates a slow or stalled fan.

Table 22. Fan Limit Registers

Register	Description	Default
0x54	TACH1 minimum low byte	0xFF
0x55	TACH1 minimum high byte	0xFF
0x56	TACH2 minimum low byte	0xFF
0x57	TACH2 minimum high byte	0xFF
0x58	TACH3 minimum low byte	0xFF
0x59	TACH3 minimum high byte	0xFF
0x5A	TACH4 minimum low byte	0xFF
0x5B	TACH4 minimum high byte	0xFF

Out-of-Limit Comparisons

Once all limits have been programmed, the ADT7460 can be enabled for monitoring. The ADT7460 measures all parameters in round-robin format and sets the appropriate status bit for out-of-limit conditions. Comparisons are done differently depending on whether the measured value is being compared to a high or low limit.

- High limit: > comparison performed
- Low limit: < or = comparison performed

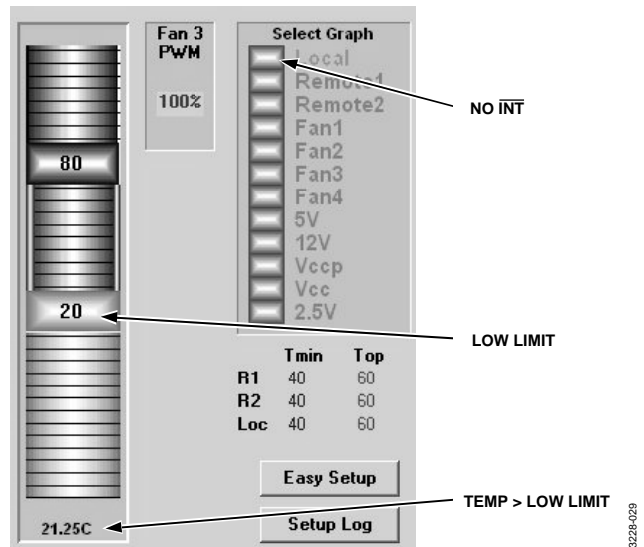

Figure 29. Temperature > Low Limit: No \overline{INT}

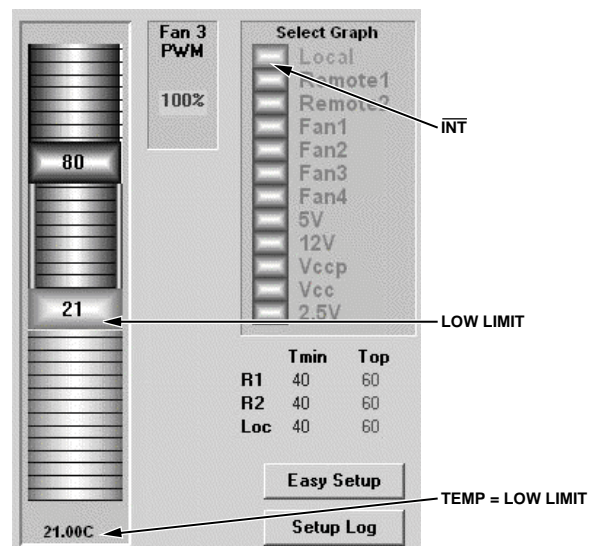

Figure 30. Temperature = Low Limit: \overline{INT} Occurs

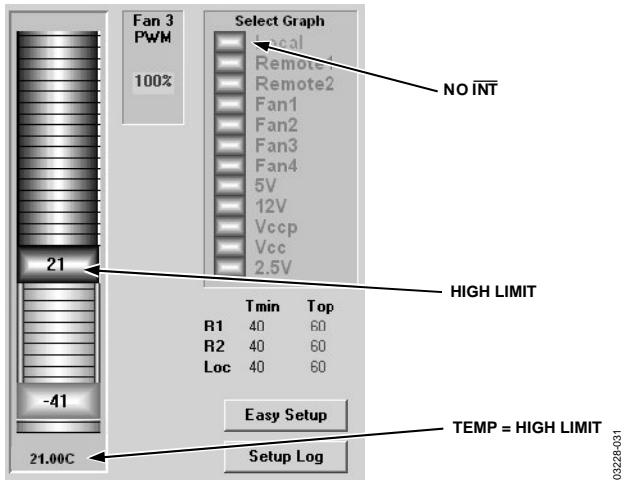

Figure 31. Temperature = High Limit: No \overline{INT}

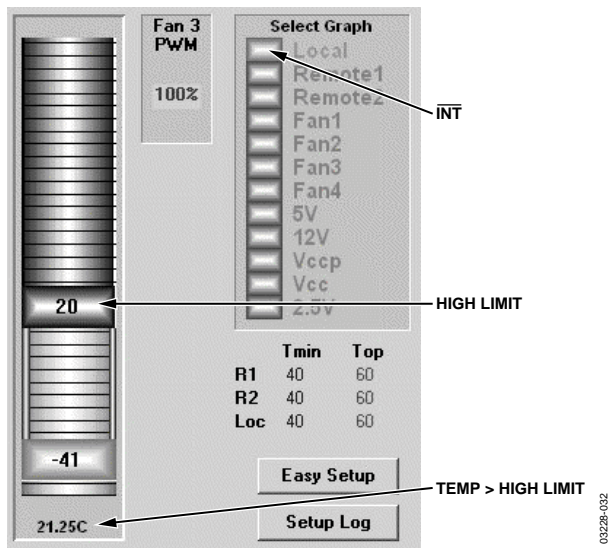

Figure 32. Temperature > High Limit: \overline{INT} Occurs

Analog Monitoring Cycle Time

The analog monitoring cycle begins when a 1 is written to the start bit (Bit 0) of Configuration Register 1 (Reg. 0x40). The ADC measures each analog input in turn and, as each measurement is completed, the result is automatically stored in the appropriate value register. This round-robin monitoring cycle continues unless disabled by writing a 0 to Bit 0 of Configuration Register 1.

As the ADC is normally allowed to free-run in this manner, the time taken to monitor all the analog inputs is normally not of interest, since the most recently measured value of any input can be read out at any time. For applications where the monitoring cycle time is important, it can easily be calculated.

The total number of channels measured is

- Two supply voltage inputs (2.5 V and V_{CC})
- Local temperature
- Two remote temperatures

As mentioned previously, the ADC performs round-robin conversions and takes 11.38 ms for each voltage measurement, 12 ms for a local temperature reading, and 25.5 ms for each remote temperature reading.

The total monitoring cycle time for averaged voltage and temperature monitoring is, therefore, nominally

$$(2 \times 11.38) + 12 (2 \times 25.5) = 85.76 \text{ ms}$$

The round robin starts again 35 ms later. Therefore, all channels are measured approximately every 120 ms.

Fan TACH measurements are made in parallel and are not synchronized with the analog measurements in any way.

STATUS REGISTERS

The results of limit comparisons are stored in Status Registers 1 and 2. The status register bit for each channel reflects the status of the last measurement and limit comparison on that channel. If a measurement is within limits, the corresponding status register bit is cleared to 0. If the measurement is out-of-limits, the corresponding status register bit is set to 1.

The state of the various measurement channels may be polled by reading the status registers over the serial bus. In Bit 7 (OOL) of Status Register 1 (Reg. 0x41), 1 means that an out-of-limit event has been flagged in Status Register 2. This means that you need only read Status Register 2 when this bit is set. Alternatively, Pin 5 or Pin 14 can be configured as an SMBALERT output. This automatically notifies the system supervisor of an out-of-limit condition. Reading the status registers clears the appropriate status bit as long as the error condition that caused the interrupt has cleared. Status register bits are “sticky.” Whenever a status bit is set, indicating an out-of-limit condition, it remains set even if the event that caused it has gone away (until read). The only way to clear the status bit is to read the status register after the event has gone away. Interrupt status mask registers (Reg. 0x74, 0x75) allow individual interrupt sources to be masked from causing an SMBALERT. However, if one of these masked interrupt sources goes out-of-limit, its associated status bit is set in the interrupt status registers.

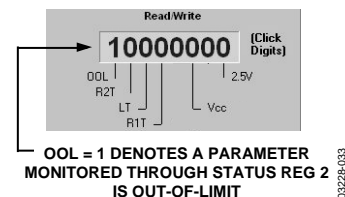

Figure 33. Status Register 1

Table 23. Status Register 1 (Reg. 0x41)

Bit	Mnemonic	Description
7	OOL	1 denotes a bit in Status Register 2 is set and Status Register 2 should be read.
6	R2T	1 indicates that the Remote 2 temperature high or low limit has been exceeded.
5	LT	1 indicates that the Local temperature high or low limit has been exceeded.
4	R1T	1 indicates that the Remote 1 temperature high or low limit has been exceeded.
3	-	Unused
2	VCC	1 indicates that the VCC high or low limit has been exceeded.
1	-	Unused
0	2.5 V	1 indicates that the 2.5 V high or low limit has been exceeded.

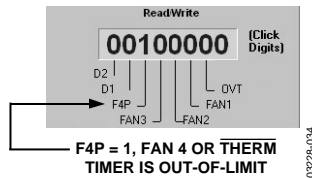

Figure 34. Status Register 2

Table 24. Status Register 2 (Reg. 0x42)

Bit	Mnemonic	Description
7	D2	1 indicates an open or short on D2+/D2- inputs.
6	D1	1 indicates an open or short on D1+/D1- inputs.
5	F4P	1 indicates that Fan 4 has dropped below minimum speed. Alternatively, indicates that THERM timer limit has been exceeded if the THERM timer function is used.
4	FAN3	1 indicates that Fan 3 has dropped below minimum speed.
3	FAN2	1 indicates that Fan 2 has dropped below minimum speed.
2	FAN1	1 indicates that Fan 1 has dropped below minimum speed.
1	OVT	1 indicates that a THERM overtemperature limit has been exceeded.
0	-	Unused

SMBALERT Interrupt Behavior

The ADT7460 can be polled for status, or an SMBALERT interrupt can be generated for out-of-limit conditions. It is important to note how the SMBALERT output and status bits behave when writing interrupt handler software.

Figure 35 shows how the SMBALERT output and sticky status bits behave. Once a limit is exceeded, the corresponding status bit is set to 1. The status bit remains set until the error condition subsides and the status register is read. The status bits are referred to as sticky since they remain set until read by software. This ensures that an out-of-limit event cannot be missed if software is polling the device periodically. Note that the SMBALERT output remains low for the entire duration that a reading is out-of-limit and until the status register has been read. This has implications on how software handles the interrupt.

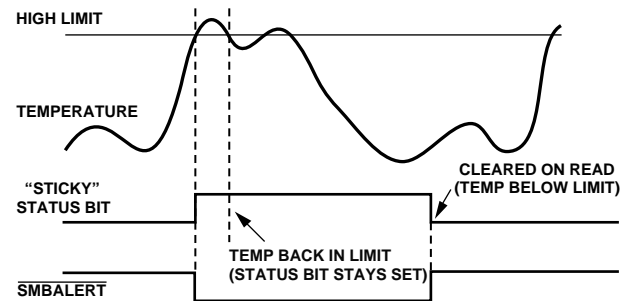

Figure 35. SMBALERT and Status Bit Behavior

HANDLING SMBALERT INTERRUPTS

To prevent the system from being tied up servicing interrupts, it is recommended to handle the SMBALERT interrupt as follows:

1. Detect the SMBALERT assertion.
2. Enter the interrupt handler.
3. Read the status registers to identify the interrupt source.
4. Mask the interrupt source by setting the appropriate mask bit in the interrupt mask registers (Reg. 0x74, 0x75).
5. Take the appropriate action for a given interrupt source.
6. Exit the interrupt handler.
7. Periodically poll the status registers. If the interrupt status bit has cleared, reset the corresponding interrupt mask bit to 0. This causes the SMBALERT output and status bits to behave as shown in Figure 36.

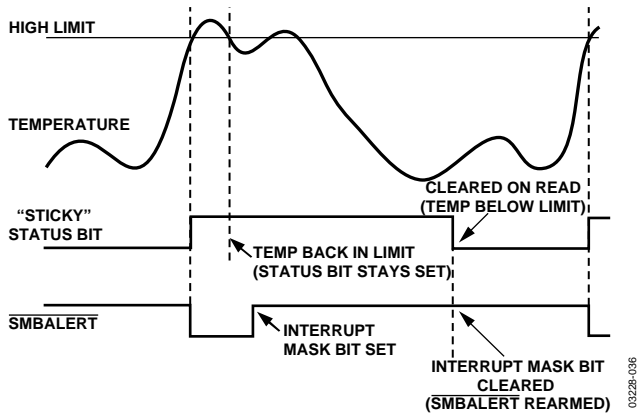

Figure 36. How Masking the Interrupt Source Affects $\overline{\text{SMBALERT}}$ Output

Masking Interrupt Sources

Interrupt Mask Registers 1 and 2 are located at Addresses 0x74 and 0x75. These allow individual interrupt sources to be masked out to prevent $\overline{\text{SMBALERT}}$ interrupts. Note that masking an interrupt source prevents only the $\overline{\text{SMBALERT}}$ output from being asserted; the appropriate status bit is set as normal.

Table 25. Interrupt Mask Register 1 (Reg. 0x74)

Bit	Mnemonic	Description
7	OOL	1 masks $\overline{\text{SMBALERT}}$ for any alert condition flagged in Status Register 2.
6	R2T	1 masks $\overline{\text{SMBALERT}}$ for Remote 2 temperature.
5	LT	1 masks $\overline{\text{SMBALERT}}$ for local temperature.
4	R1T	1 masks $\overline{\text{SMBALERT}}$ for Remote 1 temperature.
3	-	Unused
2	VCC	1 masks $\overline{\text{SMBALERT}}$ for the VCC channel.
1	-	Unused
0	2.5 V	1 masks $\overline{\text{SMBALERT}}$ for the 2.5 V channel.

Table 26. Interrupt Mask Register 2 (Reg. 0x75)

Bit	Mnemonic	Description
7	D2	1 masks $\overline{\text{SMBALERT}}$ for Diode 2 errors.
6	D1	1 masks $\overline{\text{SMBALERT}}$ for Diode 1 errors.
5	FAN4	1 masks $\overline{\text{SMBALERT}}$ for Fan 4 failure. If the TACH4 pin is being used as the $\overline{\text{THERM}}$ input, this bit masks $\overline{\text{SMBALERT}}$ for a $\overline{\text{THERM}}$ event.
4	FAN3	1 masks $\overline{\text{SMBALERT}}$ for Fan 3.
3	FAN2	1 masks $\overline{\text{SMBALERT}}$ for Fan 2.
2	FAN1	1 masks $\overline{\text{SMBALERT}}$ for Fan 1.
1	OVT	1 masks $\overline{\text{SMBALERT}}$ for overtemperature (exceeding $\overline{\text{THERM}}$ limits).
0	-	Unused

Enabling the $\overline{\text{SMBALERT}}$ Interrupt Output

The $\overline{\text{SMBALERT}}$ interrupt function is disabled by default. Pin 5 or Pin 14 can be reconfigured as an $\overline{\text{SMBALERT}}$ output to signal out-of-limit conditions.

Table 27. Config Register 4 (Reg. 0x7D)

Pin No.	Bit Setting
14	<0> AL2.5V = 1

Table 28. Config Register 3 (Reg. 0x78)

Pin No.	Bit Setting
5	<0> ALERT = 1

To Assign $\overline{\text{THERM}}$ Functionality to Pin 9

Pin 9 can be configured as the $\overline{\text{THERM}}$ pin on the ADT7460. To configure Pin 9 as the $\overline{\text{THERM}}$ pin, set the $\overline{\text{THERM}}$ ENABLE Bit (Bit 1) in Configuration Register 3 (Address 0x78) = 1.

$\overline{\text{THERM}}$ as an Input

When configured as an input, the $\overline{\text{THERM}}$ pin allows the user to time assertions on the pin. This can be useful for connecting to the $\overline{\text{PROCHOT}}$ output of a CPU to gauge system performance. For more information on timing $\overline{\text{THERM}}$ assertions and generating $\overline{\text{SMBALERT}}$ s based on $\overline{\text{THERM}}$, see the Generating Interrupts from Events section.

The user can also set up the ADT7460 so when the $\overline{\text{THERM}}$ pin is driven low externally, the fans run at 100%. The fans run at 100% while the $\overline{\text{THERM}}$ pin is pulled low.

This is done by setting the BOOST bit (Bit 2) in Configuration Register 3 (Address 0x78) to 1. This works only if the fan is already running, for example, in manual mode when the current duty cycle is above 0x00 or in automatic mode when the temperature is above T_{MIN} . If the temperature is below T_{MIN} or if the duty cycle in manual mode is set to 0x00, pulling $\overline{\text{THERM}}$ low externally has no effect. See Figure 37 for more information.

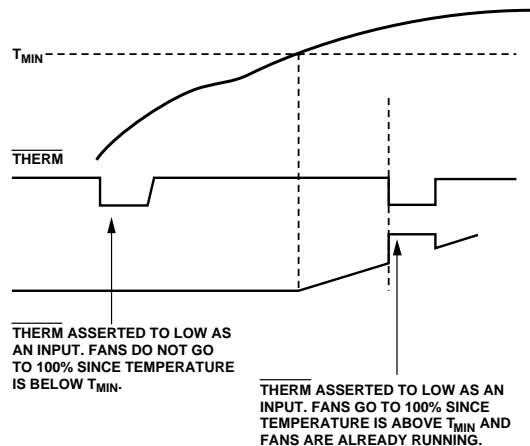

Figure 37. Asserting $\overline{\text{THERM}}$ Low as an Input in Automatic Fan Speed Control Mode

THERM TIMER

The ADT7460 has an internal timer to measure $\overline{\text{THERM}}$ assertion time. For example, the $\overline{\text{THERM}}$ input may be connected to the $\overline{\text{PROCHOT}}$ output of a Pentium 4 CPU and measure system performance. The $\overline{\text{THERM}}$ input may also be connected to the output of a trip point temperature sensor.

The timer is started on the assertion of the ADT7460's $\overline{\text{THERM}}$ input and stopped on the negation of the pin. The timer counts $\overline{\text{THERM}}$ times cumulatively, therefore, the timer resumes counting on the next $\overline{\text{THERM}}$ assertion. The $\overline{\text{THERM}}$ timer continues to accumulate $\overline{\text{THERM}}$ assertion times until the timer is read (it is cleared on read) or until it reaches full scale. If the counter reaches full scale, it stops at that reading until cleared.

The 8-bit $\overline{\text{THERM}}$ timer register (Reg. 0x79) is designed such that Bit 0 is set to 1 on the first $\overline{\text{THERM}}$ assertion. Once the cumulative $\overline{\text{THERM}}$ assertion time exceeds 45.52 ms, Bit 1 of the $\overline{\text{THERM}}$ timer is set and Bit 0 becomes the LSB of the timer with a resolution of 22.76 ms.

Figure 38 illustrates how the $\overline{\text{THERM}}$ timer behaves as the $\overline{\text{THERM}}$ input is asserted and negated. Bit 0 is set on the first $\overline{\text{THERM}}$ assertion detected. This bit remains set until the cumulative $\overline{\text{THERM}}$ assertions exceed 45.52 ms. At this time, Bit 1 of the $\overline{\text{THERM}}$ timer is set, and Bit 0 is cleared. Bit 0 now reflects timer readings with a resolution of 22.76 ms.

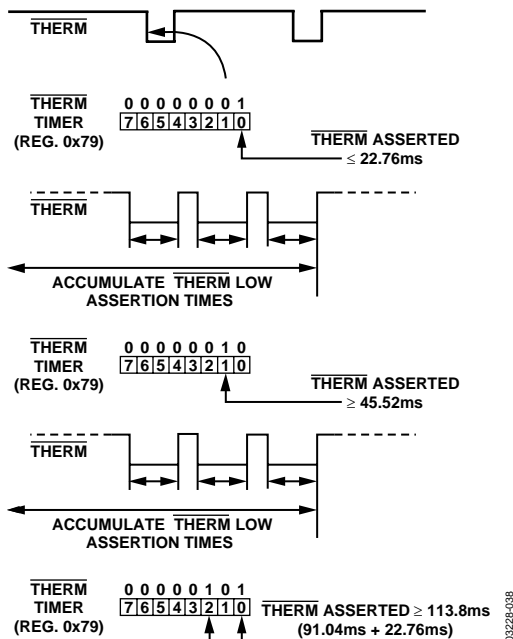

Figure 38. Understanding the $\overline{\text{THERM}}$ Timer

When using the $\overline{\text{THERM}}$ timer, be aware of the following:

After a $\overline{\text{THERM}}$ timer read (Reg. 0x79)

- The contents of the timer is cleared on read.
- The F4P bit (Bit 5) of Status Register 2 needs to be cleared (assuming the $\overline{\text{THERM}}$ limit has been exceeded).

If the $\overline{\text{THERM}}$ timer is read during a $\overline{\text{THERM}}$ assertion

- The contents of the timer are cleared.
- Bit 0 of the $\overline{\text{THERM}}$ timer is set to 1 (since a $\overline{\text{THERM}}$ assertion is occurring).
- The $\overline{\text{THERM}}$ timer increments from 0.
- If the $\overline{\text{THERM}}$ limit (Reg. 0x7A) = 0x00, the F4P bit is set.

Generating SMBALERT Interrupts from $\overline{\text{THERM}}$ Events

The ADT7460 can generate $\overline{\text{SMBALERT}}$ s when a programmable $\overline{\text{THERM}}$ limit has been exceeded. This allows the systems designer to ignore brief, infrequent $\overline{\text{THERM}}$ assertions while capturing longer $\overline{\text{THERM}}$ events. Register 0x7A is the $\overline{\text{THERM}}$ limit register. This 8-bit register allows a limit from 0 seconds (first $\overline{\text{THERM}}$ assertion) to 5.825 seconds to be set before an $\overline{\text{SMBALERT}}$ is generated. The $\overline{\text{THERM}}$ timer value is compared with the contents of the $\overline{\text{THERM}}$ limit register. If the $\overline{\text{THERM}}$ timer value exceeds the $\overline{\text{THERM}}$ limit value, the F4P bit (Bit 5) of Status Register 2 is set and an $\overline{\text{SMBALERT}}$ is generated. Note that the F4P bit (Bit 5) of Mask Register 2 (Reg. 0x75) masks out $\overline{\text{SMBALERT}}$ s if this bit is set to 1, although the F4P bit of Interrupt Status Register 2 is still set if the $\overline{\text{THERM}}$ limit is exceeded.

Figure 39 is a functional block diagram of the $\overline{\text{THERM}}$ timer, limit, and associated circuitry. Writing 0x00 to the $\overline{\text{THERM}}$ limit register (Reg. 0x7A) causes $\overline{\text{SMBALERT}}$ to be generated on the first $\overline{\text{THERM}}$ assertion. A $\overline{\text{THERM}}$ limit of 0x01 generates an $\overline{\text{SMBALERT}}$ once cumulative $\overline{\text{THERM}}$ assertions exceed 45.52 ms.

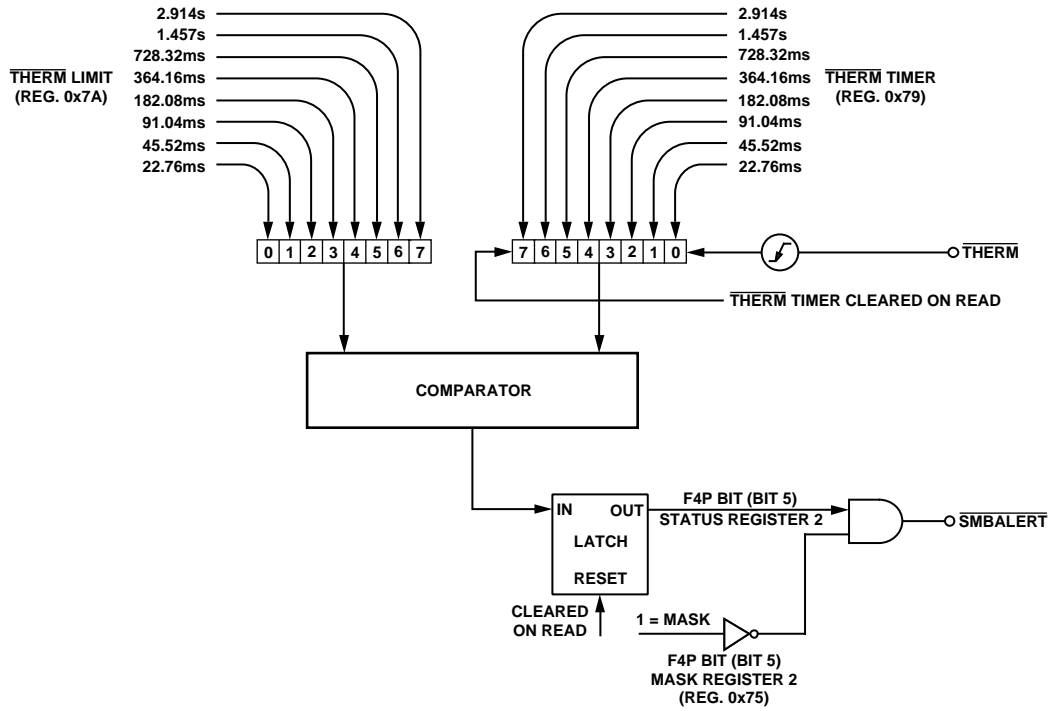

Figure 39. Functional Diagram of ADT7460's \overline{THERM} Monitoring Circuitry

00228-0319

Configuring the Desired THERM Behavior

1. Configure the THERM input.

Setting Bit 1 (THERM ENABLE) of Configuration Register 3 (Reg. 0x78) enables the THERM monitoring function.

2. Select the desired fan behavior for THERM events.

Setting Bit 2 (BOOST bit) of Configuration Register 3 (Reg. 0x78) causes all fans to run at 100% duty cycle whenever THERM is asserted. This allows fail-safe system cooling. If this bit = 0, the fans run at their current settings and are not affected by THERM events.

3. Select whether THERM events should generate SMBALERT interrupts.

Bit 5 (F4P) of Mask Register 2 (Reg. 0x75), when set, masks out SMBALERTs when the THERM limit value is exceeded. This bit should be cleared if SMBALERTs based on THERM events are required.

4. Select a suitable THERM limit value.

This value determines whether an SMBALERT is generated on the first THERM assertion, or only if a cumulative THERM assertion time limit is exceeded. A value of 0x00 causes an SMBALERT to be generated on the first THERM assertion.

5. Select a THERM monitoring time.

This is how often OS or BIOS level software checks the THERM timer. For example, BIOS could read the THERM timer once an hour to determine the cumulative THERM assertion time. If, for example, the total THERM assertion time is <22.76 ms in Hour 1, >182.08 ms in Hour 2, and >5.825 s in Hour 3, this can indicate that system performance is degrading significantly since THERM is asserting more frequently on an hourly basis.

Alternatively, OS or BIOS level software can time-stamp when the system is powered on. If an SMBALERT is generated due to the THERM limit being exceeded, another time-stamp can be taken. The difference in time can be calculated for a fixed THERM limit time. For example, if it takes one week for a THERM limit of 2.914 s to be exceeded and the next time it takes only one hour, this indicates a serious degradation in system performance.

Configuring the ADT7460 THERM Pin as an Output

In addition to the ADT7460 being able to monitor THERM as an input, the ADT7460 can optionally drive THERM low as an output. The user can preprogram system critical thermal limits. If the temperature exceeds a thermal limit by 0.25°C, THERM asserts low. If the temperature is still above the thermal limit on the next monitoring cycle, THERM stays low. THERM remains asserted low until the temperature is equal to or below the thermal limit. Since the temperature for that channel is measured only every monitoring cycle, once THERM asserts, it is guaranteed to remain low for at least one monitoring cycle.

The THERM pin can be configured to assert low if the Remote 1, local, or Remote 2 temperature THERM limits are exceeded by 0.25°C. The THERM limit registers are at Locations 0x6A, 0x6B, and 0x6C, respectively. Setting Bit 3 of Registers 0x5F, 0x60, and 0x61 enables the THERM output feature for the Remote 1, local, and Remote 2 temperature channels, respectively. Figure 40 shows how the THERM pin asserts low as an output in the event of a critical overtemperature.

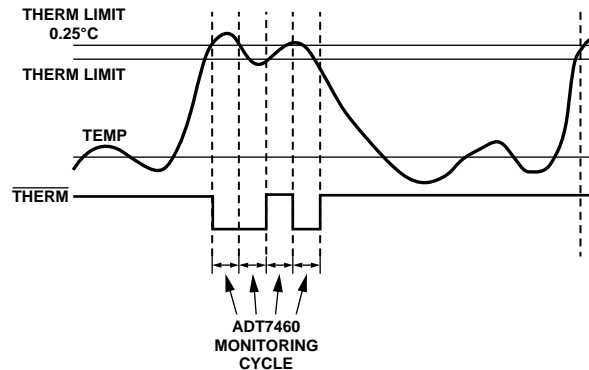

Figure 40. Asserting THERM as an Output, Based on Tripping THERM Limits

FAN DRIVE USING PWM CONTROL

The ADT7460 uses pulse width modulation (PWM) to control fan speed. This relies on varying the duty cycle (or on/off ratio) of a square wave applied to the fan to vary the fan speed. The external circuitry required to drive a fan using PWM control is extremely simple. A single NMOSFET is the only drive device required. The specifications of the MOSFET depend on the maximum current required by the fan being driven. Typical notebook fans draw a nominal 170 mA, so SOT devices can be used where board space is a concern. In desktops, fans can typically draw 250 mA to 300 mA each. If the user drives several fans in parallel from a single PWM output or drives larger server fans, the MOSFET needs to handle the higher current requirements. The only other stipulation is that the MOSFET should have a gate voltage drive, $V_{GS} < 3.3$ V, for direct interfacing to the PWM_OUT pin. V_{GS} can be greater than 3.3 V as long as the pull-up on the gate is tied to 5 V. The MOSFET should also have a low on resistance to ensure that there is not significant voltage drop across the FET. This would reduce the voltage applied across the fan and, therefore, the maximum operating speed of the fan.

Figure 41 shows how a 3-wire fan can be driven using PWM control.

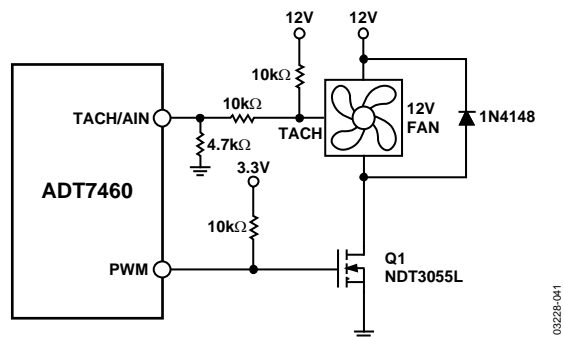

Figure 41. Driving a 3-Wire Fan by Using an N-Channel MOSFET

Figure 41 uses a 10 k Ω pull-up resistor for the TACH signal. This assumes that the TACH signal is open-collector from the fan. In all cases, the TACH signal from the fan must be kept below 5 V maximum to prevent damaging the ADT7460. If in doubt as to whether the fan used has an open-collector or totem pole TACH output, use one of the input signal conditioning circuits shown in the Fan Speed Measurement section.

Figure 42 shows a fan drive circuit using an NPN transistor such as a general-purpose MMBT2222. While these devices are inexpensive, they tend to have much lower current handling capabilities and higher on-resistance than MOSFETs. When choosing a transistor, care should be taken to ensure that it meets the fan's current requirements.

Ensure that the base resistor is chosen such that the transistor is saturated when the fan is powered on.

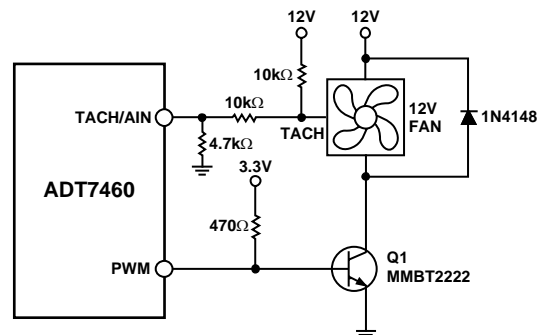

Figure 42. Driving a 3-Wire Fan by Using an NPN Transistor

Driving Two Fans from PWM3

Note that the ADT7460 has four TACH inputs available for fan speed measurement, but only three PWM drive outputs. If a fourth fan is being used in the system, it should be driven from the PWM3 output in parallel with the third fan. Figure 43 shows how to drive two fans in parallel using low cost NPN transistors. Figure 44 is the equivalent circuit using the NDT3055L MOSFET. Note that since the MOSFET can handle up to 3.5 A, it is simply a matter of connecting another fan directly in parallel with the first.

Care should be taken in designing drive circuits with transistors and FETs to ensure that the PWM pins are not required to source current and that they sink less than the 8 mA maximum current specified on the data sheet.

Driving Up to Three Fans from PWM2

TACH measurements for fans are synchronized to particular PWM channels, for example, TACH1 is synchronized to PWM1. TACH3 and TACH4 are both synchronized to PWM3, so PWM3 can drive two fans. Alternatively, PWM3 can be programmed to synchronize TACH2, TACH3, and TACH4 to the PWM3 output. This allows PWM3 to drive two or three fans. In this case, the drive circuitry looks the same as shown in Figure 42, Figure 43, and Figure 44. The SYNC bit in Register 0x62 enables this function.

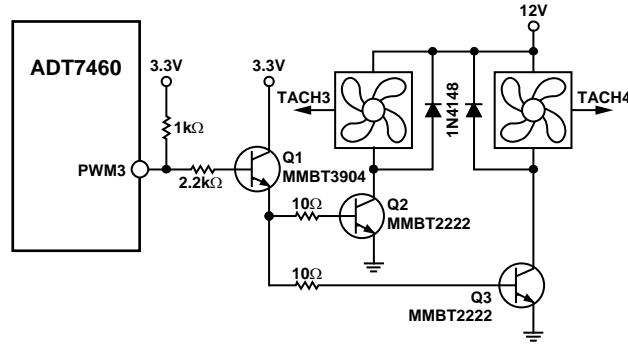

Figure 43. Interfacing Two Fans in Parallel to the PWM3 Output Using Low Cost NPN Transistors

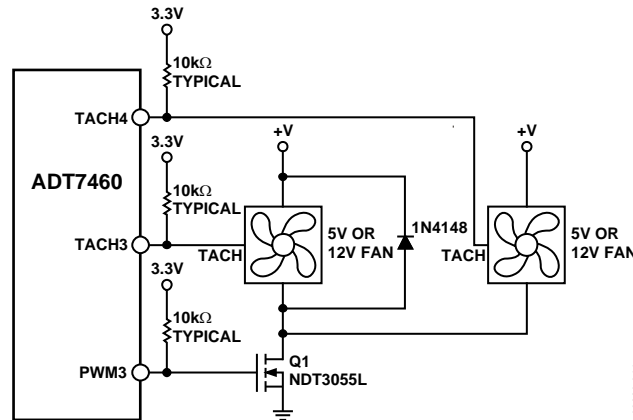

Figure 44. Interfacing Two Fans in Parallel to the PWM3 Output Using a Single N-Channel MOSFET

Table 29. SYNC : Enhance Acoustics Register 1 (Reg. 0x62)

Bit	Mnemonic	Description
<4>	SYNC	1 synchronizes TACH2, TACH3, and TACH4 to PWM3.

Driving 2-Wire Fans

Figure 45 shows how a 2-wire fan may be connected to the ADT7460. This circuit allows the speed of a 2-wire fan to be measured, even though the fan has no dedicated TACH signal. A series resistor, R_{SENSE} , in the fan circuit converts the fan commutation pulses into a voltage. This is ac-coupled into the ADT7460 through the 0.01 μ F capacitor. On-chip signal conditioning allows accurate monitoring of fan speed. The value of R_{SENSE} chosen depends on the programmed input threshold and on the current drawn by the fan. For fans drawing approximately 200 mA, a 2 Ω R_{SENSE} value is suitable when the threshold is programmed as 40 mV. For fans that draw more current, such as larger desktop or server fans, R_{SENSE} may be reduced for the same programmed threshold. The smaller the threshold programmed the better, since more voltage is developed across the

fan and the fan spins faster. Figure 46 shows a typical plot of the sensing waveform at a TACH/AIN pin. The most important thing is that the voltage spikes (either negative going or positive going) are more than 40 mV in amplitude. This allows fan speed to be reliably determined.

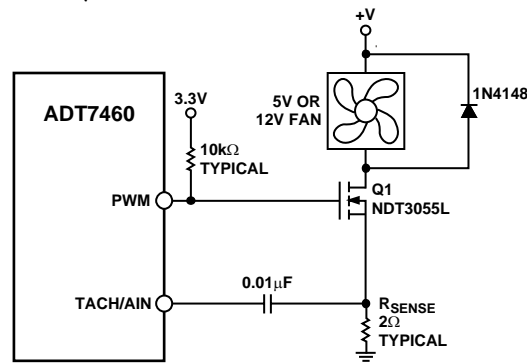

Figure 45. Driving a 2-Wire Fan

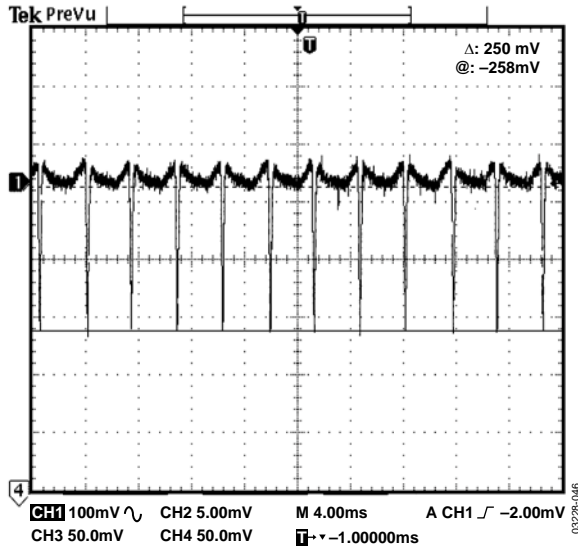

Figure 46. Fan Speed Sensing Waveform at TACH/AIN Pin

Laying Out 2-Wire and 3-Wire Fans

Figure 47 shows how to lay out a common circuit arrangement for 2-wire and 3-wire fans. Some components are not populated, depending on whether a 2-wire or 3-wire fan is used.

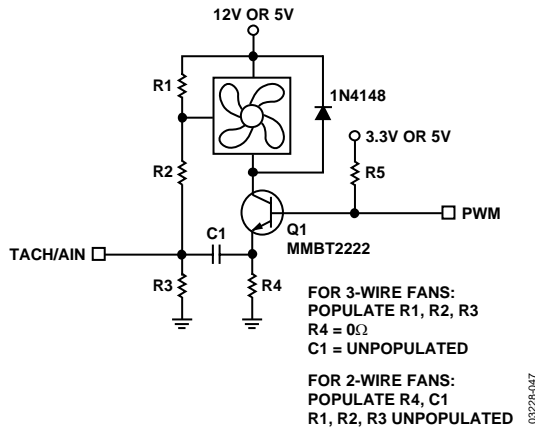

Figure 47. Planning for 2-Wire or 3-Wire Fans on a PCB

TACH Inputs

Pins 4, 6, 7, and 9 are open-drain TACH inputs for fan speed measurement.

Signal conditioning in the ADT7460 accommodates the slow rise and fall times typical of fan tachometer outputs. The maximum input signal range is 0 V to 5 V, even where V_{CC} is less than 5 V. In the event that these inputs are supplied from fan outputs that exceed 0 V to 5 V, either resistive attenuation of the fan signal or diode clamping must be included to keep inputs within an acceptable range.

Figure 48 to Figure 51 show circuits for most common fan TACH outputs.

If the fan TACH output has a resistive pull-up to V_{CC}, it can be connected directly to the fan input, as shown in Figure 48.

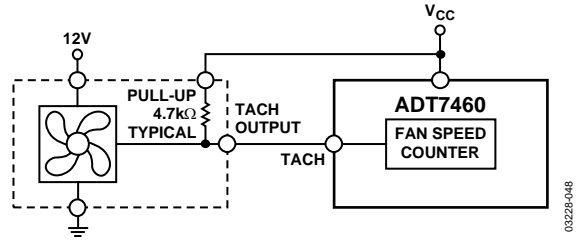

Figure 48. Fan with TACH Pull-Up to V_{CC}

If the fan output has a resistive pull-up to 12 V (or other voltage greater than 5 V), the fan output can be clamped with a Zener diode, as shown in Figure 49. The Zener diode voltage should be greater than V_{IH} of the TACH input but less than 5 V, allowing for the voltage tolerance of the Zener. A value of between 3 V and 5 V is suitable.

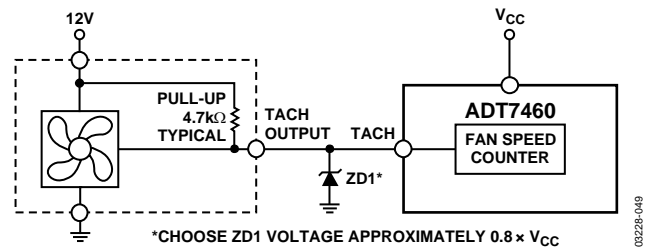

Figure 49. Fan with TACH Pull-Up to Voltage . 5 V, for example, 12 V, Clamped with Zener Diode

If the fan has a strong pull-up (less than 1 kΩ) to 12 V or a totem-pole output, a series resistor can be added to limit the Zener current, as shown in Figure 50. Alternatively, a resistive attenuator may be used, as shown in Figure 51. R1 and R2 should be chosen such that

$$2 V < V_{PULLUP} \times R2 / (R_{PULLUP} + R1 + R2) < 5 V$$

The fan inputs have an input resistance of nominally 160 kΩ to ground. This should be taken into account when calculating resistor values.

With a pull-up voltage of 12 V and pull-up resistor less than 1 kΩ, suitable values for R1 and R2 would be 100 kΩ and 47 kΩ. This gives a high input voltage of 3.83 V.

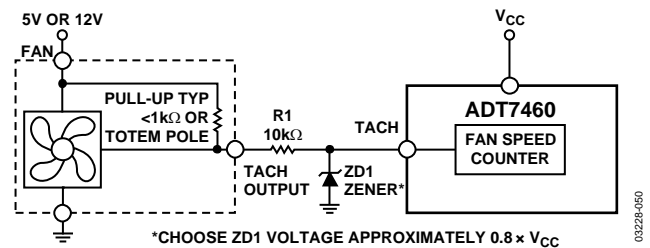

Figure 50. Fan with Strong TACH Pull-Up to > V_{CC} or Totem-Pole Output, Clamped with Zener and Resistor

ADT7460

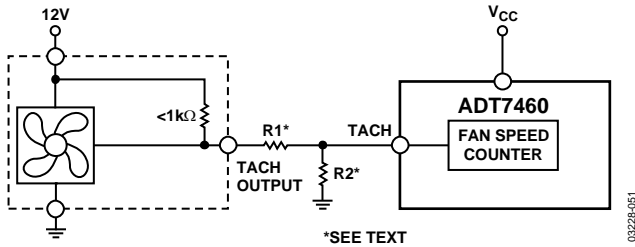

Figure 51. Fan with Strong TACH Pull-Up to $> V_{CC}$ or Totem-Pole Output, Attenuated with R1/R2

Fan Speed Measurement

The fan counter does not count the fan TACH output pulses directly because the fan speed may be less than 1000 RPM. It would take several seconds to accumulate a reasonably large and accurate count. Instead, the period of the fan revolution is measured by gating an on-chip 90 kHz oscillator into the input of a 16-bit counter for N periods of the fan TACH output (Figure 52). The accumulated count is actually proportional to the fan tachometer period and inversely proportional to the fan speed.

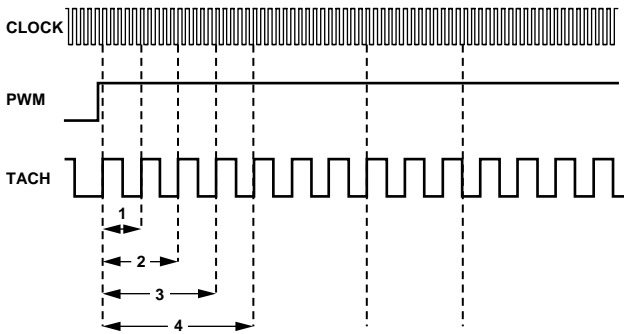

Figure 52. Fan Speed Measurement

N, the number of pulses counted, is determined by the settings of Register 0x7B (fan pulses per revolution register). This register contains two bits for each fan, allowing one, two (default), three, or four TACH pulses to be counted.

The fan tachometer readings are 16-bit values consisting of a 2-byte read from the ADT7460.

Table 30. Fan Speed Measurement Registers

Register	Description	Default
0x28	TACH1 low byte	0x00
0x29	TACH1 high byte	0x00
0x2A	TACH2 low byte	0x00
0x2B	TACH2 high byte	0x00
0x2C	TACH3 low byte	0x00
0x2D	TACH3 high byte	0x00
0x2E	TACH4 Low byte	0x00
0x2F	TACH4 high byte	0x00

Reading Fan Speed from the ADT7460

If fan speeds are being measured, this involves a 2-register read for each measurement. The low byte should be read first. This causes the high byte to be frozen until both high and low byte registers are read from. This prevents erroneous TACH readings.

The fan tachometer reading registers report the number of 11.11 μ s period clocks (90 kHz oscillator) gated to the fan speed counter, from the rising edge of the first fan TACH pulse to the rising edge of the third fan TACH pulse (assuming two pulses per revolution are being counted). Since the device is essentially measuring the fan TACH period, the higher the count value the slower the fan is actually running. A 16-bit fan tachometer reading of 0xFFFF indicates either that the fan has stalled or that it is running very slowly (<100 RPM).

High Limit: $>$ Comparison Performed

Since the actual fan TACH period is being measured, exceeding a fan TACH limit by 1 sets the appropriate status bit and can be used to generate an SMBALERT.

The fan TACH limit registers are 16-bit values consisting of two bytes.

Table 31. Fan TACH Limit Registers

Register	Description	Default
0x54	TACH1 minimum low byte	0xFF
0x55	TACH1 minimum high byte	0xFF
0x56	TACH2 minimum low byte	0xFF
0x57	TACH2 minimum high byte	0xFF
0x58	TACH3 minimum low byte	0xFF
0x59	TACH3 minimum high byte	0xFF
0x5A	TACH4 minimum low byte	0xFF
0x5B	TACH4 minimum high byte	0xFF

Fan Speed Measurement Rate

The fan TACH readings are normally updated once every second.

The FAST bit (Bit 3) of Configuration Register 3 (Reg. 0x78), when set, updates the fan TACH readings every 250 ms.

If any of the fans are not being driven by a PWM channel but are instead powered directly from 5 V or 12 V, its associated dc bit in Configuration Register 3 should be set. This allows TACH readings to be taken on a continuous basis for fans connected directly to a dc source.

Calculating Fan Speed

Assuming a fan with a two pulses/revolution (and two pulses/revolution being measured), fan speed is calculated by

$$\text{Fan Speed (RPM)} = 90,000 \times 60 / \text{Fan TACH Reading}$$

where:

$$\text{Fan TACH Reading} = 16\text{-Bit Fan Tachometer Reading}$$

For example:

$$\text{TACH1 High Byte (Reg. 0x29)} = 0x17$$

$$\text{TACH1 Low Byte (Reg. 0x28)} = 0xFF$$

What is Fan 1 speed in RPM?

$$\text{Fan 1 TACH Reading} = 0x17FF = 6143d$$

$$\text{RPM} = (f \times 60) / \text{Fan 1 TACH Reading}$$

$$\text{RPM} = (90000 \times 60) / 6143$$

$$\text{Fan Speed} = 879 \text{ RPM}$$

Fan Pulses per Revolution

Different fan models can output either 1, 2, 3, or 4 TACH pulses per revolution. Once the number of fan TACH pulses is determined, it can be programmed into the fan pulses per revolution register (Reg. 0x7B) for each fan. Alternatively, this register can be used to determine the number of pulses/revolution output by a given fan. By plotting fan speed measurements at 100% speed with different pulses/revolution settings, the smoothest graph with the lowest ripple determines the correct pulses/revolution value.

Table 32. Fan Pulses per Revolution Register (Reg. 0x7B)

Bit	Mnemonic	Description
<1:0>	FAN1 Default	2 pulses per revolution
<3:2>	FAN2 Default	2 pulses per revolution
<5:4>	FAN3 Default	2 pulses per revolution
<7:6>	FAN4 Default	2 pulses per revolution

Table 33. Fan Pulses per Revolution Register Bit Values

Value	Description
00	1 pulse per revolution
01	2 pulses per revolution
10	3 pulses per revolution
11	4 pulses per revolution

2-Wire Fan Speed Measurements

The ADT7460 is capable of measuring the speed of 2-wire fans, that is, fans without TACH outputs. To do this, the fan must be interfaced as shown in the Fan Drive Circuitry section. In this case, the TACH inputs need to be reprogrammed as analog inputs, AIN.

Table 34. Configuration Register 2 (Reg. 0x73)

Bit	Mnemonic	Description
3	AIN4	1 indicates that Pin 9 is reconfigured to measure the speed of a 2-wire fan using an external sensing resistor and coupling capacitor.
2	AIN3	1 indicates that Pin 4 is reconfigured to measure the speed of a 2-wire fan using an external sensing resistor and coupling capacitor.
1	AIN2	1 indicates that Pin 7 is reconfigured to measure the speed of a 2-wire fan using an external sensing resistor and coupling capacitor.
0	AIN1	1 indicates that Pin 6 is reconfigured to measure the speed of a 2-wire fan using an external sensing resistor and coupling capacitor.

AIN Switching Threshold

Having configured the TACH inputs as AIN inputs for 2-wire measurements, the user can select the sensing threshold for the AIN signal.

Table 35. Configuration Register 4 (Reg. 0x7D)

Bit	Mnemonic	Description
<3:2>	AINL	These two bits define the input threshold for 2-wire fan speed measurements. 00 = ±20 mV 01 = ±40 mV 10 = ±80 mV 11 = ±130 mV

Fan Spin-Up

The ADT7460 has a unique fan spin-up function. It spins the fan at 100% PWM duty cycle until two TACH pulses are detected on the TACH input. Once two pulses are detected, the PWM duty cycle goes to the expected running value, for example, 33%. The advantage of this is that fans have different spin-up characteristics and take different amounts of time to overcome inertia. The ADT7460 runs the fans just fast enough to overcome inertia and is quieter on spin-up than fans programmed to spinup for a given spin-up time.

Fan Start-Up Timeout

To prevent false interrupts being generated as a fan spins up (since it is below running speed), the ADT7460 includes a fan start-up timeout function. This is the time limit allowed for two TACH pulses to be detected on spin-up. For example, if 2 seconds fan start-up timeout is chosen and no TACH pulses occur within 2 seconds of the start of spin-up, a fan fault is detected and flagged in the interrupt status registers.

Table 36. PWM1–PWM3 Configuration (Reg. 0x5C–0x5E)

Bit	Mnemonic	Description
<2:0>	SPIN	These bits control the start-up timeout for PWM1. 000 = no start-up timeout 001 = 100 ms 010 = 250 ms (default) 011 = 400 ms 100 = 667 ms 101 = 1 s 110 = 2 s 111 = 4 s

Disabling Fan Start-Up Timeout

Although fan start-up makes fan spin-ups much quieter than fixed-time spin-ups, the option exists to use fixed spin-up times. Bit 5 (FSPDIS) = 1 in Configuration Register 1 (Reg. 0x40) disables the spin-up for two TACH pulses. Instead, the fan spins up for the fixed time as selected in Registers 0x5C to 0x5E.

PWM Logic State

The PWM outputs can be programmed high for 100% duty cycle (noninverted) or low for 100% duty cycle (inverted).

Table 37. PWM1–PWM3 Configuration (Reg. 0x5C–0x5E) Bits

Bit	Mnemonic	Description
<4>	INV	0 = logic high for 100% PWM duty cycle 1 = logic low for 100% PWM duty cycle

PWM Drive Frequency

The PWM drive frequency can be adjusted for the application. Registers 0x5F to 0x61 configure the PWM frequency for PWM1 to PWM3, respectively.

Table 38. PWM1 to PWM3 Frequency Registers (Reg. 0x5F to 0x61)

Bit	Mnemonic	Description
<2:0>	FREQ	000 = 11.0 Hz 001 = 14.7 Hz 010 = 22.1 Hz 011 = 29.4 Hz 100 = 35.3 Hz (default) 101 = 44.1 Hz 110 = 58.8 Hz 111 = 88.2 Hz

Fan Speed Control

The ADT7460 can control fan speed by two different modes. The first is automatic fan speed control mode. In this mode, fan speed is automatically varied with temperature and without CPU intervention, once initial parameters are set up. The advantage of this is that, in the case of the system hanging, the system is protected from overheating. The automatic fan speed control incorporates a feature called dynamic T_{MIN} calibration. This feature reduces the design effort required to program the automatic fan speed control loop. For more information on how to program the automatic fan speed control loop and dynamic T_{MIN} calibration, see the AN-613 Programming the Automatic Fan Speed Control Loop application note (http://www.analog.com/UploadedFiles/Application_Notes/331085006AN613_0.pdf).

The second fan speed control method is manual fan speed control, which is described next.

Manual Fan Speed Control

The ADT7460 allows the duty cycle of any PWM output to be manually adjusted. This can be useful if you want to change fan speed in software or if you want to adjust PWM duty cycle output for test purposes. Bits <7:5> of Registers 0x5C, 0x5E (PWM configuration) control the behavior of each PWM output.

Table 39. PWM1 to PWM3 Configuration (Reg. 0x5C–0x5E) Bits

Bit	Mnemonic	Description
<7:5>	BHVR 111	Manual mode

Once under manual control, each PWM output can be manually updated by writing to Registers 0x30, 0x32 (PWMx current duty cycle registers).

Programming the PWM Current Duty Cycle Registers

The PWM current duty cycle registers are 8-bit registers, which allow the PWM duty cycle for each output to be set anywhere from 0% (0x00) to 100% (0xFF) in steps of 0.39% (256 steps).

The value to be programmed into the PWMMIN register is given by

$$\text{Value (decimal)} = \text{PWM}_{MIN} / 0.39$$

Example 1: For a PWM duty cycle of 50%,

$$\text{Value (decimal)} = 50 / 0.39 = 128d$$

$$\text{Value} = 128d \text{ or } 0x80.$$

Example 2: For a PWM duty cycle of 33%,

$$\text{Value (decimal)} = 33 / 0.39 = 85d$$

$$\text{Value} = 85d \text{ or } 0x54.$$

Table 40. PWM Duty Cycle Registers

Register	Description	Default
0x30	PWM1 duty cycle	0xFF (100%)
0x31	PWM2 duty cycle	0xFF (100%)
0x32	PWM3 duty cycle	0xFF (100%)

By reading the PWMx current duty cycle registers, users can keep track of the current duty cycle on each PWM output, even when the fans are running in automatic fan speed control mode or in acoustic enhancement mode.

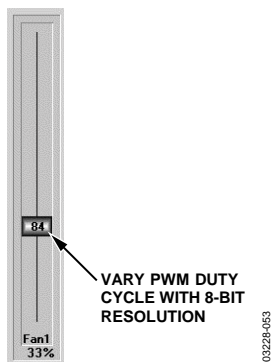

Figure 53. Control PWM Duty Cycle Manually with a Resolution of 0.39%

OPERATING FROM 3.3 V STANDBY

The ADT7460 has been specifically designed to operate from a 3.3 V STBY supply. In computers that support S3 and S5 states, the core voltage of the processor is lowered in these states. If using the dynamic TMIN mode, lowering the core voltage of the processor would change the CPU temperature and change the dynamics of the system under dynamic TMIN control. Likewise, when monitoring THERM, the THERM timer should be disabled during these states.

XNOR TREE TEST MODE

The ADT7460 includes an XNOR tree test mode. This mode is useful for in-circuit test equipment at board-level testing. By applying stimulus to the pins included in the XNOR tree, it is possible to detect opens or shorts on the system board. Figure 54 shows the signals that are exercised in the XNOR tree test mode.

The XNOR tree test is invoked by setting Bit 0 (XEN) of the XNOR tree test enable register (Reg. 0x6F).

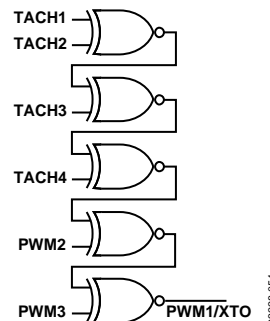

Figure 54. XNOR Tree Test

POWER-ON DEFAULT

The ADT7460 does not monitor temperature and fan speed by default on power-up. Monitoring of temperature and fan speed is enabled by setting the start bit in configuration Register 1 (Bit 0, Address 0x40) to 1. The fans run at full speed on power-up. This is because the BHVR bits (Bits <7:5>) in the PWMx configuration registers are set to 100 (fans run full speed) by default.

ADT7460 REGISTER SUMMARY

Table 41. ADT7460 Registers

Address	R/W	Description	Bit 7	Bit 6	Bit 5	Bit 4	Bit 3	Bit 2	Bit 1	Bit 0	Default	Lockable?
0x20	R	2.5 V Reading	9	8	7	6	5	4	3	2	0x00	
0x22	R	V _{CC} Reading	9	8	7	6	5	4	3	2	0x00	
0x25	R	Remote 1 Temperature	9	8	7	6	5	4	3	2	0x80	
0x26	R	Local Temperature	9	8	7	6	5	4	3	2	0x80	
0x27	R	Remote 2 Temperature	9	8	7	6	5	4	3	2	0x80	
0x28	R	TACH1 Low Byte	7	6	5	4	3	2	1	0	0x00	
0x29	R	TACH1 High Byte	15	14	13	12	11	10	9	8	0x00	
0x2A	R	TACH2 Low Byte	7	6	5	4	3	2	1	0	0x00	
0x2B	R	TACH2 High Byte	15	14	13	12	11	10	9	8	0x00	
0x2C	R	TACH3 Low Byte	7	6	5	4	3	2	1	0	0x00	
0x2D	R	TACH3 High Byte	15	14	13	12	11	10	9	8	0x00	
0x2E	R	TACH4 Low Byte	7	6	5	4	3	2	1	0	0x00	
0x2F	R	TACH4 High Byte	15	14	13	12	11	10	9	8	0x00	
0x30	R/W	PWM1 Current Duty Cycle	7	6	5	4	3	2	1	0	0xFF	
0x31	R/W	PWM2 Current Duty Cycle	7	6	5	4	3	2	1	0	0xFF	
0x32	R/W	PWM3 Current Duty Cycle	7	6	5	4	3	2	1	0	0xFF	
0x33	R/W	Remote 1 Operating Point	7	6	5	4	3	2	1	0	0x64	YES
0x34	R/W	Local Temp Operating Point	7	6	5	4	3	2	1	0	0x64	YES
0x35	R/W	Remote 2 Operating Point	7	6	5	4	3	2	1	0	0x64	YES
0x36	R/W	Dynamic T _{MIN} Control Reg. 1	R2T	LT	R1T	PHTR2	PHTL	PHTR1	V _{CC} RES	CYR2	0x00	YES
0x37	R/W	Dynamic T _{MIN} Control Reg. 2	CYR2	CYR2	CYL	CYL	CYL	CYR1	CYR1	CYR1	0x00	YES
0x3D	R	Device ID Register	7	6	5	4	3	2	1	0	0x27	
0x3E	R	Company ID Number	7	6	5	4	3	2	1	0	0x41	
0x3F	R	Revision Number	VER	VER	VER	VER	STP	STP	STP	STP	0x62 or 0x6A	
0x40	R/W	Configuration Register 1	V _{CC}	TODIS	FSPDIS	RES	FSPD	RDY	LOCK	STRT	0x00	YES
0x41	R	Interrupt Status Register 1	OOL	R2T	LT	R1T	RES	V _{CC}	RES	2.5V	0x00	
0x42	R	Interrupt Status Register 2	D2	D1	5	FAN3	FAN2	FAN1	OVT	RES	0x00	
0x44	R/W	2.5 V Low Limit	7	6	5	4	3	2	1	0	0x00	
0x45	R/W	2.5 V High Limit	7	6	5	4	3	2	1	0	0xFF	
0x48	R/W	V _{CC} Low Limit	7	6	5	4	3	2	1	0	0x00	
0x49	R/W	V _{CC} High Limit	7	6	5	4	3	2	1	0	0xFF	
0x4E	R/W	Remote 1 Temp Low Limit	7	6	5	4	3	2	1	0	0x81	
0x4F	R/W	Remote 1 Temp High Limit	7	6	5	4	3	2	1	0	0x7F	
0x50	R/W	Local Temp Low Limit	7	6	5	4	3	2	1	0	0x81	
0x51	R/W	Local Temp High Limit	7	6	5	4	3	2	1	0	0x7F	
0x52	R/W	Remote 2 Temp Low Limit	7	6	5	4	3	2	1	0	0x81	
0x53	R/W	Remote 2 Temp High Limit	7	6	5	4	3	2	1	0	0x7F	
0x54	R/W	TACH1 Minimum Low Byte	7	6	5	4	3	2	1	0	0xFF	
0x55	R/W	TACH1 Minimum High Byte	15	14	13	12	11	10	9	8	0xFF	
0x56	R/W	TACH2 Minimum Low Byte	7	6	5	4	3	2	1	0	0xFF	
0x57	R/W	TACH2 Minimum High Byte	15	14	13	12	11	10	9	8	0xFF	
0x58	R/W	TACH3 Minimum Low Byte	7	6	5	4	3	2	1	0	0xFF	
0x59	R/W	TACH3 Minimum High Byte	15	14	13	12	11	10	9	8	0xFF	
0x5A	R/W	TACH4 Minimum Low Byte	7	6	5	4	3	2	1	0	0xFF	
0x5B	R/W	TACH4 Minimum High Byte	15	14	13	12	11	10	9	8	0xFF	
0x5C	R/W	PWM1 Configuration Register	BHVR	BHVR	BHVR	INV	SLOW	SPIN	SPIN	SPIN	0x62	YES
0x5D	R/W	PWM2 Configuration Register	BHVR	BHVR	BHVR	INV	SLOW	SPIN	SPIN	SPIN	0x62	YES
0x5E	R/W	PWM3 Configuration Register	BHVR	BHVR	BHVR	INV	SLOW	SPIN	SPIN	SPIN	0x62	YES
0x5F	R/W	Remote 1 T _{RANGE} /PWM 1 Freq.	RANGE	RANGE	RANGE	RANGE	THRM	FREQ	FREQ	FREQ	0xC4	YES
0x60	R/W	Local T _{RANGE} /PWM 2 Freq.	RANGE	RANGE	RANGE	RANGE	THRM	FREQ	FREQ	FREQ	0xC4	YES
0x61	R/W	Remote 2 T _{RANGE} /PWM 3 Freq.	RANGE	RANGE	RANGE	RANGE	THRM	FREQ	FREQ	FREQ	0xC4	YES
0x62	R/W	Enhance Acoustics Reg. 1	MIN3	MIN2	MIN1	SYNC	EN1	ACOU	ACOU	ACOU	0x00	YES
0x63	R/W	Enhance Acoustics Reg. 2	EN2	ACOU2	ACOU2	ACOU2	EN3	ACOU3	ACOU3	ACOU3	0x00	YES
0x64	R/W	PWM1 Min Duty Cycle	7	6	5	4	3	2	1	0	0x80	YES
0x65	R/W	PWM2 Min Duty Cycle	7	6	5	4	3	2	1	0	0x80	YES
0x66	R/W	PWM3 Min Duty Cycle	7	6	5	4	3	2	1	0	0x80	YES

Address	R/W	Description	Bit 7	Bit 6	Bit 5	Bit 4	Bit 3	Bit 2	Bit 1	Bit 0	Default	Lockable?	
0x67	R/W	Remote 1 Temp T _{MIN}	7	6	5	4	3	2	1	0	0x5A	YES	
0x68	R/W	Local Temp T _{MIN}	7	6	5	4	3	2	1	0	0x5A	YES	
0x69	R/W	Remote 2 Temp T _{MIN}	7	6	5	4	3	2	1	0	0x5A	YES	
0x6A	R/W	Remote 1 THERM Limit	7	6	5	4	3	2	1	0	0x64	YES	
0x6B	R/W	Local THERM Limit	7	6	5	4	3	2	1	0	0x64	YES	
0x6C	R/W	Remote 2 THERM Limit	7	6	5	4	3	2	1	0	0x64	YES	
0x6D	R/W	Remote 1 Local Hysteresis	HYSR1	HYSR1	HYSR1	HYSR1	HYSL	HYSL	HYSL	HYSL	0x44	YES	
0x6E	R/W	Remote 2 Temp Hysteresis	HYSR2	HYSR2	HYSR2	HYSR2	RES	RES	RES	RES	0x40	YES	
0x6F	R/W	XNOR Tree Test Enable	RES	RES	RES	RES	RES	RES	RES	XEN	0x00	YES	
0x70	R/W	Remote 1 Temperature Offset	7	6	5	4	3	2	1	0	0x00	YES	
0x71	R/W	Local Temperature Offset	7	6	5	4	3	2	1	0	0x00	YES	
0x72	R/W	Remote 2 Temperature Offset	7	6	5	4	3	2	1	0	0x00	YES	
0x73	R/W	Configuration Register 2	SHDN	CONV	ATTN	AVG	AIN4	AIN3	AIN2	AIN1	0x00	YES	
0x74	R/W	Interrupt Mask Register 1	OOL	R2T	LT	R1T	RES	V _{CC}	RES	2.5V	0x00		
0x75	R/W	Interrupt Mask Register 2	D2	D1	F4P	FAN3	FAN2	FAN1	OVT	RES	0x00		
0x76	R/W	Extended Resolution 1	RES	RES	V _{CC}	V _{CC}	RES	RES	2.5V	2.5V	0x00		
0x77	R/W	Extended Resolution 2	TDM2	TDM2	LTMP	LTMP	TDM1	TDM1	RES	RES	0x00		
0x78	R/W	Configuration Register 3	DC4	DC3	DC2	DC1	FAST	BOOST	THERM ENABLE	ALERT	0x00	YES	
0x79	R	THERM Status Register	TMR	TMR	TMR	TMR	TMR	TMR	TMR	ASRT/TMR	0x00		
0x7A	R/W	THERM Limit Register	LIMIT	LIMIT	LIMIT	LIMIT	LIMIT	LIMIT	LIMIT	LIMIT	0x00		
0x7B	R/W	Fan Pulses per Revolution	FAN4	FAN4	FAN3	FAN3	FAN2	FAN2	FAN1	FAN1	0x55		
0x7D	R/W	Configuration Register 4	RES	RES	RES	RES	AINL	AINL	RES	AL2.5V	0x00	YES	
0x7E	R	Test Register 1	DO NOT WRITE TO THESE REGISTERS									0x00	YES
0x7F	R	Test Register 2	DO NOT WRITE TO THESE REGISTERS									0x00	YES

Table 42. Voltage Reading Registers (Power-On Default = 0x00)

Register Address	R/W	Description
0x20	Read-Only	2.5 V Reading (8 MSBs of reading)
0x22	Read-Only	V _{CC} Reading: Measures V _{CC} through the V _{CC} pin (8 MSBs of reading)

These voltage readings are in twos complement format.

If the extended resolution bits of these readings are also being read, the extended resolution registers (Reg. 0x76, 0x77) should be read first. Once the extended resolution registers are read, the associated MSB reading registers are frozen until read. Both the extended resolution registers and the MSB registers are frozen.

Table 43. Temperature Reading Registers (Power-On Default = 0x80)

Register Address	R/W	Description
0x25	Read-Only	Remote 1 Temperature Reading ¹ (8 MSBs of reading)
0x26	Read-Only	Local Temperature Reading (8 MSBs of reading)
0x27	Read-Only	Remote 2 Temperature Reading (8 MSBs of reading)

These voltage readings are in twos complement format.

¹ Note that a reading of 0x80 in a temperature reading register indicates a diode fault (open or short) on that channel. If the extended resolution bits of these readings are also being read, the extended resolution registers (Reg. 0x76, 0x77) should be read first. Once the extended resolution registers are read, all associated MSB reading registers are frozen until read. Both the extended resolution registers and the MSB registers are frozen.

ADT7460

Table 44. Fan Tachometer Reading Registers (Power-On Default = 0x00)

Register Address	R/W	Description
0x28	Read-Only	TACH1 Low Byte
0x29	Read-Only	TACH1 High Byte
0x2A	Read-Only	TACH2 Low Byte
0x2B	Read-Only	TACH2 High Byte
0x2C	Read-Only	TACH3 Low Byte
0x2D	Read-Only	TACH3 High Byte
0x2E	Read-Only	TACH4 Low Byte
0x2F	Read-Only	TACH4 High Byte

The Fan Tachometer Reading registers count the number of 11.11 μ s periods (based on an internal 90 kHz clock) that occur between a number of consecutive fan TACH pulses (default = 2).

The number of TACH pulses used to count can be changed using the fan pulses per revolution register (Reg. 0x7B). This allows the fan speed to be accurately measured. Since a valid fan tachometer reading requires that two bytes are read, the low byte MUST be read first. Both the low and high bytes are then frozen until read. At power-on, these registers contain 0x0000 until such time as the first valid fan TACH measurement is read in to these registers. This prevents false interrupts from occurring while the fans are spinning up.

A count of 0xFFFF indicates that a fan is

1. **Stalled or Blocked** (object jamming the fan)
2. **Failed** (internal circuitry destroyed)
3. **Not Populated** (The ADT7460 expects to see a fan connected to each TACH. If a fan is not connected to that TACH, its TACH minimum high and low byte should be set to 0xFFFF.)
4. **Alternate Function**, for example, TACH4 reconfigured as THERM pin
5. **2-Wire Instead of 3-Wire Fan**

Table 45. Current PWM Duty Cycle Registers (Power-On Default = 0xFF)

Register Address	R/W	Description
0x30	Read/Write	PWM1 Current Duty Cycle (0% to 100% Duty Cycle = 0x00 to 0xFF)
0x31	Read/Write	PWM2 Current Duty Cycle (0% to 100% Duty Cycle = 0x00 to 0xFF)
0x32	Read/Write	PWM3 Current Duty Cycle (0% to 100% Duty Cycle = 0x00 to 0xFF)

These registers reflect the PWM duty cycle driving each fan at any given time. When in automatic fan speed control mode, the ADT7460 reports the PWM duty cycles back through these registers. The PWM duty cycle values vary according to temperature in automatic fan speed control mode. During fan startup, these registers report back 0x00. In software mode, the PWM duty cycle outputs can be set to any duty cycle value by writing to these registers.

Table 46. Operating Point Registers (Power-On Default = 0x64)

Register Address	R/W	Description
0x33	Read/Write	Remote 1 Operating Point Register (Default = 100°C)
0x34	Read/Write	Local Temp Operating Point Register (Default = 100°C)
0x35	Read/Write	Remote 2 Operating Point Register (Default = 100°C)

These registers become read-only when the Configuration Register 1 lock bit is set to 1. Any subsequent attempts to write to these registers will fail.

These registers set the target operating point for each temperature channel when the dynamic T_{MIN} control feature is enabled. The fans being controlled are adjusted to maintain temperature about an operating point.

Table 47. Register 0x36—Dynamic T_{MIN} Control Register 1 (Power-On Default = 0x00)

Bit	Name	R/W	Description
<0>	CYR2	Read/Write	MSB of 3-Bit Remote 2 Cycle Value. The other two bits of the code reside in Dynamic T _{MIN} Control Register 2 (Reg. 0x37). These three bits define the delay time between making subsequent T _{MIN} adjustments in the control loop, in terms of number of monitoring cycles. The system has associated thermal time constants that need to be found to optimize the response of fans and the control loop.
<1>	Reserved	Read-Only	Reserved for future use.
<2>	PHTR1	Read/Write	PHTR1 = 1 copies the Remote 1 current temperature to the Remote 1 operating point register if $\overline{\text{THERM}}$ is asserted. The operating point contains the temperature at which $\overline{\text{THERM}}$ is asserted. This allows the system to run as quietly as possible without affecting system performance. PHTR1 = 0 ignores any $\overline{\text{THERM}}$ assertions on the $\overline{\text{THERM}}$ pin. The Remote 1 operating point register reflects its programmed value.
<3>	PHTL	Read/Write	PHTL = 1 copies the local channel's current temperature to the local operating point register if $\overline{\text{THERM}}$ is asserted. The operating point contains the temperature at which $\overline{\text{THERM}}$ is asserted. This allows the system to run as quietly as possible without affecting system performance. PHTL = 0 ignores any $\overline{\text{THERM}}$ assertions on the $\overline{\text{THERM}}$ pin. The local temperature operating point register reflects its programmed value.
<4>	PHTR2	Read/Write	PHTR2 = 1 copies the Remote 2 current temperature to the Remote 2 operating point register if $\overline{\text{THERM}}$ is asserted. The operating point contains the temperature at which $\overline{\text{THERM}}$ is asserted. This allows the system to run as quietly as possible without system performance being affected. PHTR2 = 0 ignores any $\overline{\text{THERM}}$ assertions on the $\overline{\text{THERM}}$ pin. The Remote 2 operating point register reflects its programmed value.
<5>	R1T	Read/Write	R1T = 1 enables dynamic T _{MIN} control on the Remote 1 temperature channel. The chosen T _{MIN} value is dynamically adjusted based on the current temperature, operating point, and high and low limits for this zone. R1T = 0 disables dynamic T _{MIN} control. The T _{MIN} value chosen is not adjusted, and the channel behaves as described in the Automatic Fan Control section.
<6>	LT	Read/Write	LT = 1 enables dynamic T _{MIN} control on the local temperature channel. The chosen T _{MIN} value is dynamically adjusted based on the current temperature, operating point, and high and low limits for this zone. LT = 0 disables dynamic T _{MIN} control. The T _{MIN} value chosen is not adjusted, and the channel behaves as described in the Automatic Fan Control section.
<7>	R2T	Read/Write	R2T = 1 enables dynamic T _{MIN} control on the Remote 2 temperature channel. The chosen T _{MIN} value is dynamically adjusted based on the current temperature, operating point, and high and low limits for this zone. R2T = 0 disables dynamic T _{MIN} control. The T _{MIN} value chosen is not adjusted, and the channel behaves as described in the Automatic Fan Control section.

This register becomes read-only when the Configuration Register 1 lock bit is set to 1. Further attempts to write to this register have no effect.

Table 48. Register 0x37—Dynamic T_{MIN} Control Register 2 (Power-On Default = 0x00)

Bit	Name	R/W	Description		
<2:0>	CYR1	Read/Write	3-Bit Remote 1 Cycle Value. These three bits define the delay time between making subsequent T _{MIN} adjustments in the control loop for the Remote 1 channel, in terms of number of monitoring cycles. The system has associated thermal time constants that need to be found to optimize the response of fans and the control loop.		
			Bits	Decrease Cycle	Increase Cycle
			000	4 Cycles (0.5 s)	8 Cycles (1 s)
			001	8 Cycles (1 s)	16 Cycles (2 s)
			010	16 Cycles (2 s)	32 Cycles (4 s)
			011	32 Cycles (4 s)	64 Cycles (8 s)
			100	64 Cycles (8 s)	128 Cycles (16 s)
			101	128 Cycles (16 s)	256 Cycles (32 s)
			110	256 Cycles (32 s)	512 Cycles (64 s)
			111	512 Cycles (64 s)	1024 Cycles (128 s)
<5:3>	CYL	Read/Write	3-Bit Local Temperature Cycle Value. These three bits define the delay time between making subsequent T _{MIN} adjustments in the control loop for local temperature channel, in terms of number of monitoring cycles. The system has associated thermal time constants that need to be found to optimize the response of fans and the control loop.		
			Bits	Decrease Cycle	Increase Cycle
			000	4 Cycles (0.5 s)	8 Cycles (1 s)
			001	8 Cycles (1 s)	16 Cycles (2 s)
			010	16 Cycles (2 s)	32 Cycles (4 s)
			011	32 Cycles (4 s)	64 Cycles (8 s)
			100	64 Cycles (8 s)	128 Cycles (16 s)
			101	128 Cycles (16 s)	256 Cycles (32 s)
			110	256 Cycles (32 s)	512 Cycles (64 s)
			111	512 Cycles (64 s)	1024 Cycles (128 s)
<7:6>	CYR2	Read/Write	2 LSBs of 3-Bit Remote 2 Cycle Value. The MSB of the 3-bit code resides in Dynamic T _{MIN} Control Register 1 (Reg. 0x36). These three bits define the delay time between making subsequent T _{MIN} adjustments in the control loop for the Remote 2 channel, in terms of number of monitoring cycles. The system has associated thermal time constants that need to be found to optimize the response of fans and the control loop.		
			Bits	Decrease Cycle	Increase Cycle
			000	4 Cycles (0.5 s)	8 Cycles (1 s)
			001	8 Cycles (1 s)	16 Cycles (2 s)
			010	16 Cycles (2 s)	32 Cycles (4 s)
			011	32 Cycles (4 s)	64 Cycles (8 s)
			100	64 Cycles (8 s)	128 Cycles (16 s)
			101	128 Cycles (16 s)	256 Cycles (32 s)
			110	256 Cycles (32 s)	512 Cycles (64 s)
			111	512 Cycles (64 s)	1024 Cycles (128 s)

This register becomes read-only when the Configuration Register 1 lock bit is set to 1. Further attempts to write to this register have no effect.

Table 49. Register 0x40—Configuration Register 1 (Power-On Default = 0x00)

Bit	Name	R/W	Description
<0>	STRT	Read/Write	Logic 1 enables monitoring and PWM control outputs based on the limit settings programmed. Logic 0 disables monitoring and PWM control based on the default power-up limit settings. Note that the limit values programmed are preserved even if a Logic 0 is written to this bit and the default settings are enabled. This bit becomes read-only and cannot be changed once Bit 1 (lock bit) has been written. All limit registers should be programmed by BIOS before setting this bit to 1. (Lockable.)
<1>	LOCK	Write Once	Logic 1 locks all limit values to their current settings. Once this bit is set, all lockable registers become read-only and cannot be modified until the ADT7460 is powered down and powered up again. This prevents rogue programs such as viruses from modifying critical system limit settings. (Lockable.)
<2>	RDY	Read-Only	This bit is set to 1 by the ADT7460 to indicate that the device is fully powered-up and ready to begin systems monitoring.
<3>	FSPD	Read/Write	When set to 1, all fans run at full speed. Power-on default = 0. (This bit cannot be locked.)
<4>	RES	Read-Only	Reserved for future use.
<5>	FSPDIS	Read/Write	Logic 1 disables fan spin-up for two TACH pulses. Instead, the PWM outputs go high for the entire fan spin-up timeout selected.
<6>	TODIS	Read/Write	When set to 1, the SMBus timeout feature is disabled. This allows the ADT7460 to be used with SMBus controllers that cannot handle SMBus timeouts. (Lockable.)
<7>	V _{cc}	Read/Write	When set to 1, the ADT7460 rescales its V _{cc} pin to measure a 5 V supply. When set to 0, the ADT7460 measures V _{cc} as a 3.3 V supply. (Lockable.)

Table 50. Register 0x41—Interrupt Status Register 1 (Power-On Default = 0x00)

Bit	Name	R/W	Description
<0>	2.5V	Read-Only	A 1 indicates that the 2.5 V high or low limit has been exceeded. This bit is cleared on a read of the status register only if the error condition has subsided.
<1>	RES	Read-Only	Reserved for future use.
<2>	V _{cc}	Read-Only	A 1 indicates that the V _{cc} high or low limit has been exceeded. This bit is cleared on a read of the status register only if the error condition has subsided.
<3>	RES	Read-Only	Reserved for future use.
<4>	R1T	Read-Only	A 1 indicates that the Remote 1 low or high temperature limit has been exceeded. This bit is cleared on a read of the status register only if the error condition has subsided.
<5>	LT	Read-Only	A 1 indicates the local low or high temperature limit has been exceeded. This bit is cleared on a read of the Status Register only if the error condition has subsided.
<6>	R2T	Read-Only	A 1 indicates that the Remote 2 low or high temperature limit has been exceeded. This bit is cleared on a read of the status register only if the error condition has subsided.
<7>	OOL	Read-Only	A 1 indicates that an out-of-limit event has been latched in Status Register 2. This bit is a logical OR of all status bits in Status Register 2. Software can test this bit in isolation to determine whether any of the voltage, temperature, or fan speed readings represented by Status Register 2 are out-of-limit. This saves the need to read Status Register 2 every interrupt or polling cycle.

Table 51. Register 0x42—Interrupt Status Register 2 (Power-On Default = 0x00)

Bit	Name	R/W	Description
<0>	RES	Read-Only	Reserved for future use.
<1>	OVT	Read-Only	A 1 indicates that one of the $\overline{\text{THERM}}$ overtemperature limits has been exceeded. This bit is cleared on a read of the status register when the temperature drops below $\overline{\text{THERM}} - T_{\text{HYST}}$.
<2>	FAN1	Read-Only	A 1 indicates that Fan 1 has dropped below minimum speed or has stalled. This bit is NOT set when the PWM1 output is off.
<3>	FAN2	Read-Only	A 1 indicates that Fan 2 has dropped below minimum speed or has stalled. This bit is NOT set when the PWM2 output is off.
<4>	FAN3	Read-Only	A 1 indicates that Fan 3 has dropped below minimum speed or has stalled. This bit is NOT set when the PWM3 output is off.
<5>	F4P	Read-Only	A 1 indicates that Fan 4 has dropped below minimum speed or has stalled. This bit is NOT set when the PWM3 output is off.
		Read-Only	If Pin 9 is configured as the $\overline{\text{THERM}}$ timer input for $\overline{\text{THERM}}$ monitoring, this bit is set when the $\overline{\text{THERM}}$ assertion time exceeds the limit programmed in the $\overline{\text{THERM}}$ Limit Register (Reg. 0x7A).
<6>	D1	Read-Only	A 1 indicates either an open or short circuit on the Thermal Diode 1 inputs.
<7>	D2	Read-Only	A 1 indicates either an open or short circuit on the Thermal Diode 2 inputs.

Table 52. Voltage Limit Registers

Register Address	R/W	Description	Power-On Default
0x44	Read/Write	2.5 V Low Limit	0x00
0x45	Read/Write	2.5 V High Limit	0xFF
0x48	Read/Write	V _{CC} Low Limit	0x00
0x49	Read/Write	V _{CC} High Limit	0xFF

Setting the Configuration Register 1 lock bit has no effect on these registers.

High Limits: An interrupt is generated when a value exceeds its high limit (> comparison).

Low Limits: An interrupt is generated when a value is equal to or below its low limit (\leq comparison).

Table 53. Temperature Limit Registers

Register Address	R/W	Description	Power-On Default
0x4E	Read/Write	Remote 1 temperature low limit	0x81
0x4F	Read/Write	Remote 1 temperature high limit	0x7F
0x50	Read/Write	Local temperature low limit	0x81
0x51	Read/Write	Local temperature high limit	0x7F
0x52	Read/Write	Remote 2 temperature low limit	0x81
0x53	Read/Write	Remote 2 temperature high limit	0x7F

Exceeding any of these temperature limits by 1°C causes the appropriate status bit to be set in the interrupt status register. Setting the Configuration Register 1 lock bit has no effect on these registers.

High Limits: An interrupt is generated when a value exceeds its high limit (> comparison).

Low Limits: An interrupt is generated when a value is equal to or below its low limit (\leq comparison).

Table 54. Fan Tachometer Limit Registers (Power-On Default = 0xFF)

Register Address	R/W	Description
0x54	Read/Write	TACH1 Minimum Low Byte
0x55	Read/Write	TACH1 Minimum High Byte
0x56	Read/Write	TACH2 Minimum Low Byte
0x57	Read/Write	TACH2 Minimum High Byte
0x58	Read/Write	TACH3 Minimum Low Byte
0x59	Read/Write	TACH3 Minimum High Byte
0x5A	Read/Write	TACH4 Minimum Low Byte
0x5B	Read/Write	TACH4 Minimum High Byte

Exceeding any of the TACH limit registers by 1 indicates that the fan is running too slowly or has stalled. The appropriate status bit is set in Interrupt Status Register 2 to indicate the fan failure. Setting the Configuration Register 1 lock bit has no effect on these registers.

Table 55. PWM Configuration Registers (Power-On Default = 0x62)

RegisterAddress	R/W	Description
0x5C	Read/Write	PWM1 Configuration
0x5D	Read/Write	PWM2 Configuration
0x5E	Read/Write	PWM3 Configuration

These registers become read-only when the Configuration Register 1 Lock bit is set to 1. Any subsequent attempts to write to these registers will fail.

Table 56. PWM Configuration Register Bits

Bit	Name	R/W	Description
<2:0>	SPIN	Read/Write	<p>These bits control the start-up timeout for PWMx. The PWM output stays high until two valid TACH rising edges are seen from the fan. If there is not a valid TACH signal during the fan TACH measurement directly after the fan start-up timeout period, the TACH measurement reads 0xFFFF and Status Register 2 reflects the fan fault. If the TACH minimum high and low byte contains 0xFFFF or 0x0000, the Status Register 2 bit is not set, even if the fan has not started.</p> <p>000 = no start-up timeout 001 = 100 ms 010 = 250 ms (default) 011 = 400 ms 100 = 667 ms 101 = 1 s 110 = 2 s 111 = 4 s</p>
<3>	SLOW	Read/Write	SLOW = 1 makes the ramp rates for acoustic enhancement four times longer.
<4>	INV	Read/Write	This bit inverts the PWM output. The default is 0, which corresponds to a logic high output for 100% duty cycle. Setting this bit to 1 inverts the PWM output, so 100% duty cycle corresponds to a logic low output.
<7:5>	BHVR	Read/Write	<p>These bits assign each fan to a particular temperature sensor for localized cooling.</p> <p>000 = Remote 1 temperature controls PWMx (automatic fan control mode). 001 = Local temperature controls PWMx (automatic fan control mode). 010 = Remote 2 temperature controls PWMx (automatic fan control mode). 011 = PWMx runs full speed (default). 100 = PWMx is disabled. 101 = Fastest speed calculated by Local and Remote 2 Temperature Control PWMx. 110 = Fastest speed calculated by all three Temperature Channels Control PWMx. 111 = Manual mode. PWM duty cycle registers (Reg. 0x30–0x32) become writable.</p>

ADT7460

Table 57. TEMP T_{RANGE}/PWM Frequency Registers (Power-On Default 0xC4)

Register Address	R/W	Description
0x5F	Read/Write	Remote 1 T _{RANGE} /PWM1 frequency
0x60	Read/Write	Local Temp T _{RANGE} /PWM2 frequency
0x61	Read/Write	Remote 2 T _{RANGE} /PWM3 frequency

These registers becomes read-only when the Configuration Register 1 lock bit is set to 1. Further attempts to write to this register have no effect.

Table 58. TEMP T_{RANGE}/PWM Frequency Register Bits

Bit	Name	R/W	Description
<2:0>	FREQ	Read/Write	<p>These bits control the PWMx frequency.</p> <p>000 = 11.0 Hz 001 = 14.7 Hz 010 = 22.1 Hz 011 = 29.4 Hz 100 = 35.3 Hz (default) 101 = 44.1 Hz 110 = 58.8 Hz 111 = 88.2 Hz</p>
<3>	THRM	Read/Write	<p>THRM = 1 causes the <u>THERM</u> pin (Pin 9) to assert low as an output when this temperature channel's <u>THERM</u> limit is exceeded by 0.25°C. The <u>THERM</u> pin remains asserted until the temperature is equal to or below the <u>THERM</u> limit. The minimum time that <u>THERM</u> asserts for is one monitoring cycle. This allows clock modulation of devices that incorporate this feature.</p> <p>THRM = 0 makes the <u>THERM</u> pin act as an input only, for example, for Pentium 4 <u>PROCHOT</u> monitoring, when Pin 9 is configured as <u>THERM</u>.</p>
<7:4>	RANGE	Read/Write	<p>These bits determine the PWM duty cycle vs. temperature slope for automatic fan control.</p> <p>0000 = 2°C 0001 = 2.5°C 0010 = 3.33°C 0011 = 4°C 0100 = 5°C 0101 = 6.67°C 0110 = 8°C 0111 = 10°C 1000 = 13.33°C 1001 = 16°C 1010 = 20°C 1011 = 26.67°C 1100 = 32°C (Default) 1101 = 40°C 1110 = 53.33°C 1111 = 80°C</p>

Table 59. Register 0x62—Enhance Acoustics Register 1 (Power-On Default = 0x00)

Bit	Name	R/W	Description																		
<2:0>	ACOU	Read/Write	<p>These bits select the ramp rate applied to the PWM1 output. Instead of PWM1 jumping instantaneously to its newly calculated speed, PWM1 ramps gracefully at the rate determined by these bits. This feature enhances the acoustics of the fan being driven by the PWM1 output.</p> <table border="0"> <thead> <tr> <th>Time Slot Increase</th> <th>Time for 33% to 100%</th> </tr> </thead> <tbody> <tr> <td>000 = 1</td> <td>35 s</td> </tr> <tr> <td>001 = 2</td> <td>17.6 s</td> </tr> <tr> <td>010 = 3</td> <td>18 s</td> </tr> <tr> <td>011 = 5</td> <td>7 s</td> </tr> <tr> <td>100 = 8</td> <td>4.4 s</td> </tr> <tr> <td>101 = 12</td> <td>3 s</td> </tr> <tr> <td>110 = 24</td> <td>1.6 s</td> </tr> <tr> <td>111 = 48</td> <td>0.8 s</td> </tr> </tbody> </table>	Time Slot Increase	Time for 33% to 100%	000 = 1	35 s	001 = 2	17.6 s	010 = 3	18 s	011 = 5	7 s	100 = 8	4.4 s	101 = 12	3 s	110 = 24	1.6 s	111 = 48	0.8 s
Time Slot Increase	Time for 33% to 100%																				
000 = 1	35 s																				
001 = 2	17.6 s																				
010 = 3	18 s																				
011 = 5	7 s																				
100 = 8	4.4 s																				
101 = 12	3 s																				
110 = 24	1.6 s																				
111 = 48	0.8 s																				
<3>	EN1	Read/Write	When this bit is 1, acoustic enhancement is enabled on PWM1 output.																		
<4>	SYNC	Read/Write	<p>SYNC = 1 synchronizes fan speed measurements on TACH2, TACH3, and TACH4 to PWM3. This allows up to three fans to be driven from PWM3 output and their speeds to be measured.</p> <p>SYNC = 0, only TACH3 and TACH4 are synchronized to PWM3 output.</p>																		
<5>	MIN1	Read/Write	<p>When the ADT7460 is in automatic fan control mode, this bit defines whether PWM1 is off (0% duty cycle) or at PWM1 minimum duty cycle when the controlling temperature is below its T_{MIN} – Hysteresis value.</p> <p>0 = 0% Duty Cycle below T_{MIN} – Hysteresis</p> <p>1 = PWM1 Minimum Duty Cycle below T_{MIN} – Hysteresis</p>																		
<6>	MIN2	Read/Write	<p>When the ADT7460 is in automatic fan speed control mode, this bit defines whether PWM2 is off (0% duty cycle) or at PWM2 minimum duty cycle when the controlling temperature is below its T_{MIN} – Hysteresis value.</p> <p>0 = 0% Duty Cycle below T_{MIN} – Hysteresis</p> <p>1 = PWM2 Minimum Duty Cycle below T_{MIN} – Hysteresis</p>																		
<7>	MIN3	Read/Write	<p>When the ADT7460 is in automatic fan speed control mode, this bit defines whether PWM3 is off (0% duty cycle) or at PWM3 minimum duty cycle when the controlling temperature is below its T_{MIN} – Hysteresis value.</p> <p>0 = 0% Duty Cycle below T_{MIN} – Hysteresis</p> <p>1 = PWM3 Minimum Duty Cycle below T_{MIN} – Hysteresis</p>																		

This register becomes read-only when the Configuration Register 1 lock bit is set to 1. Further attempts to write to this register have no effect.

ADT7460

Table 60. Register 0x63—Enhance Acoustics Register 2 (Power-On Default = 0x00)

Bit	Name	R/W	Description
<2:0>	ACOU3	Read/Write	<p>These bits select the ramp rate applied to the PWM3 output. Instead of PWM3 jumping instantaneously to its newly calculated speed, PWM3 ramps gracefully at the rate determined by these bits. This effect enhances the acoustics of the fan being driven by the PWM3 output.</p> <p>Time Slot Increase Time for 33% to 100%</p> <p>000 = 1 35 s</p> <p>001 = 2 17.6 s</p> <p>010 = 3 11.8 s</p> <p>011 = 5 7 s</p> <p>100 = 8 4.4 s</p> <p>101 = 12 3 s</p> <p>110 = 24 1.6 s</p> <p>111 = 48 0.8 s</p>
<3>	EN3	Read/Write	When this bit is 1, acoustic enhancement is enabled on PWM3 output.
<6:4>	ACOU2	Read/Write	<p>These bits select the ramp rate applied to the PWM2 output. Instead of PWM2 jumping instantaneously to its newly calculated speed, PWM2 ramps gracefully at the rate determined by these bits. This effect enhances the acoustics of the fans being driven by the PWM2 output.</p> <p>Time Slot Increase Time for 33% to 100%</p> <p>000 = 1 35 s</p> <p>001 = 2 17.6 s</p> <p>010 = 3 11.8 s</p> <p>011 = 5 7 s</p> <p>100 = 8 4.4 s</p> <p>101 = 12 3 s</p> <p>110 = 24 1.6 s</p> <p>111 = 48 0.8 s</p>
<7>	EN2	Read/Write	When this bit is 1, acoustic enhancement is enabled on PWM2 output.

This register becomes read-only when the Configuration Register 1 lock bit is set to 1. Further attempts to write to this register have no effect.

Table 61. PWM Min Duty Cycle Registers

Register Address	R/W	Description	Power-On Default
0x64	Read/Write	PWM1 Min Duty Cycle	0x80 (50% duty cycle)
0x65	Read/Write	PWM2 Min Duty Cycle	0x80 (50% duty cycle)
0x66	Read/Write	PWM3 Min Duty Cycle	0x80 (50% duty cycle)

These registers become read-only when the ADT7460 is in automatic fan control mode.

Table 62. PWM Min Duty Cycle Register Bits

Bit	Name	Read/Write	Description
<7:0>	PWM Duty Cycle	Read/Write	<p>These bits define the PWM_{MIN} duty cycle for PWMx.</p> <p>0x00 = 0% Duty Cycle (Fan Off)</p> <p>0x40 = 25% Duty Cycle</p> <p>0x80 = 50% Duty Cycle</p> <p>0xFF = 100% Duty Cycle (Fan Full Speed)</p>

Table 63. T_{MIN} Registers

Register Address	R/W	Description	Power-On Default
0x67	Read/Write	Remote 1 Temperature T _{MIN}	0x5A (90°C)
0x68	Read/Write	Local Temperature T _{MIN}	0x5A (90°C)
0x69	Read/Write	Remote 2 Temperature T _{MIN}	0x5A (90°C)

These are the T_{MIN} registers for each temperature channel. When the temperature measured exceeds T_{MIN}, the appropriate fan runs at minimum speed and increase with temperature according to T_{RANGE}.

These registers become read-only when the Configuration Register 1 lock bit is set. Further attempts to write to these registers have no effect.

Table 64. THERM Limit Registers

Register Address	R/W	Description	Power-On Default
0x6A	Read/Write	Remote 1 THERM Limit	0x64 (100°C)
0x6B	Read/Write	Local THERM Limit	0x64 (100°C)
0x6C	Read/Write	Remote 2 THERM Limit	0x64 (100°C)

If any temperature measured exceeds its THERM limit, all PWM outputs drive their fans at 100% duty cycle. This is a fail-safe mechanism incorporated to cool the system in the event of a critical overtemperature. It also ensures some level of cooling in the event that software or hardware locks up. If set to 0x80, this feature is disabled. The PWM output remains at 100% until the temperature drops below THERM Limit – Hysteresis. If the THERM pin is programmed as an output, exceeding these limits by 0.25°C can cause the THERM pin to assert low as an output.

These registers become read-only when the Configuration Register 1 Lock bit is set to 1. Further attempts to write to these registers have no effect.

Table 65. Temperature Hysteresis Registers

Register Address	R/W	Description	Power-On Default
0x6D	Read/Write	Remote 1 Local Temperature Hysteresis	0x44
0x6E	Read/Write	Remote 2 Temperature Hysteresis	0x40

Each 4-bit value controls the amount of temperature hysteresis applied to a particular temperature channel. Once the temperature for that channel falls below its T_{MIN} value, the fan remains running at PWM_{MIN} duty cycle until the temperature = T_{MIN} – Hysteresis. Up to 15°C of hysteresis may be assigned to any temperature channel. The hysteresis value chosen also applies to that temperature channel if its THERM limit is exceeded. The PWM output being controlled goes to 100% if the THERM limit is exceeded and remains at 100% until the temperature drops below THERM – Hysteresis. For acoustic reasons, it is recommended that the hysteresis value not be programmed less than 4°C. Setting the hysteresis value lower than 4°C causes the fan to switch on and off regularly when the temperature is close to T_{MIN}. These registers become read-only when the Configuration Register 1 lock bit is set to 1. Further attempts to write to these registers have no effect.

Table 66. XNOR Tree Test Enable Register (Power-On Default = 0x00)

Register Address	R/W	Description									
0x6F	Read/Write	<p>XNOR Tree Test Enable</p> <table border="1"> <thead> <tr> <th>Bit</th> <th>Mnemonic</th> <th>Description</th> </tr> </thead> <tbody> <tr> <td><0></td> <td>XEN</td> <td>If the XEN bit is set to 1, the device enters the XNOR tree test mode. Clearing the bit removes the device from the XNOR test mode.</td> </tr> <tr> <td><7:1></td> <td>RES</td> <td>Unused. Do not write to these bits.</td> </tr> </tbody> </table>	Bit	Mnemonic	Description	<0>	XEN	If the XEN bit is set to 1, the device enters the XNOR tree test mode. Clearing the bit removes the device from the XNOR test mode.	<7:1>	RES	Unused. Do not write to these bits.
Bit	Mnemonic	Description									
<0>	XEN	If the XEN bit is set to 1, the device enters the XNOR tree test mode. Clearing the bit removes the device from the XNOR test mode.									
<7:1>	RES	Unused. Do not write to these bits.									

This register becomes read-only when the Configuration Register 1 lock bit is set to 1. Further attempts to write to this register have no effect.

ADT7460

Table 67. Remote 1 Temperature Offset Register (Power-On Default = 0x00)

Register Address	R/W	Description
0x70	Read/Write	Remote 1 Temperature Offset
<7:0>	Read/Write	Allows a twos complement offset value to be automatically added to or subtracted from the Remote 1 temperature reading. This is to compensate for any inherent system offsets such as PCB trace resistance. LSB value = 0.25°C.

This register becomes read-only when the Configuration Register 1 lock bit is set to 1. Further attempts to write to this register have no effect.

Table 68. Local Temperature Offset Register (Power-On Default = 0x00)

Register Address	R/W	Description
0x71	Read/Write	Local Temperature Offset
<7:0>	Read/Write	Allows a twos complement offset value to be automatically added to or subtracted from the local temperature reading. LSB value = 0.25°C.

This register becomes read-only when the Configuration Register 1 lock bit is set to 1. Further attempts to write to this register have no effect.

Table 69. Remote 2 Temperature Offset Register (Power-On Default = 0x00)

Register Address	R/W	Description
0x72	Read/Write	Remote 2 Temperature Offset
<7:0>	Read/Write	Allows a twos complement offset value to be automatically added to or subtracted from the Remote 2 temperature reading. This is to compensate for any inherent system offsets such as PCB trace resistance. LSB value = 0.25°C.

This register becomes read-only when the Configuration Register 1 lock bit is set to 1. Further attempts to write to this register have no effect.

Table 70. Register 0x73—Configuration Register 2 (Power-On Default = 0x00)

Bit	Name	R/W	Description
0	AIN1	Read/Write	AIN1 = 0, Speed of 3-wire fans measured using the TACH output from the fan. AIN1 = 1, Pin 6 is reconfigured to measure the speed of 2-wire fans using an external sensing resistor and coupling capacitor. AIN voltage threshold is set via Configuration Register 4 (Reg. 0x7D).
1	AIN2	Read/Write	AIN2 = 0, Speed of 3-wire fans measured using the TACH output from the fan. AIN2 = 1, Pin 7 is reconfigured to measure the speed of 2-wire fans using an external sensing resistor and coupling capacitor. AIN voltage threshold is set via Configuration Register 4 (Reg. 0x7D).
2	AIN3	Read/Write	AIN3 = 0, Speed of 3-wire fans measured using the TACH output from the fan. AIN3 = 1, Pin 4 is reconfigured to measure the speed of 2-wire fans using an external sensing resistor and coupling capacitor. AIN voltage threshold is set via Configuration Register 4 (Reg. 0x7D).
3	AIN4	Read/Write	AIN4 = 0, Speed of 3-wire fans measured using the TACH output from the fan. AIN4 = 1, Pin 9 is reconfigured to measure the speed of 2-wire fans using an external sensing resistor and coupling capacitor. AIN voltage threshold is set via Configuration Register 4 (Reg. 0x7D).
4	AVG	Read/Write	AVG = 1, Averaging on the temperature and voltage measurements is turned off. This allows measurements on each channel to be made much faster.
5	ATTN	Read/Write	ATTN = 1, the ADT7460 removes the attenuators from the 2.5 V input. The input can be used for other functions such as connecting up external sensors.
6	CONV	Read/Write	CONV = 1, the ADT7460 is put into a single-channel ADC conversion mode. In this mode, the ADT7460 can be made to read continuously from one input only, for example, Remote 1 temperature. It is also possible to start ADC conversions using an external clock on Pin 6 by setting Bit 2 of Test Register 2 (Reg. 0x7F). This mode could be useful if, for example, users wanted to characterize/profile CPU temperature quickly. The appropriate ADC channel is selected by writing to Bits <7:5> of TACH1 min high byte register (Reg. 0x55). Bits <7:5> Reg. 0x55 Channel Selected 000 2.5 V 010 V _{CC} (3.3 V) 101 Remote 1 Temp 110 Local Temp 111 Remote 2 Temp
7	SHDN	Read/Write	SHDN = 1, ADT7460 goes into shutdown mode. All PWM outputs assert low (or high depending, on state of INV bit) to switch off all fans. The PWM current duty cycle registers read 0x00 to indicate that the fans are not being driven.

This register becomes read-only when the Configuration Register 1 lock bit is set to 1. Further attempts to write to this register have no effect.

Table 71. Register 0x74—Interrupt Mask Register 1 (Power-On Default <7:0> = 0x00)

Bit	Name	R/W	Description
0	2.5V	Read/Write	A 1 masks $\overline{\text{SMBALERT}}$ for out-of-limit conditions on the 2.5 V channel.
1	RES	Read/Write	Reserved for future use.
2	V _{CC}	Read/Write	A 1 masks $\overline{\text{SMBALERT}}$ for out-of-limit conditions on the V _{CC} channel.
3	RES	Read/Write	Reserved for future use.
4	R1T	Read/Write	A 1 masks $\overline{\text{SMBALERT}}$ for out-of-limit conditions on the Remote 1 temperature channel.
5	LT	Read/Write	A 1 masks $\overline{\text{SMBALERT}}$ for out-of-limit conditions on the Local temperature channel.
6	R2T	Read/Write	A 1 masks $\overline{\text{SMBALERT}}$ for out-of-limit conditions on the Remote 2 temperature channel.
7	OOL	Read/Write	A 1 masks $\overline{\text{SMBALERT}}$ for any out-of-limit condition in Status Register 2.

ADT7460

Table 72. Register 0x75—Interrupt Mask Register 2 (Power-On Default = 0x00)

Bit	Name	R/W	Description
0	RES	Read/Write	Reserved for future use.
1	OVT	Read-Only	A 1 masks $\overline{\text{SMBALERT}}$ for overtemperature $\overline{\text{THERM}}$ conditions.
2	FAN1	Read/Write	A 1 masks $\overline{\text{SMBALERT}}$ for a Fan 1 fault.
3	FAN2	Read/Write	A 1 masks $\overline{\text{SMBALERT}}$ for a Fan 2 fault.
4	FAN3	Read/Write	A 1 masks $\overline{\text{SMBALERT}}$ for a Fan 3 fault.
5	F4P	Read/Write	A 1 masks $\overline{\text{SMBALERT}}$ for a Fan 4 fault. If the TACH4 pin is being used as the $\overline{\text{THERM}}$ input, this bit masks $\overline{\text{SMBALERT}}$ for a $\overline{\text{THERM}}$ timer event.
6	D1	Read/Write	A 1 masks $\overline{\text{SMBALERT}}$ for a diode open or short on Remote 1 channel.
7	D2	Read/Write	A 1 masks $\overline{\text{SMBALERT}}$ for a diode open or short on Remote 2 channel.

Table 73. Register 0x76—Extended Resolution Register 1

Bit	Name	R/W	Description
<1:0>	2.5V	Read-Only	2.5 V LSBs. Holds the 2 LSBs of the 10-bit 2.5 V measurement.
<3:2>	RES	Read/Write	Reserved for future use.
<5:4>	V _{CC}	Read-Only	V _{CC} LSBs. Holds the 2 LSBs of the 10-bit V _{CC} measurement.
<7:6>	RES	Read/Write	Reserved for future use.

If this register is read, this register and the registers holding the MSB of each reading are frozen until read.

Table 74. Register 0x77—Extended Resolution Register 2

Bit	Name	R/W	Description
<1:0>	RES	Read/Write	Reserved for future use.
<3:2>	TDM1	Read-Only	Remote 1 Temperature LSBs. Holds the 2 LSBs of the 10-bit Remote 1 temperature measurement.
<5:4>	LTMP	Read-Only	Local Temperature LSBs. Holds the 2 LSBs of the 10-bit local temperature measurement.
<7:6>	TDM2	Read-Only	Remote 2 Temperature LSBs. Holds the 2 LSBs of the 10-bit Remote 2 temperature measurement.

If this register is read, this register and the registers holding the MSB of each reading are frozen until read.

Table 75. Register 0x78—Configuration Register 3 (Power-On Default = 0x00)

Bit	Name	R/W	Description
<0>	ALERT	Read/Write	ALERT = 1, Pin 5 (PWM2/ $\overline{\text{SMBALERT}}$) is configured as an $\overline{\text{SMBALERT}}$ interrupt output to indicate out-of-limit error conditions.
<1>	$\overline{\text{THERM}}$ ENABLE	Read/Write	$\overline{\text{THERM}}$ ENABLE = 1 enables $\overline{\text{THERM}}$ monitoring functionality on Pin 9 when it is configured as $\overline{\text{THERM}}$. When $\overline{\text{THERM}}$ is asserted, fans can be run at full speed (if the BOOST bit is set), or a timer can be triggered to time how long $\overline{\text{THERM}}$ has been asserted for.
<2>	BOOST	Read/Write	BOOST = 1, assertion of $\overline{\text{THERM}}$ causes all fans to run at 100% duty cycle for fail-safe cooling.
<3>	FAST	Read/Write	FAST = 1 enables fast TACH measurements on all channels. This increases the TACH measurement rate from once per second, to once every 250 ms (4x).
<4>	DC1	Read/Write	DC1 = 1 enables TACH measurements to be continuously made on TACH1.
<5>	DC2	Read/Write	DC2 = 2 enables TACH measurements to be continuously made on TACH2.
<6>	DC3	Read/Write	DC3 = 1 enables TACH measurements to be continuously made on TACH3.
<7>	DC4	Read/Write	DC4 = 1 enables TACH measurements to be continuously made on TACH4.

This register becomes read-only when the Configuration Register 1 lock bit is set to 1. Further attempts to write to this register have no effect.

Table 76. Register 0x79— $\overline{\text{THERM}}$ Status Register (Power-On Default = 0x00)

Bit	Name	R/W	Description
<7:1>	TMR	Read-Only	Times how long $\overline{\text{THERM}}$ input is asserted. These seven bits read 0 until the $\overline{\text{THERM}}$ assertion time exceeds 45.52 ms.
<0>	ASRT/TMRO	Read-Only	Is set high on the assertion of the $\overline{\text{THERM}}$ input. Cleared on read. If the $\overline{\text{THERM}}$ assertion time exceeds 45.52 ms, this bit is set and becomes the LSB of the 8-bit TMR reading. This allows $\overline{\text{THERM}}$ assertion times from 45.52 ms to 5.82 s to be reported back with a resolution of 22.76 ms.

Table 77. Register 0x7A— $\overline{\text{THERM}}$ Limit Register (Power-On Default = 0x00)

Bit	Name	R/W	Description
<7:0>	LIMIT	Read/Write	Sets maximum $\overline{\text{THERM}}$ assertion length allowed before an interrupt is generated. This is an 8-bit limit with a resolution of 22.76 ms allowing $\overline{\text{THERM}}$ assertion limits of 45.52 ms to 5.82 s to be programmed. If the $\overline{\text{THERM}}$ assertion time exceeds this limit, Bit 5 (F4P) of Interrupt Status Register 2 (Reg. 0x42) is set. If the limit value is 0x00, an interrupt is generated immediately upon the assertion of the $\overline{\text{THERM}}$ input.

Table 78. Register 0x7B—Fan Pulses per Revolution Register (Power-On Default = 0x55)

Bit	Name	R/W	Description
<1:0>	FAN1	Read/Write	Sets number of pulses to be counted when measuring Fan1 speed. Can be used to determine fan's pulses per revolution for unknown fan type. Pulses Counted 00 = 1 01 = 2 (Default) 10 = 3 11 = 4
<3:2>	FAN2	Read/Write	Sets number of pulses to be counted when measuring FAN2 speed. Can be used to determine fan's pulses per revolution for unknown fan type. Pulses Counted 00 = 1 01 = 2 (Default) 10 = 3 11 = 4
<5:4>	FAN3	Read/Write	Sets number of pulses to be counted when measuring FAN3 speed. Can be used to determine fan's pulses per revolution for unknown fan type. Pulses Counted 00 = 1 01 = 2 (Default) 10 = 3 11 = 4
<7:6>	FAN4	Read/Write	Sets number of pulses to be counted when measuring FAN4 speed. Can be used to determine fan's pulses per revolution for unknown fan type. Pulses Counted 00 = 1 01 = 2 (Default) 10 = 3 11 = 4

ADT7460

Table 79. Register 0x7D—Configuration Register 4 (Power-On Default = 0x00)

Bit	Name	R/W	Description
<0>	AL2.5V	Read/Write	AL2.5V = 1, Pin 14 (2.5V/SMBALERT) is configured as an SMBALERT interrupt output to indicate out-of-limit error conditions. AL2.5V = 0, Pin 14 (2.5V/SMBALERT) is configured as a 2.5 V measurement input.
<1>	RES	Read-Only	Reserved for future use.
<3:2>	AINL	Read/Write	These two bits define the input threshold for 2-wire fan speed measurements: 00 = ±20 mV 01 = ±40 mV 10 = ±80 mV 11 = ±130 mV
<7:4>	RES		Reserved for future use.

This register becomes read-only when the Configuration Register 1 lock bit is set to 1. Further attempts to write to this register have no effect.

Table 80. Register 0x7E—Manufacturer’s Test Register 1 (Power On-Default = 0x00)

Bit	Name	Read/Write	Description
<7:0>	RES	Read-Only	Manufacturer’s Test Register. These bits are reserved for manufacturer’s test purposes and should NOT be written to under normal operation.

Table 81. Register 0x7F—Manufacturer’s Test Register 2 (Power-On Default = 0x00)

Bit	Name	Read/Write	Description
<7:0>	RES	Read-Only	Manufacturer’s Test Register. These bits are reserved for manufacturer’s test purposes and should NOT be written to under normal operation.

ADT7460

NOTES

Looking for pricing, stock, or lifecycle information?

Click below to explore more details on WIN SOURCE:

- ⊖ [View ADT7460ARQ-REEL on WIN SOURCE](#)
- ⊖ [ON Semiconductor](#) Information

Optimize Your Supply Chain with WIN SOURCE Solutions

- ✓ Global Sourcing Solution
- ✓ Obsolete Management
- ✓ Cost Control Management
- ✓ Shortage Management
- ✓ Alternative Solution
- ✓ Excess Inventory Management