



**THE DATASHEET OF
ADSP-BF531SBBCZ400**



ADSP-BF531/ADSP-BF532/ADSP-BF533

FEATURES

- Up to 600 MHz high performance Blackfin processor
 - Two 16-bit MACs, two 40-bit ALUs, four 8-bit video ALUs, 40-bit shifter
 - RISC-like register and instruction model for ease of programming and compiler-friendly support
 - Advanced debug, trace, and performance monitoring
 - Wide range of operating voltages (see [Operating Conditions on Page 20](#))
 - Qualified for Automotive Applications (see [Automotive Products on Page 62](#))
 - Programmable on-chip voltage regulator
 - 160-ball CSP_BGA, 169-ball PBGA, and 176-lead LQFP packages
- ### MEMORY
- Up to 148K bytes of on-chip memory (see [Table 1 on Page 3](#))
 - Memory management unit providing memory protection
 - External memory controller with glueless support for SDRAM, SRAM, flash, and ROM
 - Flexible memory booting options from SPI and external memory

PERIPHERALS

- Parallel peripheral interface PPI, supporting ITU-R 656 video data formats
- 2 dual-channel, full duplex synchronous serial ports, supporting eight stereo I²S channels
- 2 memory-to-memory DMAs
- 8 peripheral DMAs
- SPI-compatible port
- Three 32-bit timer/counters with PWM support
- Real-time clock and watchdog timer
- 32-bit core timer
- Up to 16 general-purpose I/O pins (GPIO)
- UART with support for IrDA
- Event handler
- Debug/JTAG interface
- On-chip PLL capable of frequency multiplication

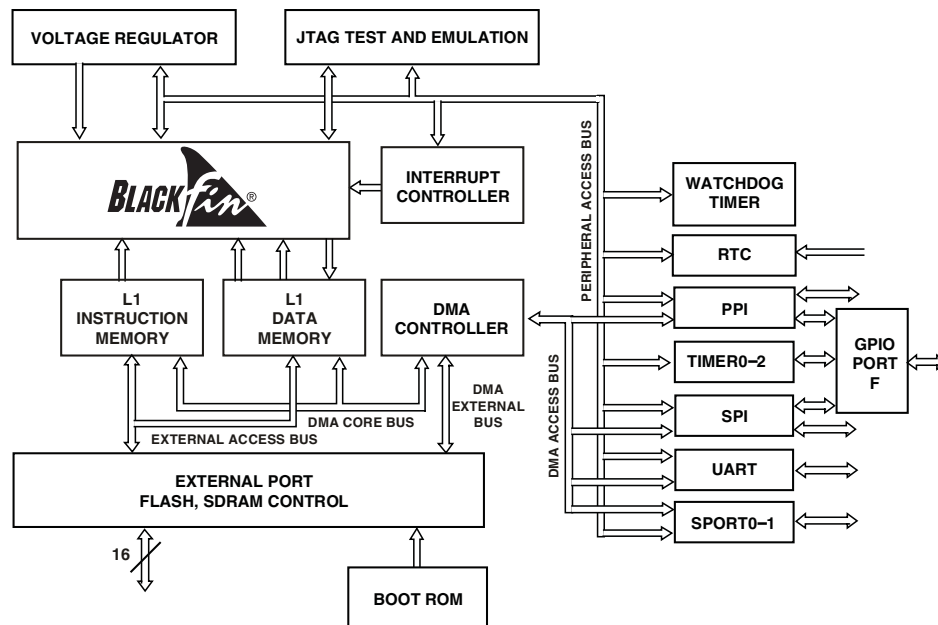

Figure 1. Functional Block Diagram

Blackfin and the Blackfin logo are registered trademarks of Analog Devices, Inc.

Rev. I **Document Feedback**
 Information furnished by Analog Devices is believed to be accurate and reliable. However, no responsibility is assumed by Analog Devices for its use, nor for any infringements of patents or other rights of third parties that may result from its use. Specifications subject to change without notice. No license is granted by implication or otherwise under any patent or patent rights of Analog Devices. Trademarks and registered trademarks are the property of their respective owners.

ADSP-BF531/ADSP-BF532/ADSP-BF533

TABLE OF CONTENTS

Features	1	Development Tools	15
Memory	1	Additional Information	16
Peripherals	1	Related Signal Chains	16
General Description	3	Pin Descriptions	17
Portable Low Power Architecture	3	Specifications	20
System Integration	3	Operating Conditions	20
Processor Peripherals	3	Electrical Characteristics	22
Blackfin Processor Core	4	Absolute Maximum Ratings	25
Memory Architecture	4	ESD Sensitivity	25
DMA Controllers	8	Package Information	26
Real-Time Clock	8	Timing Specifications	27
Watchdog Timer	9	Output Drive Currents	43
Timers	9	Test Conditions	45
Serial Ports (SPORTs)	9	Thermal Characteristics	49
Serial Peripheral Interface (SPI) Port	10	160-Ball CSP_BGA Ball Assignment	50
UART Port	10	169-Ball PBGA Ball Assignment	53
General-Purpose I/O Port F	10	176-Lead LQFP Pinout	56
Parallel Peripheral Interface	11	Outline Dimensions	58
Dynamic Power Management	11	Surface-Mount Design	61
Voltage Regulation	13	Automotive Products	62
Clock Signals	13	Ordering Guide	63
Bootling Modes	14		
Instruction Set Description	15		

REVISION HISTORY

8/13— Rev. H to Rev. I

Updated Development Tools	15
Corrected Conditions value of the V_{IL} specification in Operating Conditions	20
Added notes to Table 30 in Serial Ports—Enable and Three-State	36
Added Timer Clock Timing	41
Revised Timer Cycle Timing	41
Updated Ordering Guide	63

GENERAL DESCRIPTION

The ADSP-BF531/ADSP-BF532/ADSP-BF533 processors are members of the Blackfin® family of products, incorporating the Analog Devices, Inc./Intel Micro Signal Architecture (MSA). Blackfin processors combine a dual-MAC state-of-the-art signal processing engine, the advantages of a clean, orthogonal RISC-like microprocessor instruction set, and single instruction, multiple data (SIMD) multimedia capabilities into a single instruction set architecture.

The ADSP-BF531/ADSP-BF532/ADSP-BF533 processors are completely code and pin-compatible, differing only with respect to their performance and on-chip memory. Specific performance and memory configurations are shown in [Table 1](#).

Table 1. Processor Comparison

	ADSP-BF531	ADSP-BF532	ADSP-BF533	
Features				
SPORTs	2	2	2	
UART	1	1	1	
SPI	1	1	1	
GP Timers	3	3	3	
Watchdog Timers	1	1	1	
RTC	1	1	1	
Parallel Peripheral Interface	1	1	1	
GPIOs	16	16	16	
Memory Configuration	L1 Instruction SRAM/Cache	16K bytes	16K bytes	16K bytes
	L1 Instruction SRAM	16K bytes	32K bytes	64K bytes
	L1 Data SRAM/Cache	16K bytes	32K bytes	32K bytes
	L1 Data SRAM			32K bytes
	L1 Scratchpad	4K bytes	4K bytes	4K bytes
	L3 Boot ROM	1K bytes	1K bytes	1K bytes
Maximum Speed Grade	400 MHz	400 MHz	600 MHz	
Package Options:				
CSP_BGA	160-Ball	160-Ball	160-Ball	
Plastic BGA	169-Ball	169-Ball	169-Ball	
LQFP	176-Lead	176-Lead	176-Lead	

By integrating a rich set of industry-leading system peripherals and memory, Blackfin processors are the platform of choice for next generation applications that require RISC-like programmability, multimedia support, and leading-edge signal processing in one integrated package.

PORTABLE LOW POWER ARCHITECTURE

Blackfin processors provide world-class power management and performance. Blackfin processors are designed in a low power and low voltage design methodology and feature dynamic power management—the ability to vary both the voltage and frequency of operation to significantly lower overall power consumption. Varying the voltage and frequency can result in a substantial reduction in power consumption, compared with just varying the frequency of operation. This translates into longer battery life for portable appliances.

SYSTEM INTEGRATION

The ADSP-BF531/ADSP-BF532/ADSP-BF533 processors are highly integrated system-on-a-chip solutions for the next generation of digital communication and consumer multimedia applications. By combining industry-standard interfaces with a high performance signal processing core, users can develop cost-effective solutions quickly without the need for costly external components. The system peripherals include a UART port, an SPI port, two serial ports (SPORTs), four general-purpose timers (three with PWM capability), a real-time clock, a watchdog timer, and a parallel peripheral interface.

PROCESSOR PERIPHERALS

The ADSP-BF531/ADSP-BF532/ADSP-BF533 processors contain a rich set of peripherals connected to the core via several high bandwidth buses, providing flexibility in system configuration as well as excellent overall system performance (see the functional block diagram in [Figure 1 on Page 1](#)). The general-purpose peripherals include functions such as UART, timers with PWM (pulse-width modulation) and pulse measurement capability, general-purpose I/O pins, a real-time clock, and a watchdog timer. This set of functions satisfies a wide variety of typical system support needs and is augmented by the system expansion capabilities of the part. In addition to these general-purpose peripherals, the processors contain high speed serial and parallel ports for interfacing to a variety of audio, video, and modem codec functions; an interrupt controller for flexible management of interrupts from the on-chip peripherals or external sources; and power management control functions to tailor the performance and power characteristics of the processor and system to many application scenarios.

All of the peripherals, except for general-purpose I/O, real-time clock, and timers, are supported by a flexible DMA structure. There is also a separate memory DMA channel dedicated to data transfers between the processor's various memory spaces, including external SDRAM and asynchronous memory. Multiple on-chip buses running at up to 133 MHz provide enough bandwidth to keep the processor core running along with activity on all of the on-chip and external peripherals.

The processors include an on-chip voltage regulator in support of the processor's dynamic power management capability. The voltage regulator provides a range of core voltage levels from V_{DDEXT} . The voltage regulator can be bypassed at the user's discretion.

ADSP-BF531/ADSP-BF532/ADSP-BF533

BLACKFIN PROCESSOR CORE

As shown in [Figure 2 on Page 5](#), the Blackfin processor core contains two 16-bit multipliers, two 40-bit accumulators, two 40-bit ALUs, four video ALUs, and a 40-bit shifter. The computation units process 8-bit, 16-bit, or 32-bit data from the register file.

The compute register file contains eight 32-bit registers. When performing compute operations on 16-bit operand data, the register file operates as 16 independent 16-bit registers. All operands for compute operations come from the multiported register file and instruction constant fields.

Each MAC can perform a 16-bit by 16-bit multiply in each cycle, accumulating the results into the 40-bit accumulators. Signed and unsigned formats, rounding, and saturation are supported.

The ALUs perform a traditional set of arithmetic and logical operations on 16-bit or 32-bit data. In addition, many special instructions are included to accelerate various signal processing tasks. These include bit operations such as field extract and population count, modulo 2^{32} multiply, divide primitives, saturation and rounding, and sign/exponent detection. The set of video instructions includes byte alignment and packing operations, 16-bit and 8-bit adds with clipping, 8-bit average operations, and 8-bit subtract/absolute value/accumulate (SAA) operations. Also provided are the compare/select and vector search instructions.

For certain instructions, two 16-bit ALU operations can be performed simultaneously on register pairs (a 16-bit high half and 16-bit low half of a compute register). Quad 16-bit operations are possible using the second ALU.

The 40-bit shifter can perform shifts and rotates and is used to support normalization, field extract, and field deposit instructions.

The program sequencer controls the flow of instruction execution, including instruction alignment and decoding. For program flow control, the sequencer supports PC relative and indirect conditional jumps (with static branch prediction), and subroutine calls. Hardware is provided to support zero-overhead looping. The architecture is fully interlocked, meaning that the programmer need not manage the pipeline when executing instructions with data dependencies.

The address arithmetic unit provides two addresses for simultaneous dual fetches from memory. It contains a multiported register file consisting of four sets of 32-bit index, modify, length, and base registers (for circular buffering), and eight additional 32-bit pointer registers (for C-style indexed stack manipulation).

Blackfin processors support a modified Harvard architecture in combination with a hierarchical memory structure. Level 1 (L1) memories are those that typically operate at the full processor speed with little or no latency. At the L1 level, the instruction memory holds instructions only. The two data memories hold data, and a dedicated scratchpad data memory stores stack and local variable information.

In addition, multiple L1 memory blocks are provided, offering a configurable mix of SRAM and cache. The memory management unit (MMU) provides memory protection for individual tasks that may be operating on the core and can protect system registers from unintended access.

The architecture provides three modes of operation: user mode, supervisor mode, and emulation mode. User mode has restricted access to certain system resources, thus providing a protected software environment, while supervisor mode has unrestricted access to the system and core resources.

The Blackfin processor instruction set has been optimized so that 16-bit opcodes represent the most frequently used instructions, resulting in excellent compiled code density. Complex DSP instructions are encoded into 32-bit opcodes, representing fully featured multifunction instructions. Blackfin processors support a limited multi-issue capability, where a 32-bit instruction can be issued in parallel with two 16-bit instructions, allowing the programmer to use many of the core resources in a single instruction cycle.

The Blackfin processor assembly language uses an algebraic syntax for ease of coding and readability. The architecture has been optimized for use in conjunction with the C/C++ compiler, resulting in fast and efficient software implementations.

MEMORY ARCHITECTURE

The ADSP-BF531/ADSP-BF532/ADSP-BF533 processors view memory as a single unified 4G byte address space, using 32-bit addresses. All resources, including internal memory, external memory, and I/O control registers, occupy separate sections of this common address space. The memory portions of this address space are arranged in a hierarchical structure to provide a good cost/performance balance of some very fast, low latency on-chip memory as cache or SRAM, and larger, lower cost and performance off-chip memory systems. See [Figure 3](#), [Figure 4](#), and [Figure 5 on Page 6](#).

The L1 memory system is the primary highest performance memory available to the Blackfin processor. The off-chip memory system, accessed through the external bus interface unit (EBIU), provides expansion with SDRAM, flash memory, and SRAM, optionally accessing up to 132M bytes of physical memory.

The memory DMA controller provides high bandwidth data-movement capability. It can perform block transfers of code or data between the internal memory and the external memory spaces.

Internal (On-Chip) Memory

The processors have three blocks of on-chip memory that provide high bandwidth access to the core.

The first block is the L1 instruction memory, consisting of up to 80K bytes SRAM, of which 16K bytes can be configured as a four way set-associative cache. This memory is accessed at full processor speed.

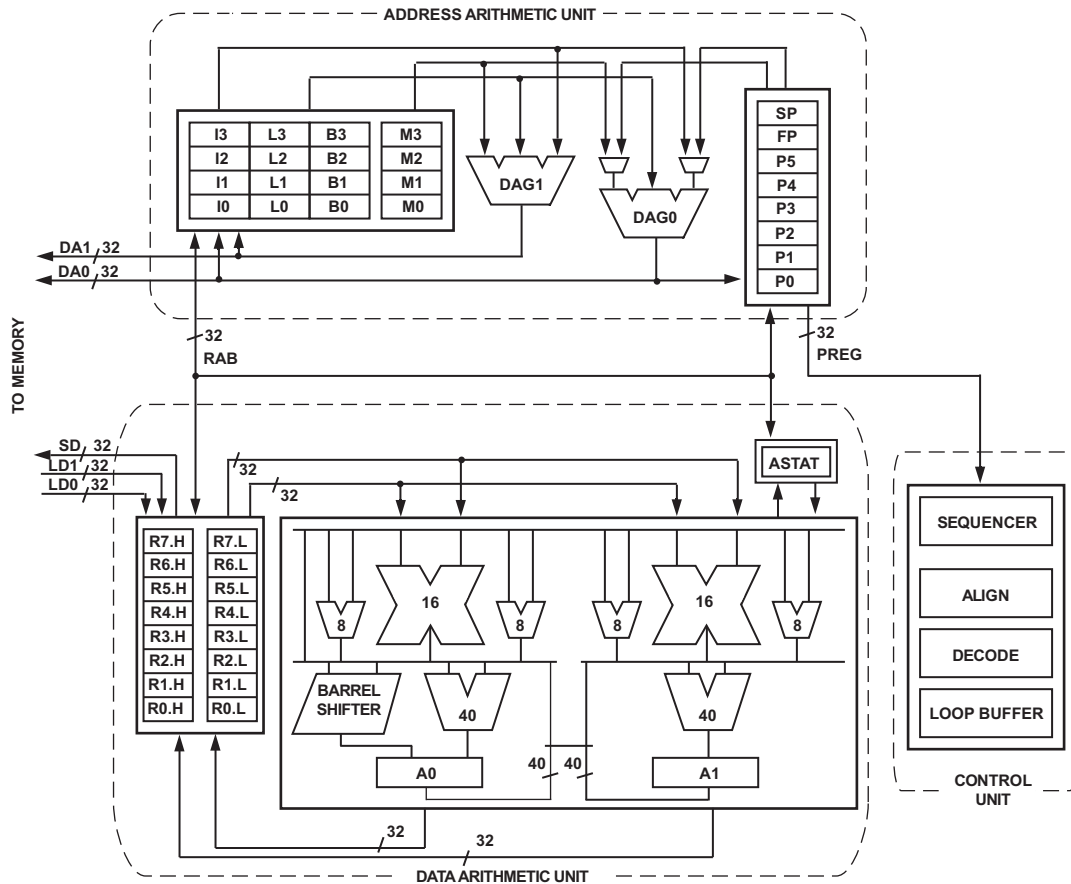

Figure 2. Blackfin Processor Core

The second on-chip memory block is the L1 data memory, consisting of one or two banks of up to 32K bytes. The memory banks are configurable, offering both cache and SRAM functionality. This memory block is accessed at full processor speed.

The third memory block is a 4K byte scratchpad SRAM, which runs at the same speed as the L1 memories, but is only accessible as data SRAM and cannot be configured as cache memory.

External (Off-Chip) Memory

External memory is accessed via the external bus interface unit (EBIU). This 16-bit interface provides a glueless connection to a bank of synchronous DRAM (SDRAM) as well as up to four banks of asynchronous memory devices including flash, EPROM, ROM, SRAM, and memory mapped I/O devices.

The PC133-compliant SDRAM controller can be programmed to interface to up to 128M bytes of SDRAM. The SDRAM controller allows one row to be open for each internal SDRAM bank, for up to four internal SDRAM banks, improving overall system performance.

The asynchronous memory controller can be programmed to control up to four banks of devices with very flexible timing parameters for a wide variety of devices. Each bank occupies a

1M byte segment regardless of the size of the devices used, so that these banks are only contiguous if each is fully populated with 1M byte of memory.

I/O Memory Space

Blackfin processors do not define a separate I/O space. All resources are mapped through the flat 32-bit address space. On-chip I/O devices have their control registers mapped into memory mapped registers (MMRs) at addresses near the top of the 4G byte address space. These are separated into two smaller blocks, one containing the control MMRs for all core functions, and the other containing the registers needed for setup and control of the on-chip peripherals outside of the core. The MMRs are accessible only in supervisor mode and appear as reserved space to on-chip peripherals.

Booting

The ADSP-BF531/ADSP-BF532/ADSP-BF533 processors contain a small boot kernel, which configures the appropriate peripheral for booting. If the processors are configured to boot from boot ROM memory space, the processor starts executing from the on-chip boot ROM. For more information, see [Booting Modes on Page 14](#).

ADSP-BF531/ADSP-BF532/ADSP-BF533

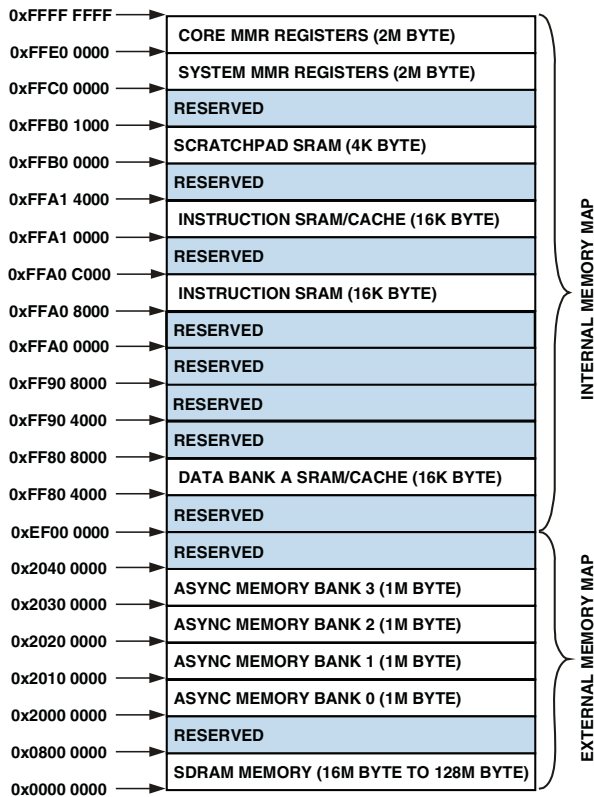

Figure 3. ADSP-BF531 Internal/External Memory Map

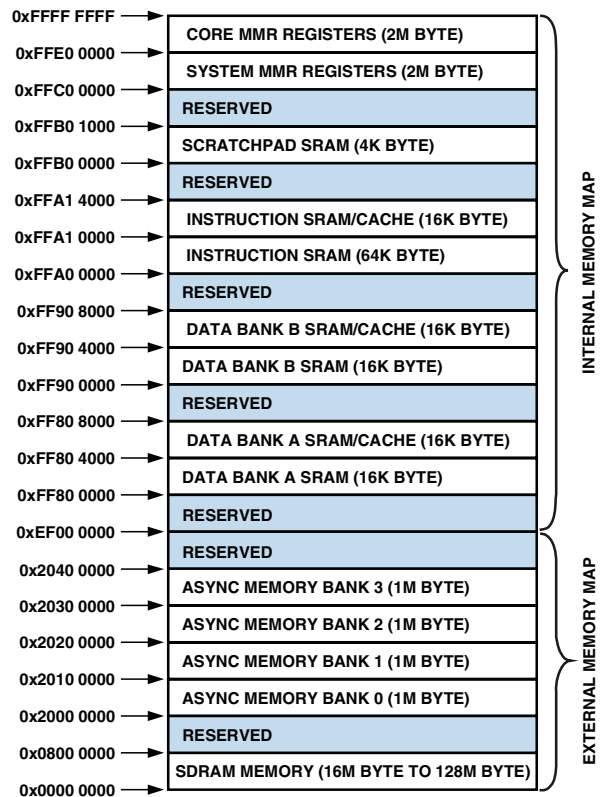

Figure 5. ADSP-BF533 Internal/External Memory Map

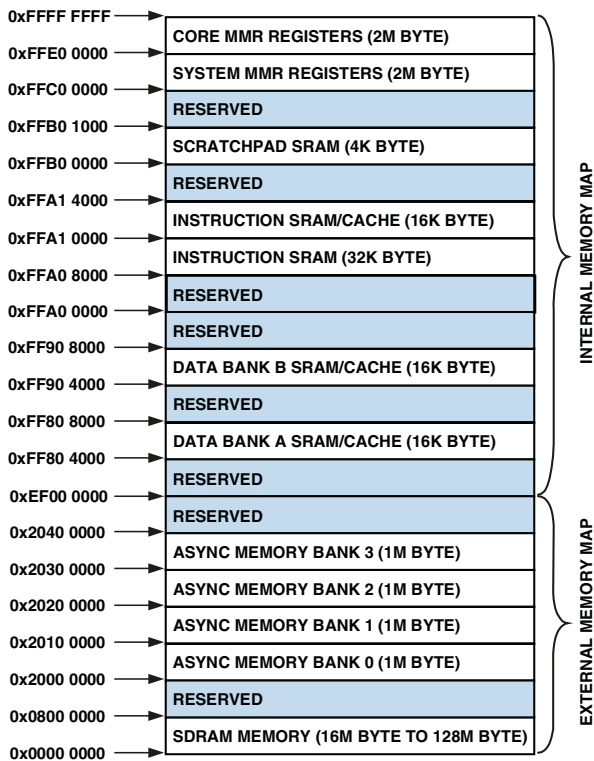

Figure 4. ADSP-BF532 Internal/External Memory Map

Event Handling

The event controller on the processors handle all asynchronous and synchronous events to the processor. The ADSP-BF531/ADSP-BF532/ADSP-BF533 processors provide event handling that supports both nesting and prioritization. Nesting allows multiple event service routines to be active simultaneously. Prioritization ensures that servicing of a higher priority event takes precedence over servicing of a lower priority event. The controller provides support for five different types of events:

- Emulation – An emulation event causes the processor to enter emulation mode, allowing command and control of the processor via the JTAG interface.
- Reset – This event resets the processor.
- Nonmaskable Interrupt (NMI) – The NMI event can be generated by the software watchdog timer or by the NMI input signal to the processor. The NMI event is frequently used as a power-down indicator to initiate an orderly shut-down of the system.
- Exceptions – Events that occur synchronously to program flow (i.e., the exception is taken before the instruction is allowed to complete). Conditions such as data alignment violations and undefined instructions cause exceptions.
- Interrupts – Events that occur asynchronously to program flow. They are caused by input pins, timers, and other peripherals, as well as by an explicit software instruction.

Each event type has an associated register to hold the return address and an associated return-from-event instruction. When an event is triggered, the state of the processor is saved on the supervisor stack.

The ADSP-BF531/ADSP-BF532/ADSP-BF533 processors' event controller consists of two stages, the core event controller (CEC) and the system interrupt controller (SIC). The core event controller works with the system interrupt controller to prioritize and control all system events. Conceptually, interrupts from the peripherals enter into the SIC, and are then routed directly into the general-purpose interrupts of the CEC.

Core Event Controller (CEC)

The CEC supports nine general-purpose interrupts (IVG15–7), in addition to the dedicated interrupt and exception events. Of these general-purpose interrupts, the two lowest priority interrupts (IVG15–14) are recommended to be reserved for software interrupt handlers, leaving seven prioritized interrupt inputs to support the peripherals of the processor. Table 2 describes the inputs to the CEC, identifies their names in the event vector table (EVT), and lists their priorities.

Table 2. Core Event Controller (CEC)

Priority (0 is Highest)	Event Class	EVT Entry
0	Emulation/Test Control	EMU
1	Reset	RST
2	Nonmaskable Interrupt	NMI
3	Exception	EVX
4	Reserved	
5	Hardware Error	IVHW
6	Core Timer	IVTMR
7	General Interrupt 7	IVG7
8	General Interrupt 8	IVG8
9	General Interrupt 9	IVG9
10	General Interrupt 10	IVG10
11	General Interrupt 11	IVG11
12	General Interrupt 12	IVG12
13	General Interrupt 13	IVG13
14	General Interrupt 14	IVG14
15	General Interrupt 15	IVG15

System Interrupt Controller (SIC)

The system interrupt controller provides the mapping and routing of events from the many peripheral interrupt sources to the prioritized general-purpose interrupt inputs of the CEC. Although the processors provide a default mapping, the user can alter the mappings and priorities of interrupt events by writing the appropriate values into the interrupt assignment registers (SIC_IARx). Table 3 describes the inputs into the SIC and the default mappings into the CEC.

Table 3. System Interrupt Controller (SIC)

Peripheral Interrupt Event	Default Mapping
PLL Wakeup	IVG7
DMA Error	IVG7
PPI Error	IVG7
SPORT 0 Error	IVG7
SPORT 1 Error	IVG7
SPI Error	IVG7
UART Error	IVG7
Real-Time Clock	IVG8
DMA Channel 0 (PPI)	IVG8
DMA Channel 1 (SPORT 0 Receive)	IVG9
DMA Channel 2 (SPORT 0 Transmit)	IVG9
DMA Channel 3 (SPORT 1 Receive)	IVG9
DMA Channel 4 (SPORT 1 Transmit)	IVG9
DMA Channel 5 (SPI)	IVG10
DMA Channel 6 (UART Receive)	IVG10
DMA Channel 7 (UART Transmit)	IVG10
Timer 0	IVG11
Timer 1	IVG11
Timer 2	IVG11
Port F GPIO Interrupt A	IVG12
Port F GPIO Interrupt B	IVG12
Memory DMA Stream 0	IVG13
Memory DMA Stream 1	IVG13
Software Watchdog Timer	IVG13

Event Control

The processors provide a very flexible mechanism to control the processing of events. In the CEC, three registers are used to coordinate and control events. Each register is 32 bits wide:

- CEC interrupt latch register (ILAT) – The ILAT register indicates when events have been latched. The appropriate bit is set when the processor has latched the event and cleared when the event has been accepted into the system. This register is updated automatically by the controller, but it can also be written to clear (cancel) latched events. This register can be read while in supervisor mode and can only be written while in supervisor mode when the corresponding IMASK bit is cleared.
- CEC interrupt mask register (IMASK) – The IMASK register controls the masking and unmasking of individual events. When a bit is set in the IMASK register, that event is unmasked and is processed by the CEC when asserted. A cleared bit in the IMASK register masks the event, preventing the processor from servicing the event even though the event may be latched in the ILAT register. This register can be read or written while in supervisor mode. Note that general-purpose interrupts can be globally enabled and disabled with the STI and CLI instructions, respectively.

ADSP-BF531/ADSP-BF532/ADSP-BF533

- CEC interrupt pending register (IPEND) – The IPEND register keeps track of all nested events. A set bit in the IPEND register indicates the event is currently active or nested at some level. This register is updated automatically by the controller but can be read while in supervisor mode.

The SIC allows further control of event processing by providing three 32-bit interrupt control and status registers. Each register contains a bit corresponding to each of the peripheral interrupt events shown in [Table 3](#).

- SIC interrupt mask register (SIC_IMASK) – This register controls the masking and unmasking of each peripheral interrupt event. When a bit is set in this register, that peripheral event is unmasked and is processed by the system when asserted. A cleared bit in this register masks the peripheral event, preventing the processor from servicing the event.
- SIC interrupt status register (SIC_ISR) – As multiple peripherals can be mapped to a single event, this register allows the software to determine which peripheral event source triggered the interrupt. A set bit indicates the peripheral is asserting the interrupt, and a cleared bit indicates the peripheral is not asserting the event.
- SIC interrupt wakeup enable register (SIC_IWR) – By enabling the corresponding bit in this register, a peripheral can be configured to wake up the processor, should the core be idled when the event is generated. See [Dynamic Power Management on Page 11](#).

Because multiple interrupt sources can map to a single general-purpose interrupt, multiple pulse assertions can occur simultaneously, before or during interrupt processing for an interrupt event already detected on this interrupt input. The IPEND register contents are monitored by the SIC as the interrupt acknowledgement.

The appropriate ILAT register bit is set when an interrupt rising edge is detected (detection requires two core clock cycles). The bit is cleared when the respective IPEND register bit is set. The IPEND bit indicates that the event has entered into the processor pipeline. At this point the CEC recognizes and queues the next rising edge event on the corresponding event input. The minimum latency from the rising edge transition of the general-purpose interrupt to the IPEND output asserted is three core clock cycles; however, the latency can be much higher, depending on the activity within and the state of the processor.

DMA CONTROLLERS

The ADSP-BF531/ADSP-BF532/ADSP-BF533 processors have multiple, independent DMA channels that support automated data transfers with minimal overhead for the processor core. DMA transfers can occur between the processor's internal memories and any of its DMA-capable peripherals. Additionally, DMA transfers can be accomplished between any of the DMA-capable peripherals and external devices connected to the external memory interfaces, including the SDRAM controller and the asynchronous memory controller. DMA-capable

peripherals include the SPORTs, SPI port, UART, and PPI. Each individual DMA-capable peripheral has at least one dedicated DMA channel.

The DMA controller supports both 1-dimensional (1-D) and 2-dimensional (2-D) DMA transfers. DMA transfer initialization can be implemented from registers or from sets of parameters called descriptor blocks.

The 2-D DMA capability supports arbitrary row and column sizes up to 64K elements by 64K elements, and arbitrary row and column step sizes up to $\pm 32K$ elements. Furthermore, the column step size can be less than the row step size, allowing implementation of interleaved data streams. This feature is especially useful in video applications where data can be de-interleaved on the fly.

Examples of DMA types supported by the DMA controller include:

- A single, linear buffer that stops upon completion
- A circular, autorefreshing buffer that interrupts on each full or fractionally full buffer
- 1-D or 2-D DMA using a linked list of descriptors
- 2-D DMA using an array of descriptors, specifying only the base DMA address within a common page

In addition to the dedicated peripheral DMA channels, there are two pairs of memory DMA channels provided for transfers between the various memories of the processor system. This enables transfers of blocks of data between any of the memories—including external SDRAM, ROM, SRAM, and flash memory—with minimal processor intervention. Memory DMA transfers can be controlled by a very flexible descriptor-based methodology or by a standard register-based autobuffer mechanism.

REAL-TIME CLOCK

The processor real-time clock (RTC) provides a robust set of digital watch features, including current time, stopwatch, and alarm. The RTC is clocked by a 32.768 kHz crystal external to the ADSP-BF531/ADSP-BF532/ADSP-BF533 processors. The RTC peripheral has dedicated power supply pins so that it can remain powered up and clocked even when the rest of the processor is in a low power state. The RTC provides several programmable interrupt options, including interrupt per second, minute, hour, or day clock ticks, interrupt on programmable stopwatch countdown, or interrupt at a programmed alarm time.

The 32.768 kHz input clock frequency is divided down to a 1 Hz signal by a prescaler. The counter function of the timer consists of four counters: a 60 second counter, a 60 minute counter, a 24 hour counter, and a 32,768 day counter.

When enabled, the alarm function generates an interrupt when the output of the timer matches the programmed value in the alarm control register. The two alarms are time of day and a day and time of that day.

The stopwatch function counts down from a programmed value, with one second resolution. When the stopwatch is enabled and the counter underflows, an interrupt is generated.

Like other peripherals, the RTC can wake up the processor from sleep mode upon generation of any RTC wakeup event. Additionally, an RTC wakeup event can wake up the processor from deep sleep mode, and wake up the on-chip internal voltage regulator from a powered-down state.

Connect RTC pins RTXI and RTXO with external components as shown in Figure 6.

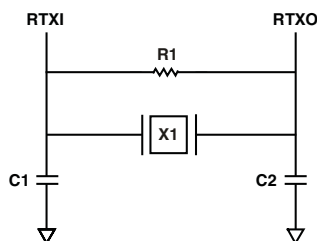

SUGGESTED COMPONENTS:
X1 = ECLIPTEK EC38J (THROUGH-HOLE PACKAGE) OR
EPSON MC405 12 pF LOAD (SURFACE-MOUNT PACKAGE)
C1 = 22 pF
C2 = 22 pF
R1 = 10 MΩ

NOTE: C1 AND C2 ARE SPECIFIC TO CRYSTAL SPECIFIED FOR X1. CONTACT CRYSTAL MANUFACTURER FOR DETAILS. C1 AND C2 SPECIFICATIONS ASSUME BOARD TRACE CAPACITANCE OF 3 pF.

Figure 6. External Components for RTC

WATCHDOG TIMER

The ADSP-BF531/ADSP-BF532/ADSP-BF533 processors include a 32-bit timer that can be used to implement a software watchdog function. A software watchdog can improve system availability by forcing the processor to a known state through generation of a hardware reset, nonmaskable interrupt (NMI), or general-purpose interrupt, if the timer expires before being reset by software. The programmer initializes the count value of the timer, enables the appropriate interrupt, then enables the timer. Thereafter, the software must reload the counter before it counts to zero from the programmed value. This protects the system from remaining in an unknown state where software, which would normally reset the timer, has stopped running due to an external noise condition or software error.

If configured to generate a hardware reset, the watchdog timer resets both the core and the processor peripherals. After a reset, software can determine if the watchdog was the source of the hardware reset by interrogating a status bit in the watchdog timer control register.

The timer is clocked by the system clock (SCLK), at a maximum frequency of f_{SCLK} .

TIMERS

There are four general-purpose programmable timer units in the ADSP-BF531/ADSP-BF532/ADSP-BF533 processors. Three timers have an external pin that can be configured either as a pulse-width modulator (PWM) or timer output, as an input to clock the timer, or as a mechanism for measuring pulse widths and periods of external events. These timers can be synchronized to an external clock input to the PF1 pin (TACLK), an external clock input to the PPI_CLK pin (TMRCLK), or to the internal SCLK.

The timer units can be used in conjunction with the UART to measure the width of the pulses in the data stream to provide an autobaud detect function for a serial channel.

The timers can generate interrupts to the processor core providing periodic events for synchronization, either to the system clock or to a count of external signals.

In addition to the three general-purpose programmable timers, a fourth timer is also provided. This extra timer is clocked by the internal processor clock and is typically used as a system tick clock for generation of operating system periodic interrupts.

SERIAL PORTS (SPORTs)

The ADSP-BF531/ADSP-BF532/ADSP-BF533 processors incorporate two dual-channel synchronous serial ports (SPORT0 and SPORT1) for serial and multiprocessor communications. The SPORTs support the following features:

- I²S capable operation.
- Bidirectional operation – Each SPORT has two sets of independent transmit and receive pins, enabling eight channels of I²S stereo audio.
- Buffered (8-deep) transmit and receive ports – Each port has a data register for transferring data words to and from other processor components and shift registers for shifting data in and out of the data registers.
- Clocking – Each transmit and receive port can either use an external serial clock or generate its own, in frequencies ranging from ($f_{SCLK}/131,070$) Hz to ($f_{SCLK}/2$) Hz.
- Word length – Each SPORT supports serial data words from 3 bits to 32 bits in length, transferred most-significant-bit first or least-significant-bit first.
- Framing – Each transmit and receive port can run with or without frame sync signals for each data word. Frame sync signals can be generated internally or externally, active high or low, and with either of two pulse widths and early or late frame sync.
- Companding in hardware – Each SPORT can perform A-law or μ -law companding according to ITU recommendation G.711. Companding can be selected on the transmit and/or receive channel of the SPORT without additional latencies.
- DMA operations with single-cycle overhead – Each SPORT can automatically receive and transmit multiple buffers of memory data. The processor can link or chain sequences of DMA transfers between a SPORT and memory.

ADSP-BF531/ADSP-BF532/ADSP-BF533

- Interrupts – Each transmit and receive port generates an interrupt upon completing the transfer of a data-word or after transferring an entire data buffer or buffers through DMA.
- Multichannel capability – Each SPORT supports 128 channels out of a 1,024-channel window and is compatible with the H.100, H.110, MVIP-90, and HMVIP standards.

An additional 250 mV of SPORT input hysteresis can be enabled by setting Bit 15 of the PLL_CTL register. When this bit is set, all SPORT input pins have the increased hysteresis.

SERIAL PERIPHERAL INTERFACE (SPI) PORT

The ADSP-BF531/ADSP-BF532/ADSP-BF533 processors have an SPI-compatible port that enables the processor to communicate with multiple SPI-compatible devices.

The SPI interface uses three pins for transferring data: two data pins (master output-slave input, MOSI, and master input-slave output, MISO) and a clock pin (serial clock, SCK). An SPI chip select input pin ($\overline{\text{SPISS}}$) lets other SPI devices select the processor, and seven SPI chip select output pins ($\overline{\text{SPISEL7-1}}$) let the processor select other SPI devices. The SPI select pins are reconfigured general-purpose I/O pins. Using these pins, the SPI port provides a full-duplex, synchronous serial interface which supports both master/slave modes and multimaster environments.

The baud rate and clock phase/polarities for the SPI port are programmable, and it has an integrated DMA controller, configurable to support transmit or receive data streams. The SPI DMA controller can only service unidirectional accesses at any given time.

The SPI port clock rate is calculated as:

$$\text{SPI Clock Rate} = \frac{f_{\text{SCLK}}}{2 \times \text{SPI_BAUD}}$$

where the 16-bit SPI_BAUD register contains a value of 2 to 65,535.

During transfers, the SPI port simultaneously transmits and receives by serially shifting data in and out on its two serial data lines. The serial clock line synchronizes the shifting and sampling of data on the two serial data lines.

UART PORT

The ADSP-BF531/ADSP-BF532/ADSP-BF533 processors provide a full-duplex universal asynchronous receiver/transmitter (UART) port, which is fully compatible with PC-standard UARTs. The UART port provides a simplified UART interface to other peripherals or hosts, supporting full-duplex, DMA-supported, asynchronous transfers of serial data. The UART port includes support for 5 data bits to 8 data bits, 1 stop bit or 2 stop bits, and none, even, or odd parity. The UART port supports two modes of operation:

- PIO (programmed I/O) – The processor sends or receives data by writing or reading I/O-mapped UART registers. The data is double-buffered on both transmit and receive.

- DMA (direct memory access) – The DMA controller transfers both transmit and receive data. This reduces the number and frequency of interrupts required to transfer data to and from memory. The UART has two dedicated DMA channels, one for transmit and one for receive. These DMA channels have lower default priority than most DMA channels because of their relatively low service rates.

The baud rate, serial data format, error code generation and status, and interrupts for the UART port are programmable.

The UART programmable features include:

- Supporting bit rates ranging from ($f_{\text{SCLK}}/1,048,576$) bits per second to ($f_{\text{SCLK}}/16$) bits per second.
- Supporting data formats from seven bits to 12 bits per frame.
- Both transmit and receive operations can be configured to generate maskable interrupts to the processor.

The UART port's clock rate is calculated as:

$$\text{UART Clock Rate} = \frac{f_{\text{SCLK}}}{16 \times \text{UART_Divisor}}$$

where the 16-bit UART_Divisor comes from the UART_DLH register (most significant 8 bits) and UART_DLL register (least significant 8 bits).

In conjunction with the general-purpose timer functions, autobaud detection is supported.

The capabilities of the UART are further extended with support for the Infrared Data Association (IrDA[®]) serial infrared physical layer link specification (SIR) protocol.

GENERAL-PURPOSE I/O PORT F

The ADSP-BF531/ADSP-BF532/ADSP-BF533 processors have 16 bidirectional, general-purpose I/O pins on Port F (PF15–0). Each general-purpose I/O pin can be individually controlled by manipulation of the GPIO control, status and interrupt registers:

- GPIO direction control register – Specifies the direction of each individual PFx pin as input or output.
- GPIO control and status registers – The processor employs a “write one to modify” mechanism that allows any combination of individual GPIO pins to be modified in a single instruction, without affecting the level of any other GPIO pins. Four control registers are provided. One register is written in order to set GPIO pin values, one register is written in order to clear GPIO pin values, one register is written in order to toggle GPIO pin values, and one register is written in order to specify GPIO pin values. Reading the GPIO status register allows software to interrogate the sense of the GPIO pin.
- GPIO interrupt mask registers – The two GPIO interrupt mask registers allow each individual PFx pin to function as an interrupt to the processor. Similar to the two GPIO control registers that are used to set and clear individual GPIO pin values, one GPIO interrupt mask register sets bits to enable interrupt function, and the other GPIO interrupt mask register clears bits to disable interrupt function.

PfX pins defined as inputs can be configured to generate hardware interrupts, while output PfX pins can be triggered by software interrupts.

- GPIO interrupt sensitivity registers – The two GPIO interrupt sensitivity registers specify whether individual PfX pins are level- or edge-sensitive and specify—if edge-sensitive—whether just the rising edge or both the rising and falling edges of the signal are significant. One register selects the type of sensitivity, and one register selects which edges are significant for edge-sensitivity.

PARALLEL PERIPHERAL INTERFACE

The processors provide a parallel peripheral interface (PPI) that can connect directly to parallel ADCs and DACs, video encoders and decoders, and other general-purpose peripherals. The PPI consists of a dedicated input clock pin, up to three frame synchronization pins, and up to 16 data pins. The input clock supports parallel data rates up to half the system clock rate and the synchronization signals can be configured as either inputs or outputs.

The PPI supports a variety of general-purpose and ITU-R 656 modes of operation. In general-purpose mode, the PPI provides half-duplex, bi-directional data transfer with up to 16 bits of data. Up to three frame synchronization signals are also provided. In ITU-R 656 mode, the PPI provides half-duplex bi-directional transfer of 8- or 10-bit video data. Additionally, on-chip decode of embedded start-of-line (SOL) and start-of-field (SOF) preamble packets is supported.

General-Purpose Mode Descriptions

The general-purpose modes of the PPI are intended to suit a wide variety of data capture and transmission applications.

Three distinct sub modes are supported:

- Input mode – Frame syncs and data are inputs into the PPI.
- Frame capture mode – Frame syncs are outputs from the PPI, but data are inputs.
- Output mode – Frame syncs and data are outputs from the PPI.

Input Mode

Input mode is intended for ADC applications, as well as video communication with hardware signaling. In its simplest form, PPI_FS1 is an external frame sync input that controls when to read data. The PPI_DELAY MMR allows for a delay (in PPI_CLK cycles) between reception of this frame sync and the initiation of data reads. The number of input data samples is user programmable and defined by the contents of the PPI_COUNT register. The PPI supports 8-bit and 10-bit through 16-bit data, programmable in the PPI_CONTROL register.

Frame Capture Mode

Frame capture mode allows the video source(s) to act as a slave (e.g., for frame capture). The processors control when to read from the video source(s). PPI_FS1 is an HSYNC output and PPI_FS2 is a VSYNC output.

Output Mode

Output mode is used for transmitting video or other data with up to three output frame syncs. Typically, a single frame sync is appropriate for data converter applications, whereas two or three frame syncs could be used for sending video with hardware signaling.

ITU-R 656 Mode Descriptions

The ITU-R 656 modes of the PPI are intended to suit a wide variety of video capture, processing, and transmission applications. Three distinct sub modes are supported:

- Active video only mode
- Vertical blanking only mode
- Entire field mode

Active Video Only Mode

Active video only mode is used when only the active video portion of a field is of interest and not any of the blanking intervals. The PPI does not read in any data between the end of active video (EAV) and start of active video (SAV) preamble symbols, or any data present during the vertical blanking intervals. In this mode, the control byte sequences are not stored to memory; they are filtered by the PPI. After synchronizing to the start of Field 1, the PPI ignores incoming samples until it sees an SAV code. The user specifies the number of active video lines per frame (in PPI_COUNT register).

Vertical Blanking Interval Mode

In this mode, the PPI only transfers vertical blanking interval (VBI) data.

Entire Field Mode

In this mode, the entire incoming bit stream is read in through the PPI. This includes active video, control preamble sequences, and ancillary data that can be embedded in horizontal and vertical blanking intervals. Data transfer starts immediately after synchronization to Field 1. Data is transferred to or from the synchronous channels through eight DMA engines that work autonomously from the processor core.

DYNAMIC POWER MANAGEMENT

The ADSP-BF531/ADSP-BF532/ADSP-BF533 processors provides four operating modes, each with a different performance/power profile. In addition, dynamic power management provides the control functions to dynamically alter the processor core supply voltage, further reducing power dissipation. Control of clocking to each of the processor peripherals also reduces power consumption. See [Table 4](#) for a summary of the power settings for each mode.

Full-On Operating Mode—Maximum Performance

In the full-on mode, the PLL is enabled and is not bypassed, providing capability for maximum operational frequency. This is the power-up default execution state in which maximum performance can be achieved. The processor core and all enabled peripherals run at full speed.

ADSP-BF531/ADSP-BF532/ADSP-BF533

Active Operating Mode—Moderate Power Savings

In the active mode, the PLL is enabled but bypassed. Because the PLL is bypassed, the processor's core clock (CCLK) and system clock (SCLK) run at the input clock (CLKIN) frequency. DMA access is available to appropriately configured L1 memories.

In the active mode, it is possible to disable the PLL through the PLL control register (PLL_CTL). If disabled, the PLL must be re-enabled before it can transition to the full-on or sleep modes.

Table 4. Power Settings

Mode	PLL	PLL Bypassed	Core Clock (CCLK)	System Clock (SCLK)	Internal Power (V _{DDINT})
Full On	Enabled	No	Enabled	Enabled	On
Active	Enabled/Disabled	Yes	Enabled	Enabled	On
Sleep	Enabled	—	Disabled	Enabled	On
Deep Sleep	Disabled	—	Disabled	Disabled	On
Hibernate	Disabled	—	Disabled	Disabled	Off

Sleep Operating Mode—High Dynamic Power Savings

The sleep mode reduces dynamic power dissipation by disabling the clock to the processor core (CCLK). The PLL and system clock (SCLK), however, continue to operate in this mode. Typically an external event or RTC activity will wake up the processor. When in the sleep mode, assertion of wakeup causes the processor to sense the value of the BYPASS bit in the PLL control register (PLL_CTL). If BYPASS is disabled, the processor will transition to the full-on mode. If BYPASS is enabled, the processor will transition to the active mode.

When in the sleep mode, system DMA access to L1 memory is not supported.

Deep Sleep Operating Mode—Maximum Dynamic Power Savings

The deep sleep mode maximizes dynamic power savings by disabling the clocks to the processor core (CCLK) and to all synchronous peripherals (SCLK). Asynchronous peripherals, such as the RTC, may still be running but cannot access internal resources or external memory. This powered-down mode can only be exited by assertion of the reset interrupt (RESET) or by an asynchronous interrupt generated by the RTC. When in deep sleep mode, an RTC asynchronous interrupt causes the processor to transition to the active mode. Assertion of RESET while in deep sleep mode causes the processor to transition to the full-on mode.

Hibernate State—Maximum Static Power Savings

The hibernate state maximizes static power savings by disabling the voltage and clocks to the processor core (CCLK) and to all the synchronous peripherals (SCLK). The internal voltage regulator for the processor can be shut off by writing b#00 to the FREQ bits of the VR_CTL register. In addition to disabling the clocks, this sets the internal power supply voltage (V_{DDINT}) to

0 V to provide the lowest static power dissipation. Any critical information stored internally (memory contents, register contents, etc.) must be written to a nonvolatile storage device prior to removing power if the processor state is to be preserved. Since V_{DDEXT} is still supplied in this mode, all of the external pins three-state, unless otherwise specified. This allows other devices that may be connected to the processor to still have power applied without drawing unwanted current. The internal supply regulator can be woken up either by a real-time clock wakeup or by asserting the RESET pin.

Power Savings

As shown in Table 5, the processors support three different power domains. The use of multiple power domains maximizes flexibility, while maintaining compliance with industry standards and conventions. By isolating the internal logic of the processor into its own power domain, separate from the RTC and other I/O, the processor can take advantage of dynamic power management without affecting the RTC or other I/O devices. There are no sequencing requirements for the various power domains.

Table 5. Power Domains

Power Domain	V _{DD} Range
All internal logic, except RTC	V _{DDINT}
RTC internal logic and crystal I/O	V _{DDRTC}
All other I/O	V _{DDEXT}

The power dissipated by a processor is largely a function of the clock frequency of the processor and the square of the operating voltage. For example, reducing the clock frequency by 25% results in a 25% reduction in dynamic power dissipation, while reducing the voltage by 25% reduces dynamic power dissipation by more than 40%. Further, these power savings are additive, in that if the clock frequency and supply voltage are both reduced, the power savings can be dramatic.

The dynamic power management feature of the processor allows both the processor's input voltage (V_{DDINT}) and clock frequency (f_{CCLK}) to be dynamically controlled.

The savings in power dissipation can be modeled using the power savings factor and % power savings calculations.

The power savings factor is calculated as:

$$\text{power savings factor} = \frac{f_{\text{CCLKRED}}}{f_{\text{CCLKNOM}}} \times \left(\frac{V_{\text{DDINTRED}}}{V_{\text{DDINTNOM}}} \right)^2 \times \left(\frac{t_{\text{RED}}}{t_{\text{NOM}}} \right)$$

where the variables in the equation are:

f_{CCLKNOM} is the nominal core clock frequency

f_{CCLKRED} is the reduced core clock frequency

V_{DDINTNOM} is the nominal internal supply voltage

V_{DDINTRED} is the reduced internal supply voltage

ADSP-BF531/ADSP-BF532/ADSP-BF533

t_{NOM} is the duration running at $f_{CCLKNOM}$

t_{RED} is the duration running at $f_{CCLKRED}$

The percent power savings is calculated as:

$$\% \text{ power savings} = (1 - \text{power savings factor}) \times 100\%$$

VOLTAGE REGULATION

The Blackfin processor provides an on-chip voltage regulator that can generate appropriate V_{DDINT} voltage levels from the V_{DDEXT} supply. See [Operating Conditions on Page 20](#) for regulator tolerances and acceptable V_{DDEXT} ranges for specific models.

Figure 7 shows the typical external components required to complete the power management system. The regulator controls the internal logic voltage levels and is programmable with the voltage regulator control register (VR_CTL) in increments of 50 mV. To reduce standby power consumption, the internal voltage regulator can be programmed to remove power to the processor core while keeping I/O power (V_{DDEXT}) supplied. While in the hibernate state, I/O power is still being applied, eliminating the need for external buffers. The voltage regulator can be activated from this power-down state either through an RTC wakeup or by asserting RESET, both of which initiate a boot sequence. The regulator can also be disabled and bypassed at the user's discretion.

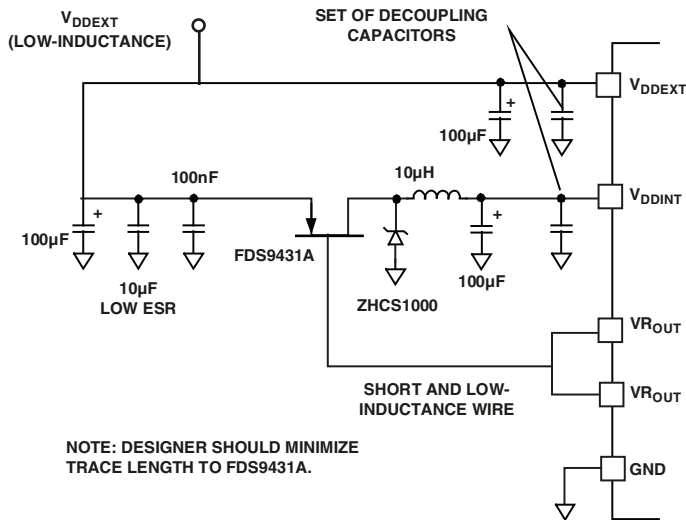

Figure 7. Voltage Regulator Circuit

Voltage Regulator Layout Guidelines

Regulator external component placement, board routing, and bypass capacitors all have a significant effect on noise injected into the other analog circuits on-chip. The VR_OUT1–0 traces and voltage regulator external components should be considered as noise sources when doing board layout and should not be routed or placed near sensitive circuits or components on the board. All internal and I/O power supplies should be well bypassed with bypass capacitors placed as close to the processors as possible.

For further details on the on-chip voltage regulator and related board design guidelines, see the *Switching Regulator Design Considerations for ADSP-BF533 Blackfin Processors (EE-228)* applications note on the Analog Devices web site (www.analog.com)—use site search on “EE-228”.

CLOCK SIGNALS

The ADSP-BF531/ADSP-BF532/ADSP-BF533 processors can be clocked by an external crystal, a sine wave input, or a buffered, shaped clock derived from an external clock oscillator.

If an external clock is used, it should be a TTL-compatible signal and must not be halted, changed, or operated below the specified frequency during normal operation. This signal is connected to the processor's CLKIN pin. When an external clock is used, the XTAL pin must be left unconnected.

Alternatively, because the processors include an on-chip oscillator circuit, an external crystal can be used. For fundamental frequency operation, use the circuit shown in Figure 8.

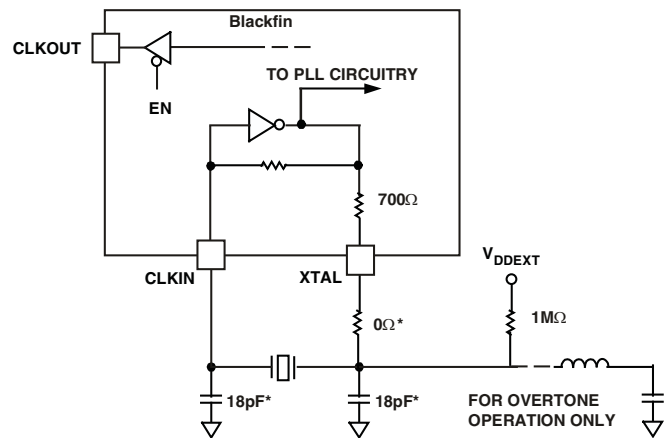

NOTE: VALUES MARKED WITH * MUST BE CUSTOMIZED DEPENDING ON THE CRYSTAL AND LAYOUT. PLEASE ANALYZE CAREFULLY.

Figure 8. External Crystal Connections

A parallel-resonant, fundamental frequency, microprocessor-grade crystal is connected across the CLKIN and XTAL pins. The on-chip resistance between CLKIN and the XTAL pin is in the 500 kΩ range. Further parallel resistors are typically not recommended. The two capacitors and the series resistor shown in Figure 8 fine tune the phase and amplitude of the sine frequency. The capacitor and resistor values shown in Figure 8 are typical values only. The capacitor values are dependent upon the crystal manufacturer's load capacitance recommendations and the physical PCB layout. The resistor value depends on the drive level specified by the crystal manufacturer. System designs should verify the customized values based on careful investigation on multiple devices over the allowed temperature range.

A third-overtone crystal can be used at frequencies above 25 MHz. The circuit is then modified to ensure crystal operation only at the third overtone, by adding a tuned inductor circuit as shown in Figure 8.

ADSP-BF531/ADSP-BF532/ADSP-BF533

As shown in Figure 9, the core clock (CCLK) and system peripheral clock (SCLK) are derived from the input clock (CLKIN) signal. An on-chip PLL is capable of multiplying the CLKIN signal by a user programmable 0.5× to 64× multiplication factor (bounded by specified minimum and maximum VCO frequencies). The default multiplier is 10×, but it can be modified by a software instruction sequence. On-the-fly frequency changes can be effected by simply writing to the PLL_DIV register.

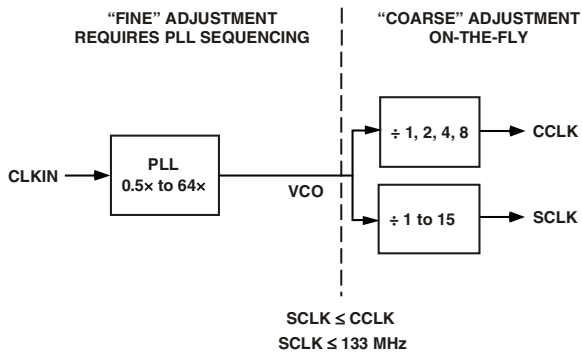

Figure 9. Frequency Modification Methods

All on-chip peripherals are clocked by the system clock (SCLK). The system clock frequency is programmable by means of the SSEL3–0 bits of the PLL_DIV register. The values programmed into the SSEL fields define a divide ratio between the PLL output (VCO) and the system clock. SCLK divider values are 1 through 15. Table 6 illustrates typical system clock ratios.

Table 6. Example System Clock Ratios

Signal Name SSEL3–0	Divider Ratio VCO/SCLK	Example Frequency Ratios (MHz)	
		VCO	SCLK
0001	1:1	100	100
0101	5:1	400	80
1010	10:1	500	50

The maximum frequency of the system clock is f_{SCLK} . The divisor ratio must be chosen to limit the system clock frequency to its maximum of f_{SCLK} . The SSEL value can be changed dynamically without any PLL lock latencies by writing the appropriate values to the PLL divisor register (PLL_DIV). When the SSEL value is changed, it affects all of the peripherals that derive their clock signals from the SCLK signal.

The core clock (CCLK) frequency can also be dynamically changed by means of the CSEL1–0 bits of the PLL_DIV register. Supported CCLK divider ratios are 1, 2, 4, and 8, as shown in Table 7. This programmable core clock capability is useful for fast core frequency modifications.

Table 7. Core Clock Ratios

Signal Name CSEL1–0	Divider Ratio VCO/CCLK	Example Frequency Ratios (MHz)	
		VCO	CCLK
00	1:1	300	300
01	2:1	300	150
10	4:1	400	100
11	8:1	200	25

BOOTING MODES

The ADSP-BF531/ADSP-BF532/ADSP-BF533 processors have two mechanisms (listed in Table 8) for automatically loading internal L1 instruction memory after a reset. A third mode is provided to execute from external memory, bypassing the boot sequence.

Table 8. Booting Modes

BMODE1–0	Description
00	Execute from 16-bit external memory (bypass boot ROM)
01	Boot from 8-bit or 16-bit FLASH
10	Boot from serial master connected to SPI
11	Boot from serial slave EEPROM/flash (8-, 16-, or 24-bit address range, or Atmel AT45DB041, AT45DB081, or AT45DB161 serial flash)

The BMODE pins of the reset configuration register, sampled during power-on resets and software-initiated resets, implement the following modes:

- Execute from 16-bit external memory – Execution starts from address 0x2000 0000 with 16-bit packing. The boot ROM is bypassed in this mode. All configuration settings are set for the slowest device possible (3-cycle hold time; 15-cycle R/W access times; 4-cycle setup).
- Boot from 8-bit or 16-bit external flash memory – The flash boot routine located in boot ROM memory space is set up using asynchronous Memory Bank 0. All configuration settings are set for the slowest device possible (3-cycle hold time; 15-cycle R/W access times; 4-cycle setup).
- Boot from SPI serial EEPROM/flash (8-, 16-, or 24-bit addressable, or Atmel AT45DB041, AT45DB081, or AT45DB161) – The SPI uses the PF2 output pin to select a single SPI EEPROM/flash device, submits a read command and successive address bytes (0x00) until a valid 8-, 16-, or 24-bit addressable EEPROM/flash device is detected, and begins clocking data into the processor at the beginning of L1 instruction memory.
- Boot from SPI serial master – The Blackfin processor operates in SPI slave mode and is configured to receive the bytes of the LDR file from an SPI host (master) agent. To hold off the host device from transmitting while the boot ROM is busy, the Blackfin processor asserts a GPIO pin, called host wait (HWAIT), to signal the host device not to send any

more bytes until the flag is deasserted. The GPIO pin is chosen by the user and this information is transferred to the Blackfin processor via bits[10:5] of the FLAG header in the LDR image.

For each of the boot modes, a 10-byte header is first read from an external memory device. The header specifies the number of bytes to be transferred and the memory destination address. Multiple memory blocks can be loaded by any boot sequence. Once all blocks are loaded, program execution commences from the start of L1 instruction SRAM.

In addition, Bit 4 of the reset configuration register can be set by application code to bypass the normal boot sequence during a software reset. For this case, the processor jumps directly to the beginning of L1 instruction memory.

INSTRUCTION SET DESCRIPTION

The Blackfin processor family assembly language instruction set employs an algebraic syntax designed for ease of coding and readability. The instructions have been specifically tuned to provide a flexible, densely encoded instruction set that compiles to a very small final memory size. The instruction set also provides fully featured multifunction instructions that allow the programmer to use many of the processor core resources in a single instruction. Coupled with many features more often seen on microcontrollers, this instruction set is very efficient when compiling C and C++ source code. In addition, the architecture supports both user (algorithm/application code) and supervisor (O/S kernel, device drivers, debuggers, ISRs) modes of operation, allowing multiple levels of access to core processor resources.

The assembly language, which takes advantage of the processor's unique architecture, offers the following advantages:

- Seamlessly integrated DSP/CPU features are optimized for both 8-bit and 16-bit operations.
- A multi-issue load/store modified Harvard architecture, which supports two 16-bit MAC or four 8-bit ALU + two load/store + two pointer updates per cycle.
- All registers, I/O, and memory are mapped into a unified 4G byte memory space, providing a simplified programming model.
- Microcontroller features, such as arbitrary bit and bit-field manipulation, insertion, and extraction; integer operations on 8-, 16-, and 32-bit data types; and separate user and supervisor stack pointers.
- Code density enhancements, which include intermixing of 16-bit and 32-bit instructions (no mode switching, no code segregation). Frequently used instructions are encoded in 16 bits.

DEVELOPMENT TOOLS

Analog Devices supports its processors with a complete line of software and hardware development tools, including integrated development environments (which include CrossCore[®] Embedded Studio and/or VisualDSP++[®]), evaluation products, emulators, and a wide variety of software add-ins.

Integrated Development Environments (IDEs)

For C/C++ software writing and editing, code generation, and debug support, Analog Devices offers two IDEs.

The newest IDE, CrossCore Embedded Studio, is based on the Eclipse™ framework. Supporting most Analog Devices processor families, it is the IDE of choice for future processors, including multicore devices. CrossCore Embedded Studio seamlessly integrates available software add-ins to support real time operating systems, file systems, TCP/IP stacks, USB stacks, algorithmic software modules, and evaluation hardware board support packages. For more information visit www.analog.com/cces.

The other Analog Devices IDE, VisualDSP++, supports processor families introduced prior to the release of CrossCore Embedded Studio. This IDE includes the Analog Devices VDK real time operating system and an open source TCP/IP stack. For more information visit www.analog.com/visualdsp. Note that VisualDSP++ will not support future Analog Devices processors.

EZ-KIT Lite Evaluation Board

For processor evaluation, Analog Devices provides wide range of EZ-KIT Lite[®] evaluation boards. Including the processor and key peripherals, the evaluation board also supports on-chip emulation capabilities and other evaluation and development features. Also available are various EZ-Extenders[®], which are daughter cards delivering additional specialized functionality, including audio and video processing. For more information visit www.analog.com and search on “ezkit” or “ezextender”.

EZ-KIT Lite Evaluation Kits

For a cost-effective way to learn more about developing with Analog Devices processors, Analog Devices offer a range of EZ-KIT Lite evaluation kits. Each evaluation kit includes an EZ-KIT Lite evaluation board, directions for downloading an evaluation version of the available IDE(s), a USB cable, and a power supply. The USB controller on the EZ-KIT Lite board connects to the USB port of the user's PC, enabling the chosen IDE evaluation suite to emulate the on-board processor in-circuit. This permits the customer to download, execute, and debug programs for the EZ-KIT Lite system. It also supports in-circuit programming of the on-board Flash device to store user-specific boot code, enabling standalone operation. With the full version of CrossCore Embedded Studio or VisualDSP++ installed (sold separately), engineers can develop software for supported EZ-KITs or any custom system utilizing supported Analog Devices processors.

Software Add-Ins for CrossCore Embedded Studio

Analog Devices offers software add-ins which seamlessly integrate with CrossCore Embedded Studio to extend its capabilities and reduce development time. Add-ins include board support packages for evaluation hardware, various middleware packages, and algorithmic modules. Documentation, help, configuration dialogs, and coding examples present in these add-ins are viewable through the CrossCore Embedded Studio IDE once the add-in is installed.

ADSP-BF531/ADSP-BF532/ADSP-BF533

Board Support Packages for Evaluation Hardware

Software support for the EZ-KIT Lite evaluation boards and EZ-Extender daughter cards is provided by software add-ins called Board Support Packages (BSPs). The BSPs contain the required drivers, pertinent release notes, and select example code for the given evaluation hardware. A download link for a specific BSP is located on the web page for the associated EZ-KIT or EZ-Extender product. The link is found in the *Product Download* area of the product web page.

Middleware Packages

Analog Devices separately offers middleware add-ins such as real time operating systems, file systems, USB stacks, and TCP/IP stacks. For more information see the following web pages:

- www.analog.com/ucos3
- www.analog.com/ucfs
- www.analog.com/ucusb
- www.analog.com/lwip

Algorithmic Modules

To speed development, Analog Devices offers add-ins that perform popular audio and video processing algorithms. These are available for use with both CrossCore Embedded Studio and VisualDSP++. For more information visit www.analog.com and search on “Blackfin software modules” or “SHARC software modules”.

Designing an Emulator-Compatible DSP Board (Target)

For embedded system test and debug, Analog Devices provides a family of emulators. On each JTAG DSP, Analog Devices supplies an IEEE 1149.1 JTAG Test Access Port (TAP). In-circuit emulation is facilitated by use of this JTAG interface. The emulator accesses the processor’s internal features via the processor’s TAP, allowing the developer to load code, set breakpoints, and view variables, memory, and registers. The processor must be halted to send data and commands, but once an operation is completed by the emulator, the DSP system is set to run at full speed with no impact on system timing. The emulators require the target board to include a header that supports connection of the DSP’s JTAG port to the emulator.

For details on target board design issues including mechanical layout, single processor connections, signal buffering, signal termination, and emulator pod logic, see the Engineer-to-Engineer Note “*Analog Devices JTAG Emulation Technical Reference*” (EE-68) on the Analog Devices website (www.analog.com)—use site search on “EE-68.” This document is updated regularly to keep pace with improvements to emulator support.

ADDITIONAL INFORMATION

The following publications that describe the ADSP-BF531/ADSP-BF532/ADSP-BF533 processors (and related processors) can be ordered from any Analog Devices sales office or accessed electronically on our website:

- *Getting Started With Blackfin Processors*
- *ADSP-BF533 Blackfin Processor Hardware Reference*
- *Blackfin Processor Programming Reference*
- *ADSP-BF531/ADSP-BF532/ADSP-BF533 Blackfin Processor Anomaly List*

RELATED SIGNAL CHAINS

A *signal chain* is a series of signal-conditioning electronic components that receive input (data acquired from sampling either real-time phenomena or from stored data) in tandem, with the output of one portion of the chain supplying input to the next. Signal chains are often used in signal processing applications to gather and process data or to apply system controls based on analysis of real-time phenomena. For more information about this term and related topics, see the “signal chain” entry in [Wikipedia](http://en.wikipedia.org) or the [Glossary of EE Terms](#) on the Analog Devices website.

Analog Devices eases signal processing system development by providing signal processing components that are designed to work together well. A tool for viewing relationships between specific applications and related components is available on the www.analog.com website.

The Application Signal Chains page in the Circuits from the Lab™ site (<http://www.analog.com/circuits>) provides:

- Graphical circuit block diagram presentation of signal chains for a variety of circuit types and applications
- Drill down links for components in each chain to selection guides and application information
- Reference designs applying best practice design techniques

PIN DESCRIPTIONS

The ADSP-BF531/ADSP-BF532/ADSP-BF533 processors pin definitions are listed in [Table 9](#).

All pins are three-stated during and immediately after reset, except the memory interface, asynchronous memory control, and synchronous memory control pins. These pins are all driven high, with the exception of CLKOUT, which toggles at the system clock rate. During hibernate, all outputs are three-stated unless otherwise noted in [Table 9](#).

If \overline{BR} is active (whether or not \overline{RESET} is asserted), the memory pins are also three-stated. All unused I/O pins have their input buffers disabled with the exception of the pins that need pull-ups or pull-downs as noted in the table.

In order to maintain maximum functionality and reduce package size and pin count, some pins have dual, multiplexed functionality. In cases where pin functionality is reconfigurable, the default state is shown in plain text, while alternate functionality is shown in italics.

Table 9. Pin Descriptions

Pin Name	Type	Function	Driver Type ¹
<i>Memory Interface</i>			
ADDR19–1	O	Address Bus for Async/Sync Access	A
DATA15–0	I/O	Data Bus for Async/Sync Access	A
$\overline{ABE1-0/SDQM1-0}$	O	Byte Enables/Data Masks for Async/Sync Access	A
\overline{BR}	I	Bus Request (This pin should be pulled high if not used.)	
\overline{BG}	O	Bus Grant	A
\overline{BGH}	O	Bus Grant Hang	A
<i>Asynchronous Memory Control</i>			
$\overline{AMS3-0}$	O	Bank Select (Require pull-ups if hibernate is used.)	A
ARDY	I	Hardware Ready Control (This pin should be pulled high if not used.)	
\overline{AOE}	O	Output Enable	A
\overline{ARE}	O	Read Enable	A
\overline{AWE}	O	Write Enable	A
<i>Synchronous Memory Control</i>			
\overline{SRAS}	O	Row Address Strobe	A
\overline{SCAS}	O	Column Address Strobe	A
\overline{SWE}	O	Write Enable	A
SCKE	O	Clock Enable (Requires pull-down if hibernate is used.)	A
CLKOUT	O	Clock Output	B
SA10	O	A10 Pin	A
\overline{SMS}	O	Bank Select	A
<i>Timers</i>			
TMR0	I/O	Timer 0	C
TMR1/PPI_FS1	I/O	Timer 1/PPI Frame Sync1	C
TMR2/PPI_FS2	I/O	Timer 2/PPI Frame Sync2	C
<i>PPI Port</i>			
PPI3–0	I/O	PPI3–0	C
PPI_CLK/TMRCLK	I	PPI Clock/External Timer Reference	

ADSP-BF531/ADSP-BF532/ADSP-BF533

Table 9. Pin Descriptions (Continued)

Pin Name	Type	Function	Driver Type ¹
<i>Port F: GPIO/Parallel Peripheral Interface Port/SPI/Timers</i>			
PF0/ $\overline{\text{SPISS}}$	I/O	GPIO/SPI Slave Select Input	C
PF1/ $\overline{\text{SPISEL1/TACLK}}$	I/O	GPIO/SPI Slave Select Enable 1/Timer Alternate Clock Input	C
PF2/ $\overline{\text{SPISEL2}}$	I/O	GPIO/SPI Slave Select Enable 2	C
PF3/ $\overline{\text{SPISEL3/PPI_FS3}}$	I/O	GPIO/SPI Slave Select Enable 3/PPI Frame Sync 3	C
PF4/ $\overline{\text{SPISEL4/PPI15}}$	I/O	GPIO/SPI Slave Select Enable 4/PPI 15	C
PF5/ $\overline{\text{SPISEL5/PPI14}}$	I/O	GPIO/SPI Slave Select Enable 5/PPI 14	C
PF6/ $\overline{\text{SPISEL6/PPI13}}$	I/O	GPIO/SPI Slave Select Enable 6/PPI 13	C
PF7/ $\overline{\text{SPISEL7/PPI12}}$	I/O	GPIO/SPI Slave Select Enable 7/PPI 12	C
PF8/PPI11	I/O	GPIO/PPI 11	C
PF9/PPI10	I/O	GPIO/PPI 10	C
PF10/PPI9	I/O	GPIO/PPI 9	C
PF11/PPI8	I/O	GPIO/PPI 8	C
PF12/PPI7	I/O	GPIO/PPI 7	C
PF13/PPI6	I/O	GPIO/PPI 6	C
PF14/PPI5	I/O	GPIO/PPI 5	C
PF15/PPI4	I/O	GPIO/PPI 4	C
<i>JTAG Port</i>			
TCK	I	JTAG Clock	
TDO	O	JTAG Serial Data Out	C
TDI	I	JTAG Serial Data In	
TMS	I	JTAG Mode Select	
$\overline{\text{TRST}}$	I	JTAG Reset (This pin should be pulled low if JTAG is not used.)	
$\overline{\text{EMU}}$	O	Emulation Output	C
<i>SPI Port</i>			
MOSI	I/O	Master Out Slave In	C
MISO	I/O	Master In Slave Out (This pin should be pulled high through a 4.7 k Ω resistor if booting via the SPI port.)	C
SCK	I/O	SPI Clock	D
<i>Serial Ports</i>			
RSCLK0	I/O	SPORT0 Receive Serial Clock	D
RFS0	I/O	SPORT0 Receive Frame Sync	C
DR0PRI	I	SPORT0 Receive Data Primary	
DR0SEC	I	SPORT0 Receive Data Secondary	
TSCLK0	I/O	SPORT0 Transmit Serial Clock	D
TFS0	I/O	SPORT0 Transmit Frame Sync	C
DT0PRI	O	SPORT0 Transmit Data Primary	C
DT0SEC	O	SPORT0 Transmit Data Secondary	C
RSCLK1	I/O	SPORT1 Receive Serial Clock	D

ADSP-BF531/ADSP-BF532/ADSP-BF533

Table 9. Pin Descriptions (Continued)

Pin Name	Type	Function	Driver Type ¹
RFS1	I/O	SPORT1 Receive Frame Sync	C
DR1PRI	I	SPORT1 Receive Data Primary	
DR1SEC	I	SPORT1 Receive Data Secondary	
TSCLK1	I/O	SPORT1 Transmit Serial Clock	D
TFS1	I/O	SPORT1 Transmit Frame Sync	C
DT1PRI	O	SPORT1 Transmit Data Primary	C
DT1SEC	O	SPORT1 Transmit Data Secondary	C
<i>UART Port</i>			
RX	I	UART Receive	
TX	O	UART Transmit	C
<i>Real-Time Clock</i>			
RTXI	I	RTC Crystal Input (This pin should be pulled low when not used.)	
RTXO	O	RTC Crystal Output (Does not three-state in hibernate.)	
<i>Clock</i>			
CLKIN	I	Clock/Crystal Input (This pin needs to be at a level or clocking.)	
XTAL	O	Crystal Output	
<i>Mode Controls</i>			
$\overline{\text{RESET}}$	I	Reset (This pin is always active during core power-on.)	
NMI	I	Nonmaskable Interrupt (This pin should be pulled low when not used.)	
BMODE1-0	I	Boot Mode Strap (These pins must be pulled to the state required for the desired boot mode.)	
<i>Voltage Regulator</i>			
VROUT1-0	O	External FET Drive (These pins should be left unconnected when unused and are driven high during hibernate.)	
<i>Supplies</i>			
V _{DDEXT}	P	I/O Power Supply	
V _{DDINT}	P	Core Power Supply	
V _{DDRTC}	P	Real-Time Clock Power Supply (This pin should be connected to V _{DDEXT} when not used and should remain powered at all times.)	
GND	G	External Ground	

¹ Refer to [Figure 33 on Page 43](#) to [Figure 44 on Page 44](#).

ADSP-BF531/ADSP-BF532/ADSP-BF533

SPECIFICATIONS

Component specifications are subject to change without notice.

OPERATING CONDITIONS

Parameter	Conditions	Min	Nominal	Max	Unit
V _{DDINT} Internal Supply Voltage ¹	Nonautomotive 400 MHz and 500 MHz speed grade models ²	0.8	1.2	1.45	V
V _{DDINT} Internal Supply Voltage ¹	Nonautomotive 533 MHz speed grade models ²	0.8	1.25	1.45	V
V _{DDINT} Internal Supply Voltage ¹	600 MHz speed grade models ²	0.8	1.30	1.45	V
V _{DDINT} Internal Supply Voltage ¹	Automotive 400 MHz speed grade models ²	0.95	1.2	1.45	V
V _{DDINT} Internal Supply Voltage ¹	Automotive 533 MHz speed grade models ²	0.95	1.25	1.45	V
V _{DDEXT} External Supply Voltage ³	Nonautomotive grade models ²	1.75	1.8/3.3	3.6	V
V _{DDEXT} External Supply Voltage	Automotive grade models ²	2.7	3.3	3.6	V
V _{DDRTC} Real-Time Clock Power Supply Voltage	Nonautomotive grade models ²	1.75	1.8/3.3	3.6	V
V _{DDRTC} Real-Time Clock Power Supply Voltage	Automotive grade models ²	2.7	3.3	3.6	V
V _{IH} High Level Input Voltage ^{4,5}	V _{DDEXT} = 1.85 V	1.3			V
V _{IH} High Level Input Voltage ^{4,5}	V _{DDEXT} = Maximum	2.0			V
V _{IHCLKIN} High Level Input Voltage ⁶	V _{DDEXT} = Maximum	2.2			V
V _{IL} Low Level Input Voltage ⁷	V _{DDEXT} = 1.75 V			+0.3	V
V _{IL} Low Level Input Voltage ⁷	V _{DDEXT} = 2.7 V			+0.6	V
T _J Junction Temperature	160-Ball Chip Scale Ball Grid Array (CSP_BGA) @ T _{AMBIENT} = 0°C to +70°C	0		+95	°C
T _J Junction Temperature	160-Ball Chip Scale Ball Grid Array (CSP_BGA) @ T _{AMBIENT} = -40°C to +85°C	-40		+105	°C
T _J Junction Temperature	160-Ball Chip Scale Ball Grid Array (CSP_BGA) @ T _{AMBIENT} = -40°C to +105°C	-40		+125	°C
T _J Junction Temperature	169-Ball Plastic Ball Grid Array (PBGA) @ T _{AMBIENT} = -40°C to +105°C	-40		+125	°C
T _J Junction Temperature	169-Ball Plastic Ball Grid Array (PBGA) @ T _{AMBIENT} = -40°C to +85°C	-40		+105	°C
T _J Junction Temperature	176-Lead Quad Flatpack (LQFP) @ T _{AMBIENT} = -40°C to +85°C	-40		+100	°C

¹ The regulator can generate V_{DDINT} at levels of 0.85 V to 1.2 V with -5% to +10% tolerance, 1.25 V with -4% to +10% tolerance, and 1.3 V with -0% to +10% tolerance.

² See [Ordering Guide on Page 63](#).

³ When V_{DDEXT} < 2.25 V, on-chip voltage regulation is not supported.

⁴ Applies to all input and bidirectional pins except CLKIN.

⁵ The ADSP-BF531/ADSP-BF532/ADSP-BF533 processors are 3.3 V tolerant (always accepts up to 3.6 V maximum V_{IH}), but voltage compliance (on outputs, V_{OH}) depends on the input V_{DDEXT}, because V_{OH} (maximum) approximately equals V_{DDEXT} (maximum). This 3.3 V tolerance applies to bidirectional pins (DATA15-0, TMR2-0, PF15-0, PPI3-0, RSCLK1-0, TSCLK1-0, RFS1-0, TFS1-0, MOSI, MISO, SCK) and input only pins ($\overline{\text{BR}}$, ARDY, PPI_CLK, DR0PRI, DR0SEC, DR1PRI, DR1SEC, RX, RTXI, TCK, TDI, TMS, TRST, CLKIN, RESET, NMI, and BMODE1-0).

⁶ Applies to CLKIN pin only.

⁷ Applies to all input and bidirectional pins.

ADSP-BF531/ADSP-BF532/ADSP-BF533

The following three tables describe the voltage/frequency requirements for the processor clocks. Take care in selecting MSEL, SSEL, and CSEL ratios so as not to exceed the maximum

core clock (Table 10 and Table 11) and system clock (Table 13) specifications. Table 12 describes phase-locked loop operating conditions.

Table 10. Core Clock (CCLK) Requirements—500 MHz, 533 MHz, and 600 MHz Models

Parameter	Internal Regulator Setting	Max	Unit
f_{CCLK} CCLK Frequency ($V_{\text{DDINT}} = 1.3 \text{ V}$ Minimum) ¹	1.30 V	600	MHz
f_{CCLK} CCLK Frequency ($V_{\text{DDINT}} = 1.2 \text{ V}$ Minimum) ²	1.25 V	533	MHz
f_{CCLK} CCLK Frequency ($V_{\text{DDINT}} = 1.14 \text{ V}$ Minimum) ³	1.20 V	500	MHz
f_{CCLK} CCLK Frequency ($V_{\text{DDINT}} = 1.045 \text{ V}$ Minimum)	1.10 V	444	MHz
f_{CCLK} CCLK Frequency ($V_{\text{DDINT}} = 0.95 \text{ V}$ Minimum)	1.00 V	400	MHz
f_{CCLK} CCLK Frequency ($V_{\text{DDINT}} = 0.85 \text{ V}$ Minimum)	0.90 V	333	MHz
f_{CCLK} CCLK Frequency ($V_{\text{DDINT}} = 0.8 \text{ V}$ Minimum)	0.85 V	250	MHz

¹ Applies to 600 MHz models only. See [Ordering Guide on Page 63](#).

² Applies to 533 MHz and 600 MHz models only. See [Ordering Guide on Page 63](#). 533 MHz models cannot support internal regulator levels above 1.25 V.

³ Applies to 500 MHz, 533 MHz, and 600 MHz models. See [Ordering Guide on Page 63](#). 500 MHz models cannot support internal regulator levels above 1.20 V.

Table 11. Core Clock (CCLK) Requirements—400 MHz Models¹

Parameter	Internal Regulator Setting	$T_j = 125^\circ\text{C}$	All ² Other T_j	Unit
		Max	Max	
f_{CCLK} CCLK Frequency ($V_{\text{DDINT}} = 1.14 \text{ V}$ Minimum)	1.20 V	400	400	MHz
f_{CCLK} CCLK Frequency ($V_{\text{DDINT}} = 1.045 \text{ V}$ Minimum)	1.10 V	333	364	MHz
f_{CCLK} CCLK Frequency ($V_{\text{DDINT}} = 0.95 \text{ V}$ Minimum)	1.00 V	295	333	MHz
f_{CCLK} CCLK Frequency ($V_{\text{DDINT}} = 0.85 \text{ V}$ Minimum)	0.90 V		280	MHz
f_{CCLK} CCLK Frequency ($V_{\text{DDINT}} = 0.8 \text{ V}$ Minimum)	0.85 V		250	MHz

¹ See [Ordering Guide on Page 63](#).

² See [Operating Conditions on Page 20](#).

Table 12. Phase-Locked Loop Operating Conditions

Parameter	Min	Max	Unit
f_{VCO} Voltage Controlled Oscillator (VCO) Frequency	50	Max f_{CCLK}	MHz

Table 13. System Clock (SCLK) Requirements

Parameter ¹	$V_{\text{DDEXT}} = 1.8 \text{ V}$	$V_{\text{DDEXT}} = 2.5 \text{ V}/3.3 \text{ V}$	Unit
	Max	Max	
CSP_BGA/PBGA			
f_{SCLK} CLKOUT/SCLK Frequency ($V_{\text{DDINT}} \geq 1.14 \text{ V}$)	100	133	MHz
f_{SCLK} CLKOUT/SCLK Frequency ($V_{\text{DDINT}} < 1.14 \text{ V}$)	100	100	MHz
LQFP			
f_{SCLK} CLKOUT/SCLK Frequency ($V_{\text{DDINT}} \geq 1.14 \text{ V}$)	100	133	MHz
f_{SCLK} CLKOUT/SCLK Frequency ($V_{\text{DDINT}} < 1.14 \text{ V}$)	83	83	MHz

¹ $t_{\text{SCLK}} (= 1/f_{\text{SCLK}})$ must be greater than or equal to t_{CCLK} .

ADSP-BF531/ADSP-BF532/ADSP-BF533

ELECTRICAL CHARACTERISTICS

Parameter	Test Conditions	400 MHz ¹			500 MHz/533 MHz/600 MHz ²			Unit	
		Min	Typical	Max	Min	Typical	Max		
V _{OH}	High Level Output Voltage ³	V _{DDEXT} = 1.75 V, I _{OH} = -0.5 mA	1.5			1.5		V	
		V _{DDEXT} = 2.25 V, I _{OH} = -0.5 mA	1.9			1.9		V	
		V _{DDEXT} = 3.0 V, I _{OH} = -0.5 mA	2.4			2.4		V	
V _{OL}	Low Level Output Voltage ³	V _{DDEXT} = 1.75 V, I _{OL} = 2.0 mA					0.2	V	
		V _{DDEXT} = 2.25 V/3.0 V, I _{OL} = 2.0 mA					0.4	V	
I _{IH}	High Level Input Current ⁴	V _{DDEXT} = Max, V _{IN} = V _{DD} Max					10.0	μA	
I _{IHP}	High Level Input Current JTAG ⁵	V _{DDEXT} = Max, V _{IN} = V _{DD} Max					50.0	μA	
I _{IL} ⁶	Low Level Input Current ⁴	V _{DDEXT} = Max, V _{IN} = 0 V					10.0	μA	
I _{OZH}	Three-State Leakage Current ⁷	V _{DDEXT} = Max, V _{IN} = V _{DD} Max					10.0	μA	
I _{OZL} ⁶	Three-State Leakage Current ⁷	V _{DDEXT} = Max, V _{IN} = 0 V					10.0	μA	
C _{IN}	Input Capacitance ⁸	f _{IN} = 1 MHz, T _{AMBIENT} = 25°C, V _{IN} = 2.5 V	4		8 ⁹		4	8 ⁹	pF
I _{DDDEEPSLEEP} ¹⁰	V _{DDINT} Current in Deep Sleep Mode	V _{DDINT} = 1.0 V, f _{CLK} = 0 MHz, T _J = 25°C, ASF = 0.00		7.5			32.5		mA
I _{DDSLEEP}	V _{DDINT} Current in Sleep Mode	V _{DDINT} = 0.8 V, T _J = 25°C, SCLK = 25 MHz			10			37.5	mA
I _{DD-TYP} ¹¹	V _{DDINT} Current	V _{DDINT} = 1.14 V, f _{CLK} = 400 MHz, T _J = 25°C		125			152		mA
I _{DD-TYP} ¹¹	V _{DDINT} Current	V _{DDINT} = 1.2 V, f _{CLK} = 500 MHz, T _J = 25°C					190		mA
I _{DD-TYP} ¹¹	V _{DDINT} Current	V _{DDINT} = 1.2 V, f _{CLK} = 533 MHz, T _J = 25°C					200		mA
I _{DD-TYP} ¹¹	V _{DDINT} Current	V _{DDINT} = 1.3 V, f _{CLK} = 600 MHz, T _J = 25°C					245		mA
I _{DDHIBERNATE} ¹⁰	V _{DDEXT} Current in Hibernate State	V _{DDEXT} = 3.6 V, CLKIN = 0 MHz, T _J = Max, voltage regulator off (V _{DDINT} = 0 V)	50	100			50	100	μA
I _{DDRTC}	V _{DDRTC} Current	V _{DDRTC} = 3.3 V, T _J = 25°C		20			20		μA
I _{DDDEEPSLEEP} ¹⁰	V _{DDINT} Current in Deep Sleep Mode	f _{CLK} = 0 MHz	6		Table 15		16	Table 14	mA
I _{DD-INT}	V _{DDINT} Current	f _{CLK} > 0 MHz			I _{DDDEEPSLEEP} + (Table 17 × ASF)			I _{DDDEEPSLEEP} + (Table 17 × ASF)	mA

¹ Applies to all 400 MHz speed grade models. See [Ordering Guide on Page 63](#).

² Applies to all 500 MHz, 533 MHz, and 600 MHz speed grade models. See [Ordering Guide on Page 63](#).

³ Applies to output and bidirectional pins.

⁴ Applies to input pins except JTAG inputs.

ADSP-BF531/ADSP-BF532/ADSP-BF533

⁵ Applies to JTAG input pins (TCK, TDI, TMS, $\overline{\text{TRST}}$).

⁶ Absolute value.

⁷ Applies to three-statable pins.

⁸ Applies to all signal pins.

⁹ Guaranteed, but not tested.

¹⁰ See the *ADSP-BF533 Blackfin Processor Hardware Reference Manual* for definitions of sleep, deep sleep, and hibernate operating modes.

¹¹ See [Table 16](#) for the list of I_{DDINT} power vectors covered by various Activity Scaling Factors (ASF).

System designers should refer to *Estimating Power for the ADSP-BF531/BF532/BF533 Blackfin Processors (EE-229)*, which provides detailed information for optimizing designs for lowest power. All topics discussed in this section are described in detail in EE-229. Total power dissipation has two components:

1. Static, including leakage current
2. Dynamic, due to transistor switching characteristics

Many operating conditions can also affect power dissipation, including temperature, voltage, operating frequency, and processor activity. [Electrical Characteristics on Page 22](#) shows the

current dissipation for internal circuitry (V_{DDINT}). $I_{\text{DDDEEPSLEEP}}$ specifies static power dissipation as a function of voltage (V_{DDINT}) and temperature (see [Table 14](#) or [Table 15](#)), and I_{DDINT} specifies the total power specification for the listed test conditions, including the dynamic component as a function of voltage (V_{DDINT}) and frequency ([Table 17](#)).

The dynamic component is also subject to an Activity Scaling Factor (ASF) which represents application code running on the processor ([Table 16](#)).

Table 14. Static Current—500 MHz, 533 MHz, and 600 MHz Speed Grade Devices (mA)¹

T_J (°C) ²	Voltage (V_{DDINT}) ²														
	0.80 V	0.85 V	0.90 V	0.95 V	1.00 V	1.05 V	1.10 V	1.15 V	1.20 V	1.25 V	1.30 V	1.32 V	1.375 V	1.43 V	1.45 V
-45	4.3	5.3	5.9	7.0	8.2	9.8	11.2	13.0	15.2	17.7	20.2	21.6	25.5	30.1	32.0
0	18.8	21.3	24.1	27.8	31.6	35.6	40.1	45.3	51.4	58.1	65.0	68.5	78.4	89.8	94.3
25	35.3	39.9	45.0	50.9	57.3	64.4	72.9	80.9	90.3	101.4	112.1	118.0	133.7	151.6	158.7
40	52.3	58.5	65.1	73.3	81.3	90.9	101.2	112.5	125.5	138.7	154.4	160.6	180.6	203.1	212.0
55	73.6	82.5	92.0	102.7	114.4	126.3	141.2	155.7	172.7	191.1	212.1	220.8	247.6	277.7	289.5
70	100.8	112.5	124.5	137.4	152.6	168.4	186.5	205.4	227.0	250.3	276.2	287.1	320.4	357.4	371.9
85	133.3	148.5	164.2	180.5	198.8	219.0	241.0	264.5	290.6	319.7	350.2	364.6	404.9	449.7	467.2
100	178.3	196.3	216.0	237.6	259.9	284.6	311.9	342.0	373.1	408.0	446.1	462.6	511.1	564.7	585.6
115	223.3	245.9	270.2	295.7	323.5	353.3	386.1	421.1	460.1	500.9	545.0	566.5	624.3	688.1	712.8
125	278.5	305.8	334.1	364.3	397.4	432.4	470.6	509.3	553.4	600.6	652.1	676.5	742.1	814.1	841.9

¹ Values are guaranteed maximum $I_{\text{DDDEEPSLEEP}}$ specifications.

² Valid temperature and voltage ranges are model-specific. See [Operating Conditions on Page 20](#).

Table 15. Static Current—400 MHz Speed Grade Devices (mA)¹

T_J (°C) ²	Voltage (V_{DDINT}) ²											
	0.80 V	0.85 V	0.90 V	0.95 V	1.00 V	1.05 V	1.10 V	1.15 V	1.20 V	1.25 V	1.30 V	1.32 V
-45	0.9	1.1	1.3	1.5	1.8	2.2	2.6	3.1	3.8	4.4	5.0	5.4
0	3.3	3.7	4.2	4.8	5.5	6.3	7.2	8.1	8.9	10.1	11.2	11.9
25	7.5	8.4	9.4	10.0	11.2	12.6	14.1	15.5	17.2	19.0	21.2	21.9
40	12.0	13.1	14.3	15.9	17.4	19.4	21.5	23.5	25.8	28.1	30.8	32.0
55	18.3	20.0	21.9	23.6	26.0	28.2	30.8	33.7	36.8	39.8	43.4	45.0
70	27.7	30.3	32.6	35.3	38.2	41.7	45.2	49.0	52.8	57.6	62.4	64.2
85	38.2	41.7	44.9	48.6	52.7	57.3	61.7	66.7	72.0	77.5	83.9	86.5
100	54.1	58.1	63.2	67.8	73.2	78.8	84.9	91.5	98.4	106.0	113.8	117.2
115	73.9	80.0	86.3	91.9	99.1	106.6	114.1	122.4	131.1	140.9	151.1	155.5
125	98.7	106.3	113.8	122.1	130.8	140.2	149.7	160.4	171.9	183.8	197.0	202.4

¹ Values are guaranteed maximum $I_{\text{DDDEEPSLEEP}}$ specifications.

² Valid temperature and voltage ranges are model-specific. See [Operating Conditions on Page 20](#).

ADSP-BF531/ADSP-BF532/ADSP-BF533

Table 16. Activity Scaling Factors

I_{DDINT} Power Vector¹	Activity Scaling Factor (ASF)²
I _{DD-PEAK}	1.27
I _{DD-HIGH}	1.25
I _{DD-TYP}	1.00
I _{DD-APP}	0.86
I _{DD-NOP}	0.72
I _{DD-IDLE}	0.41

¹ See EE-229 for power vector definitions.

² All ASF values determined using a 10:1 CCLK:SCLK ratio.

Table 17. Dynamic Current (mA, with ASF = 1.0)¹

Frequency (MHz)²	Voltage (V_{DDINT})²														
	0.80 V	0.85 V	0.90 V	0.95 V	1.00 V	1.05 V	1.10 V	1.15 V	1.20 V	1.25 V	1.30 V	1.32 V	1.375 V	1.43 V	1.45 V
50	12.7	13.9	15.3	16.8	18.1	19.4	21.0	22.3	24.0	25.4	26.4	27.2	28.7	30.3	30.7
100	22.6	24.2	26.2	28.1	30.1	31.8	34.7	36.2	38.4	40.5	43.0	43.4	45.7	47.9	48.9
200	40.8	44.1	46.9	50.3	53.3	56.9	59.9	63.1	66.7	70.2	73.8	75.0	78.7	82.4	84.6
250	50.1	53.8	57.2	61.4	64.7	68.9	72.9	76.8	81.0	85.1	89.3	90.8	95.2	99.6	102.0
300	N/A	63.5	67.4	72.4	76.2	81.0	85.9	90.6	95.2	100.0	104.8	106.6	111.8	116.9	119.4
375	N/A	N/A	N/A	88.6	93.5	99.0	104.6	110.3	116.0	122.1	128.0	130.0	136.2	142.4	145.5
400	N/A	N/A	N/A	93.9	99.3	105.0	110.8	116.8	123.0	129.4	135.7	137.9	144.6	151.2	154.3
425	N/A	N/A	N/A	N/A	N/A	111.0	117.3	123.5	129.9	136.8	143.2	145.6	152.6	159.7	162.8
475	N/A	N/A	N/A	N/A	N/A	N/A	130.3	136.8	143.8	151.4	158.1	161.1	168.9	176.6	179.7
500	N/A	N/A	N/A	N/A	N/A	N/A	N/A	143.5	150.7	158.7	165.6	168.8	177.0	185.2	188.2
533	N/A	N/A	N/A	N/A	N/A	N/A	N/A	N/A	160.4	168.8	176.5	179.6	188.2	196.8	200.5
600	N/A	N/A	N/A	N/A	N/A	N/A	N/A	N/A	N/A	N/A	196.2	199.6	209.3	219.0	222.6

¹ The values are not guaranteed as stand-alone maximum specifications, they must be combined with static current per the equations of [Electrical Characteristics on Page 22](#).

² Valid temperature and voltage ranges are model-specific. See [Operating Conditions on Page 20](#).

ABSOLUTE MAXIMUM RATINGS

Stresses greater than those listed in [Table 18](#) may cause permanent damage to the device. These are stress ratings only. Functional operation of the device at these or any other conditions greater than those indicated in the operational sections of this specification is not implied. Exposure to absolute maximum rating conditions for extended periods can affect device reliability.

Table 18. Absolute Maximum Ratings

Parameter	Rating
Internal (Core) Supply Voltage (V_{DDINT})	-0.3 V to +1.45 V
External (I/O) Supply Voltage (V_{DDEXT})	-0.5 V to +3.8 V
Input Voltage ^{1, 2}	-0.5 V to +3.8 V
Output Voltage Swing	-0.5 V to $V_{DDEXT} + 0.5$ V
Storage Temperature Range	-65°C to +150°C
Junction Temperature While Biased	125°C

¹ Applies to 100% transient duty cycle. For other duty cycles see [Table 19](#).

² Applies only when V_{DDEXT} is within specifications. When V_{DDEXT} is outside specifications, the range is $V_{DDEXT} \pm 0.2$ V.

Table 19. Maximum Duty Cycle for Input Transient Voltage¹

V_{IN} Min (V) ²	V_{IN} Max (V) ²	Maximum Duty Cycle ³
-0.50	+3.80	100%
-0.70	+4.00	40%
-0.80	+4.10	25%
-0.90	+4.20	15%
-1.00	+4.30	10%

¹ Applies to all signal pins with the exception of CLKIN, XTAL, VROUT1-0.

² The individual values cannot be combined for analysis of a single instance of overshoot or undershoot. The worst case observed value must fall within one of the voltages specified and the total duration of the overshoot or undershoot (exceeding the 100% case) must be less than or equal to the corresponding duty cycle.

³ Duty cycle refers to the percentage of time the signal exceeds the value for the 100% case. This is equivalent to the measured duration of a single instance of overshoot or undershoot as a percentage of the period of occurrence.

ESD SENSITIVITY



ESD (electrostatic discharge) sensitive device.

Charged devices and circuit boards can discharge without detection. Although this product features patented or proprietary protection circuitry, damage may occur on devices subjected to high energy ESD. Therefore, proper ESD precautions should be taken to avoid performance degradation or loss of functionality.

ADSP-BF531/ADSP-BF532/ADSP-BF533

PACKAGE INFORMATION

The information presented in [Figure 10](#) and [Table 20](#) provides details about the package branding for the Blackfin processors. For a complete listing of product availability, see the [Ordering Guide on Page 63](#).



Figure 10. Product Information on Package

Table 20. Package Brand Information¹

Brand Key	Field Description
ADSP-BF53x	Either ADSP-BF531, ADSP-BF532, or ADSP-BF533
t	Temperature Range
pp	Package Type
Z	RoHS Compliant Part
ccc	See Ordering Guide
vvvvv.x	Assembly Lot Code
n.n	Silicon Revision
#	RoHS Compliant Designation
yyww	Date Code

¹ Non Automotive only. For branding information specific to Automotive products, contact Analog Devices Inc.

TIMING SPECIFICATIONS

Clock and Reset Timing

Table 21 and Figure 11 describe clock and reset operations. Per Absolute Maximum Ratings on Page 25, combinations of CLKIN and clock multipliers/divisors must not result in core/

system clocks exceeding the maximum limits allowed for the processor, including system clock restrictions related to supply voltage.

Table 21. Clock and Reset Timing

Parameter	Min	Max	Unit
<i>Timing Requirements</i>			
t_{CKIN} CLKIN Period ^{1, 2, 3, 4}	25.0	100.0	ns
t_{CKINL} CLKIN Low Pulse	10.0		ns
t_{CKINH} CLKIN High Pulse	10.0		ns
t_{WRST} \overline{RESET} Asserted Pulse Width Low ⁵	$11 \times t_{CKIN}$		ns
t_{NOBOOT} \overline{RESET} Deassertion to First External Access Delay ⁶	$3 \times t_{CKIN}$	$5 \times t_{CKIN}$	ns

¹ Applies to PLL bypass mode and PLL non bypass mode.

² CLKIN frequency must not change on the fly.

³ Combinations of the CLKIN frequency and the PLL clock multiplier must not exceed the allowed f_{VCO} , f_{CLK} , and f_{SCLK} settings discussed in Table 11 on Page 21 through Table 13 on Page 21. Since the default behavior of the PLL is to multiply the CLKIN frequency by 10, the 400 MHz speed grade parts cannot use the full CLKIN period range.

⁴ If the DF bit in the PLL_CTL register is set, then the maximum t_{CKIN} period is 50 ns.

⁵ Applies after power-up sequence is complete. See Table 22 and Figure 12 for power-up reset timing.

⁶ Applies when processor is configured in No Boot Mode (BMODE1-0 = b#00).

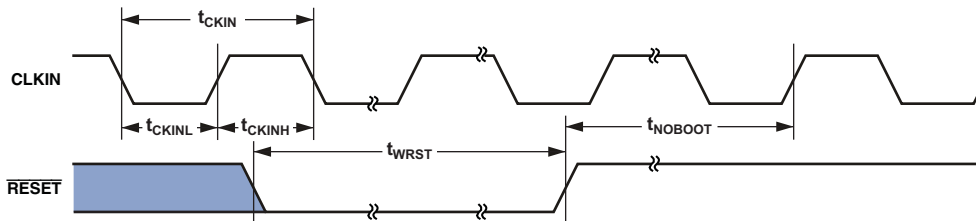
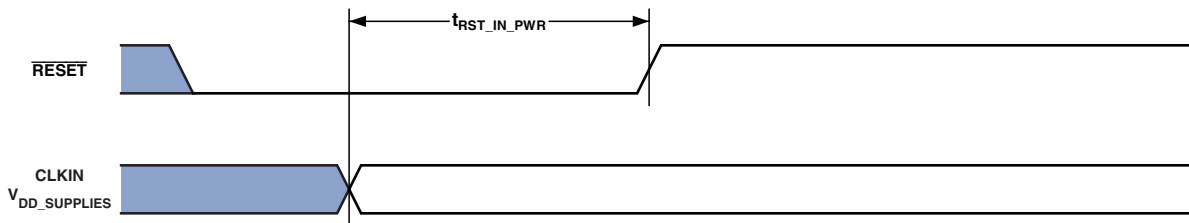

Figure 11. Clock and Reset Timing

Table 22. Power-Up Reset Timing

Parameter	Min	Max	Unit
<i>Timing Requirement</i>			
$t_{RST_IN_PWR}$ \overline{RESET} Deasserted After the V_{DDINT} , V_{DDEXT} , V_{DDRTC} , and CLKIN Pins Are Stable and Within Specification	$3500 \times t_{CKIN}$		ns



In Figure 12, $V_{DD_SUPPLIES}$ is V_{DDINT} , V_{DDEXT} , V_{DDRTC}

Figure 12. Power-Up Reset Timing

ADSP-BF531/ADSP-BF532/ADSP-BF533

Asynchronous Memory Read Cycle Timing

Table 23. Asynchronous Memory Read Cycle Timing

Parameter	$V_{DDEXT} = 1.8\text{ V}$		$V_{DDEXT} = 2.5\text{ V}/3.3\text{ V}$		Unit
	Min	Max	Min	Max	
<i>Timing Requirements</i>					
t_{SDAT}	DATA15–0 Setup Before CLKOUT		2.1	2.1	ns
t_{HDAT}	DATA15–0 Hold After CLKOUT		1.0	0.8	ns
t_{SARDY}	ARDY Setup Before CLKOUT		4.0	4.0	ns
t_{HARDY}	ARDY Hold After CLKOUT		1.0	0.0	ns
<i>Switching Characteristics</i>					
t_{DO}	Output Delay After CLKOUT ¹		1.0	6.0	ns
t_{HO}	Output Hold After CLKOUT ¹		1.0	0.8	ns

¹ Output pins include $\overline{AMS3-0}$, $\overline{ABE1-0}$, $\overline{ADDR19-1}$, $\overline{DATA15-0}$, \overline{AOE} , \overline{ARE} .

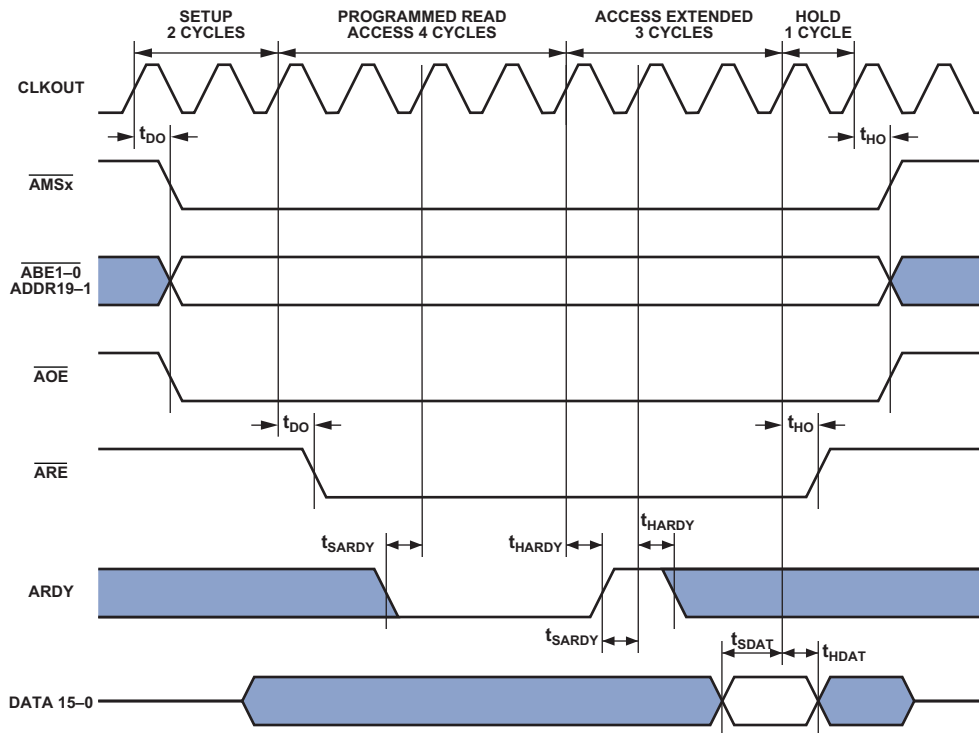

Figure 13. Asynchronous Memory Read Cycle Timing

ADSP-BF531/ADSP-BF532/ADSP-BF533

Asynchronous Memory Write Cycle Timing

Table 24. Asynchronous Memory Write Cycle Timing

Parameter	$V_{DDEXT} = 1.8\text{ V}$		$V_{DDEXT} = 2.5\text{ V}/3.3\text{ V}$		Unit
	Min	Max	Min	Max	
<i>Timing Requirements</i>					
t_{SARDY} ARDY Setup Before CLKOUT	4.0		4.0		ns
t_{HARDY} ARDY Hold After CLKOUT	1.0		0.0		ns
<i>Switching Characteristics</i>					
t_{DDAT} DATA15-0 Disable After CLKOUT		6.0		6.0	ns
t_{ENDAT} DATA15-0 Enable After CLKOUT	1.0		1.0		ns
t_{DO} Output Delay After CLKOUT ¹		6.0		6.0	ns
t_{HO} Output Hold After CLKOUT ¹	1.0		0.8		ns

¹ Output pins include $\overline{AMS3-0}$, $\overline{ABE1-0}$, $\overline{ADDR19-1}$, $\overline{DATA15-0}$, \overline{AOE} , \overline{AWE} .



Figure 14. Asynchronous Memory Write Cycle Timing

ADSP-BF531/ADSP-BF532/ADSP-BF533

SDRAM Interface Timing

Table 25. SDRAM Interface Timing¹

Parameter	$V_{DDEXT} = 1.8\text{ V}$		$V_{DDEXT} = 2.5\text{ V}/3.3\text{ V}$		Unit
	Min	Max	Min	Max	
<i>Timing Requirements</i>					
t_{SSDAT} DATA Setup Before CLKOUT	2.1		1.5		ns
t_{HSDAT} DATA Hold After CLKOUT	0.8		0.8		ns
<i>Switching Characteristics</i>					
t_{DCAD} Command, ADDR, Data Delay After CLKOUT ²		6.0		4.0	ns
t_{HCAD} Command, ADDR, Data Hold After CLKOUT ²	1.0		1.0		ns
t_{DSDAT} Data Disable After CLKOUT		6.0		4.0	ns
t_{ENSDAT} Data Enable After CLKOUT	1.0		1.0		ns
t_{SCLK} CLKOUT Period ³	10.0		7.5		ns
t_{SCLKH} CLKOUT Width High	2.5		2.5		ns
t_{SCLKL} CLKOUT Width Low	2.5		2.5		ns

¹ SDRAM timing for $T_j > 105^\circ\text{C}$ is limited to 100 MHz.

² Command pins include: $\overline{\text{SRAS}}$, $\overline{\text{SCAS}}$, $\overline{\text{SWE}}$, $\overline{\text{SDQM}}$, $\overline{\text{SMS}}$, SA10, $\overline{\text{SCKE}}$.

³ Refer to Table 13 on Page 21 for maximum f_{SCLK} at various V_{DDINT} .

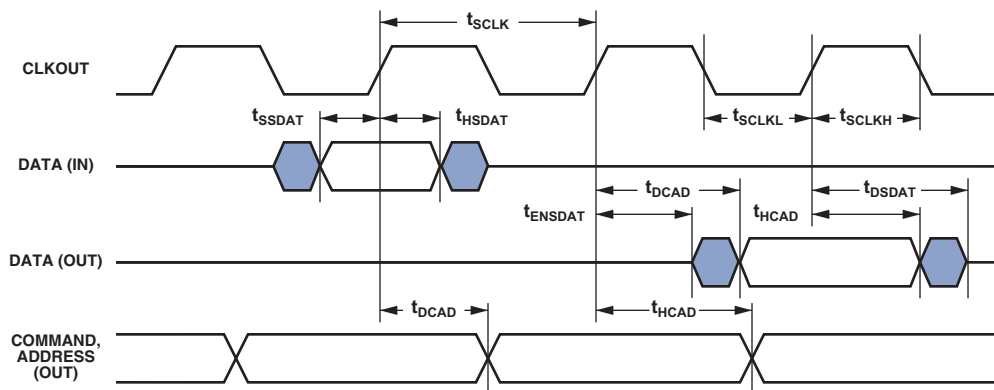

NOTE: COMMAND = $\overline{\text{SRAS}}$, $\overline{\text{SCAS}}$, $\overline{\text{SWE}}$, $\overline{\text{SDQM}}$, $\overline{\text{SMS}}$, SA10, $\overline{\text{SCKE}}$.

Figure 15. SDRAM Interface Timing

ADSP-BF531/ADSP-BF532/ADSP-BF533

External Port Bus Request and Grant Cycle Timing

Table 26 and Figure 16 describe external port bus request and bus grant operations.

Table 26. External Port Bus Request and Grant Cycle Timing

Parameter	$V_{DDEXT} = 1.8\text{ V}$ LQFP/PBGA Packages		$V_{DDEXT} = 1.8\text{ V}$ CSP_BGA Package		$V_{DDEXT} = 2.5\text{ V}/3.3\text{ V}$ All Packages		Unit
	Min	Max	Min	Max	Min	Max	
<i>Timing Requirements</i>							
t_{BS} \overline{BR} Asserted to CLKOUT High Setup	4.6		4.6		4.6		ns
t_{BH} CLKOUT High to \overline{BR} Deasserted Hold Time	1.0		1.0		0.0		ns
<i>Switching Characteristics</i>							
t_{SD} CLKOUT Low to \overline{AMSx} , Address, and $\overline{ARE}/\overline{AWE}$ Disable		4.5		4.5		4.5	ns
t_{SE} CLKOUT Low to \overline{AMSx} , Address, and $\overline{ARE}/\overline{AWE}$ Enable		4.5		4.5		4.5	ns
t_{DBG} CLKOUT High to \overline{BG} High Setup		6.0		5.5		3.6	ns
t_{EBG} CLKOUT High to \overline{BG} Deasserted Hold Time		6.0		4.6		3.6	ns
t_{DBH} CLKOUT High to \overline{BGH} High Setup		6.0		5.5		3.6	ns
t_{EBH} CLKOUT High to \overline{BGH} Deasserted Hold Time		6.0		4.6		3.6	ns

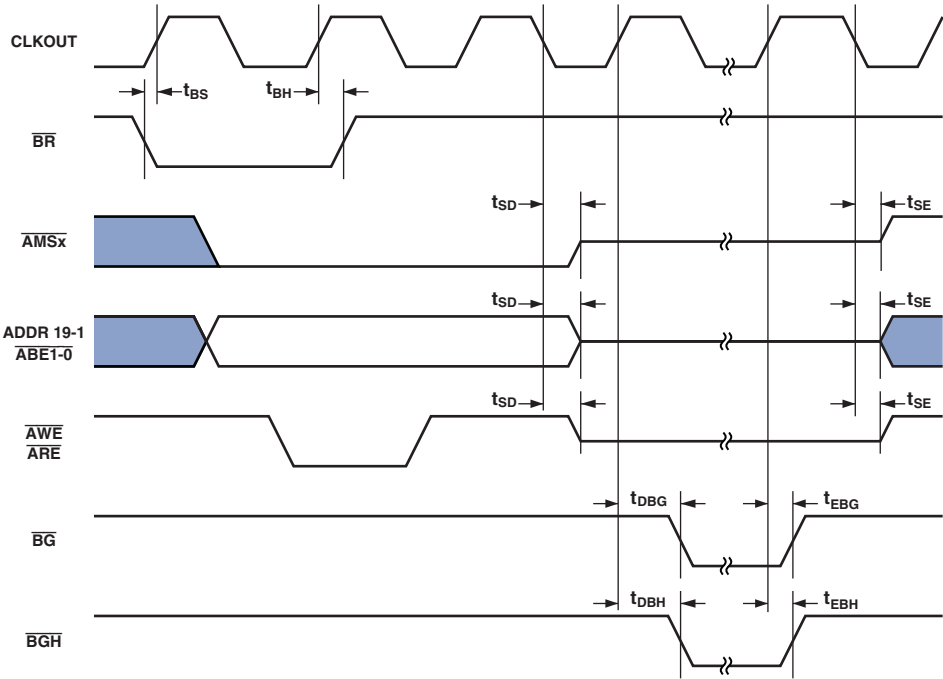

Figure 16. External Port Bus Request and Grant Cycle Timing

ADSP-BF531/ADSP-BF532/ADSP-BF533

Parallel Peripheral Interface Timing

Table 27 and Figure 17 through Figure 22 describe parallel peripheral interface operations.

Table 27. Parallel Peripheral Interface Timing

Parameter	$V_{DDEXT} = 1.8\text{ V}$ LQFP/PBGA Packages		$V_{DDEXT} = 1.8\text{ V}$ CSP_BGA Package		$V_{DDEXT} = 2.5\text{ V}/3.3\text{ V}$ All Packages		Unit
	Min	Max	Min	Max	Min	Max	
<i>Timing Requirements</i>							
t_{PCLKW} PPI_CLK Width	8.0		8.0		6.0		ns
t_{PCLK} PPI_CLK Period ¹	20.0		20.0		15.0		ns
t_{SFSPe} External Frame Sync Setup Before PPI_CLK Edge (Nonsampling Edge for Rx, Sampling Edge for Tx)	6.0		6.0		4.0 ²		ns
t_{HFSPe} External Frame Sync Hold After PPI_CLK	1.0 ²		1.0 ²		1.0 ²		ns
t_{SDRPe} Receive Data Setup Before PPI_CLK	3.5		3.5		3.5		ns
t_{HDRPe} Receive Data Hold After PPI_CLK	1.5		1.5		1.5		ns
<i>Switching Characteristics—GP Output and Frame Capture Modes</i>							
t_{DFSPe} Internal Frame Sync Delay After PPI_CLK		11.0		8.0		8.0	ns
t_{HOFSPe} Internal Frame Sync Hold After PPI_CLK	1.7		1.7		1.7		ns
t_{DDTPe} Transmit Data Delay After PPI_CLK		11.0		9.0		9.0	ns
t_{HDTPe} Transmit Data Hold After PPI_CLK	1.8		1.8		1.8		ns

¹ PPI_CLK frequency cannot exceed $f_{SCLK}/2$.

² Applies when PPI_CONTROL Bit 8 is cleared. See Figure 19 and Figure 22.

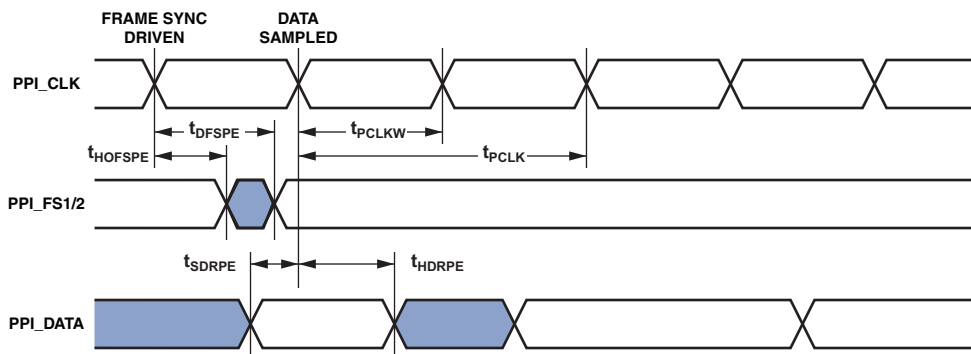

Figure 17. PPI GP Rx Mode with Internal Frame Sync Timing

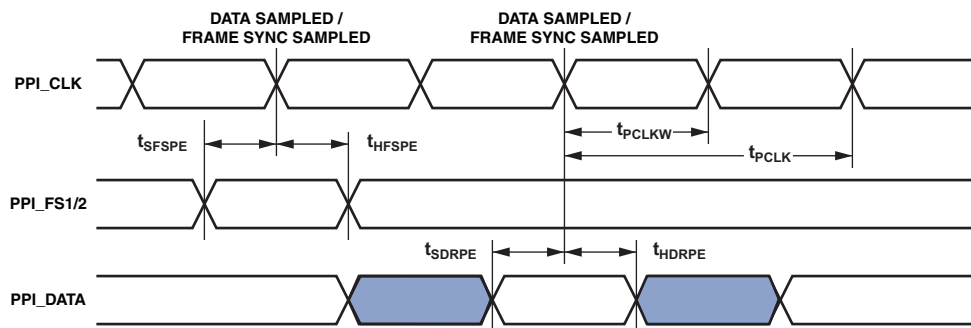

Figure 18. PPI GP Rx Mode with External Frame Sync Timing (PPI_CONTROL Bit 8 = 1)

ADSP-BF531/ADSP-BF532/ADSP-BF533



Figure 19. PPI GP Rx Mode with External Frame Sync Timing (PPI_CONTROL Bit 8 = 0)



Figure 20. PPI GP Tx Mode with Internal Frame Sync Timing



Figure 21. PPI GP Tx Mode with External Frame Sync Timing (PPI_CONTROL Bit 8 = 1)



Figure 22. PPI GP Tx Mode with External Frame Sync Timing (PPI_CONTROL Bit 8 = 0)

ADSP-BF531/ADSP-BF532/ADSP-BF533

Serial Port Timing

Table 28 through Table 31 on Page 37 and Figure 23 on Page 35 through Figure 26 on Page 37 describe Serial Port operations.

Table 28. Serial Ports—External Clock

Parameter	V _{DDEXT} = 1.8 V		V _{DDEXT} = 2.5 V/3.3 V		Unit
	Min	Max	Min	Max	
<i>Timing Requirements</i>					
t _{SFSE} TFSx/RFSx Setup Before TSCLKx/RSCLKx ¹	3.0		3.0		ns
t _{HFSE} TFSx/RFSx Hold After TSCLKx/RSCLKx ¹	3.0		3.0		ns
t _{SDRE} Receive Data Setup Before RSCLKx ¹	3.0		3.0		ns
t _{HDRE} Receive Data Hold After RSCLKx ¹	3.0		3.0		ns
t _{SCLKEW} TSCLKx/RSCLKx Width	8.0		4.5		ns
t _{SCLKE} TSCLKx/RSCLKx Period	20.0		15.0 ²		ns
t _{SUDTE} Start-Up Delay From SPORT Enable To First External TFSx ³	4.0 × t _{SCLKE}		4.0 × t _{SCLKE}		ns
t _{SUDRE} Start-Up Delay From SPORT Enable To First External RFSx ³	4.0 × t _{SCLKE}		4.0 × t _{SCLKE}		ns
<i>Switching Characteristics</i>					
t _{DFSE} TFSx/RFSx Delay After TSCLKx/RSCLKx (Internally Generated TFSx/RFSx) ⁴		10.0		10.0	ns
t _{HOFSE} TFSx/RFSx Hold After TSCLKx/RSCLKx (Internally Generated TFSx/RFSx) ¹	0.0		0.0		ns
t _{DDTE} Transmit Data Delay After TSCLKx ¹		10.0		10.0	ns
t _{HDTE} Transmit Data Hold After TSCLKx ¹	0.0		0.0		ns

¹ Referenced to sample edge.

² For receive mode with external RSCLKx and external RFSx only, the maximum specification is 11.11 ns (90 MHz).

³ Verified in design but untested. After being enabled, the serial port requires external clock pulses—before the first external frame sync edge—to initialize the serial port.

⁴ Referenced to drive edge.

Table 29. Serial Ports—Internal Clock

Parameter	V _{DDEXT} = 1.8 V		V _{DDEXT} = 2.5 V/3.3 V		Unit
	Min	Max	Min	Max	
<i>Timing Requirements</i>					
t _{SFSI} TFSx/RFSx Setup Before TSCLKx/RSCLKx ¹	11.0		9.0		ns
t _{HFSI} TFSx/RFSx Hold After TSCLKx/RSCLKx ¹	−2.0		−2.0		ns
t _{SDRI} Receive Data Setup Before RSCLKx ¹	9.5		9.0		ns
t _{HDRI} Receive Data Hold After RSCLKx ¹	0.0		0.0		ns
<i>Switching Characteristics</i>					
t _{DFSI} TFSx/RFSx Delay After TSCLKx/RSCLKx (Internally Generated TFSx/RFSx) ²		3.0		3.0	ns
t _{HOFSI} TFSx/RFSx Hold After TSCLKx/RSCLKx (Internally Generated TFSx/RFSx) ¹	−1.0		−1.0		ns
t _{DDTI} Transmit Data Delay After TSCLKx ¹		3.0		3.0	ns
t _{HDTI} Transmit Data Hold After TSCLKx ¹	−2.5		−2.0		ns
t _{SCLKIW} TSCLKx/RSCLKx Width	6.0		4.5		ns

¹ Referenced to sample edge.

² Referenced to drive edge.

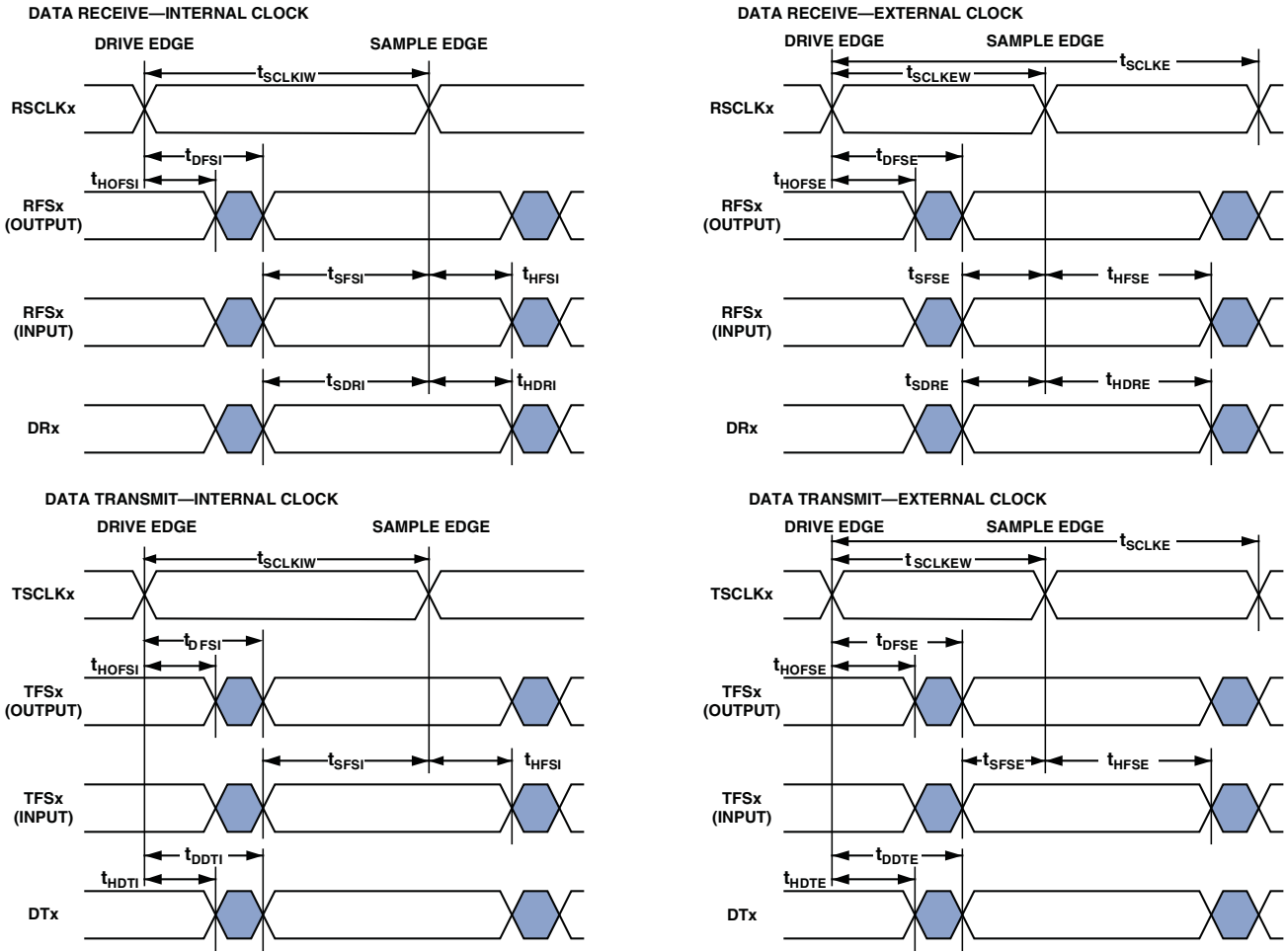

Figure 23. Serial Ports

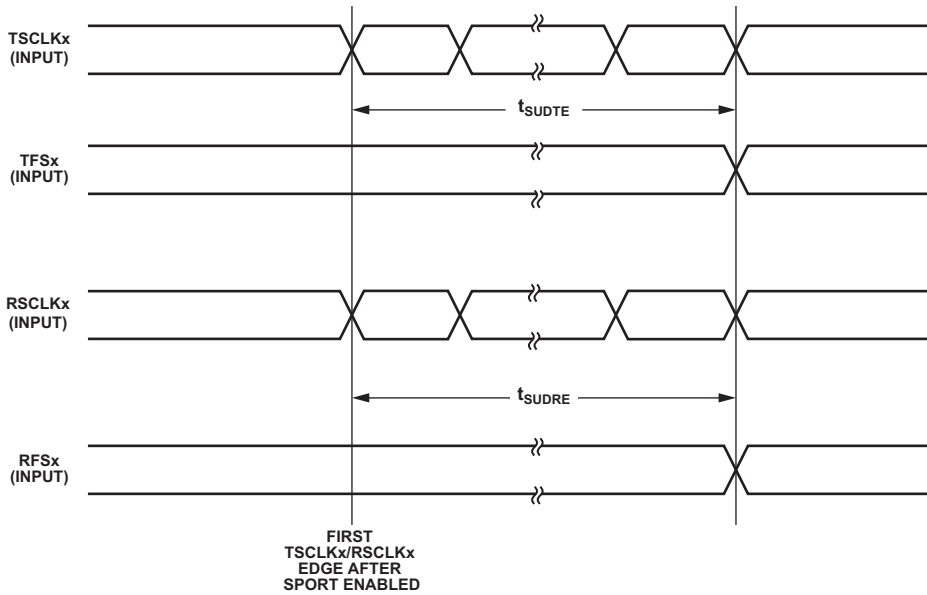

Figure 24. Serial Port Start Up with External Clock and Frame Sync

ADSP-BF531/ADSP-BF532/ADSP-BF533

Table 30. Serial Ports—Enable and Three-State

Parameter	$V_{DDEXT} = 1.8\text{ V}$		$V_{DDEXT} = 2.5\text{ V}/3.3\text{ V}$		Unit
	Min	Max	Min	Max	
<i>Switching Characteristics</i>					
t_{DTENE} Data Enable Delay from External TSCLKx ¹	0		0		ns
t_{DDTTE} Data Disable Delay from External TSCLKx ^{1, 2, 3}		10.0		10.0	ns
t_{DTENI} Data Enable Delay from Internal TSCLKx ¹	-2.0		-2.0		ns
t_{DDTTI} Data Disable Delay from Internal TSCLKx ^{1, 2, 3}		3.0		3.0	ns

¹ Referenced to drive edge.

² Applicable to multichannel mode only.

³ TSCLKx is tied to RSCLKx.

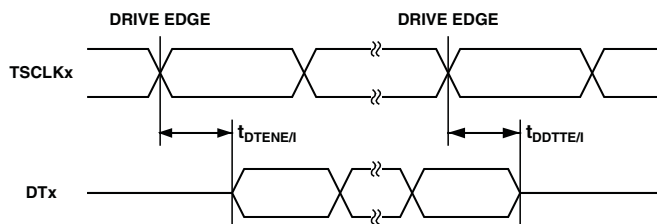

Figure 25. Enable and Three-State

ADSP-BF531/ADSP-BF532/ADSP-BF533

Table 31. External Late Frame Sync

Parameter	$V_{DDEXT} = 1.8\text{ V}$ LQFP/PBGA Packages		$V_{DDEXT} = 1.8\text{ V}$ CSP_BGA Package		$V_{DDEXT} = 2.5\text{ V}/3.3\text{ V}$ All Packages		Unit
	Min	Max	Min	Max	Min	Max	
<i>Switching Characteristics</i>							
$t_{DDTLFSE}$ Data Delay from Late External TFSx or External RFSx in multichannel mode with MCMEN = 0 ^{1,2}		10.5		10.0		10.0	ns
$t_{DTENLFS}$ Data Enable from Late FS or in multichannel mode with MCMEN = 0 ^{1,2}	0		0		0		ns

¹ In multichannel mode, TFSx enable and TFSx valid follow $t_{DTENLFS}$ and $t_{DDTLFSE}$.

² If external RFSx/TFSx setup to $RSCLKx/TSCLKx > t_{SCLKE}/2$, then $t_{DDTTE/I}$ and $t_{DTENE/I}$ apply; otherwise $t_{DDTLFSE}$ and $t_{DTENLFS}$ apply.

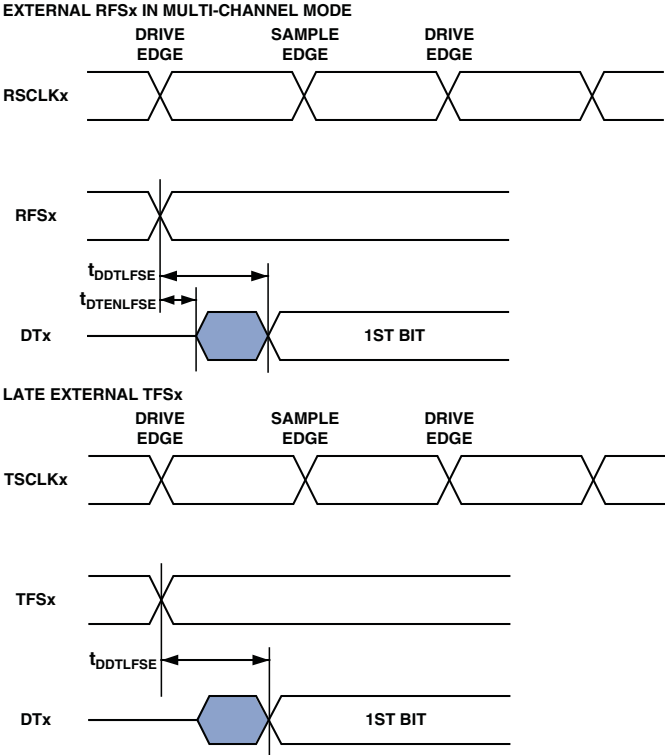

Figure 26. External Late Frame Sync

ADSP-BF531/ADSP-BF532/ADSP-BF533

Serial Peripheral Interface (SPI) Port—Master Timing

Table 32. Serial Peripheral Interface (SPI) Port—Master Timing

Parameter	$V_{DDEXT} = 1.8\text{ V}$ LQFP/PBGA Packages		$V_{DDEXT} = 1.8\text{ V}$ CSP_BGA Package		$V_{DDEXT} = 2.5\text{ V}/3.3\text{ V}$ All Packages		Unit
	Min	Max	Min	Max	Min	Max	
<i>Timing Requirements</i>							
t_{SSPIDM} Data Input Valid to SCK Edge (Data Input Setup)	10.5		9		7.5		ns
t_{HSPIDM} SCK Sampling Edge to Data Input Invalid	-1.5		-1.5		-1.5		ns
<i>Switching Characteristics</i>							
t_{SDSCIM} $\overline{\text{SPISSELx}}$ Low to First SCK Edge	$2 \times t_{SCLK} - 1.5$		$2 \times t_{SCLK} - 1.5$		$2 \times t_{SCLK} - 1.5$		ns
t_{SPICHM} Serial Clock High Period	$2 \times t_{SCLK} - 1.5$		$2 \times t_{SCLK} - 1.5$		$2 \times t_{SCLK} - 1.5$		ns
t_{SPICLM} Serial Clock Low Period	$2 \times t_{SCLK} - 1.5$		$2 \times t_{SCLK} - 1.5$		$2 \times t_{SCLK} - 1.5$		ns
t_{SPICLK} Serial Clock Period	$4 \times t_{SCLK} - 1.5$		$4 \times t_{SCLK} - 1.5$		$4 \times t_{SCLK} - 1.5$		ns
t_{HDSTM} Last SCK Edge to $\overline{\text{SPISSELx}}$ High	$2 \times t_{SCLK} - 1.5$		$2 \times t_{SCLK} - 1.5$		$2 \times t_{SCLK} - 1.5$		ns
t_{SPITDM} Sequential Transfer Delay	$2 \times t_{SCLK} - 1.5$		$2 \times t_{SCLK} - 1.5$		$2 \times t_{SCLK} - 1.5$		ns
$t_{DDSPIDM}$ SCK Edge to Data Out Valid (Data Out Delay)		6		6		6	ns
$t_{HDSPIDM}$ SCK Edge to Data Out Invalid (Data Out Hold)	-1.0		-1.0		-1.0		ns

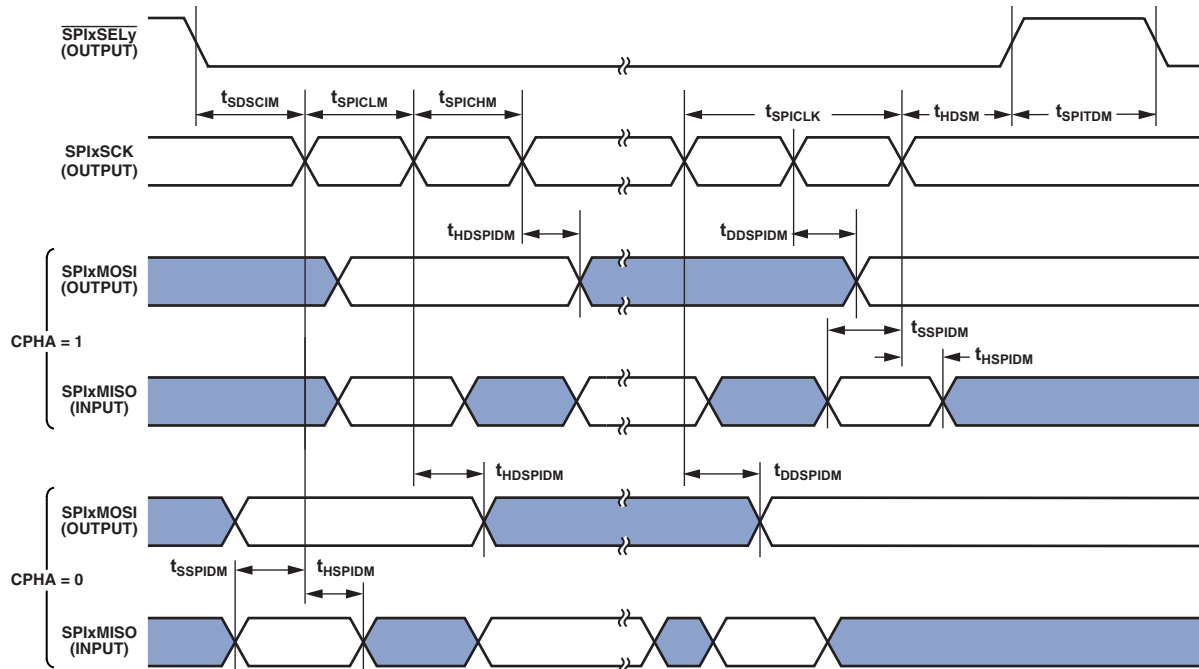

Figure 27. Serial Peripheral Interface (SPI) Port—Master Timing

ADSP-BF531/ADSP-BF532/ADSP-BF533

Serial Peripheral Interface (SPI) Port—Slave Timing

Table 33. Serial Peripheral Interface (SPI) Port—Slave Timing

Parameter	$V_{DDEXT} = 1.8\text{ V}$ LQFP/PBGA Packages		$V_{DDEXT} = 1.8\text{ V}$ CSP_BGA Package		$V_{DDEXT} = 2.5\text{ V}/3.3\text{ V}$ All Packages		Unit
	Min	Max	Min	Max	Min	Max	
<i>Timing Requirements</i>							
$t_{SPICHHS}$ Serial Clock High Period	$2 \times t_{SCLK} - 1.5$		$2 \times t_{SCLK} - 1.5$		$2 \times t_{SCLK} - 1.5$		ns
t_{SPICLS} Serial Clock Low Period	$2 \times t_{SCLK} - 1.5$		$2 \times t_{SCLK} - 1.5$		$2 \times t_{SCLK} - 1.5$		ns
t_{SPICLK} Serial Clock Period	$4 \times t_{SCLK}$		$4 \times t_{SCLK}$		$4 \times t_{SCLK}$		ns
t_{HDS} Last SCK Edge to \overline{SPiSS} Not Asserted	$2 \times t_{SCLK} - 1.5$		$2 \times t_{SCLK} - 1.5$		$2 \times t_{SCLK} - 1.5$		ns
t_{SPITDS} Sequential Transfer Delay	$2 \times t_{SCLK} - 1.5$		$2 \times t_{SCLK} - 1.5$		$2 \times t_{SCLK} - 1.5$		ns
t_{SDSCI} \overline{SPiSS} Assertion to First SCK Edge	$2 \times t_{SCLK} - 1.5$		$2 \times t_{SCLK} - 1.5$		$2 \times t_{SCLK} - 1.5$		ns
t_{SSPID} Data Input Valid to SCK Edge (Data Input Setup)	1.6		1.6		1.6		ns
t_{HSPID} SCK Sampling Edge to Data Input Invalid	1.6		1.6		1.6		ns
<i>Switching Characteristics</i>							
t_{DSOE} \overline{SPiSS} Assertion to Data Out Active	0	10	0	9	0	8	ns
t_{DSDHI} \overline{SPiSS} Deassertion to Data High Impedance	0	10	0	9	0	8	ns
t_{DDSPID} SCK Edge to Data Out Valid (Data Out Delay)		10		10		10	ns
t_{HDSPID} SCK Edge to Data Out Invalid (Data Out Hold)	0		0		0		ns

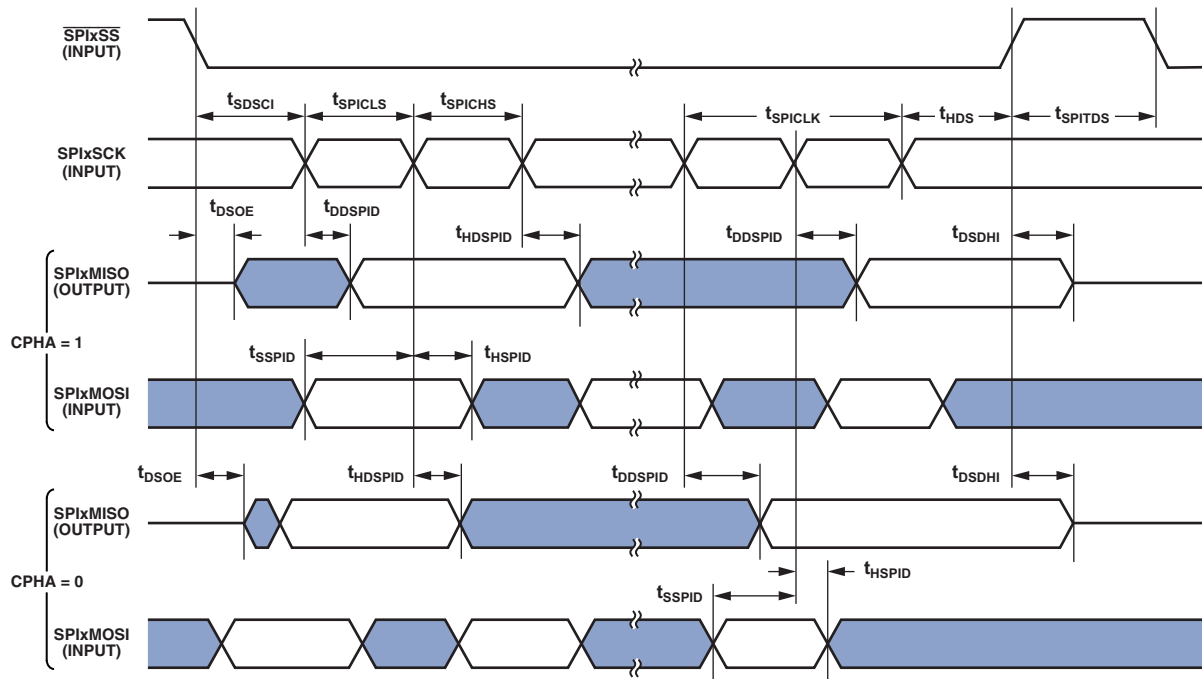

Figure 28. Serial Peripheral Interface (SPI) Port—Slave Timing

ADSP-BF531/ADSP-BF532/ADSP-BF533

General-Purpose I/O Port F Pin Cycle Timing

Table 34. General-Purpose I/O Port F Pin Cycle Timing

Parameter	$V_{DDEXT} = 1.8\text{ V}$		$V_{DDEXT} = 2.5\text{ V}/3.3\text{ V}$		Unit
	Min	Max	Min	Max	
<i>Timing Requirement</i>					
t_{WFI} GPIO Input Pulse Width	$t_{SCLK} + 1$		$t_{SCLK} + 1$		ns
<i>Switching Characteristic</i>					
t_{GPOD} GPIO Output Delay from CLKOUT Low	6		6		ns

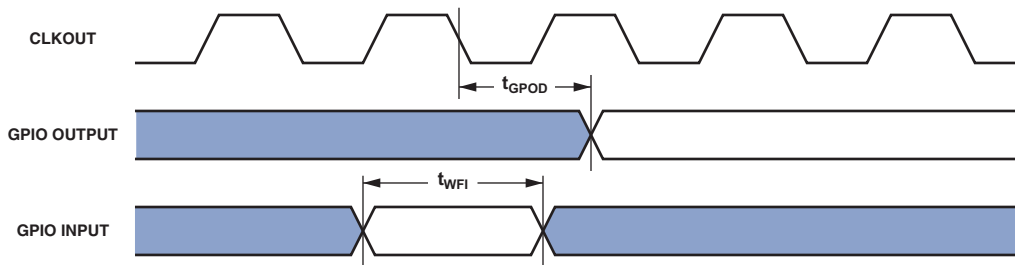

Figure 29. GPIO Cycle Timing

Universal Asynchronous Receiver-Transmitter (UART) Ports—Receive and Transmit Timing

For information on the UART port receive and transmit operations, see the *ADSP-BF533 Blackfin Processor Hardware Reference*.

Timer Clock Timing

Table 35 and Figure 30 describe timer clock timing.

Table 35. Timer Clock Timing

Parameter	Min	Max	Unit
<i>Switching Characteristic</i>			
t_{TODP} Timer Output Update Delay After PPI_CLK High		12	ns

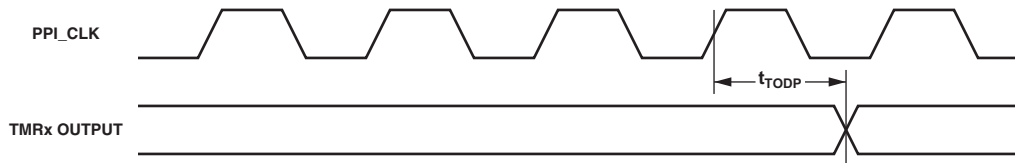

Figure 30. Timer Clock Timing

Timer Cycle Timing

Table 36 and Figure 31 describe timer expired operations. The input signal is asynchronous in width capture mode and external clock mode and has an absolute maximum input frequency of $f_{SCLK}/2$ MHz.

Table 36. Timer Cycle Timing

Parameter	$V_{DDEXT} = 1.8\text{ V}$		$V_{DDEXT} = 2.5\text{ V}/3.3\text{ V}$		Unit
	Min	Max	Min	Max	
<i>Timing Characteristics</i>					
t_{WL} Timer Pulse Width Low ¹	$1 \times t_{SCLK}$		$1 \times t_{SCLK}$		ns
t_{WH} Timer Pulse Width High ¹	$1 \times t_{SCLK}$		$1 \times t_{SCLK}$		ns
t_{TIS} Timer Input Setup Time Before CLKOUT Low ²	8.0		6.5		ns
t_{TIH} Timer Input Hold Time After CLKOUT Low ²	1.5		1.5		ns
<i>Switching Characteristics</i>					
t_{HTO} Timer Pulse Width Output	$1 \times t_{SCLK}$	$(2^{32}-1) \times t_{SCLK}$	$1 \times t_{SCLK}$	$(2^{32}-1) \times t_{SCLK}$	ns
t_{TOD} Timer Output Update Delay After CLKOUT High		7.5		6.5	ns

¹ The minimum pulse widths apply for TMRx input pins in width capture and external clock modes. They also apply to the PF1 or PPI_CLK input pins in PWM output mode.

² Either a valid setup and hold time or a valid pulse width is sufficient. There is no need to resynchronize programmable flag inputs.

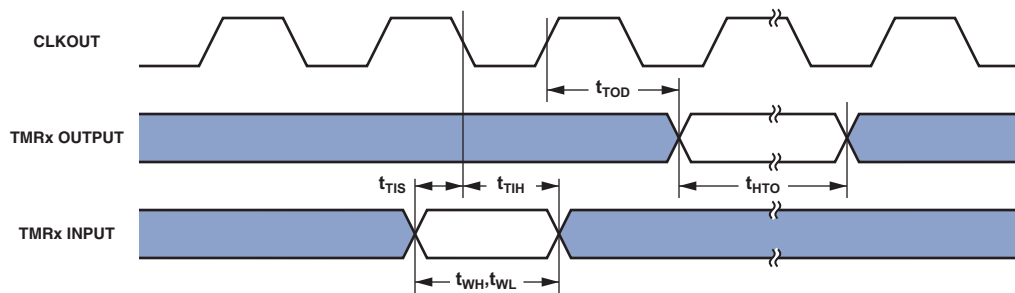

Figure 31. Timer PWM_OUT Cycle Timing

ADSP-BF531/ADSP-BF532/ADSP-BF533

JTAG Test and Emulation Port Timing

Table 37. JTAG Port Timing

Parameter	$V_{DDEXT} = 1.8\text{ V}$		$V_{DDEXT} = 2.5\text{ V}/3.3\text{ V}$		Unit
	Min	Max	Min	Max	
<i>Timing Requirements</i>					
t_{TCK} TCK Period	20		20		ns
t_{STAP} TDI, TMS Setup Before TCK High	4		4		ns
t_{HTAP} TDI, TMS Hold After TCK High	4		4		ns
t_{SSYS} System Inputs Setup Before TCK High ¹	4		4		ns
t_{HSYS} System Inputs Hold After TCK High ¹	5		5		ns
t_{TRSTW} \overline{TRST} Pulse Width ² (Measured in TCK Cycles)	4		4		TCK
<i>Switching Characteristics</i>					
t_{DTDO} TDO Delay from TCK Low		10		10	ns
t_{DSYS} System Outputs Delay After TCK Low ³	0	12	0	12	ns

¹ System Inputs = DATA15-0, ARDY, TMR2-0, PF15-0, PPI_CLK, RSCLK0-1, RFS0-1, DR0PRI, DR0SEC, TSCLK0-1, TFS0-1, DR1PRI, DR1SEC, MOSI, MISO, SCK, RX, \overline{RESET} , NMI, BMODE1-0, \overline{BR} , PPI3-0.

² 50 MHz maximum.

³ System Outputs = DATA15-0, ADDR19-1, $\overline{ABE1-0}$, AOE, ARE, AWE, AMS3-0, SRAS, SCAS, SWE, SCKE, CLKOUT, SA10, \overline{SMS} , TMR2-0, PF15-0, RSCLK0-1, RFS0-1, TSCLK0-1, TFS0-1, DT0PRI, DT0SEC, DT1PRI, DT1SEC, MOSI, MISO, SCK, TX, \overline{BG} , \overline{BGH} , PPI3-0.

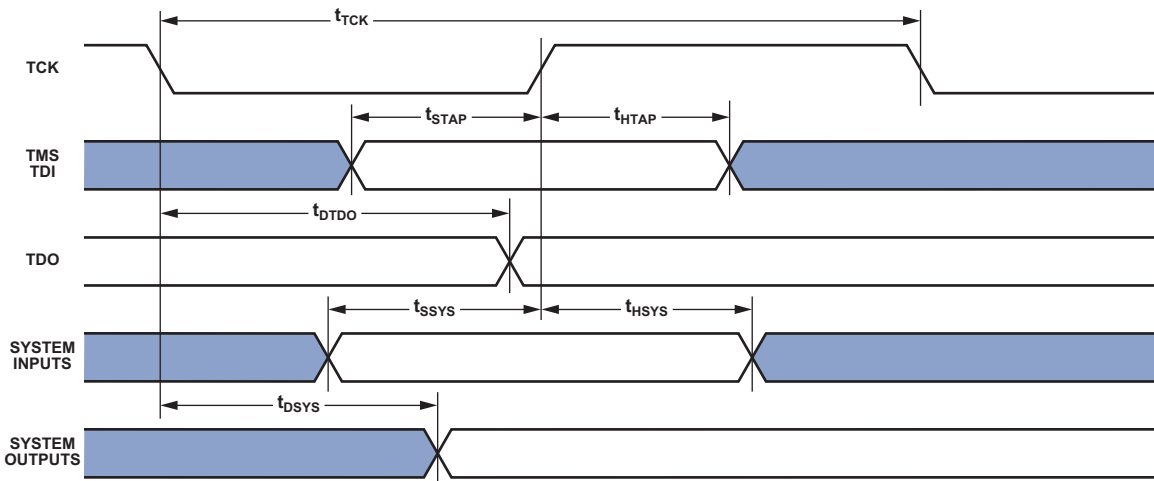

Figure 32. JTAG Port Timing

OUTPUT DRIVE CURRENTS

Figure 33 through Figure 44 show typical current-voltage characteristics for the output drivers of the processors. The curves represent the current drive capability of the output drivers as a function of output voltage.

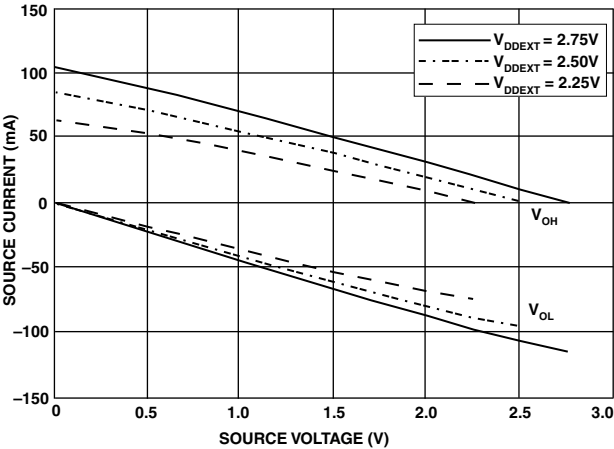

Figure 33. Drive Current A ($V_{DDEXT} = 2.5\text{ V}$)

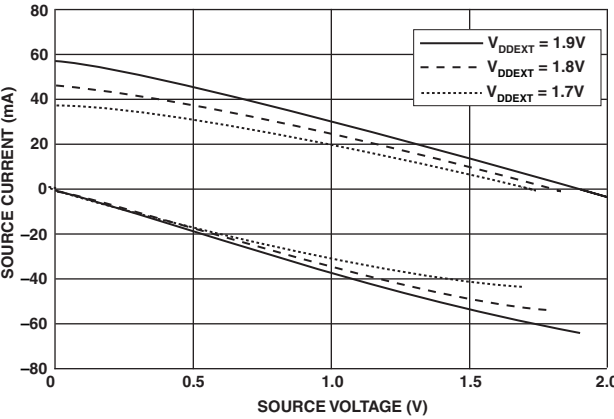

Figure 34. Drive Current A ($V_{DDEXT} = 1.8\text{ V}$)

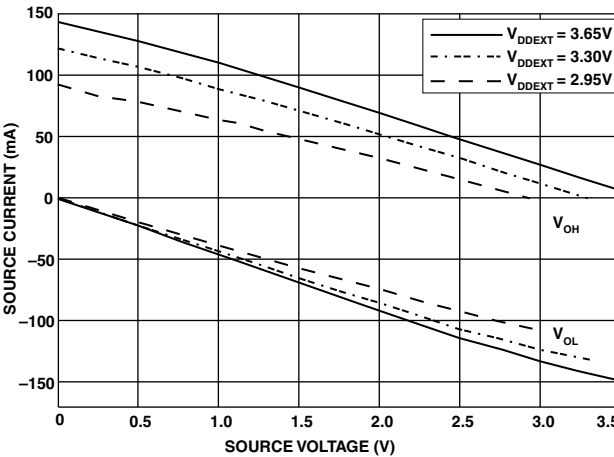

Figure 35. Drive Current A ($V_{DDEXT} = 3.3\text{ V}$)

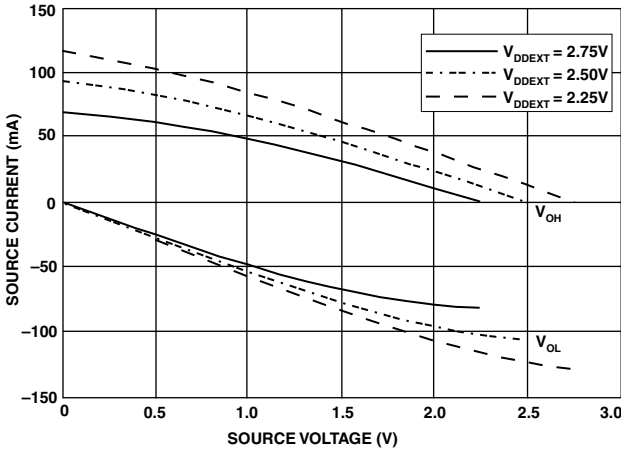

Figure 36. Drive Current B ($V_{DDEXT} = 2.5\text{ V}$)

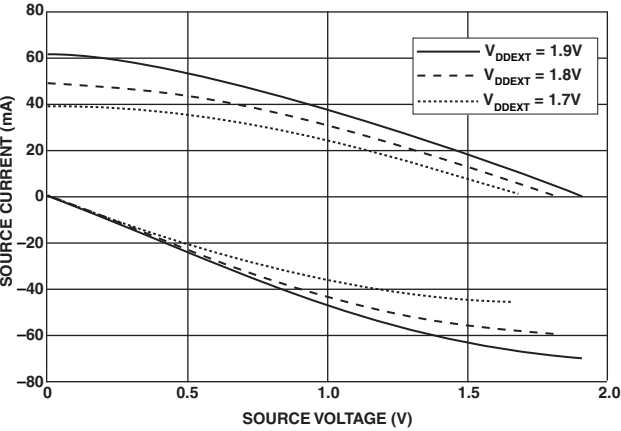

Figure 37. Drive Current B ($V_{DDEXT} = 1.8\text{ V}$)

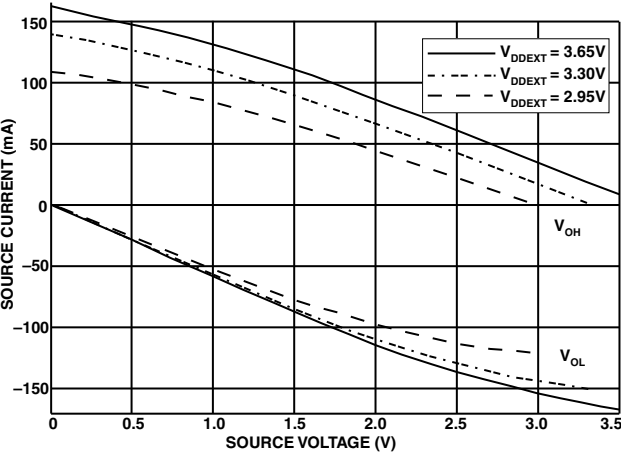

Figure 38. Drive Current B ($V_{DDEXT} = 3.3\text{ V}$)

ADSP-BF531/ADSP-BF532/ADSP-BF533

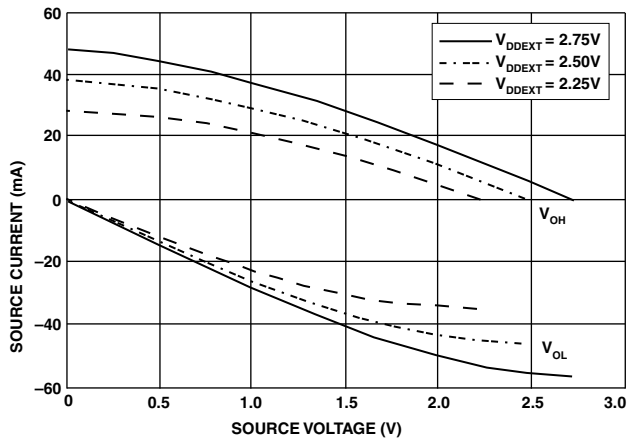

Figure 39. Drive Current C ($V_{DDEXT} = 2.5\text{ V}$)

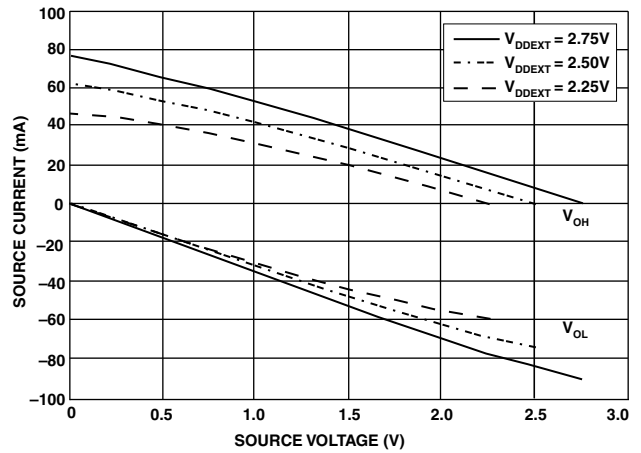

Figure 42. Drive Current D ($V_{DDEXT} = 2.5\text{ V}$)

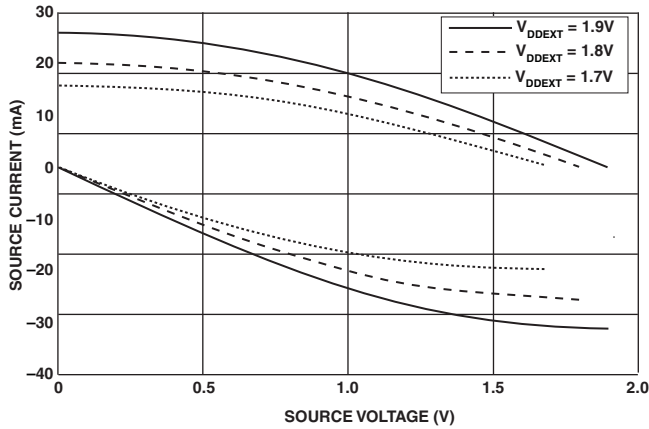

Figure 40. Drive Current C ($V_{DDEXT} = 1.8\text{ V}$)

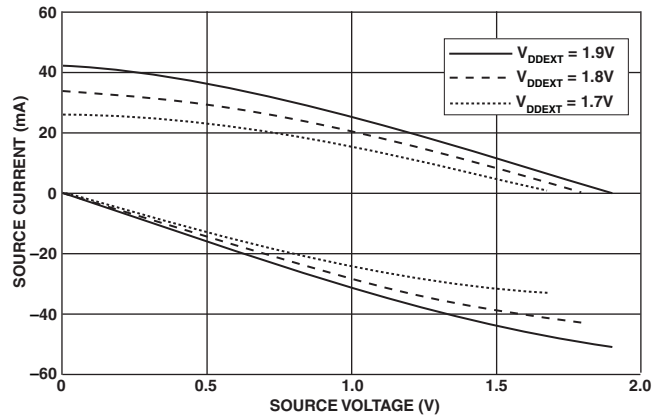

Figure 43. Drive Current D ($V_{DDEXT} = 1.8\text{ V}$)

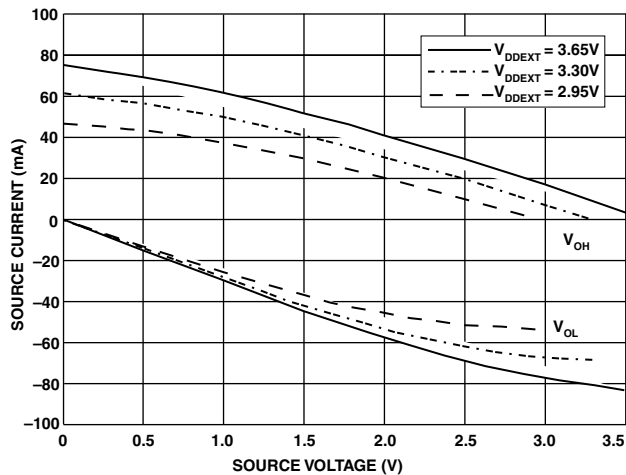

Figure 41. Drive Current C ($V_{DDEXT} = 3.3\text{ V}$)

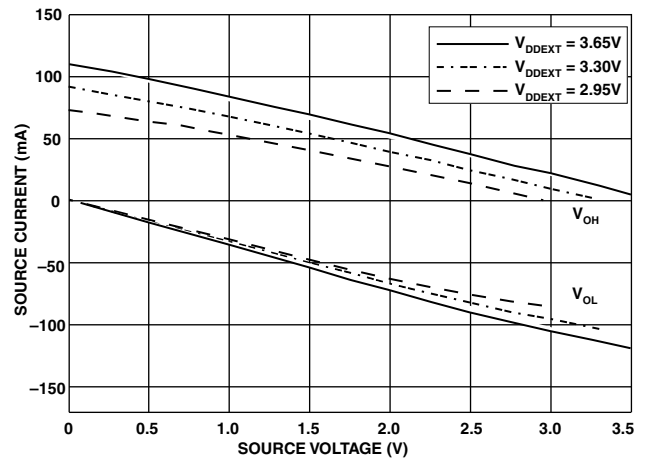

Figure 44. Drive Current D ($V_{DDEXT} = 3.3\text{ V}$)

TEST CONDITIONS

All timing parameters appearing in this data sheet were measured under the conditions described in this section. Figure 45 shows the measurement point for ac measurements (except output enable/disable). The measurement point V_{MEAS} is 0.95 V for V_{DDEXT} (nominal) = 1.8 V or 1.5 V for V_{DDEXT} (nominal) = 2.5 V/3.3 V.

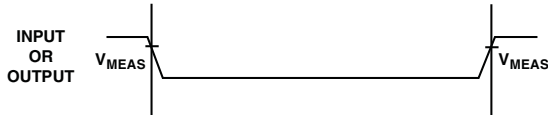

Figure 45. Voltage Reference Levels for AC Measurements (Except Output Enable/Disable)

Output Enable Time Measurement

Output pins are considered to be enabled when they have made a transition from a high impedance state to the point when they start driving.

The output enable time t_{ENA} is the interval from the point when a reference signal reaches a high or low voltage level to the point when the output starts driving as shown on the right side of Figure 46.

The time $t_{ENA_MEASURED}$ is the interval, from when the reference signal switches, to when the output voltage reaches V_{TRIP} (high) or V_{TRIP} (low).

For V_{DDEXT} (nominal) = 1.8 V— V_{TRIP} (high) is 1.3 V and V_{TRIP} (low) is 0.7 V.

For V_{DDEXT} (nominal) = 2.5 V/3.3 V— V_{TRIP} (high) is 2.0 V and V_{TRIP} (low) is 1.0 V.

Time t_{TRIP} is the interval from when the output starts driving to when the output reaches the V_{TRIP} (high) or V_{TRIP} (low) trip voltage.

Time t_{ENA} is calculated as shown in the equation:

$$t_{ENA} = t_{ENA_MEASURED} - t_{TRIP}$$

If multiple pins (such as the data bus) are enabled, the measurement value is that of the first pin to start driving.

Output Disable Time Measurement

Output pins are considered to be disabled when they stop driving, go into a high impedance state, and start to decay from their output high or low voltage. The output disable time t_{DIS} is the difference between $t_{DIS_MEASURED}$ and t_{DECAY} as shown on the left side of Figure 45.

$$t_{DIS} = t_{DIS_MEASURED} - t_{DECAY}$$

The time for the voltage on the bus to decay by ΔV is dependent on the capacitive load C_L and the load current I_L . This decay time can be approximated by the equation:

$$t_{DECAY} = (C_L \Delta V) / I_L$$

The time t_{DECAY} is calculated with test loads C_L and I_L and with ΔV equal to 0.1 V for V_{DDEXT} (nominal) = 1.8 V or 0.5 V for V_{DDEXT} (nominal) = 2.5 V/3.3 V.

The time $t_{DIS_MEASURED}$ is the interval from when the reference signal switches, to when the output voltage decays ΔV from the measured output high or output low voltage.

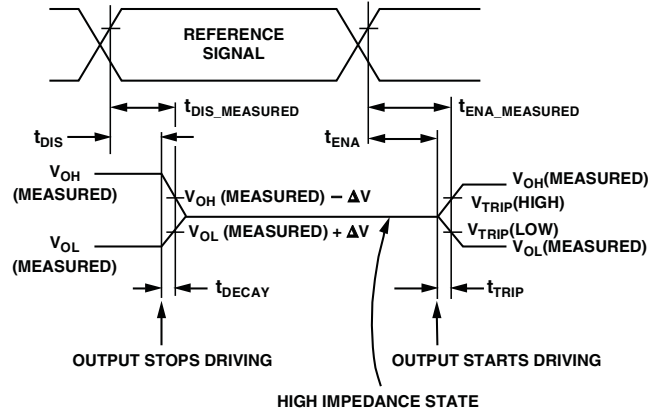

Figure 46. Output Enable/Disable

Example System Hold Time Calculation

To determine the data output hold time in a particular system, first calculate t_{DECAY} using the equation given above. Choose ΔV to be the difference between the processor's output voltage and the input threshold for the device requiring the hold time. C_L is the total bus capacitance (per data line), and I_L is the total leakage or three-state current (per data line). The hold time is t_{DECAY} plus the various output disable times as specified in the [Timing Specifications on Page 27](#) (for example t_{DSDAT} for an SDRAM write cycle as shown in [SDRAM Interface Timing on Page 30](#)).

ADSP-BF531/ADSP-BF532/ADSP-BF533

Capacitive Loading

Output delays and holds are based on standard capacitive loads: 30 pF on all pins (see Figure 47). V_{LOAD} is 0.95 V for V_{DDEXT} (nominal) = 1.8 V or 1.5 V for V_{DDEXT} (nominal) = 2.5 V/3.3 V. Figure 48 through Figure 59 on Page 48 show how output rise time varies with capacitance. The delay and hold specifications given should be derated by a factor derived from these figures. The graphs in these figures may not be linear outside the ranges shown.

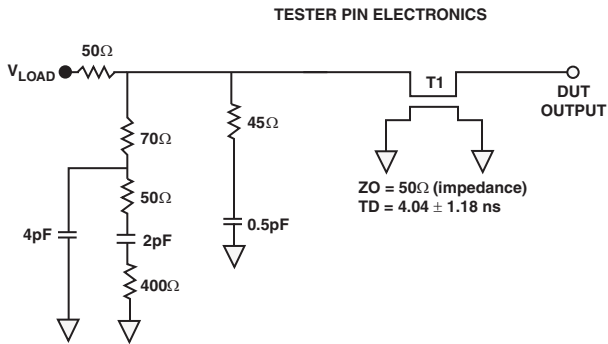

NOTES:
THE WORST CASE TRANSMISSION LINE DELAY IS SHOWN AND CAN BE USED FOR THE OUTPUT TIMING ANALYSIS TO REFLECT THE TRANSMISSION LINE EFFECT AND MUST BE CONSIDERED. THE TRANSMISSION LINE (TD) IS FOR LOAD ONLY AND DOES NOT AFFECT THE DATA SHEET TIMING SPECIFICATIONS.

ANALOG DEVICES RECOMMENDS USING THE IBIS MODEL TIMING FOR A GIVEN SYSTEM REQUIREMENT. IF NECESSARY, A SYSTEM MAY INCORPORATE EXTERNAL DRIVERS TO COMPENSATE FOR ANY TIMING DIFFERENCES.

Figure 47. Equivalent Device Loading for AC Measurements (Includes All Fixtures)

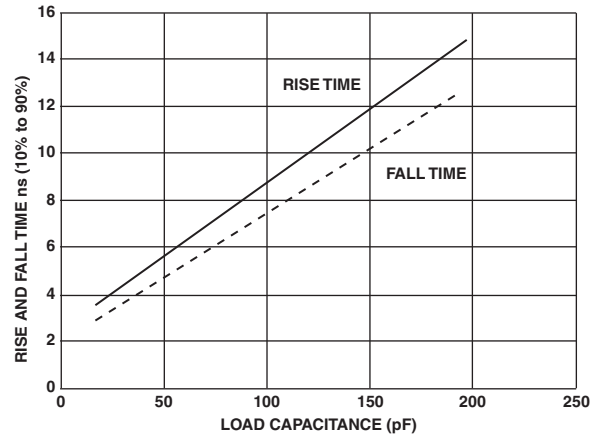

Figure 48. Typical Rise and Fall Times (10% to 90%) vs. Load Capacitance for Driver A at $V_{DDEXT} = 1.75$ V

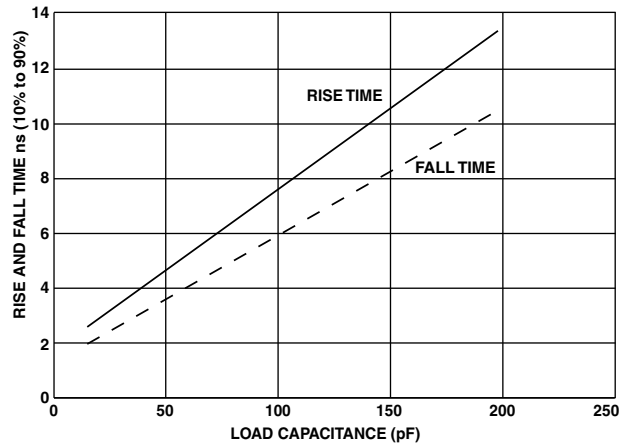

Figure 49. Typical Rise and Fall Times (10% to 90%) vs. Load Capacitance for Driver A at $V_{DDEXT} = 2.25$ V

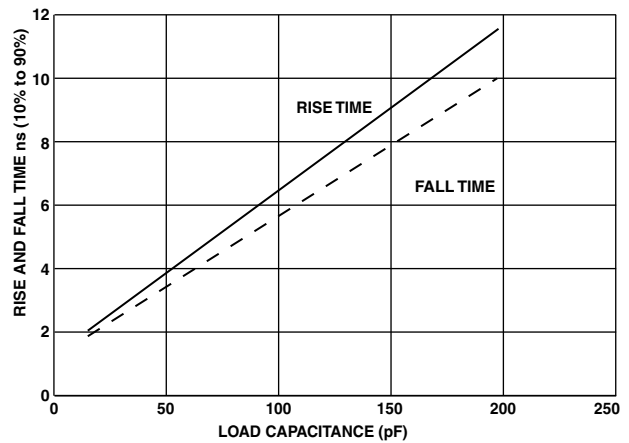

Figure 50. Typical Rise and Fall Times (10% to 90%) vs. Load Capacitance for Driver A at $V_{DDEXT} = 3.65$ V

ADSP-BF531/ADSP-BF532/ADSP-BF533

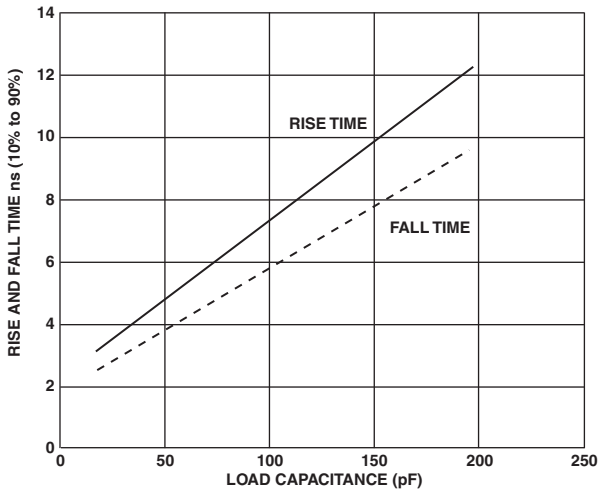

Figure 51. Typical Rise and Fall Times (10% to 90%) vs. Load Capacitance for Driver B at $V_{DDEXT} = 1.75\text{ V}$

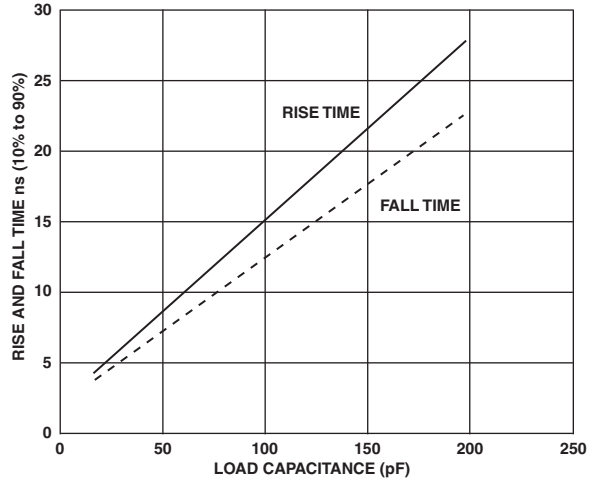

Figure 54. Typical Rise and Fall Times (10% to 90%) vs. Load Capacitance for Driver C at $V_{DDEXT} = 1.75\text{ V}$

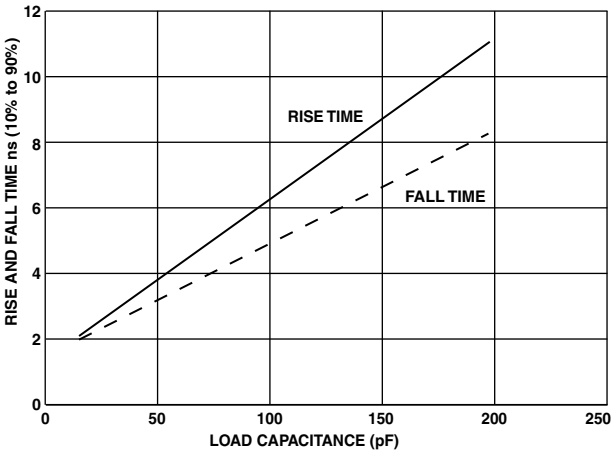

Figure 52. Typical Rise and Fall Times (10% to 90%) vs. Load Capacitance for Driver B at $V_{DDEXT} = 2.25\text{ V}$

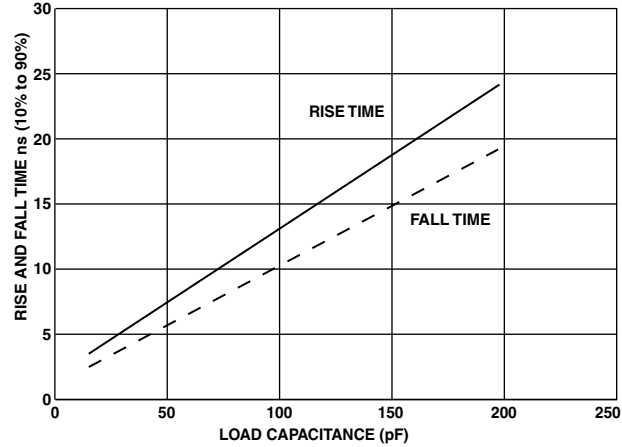

Figure 55. Typical Rise and Fall Times (10% to 90%) vs. Load Capacitance for Driver C at $V_{DDEXT} = 2.25\text{ V}$

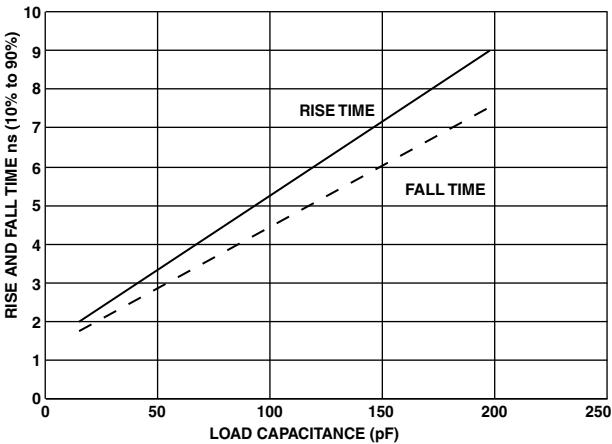

Figure 53. Typical Rise and Fall Times (10% to 90%) vs. Load Capacitance for Driver B at $V_{DDEXT} = 3.65\text{ V}$

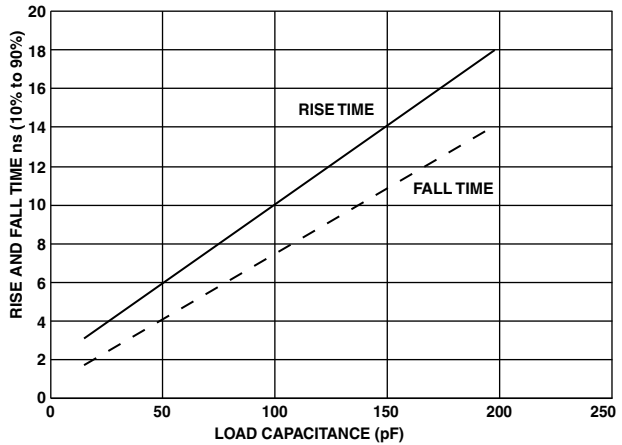

Figure 56. Typical Rise and Fall Times (10% to 90%) vs. Load Capacitance for Driver C at $V_{DDEXT} = 3.65\text{ V}$

ADSP-BF531/ADSP-BF532/ADSP-BF533

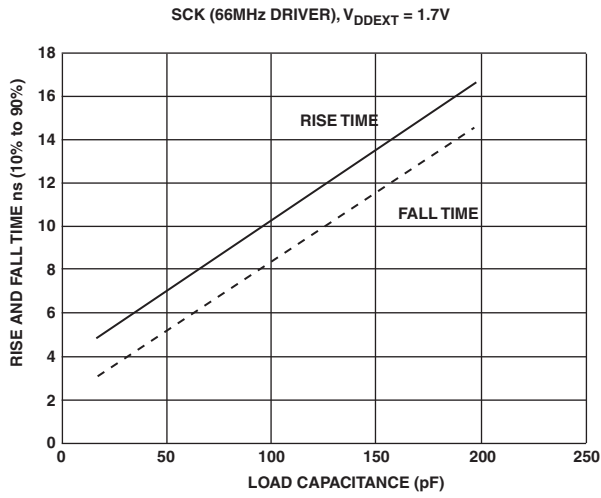

Figure 57. Typical Rise and Fall Times (10% to 90%) vs. Load Capacitance for Driver D at $V_{DDEXT} = 1.75V$

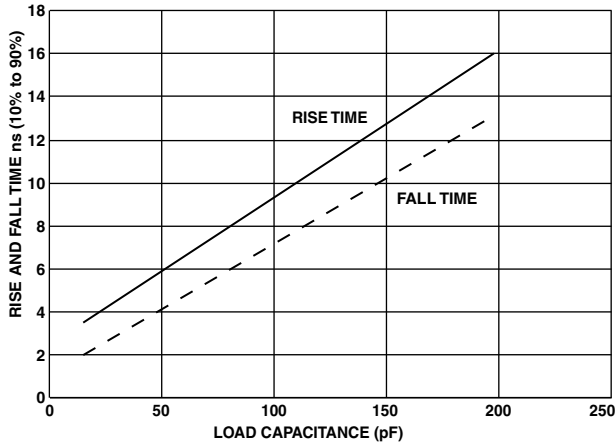

Figure 58. Typical Rise and Fall Times (10% to 90%) vs. Load Capacitance for Driver D at $V_{DDEXT} = 2.25V$

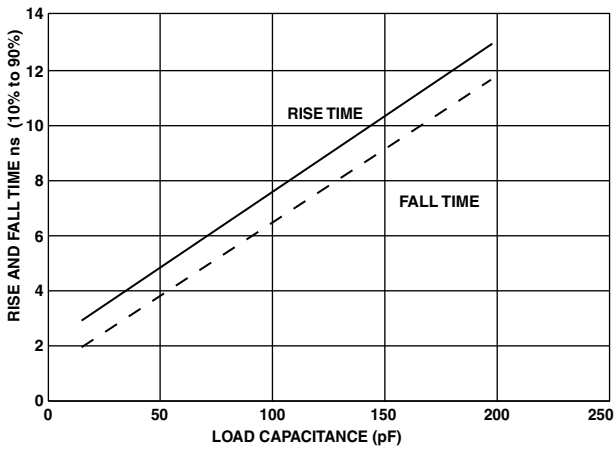

Figure 59. Typical Rise and Fall Times (10% to 90%) vs. Load Capacitance for Driver D at $V_{DDEXT} = 3.65V$

THERMAL CHARACTERISTICS

To determine the junction temperature on the application printed circuit board, use:

$$T_J = T_{CASE} + (\Psi_{JT} \times P_D)$$

where:

T_J = Junction temperature (°C).

T_{CASE} = Case temperature (°C) measured by customer at top center of package.

Ψ_{JT} = From [Table 38](#) through [Table 40](#).

P_D = Power dissipation (see the power dissipation discussion and the tables on [23](#) for the method to calculate P_D).

Values of θ_{JA} are provided for package comparison and printed circuit board design considerations. θ_{JA} can be used for a first order approximation of T_J by the equation:

$$T_J = T_A + (\theta_{JA} \times P_D)$$

where:

T_A = ambient temperature (°C).

In [Table 38](#) through [Table 40](#), airflow measurements comply with JEDEC standards JESD51-2 and JESD51-6, and the junction-to-board measurement complies with JESD51-8. The junction-to-case measurement complies with MIL-STD-883 (Method 1012.1). All measurements use a 2S2P JEDEC test board.

Thermal resistance θ_{JA} in [Table 38](#) through [Table 40](#) is the figure of merit relating to performance of the package and board in a convective environment. θ_{JMA} represents the thermal resistance under two conditions of airflow. Ψ_{JT} represents the correlation between T_J and T_{CASE} .

Table 38. Thermal Characteristics for BC-160 Package

Parameter	Condition	Typical	Unit
θ_{JA}	0 Linear m/s Airflow	27.1	°C/W
θ_{JMA}	1 Linear m/s Airflow	23.85	°C/W
θ_{JMA}	2 Linear m/s Airflow	22.7	°C/W
θ_{JC}	Not Applicable	7.26	°C/W
Ψ_{JT}	0 Linear m/s Airflow	0.14	°C/W
Ψ_{JT}	1 Linear m/s Airflow	0.26	°C/W
Ψ_{JT}	2 Linear m/s Airflow	0.35	°C/W

Table 39. Thermal Characteristics for ST-176-1 Package

Parameter	Condition	Typical	Unit
θ_{JA}	0 Linear m/s Airflow	34.9	°C/W
θ_{JMA}	1 Linear m/s Airflow	33.0	°C/W
θ_{JMA}	2 Linear m/s Airflow	32.0	°C/W
Ψ_{JT}	0 Linear m/s Airflow	0.50	°C/W
Ψ_{JT}	1 Linear m/s Airflow	0.75	°C/W
Ψ_{JT}	2 Linear m/s Airflow	1.00	°C/W

Table 40. Thermal Characteristics for B-169 Package

Parameter	Condition	Typical	Unit
θ_{JA}	0 Linear m/s Airflow	22.8	°C/W
θ_{JMA}	1 Linear m/s Airflow	20.3	°C/W
θ_{JMA}	2 Linear m/s Airflow	19.3	°C/W
θ_{JC}	Not Applicable	10.39	°C/W
Ψ_{JT}	0 Linear m/s Airflow	0.59	°C/W
Ψ_{JT}	1 Linear m/s Airflow	0.88	°C/W
Ψ_{JT}	2 Linear m/s Airflow	1.37	°C/W

ADSP-BF531/ADSP-BF532/ADSP-BF533

160-BALL CSP_BGA BALL ASSIGNMENT

Table 41 lists the CSP_BGA ball assignment by signal. Table 42 on Page 51 lists the CSP_BGA ball assignment by ball number.

Table 41. 160-Ball CSP_BGA Ball Assignment (Alphabetical by Signal)

Signal	Ball No.	Signal	Ball No.	Signal	Ball No.	Signal	Ball No.
$\overline{ABE0}$	H13	DATA4	N8	GND	L6	SCK	D1
$\overline{ABE1}$	H12	DATA5	P8	GND	L8	SCKE	B13
ADDR1	J14	DATA6	M7	GND	L10	\overline{SMS}	C13
ADDR2	K14	DATA7	N7	GND	M4	\overline{SRAS}	D13
ADDR3	L14	DATA8	P7	GND	M10	\overline{SWE}	D12
ADDR4	J13	DATA9	M6	GND	P14	TCK	P2
ADDR5	K13	DATA10	N6	MISO	E2	TDI	M3
ADDR6	L13	DATA11	P6	MOSI	D3	TDO	N3
ADDR7	K12	DATA12	M5	NMI	B10	TFS0	H3
ADDR8	L12	DATA13	N5	PF0	D2	TFS1	E1
ADDR9	M12	DATA14	P5	PF1	C1	TMRO	L2
ADDR10	M13	DATA15	P4	PF2	C2	TMR1	M1
ADDR11	M14	DR0PRI	K1	PF3	C3	TMR2	K2
ADDR12	N14	DR0SEC	J2	PF4	B1	TMS	N2
ADDR13	N13	DR1PRI	G3	PF5	B2	\overline{TRST}	N1
ADDR14	N12	DR1SEC	F3	PF6	B3	TSCLK0	J1
ADDR15	M11	DT0PRI	H1	PF7	B4	TSCLK1	F1
ADDR16	N11	DT0SEC	H2	PF8	A2	TX	K3
ADDR17	P13	DT1PRI	F2	PF9	A3	V _{DDEXT}	A1
ADDR18	P12	DT1SEC	E3	PF10	A4	V _{DDEXT}	C7
ADDR19	P11	\overline{EMU}	M2	PF11	A5	V _{DDEXT}	C12
$\overline{AMS0}$	E14	GND	A10	PF12	B5	V _{DDEXT}	D5
$\overline{AMS1}$	F14	GND	A14	PF13	B6	V _{DDEXT}	D9
$\overline{AMS2}$	F13	GND	B11	PF14	A6	V _{DDEXT}	F12
$\overline{AMS3}$	G12	GND	C4	PF15	C6	V _{DDEXT}	G4
\overline{AOE}	G13	GND	C5	PPI_CLK	C9	V _{DDEXT}	J4
ARDY	E13	GND	C11	PPI0	C8	V _{DDEXT}	J12
\overline{ARE}	G14	GND	D4	PPI1	B8	V _{DDEXT}	L7
\overline{AWE}	H14	GND	D7	PPI2	A7	V _{DDEXT}	L11
\overline{BG}	P10	GND	D8	PPI3	B7	V _{DDEXT}	P1
\overline{BGH}	N10	GND	D10	\overline{RESET}	C10	V _{DDINT}	D6
BMODE0	N4	GND	D11	RFS0	J3	V _{DDINT}	E4
BMODE1	P3	GND	F4	RFS1	G2	V _{DDINT}	E11
\overline{BR}	D14	GND	F11	RSCLK0	L1	V _{DDINT}	J11
CLKIN	A12	GND	G11	RSCLK1	G1	V _{DDINT}	L4
CLKOUT	B14	GND	H4	RTXI	A9	V _{DDINT}	L9
DATA0	M9	GND	H11	RTXO	A8	V _{DDRTC}	B9
DATA1	N9	GND	K4	RX	L3	VR0UT0	A13
DATA2	P9	GND	K11	SA10	E12	VR0UT1	B12
DATA3	M8	GND	L5	\overline{SCAS}	C14	XTAL	A11

ADSP-BF531/ADSP-BF532/ADSP-BF533

Table 42. 160-Ball CSP_BGA Ball Assignment (Numerical by Ball Number)

Ball No.	Signal	Ball No.	Signal	Ball No.	Signal	Ball No.	Signal
A1	V _{DDEXT}	C13	\overline{SMS}	H1	DTOPRI	M3	TDI
A2	PF8	C14	\overline{SCAS}	H2	DT0SEC	M4	GND
A3	PF9	D1	SCK	H3	TFS0	M5	DATA12
A4	PF10	D2	PF0	H4	GND	M6	DATA9
A5	PF11	D3	MOSI	H11	GND	M7	DATA6
A6	PF14	D4	GND	H12	$\overline{ABE1}$	M8	DATA3
A7	PPI2	D5	V _{DDEXT}	H13	$\overline{ABE0}$	M9	DATA0
A8	RTXO	D6	V _{DDINT}	H14	\overline{AWE}	M10	GND
A9	RTXI	D7	GND	J1	TSCLK0	M11	ADDR15
A10	GND	D8	GND	J2	DR0SEC	M12	ADDR9
A11	XTAL	D9	V _{DDEXT}	J3	RFS0	M13	ADDR10
A12	CLKIN	D10	GND	J4	V _{DDEXT}	M14	ADDR11
A13	VROUT0	D11	GND	J11	V _{DDINT}	N1	\overline{TRST}
A14	GND	D12	\overline{SWE}	J12	V _{DDEXT}	N2	TMS
B1	PF4	D13	\overline{SRAS}	J13	ADDR4	N3	TDO
B2	PF5	D14	\overline{BR}	J14	ADDR1	N4	BMODE0
B3	PF6	E1	TFS1	K1	DR0PRI	N5	DATA13
B4	PF7	E2	MISO	K2	TMR2	N6	DATA10
B5	PF12	E3	DT1SEC	K3	TX	N7	DATA7
B6	PF13	E4	V _{DDINT}	K4	GND	N8	DATA4
B7	PPI3	E11	V _{DDINT}	K11	GND	N9	DATA1
B8	PPI1	E12	SA10	K12	ADDR7	N10	\overline{BGH}
B9	V _{DDRTC}	E13	ARDY	K13	ADDR5	N11	ADDR16
B10	NMI	E14	$\overline{AMS0}$	K14	ADDR2	N12	ADDR14
B11	GND	F1	TSCLK1	L1	RSCLK0	N13	ADDR13
B12	VROUT1	F2	DT1PRI	L2	TMR0	N14	ADDR12
B13	SCKE	F3	DR1SEC	L3	RX	P1	V _{DDEXT}
B14	CLKOUT	F4	GND	L4	V _{DDINT}	P2	TCK
C1	PF1	F11	GND	L5	GND	P3	BMODE1
C2	PF2	F12	V _{DDEXT}	L6	GND	P4	DATA15
C3	PF3	F13	$\overline{AMS2}$	L7	V _{DDEXT}	P5	DATA14
C4	GND	F14	$\overline{AMS1}$	L8	GND	P6	DATA11
C5	GND	G1	RSCLK1	L9	V _{DDINT}	P7	DATA8
C6	PF15	G2	RFS1	L10	GND	P8	DATA5
C7	V _{DDEXT}	G3	DR1PRI	L11	V _{DDEXT}	P9	DATA2
C8	PPI0	G4	V _{DDEXT}	L12	ADDR8	P10	\overline{BG}
C9	PPI_CLK	G11	GND	L13	ADDR6	P11	ADDR19
C10	\overline{RESET}	G12	$\overline{AMS3}$	L14	ADDR3	P12	ADDR18
C11	GND	G13	\overline{AOE}	M1	TMR1	P13	ADDR17
C12	V _{DDEXT}	G14	\overline{ARE}	M2	\overline{EMU}	P14	GND

ADSP-BF531/ADSP-BF532/ADSP-BF533

Figure 60 shows the top view of the CSP_BGA ball configuration. Figure 61 shows the bottom view of the CSP_BGA ball configuration.



KEY:
 ⊕ V_{DDINT} ● GND ⊕ V_{DDRTC}
 ⊗ V_{DDEXT} ○ I/O ⊗ V_{ROUT}

Figure 60. 160-Ball CSP_BGA Ground Configuration (Top View)

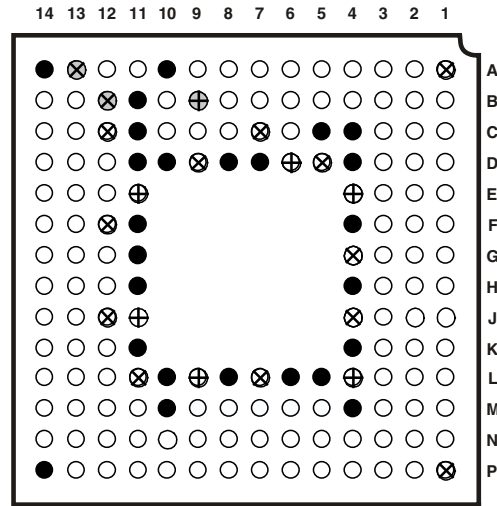

KEY:
 ⊕ V_{DDINT} ● GND ⊕ V_{DDRTC}
 ⊗ V_{DDEXT} ○ I/O ⊗ V_{ROUT}

Figure 61. 160-Ball CSP_BGA Ground Configuration (Bottom View)

169-BALL PBGA BALL ASSIGNMENT

Table 43 lists the PBGA ball assignment by signal. Table 44 on Page 54 lists the PBGA ball assignment by ball number.

Table 43. 169-Ball PBGA Ball Assignment (Alphabetical by Signal)

Signal	Ball No.	Signal	Ball No.	Signal	Ball No.	Signal	Ball No.	Signal	Ball No.
$\overline{ABE0}$	H16	DATA4	U12	GND	K9	RTXI	A10	V_{DDEXT}	K6
$\overline{ABE1}$	H17	DATA5	U11	GND	K10	RTXO	A11	V_{DDEXT}	L6
ADDR1	J16	DATA6	T10	GND	K11	RX	T1	V_{DDEXT}	M6
ADDR2	J17	DATA7	U10	GND	L7	SA10	B15	V_{DDEXT}	M7
ADDR3	K16	DATA8	T9	GND	L8	\overline{SCAS}	A16	V_{DDEXT}	M8
ADDR4	K17	DATA9	U9	GND	L9	SCK	D1	V_{DDEXT}	T2
ADDR5	L16	DATA10	T8	GND	L10	SCKE	B14	VRROUT0	B12
ADDR6	L17	DATA11	U8	GND	L11	\overline{SMS}	A17	VRROUT1	B13
ADDR7	M16	DATA12	U7	GND	M9	\overline{SRAS}	A15	XTAL	A13
ADDR8	M17	DATA13	T7	GND	T16	\overline{SWE}	B17		
ADDR9	N17	DATA14	U6	MISO	E2	TCK	U4		
ADDR10	N16	DATA15	T6	MOSI	E1	TDI	U3		
ADDR11	P17	DR0PRI	M2	NMI	B11	TDO	T4		
ADDR12	P16	DR0SEC	M1	PF0	D2	TFS0	L1		
ADDR13	R17	DR1PRI	H1	PF1	C1	TFS1	G2		
ADDR14	R16	DR1SEC	H2	PF2	B1	TMR0	R1		
ADDR15	T17	DT0PRI	K2	PF3	C2	TMR1	P2		
ADDR16	U15	DT0SEC	K1	PF4	A1	TMR2	P1		
ADDR17	T15	DT1PRI	F1	PF5	A2	TMS	T3		
ADDR18	U16	DT1SEC	F2	PF6	B3	\overline{TRST}	U2		
ADDR19	T14	\overline{EMU}	U1	PF7	A3	TSCLK0	L2		
$\overline{AMS0}$	D17	GND	B16	PF8	B4	TSCLK1	G1		
$\overline{AMS1}$	E16	GND	F11	PF9	A4	TX	R2		
$\overline{AMS2}$	E17	GND	G7	PF10	B5	VDD	F12		
$\overline{AMS3}$	F16	GND	G8	PF11	A5	VDD	G12		
\overline{AOE}	F17	GND	G9	PF12	A6	VDD	H12		
ARDY	C16	GND	G10	PF13	B6	VDD	J12		
\overline{ARE}	G16	GND	G11	PF14	A7	VDD	K12		
\overline{AWE}	G17	GND	H7	PF15	B7	VDD	L12		
\overline{BG}	T13	GND	H8	PPI_CLK	B10	VDD	M10		
\overline{BGH}	U17	GND	H9	PPI0	B9	VDD	M11		
BMODE0	U5	GND	H10	PPI1	A9	VDD	M12		
BMODE1	T5	GND	H11	PPI2	B8	V_{DDEXT}	B2		
\overline{BR}	C17	GND	J7	PPI3	A8	V_{DDEXT}	F6		
CLKIN	A14	GND	J8	\overline{RESET}	A12	V_{DDEXT}	F7		
CLKOUT	D16	GND	J9	RFS0	N1	V_{DDEXT}	F8		
DATA0	U14	GND	J10	RFS1	J1	V_{DDEXT}	F9		
DATA1	T12	GND	J11	RSCLK0	N2	V_{DDEXT}	G6		
DATA2	U13	GND	K7	RSCLK1	J2	V_{DDEXT}	H6		
DATA3	T11	GND	K8	RTCVDD	F10	V_{DDEXT}	J6		

ADSP-BF531/ADSP-BF532/ADSP-BF533

Table 44. 169-Ball PBGA Ball Assignment (Numerical by Ball Number)

Ball No.	Signal	Ball No.	Signal	Ball No.	Signal	Ball No.	Signal	Ball No.	Signal
A1	PF4	D16	CLKOUT	J2	RSCLK1	M12	VDD	U9	DATA9
A2	PF5	D17	AMS0	J6	V _{DDEXT}	M16	ADDR7	U10	DATA7
A3	PF7	E1	MOSI	J7	GND	M17	ADDR8	U11	DATA5
A4	PF9	E2	MISO	J8	GND	N1	RFS0	U12	DATA4
A5	PF11	E16	AMS1	J9	GND	N2	RSCLK0	U13	DATA2
A6	PF12	E17	AMS2	J10	GND	N16	ADDR10	U14	DATA0
A7	PF14	F1	DT1PRI	J11	GND	N17	ADDR9	U15	ADDR16
A8	PPI3	F2	DT1SEC	J12	VDD	P1	TMR2	U16	ADDR18
A9	PPI1	F6	V _{DDEXT}	J16	ADDR1	P2	TMR1	U17	BGH
A10	RTXI	F7	V _{DDEXT}	J17	ADDR2	P16	ADDR12		
A11	RTXO	F8	V _{DDEXT}	K1	DT0SEC	P17	ADDR11		
A12	RESET	F9	V _{DDEXT}	K2	DT0PRI	R1	TMR0		
A13	XTAL	F10	RTCVDD	K6	V _{DDEXT}	R2	TX		
A14	CLKIN	F11	GND	K7	GND	R16	ADDR14		
A15	SRAS	F12	VDD	K8	GND	R17	ADDR13		
A16	SCAS	F16	AMS3	K9	GND	T1	RX		
A17	SM \bar{S}	F17	AOE	K10	GND	T2	V _{DDEXT}		
B1	PF2	G1	TSCLK1	K11	GND	T3	TMS		
B2	V _{DDEXT}	G2	TFS1	K12	VDD	T4	TDO		
B3	PF6	G6	V _{DDEXT}	K16	ADDR3	T5	BMODE1		
B4	PF8	G7	GND	K17	ADDR4	T6	DATA15		
B5	PF10	G8	GND	L1	TFS0	T7	DATA13		
B6	PF13	G9	GND	L2	TSCLK0	T8	DATA10		
B7	PF15	G10	GND	L6	V _{DDEXT}	T9	DATA8		
B8	PPI2	G11	GND	L7	GND	T10	DATA6		
B9	PPI0	G12	VDD	L8	GND	T11	DATA3		
B10	PPI_CLK	G16	ARE	L9	GND	T12	DATA1		
B11	NMI	G17	AWE	L10	GND	T13	BG		
B12	VROUT0	H1	DR1PRI	L11	GND	T14	ADDR19		
B13	VROUT1	H2	DR1SEC	L12	VDD	T15	ADDR17		
B14	SCKE	H6	V _{DDEXT}	L16	ADDR5	T16	GND		
B15	SA10	H7	GND	L17	ADDR6	T17	ADDR15		
B16	GND	H8	GND	M1	DR0SEC	U1	EMU		
B17	SWE	H9	GND	M2	DR0PRI	U2	TRST		
C1	PF1	H10	GND	M6	V _{DDEXT}	U3	TDI		
C2	PF3	H11	GND	M7	V _{DDEXT}	U4	TCK		
C16	ARDY	H12	VDD	M8	V _{DDEXT}	U5	BMODE0		
C17	BR	H16	ABE0	M9	GND	U6	DATA14		
D1	SCK	H17	ABE1	M10	VDD	U7	DATA12		
D2	PF0	J1	RFS1	M11	VDD	U8	DATA11		

ADSP-BF531/ADSP-BF532/ADSP-BF533

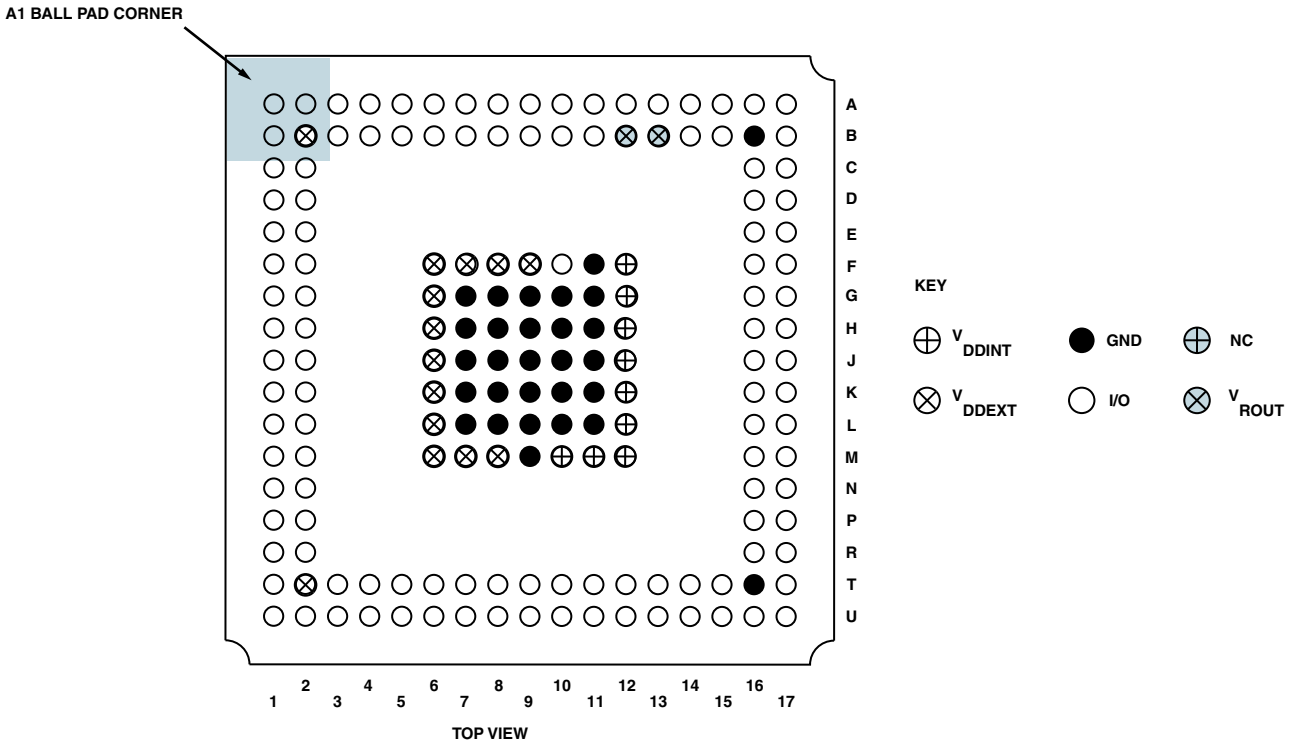

Figure 62. 169-Ball PBGA Ground Configuration (Top View)

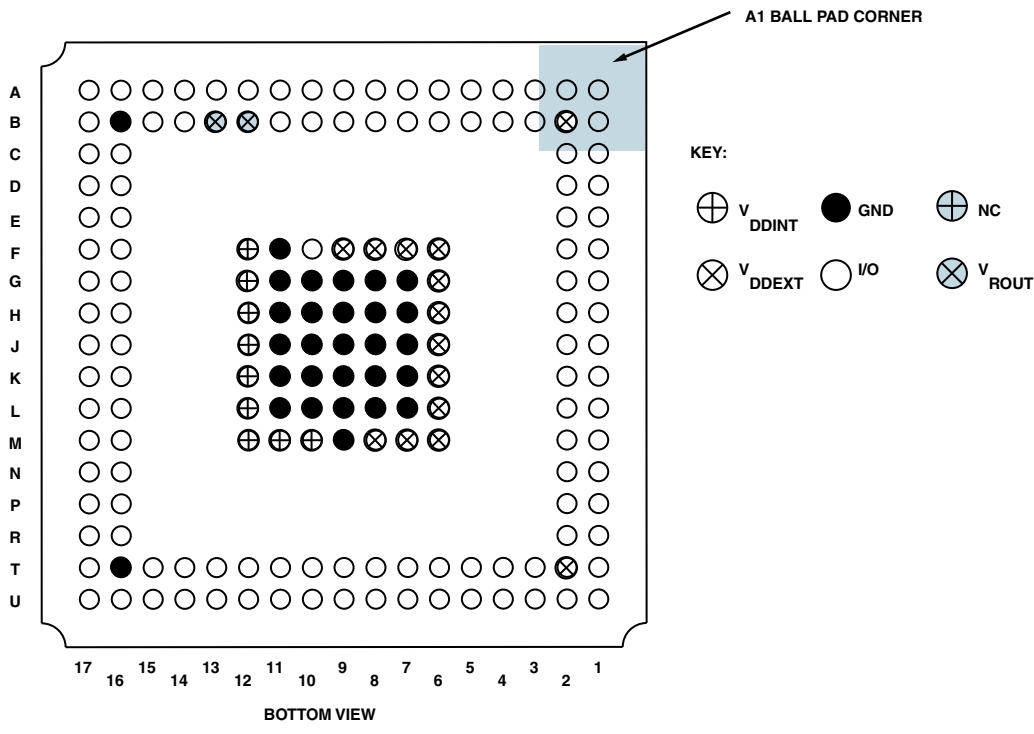

Figure 63. 169-Ball PBGA Ground Configuration (Bottom View)

ADSP-BF531/ADSP-BF532/ADSP-BF533

176-LEAD LQFP PINOUT

Table 45 lists the LQFP pinout by signal. Table 46 on Page 57 lists the LQFP pinout by lead number.

Table 45. 176-Lead LQFP Pin Assignment (Alphabetical by Signal)

Signal	Lead No.	Signal	Lead No.	Signal	Lead No.	Signal	Lead No.	Signal	Lead No.
$\overline{ABE0}$	151	DATA3	113	GND	88	PPI_CLK	21	V _{DDEXT}	71
$\overline{ABE1}$	150	DATA4	112	GND	89	PPI0	22	V _{DDEXT}	93
ADDR1	149	DATA5	110	GND	90	PPI1	23	V _{DDEXT}	107
ADDR2	148	DATA6	109	GND	91	PPI2	24	V _{DDEXT}	118
ADDR3	147	DATA7	108	GND	92	PPI3	26	V _{DDEXT}	134
ADDR4	146	DATA8	105	GND	97	\overline{RESET}	13	V _{DDEXT}	145
ADDR5	142	DATA9	104	GND	106	RFS0	75	V _{DDEXT}	156
ADDR6	141	DATA10	103	GND	117	RFS1	64	V _{DDEXT}	171
ADDR7	140	DATA11	102	GND	128	RSCLK0	76	V _{DDINT}	25
ADDR8	139	DATA12	101	GND	129	RSCLK1	65	V _{DDINT}	52
ADDR9	138	DATA13	100	GND	130	RTXI	17	V _{DDINT}	66
ADDR10	137	DATA14	99	GND	131	RTXO	16	V _{DDINT}	80
ADDR11	136	DATA15	98	GND	132	RX	82	V _{DDINT}	111
ADDR12	135	DR0PRI	74	GND	133	SA10	164	V _{DDINT}	143
ADDR13	127	DR0SEC	73	GND	144	\overline{SCAS}	166	V _{DDINT}	157
ADDR14	126	DR1PRI	63	GND	155	SCK	53	V _{DDINT}	168
ADDR15	125	DR1SEC	62	GND	170	SCKE	173	V _{DDRTC}	18
ADDR16	124	DTOPRI	68	GND	174	\overline{SMS}	172	VROUT0	5
ADDR17	123	DT0SEC	67	GND	175	$\overline{SRA5}$	167	VROUT1	4
ADDR18	122	DT1PRI	59	GND	176	\overline{SWE}	165	XTAL	11
ADDR19	121	DT1SEC	58	MISO	54	TCK	94		
$\overline{AMS0}$	161	\overline{EMU}	83	MOSI	55	TDI	86		
$\overline{AMS1}$	160	GND	1	NMI	14	TDO	87		
$\overline{AMS2}$	159	GND	2	PF0	51	TFS0	69		
$\overline{AMS3}$	158	GND	3	PF1	50	TFS1	60		
\overline{AOE}	154	GND	7	PF2	49	TMRO	79		
ARDY	162	GND	8	PF3	48	TMR1	78		
\overline{ARE}	153	GND	9	PF4	47	TMR2	77		
\overline{AWE}	152	GND	15	PF5	46	TMS	85		
\overline{BG}	119	GND	19	PF6	38	\overline{TRST}	84		
\overline{BGH}	120	GND	30	PF7	37	TSCLK0	72		
BMODE0	96	GND	39	PF8	36	TSCLK1	61		
BMODE1	95	GND	40	PF9	35	TX	81		
\overline{BR}	163	GND	41	PF10	34	V _{DDEXT}	6		
CLKIN	10	GND	42	PF11	33	V _{DDEXT}	12		
CLKOUT	169	GND	43	PF12	32	V _{DDEXT}	20		
DATA0	116	GND	44	PF13	29	V _{DDEXT}	31		
DATA1	115	GND	56	PF14	28	V _{DDEXT}	45		
DATA2	114	GND	70	PF15	27	V _{DDEXT}	57		

ADSP-BF531/ADSP-BF532/ADSP-BF533

Table 46. 176-Lead LQFP Pin Assignment (Numerical by Lead Number)

Lead No.	Signal	Lead No.	Signal	Lead No.	Signal	Lead No.	Signal	Lead No.	Signal
1	GND	41	GND	81	TX	121	ADDR19	161	AMS0
2	GND	42	GND	82	RX	122	ADDR18	162	ARDY
3	GND	43	GND	83	EMU	123	ADDR17	163	BR
4	VROUT1	44	GND	84	TRST	124	ADDR16	164	SA10
5	VROUT0	45	V _{DDEXT}	85	TMS	125	ADDR15	165	SWE
6	V _{DDEXT}	46	PF5	86	TDI	126	ADDR14	166	SCAS
7	GND	47	PF4	87	TDO	127	ADDR13	167	SRAS
8	GND	48	PF3	88	GND	128	GND	168	V _{DDINT}
9	GND	49	PF2	89	GND	129	GND	169	CLKOUT
10	CLKIN	50	PF1	90	GND	130	GND	170	GND
11	XTAL	51	PF0	91	GND	131	GND	171	V _{DDEXT}
12	V _{DDEXT}	52	V _{DDINT}	92	GND	132	GND	172	SMS
13	RESET	53	SCK	93	V _{DDEXT}	133	GND	173	SCKE
14	NMI	54	MISO	94	TCK	134	V _{DDEXT}	174	GND
15	GND	55	MOSI	95	BMODE1	135	ADDR12	175	GND
16	RTXO	56	GND	96	BMODE0	136	ADDR11	176	GND
17	RTXI	57	V _{DDEXT}	97	GND	137	ADDR10		
18	V _{DDRTC}	58	DT1SEC	98	DATA15	138	ADDR9		
19	GND	59	DT1PRI	99	DATA14	139	ADDR8		
20	V _{DDEXT}	60	TFS1	100	DATA13	140	ADDR7		
21	PPI_CLK	61	TSCLK1	101	DATA12	141	ADDR6		
22	PPI0	62	DR1SEC	102	DATA11	142	ADDR5		
23	PPI1	63	DR1PRI	103	DATA10	143	V _{DDINT}		
24	PPI2	64	RFS1	104	DATA9	144	GND		
25	V _{DDINT}	65	RSCLK1	105	DATA8	145	V _{DDEXT}		
26	PPI3	66	V _{DDINT}	106	GND	146	ADDR4		
27	PF15	67	DT0SEC	107	V _{DDEXT}	147	ADDR3		
28	PF14	68	DT0PRI	108	DATA7	148	ADDR2		
29	PF13	69	TFS0	109	DATA6	149	ADDR1		
30	GND	70	GND	110	DATA5	150	ABE1		
31	V _{DDEXT}	71	V _{DDEXT}	111	V _{DDINT}	151	ABE0		
32	PF12	72	TSCLK0	112	DATA4	152	AWE		
33	PF11	73	DR0SEC	113	DATA3	153	ARE		
34	PF10	74	DR0PRI	114	DATA2	154	AOE		
35	PF9	75	RFS0	115	DATA1	155	GND		
36	PF8	76	RSCLK0	116	DATA0	156	V _{DDEXT}		
37	PF7	77	TMR2	117	GND	157	V _{DDINT}		
38	PF6	78	TMR1	118	V _{DDEXT}	158	AMS3		
39	GND	79	TMRO	119	BG	159	AMS2		
40	GND	80	V _{DDINT}	120	BGH	160	AMS1		

ADSP-BF531/ADSP-BF532/ADSP-BF533

OUTLINE DIMENSIONS

Dimensions in the outline dimension figures are shown in millimeters.



COMPLIANT TO JEDEC STANDARDS MS-026-BGA

Figure 64. 176-Lead Low Profile Quad Flat Package [LQFP]
(ST-176-1)
Dimensions shown in millimeters

ADSP-BF531/ADSP-BF532/ADSP-BF533

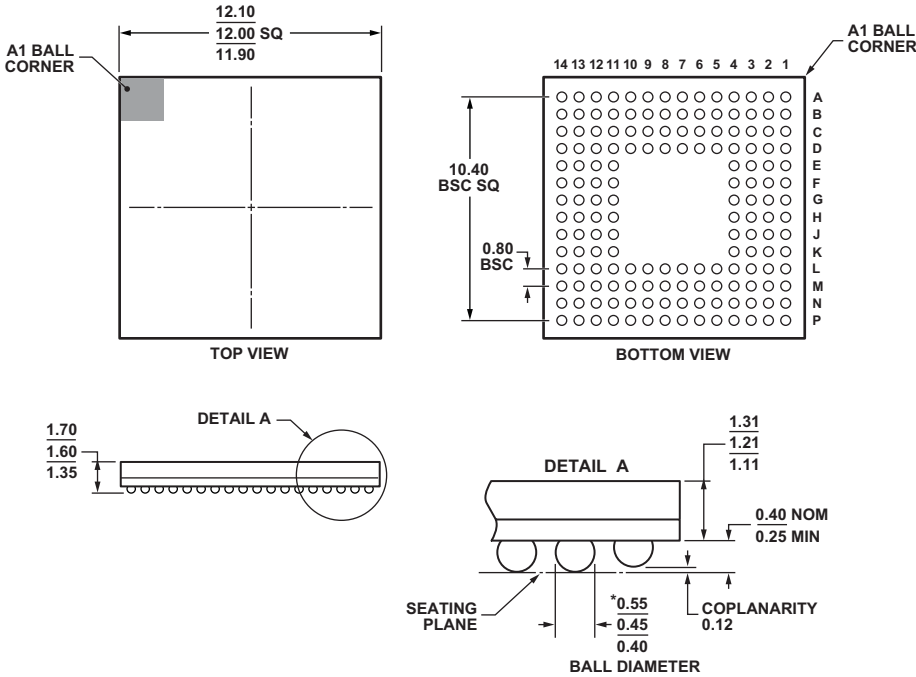

*COMPLIANT TO JEDEC STANDARDS MO-205-AE WITH THE EXCEPTION TO BALL DIAMETER.

Figure 65. 160-Ball Chip Scale Package Ball Grid Array [CSP_BGA] (BC-160-2)
Dimensions shown in millimeters

ADSP-BF531/ADSP-BF532/ADSP-BF533

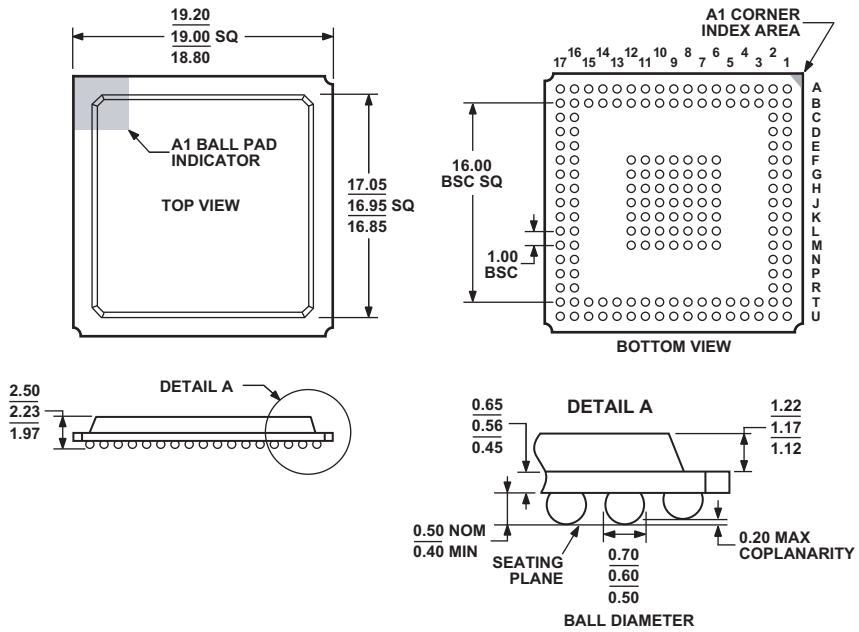

COMPLIANT TO JEDEC STANDARDS MS-034-AAG-2

Figure 66. 169-Ball Plastic Ball Grid Array [PBGA]
(B-169)

Dimensions shown in millimeters

SURFACE-MOUNT DESIGN

Table 47 is provided as an aid to PCB design. For industry-standard design recommendations, refer to IPC-7351, *Generic Requirements for Surface-Mount Design and Land Pattern Standard*.

Table 47. BGA Data for Use with Surface-Mount Design

Package	Ball Attach Type	Solder Mask Opening	Ball Pad Size
Chip Scale Package Ball Grid Array (CSP_BGA) BC-160-2	Solder Mask Defined	0.40 mm diameter	0.55 mm diameter
Plastic Ball Grid Array (PBGA) B-169	Solder Mask Defined	0.43 mm diameter	0.56 mm diameter

ADSP-BF531/ADSP-BF532/ADSP-BF533

AUTOMOTIVE PRODUCTS

The ADBF531W, ADBF532W, and ADBF533W models are available with controlled manufacturing to support the quality and reliability requirements of automotive applications. Note that these automotive models may have specifications that differ from the commercial models and designers should review the [Specifications](#) section of this data sheet carefully. Only the auto-

motive grade products shown in [Table 48](#) are available for use in automotive applications. Contact your local ADI account representative for specific product ordering information and to obtain the specific Automotive Reliability reports for these models.

Table 48. Automotive Products

Product Family ^{1,2}	Temperature Range ³	Speed Grade (Max)	Package Description	Package Option
ADBF531WBSTZ4xx	-40°C to +85°C	400 MHz	176-Lead LQFP	ST-176-1
ADBF531WBBCZ4xx	-40°C to +85°C	400 MHz	160-Ball CSP_BGA	BC-160-2
ADBF531WYBCZ4xx	-40°C to +105°C	400 MHz	160-Ball CSP_BGA	BC-160-2
ADBF532WBSTZ4xx	-40°C to +85°C	400 MHz	176-Lead LQFP	ST-176-1
ADBF532WBBCZ4xx	-40°C to +85°C	400 MHz	160-Ball CSP_BGA	BC-160-2
ADBF532WYBCZ4xx	-40°C to +105°C	400 MHz	160-Ball CSP_BGA	BC-160-2
ADBF533WBBCZ5xx	-40°C to +85°C	533 MHz	160-Ball CSP_BGA	BC-160-2
ADBF533WBBZ5xx	-40°C to +85°C	533 MHz	169-Ball PBGA	B-169
ADBF533WYBCZ4xx	-40°C to +105°C	400 MHz	160-Ball CSP_BGA	BC-160-2
ADBF533WYBBZ4xx	-40°C to +105°C	400 MHz	169-Ball PBGA	B-169

¹ Z = RoHS compliant part.

² xx denotes silicon revision.

³ Referenced temperature is ambient temperature. The ambient temperature is not a specification. Please see [Operating Conditions on Page 20](#) for junction temperature (T_j) specification which is the only temperature specification.

ADSP-BF531/ADSP-BF532/ADSP-BF533

ORDERING GUIDE

Model ¹	Temperature Range ²	Speed Grade (Max)	Package Description	Package Option
ADSP-BF531SBB400	-40°C to +85°C	400 MHz	169-Ball PBGA	B-169
ADSP-BF531SBBZ400	-40°C to +85°C	400 MHz	169-Ball PBGA	B-169
ADSP-BF531SBBC400	-40°C to +85°C	400 MHz	160-Ball CSP_BGA	BC-160-2
ADSP-BF531SBBCZ400	-40°C to +85°C	400 MHz	160-Ball CSP_BGA	BC-160-2
ADSP-BF531SBBCZ4RL	-40°C to +85°C	400 MHz	160-Ball CSP_BGA, 13" Tape and Reel	BC-160-2
ADSP-BF531SBSTZ400	-40°C to +85°C	400 MHz	176-Lead LQFP	ST-176-1
ADSP-BF532SBBZ400	-40°C to +85°C	400 MHz	169-Ball PBGA	B-169
ADSP-BF532SBBC400	-40°C to +85°C	400 MHz	160-Ball CSP_BGA	BC-160-2
ADSP-BF532SBBCZ400	-40°C to +85°C	400 MHz	160-Ball CSP_BGA	BC-160-2
ADSP-BF532SBSTZ400	-40°C to +85°C	400 MHz	176-Lead LQFP	ST-176-1
ADSP-BF533SBBZ400	-40°C to +85°C	400 MHz	169-Ball PBGA	B-169
ADSP-BF533SBBC400	-40°C to +85°C	400 MHz	160-Ball CSP_BGA	BC-160-2
ADSP-BF533SBBCZ400	-40°C to +85°C	400 MHz	160-Ball CSP_BGA	BC-160-2
ADSP-BF533SBSTZ400	-40°C to +85°C	400 MHz	176-Lead LQFP	ST-176-1
ADSP-BF533SBB500	-40°C to +85°C	500 MHz	169-Ball PBGA	B-169
ADSP-BF533SBBZ500	-40°C to +85°C	500 MHz	169-Ball PBGA	B-169
ADSP-BF533SBBC500	-40°C to +85°C	500 MHz	160-Ball CSP_BGA	BC-160-2
ADSP-BF533SBBCZ500	-40°C to +85°C	500 MHz	160-Ball CSP_BGA	BC-160-2
ADSP-BF533SBBC-5V	-40°C to +85°C	533 MHz	160-Ball CSP_BGA	BC-160-2
ADSP-BF533SBBCZ-5V	-40°C to +85°C	533 MHz	160-Ball CSP_BGA	BC-160-2
ADSP-BF533SKBC-6V	0°C to +70°C	600 MHz	160-Ball CSP_BGA	BC-160-2
ADSP-BF533SKBCZ-6V	0°C to +70°C	600 MHz	160-Ball CSP_BGA	BC-160-2
ADSP-BF533SKSTZ-5V	0°C to +70°C	533 MHz	176-Lead LQFP	ST-176-1

¹ Z = RoHS compliant part.

² Referenced temperature is ambient temperature. The ambient temperature is not a specification. Please see [Operating Conditions on Page 20](#) for junction temperature (T_J) specification which is the only temperature specification.

ADSP-BF531/ADSP-BF532/ADSP-BF533

Looking for pricing, stock, or lifecycle information?

Click below to explore more details on WIN SOURCE:

- ⊖ [View ADSP-BF531SBBCZ400 on WIN SOURCE](#)
- ⊖ [Analog Devices Inc. Information](#)

Optimize Your Supply Chain with WIN SOURCE Solutions

- ✓ Global Sourcing Solution
- ✓ Obsolete Management
- ✓ Cost Control Management
- ✓ Shortage Management
- ✓ Alternative Solution
- ✓ Excess Inventory Management