



Is Now Part of



ON Semiconductor®

To learn more about ON Semiconductor, please visit our website at
www.onsemi.com

Please note: As part of the Fairchild Semiconductor integration, some of the Fairchild orderable part numbers will need to change in order to meet ON Semiconductor's system requirements. Since the ON Semiconductor product management systems do not have the ability to manage part nomenclature that utilizes an underscore (_), the underscore (_) in the Fairchild part numbers will be changed to a dash (-). This document may contain device numbers with an underscore (_). Please check the ON Semiconductor website to verify the updated device numbers. The most current and up-to-date ordering information can be found at www.onsemi.com. Please email any questions regarding the system integration to Fairchild_questions@onsemi.com.

ON Semiconductor and the ON Semiconductor logo are trademarks of Semiconductor Components Industries, LLC dba ON Semiconductor or its subsidiaries in the United States and/or other countries. ON Semiconductor owns the rights to a number of patents, trademarks, copyrights, trade secrets, and other intellectual property. A listing of ON Semiconductor's product/patent coverage may be accessed at www.onsemi.com/site/pdf/Patent-Marking.pdf. ON Semiconductor reserves the right to make changes without further notice to any products herein. ON Semiconductor makes no warranty, representation or guarantee regarding the suitability of its products for any particular purpose, nor does ON Semiconductor assume any liability arising out of the application or use of any product or circuit, and specifically disclaims any and all liability, including without limitation special, consequential or incidental damages. Buyer is responsible for its products and applications using ON Semiconductor products, including compliance with all laws, regulations and safety requirements or standards, regardless of any support or applications information provided by ON Semiconductor. "Typical" parameters which may be provided in ON Semiconductor data sheets and/or specifications can and do vary in different applications and actual performance may vary over time. All operating parameters, including "Typicals" must be validated for each customer application by customer's technical experts. ON Semiconductor does not convey any license under its patent rights nor the rights of others. ON Semiconductor products are not designed, intended, or authorized for use as a critical component in life support systems or any FDA Class 3 medical devices or medical devices with a same or similar classification in a foreign jurisdiction or any devices intended for implantation in the human body. Should Buyer purchase or use ON Semiconductor products for any such unintended or unauthorized application, Buyer shall indemnify and hold ON Semiconductor and its officers, employees, subsidiaries, affiliates, and distributors harmless against all claims, costs, damages, and expenses, and reasonable attorney fees arising out of, directly or indirectly, any claim of personal injury or death associated with such unintended or unauthorized use, even if such claim alleges that ON Semiconductor was negligent regarding the design or manufacture of the part. ON Semiconductor is an Equal Opportunity/Affirmative Action Employer. This literature is subject to all applicable copyright laws and is not for resale in any manner.

FSA2367 — Low R_{ON} (0.75Ω) Triple-SPDT, Negative-Swing Audio Source Switch

Features

- 10μA Maximum I_{CCT} Current Over Expanded Control Voltage Range (V_{IN}=2.6V, V_{CC}=4.3V)
- On Capacitance 55pF Typical (C_{ON})
- 0.75Ω Typical On Resistance (R_{ON})
- Common Ports 1A, 2A, 3A with Negative Swing Audio to -2V
- -3db Bandwidth: >150 MHz
- Low Power Consumption (1μA Maximum)
- Power-Off Feature for 1A/2A/3A Pin (I_{IN} < 2μA)
- Packaged in Pb-Free 14-Pin TSSOP and DQFN

Description

The FSA2367 is a triple Single-Pole Double-Throw (SPDT) switch that multiplexes three sources of data or audio under independent control pins. The FSA2367 has special circuitry on the 1A, 2A, 3A pins that allows a power-off feature. With the V_{CC} supply removed and a voltage on the 1A/2A/3A pins, there is minimal leakage current into the 1A/2A/3A data pins. In addition, the FSA2367 also features very low quiescent current to extend battery life. The low quiescent current allows mobile handset applications direct interface with the baseband processor general-purpose I/Os. Typical applications involve switching in portables and consumer applications such as cell phones, digital cameras, and notebooks with hubs or controllers.

Applications

- Cell Phone, PDA, Digital Camera, and Notebook
- LCD Monitor, TV, and Set-Top Box

IMPORTANT NOTE:

For additional information, please contact analogswitch@fairchildsemi.com.

Ordering Information

Part Number	Top Mark	Eco Status	Package
FSA2367BQX	2367	Green	14-Terminal Depopulated very thin Quad Flat-pack No leads (DQFN) 2.5 x 3.0mm, JEDEC MO-241
FSA2367MTCX	FSA2367	RoHS	14-Lead Thin Shrink Small Outline Package (TSSOP), 4.4mm Wide, JEDEC MO-153

For Fairchild's definition of Eco Status, please visit: http://www.fairchildsemi.com/company/green/rohs_green.html.

Analog Symbol

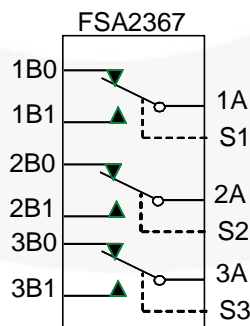

Figure 1. Analog Symbol

Pin Assignments

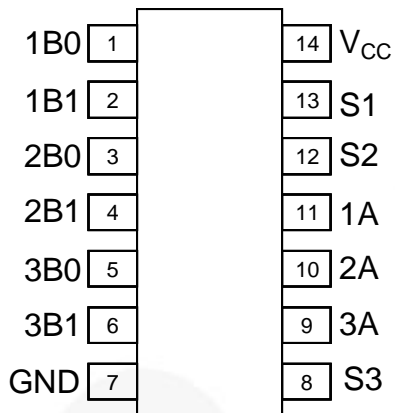

Figure 2. Pin Assignment TSSOP-14 (Top View)

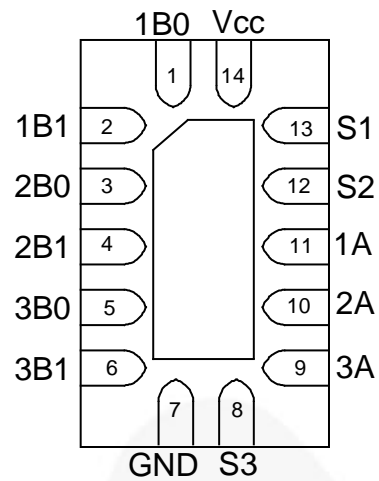

Figure 3. Pad Assignment DQFN-14 (Top View)

Pin Descriptions

Pin Name	Description
S1, S2, S3	Switch Control Selects
1A, 2A, 3A	A Data Bus (Common)
1Bn, 2Bn, 3Bn	Multiplexed Source inputs

Truth Table

S1, S2, S3	Function
LOW	1B0=1A; 2B0=2A; 3B0=3A
HIGH	1B1=1A; 2B1=2A; 3B1=3A

Absolute Maximum Ratings

Stresses exceeding the absolute maximum ratings may damage the device. The device may not function or be operable above the recommended operating conditions and stressing the parts to these levels is not recommended. In addition, extended exposure to stresses above the recommended operating conditions may affect device reliability. The absolute maximum ratings are stress ratings only.

Symbol	Parameter	Conditions	Min.	Max.	Unit
V _{CC}	Supply Voltages		-0.5	6.0	V
V _{SW}	Switch I/O Voltage ⁽¹⁾	1Bn, 2Bn Pins	V _{CC} -5.5V	V _{CC} -0.3V	V
		1A, 2A Pins	V _{CC} -5.5V	V _{CC} -0.3V	V
V _{CNTRL}	Control Input Voltage ⁽¹⁾	S0, S1	-0.5	6.0	V
	Input Clamp Diode Current		-50		mA
	Switch I/O Current	Continuous		350	mA
	Peak Switch Current	Pulsed at 1ms duration, <10% Duty Cycle		500	mA
P _D	Power Dissipation at 85°C	DQFN14 package		2.5	μW
		TSSOP14 package		2.5	μW
T _{STG}	Storage Temperature Range		-65	+150	°C
T _J	Maximum Junction Temperature			+150	°C
T _L	Lead Temperature	Soldering, 10 seconds		+260	°C
ESD	Human Body Model (JEDEC: JESD22-A114)	All Pins		5500	kV
		I/O to GND		8000	
		VCC to GND		8000	
	Charged Device Model (JEDEC-JESD22-C101)			2000	kV

Note:

- Input and output negative ratings may be exceeded if input and output diode current ratings are observed.

Recommended Operating Conditions

The Recommended Operating Conditions table defines the conditions for actual device operation. Recommended operating conditions are specified to ensure optimal performance to the datasheet specifications. Fairchild does not recommend exceeding them or designing to absolute maximum ratings.

Symbol	Parameter	Min.	Max.	Unit
V _{CC}	Supply Voltages	2.7	4.3	V
V _{S0:S1}	Control Input Voltage	0	V _{CC}	V
V _{SW}	Switch I/O Voltage	V _{CC} -5.5	V _{CC} -0.3	V
T _A	Operating Temperature	-40	+85	°C
θ _{JA}	Thermal Resistance (free air)		145	°C/W

DC Electrical Characteristics

All typical values are at 25°C unless otherwise specified.

Symbol	Parameter	Conditions	V _{CC} (V)	T _A =- 40°C to +85°C			Unit
				Min.	Typ.	Max.	
	Analog Signal Range			V _{CC} -5.5		V _{CC}	V
V _{IK}	Clamp Diode Voltage	I _{IN} =-18mA	3.0			-1.2	V
V _{IH}	Input Voltage High		2.7 to 3.6	1.2			V
			3.6 to 4.3	1.5			
V _{IL}	Input Voltage Low		2.7 to 3.6			0.5	V
			3.6 to 4.3			0.7	
I _{IN}	Control Input Leakage	V _{IN} =0 to V _{CC}	4.3			±1	μA
I _{OFF}	Power-Off Leakage Current (Common Port Only 1A, 2A)	Common Port (1A, 2A), V _{SW} =0 to 4.3V, V _{CC} =0V	0V			±10	μA
I _{NO(OFF)}	Off-Leakage Current of Port 1Bn, 2Bn	1Bn, 2Bn=0.5V, V _{CC} - 0.5V or Floating 1A, 2A=0.5V, V _{CC} - 0.5V Figure 8	4.3	-250	10	250	nA
I _{NC(ON)}	On-Leakage Current of Port 1Bn, 2Bn	1Bn, 2Bn=Floating 1A, 2A=0.5V, V _{CC} - 0.5V Figure 10	4.3	-250	10	250	nA
R _{ON}	Switch On Resistance ⁽²⁾	1Bn or 2Bn=0V, 0.7V, 2.0V, 2.7V, I _{ON} =-100m Figure 9	2.7		0.75	2.00	Ω
ΔR _{ON}	Delta R _{ON} ⁽³⁾	1Bn or 2Bn=0.7V, I _{ON} =-100mA	2.7		0.5		Ω
R _{FLAT(ON)}	On Resistance Flatness ⁽⁴⁾	1Bn or 2Bn=0V, 0.7V, 2.0V, 2.7V, I _{ON} =-100mA	2.7 to 4.3		0.23	0.40	Ω
I _{CC}	Quiescent Supply Current	V _{SW} =0 or V _{CC} , I _{OUT} =0	4.3			500	nA
I _{CCT}	Increase in I _{CC} Current per Control Voltage and V _{CC}	V _{CNTRL} =2.6V	4.3		2.2	10.0	μA
		V _{CNTRL} =1.8V	4.3		6.5	15.0	

Notes:

- Measured by the voltage drop between the 1Bn (2Bn, 3Bn) and 1A (2A, 3A) pins at the indicated current through the switch. On resistance is determined by the lower voltage on the two.
- Guaranteed by characterization; not tested in production.
- Flatness is defined as the difference between minimum and maximum on resistance over the specified range.

AC Electrical Characteristics

All typical values are for $V_{CC}=3.3V$ at $25^{\circ}C$ unless otherwise specified.

Symbol	Parameter	Conditions	Vcc (V)	$T_A=-40^{\circ}C$ to $+85^{\circ}C$			Unit
				Min.	Typ.	Max.	
t_{ON}	Turn-On Time, S to Output	$V_{Bn}=1.5V$, $R_L=50\Omega$, $C_L=35pF$ Figure 10, Figure 12	2.7 to 4.3		45	60	ns
t_{OFF}	Turn-Off Time, S to Output	$V_{Bn}=1.5V$, $R_L=50\Omega$, $C_L=35pF$ Figure 10, Figure 12	2.7 to 4.3		25	45	ns
t_{PD}	Propagation Delay ⁽⁵⁾	$R_L=50\Omega$, $C_L=5pF$ Figure 10, Figure 13	3.3		0.25		ns
t_{BBM}	Break-Before-Make ⁽⁵⁾	$R_L=50\Omega$, $C_L=35pF$ $V_{IN1}=V_{IN2}=V_{IN3}=1.5V$ Figure 11	2.7 to 4.3	1	6		ns
Q	Charge Injection	$R_{GEN}=0\Omega$, $C_L=100pF$, $R_L=OPEN$; $V_{GEN}=0V$ Figure 14	2.7 to 4.3		9		pC
O_{IRR}	Off-Isolation	$f=100$ kHz, $R_L=50\Omega$ Figure 4, Figure 16	2.7 to 4.3		-70		dB
Xtalk	Non-Adjacent Channel Crosstalk	$f=100$ kHz, $R_L=50\Omega$ Figure 5, Figure 17	2.7 to 4.3		-100		dB
THD	Total Harmonic Distortion	$R_L=600\Omega$, $V_{SW}=0.5V_{pp}$, $f=20$ Hz to 20kHz Figure 20	2.7 to 4.3		0.01		%
BW	-3db bandwidth	$R_L=50\Omega$, $C_L=0$, 5pF Figure 6, Figure 15	2.7 to 4.3		150		MHz

Note:

5. Guaranteed by characterization; not tested in production.

Capacitance

Symbol	Parameter	Conditions	$T_A=-40^{\circ}C$ to $+85^{\circ}C$			Unit
			Min.	Typ.	Max.	
C_{IN}	Control Pin Input Capacitance	$V_{CC}=0V$		2.5		pF
C_{ON}	A/B On Capacitance	$V_{CC}=3.3$, $f=1MHz$ Figure 19			55	
C_{OFFB}	Port 1Bn, 2Bn,3Bn Off Capacitance	$V_{CC}=3.3$, $f=1MHz$ Figure 18			16	
C_{OFFA}	Port 1A, 2A,3A Off Capacitance	$V_{CC}=3.3$, $f=1MHz$ Figure 18			20	

Typical Performance Characteristics

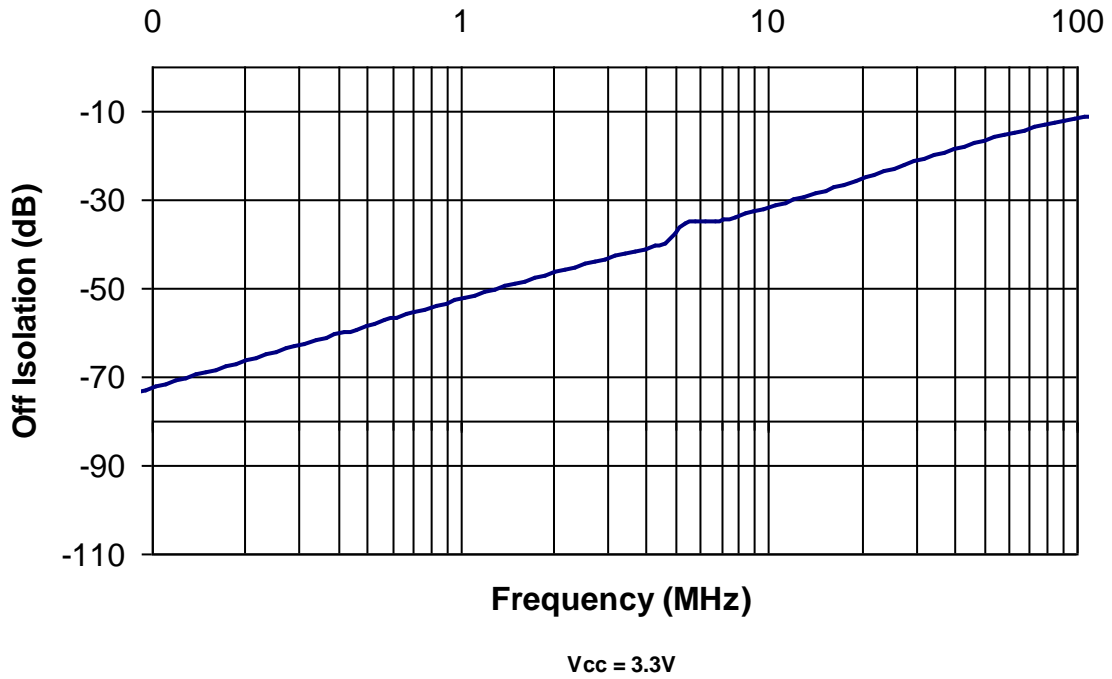

Figure 4. Off Isolation $V_{CC}=3.3V$, $C_L=0pF$

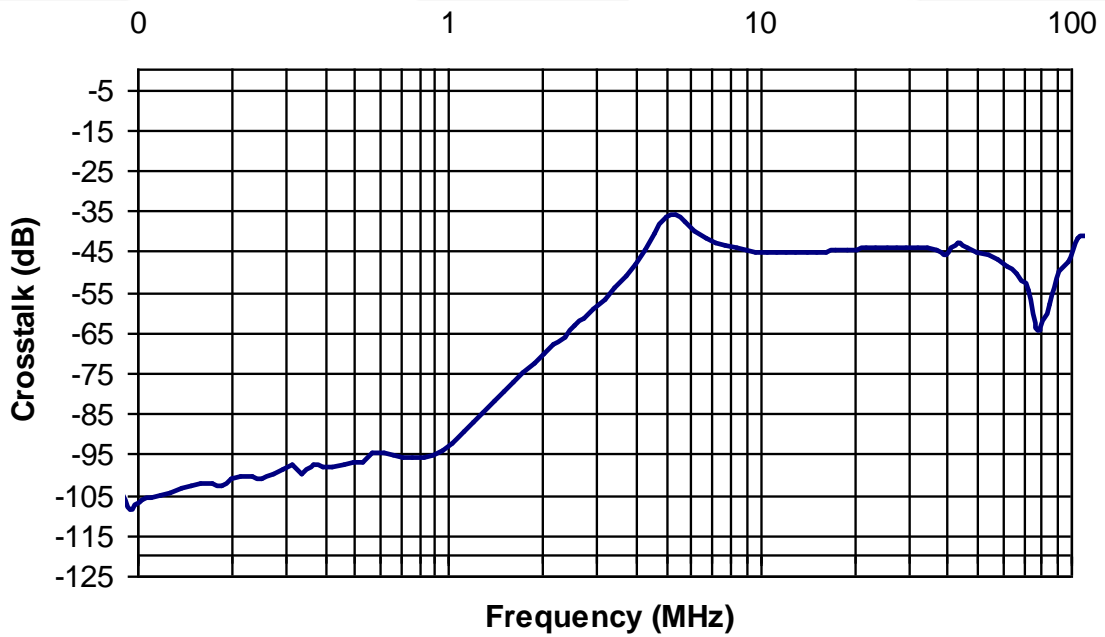

Figure 5. Non-Adjacent Crosstalk $V_{CC}=3.3$, $C_L=0pF$

Typical Performance Characteristics (Continued)

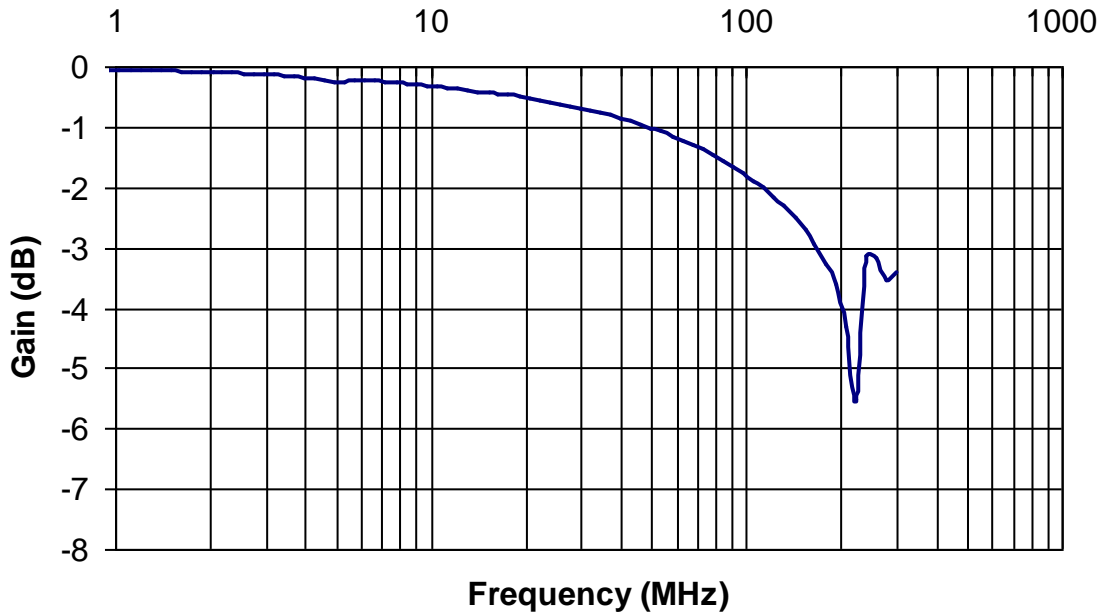

Figure 6. Bandwidth Characterization, Frequency Response at $V_{CC}=3.3V$, $C_L=0pF$

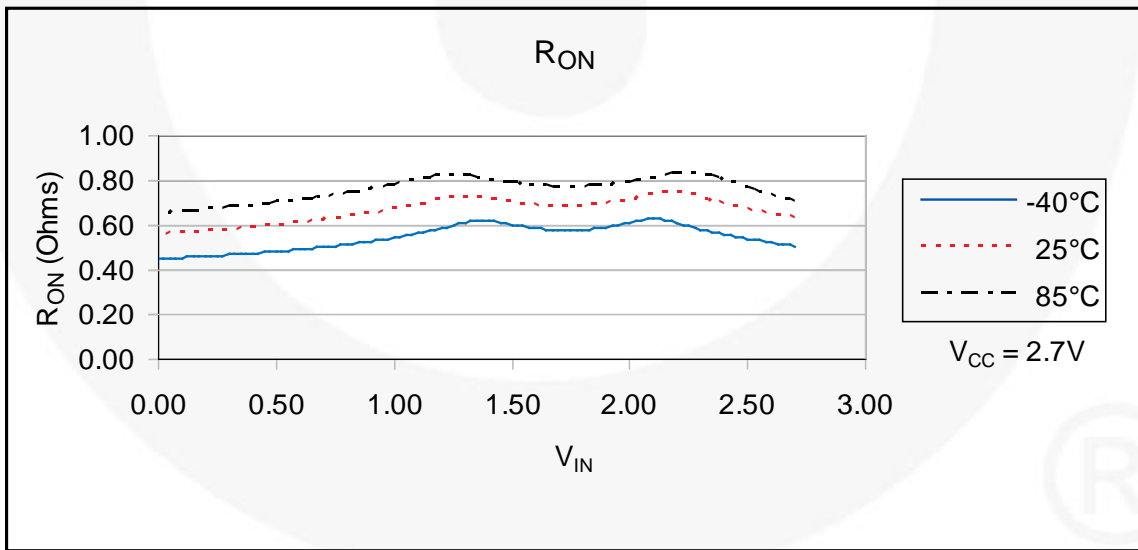
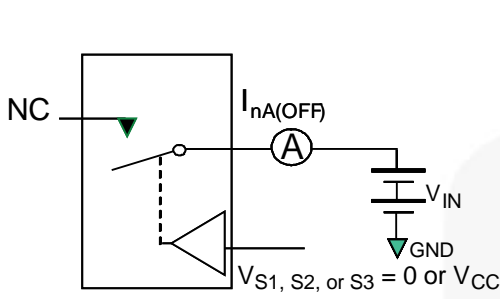

Figure 7. On Resistance

Test Diagrams



**Each switch port is tested separately

Figure 8. Off Leakage

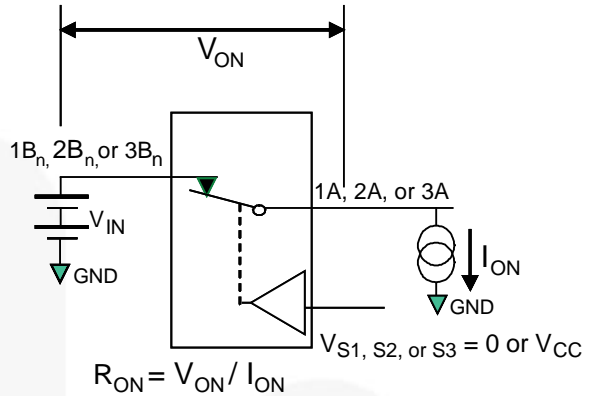
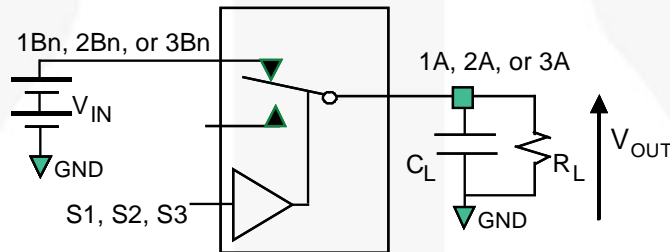
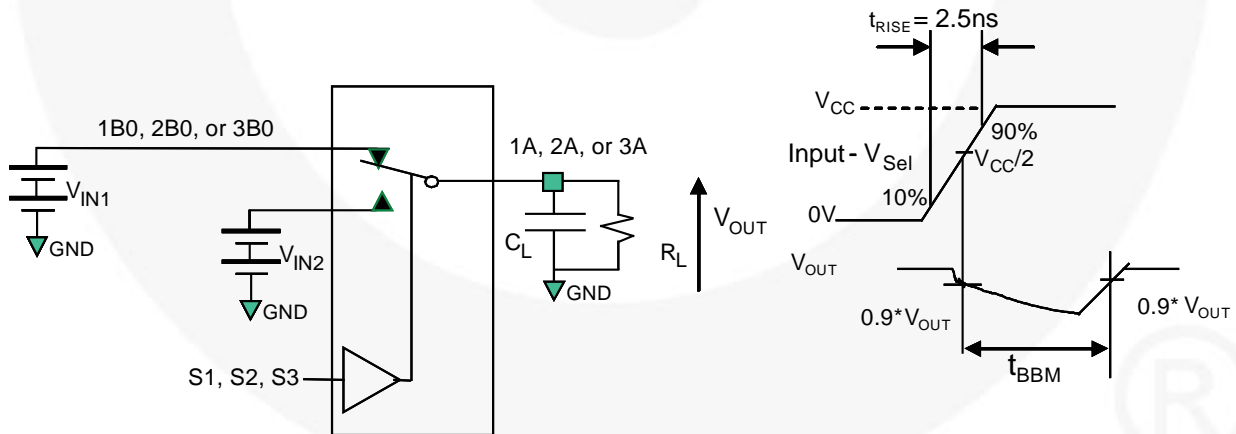

Figure 9. On Resistance



R_L and C_L are functions of the application environment (see AC Tables for specific values)
 C_L includes test fixture and stray capacitance

Figure 10. AC Test Circuit Load



R_L and C_L are functions of the application environment (see AC Tables for specific values)
 C_L includes test fixture and stray capacitance

Figure 11. Break-Before-Make Interval Timing

Test Diagrams (Continued)

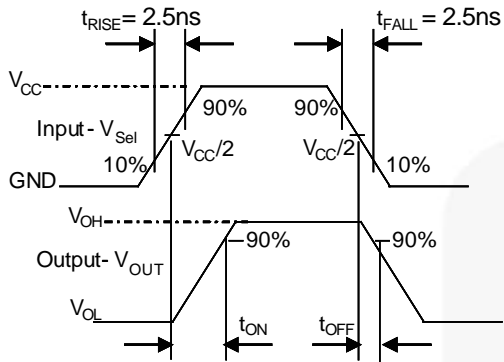

Figure 12. Turn-On / Turn-Off Waveforms

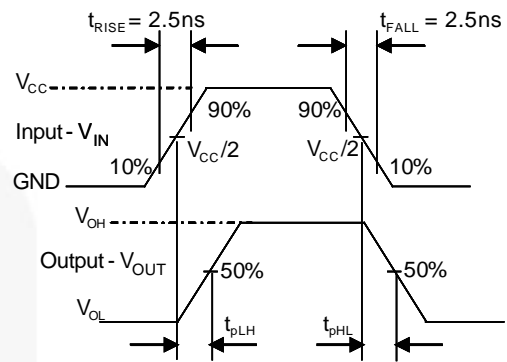

Figure 13. Switch Propagation Delay Waveforms

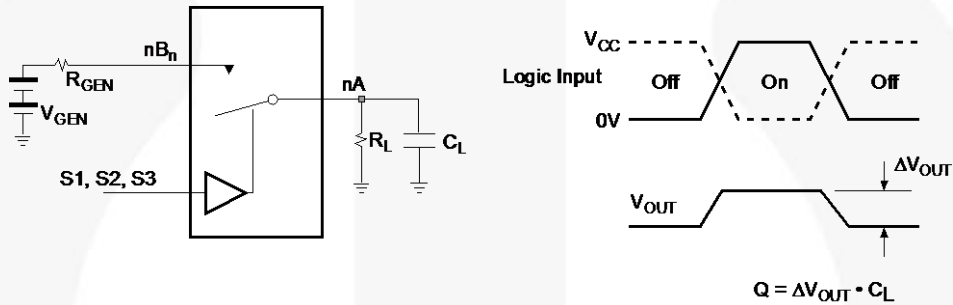
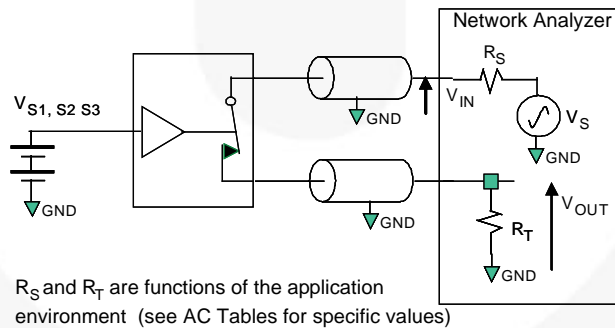
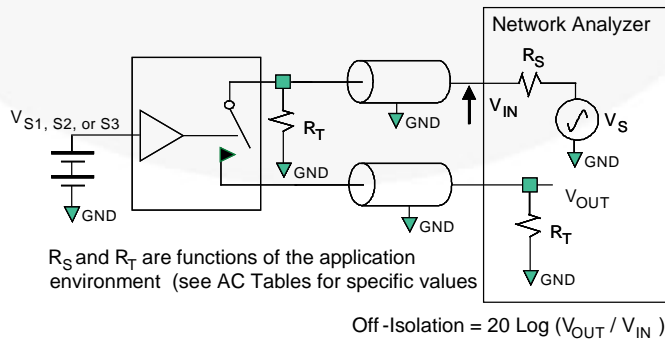

Figure 14. Charge Injection Test ($Q = \Delta V_{OUT} * C_L$)



R_S and R_T are functions of the application environment (see AC Tables for specific values)

Figure 15. Bandwidth



R_S and R_T are functions of the application environment (see AC Tables for specific values)

$$\text{Off-Isolation} = 20 \text{ Log} (V_{OUT} / V_{IN})$$

Figure 16. Channel Off Isolation

Test Diagrams (Continued)

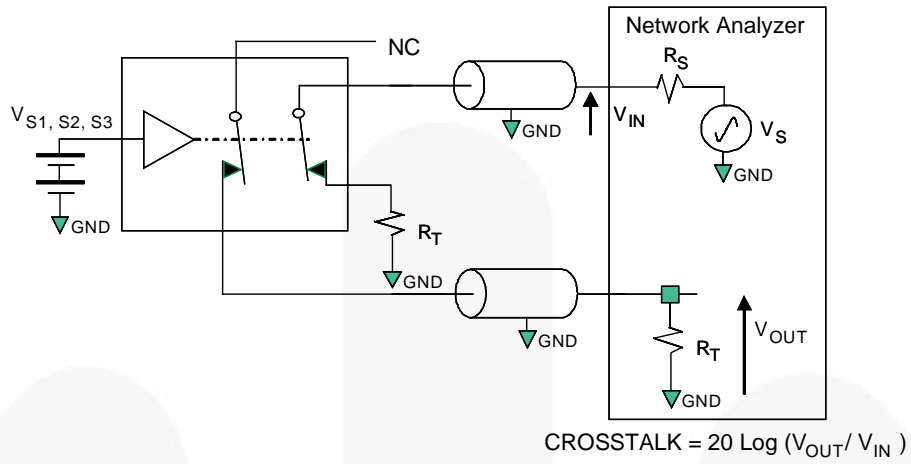

Figure 17. Non-Adjacent Channel-to-Channel Crosstalk

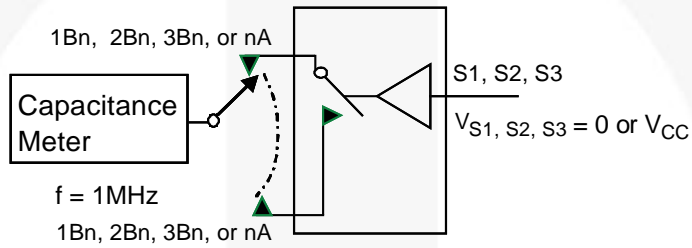

Figure 18. Channel Off Capacitance

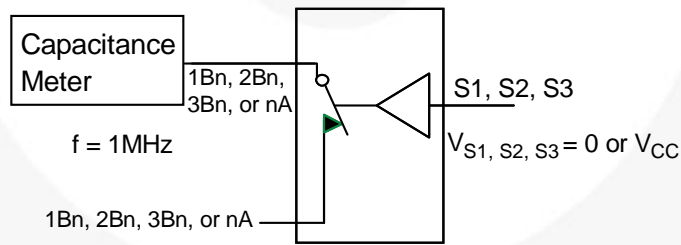

Figure 19. Channel On Capacitance

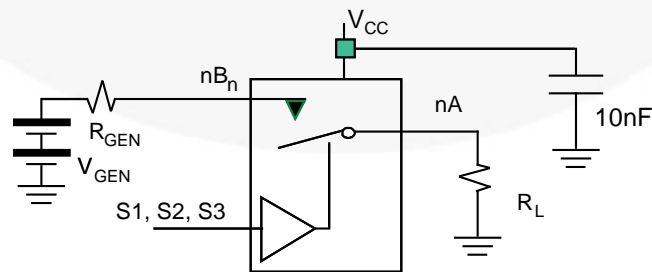
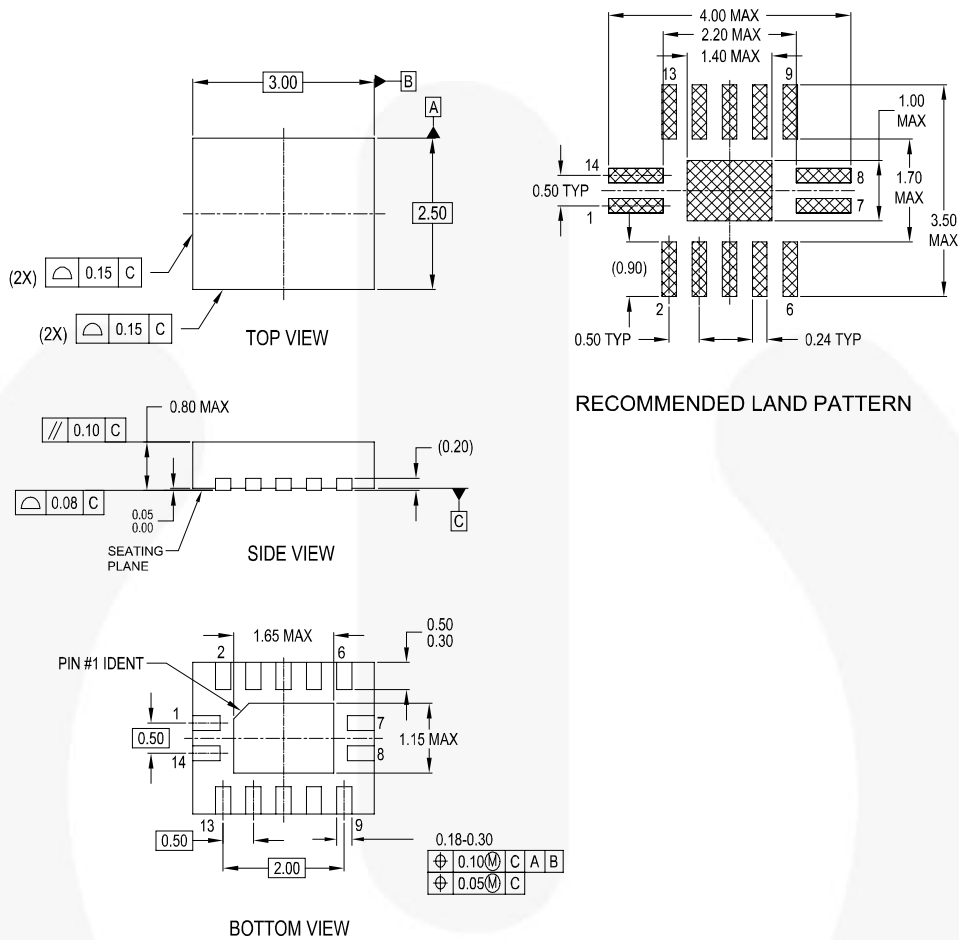

Figure 20. Total Harmonic Distortion

Physical Dimensions



NOTES:

- A. CONFORMS TO JEDEC REGISTRATION MO-241, VARIATION AA
- B. DIMENSIONS ARE IN MILLIMETERS
- C. DIMENSIONS AND TOLERANCES PER ASME Y14.5M, 1994

MLP14ArevA

Figure 21. 14-Terminal Depopulated very thin Quad Flat-pack No leads (DQFN)

Package drawings are provided as a service to customers considering Fairchild components. Drawings may change in any manner without notice. Please note the revision and/or date on the drawing and contact a Fairchild Semiconductor representative to verify or obtain the most recent revision. Package specifications do not expand the terms of Fairchild's worldwide terms and conditions, specifically the warranty therein, which covers Fairchild products.

Always visit Fairchild Semiconductor's online packaging area for the most recent package drawings:
<http://www.fairchildsemi.com/packaging/>

Physical Dimensions (Continued)

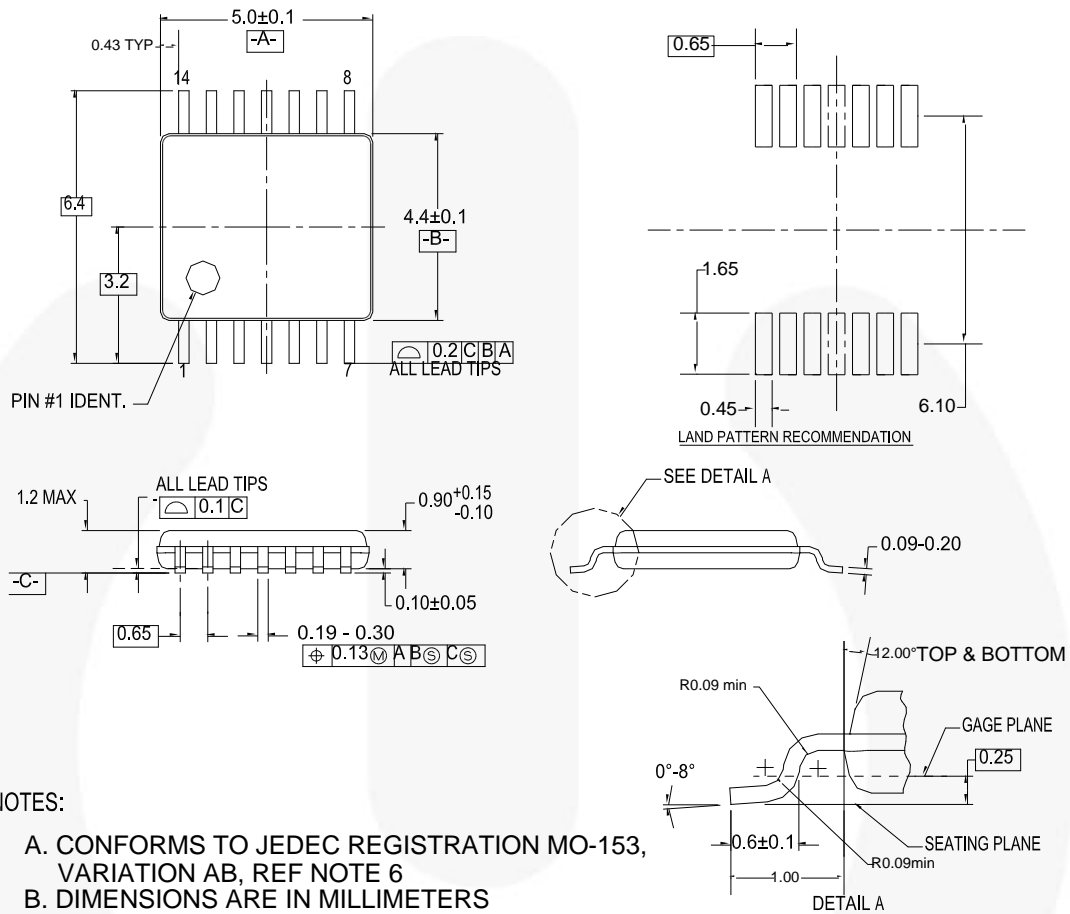

NOTES:

- A. CONFORMS TO JEDEC REGISTRATION MO-153, VARIATION AB, REF NOTE 6
- B. DIMENSIONS ARE IN MILLIMETERS
- C. DIMENSIONS ARE EXCLUSIVE OF BURRS, MOLD FLASH, AND TIE BAR EXTRUSIONS
- D. DIMENSIONING AND TOLERANCES PER ANSI Y14.5M, 1982
- E. LANDPATTERN STANDARD: SOP65P640X110-14M
- F. DRAWING FILE NAME: MTC14REV6

Figure 22. 4-Lead Thin Shrink Small Outline Package (TSSOP)







Package drawings are provided as a service to customers considering Fairchild components. Drawings may change in any manner without notice. Please note the revision and/or date on the drawing and contact a Fairchild Semiconductor representative to verify or obtain the most recent revision. Package specifications do not expand the terms of Fairchild's worldwide terms and conditions, specifically the warranty therein, which covers Fairchild products.

Always visit Fairchild Semiconductor's online packaging area for the most recent package drawings:
<http://www.fairchildsemi.com/packaging/>



TRADEMARKS

The following includes registered and unregistered trademarks and service marks, owned by Fairchild Semiconductor and/or its global subsidiaries, and is not intended to be an exhaustive list of all such trademarks.

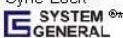
- | | | | |
|---|---|---|---|
| AccuPower™ | FPS™ | PowerTrench® | The Power Franchise® |
| Auto-SPM™ | F-PFS™ | PowerXS™ |  |
| Build it Now™ | FRFET® | Programmable Active Droop™ | TinyBoost™ |
| CorePLUS™ | Global Power Resource™ | QFET® | TinyBuck™ |
| CorePOWER™ | Green FPS™ | QST™ | TinyCalc™ |
| CROSSVOLT™ | Green FPS™ e-Series™ | Quiet Series™ | TinyLogic® |
| CTL™ | Gmax™ | RapidConfigure™ | TINYOPTO™ |
| Current Transfer Logic™ | GTOTM |  | TinyPower™ |
| EcoSPARK® | IntelliMAX™ | Saving our world, 1mW/W/kW at a time™ | TinyPWM™ |
| EfficientMax™ | ISOPLANAR™ | SignalWise™ | TinyWire™ |
| EZSWITCH™ | MegaBuck™ | SmartMax™ | TriFault Detect™ |
|  | MICROCOUPLER™ | SMART START™ | TRUECURRENT™ |
|  | MicroFET™ | SPM® | μSerDes™ |
| Fairchild® | MicroPak™ | STEALTH™ |  |
| Fairchild Semiconductor® | MillerDrive™ | SuperFET™ | UHC® |
| FACT Quiet Series™ | MotionMax™ | SuperSOT™-3 | Ultra FRFET™ |
| FACT® | Motion-SPM™ | SuperSOT™-6 | UniFET™ |
| FAST® | OPTOLOGIC® | SuperSOT™-8 | VCM™ |
| FastvCore™ | OPTOPLANAR® | SupreMOS™ | VisualMax™ |
| FETBench™ |  | SyncFET™ | XS™ |
| FlashWriter® | PDP SPM™ | Sync-Lock™ | |
| | Power-SPM™ |  | |

* Trademarks of System General Corporation, used under license by Fairchild Semiconductor.

DISCLAIMER

FAIRCHILD SEMICONDUCTOR RESERVES THE RIGHT TO MAKE CHANGES WITHOUT FURTHER NOTICE TO ANY PRODUCTS HEREIN TO IMPROVE RELIABILITY, FUNCTION, OR DESIGN. FAIRCHILD DOES NOT ASSUME ANY LIABILITY ARISING OUT OF THE APPLICATION OR USE OF ANY PRODUCT OR CIRCUIT DESCRIBED HEREIN; NEITHER DOES IT CONVEY ANY LICENSE UNDER ITS PATENT RIGHTS, NOR THE RIGHTS OF OTHERS. THESE SPECIFICATIONS DO NOT EXPAND THE TERMS OF FAIRCHILD'S WORLDWIDE TERMS AND CONDITIONS, SPECIFICALLY THE WARRANTY THEREIN, WHICH COVERS THESE PRODUCTS.

LIFE SUPPORT POLICY

FAIRCHILD'S PRODUCTS ARE NOT AUTHORIZED FOR USE AS CRITICAL COMPONENTS IN LIFE SUPPORT DEVICES OR SYSTEMS WITHOUT THE EXPRESS WRITTEN APPROVAL OF FAIRCHILD SEMICONDUCTOR CORPORATION.

As used herein:

1. Life support devices or systems are devices or systems which, (a) are intended for surgical implant into the body or (b) support or sustain life, and (c) whose failure to perform when properly used in accordance with instructions for use provided in the labeling, can be reasonably expected to result in a significant injury of the user.
2. A critical component in any component of a life support, device, or system whose failure to perform can be reasonably expected to cause the failure of the life support device or system, or to affect its safety or effectiveness.

ANTI-COUNTERFEITING POLICY

Fairchild Semiconductor Corporation's Anti-Counterfeiting Policy. Fairchild's Anti-Counterfeiting Policy is also stated on our external website, www.fairchildsemi.com, under Sales Support.

Counterfeiting of semiconductor parts is a growing problem in the industry. All manufacturers of semiconductor products are experiencing counterfeiting of their parts. Customers who inadvertently purchase counterfeit parts experience many problems such as loss of brand reputation, substandard performance, failed applications, and increased cost of production and manufacturing delays. Fairchild is taking strong measures to protect ourselves and our customers from the proliferation of counterfeit parts. Fairchild strongly encourages customers to purchase Fairchild parts either directly from Fairchild or from Authorized Fairchild Distributors who are listed by country on our web page cited above. Products customers buy either from Fairchild directly or from Authorized Fairchild Distributors are genuine parts, have full traceability, meet Fairchild's quality standards for handling and storage and provide access to Fairchild's full range of up-to-date technical and product information. Fairchild and our Authorized Distributors will stand behind all warranties and will appropriately address any warranty issues that may arise. Fairchild will not provide any warranty coverage or other assistance for parts bought from Unauthorized Sources. Fairchild is committed to combat this global problem and encourage our customers to do their part in stopping this practice by buying direct or from authorized distributors.

PRODUCT STATUS DEFINITIONS

Definition of Terms

Datasheet Identification	Product Status	Definition
Advance Information	Formative / In Design	Datasheet contains the design specifications for product development. Specifications may change in any manner without notice.
Preliminary	First Production	Datasheet contains preliminary data; supplementary data will be published at a later date. Fairchild Semiconductor reserves the right to make changes at any time without notice to improve design.
No Identification Needed	Full Production	Datasheet contains final specifications. Fairchild Semiconductor reserves the right to make changes at any time without notice to improve the design.
Obsolete	Not In Production	Datasheet contains specifications on a product that is discontinued by Fairchild Semiconductor. The datasheet is for reference information only.

Rev. I42

ON Semiconductor and  are trademarks of Semiconductor Components Industries, LLC dba ON Semiconductor or its subsidiaries in the United States and/or other countries. ON Semiconductor owns the rights to a number of patents, trademarks, copyrights, trade secrets, and other intellectual property. A listing of ON Semiconductor's product/patent coverage may be accessed at www.onsemi.com/site/pdf/Patent-Marking.pdf. ON Semiconductor reserves the right to make changes without further notice to any products herein. ON Semiconductor makes no warranty, representation or guarantee regarding the suitability of its products for any particular purpose, nor does ON Semiconductor assume any liability arising out of the application or use of any product or circuit, and specifically disclaims any and all liability, including without limitation special, consequential or incidental damages. Buyer is responsible for its products and applications using ON Semiconductor products, including compliance with all laws, regulations and safety requirements or standards, regardless of any support or applications information provided by ON Semiconductor. "Typical" parameters which may be provided in ON Semiconductor data sheets and/or specifications can and do vary in different applications and actual performance may vary over time. All operating parameters, including "Typicals" must be validated for each customer application by customer's technical experts. ON Semiconductor does not convey any license under its patent rights nor the rights of others. ON Semiconductor products are not designed, intended, or authorized for use as a critical component in life support systems or any FDA Class 3 medical devices or medical devices with a same or similar classification in a foreign jurisdiction or any devices intended for implantation in the human body. Should Buyer purchase or use ON Semiconductor products for any such unintended or unauthorized application, Buyer shall indemnify and hold ON Semiconductor and its officers, employees, subsidiaries, affiliates, and distributors harmless against all claims, costs, damages, and expenses, and reasonable attorney fees arising out of, directly or indirectly, any claim of personal injury or death associated with such unintended or unauthorized use, even if such claim alleges that ON Semiconductor was negligent regarding the design or manufacture of the part. ON Semiconductor is an Equal Opportunity/Affirmative Action Employer. This literature is subject to all applicable copyright laws and is not for resale in any manner.

PUBLICATION ORDERING INFORMATION

LITERATURE FULFILLMENT:

Literature Distribution Center for ON Semiconductor
19521 E. 32nd Pkwy, Aurora, Colorado 80011 USA
Phone: 303-675-2175 or 800-344-3860 Toll Free USA/Canada
Fax: 303-675-2176 or 800-344-3867 Toll Free USA/Canada
Email: orderlit@onsemi.com

N. American Technical Support: 800-282-9855 Toll Free
USA/Canada
Europe, Middle East and Africa Technical Support:
Phone: 421 33 790 2910
Japan Customer Focus Center
Phone: 81-3-5817-1050

ON Semiconductor Website: www.onsemi.com
Order Literature: <http://www.onsemi.com/orderlit>
For additional information, please contact your local
Sales Representative

Looking for pricing, stock, or lifecycle information?

Click below to explore more details on WIN SOURCE:

- ⊖ [View FSA2367BQX on WIN SOURCE](#)
- ⊖ [Fairchild/ON Semiconductor Information](#)

Optimize Your Supply Chain with WIN SOURCE Solutions

- ✓ Global Sourcing Solution
- ✓ Obsolete Management
- ✓ Cost Control Management
- ✓ Shortage Management
- ✓ Alternative Solution
- ✓ Excess Inventory Management