

3.3V, Hot Insertion, 8-Bit, 2-Port NanoSwitch

Features

- Near-Zero propagation delay
- 5-ohm switches connect inputs to outputs
- Fast Switching Speed: 4.5ns (max.)
- Ultra-Low Quiescent Power (0.2µA Typical)
 - Ideally suited for notebook applications
- Packaging (Pb-free & Green):
 - 20-pin 150-mil wide plastic QSOP (Q)
 - 20-pin 173-mil wide plastic TSSOP (L)

Description

Pericom Semiconductor’s PI3B series of logic circuits are produced using the Company’s advanced sub-micron CMOS technology, achieving industry leading performance.

The PI3B3244 features a set of 3.3V 8-bit bus switches, which is pinout and function compatible with the P74FCT244T, 74F244, and 74ALS/AS/LS2448-bit drivers. Two enable signals ($\overline{BE}n$) turn the switches on similar to the enable signals of the 244. The bus switch create no additional propagation delay or ground bounce noise.

Block Diagram

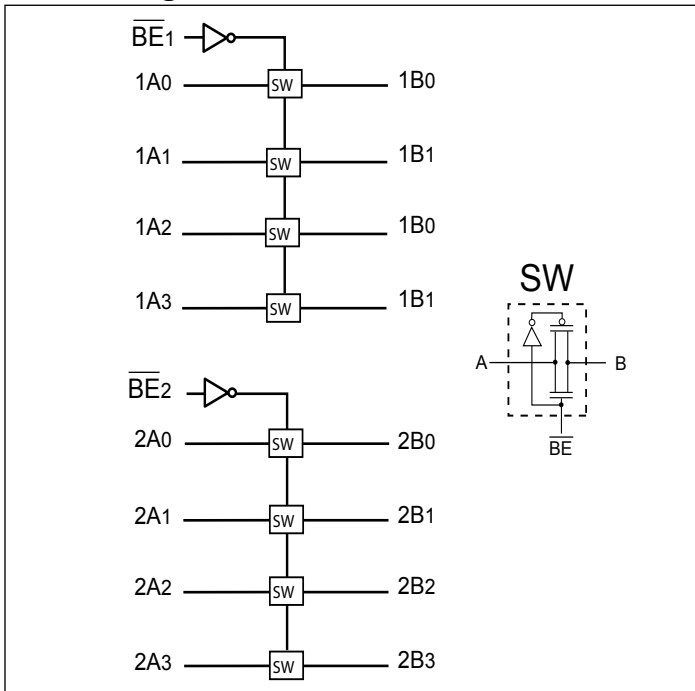

Pin Configuration

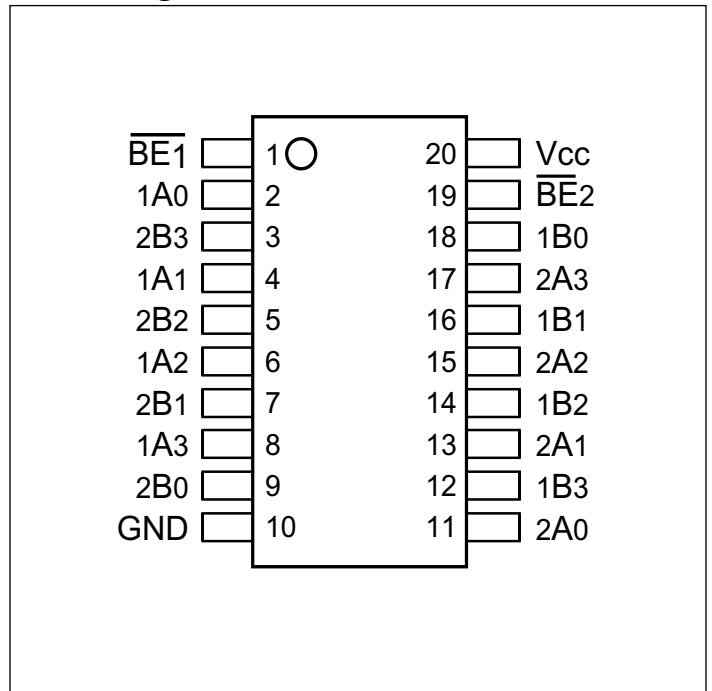

Pin Description

| Pin Name | Description |
|------------------|-------------------------------|
| $\overline{BE}n$ | Bus Enable Input (Active LOW) |
| A0-7 | Bus A |
| B0-7 | Bus B |
| GND | Ground |
| V _{CC} | Power |

Truth Table⁽¹⁾

| $\overline{BE}1$ | $\overline{BE}2$ | 1A, 1B | 2A, 2B |
|------------------|------------------|------------|------------|
| H | H | Disconnect | Disconnect |
| L | H | 1A = 1B | Disconnect |
| H | L | Disconnect | 2A = 2B |
| L | L | 1A = 1B | 2A = 2B |

Note:

1. H = High Voltage Level, L = Low Voltage Level

Maximum Ratings

(Above which useful life may be impaired. For user guidelines, not tested.)

| | |
|--|-----------------|
| Storage Temperature..... | -65°C to +150°C |
| Ambient Temperature with Power Applied | -40°C to +85°C |
| Supply Voltage to Ground Potential..... | -0.5V to +4.6V |
| DC Input Voltage | -0.5V to +4.6V |
| DC Output Current | 120mA |
| Power Dissipation | 0.5W |

Note:

Stresses greater than those listed under MAXIMUM RATINGS may cause permanent damage to the device. This is a stress rating only and functional operation of the device at these or any other conditions above those indicated in the operational sections of this specification is not implied. Exposure to absolute maximum rating conditions for extended periods may affect reliability.

DC Electrical Characteristics (Over the Operating Range, $T_A = -40^\circ\text{C}$ to $+85^\circ\text{C}$, $V_{CC} = 3.3\text{V} \pm 10\%$)

| Parameters | Description | Test Conditions ⁽¹⁾ | Min. | Typ. ⁽²⁾ | Max. | Units |
|------------|-------------------------------------|--|------|---------------------|---------|---------------|
| V_{IH} | Input HIGH Voltage | Guaranteed Logic HIGH Level | 2.0 | | | V |
| V_{IL} | Input LOW Voltage | Guaranteed Logic LOW Level | -0.5 | | 0.8 | V |
| I_{IH} | Input HIGH Current | $V_{CC} = \text{Max.}, V_{IN} = V_{CC}$ | | | ± 1 | μA |
| I_{IL} | Input LOW Current | $V_{CC} = \text{Max.}, V_{IN} = \text{GND}$ | | | ± 1 | μA |
| I_{OZH} | High Impedance Output Current | $0 \leq I_N, Y_N \leq V_{CC}$ | | | ± 1 | μA |
| V_{IK} | Clamp Diode Voltage | $V_{CC} = \text{Min.}, I_{IN} = -18 \text{ mA}$ | | | -1.2 | V |
| R_{ON} | Switch On Resistance ⁽³⁾ | $V_{CC} = \text{Min.}, V_{IN} = 0.0\text{V}, I_{ON} = 48\text{mA}$ or 64mA | | 5 | 8 | Ω |
| | | $V_{CC} = \text{Min.}, V_{IN} = 2.4\text{V}, I_{ON} = 15\text{mA}$ | | 10 | 17 | |

Capacitance ($T_A = 25^\circ\text{C}$, $f = 1 \text{ MHz}$)

| Parameters ⁽¹⁾ | Description | Test Conditions | Typ. | Units |
|---------------------------|-----------------------------|----------------------|------|-------|
| C_{IN} | Input Capacitance | $V_{IN} = 0\text{V}$ | 3.0 | pF |
| C_{OFF} | A/B Capacitance, Switch Off | $V_{IN} = 0\text{V}$ | 8.0 | pF |
| C_{ON} | A/B Capacitance, Switch On | $V_{IN} = 0\text{V}$ | 16.0 | pF |

Notes:

1. For Max. or Min. conditions, use appropriate value specified under Electrical Characteristics for the applicable device type.
2. Typical values are at $V_{CC} = 3.3\text{V}$, $T_A = 25^\circ\text{C}$ ambient and maximum loading.
3. Measured by the voltage drop between A and B pin at indicated current through the switch. ON resistance is determined by the lower of the voltages on the two (A,B) pins.
4. This parameter is determined by device characterization but is not production tested.

Power Supply Characteristics

| Parameters | Description | Test Conditions ⁽¹⁾ | | Min. | Typ. ⁽²⁾ | Max. | Units |
|-----------------|-------------------------------------|--------------------------------|----------------------------------|------|---------------------|------|---------------|
| I_{CC} | Quiescent Power Supply Current | $V_{CC} = \text{Max.}$ | $V_{IN} = \text{GND or } V_{CC}$ | | 0.1 | 3.0 | μA |
| ΔI_{CC} | Supply Current per Input @ TTL HIGH | $V_{CC} = \text{Max.}$ | $V_{IN} = 3.0\text{V}^{(3)}$ | | | 750 | μA |

Notes:

- For Max. or Min. conditions, use appropriate value specified under Electrical Characteristics for the applicable device.
- Typical values are at $V_{CC} = 3.3\text{V}$, $+25^\circ\text{C}$ ambient.
- Per TTL driven input (control input only); A and B pins do not contribute to I_{CC} .

Switching Characteristics over Operating Range

| Parameters | Description | Test Conditions ⁽¹⁾ | Com. | | Units |
|------------------------|--|---------------------------------|------|------|-------|
| | | | Min. | Max. | |
| t_{PLH} t_{PHL} | Propagation Delay ^(2,3) Ax to Bx | CL = 50 pF RL = 500 Ω | | 0.25 | ns |
| t_{PZH} t_{PZL} | Bus Enable Time $\overline{\text{BE}}$ to Ax or Bx | | 1.0 | 4.0 | |
| t_{PHZ} t_{PLZ} | Bus Disable Time $\overline{\text{BE}}$ to Ax or Bx | | 1.0 | 4.5 | |

Notes:

- See test circuit and wave forms.
- This parameter is guaranteed but not tested on Propagation Delays.
- The bus switch contributes no propagational delay other than the RC delay of the On-Resistance of the switch and the load capacitance. The time constant for the switch alone is of the order of 0.25 ns for 50 pF load. Since this time constant is much smaller than the rise/fall times of typical driving signals, it adds very little propagational delay to the system. Propagational delay of the bus switch when used in a system is determined by the driving circuit on the driving side of the switch and its interaction with the load on the driven side.

Applications Information

Logic Inputs

The logic control inputs can be driven up to +3.6V regardless of the supply voltage. For example, given a + 3.3V supply, IN may be driven low to 0V and high to 3.6V. Driving IN Rail-to-Rail® minimizes power consumption.

Power-Supply Sequencing and Hot-Plug Information

Proper power-supply sequencing is recommended for all CMOS devices. Always apply V_{CC} and GND before applying signals to input/output or control pins.

Rail-to-Rail is a registered trademark of Nippon Motorola, Ltd.

PI3B3244

Packaging Mechanical: 20-Pin QSOP (Q)

| SYMBOLS | MIN. | NOM. | MAX. |
|---------|-----------|-------|--------|
| A | — | — | 0.069 |
| A1 | 0.004 | — | 0.0098 |
| A2 | 0.049 | — | — |
| b | 0.008 | — | 0.012 |
| c | 0.004 | — | 0.010 |
| D | 0.337 | 0.341 | 0.345 |
| E | 0.228 | 0.236 | 0.244 |
| E1 | 0.150 | 0.154 | 0.158 |
| e | 0.025 BSC | | |
| L | 0.016 | 0.025 | 0.050 |
| L1 | 0.041 REF | | |
| θ° | 0° | — | 8° |

UNIT : INCH

SEATING PLANE

GAUGE PLANE
SEATING PLANE

DETAIL A

DATE: 03/24/16

PERICOM
Enabling Serial Connectivity

DESCRIPTION: 20-Pin, 150mil Wide QSOP

PACKAGE CODE: Q (Q20)

DOCUMENT CONTROL #: PD-1202

REVISION: I

NOTES:
1. ALL DIMENSIONS IN INCH. ANGLES IN DEGREES.
2. JEDEC MO-137E
3. DIMENSIONS DOES NOT INCLUDE MOLD FLASH, PROTRUSIONS OR GATE BURRS.

16-0057

Packaging Mechanical: 20-Pin TSSOP (L)

| SYMBOLS | MIN. | NOM. | MAX. |
|----------|----------|------|------|
| A | — | — | 1.20 |
| A1 | 0.05 | — | 0.15 |
| A2 | 0.80 | 1.00 | 1.05 |
| b | 0.19 | — | 0.30 |
| C | 0.09 | — | 0.20 |
| D | 6.40 | 6.50 | 6.60 |
| E1 | 4.30 | 4.40 | 4.50 |
| E | 6.20 | 6.40 | 6.60 |
| e | 0.65 BSC | | |
| L1 | 1.00 REF | | |
| L | 0.45 | 0.60 | 0.75 |
| S | 0.20 | — | — |
| θ | 0° | — | 8° |

NOTES:
 1. ALL DIMENSIONS IN MILLIMETERS. ANGLES IN DEGREES.
 2. JEDEC MO-153F
 3. DIMENSIONS DOES NOT INCLUDE MOLD FLASH, PROTRUSIONS OR GATE BURRS.

PERICOM
Enabling Serial Connectivity

DATE: 03/31/16

DESCRIPTION: 20-Pin, 173mil Wide TSSOP

PACKAGE CODE: L (L20)

DOCUMENT CONTROL #: PD-1311

REVISION: G

16-0074

Note: For latest package info, please check: <http://www.pericom.com/support/packaging/packaging-mechanicals-and-thermal-characteristics/>

Ordering Information

| Ordering Code | Package Code | Package Type |
|---------------|--------------|--|
| PI3B3244QE | Q | 20-Pin, 150mil Wide (QSOP) |
| PI3B3244QEX | Q | 20-Pin, 150mil Wide (QSOP), Tape & Reel |
| PI3B3244LE | L | 20-Pin, 173mil Wide (TSSOP) |
| PI3B3244LEX | L | 20-Pin, 173mil Wide (TSSOP), Tape & Reel |



1. Thermal characteristics can be found on the company web site at www.pericom.com/packaging/

2. E = Lead-free and Green

3. Adding X suffix = Tape/Reel

Looking for pricing, stock, or lifecycle information?

Click below to explore more details on WIN SOURCE:

-  [View PI3B3244LE on WIN SOURCE](#)
-  [Diodes Incorporated Information](#)

Optimize Your Supply Chain with WIN SOURCE Solutions

-  Global Sourcing Solution
-  Obsolete Management
-  Cost Control Management
-  Shortage Management
-  Alternative Solution
-  Excess Inventory Management