



**THE DATASHEET OF
ADSP-21369KBPZ-3A**



SUMMARY

High performance 32-bit/40-bit floating-point processor optimized for high performance audio processing
 Single-instruction, multiple-data (SIMD) computational architecture
 On-chip memory—2M bits of on-chip SRAM and 6M bits of on-chip mask programmable ROM
 Code compatible with all other members of the SHARC family
 400 MHz core instruction rate with unique audiocentric peripherals such as the digital applications interface, S/PDIF transceiver, serial ports, 8-channel asynchronous sample rate converter, precision clock generators, and more. For complete ordering information, see [Ordering Guide](#).

DEDICATED AUDIO COMPONENTS

S/PDIF-compatible digital audio receiver/transmitter
 4 independent asynchronous sample rate converters (SRC)
 16 PWM outputs configured as four groups of four outputs
 ROM-based security features include
 JTAG access to memory permitted with a 64-bit key
 Protected memory regions that can be assigned to limit access under program control to sensitive code
 PLL has a wide variety of software and hardware multiplier/divider ratios
 Available in 256-ball BGA_ED and 208-lead LQFP_EP packages

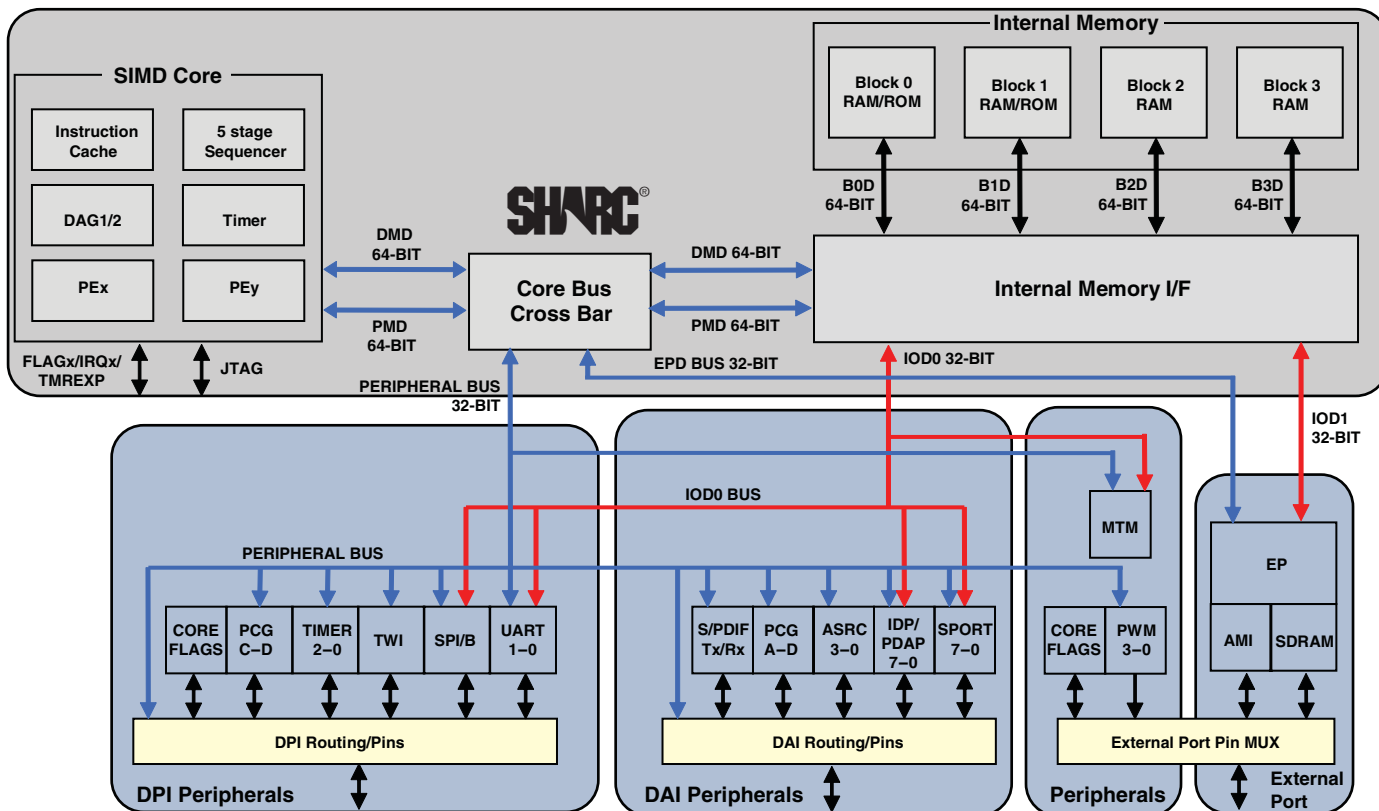

Figure 1. Functional Block Diagram

SHARC and the SHARC logo are registered trademarks of Analog Devices, Inc.

Rev. H

[Document Feedback](#)

Information furnished by Analog Devices is believed to be accurate and reliable. However, no responsibility is assumed by Analog Devices for its use, nor for any infringements of patents or other rights of third parties that may result from its use. Specifications subject to change without notice. No license is granted by implication or otherwise under any patent or patent rights of Analog Devices. Trademarks and registered trademarks are the property of their respective companies.

TABLE OF CONTENTS

General Description	3	Maximum Power Dissipation	17
SHARC Family Core Architecture	4	Absolute Maximum Ratings	18
Family Peripheral Architecture	7	Timing Specifications	18
I/O Processor Features	10	Output Drive Currents	50
System Design	10	Test Conditions	50
Development Tools	11	Capacitive Loading	50
Additional Information	12	Thermal Characteristics	52
Related Signal Chains	12	256-Ball BGA_ED Pinout	53
Pin Function Descriptions	13	208-Lead LQFP_EP Pinout	56
Specifications	16	Package Dimensions	58
Operating Conditions	16	Surface-Mount Design	59
Electrical Characteristics	17	Ordering Guide	60
ESD Caution	17		

REVISION HISTORY

3/2019—Rev. G to Rev. H

Deleted obsolete models ADSP-21367 and ADSP-21368 throughout data sheet.

Reorganized layout of data sheet.

GENERAL DESCRIPTION

The ADSP-21369 SHARC[®] processor is a member of the SIMD SHARC family of DSPs that feature Analog Devices' Super Harvard Architecture. These processors are source code-compatible with the ADSP-2126x and ADSP-2116x DSPs as well as with first generation ADSP-2106x SHARC processors in SISD (single-instruction, single-data) mode. The processors are 32-bit/40-bit floating-point processors optimized for high performance automotive audio applications with its large on-chip SRAM, mask programmable ROM, multiple internal buses to eliminate I/O bottlenecks, and an innovative digital applications interface (DAI).

As shown in the functional block diagram on Page 1, the processor uses two computational units to deliver a significant performance increase over the previous SHARC processors on a range of DSP algorithms. Fabricated in a state-of-the-art, high speed, CMOS process, the processor achieves an instruction cycle time of up to 2.5 ns at 400 MHz. With its SIMD computational hardware, the processor can perform 2.4 GFLOPS running at 400 MHz.

Table 1 shows performance benchmarks for the ADSP-21369 processor.

Table 1. Processor Benchmarks (at 400 MHz)

Benchmark Algorithm	Speed (at 400 MHz)
1024 Point Complex FFT (Radix 4, with Reversal)	23.2 μs
FIR Filter (per Tap) ¹	1.25 ns
IIR Filter (per Biquad) ¹	5.0 ns
Matrix Multiply (Pipelined)	
[3×3] × [3×1]	11.25 ns
[4×4] × [4×1]	20.0 ns
Divide (y/x)	8.75 ns
Inverse Square Root	13.5 ns

¹ Assumes two files in multichannel SIMD mode.

Table 2. Product Features

Feature	ADSP-21369
Frequency	400 MHz
RAM	2M bits
ROM	6M bits
Pulse-Width Modulation	Yes
S/PDIF	Yes
SDRAM Memory Bus Width	32 bits/16 bits
Serial Ports	8
IDP	Yes
DAI	Yes
UART	2

Table 2. Product Features (Continued)

Feature	ADSP-21369
DPI	Yes
S/PDIF Transceiver	1
AMI Interface Bus Width	32 bits/16 bits/8 bits
SPI	2
TWI	Yes
SRC Performance	128 dB
Shared Memory Support	256-Ball BGA only
Package	256-Ball BGA, 208-Lead LQFP_EP

The diagram on Page 1 shows the two clock domains. The core clock domain contains the following features.

- Two processing elements (PE_x, PE_y), each of which comprises an ALU, multiplier, shifter, and data register file
- Data address generators (DAG1, DAG2)
- Program sequencer with instruction cache
- PM and DM buses capable of supporting two 64-bit data transfers between memory and the core at every core processor cycle
- One periodic interval timer with pinout
- On-chip SRAM (2M bit)
- JTAG test access port for emulation and boundary scan. The JTAG provides software debug through user breakpoints which allows flexible exception handling.

The block diagram on Page 1 also shows the peripheral clock domain (also known as the I/O processor) and contains the following features:

- IOD0 (peripheral DMA) and IOD1 (external port DMA) buses for 32-bit data transfers
- Peripheral and external port buses for core connection
- External port with an AMI and SDRAM controller
- 4 units for PWM control
- 1 MTM unit for internal-to-internal memory transfers
- Digital applications interface that includes four precision clock generators (PCG), a input data port (IDP) for serial and parallel interconnect, an S/PDIF receiver/transmitter, four asynchronous sample rate converters, eight serial ports, a flexible signal routing unit (DAI SRU).
- Digital peripheral interface that includes three timers, a 2-wire interface, two UARTs, two serial peripheral interfaces (SPI), 2 precision clock generators (PCG) and a flexible signal routing unit (DPI SRU).

ADSP-21369

SHARC FAMILY CORE ARCHITECTURE

The processor is code compatible at the assembly level with the ADSP-2126x, ADSP-21160, and ADSP-21161, and with the first generation ADSP-2106x SHARC processors. The processor

shares architectural features with the ADSP-2126x and ADSP-2116x SIMD SHARC processors, as shown in [Figure 2](#) and detailed in the following sections.

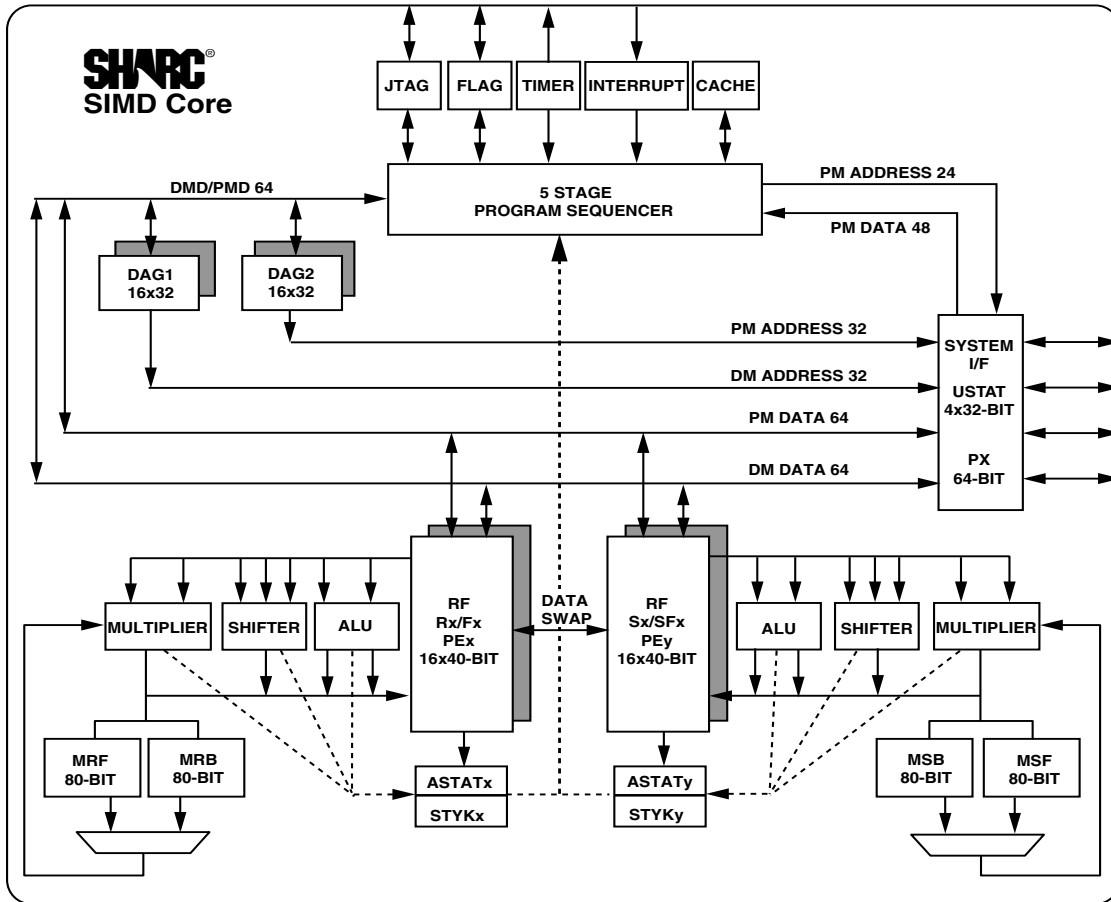

Figure 2. SHARC Core Block Diagram

SIMD Computational Engine

The processor contains two computational processing elements that operate as a single-instruction, multiple-data (SIMD) engine. The processing elements are referred to as PEX and PEY and each contains an ALU, multiplier, shifter, and register file. PEX is always active, and PEY may be enabled by setting the PEYEN mode bit in the MODE1 register. When this mode is enabled, the same instruction is executed in both processing elements, but each processing element operates on different data. This architecture is efficient at executing math intensive DSP algorithms.

Entering SIMD mode also has an effect on the way data is transferred between memory and the processing elements. When in SIMD mode, twice the data bandwidth is required to sustain computational operation in the processing elements. Because of this requirement, entering SIMD mode also doubles the bandwidth between memory and the processing elements. When using the DAGs to transfer data in SIMD mode, two data values are transferred with each access of memory or the register file.

Independent, Parallel Computation Units

Within each processing element is a set of computational units. The computational units consist of an arithmetic/logic unit (ALU), multiplier, and shifter. These units perform all operations in a single cycle. The three units within each processing element are arranged in parallel, maximizing computational throughput. Single multifunction instructions execute parallel ALU and multiplier operations. In SIMD mode, the parallel ALU and multiplier operations occur in both processing elements. These computation units support IEEE 32-bit single-precision floating-point, 40-bit extended precision floating-point, and 32-bit fixed-point data formats.

Data Register File

A general-purpose data register file is contained in each processing element. The register files transfer data between the computation units and the data buses, and store intermediate results. These 10-port, 32-register (16 primary, 16 secondary) register files, combined with the enhanced Harvard architecture of the ADSP-21369 processor, allow unconstrained data flow between computation units and internal memory. The registers in PEX are referred to as R0–R15 and in PEY as S0–S15.

Context Switch

Many of the processor's registers have secondary registers that can be activated during interrupt servicing for a fast context switch. The data registers in the register file, the DAG registers, and the multiplier result registers all have secondary registers. The primary registers are active at reset, while the secondary registers are activated by control bits in a mode control register.

Universal Registers

These registers can be used for general-purpose tasks. The USTAT (4) registers allow easy bit manipulations (Set, Clear, Toggle, Test, XOR) for all system registers (control/status) of the core.

The data bus exchange register (PX) permits data to be passed between the 64-bit PM data bus and the 64-bit DM data bus, or between the 40-bit register file and the PM data bus. These registers contain hardware to handle the data width difference.

Timer

A core timer that can generate periodic software Interrupts. The core timer can be configured to use FLAG3 as a timer expired signal.

Single-Cycle Fetch of Instruction and Four Operands

The processor features an enhanced Harvard architecture in which the data memory (DM) bus transfers data and the program memory (PM) bus transfers both instructions and data (see Figure 2). With separate program and data memory buses and on-chip instruction cache, the processors can simultaneously fetch four operands (two over each data bus) and one instruction (from the cache), all in a single cycle.

Instruction Cache

The processors include an on-chip instruction cache that enables three-bus operation for fetching an instruction and four data values. The cache is selective—only the instructions whose fetches conflict with PM bus data accesses are cached. This cache allows full-speed execution of core, looped operations such as digital filter multiply-accumulates, and FFT butterfly processing.

Data Address Generators with Zero-Overhead Hardware Circular Buffer Support

The processor has two data address generators (DAGs). The DAGs are used for indirect addressing and implementing circular data buffers in hardware. Circular buffers allow efficient programming of delay lines and other data structures required in digital signal processing, and are commonly used in digital filters and Fourier transforms. The two DAGs contain sufficient registers to allow the creation of up to 32 circular buffers (16 primary register sets, 16 secondary). The DAGs automatically handle address pointer wraparound, reduce overhead, increase performance, and simplify implementation. Circular buffers can start and end at any memory location.

Flexible Instruction Set

The 48-bit instruction word accommodates a variety of parallel operations for concise programming. For example, the ADSP-21369 processor can conditionally execute a multiply, an add, and a subtract in both processing elements while branching and fetching up to four 32-bit values from memory—all in a single instruction.

On-Chip Memory

The processors contain two megabits of internal RAM and six megabits of internal mask-programmable ROM. Each block can be configured for different combinations of code and data storage (see Table 3). Each memory block supports single-cycle, independent accesses by the core processor and I/O processor. The memory architecture, in combination with its separate on-chip buses, allows two data transfers from the core and one from the I/O processor, in a single cycle.

The SRAM can be configured as a maximum of 64k words of 32-bit data, 128k words of 16-bit data, 42k words of 48-bit instructions (or 40-bit data), or combinations of different word sizes up to two megabits. All of the memory can be accessed as 16-bit, 32-bit, 48-bit, or 64-bit words. A 16-bit floating-point storage format is supported that effectively doubles the amount of data that can be stored on-chip. Conversion between the 32-bit floating-point and 16-bit floating-point formats is performed in a single instruction. While each memory block can store combinations of code and data, accesses are most efficient when one block stores data using the DM bus for transfers, and the other block stores instructions and data using the PM bus for transfers.

Using the DM bus and PM buses, with one bus dedicated to each memory block, assures single-cycle execution with two data transfers. In this case, the instruction must be available in the cache.

On-Chip Memory Bandwidth

The internal memory architecture allows programs to have four accesses at the same time to any of the four blocks (assuming there are no block conflicts). The total bandwidth is realized using the DMD and PMD buses (2 × 64-bit, core CLK) and the IOD0/1 buses (2 × 32-bit, PCLK).

ROM-Based Security

The processor has a ROM security feature that provides hardware support for securing user software code by preventing unauthorized reading from the internal code when enabled. When using this feature, the processor does not boot-load any external code, executing exclusively from internal ROM. Additionally, the processor is not freely accessible via the JTAG port. Instead, a unique 64-bit key, which must be scanned in through the JTAG or test access port will be assigned to each customer. The device will ignore a wrong key. Emulation features and external boot modes are only available after the correct key is scanned.

Table 3. Internal Memory Space ¹

IOP Registers 0x0000 0000–0x0003 FFFF			
Long Word (64 Bits)	Extended Precision Normal or Instruction Word (48 Bits)	Normal Word (32 Bits)	Short Word (16 Bits)
Block 0 ROM (Reserved) 0x0004 0000–0x0004 BFFF	Block 0 ROM (Reserved) 0x0008 0000–0x0008 FFFF	Block 0 ROM (Reserved) 0x0008 0000–0x0009 7FFF	Block 0 ROM (Reserved) 0x0010 0000–0x0012 FFFF
Reserved 0x0004 F000–0x0004 FFFF	Reserved 0x0009 4000–0x0009 FFFF	Reserved 0x0009 E000–0x0009 FFFF	Reserved 0x0013 C000–0x0013 FFFF
Block 0 SRAM 0x0004 C000–0x0004 EFFF	Block 0 SRAM 0x0009 0000–0x0009 3FFF	Block 0 SRAM 0x0009 8000–0x0009 DFFF	Block 0 SRAM 0x0013 0000–0x0013 BFFF
Block 1 ROM (Reserved) 0x0005 0000–0x0005 BFFF	Block 1 ROM (Reserved) 0x000A 0000–0x000A FFFF	Block 1 ROM (Reserved) 0x000A 0000–0x000B 7FFF	Block 1 ROM (Reserved) 0x0014 0000–0x0016 FFFF
Reserved 0x0005 F000–0x0005 FFFF	Reserved 0x000B 4000–0x000B FFFF	Reserved 0x000B E000–0x000B FFFF	Reserved 0x0017 C000–0x0017 FFFF
Block 1 SRAM 0x0005 C000–0x0005 EFFF	Block 1 SRAM 0x000B 0000–0x000B 3FFF	Block 1 SRAM 0x000B 8000–0x000B DFFF	Block 1 SRAM 0x0017 0000–0x0017 BFFF
Block 2 SRAM 0x0006 0000–0x0006 0FFF	Block 2 SRAM 0x000C 0000–0x000C 1554	Block 2 SRAM 0x000C 0000–0x000C 1FFF	Block 2 SRAM 0x0018 0000–0x0018 3FFF
Reserved 0x0006 1000–0x0006 FFFF	Reserved 0x000C 1555–0x000C 3FFF	Reserved 0x000C 2000–0x000D FFFF	Reserved 0x0018 4000–0x001B FFFF
Block 3 SRAM 0x0007 0000–0x0007 0FFF	Block 3 SRAM 0x000E 0000–0x000E 1554	Block 3 SRAM 0x000E 0000–0x000E 1FFF	Block 3 SRAM 0x001C 0000–0x001C 3FFF
Reserved 0x0007 1000–0x0007 FFFF	Reserved 0x000E 1555–0x000F FFFF	Reserved 0x000E 2000–0x000F FFFF	Reserved 0x001C 4000–0x001F FFFF

¹ The processor includes a customer-definable ROM block. Please contact your Analog Devices sales representative for additional details.

FAMILY PERIPHERAL ARCHITECTURE

The processor contains a rich set of peripherals that support a wide variety of applications including high quality audio, medical imaging, communications, military, test equipment, 3D graphics, speech recognition, motor control, imaging, and other applications.

External Port

The external port interface supports access to the external memory through core and DMA accesses. The external memory address space is divided into four banks. Any bank can be programmed as either asynchronous or synchronous memory. The external ports of the processor are comprised of the following modules.

- An Asynchronous Memory Interface which communicates with SRAM, FLASH, and other devices that meet the standard asynchronous SRAM access protocol. The AMI supports 14M words of external memory in bank 0 and 16M words of external memory in bank 1, bank 2, and bank 3.
- An SDRAM controller that supports a glueless interface with any of the standard SDRAMs. The SDC supports 62M words of external memory in bank 0, and 64M words of external memory in bank 1, bank 2, and bank 3.
- Arbitration Logic to coordinate core and DMA transfers between internal and external memory over the external port.
- A Shared Memory Interface that allows the connection of up to four processors to create shared external bus systems.

SDRAM Controller

The SDRAM controller provides an interface of up to four separate banks of industry-standard SDRAM devices or DIMMs, at speeds up to f_{CLK} . Fully compliant with the SDRAM standard, each bank has its own memory select line ($\overline{MS0}$ – $\overline{MS3}$), and can be configured to contain between 16M bytes and 128M bytes of memory. SDRAM external memory address space is shown in [Table 4](#).

A set of programmable timing parameters is available to configure the SDRAM banks to support slower memory devices. The memory banks can be configured as either 32 bits wide for maximum performance and bandwidth or 16 bits wide for minimum device count and lower system cost.

The SDRAM controller address, data, clock, and control pins can drive loads up to distributed 30 pF loads. For larger memory systems, the SDRAM controller external buffer timing should be selected and external buffering should be provided so that the load on the SDRAM controller pins does not exceed 30 pF.

External Memory

The external port provides a high performance, glueless interface to a wide variety of industry-standard memory devices. The 32-bit wide bus can be used to interface to synchronous and/or asynchronous memory devices through the use of its separate internal memory controllers. The first is an SDRAM controller for connection of industry-standard synchronous DRAM

Table 4. External Memory for SDRAM Addresses

Bank	Size in Words	Address Range
Bank 0	62M	0x0020 0000–0x03FF FFFF
Bank 1	64M	0x0400 0000–0x07FF FFFF
Bank 2	64M	0x0800 0000–0x0BFF FFFF
Bank 3	64M	0x0C00 0000–0x0FFF FFFF

devices and DIMMs (dual inline memory module), while the second is an asynchronous memory controller intended to interface to a variety of memory devices. Four memory select pins enable up to four separate devices to coexist, supporting any desired combination of synchronous and asynchronous device types. Non-SDRAM external memory address space is shown in [Table 5](#).

Table 5. External Memory for Non-SDRAM Addresses

Bank	Size in Words	Address Range
Bank 0	14M	0x0020 0000–0x00FF FFFF
Bank 1	16M	0x0400 0000–0x04FF FFFF
Bank 2	16M	0x0800 0000–0x08FF FFFF
Bank 3	16M	0x0C00 0000–0x0CFF FFFF

Shared External Memory

The ADSP-21369 processor supports connecting to common shared external memory with other ADSP-21369 processors to create shared external bus processor systems. This support includes:

- Distributed, on-chip arbitration for the shared external bus
- Fixed and rotating priority bus arbitration
- Bus time-out logic
- Bus lock

Multiple processors can share the external bus with no additional arbitration logic. Arbitration logic is included on-chip to allow the connection of up to four processors.

Bus arbitration is accomplished through the $\overline{BR1}$ –4 signals and the priority scheme for bus arbitration is determined by the setting of the RPBA pin. [Table 8](#) provides descriptions of the pins used in multiprocessor systems.

External Port Throughput

The throughput for the external port, based on 166 MHz clock and 32-bit data bus, is 221M bytes/s for the AMI and 664M bytes/s for SDRAM.

Asynchronous Memory Controller

The asynchronous memory controller provides a configurable interface for up to four separate banks of memory or I/O devices. Each bank can be independently programmed with different timing parameters, enabling connection to a wide variety of memory devices including SRAM, ROM, flash, and EPROM, as well as I/O devices that interface with standard memory control lines. Bank 0 occupies a 14M word window and Banks 1, 2, and 3 occupy a 16M word window in the processor's address space but, if not fully populated, these windows are not made contiguous by the memory controller logic. The banks can also be configured as 8-bit, 16-bit, or 32-bit wide buses for ease of interfacing to a range of memories and I/O devices tailored either to high performance or to low cost and power.

Pulse-Width Modulation

The PWM module is a flexible, programmable, PWM waveform generator that can be programmed to generate the required switching patterns for various applications related to motor and engine control or audio power control. The PWM generator can generate either center-aligned or edge-aligned PWM waveforms. In addition, it can generate complementary signals on two outputs in paired mode or independent signals in non-paired mode (applicable to a single group of four PWM waveforms).

The entire PWM module has four groups of four PWM outputs each. Therefore, this module generates 16 PWM outputs in total. Each PWM group produces two pairs of PWM signals on the four PWM outputs.

The PWM generator is capable of operating in two distinct modes while generating center-aligned PWM waveforms: single update mode or double update mode. In single update mode, the duty cycle values are programmable only once per PWM period. This results in PWM patterns that are symmetrical about the midpoint of the PWM period. In double update mode, a second updating of the PWM registers is implemented at the midpoint of the PWM period. In this mode, it is possible to produce asymmetrical PWM patterns that produce lower harmonic distortion in 2-phase PWM inverters.

Digital Applications Interface (DAI)

The digital applications interface (DAI) provides the ability to connect various peripherals to any of the DAI pins of the DSP (DAI_P20–1). Programs make these connections using the signal routing unit (SRU1), shown in [Figure 1](#).

The SRU is a matrix routing unit (or group of multiplexers) that enables the peripherals provided by the DAI to be interconnected under software control. This allows easy use of the associated peripherals for a much wider variety of applications by using a larger set of algorithms than is possible with nonconfigurable signal paths.

The DAI includes eight serial ports, an S/PDIF receiver/transmitter, four precision clock generators (PCG), eight channels of synchronous sample rate converters, and an input data port (IDP). The IDP provides an additional input path to the processor core, configurable as either eight channels of I²S serial

data or as seven channels plus a single 20-bit wide synchronous parallel data acquisition port. Each data channel has its own DMA channel that is independent from the processor's serial ports.

For complete information on using the DAI, see the [ADSP-2137x SHARC Processor Hardware Reference](#).

Serial Ports

The processors feature eight synchronous serial ports (SPORTs) that provide an inexpensive interface to a wide variety of digital and mixed-signal peripheral devices such as Analog Devices' AD183x family of audio codecs, ADCs, and DACs. The serial ports are made up of two data lines, a clock, and frame sync. The data lines can be programmed to either transmit or receive and each data line has a dedicated DMA channel.

Serial ports are enabled via 16 programmable and simultaneous receive or transmit pins that support up to 32 transmit or 32 receive channels of audio data when all eight SPORTs are enabled, or eight full duplex TDM streams of 128 channels per frame.

The serial ports operate at a maximum data rate of 50 Mbps. Serial port data can be automatically transferred to and from on-chip memory via dedicated DMA channels. Each of the serial ports can work in conjunction with another serial port to provide TDM support. One SPORT provides two transmit signals while the other SPORT provides the two receive signals. The frame sync and clock are shared.

Serial ports operate in five modes:

- Standard DSP serial mode
- Multichannel (TDM) mode with support for packed I²S mode
- I²S mode
- Packed I²S mode
- Left-justified sample pair mode

Left-justified sample pair mode is a mode where in each frame sync cycle two samples of data are transmitted/received—one sample on the high segment of the frame sync, the other on the low segment of the frame sync. Programs have control over various attributes of this mode.

Each of the serial ports supports the left-justified sample pair and I²S protocols (I²S is an industry-standard interface commonly used by audio codecs, ADCs, and DACs such as the Analog Devices AD183x family), with two data pins, allowing four left-justified sample pair or I²S channels (using two stereo devices) per serial port, with a maximum of up to 32 I²S channels. The serial ports permit little-endian or big-endian transmission formats and word lengths selectable from 3 bits to 32 bits. For the left-justified sample pair and I²S modes, data-word lengths are selectable between 8 bits and 32 bits. Serial ports offer selectable synchronization and transmit modes as well as optional μ -law or A-law companding selection on a per channel basis. Serial port clocks and frame syncs can be internally or externally generated.

The serial ports also contain frame sync error detection logic where the serial ports detect frame syncs that arrive early (for example, frame syncs that arrive while the transmission/reception of the previous word is occurring). All the serial ports also share one dedicated error interrupt.

S/PDIF-Compatible Digital Audio Receiver/Transmitter

The S/PDIF receiver/transmitter has no separate DMA channels. It receives audio data in serial format and converts it into a biphasic encoded signal. The serial data input to the receiver/transmitter can be formatted as left-justified, I²S, or right-justified with word widths of 16, 18, 20, or 24 bits.

The serial data, clock, and frame sync inputs to the S/PDIF receiver/transmitter are routed through the signal routing unit (SRU). They can come from a variety of sources such as the SPORTs, external pins, the precision clock generators (PCGs), or the sample rate converters (SRC) and are controlled by the SRU control registers.

Synchronous/Asynchronous Sample Rate Converter

The sample rate converter (SRC) contains four SRC blocks and is the same core as that used in the AD1896 192 kHz stereo asynchronous sample rate converter and provides up to 128 dB SNR. The SRC block is used to perform synchronous or asynchronous sample rate conversion across independent stereo channels, without using internal processor resources. The four SRC blocks can also be configured to operate together to convert multichannel audio data without phase mismatches. Finally, the SRC can be used to clean up audio data from jittery clock sources such as the S/PDIF receiver.

Input Data Port

The IDP provides up to eight serial input channels—each with its own clock, frame sync, and data inputs. The eight channels are automatically multiplexed into a single 32-bit by eight-deep FIFO. Data is always formatted as a 64-bit frame and divided into two 32-bit words. The serial protocol is designed to receive audio channels in I²S, left-justified sample pair, or right-justified mode. One frame sync cycle indicates one 64-bit left/right pair, but data is sent to the FIFO as 32-bit words (that is, one-half of a frame at a time). The processor supports 24- and 32-bit I²S, 24- and 32-bit left-justified, and 24-, 20-, 18- and 16-bit right-justified formats.

Precision Clock Generators

The precision clock generators (PCG) consist of four units, each of which generates a pair of signals (clock and frame sync) derived from a clock input signal. The units, A, B, C, and D, are identical in functionality and operate independently of each other. The two signals generated by each unit are normally used as a serial bit clock/frame sync pair.

Digital Peripheral Interface (DPI)

The digital peripheral interface provides connections to two serial peripheral interface ports (SPI), two universal asynchronous receiver-transmitters (UARTs), a 2-wire interface (TWI), 12 flags, and three general-purpose timers.

Serial Peripheral (Compatible) Interface

The processors contain two serial peripheral interface ports (SPIs). The SPI is an industry-standard synchronous serial link, enabling the SPI-compatible port to communicate with other SPI-compatible devices. The SPI consists of two data pins, one device select pin, and one clock pin. It is a full-duplex synchronous serial interface, supporting both master and slave modes. The SPI port can operate in a multimaster environment by interfacing with up to four other SPI-compatible devices, either acting as a master or slave device. The SPI-compatible peripheral implementation also features programmable baud rate and clock phase and polarities. The SPI-compatible port uses open-drain drivers to support a multimaster configuration and to avoid data contention.

UART Port

The processors provide a full-duplex universal asynchronous receiver/transmitter (UART) port, which is fully compatible with PC-standard UARTs. The UART port provides a simplified UART interface to other peripherals or hosts, supporting full-duplex, DMA-supported, asynchronous transfers of serial data. The UART also has multiprocessor communication capability using 9-bit address detection. This allows it to be used in multidrop networks through the RS-485 data interface standard. The UART port also includes support for five data bits to eight data bits, one stop bit or two stop bits, and none, even, or odd parity. The UART port supports two modes of operation:

- PIO (programmed I/O) – The processor sends or receives data by writing or reading I/O-mapped UART registers. The data is double-buffered on both transmit and receive.
- DMA (direct memory access) – The DMA controller transfers both transmit and receive data. This reduces the number and frequency of interrupts required to transfer data to and from memory. The UART has two dedicated DMA channels, one for transmit and one for receive. These DMA channels have lower default priority than most DMA channels because of their relatively low service rates.

The UART port's baud rate, serial data format, error code generation and status, and interrupts are programmable:

- Supporting bit rates ranging from ($f_{\text{SCLK}}/1,048,576$) to ($f_{\text{SCLK}}/16$) bits per second.
- Supporting data formats from 7 bits to 12 bits per frame.
- Both transmit and receive operations can be configured to generate maskable interrupts to the processor.

Where the 16-bit UART_Divisor comes from the DLH register (most significant eight bits) and DLL register (least significant eight bits).

In conjunction with the general-purpose timer functions, auto-baud detection is supported.

Peripheral Timers

Three general-purpose timers can generate periodic interrupts and be independently set to operate in one of three modes:

- Pulse waveform generation mode
- Pulse width count/capture mode
- External event watchdog mode

Each general-purpose timer has one bidirectional pin and four registers that implement its mode of operation: a 6-bit configuration register, a 32-bit count register, a 32-bit period register, and a 32-bit pulse width register. A single control and status register enables or disables all three general-purpose timers independently.

2-Wire Interface Port (TWI)

The TWI is a bidirectional 2-wire serial bus used to move 8-bit data while maintaining compliance with the I²C bus protocol. The TWI master incorporates the following features:

- Simultaneous master and slave operation on multiple device systems with support for multimaster data arbitration
- Digital filtering and timed event processing
- 7-bit and 10-bit addressing
- 100 kbps and 400 kbps data rates
- Low interrupt rate

I/O PROCESSOR FEATURES

The I/O processor provides many channels of DMA, and controls the extensive set of peripherals described in the previous sections.

DMA Controller

The processor's on-chip DMA controller allows data transfers without processor intervention. The DMA controller operates independently and invisibly to the processor core, allowing DMA operations to occur while the core is simultaneously executing its program instructions. DMA transfers can occur between the processor's internal memory and its serial ports, the SPI-compatible (serial peripheral interface) ports, the IDP (input data port), the parallel data acquisition port (PDAP), or the UART.

Thirty four channels of DMA are available on the ADSP-2136x processors as shown in [Table 6](#).

Table 6. DMA Channels

Peripheral	DMA Channels
SPORTs	16
PDAP	8
SPI	2
UART	4
External Port	2
Memory-to-Memory	2

Delay Line DMA

The processor provides delay line DMA functionality. This allows processor reads and writes to external delay line buffers (in external memory, SRAM, or SDRAM) with limited core interaction.

SYSTEM DESIGN

The following sections provide an introduction to system design options and power supply issues.

Program Booting

The internal memory of the processors can be booted up at system power-up from an 8-bit EPROM via the external port, an SPI master or slave, or an internal boot. Booting is determined by the boot configuration (BOOT_CFG1–0) pins (see [Table 7](#) and the processor hardware reference). Selection of the boot source is controlled via the SPI as either a master or slave device, or it can immediately begin executing from ROM.

Table 7. Boot Mode Selection

BOOT_CFG1–0	Booting Mode
00	SPI Slave Boot
01	SPI Master Boot
10	EPROM/FLASH Boot
11	No boot (processor executes from internal ROM after reset)

Power Supplies

The processors have separate power supply connections for the internal (V_{DDINT}), external (V_{DDEXT}), and analog (A_{VDD}/A_{VSS}) power supplies. The internal and analog supplies must meet the 1.3 V requirement for the 400 MHz device and 1.2 V for the 333 MHz and 266 MHz devices. The external supply must meet the 3.3 V requirement. All external supply pins must be connected to the same power supply.

Note that the analog supply pin (A_{VDD}) powers the processor's internal clock generator PLL. To produce a stable clock, it is recommended that PCB designs use an external filter circuit for the A_{VDD} pin. Place the filter components as close as possible to the A_{VDD}/A_{VSS} pins. For an example circuit, see [Figure 3](#). (A recommended ferrite chip is the muRata BLM18AG102SN1D). To reduce noise coupling, the PCB should use a parallel pair of power and ground planes for V_{DDINT} and GND. Use wide traces to connect the bypass capacitors to the analog power (A_{VDD}) and ground (A_{VSS}) pins. Note that the A_{VDD} and A_{VSS} pins specified in [Figure 3](#) are inputs to the processor and not the analog ground plane on the board—the A_{VSS} pin should connect directly to digital ground (GND) at the chip.

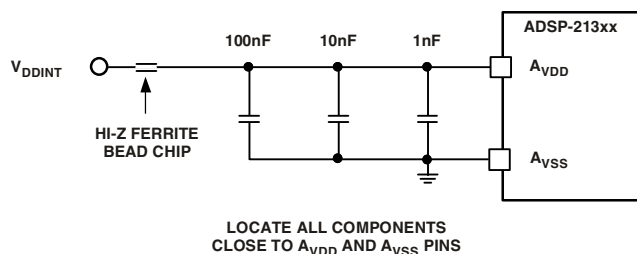

Figure 3. Analog Power (A_{VDD}) Filter Circuit

Target Board JTAG Emulator Connector

Analog Devices DSP Tools product line of JTAG emulators uses the IEEE 1149.1 JTAG test access port of the processor to monitor and control the target board processor during emulation. Analog Devices DSP Tools product line of JTAG emulators provides emulation at full processor speed, allowing inspection and modification of memory, registers, and processor stacks. The processor's JTAG interface ensures that the emulator will not affect target system loading or timing.

For complete information on Analog Devices' SHARC DSP Tools product line of JTAG emulator operation, see the appropriate "Emulator Hardware User's Guide."

DEVELOPMENT TOOLS

Analog Devices supports its processors with a complete line of software and hardware development tools, including integrated development environments (which include CrossCore[®] Embedded Studio and/or VisualDSP++[®]), evaluation products, emulators, and a wide variety of software add-ins.

Integrated Development Environments (IDEs)

For C/C++ software writing and editing, code generation, and debug support, Analog Devices offers two IDEs.

The newest IDE, CrossCore Embedded Studio, is based on the Eclipse[™] framework. Supporting most Analog Devices processor families, it is the IDE of choice for future processors, including multicore devices. CrossCore Embedded Studio seamlessly integrates available software add-ins to support real time operating systems, file systems, TCP/IP stacks, USB stacks, algorithmic software modules, and evaluation hardware board support packages. For more information visit www.analog.com/cces.

The other Analog Devices IDE, VisualDSP++, supports processor families introduced prior to the release of CrossCore Embedded Studio. This IDE includes the Analog Devices VDK real time operating system and an open source TCP/IP stack. For more information visit www.analog.com/visualdsp. Note that VisualDSP++ will not support future Analog Devices processors.

EZ-KIT Lite Evaluation Board

For processor evaluation, Analog Devices provides wide range of EZ-KIT Lite[®] evaluation boards. Including the processor and key peripherals, the evaluation board also supports on-chip

emulation capabilities and other evaluation and development features. Also available are various EZ-Extenders[®], which are daughter cards delivering additional specialized functionality, including audio and video processing. For more information visit www.analog.com and search on "ezkit" or "ezextender".

EZ-KIT Lite Evaluation Kits

For a cost-effective way to learn more about developing with Analog Devices processors, Analog Devices offer a range of EZ-KIT Lite evaluation kits. Each evaluation kit includes an EZ-KIT Lite evaluation board, directions for downloading an evaluation version of the available IDE(s), a USB cable, and a power supply. The USB controller on the EZ-KIT Lite board connects to the USB port of the user's PC, enabling the chosen IDE evaluation suite to emulate the on-board processor in-circuit. This permits the customer to download, execute, and debug programs for the EZ-KIT Lite system. It also supports in-circuit programming of the on-board Flash device to store user-specific boot code, enabling standalone operation. With the full version of CrossCore Embedded Studio or VisualDSP++ installed (sold separately), engineers can develop software for supported EZ-KITs or any custom system utilizing supported Analog Devices processors.

Software Add-Ins for CrossCore Embedded Studio

Analog Devices offers software add-ins which seamlessly integrate with CrossCore Embedded Studio to extend its capabilities and reduce development time. Add-ins include board support packages for evaluation hardware, various middleware packages, and algorithmic modules. Documentation, help, configuration dialogs, and coding examples present in these add-ins are viewable through the CrossCore Embedded Studio IDE once the add-in is installed.

Board Support Packages for Evaluation Hardware

Software support for the EZ-KIT Lite evaluation boards and EZ-Extender daughter cards is provided by software add-ins called Board Support Packages (BSPs). The BSPs contain the required drivers, pertinent release notes, and select example code for the given evaluation hardware. A download link for a specific BSP is located on the web page for the associated EZ-KIT or EZ-Extender product. The link is found in the *Product Download* area of the product web page.

ADSP-21369

Middleware Packages

Analog Devices separately offers middleware add-ins such as real time operating systems, file systems, USB stacks, and TCP/IP stacks. For more information see the following web pages:

- www.analog.com/ucos2
- www.analog.com/ucos3
- www.analog.com/ucfs
- www.analog.com/ucusbdb
- www.analog.com/ucusbh
- www.analog.com/lwip

Algorithmic Modules

To speed development, Analog Devices offers add-ins that perform popular audio and video processing algorithms. These are available for use with both CrossCore Embedded Studio and VisualDSP++. For more information visit www.analog.com and search on “Blackfin software modules” or “SHARC software modules”.

Designing an Emulator-Compatible DSP Board (Target)

For embedded system test and debug, Analog Devices provides a family of emulators. On each JTAG DSP, Analog Devices supplies an IEEE 1149.1 JTAG Test Access Port (TAP). In-circuit emulation is facilitated by use of this JTAG interface. The emulator accesses the processor’s internal features via the processor’s TAP, allowing the developer to load code, set breakpoints, and view variables, memory, and registers. The processor must be halted to send data and commands, but once an operation is completed by the emulator, the DSP system is set to run at full speed with no impact on system timing. The emulators require the target board to include a header that supports connection of the JTAG port of the DSP to the emulator.

For details on target board design issues including mechanical layout, single processor connections, signal buffering, signal termination, and emulator pod logic, see “[Analog Devices JTAG Emulation Technical Reference](#)” (EE-68). This document is updated regularly to keep pace with improvements to emulator support.

ADDITIONAL INFORMATION

This data sheet provides a general overview of the architecture and functionality of the ADSP-21369 processor. For detailed information on the ADSP-2136x family core architecture and instruction set, refer to the [ADSP-2137x SHARC Processor Hardware Reference](#) and the [SHARC Processor Programming Reference](#).

RELATED SIGNAL CHAINS

A signal chain is a series of signal-conditioning electronic components that receive input (data acquired from sampling either real-time phenomena or from stored data) in tandem, with the output of one portion of the chain supplying input to the next. Signal chains are often used in signal processing applications to gather and process data or to apply system controls based on analysis of real-time phenomena.

Analog Devices eases signal processing system development by providing signal processing components that are designed to work together well. A tool for viewing relationships between specific applications and related components is available on the www.analog.com website.

The application signal chains page in the Circuits from the Lab® site (<http://www.analog.com/circuits>) provides:

- Graphical circuit block diagram presentation of signal chains for a variety of circuit types and applications
- Drill down links for components in each chain to selection guides and application information
- Reference designs applying best practice design techniques

PIN FUNCTION DESCRIPTIONS

The following symbols appear in the Type column of [Table 8](#):

A = asynchronous, G = ground, I = input, O = output,
 O/T = output three-state, P = power supply, S = synchronous,
 (A/D) = active drive, (O/D) = open-drain, (pd) = pull-down
 resistor, (pu) = pull-up resistor.

The ADSP-21369 SHARC processors use extensive pin multiplexing to achieve a lower pin count. For complete information on the multiplexing scheme, see the [ADSP-2137x SHARC Processor Hardware Reference](#), “System Design” chapter.

Table 8. Pin Descriptions

Name	Type	State During/ After Reset (ID = 00x)	Description
ADDR ₂₃₋₀	O/T (pu) ¹	Pulled high/ driven low	External Address. The processors output addresses for external memory and peripherals on these pins.
DATA ₃₁₋₀	I/O (pu) ¹	Pulled high/ pulled high	External Data. Data pins can be multiplexed to support external memory interface data (I/O), the PDAP (I), FLAGS (I/O), and PWM (O). After reset, all DATA pins are in EMIF mode and FLAG(0-3) pins are in FLAGS mode (default). When configured using the IDP_P-DAP_CTL register, IDP Channel 0 scans the external port data pins for parallel input data.
ACK	I (pu) ¹		Memory Acknowledge. External devices can deassert ACK (low) to add wait states to an external memory access. ACK is used by I/O devices, memory controllers, or other peripherals to hold off completion of an external memory access.
\overline{MS}_{0-1}	O/T (pu) ¹	Pulled high/ driven high	Memory Select Lines 0–1. These lines are asserted (low) as chip selects for the corresponding banks of external memory. The \overline{MS}_{3-0} lines are decoded memory address lines that change at the same time as the other address lines. When no external memory access is occurring, the \overline{MS}_{3-0} lines are inactive; they are active, however, when a conditional memory access instruction is executed, whether or not the condition is true. The \overline{MS}_1 pin can be used in EPORT/FLASH boot mode. See the processor hardware reference for more information.
\overline{RD}	O/T (pu) ¹	Pulled high/ driven high	External Port Read Enable. \overline{RD} is asserted whenever the processors read a word from external memory.
\overline{WR}	O/T (pu) ¹	Pulled high/ driven high	External Port Write Enable. \overline{WR} is asserted when the processors write a word to external memory.
FLAG[0]/ $\overline{IRQ0}$	I/O	FLAG[0] INPUT	FLAG0/Interrupt Request 0.
FLAG[1]/ $\overline{IRQ1}$	I/O	FLAG[1] INPUT	FLAG1/Interrupt Request 1.
FLAG[2]/ $\overline{IRQ2}$ / \overline{MS}_2	I/O with programmable pu (for MS mode)	FLAG[2] INPUT	FLAG2/Interrupt Request 2/Memory Select 2.
FLAG[3]/ TMREXP/ \overline{MS}_3	I/O with programmable pu (for MS mode)	FLAG[3] INPUT	FLAG3/Timer Expired/Memory Select 3.

ADSP-21369

Table 8. Pin Descriptions (Continued)

Name	Type	State During/ After Reset (ID = 00x)	Description
$\overline{\text{SDRAS}}$	O/T (pu) ¹	Pulled high/ driven high	SDRAM Row Address Strobe. Connect to SDRAM's RAS pin. In conjunction with other SDRAM command pins, defines the operation for the SDRAM to perform.
$\overline{\text{SDCAS}}$	O/T (pu) ¹	Pulled high/ driven high	SDRAM Column Address Select. Connect to SDRAM's CAS pin. In conjunction with other SDRAM command pins, defines the operation for the SDRAM to perform.
$\overline{\text{SDWE}}$	O/T (pu) ¹	Pulled high/ driven high	SDRAM Write Enable. Connect to SDRAM's WE or W buffer pin.
SDCKE	O/T (pu) ¹	Pulled high/ driven high	SDRAM Clock Enable. Connect to SDRAM's CKE pin. Enables and disables the CLK signal. For details, see the data sheet supplied with the SDRAM device.
SDA10	O/T (pu) ¹	Pulled high/ driven low	SDRAM A10 Pin. Enables applications to refresh an SDRAM in parallel with non-SDRAM accesses. This pin replaces the DSP's A10 pin only during SDRAM accesses.
SDCLK0	O/T	High-Z/driving	SDRAM Clock Output 0. Clock driver for this pin differs from all other clock drivers. See Figure 39 .
SDCLK1	O/T		SDRAM Clock Output 1. Additional clock for SDRAM devices. For systems with multiple SDRAM devices, handles the increased clock load requirements, eliminating need of off-chip clock buffers. Either SDCLK1 or both SDCLKx pins can be three-stated. Clock driver for this pin differs from all other clock drivers. See Figure 39 . The SDCLK1 signal is only available on the FCBGA package. SDCLK1 is not available on the LQFP_EP package.
DAI_P ₂₀₋₁	I/O with programmable pu ²	Pulled high/ pulled high	Digital Applications Interface. These pins provide the physical interface to the DAI SRU. The DAI SRU configuration registers define the combination of on-chip audiocentric peripheral inputs or outputs connected to the pin, and to the pin's output enable. The configuration registers then determines the exact behavior of the pin. Any input or output signal present in the DAI SRU may be routed to any of these pins. The DAI SRU provides the connection from the serial ports (8), the SRC module, the S/PDIF module, input data ports (2), and the precision clock generators (4), to the DAI_P20-1 pins. Pull-ups can be disabled via the DAI_PIN_PULLUP register.
DPI_P ₁₄₋₁	I/O with programmable pu ²	Pulled high/ pulled high	Digital Peripheral Interface. These pins provide the physical interface to the DPI SRU. The DPI SRU configuration registers define the combination of on-chip peripheral inputs or outputs connected to the pin and to the pin's output enable. The configuration registers of these peripherals then determines the exact behavior of the pin. Any input or output signal present in the DPI SRU may be routed to any of these pins. The DPI SRU provides the connection from the timers (3), SPIs (2), UARTs (2), flags (12) TWI (1), and general-purpose I/O (9) to the DPI_P14-1 pins. The TWI output is an open-drain output—so the pins used for I ² C data and clock should be connected to logic level 0. Pull-ups can be disabled via the DPI_PIN_PULLUP register.
TDI	I (pu)		Test Data Input (JTAG). Provides serial data for the boundary scan logic.
TDO	O/T		Test Data Output (JTAG). Serial scan output of the boundary scan path.
TMS	I (pu)		Test Mode Select (JTAG). Used to control the test state machine.
TCK	I		Test Clock (JTAG). Provides a clock for JTAG boundary scan. TCK must be asserted (pulsed low) after power-up, or held low for proper operation of the processor
$\overline{\text{TRST}}$	I (pu)		Test Reset (JTAG). Resets the test state machine. $\overline{\text{TRST}}$ must be asserted (pulsed low) after power-up or held low for proper operation of the processor.

Table 8. Pin Descriptions (Continued)

Name	Type	State During/ After Reset (ID = 00x)	Description
$\overline{\text{EMU}}$	O (O/D, pu)		Emulation Status. Must be connected to the processor Analog Devices DSP Tools product line of JTAG emulator target board connectors only.
CLK_CFG ₁₋₀	I		Core/CLKIN Ratio Control. These pins set the start-up clock frequency. See the processor hardware reference for a description of the clock configuration modes. Note that the operating frequency can be changed by programming the PLL multiplier and divider in the PMCTL register at any time after the core comes out of reset. Local Clock In. Used with XTAL. CLKIN is the processor's clock input. It configures the processors to use either its internal clock generator or an external clock source. Connecting the necessary components to CLKIN and XTAL enables the internal clock generator. Connecting the external clock to CLKIN while leaving XTAL unconnected configures the processor to use an external clock such as an external clock oscillator. CLKIN may not be halted, changed, or operated below the specified frequency. Crystal Oscillator Terminal. Used in conjunction with CLKIN to drive an external crystal.
CLKIN	I		
XTAL	O		
$\overline{\text{RESET}}$	I		Processor Reset. Resets the processor to a known state. Upon deassertion, there is a 4096 CLKIN cycle latency for the PLL to lock. After this time, the core begins program execution from the hardware reset vector address. The $\overline{\text{RESET}}$ input must be asserted (low) at power-up.
$\overline{\text{RESETOUT}}$	O	Driven low/ driven high	Reset Out. Drives out the core reset signal to an external device.
BOOT_CFG ₁₋₀	I		Boot Configuration Select. These pins select the boot mode for the processor. The BOOT_CFG pins must be valid before reset is asserted. See the processor hardware reference for a description of the boot modes.
$\overline{\text{BR}}_{4-1}$	I/O (pu) ¹	Pulled high/ pulled high	External Bus Request. Used to arbitrate for bus mastership. A processor only drives its own $\overline{\text{BR}}_x$ line (corresponding to the value of its ID ₂₋₀ inputs) and monitors all others. In a system with less than four processors, the unused $\overline{\text{BR}}_x$ pins should be tied high; the processor's own $\overline{\text{BR}}_x$ line must not be tied high or low because it is an output. Processor ID. Determines which bus request ($\overline{\text{BR}}_{4-1}$) is used by the processor. ID = 001 corresponds to $\overline{\text{BR}}_1$, ID = 010 corresponds to $\overline{\text{BR}}_2$, and so on. Use ID = 000 or 001 in single-processor systems. These lines are a system configuration selection that should be hardwired or only changed at reset. ID = 101, 110, and 111 are reserved. Rotating Priority Bus Arbitration Select. When RPBA is high, rotating priority for external bus arbitration is selected. When RPBA is low, fixed priority is selected. This signal is a system configuration selection which must be set to the same value on every processor in the system.
ID ₂₋₀	I (pd)		
RPBA	I (pu) ¹		

¹ The pull-up is always enabled.

² Pull-up can be enabled/disabled, value of pull-up cannot be programmed.

ADSP-21369

SPECIFICATIONS

OPERATING CONDITIONS

Parameter ¹	Description	400 MHz		366 MHz 350 MHz		333 MHz 266 MHz		Unit
		Min	Max	Min	Max	Min	Max	
V _{DDINT}	Internal (Core) Supply Voltage	1.25	1.35	1.235	1.365	1.14	1.26	V
A _{VDD}	Analog (PLL) Supply Voltage	1.25	1.35	1.235	1.365	1.14	1.26	V
V _{DDEXT}	External (I/O) Supply Voltage	3.13	3.47	3.13	3.47	3.13	3.47	V
V _{IH} ²	High Level Input Voltage @ V _{DDEXT} = Max	2.0	V _{DDEXT} + 0.5	2.0	V _{DDEXT} + 0.5	2.0	V _{DDEXT} + 0.5	V
V _{IL} ²	Low Level Input Voltage @ V _{DDEXT} = Min	-0.5	+0.8	-0.5	+0.8	-0.5	+0.8	V
V _{IH_CLKIN} ³	High Level Input Voltage @ V _{DDEXT} = Max	1.74	V _{DDEXT} + 0.5	1.74	V _{DDEXT} + 0.5	1.74	V _{DDEXT} + 0.5	V
V _{IL_CLKIN} ³	Low Level Input Voltage @ V _{DDEXT} = Min	-0.5	+1.1	-0.5	+1.1	-0.5	+1.1	V
T _J	Junction Temperature 208-Lead LQFP_EP @ T _{AMBIENT} 0°C to 70°C	0	95	0	110	0	110	°C
T _J	Junction Temperature 208-Lead LQFP_EP @ T _{AMBIENT} -40°C to +85°C	N/A	N/A	N/A	N/A	-40	+120	°C
T _J	Junction Temperature 256-Ball BGA_ED @ T _{AMBIENT} 0°C to 70°C	0	95	N/A	N/A	0	105	°C
T _J	Junction Temperature 256-Ball BGA_ED @ T _{AMBIENT} -40°C to +85°C	N/A	N/A	N/A	N/A	-40	+105	°C

¹ Specifications subject to change without notice.

² Applies to input and bidirectional pins: DATAx, ACK, RPBA, $\overline{\text{BRx}}$, IDx, FLAGx, DAI_Px, DPI_Px, BOOT_CFGx, CLK_CFGx, $\overline{\text{RESET}}$, TCK, TMS, TDI, $\overline{\text{TRST}}$.

³ Applies to input pin CLKIN.

ELECTRICAL CHARACTERISTICS

Parameter	Description	Test Conditions	Min	Typ	Max	Unit
V_{OH}^1	High Level Output Voltage	@ $V_{DDEXT} = \text{Min}$, $I_{OH} = -1.0 \text{ mA}^2$	2.4			V
V_{OL}^1	Low Level Output Voltage	@ $V_{DDEXT} = \text{Min}$, $I_{OL} = 1.0 \text{ mA}^2$			0.4	V
$I_{IH}^{3,4}$	High Level Input Current	@ $V_{DDEXT} = \text{Max}$, $V_{IN} = V_{DDEXT} \text{ Max}$			10	μA
$I_{IL}^{3,5,6}$	Low Level Input Current	@ $V_{DDEXT} = \text{Max}$, $V_{IN} = 0 \text{ V}$			10	μA
I_{IHPP}^5	High Level Input Current Pull-Down	@ $V_{DDEXT} = \text{Max}$, $V_{IN} = 0 \text{ V}$			250	μA
I_{ILPU}^4	Low Level Input Current Pull-Up	@ $V_{DDEXT} = \text{Max}$, $V_{IN} = 0 \text{ V}$			200	μA
$I_{OZH}^{7,8}$	Three-State Leakage Current	@ $V_{DDEXT} = \text{Max}$, $V_{IN} = V_{DDEXT} \text{ Max}$			10	μA
$I_{OZL}^{7,9}$	Three-State Leakage Current	@ $V_{DDEXT} = \text{Max}$, $V_{IN} = 0 \text{ V}$			10	μA
I_{OZLPU}^8	Three-State Leakage Current Pull-Up	@ $V_{DDEXT} = \text{Max}$, $V_{IN} = 0 \text{ V}$			200	μA
$I_{DD-INTYP}^{10}$	Supply Current (Internal)	$t_{CLK} = 3.75 \text{ ns}$, $V_{DDINT} = 1.2 \text{ V}$, 25°C $t_{CLK} = 3.00 \text{ ns}$, $V_{DDINT} = 1.2 \text{ V}$, 25°C $t_{CLK} = 2.85 \text{ ns}$, $V_{DDINT} = 1.3 \text{ V}$, 25°C $t_{CLK} = 2.73 \text{ ns}$, $V_{DDINT} = 1.3 \text{ V}$, 25°C $t_{CLK} = 2.50 \text{ ns}$, $V_{DDINT} = 1.3 \text{ V}$, 25°C		700 900 1050 1080 1100		mA mA mA mA mA
A_{IDD}^{11}	Supply Current (Analog)	$A_{VDD} = \text{Max}$			11	mA
C_{IN}^{12}	Input Capacitance	$f_{IN} = 1 \text{ MHz}$, $T_{CASE} = 25^\circ\text{C}$, $V_{IN} = 1.3 \text{ V}$			4.7	pF

¹ Applies to output and bidirectional pins: ADDR_x, DATA_x, $\overline{\text{RD}}$, $\overline{\text{WR}}$, $\overline{\text{MSx}}$, $\overline{\text{BRx}}$, FLAG_x, DAI_{Px}, DPI_{Px}, $\overline{\text{SDRAS}}$, $\overline{\text{SDCAS}}$, $\overline{\text{SDWE}}$, $\overline{\text{SDCKE}}$, SDA10, $\overline{\text{SDCLKx}}$, $\overline{\text{EMU}}$, $\overline{\text{TDO}}$.

² See [Output Drive Currents](#) for typical drive current capabilities.

³ Applies to input pins without internal pull-ups: BOOT_CFG_x, CLK_CFG_x, CLKIN, $\overline{\text{RESET}}$, TCK.

⁴ Applies to input pins with internal pull-ups: ACK, RPBA, TMS, TDI, $\overline{\text{TRST}}$.

⁵ Applies to input pins with internal pull-downs: ID_x.

⁶ Applies to input pins with internal pull-ups disabled: ACK, RPBA.

⁷ Applies to three-statable pins without internal pull-ups: FLAG_x, $\overline{\text{SDCLKx}}$, $\overline{\text{TDO}}$.

⁸ Applies to three-statable pins with internal pull-ups: ADDR_x, DATA_x, $\overline{\text{RD}}$, $\overline{\text{WR}}$, $\overline{\text{MSx}}$, $\overline{\text{BRx}}$, DAI_{Px}, DPI_{Px}, $\overline{\text{SDRAS}}$, $\overline{\text{SDCAS}}$, $\overline{\text{SDWE}}$, $\overline{\text{SDCKE}}$, SDA10, $\overline{\text{EMU}}$.

⁹ Applies to three-statable pins with internal pull-ups disabled: ADDR_x, DATA_x, $\overline{\text{RD}}$, $\overline{\text{WR}}$, $\overline{\text{MSx}}$, $\overline{\text{BRx}}$, DAI_{Px}, DPI_{Px}, $\overline{\text{SDRAS}}$, $\overline{\text{SDCAS}}$, $\overline{\text{SDWE}}$, $\overline{\text{SDCKE}}$, SDA10

¹⁰ See the Engineer-to-Engineer Note [“Estimating Power Dissipation for ADSP-21368 SHARC Processors” \(EE-299\)](#) for further information.

¹¹ Characterized, but not tested.

¹² Applies to all signal pins.

ESD CAUTION



ESD (electrostatic discharge) sensitive device. Charged devices and circuit boards can discharge without detection. Although this product features patented or proprietary protection circuitry, damage may occur on devices subjected to high energy ESD. Therefore, proper ESD precautions should be taken to avoid performance degradation or loss of functionality.

MAXIMUM POWER DISSIPATION

See the Engineer-to-Engineer Note [“Estimating Power Dissipation for ADSP-21368 SHARC Processors” \(EE-299\)](#) for detailed thermal and power information regarding maximum power dissipation. For information on package thermal specifications, see [Thermal Characteristics](#).

ABSOLUTE MAXIMUM RATINGS

Stresses at or above those listed in [Table 9](#) may cause permanent damage to the product. This is a stress rating only; functional operation of the product at these or any other conditions above those indicated in the operational section of this specification is not implied. Operation beyond the maximum operating conditions for extended periods may affect product reliability.

Table 9. Absolute Maximum Ratings

Parameter	Rating
Internal (Core) Supply Voltage (V_{DDINT})	-0.3 V to +1.5 V
Analog (PLL) Supply Voltage (A_{VDD})	-0.3 V to +1.5 V
External (I/O) Supply Voltage (V_{DDEXT})	-0.3 V to +4.6 V
Input Voltage	-0.5 V to +3.8 V
Output Voltage Swing	-0.5 V to $V_{DDEXT} + 0.5$ V
Load Capacitance	200 pF
Storage Temperature Range	-65°C to +150°C
Junction Temperature Under Bias	125°C

TIMING SPECIFICATIONS

Use the exact timing information given. Do not attempt to derive parameters from the addition or subtraction of others. While addition or subtraction would yield meaningful results for an individual device, the values given in this data sheet reflect statistical variations and worst cases. Consequently, it is not meaningful to add parameters to derive longer times. See [Figure 40](#) under [Test Conditions](#) for voltage reference levels.

Switching Characteristics specify how the processor changes its signals. Circuitry external to the processor must be designed for compatibility with these signal characteristics. Switching characteristics describe what the processor will do in a given circumstance. Use switching characteristics to ensure that any timing requirement of a device connected to the processor (such as memory) is satisfied.

Timing Requirements apply to signals that are controlled by circuitry external to the processor, such as the data input for a read operation. Timing requirements guarantee that the processor operates correctly with other devices.

Core Clock Requirements

The processor's internal clock (a multiple of CLKIN) provides the clock signal for timing internal memory, processor core, and serial ports. During reset, program the ratio between the processor's internal clock frequency and external (CLKIN) clock frequency with the CLK_CFG1-0 pins.

The processor's internal clock switches at higher frequencies than the system input clock (CLKIN). To generate the internal clock, the processor uses an internal phase-locked loop (PLL, see [Figure 4](#)). This PLL-based clocking minimizes the skew between the system clock (CLKIN) signal and the processor's internal clock.

Voltage Controlled Oscillator

In application designs, the PLL multiplier value should be selected in such a way that the VCO frequency never exceeds f_{VCO} specified in [Table 12](#).

- The product of CLKIN and PLLM must never exceed 1/2 of f_{VCO} (max) in [Table 12](#) if the input divider is not enabled (INDIV = 0).
- The product of CLKIN and PLLM must never exceed f_{VCO} (max) in [Table 12](#) if the input divider is enabled (INDIV = 1).

The VCO frequency is calculated as follows:

$$f_{VCO} = 2 \times PLLM \times f_{INPUT}$$

$$f_{CLK} = (2 \times PLLM \times f_{INPUT}) \div (2 \times PLLD)$$

where:

$$f_{VCO} = \text{VCO output}$$

$PLLM$ = Multiplier value programmed in the PMCTL register. During reset, the PLLM value is derived from the ratio selected using the CLK_CFG pins in hardware.

$PLLD$ = Divider value 1, 2, 4, or 8 based on the PLLD value programmed on the PMCTL register. During reset this value is 1.

f_{INPUT} = Input frequency to the PLL.

f_{INPUT} = CLKIN when the input divider is disabled or

f_{INPUT} = CLKIN \div 2 when the input divider is enabled

Note the definitions of the clock periods that are a function of CLKIN and the appropriate ratio control shown in and [Table 10](#). All of the timing specifications for the ADSP-2136x peripherals are defined in relation to t_{PCLK} . See the peripheral specific timing section for timing information for each peripheral.

Table 10. Clock Periods

Timing Requirements	Description
t_{CK}	CLKIN Clock Period
t_{CLK}	Processor Core Clock Period
t_{PCLK}	Peripheral Clock Period = $2 \times t_{CLK}$

[Figure 4](#) shows core to CLKIN relationships with external oscillator or crystal. The shaded divider/multiplier blocks denote where clock ratios can be set through hardware or software using the power management control register (PMCTL). For more information, see the processor hardware reference.

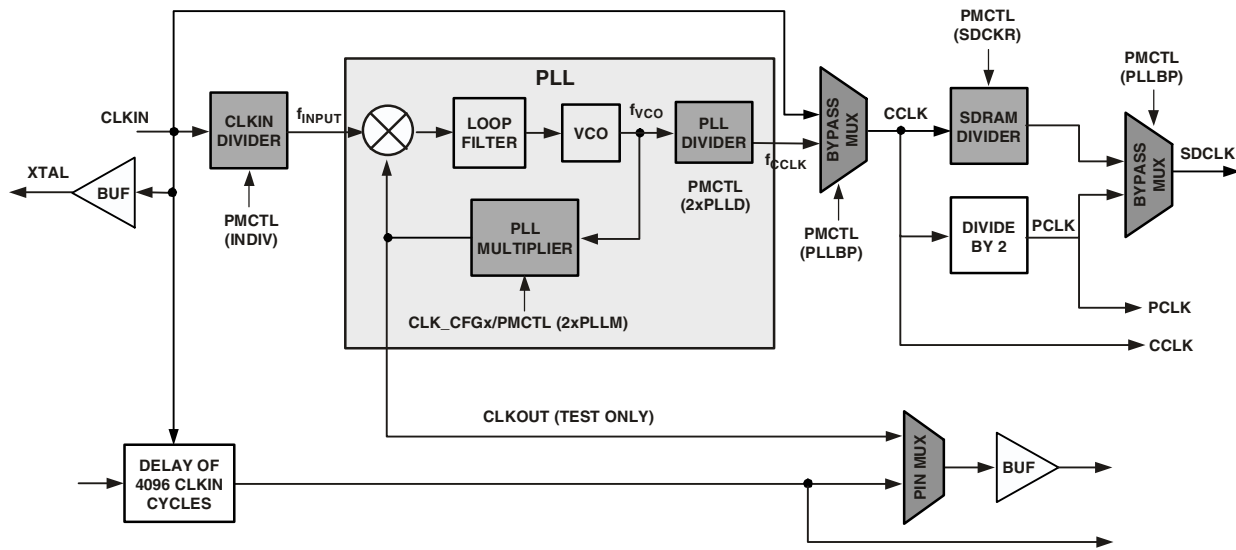

Figure 4. Core Clock and System Clock Relationship to CLKIN

Power-Up Sequencing

The timing requirements for processor start-up are given in [Table 11](#). Note that during power-up, a leakage current of approximately 200µA may be observed on the $\overline{\text{RESET}}$ pin if it is

driven low before power up is complete. This leakage current results from the weak internal pull-up resistor on this pin being enabled during power-up.

Table 11. Power-Up Sequencing Timing Requirements (Processor Start-up)

Parameter		Min	Max	Unit
<i>Timing Requirements</i>				
t_{RSTVDD}	$\overline{\text{RESET}}$ Low Before $V_{\text{DDINT}}/V_{\text{DDEXT}}$ On	0		ns
t_{VDDEVDD}	V_{DDINT} On Before V_{DDEXT}	-50	+200	ms
t_{CLKVDD}^1	CLKIN Valid After $V_{\text{DDINT}}/V_{\text{DDEXT}}$ Valid	0	200	ms
t_{CLKRST}	CLKIN Valid Before $\overline{\text{RESET}}$ Deasserted	10^2		µs
t_{PLLST}	PLL Control Setup Before $\overline{\text{RESET}}$ Deasserted	20		µs
<i>Switching Characteristic</i>				
t_{CORERST}	Core Reset Deasserted After $\overline{\text{RESET}}$ Deasserted	$4096t_{\text{CK}} + 2t_{\text{CLK}}^{3,4}$		

¹ Valid $V_{\text{DDINT}}/V_{\text{DDEXT}}$ assumes that the supplies are fully ramped to their 1.2 V rails and 3.3 V rails. Voltage ramp rates can vary from microseconds to hundreds of milliseconds depending on the design of the power supply subsystem.

² Assumes a stable CLKIN signal, after meeting worst-case start-up timing of crystal oscillators. Refer to your crystal oscillator manufacturer's data sheet for start-up time. Assume a 25 ms maximum oscillator start-up time if using the XTAL pin and internal oscillator circuit in conjunction with an external crystal.

³ Applies after the power-up sequence is complete. Subsequent resets require $\overline{\text{RESET}}$ to be held low a minimum of four CLKIN cycles in order to properly initialize and propagate default states at all I/O pins.

⁴ The 4096 cycle count depends on t_{rst} specification in [Table 13](#). If setup time is not met, 1 additional CLKIN cycle may be added to the core reset time, resulting in 4097 cycles maximum.

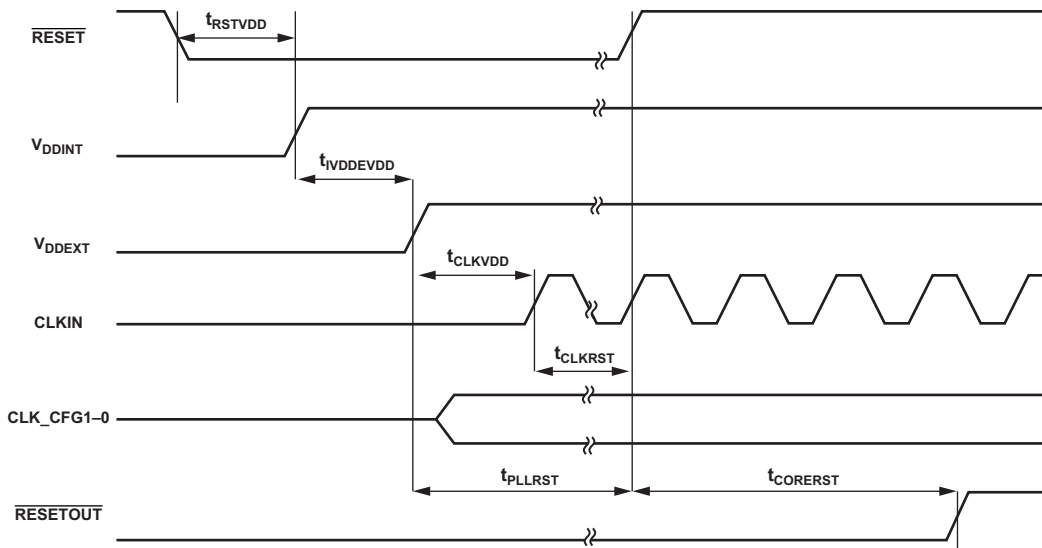

Figure 5. Power-Up Sequencing

Clock Input

Table 12. Clock Input

Parameter	400 MHz ¹		366 MHz ²		350 MHz ³		333 MHz ⁴		266 MHz ⁵		Unit
	Min	Max	Min	Max	Min	Max	Min	Max	Min	Max	
<i>Timing Requirements</i>											
t_{CK} CLKIN Period	15 ⁶	100	16.39 ⁶	100	17.14 ⁶	100	18 ⁶	100	22.5 ⁶	100	ns
t_{CKL} CLKIN Width Low	7.5 ¹	45	8.1 ¹	45	8.5 ¹	45	9 ¹	45	11.25 ¹	45	ns
t_{CKH} CLKIN Width High	7.5 ¹	45	8.1 ¹	45	8.5 ¹	45	9 ¹	45	11.25 ¹	45	ns
t_{CKRF} CLKIN Rise/Fall (0.4 V to 2.0 V)		3		3		3		3		3	ns
t_{CCLK} ⁷ CCLK Period	2.5 ⁶	10	2.73 ⁶	10	2.85 ⁶	10	3.0 ⁶	10	3.75 ⁶	10	ns
f_{VCO} ⁸ VCO Frequency	100	800	100	800	100	800	100	800	100	600	MHz
t_{CKJ} ^{9,10} CLKIN Jitter Tolerance	-250	+250	-250	+250	-250	+250	-250	+250	-250	+250	ps

¹ Applies to all 400 MHz models. See [Ordering Guide](#).

² Applies to all 366 MHz models. See [Ordering Guide](#).

³ Applies to all 350 MHz models. See [Ordering Guide](#).

⁴ Applies to all 333 MHz models. See [Ordering Guide](#).

⁵ Applies to all 266 MHz models. See [Ordering Guide](#).

⁶ Applies only for CLK_CFG1-0 = 00 and default values for PLL control bits in PMCTL.

⁷ Any changes to PLL control bits in the PMCTL register must meet core clock timing specification t_{CCLK} .

⁸ See [Figure 4](#) for VCO diagram.

⁹ Actual input jitter should be combined with ac specifications for accurate timing analysis.

¹⁰ jitter specification is maximum peak-to-peak time interval error (TIE) jitter.

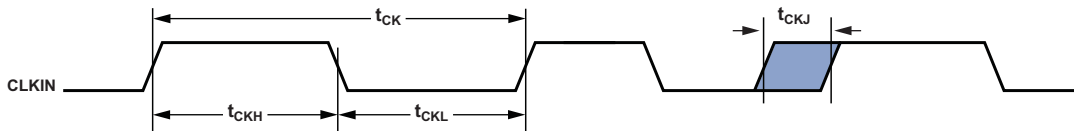

Figure 6. Clock Input

ADSP-21369

Clock Signals

The processors can use an external clock or a crystal. See the CLKIN pin description in [Table 8](#). Programs can configure the processor to use its internal clock generator by connecting the necessary components to CLKIN and XTAL. [Figure 7](#) shows the component connections used for a crystal operating in fundamental mode.

Note that the clock rate is achieved using a 25 MHz crystal and a PLL multiplier ratio 16:1 (CCLK:CLKIN achieves a clock speed of 400 MHz). To achieve the full core clock rate, programs need to configure the multiplier bits in the PMCTL register.

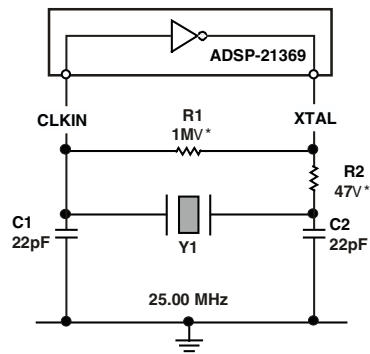

R2 SHOULD BE CHOSEN TO LIMIT CRYSTAL DRIVE POWER. REFER TO CRYSTAL MANUFACTURER'S SPECIFICATIONS

Figure 7. 400 MHz Operation (Fundamental Mode Crystal)

Reset

Table 13. Reset

Parameter	Min	Max	Unit
<i>Timing Requirements</i>			
t_{WRST}^1 \overline{RESET} Pulse Width Low	$4t_{CK}$		ns
t_{SRST} \overline{RESET} Setup Before CLKIN Low	8		ns

¹ Applies after the power-up sequence is complete. At power-up, the processor's internal phase-locked loop requires no more than 100 μ s while \overline{RESET} is low, assuming stable V_{DD} and CLKIN (not including start-up time of external clock oscillator).

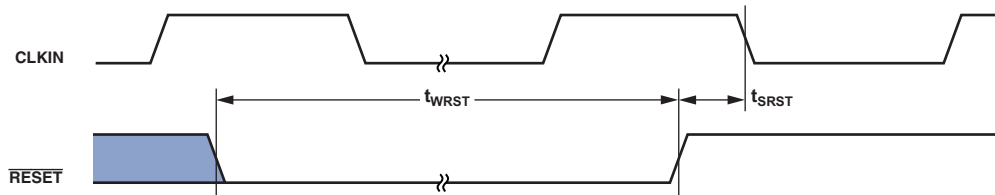

Figure 8. Reset

Interrupts

The following timing specification applies to the FLAG0, FLAG1, and FLAG2 pins when they are configured as $\overline{IRQ0}$, $\overline{IRQ1}$, and $\overline{IRQ2}$ interrupts.

Table 14. Interrupts

Parameter	Min	Max	Unit
<i>Timing Requirement</i>			
t_{IPW} \overline{IRQx} Pulse Width	$2 \times t_{PCLK} + 2$		ns

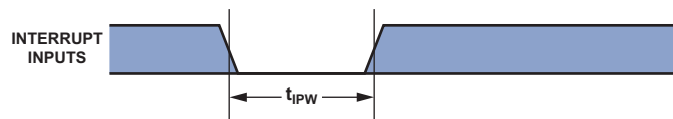

Figure 9. Interrupts

ADSP-21369

Core Timer

The following timing specification applies to FLAG3 when it is configured as the core timer (TMREXP).

Table 15. Core Timer

Parameter	Min	Max	Unit
<i>Switching Characteristic</i>			
t_{WCTIM} TMREXP Pulse Width	$4 \times t_{PCLK} - 1$		ns

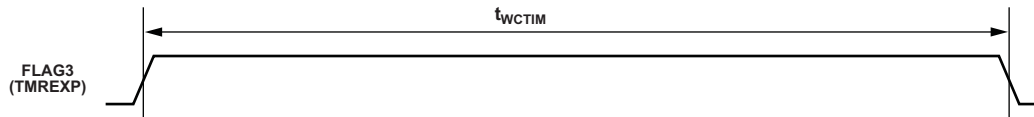

Figure 10. Core Timer

Timer PWM_OUT Cycle Timing

The following timing specification applies to Timer0, Timer1, and Timer2 in PWM_OUT (pulse-width modulation) mode. Timer signals are routed to the DPI_P14-1 pins through the DPI SRU. Therefore, the timing specifications provided below are valid at the DPI_P14-1 pins.

Table 16. Timer PWM_OUT Timing

Parameter	Min	Max	Unit
<i>Switching Characteristic</i>			
t_{PWMO} Timer Pulse Width Output	$2 \times t_{PCLK} - 1.2$	$2 \times (2^{31} - 1) \times t_{PCLK}$	ns

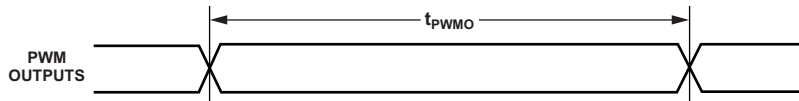

Figure 11. Timer PWM_OUT Timing

Timer WDT_H_CAP Timing

The following specification applies to Timer0, Timer1, and Timer2 in WDT_H_CAP (pulse width count and capture) mode. Timer signals are routed to the DPI_P14–1 pins through the DPI SRU. Therefore, the specification provided in Table 17 is valid at the DPI_P14–1 pins.

Table 17. Timer Width Capture Timing

Parameter	Min	Max	Unit
<i>Switching Characteristic</i>			
t_{PWI} Timer Pulse Width	$2 \times t_{PCLK}$	$2 \times (2^{31} - 1) \times t_{PCLK}$	ns

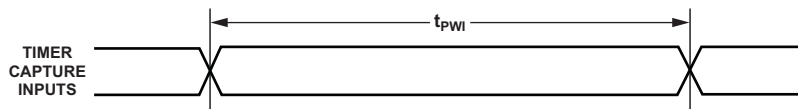

Figure 12. Timer Width Capture Timing

Pin to Pin Direct Routing (DAI and DPI)

For direct pin connections only (for example, DAI_PB01_I to DAI_PB02_O).

Table 18. DAI/DPI Pin to Pin Routing

Parameter	Min	Max	Unit
<i>Timing Requirement</i>			
t_{DPIO} Delay DAI/DPI Pin Input Valid to DAI/DPI Output Valid	1.5	12	ns

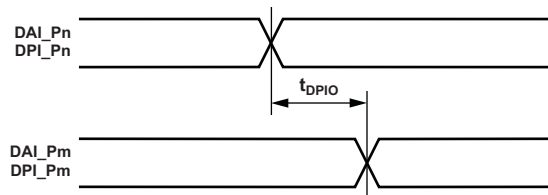

Figure 13. DAI/DPI Pin to Pin Direct Routing

ADSP-21369

Precision Clock Generator (Direct Pin Routing)

This timing is only valid when the SRU is configured such that the precision clock generator (PCG) takes its inputs directly from the DAI pins (via pin buffers) and sends its outputs directly to the DAI pins. For the other cases, where the PCG's

inputs and outputs are not directly routed to/from DAI pins (via pin buffers) there is no timing data available. All timing parameters and switching characteristics apply to external DAI pins (DAI_P01-20).

Table 19. Precision Clock Generator (Direct Pin Routing)

Parameter	Min	Max	Unit
<i>Timing Requirements</i>			
t_{PCGIP} Input Clock Period	$t_{PCLK} \times 4$		ns
t_{STRIG} PCG Trigger Setup Before Falling Edge of PCG Input Clock	4.5		ns
t_{HTRIG} PCG Trigger Hold After Falling Edge of PCG Input Clock	3		ns
<i>Switching Characteristics</i>			
t_{DPCGIO} PCG Output Clock and Frame Sync Active Edge Delay After PCG Input Clock	2.5	10	ns
$t_{DTRIGCLK}$ PCG Output Clock Delay After PCG Trigger	$2.5 + (2.5 \times t_{PCGIP})$	$10 + (2.5 \times t_{PCGIP})$	ns
$t_{DTRIGFS}$ PCG Frame Sync Delay After PCG Trigger	$2.5 + ((2.5 + D - PH) \times t_{PCGIP})$	$10 + ((2.5 + D - PH) \times t_{PCGIP})$	ns
t_{PCGOW}^1 Output Clock Period	$2 \times t_{PCGIP} - 1$		ns

D = FSxDIV, and PH = FSxPHASE. For more information, see the [ADSP-2137x SHARC Processor Hardware Reference](#), "Precision Clock Generators" chapter.

¹In normal mode.

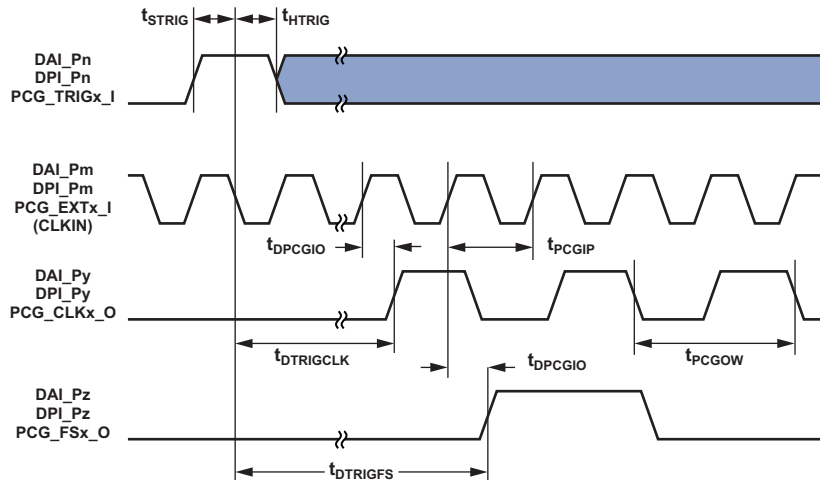

Figure 14. Precision Clock Generator (Direct Pin Routing)

Flags

The timing specifications provided below apply to the FLAG3-0 and DPI_P14-1 pins, and the serial peripheral interface (SPI). See [Table 8](#) for more information on flag use.

Table 20. Flags

Parameter	Min	Max	Unit
<i>Timing Requirement</i>			
t_{FIPW} FLAG3-0 IN Pulse Width	$2 \times t_{PCLK} + 3$		ns
<i>Switching Characteristic</i>			
t_{FOPW} FLAG3-0 OUT Pulse Width	$2 \times t_{PCLK} - 1.5$		ns

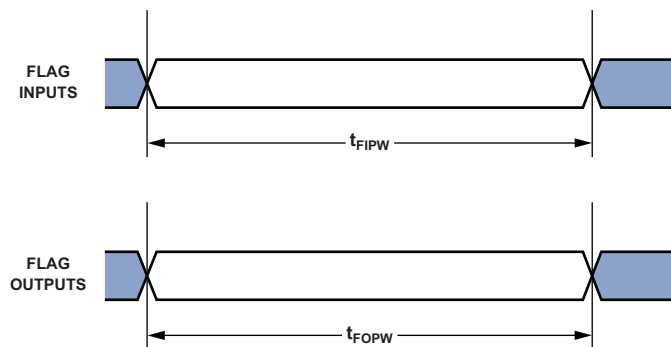

Figure 15. Flags

ADSP-21369

SDRAM Interface Timing (166 MHz SDCLK)

The 166 MHz access speed is for a single processor. When multiple ADSP-21369 processors are connected in a shared memory system, the access speed is 100 MHz.

Table 21. SDRAM Interface Timing¹

Parameter	366 MHz		350 MHz		All Other Speed Grades		Unit
	Min	Max	Min	Max	Min	Max	
<i>Timing Requirements</i>							
t_{SSDAT} DATA Setup Before SDCLK	500		500		500		ps
t_{HSDAT} DATA Hold After SDCLK	1.23		1.23		1.23		ns
<i>Switching Characteristics</i>							
t_{SDCLK} SDCLK Period	6.83		7.14		6.0		ns
t_{SDCLKH} SDCLK Width High	3		3		2.6		ns
t_{SDCLKL} SDCLK Width Low	3		3		2.6		ns
t_{DCAD} Command, ADDR, Data Delay After SDCLK ²		4.8		4.8		4.8	ns
t_{HCAD} Command, ADDR, Data Hold After SDCLK ²	1.2		1.2		1.2		ns
t_{DSDAT} Data Disable After SDCLK		5.3		5.3		5.3	ns
t_{ENSDAT} Data Enable After SDCLK	1.3		1.3		1.3		ns

¹ The processor needs to be programmed in $t_{SDCLK} = 2.5 \times t_{CCLK}$ mode when operated at 350 MHz, 366 MHz, and 400 MHz.

² Command pins include: SDCAS, SDRAS, SDWE, MSx, SDA10, SDCKE.

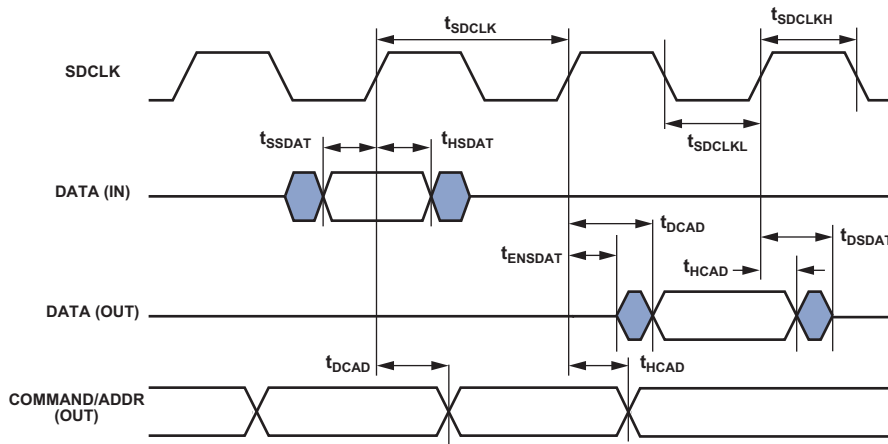

Figure 16. SDRAM Interface Timing

SDRAM Interface Enable/Disable Timing (166 MHz SDCLK)

Table 22. SDRAM Interface Enable/Disable Timing¹

Parameter	Min	Max	Unit
<i>Switching Characteristics</i>			
t_{DSDC} Command Disable After CLKIN Rise		$2 \times t_{PCLK} + 3$	ns
t_{ENSDC} Command Enable After CLKIN Rise	4.0		ns
t_{DSDCC} SDCLK Disable After CLKIN Rise		8.5	ns
t_{ENSDCC} SDCLK Enable After CLKIN Rise	3.8		ns
t_{DSDCA} Address Disable After CLKIN Rise		9.2	ns
t_{ENSDCA} Address Enable After CLKIN Rise	$2 \times t_{PCLK} - 4$	$4 \times t_{PCLK}$	ns

¹ For $f_{CLK} = 400$ MHz (SDCLK ratio = 1:2.5).

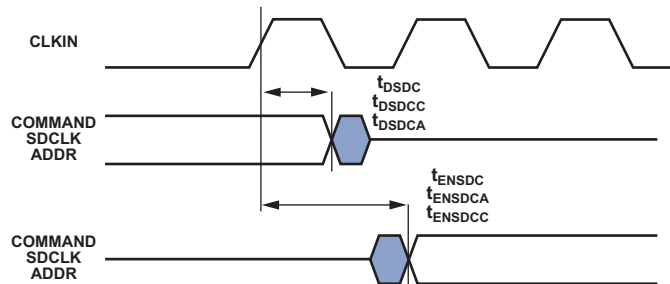

Figure 17. SDRAM Interface Enable/Disable Timing

Memory Read

Use these specifications for asynchronous interfacing to memories. These specifications apply when the processors are the bus master accessing external memory space in asynchronous access mode. Note that timing for ACK, DATA, \overline{RD} , \overline{WR} , and strobe timing parameters only apply to asynchronous access mode.

Table 23. Memory Read

Parameter	Min	Max	Unit
<i>Timing Requirements</i>			
t_{DAD} Address, Selects Delay to Data Valid ^{1, 2}		$W + t_{SDCLK} - 5.12$	ns
t_{DRLD} \overline{RD} Low to Data Valid ²		$W - 3.2$	ns
t_{SDS} Data Setup to \overline{RD} High	2.5		ns
t_{HDRH} Data Hold from \overline{RD} High ^{3, 4}	0		ns
t_{DAAK} ACK Delay from Address, Selects ^{1, 5}		$t_{SDCLK} - 9.5 + W$	ns
t_{DSAK} ACK Delay from \overline{RD} Low ⁵		$W - 7.0$	ns
<i>Switching Characteristics</i>			
t_{DRHA} Address Selects Hold After \overline{RD} High	$RH + 0.20$		ns
t_{DARL} Address Selects to \overline{RD} Low ¹	$t_{SDCLK} - 3.3$		ns
t_{RW} \overline{RD} Pulse Width	$W - 1.4$		ns
t_{RWR} \overline{RD} High to \overline{WR} , \overline{RD} Low	$HI + t_{SDCLK} - 0.8$		ns

$$W = (\text{number of wait states specified in AMICTLx register}) \times t_{SDCLK}$$

$$RHC = (\text{number of Read Hold Cycles specified in AMICTLx register}) \times t_{SDCLK}$$

Where PREDIS = 0

HI = RHC (if IC = 0): Read to Read from same bank

HI = RHC + t_{SDCLK} (if IC > 0): Read to Read from same bank

HI = RHC + IC: Read to Read from different bank

HI = RHC + Max (IC, $(4 \times t_{SDCLK})$): Read to Write from same or different bank

Where PREDIS = 1

HI = RHC + Max (IC, $(4 \times t_{SDCLK})$): Read to Write from same or different bank

HI = RHC + $(3 \times t_{SDCLK})$: Read to Read from same bank

HI = RHC + Max (IC, $(3 \times t_{SDCLK})$): Read to Read from different bank

$$IC = (\text{number of idle cycles specified in AMICTLx register}) \times t_{SDCLK}$$

$$H = (\text{number of hold cycles specified in AMICTLx register}) \times t_{SDCLK}$$

¹ The falling edge of \overline{MSx} is referenced.

² The maximum limit of timing requirement values for t_{DAD} and t_{DRLD} parameters are applicable for the case where AML_ACK is always high and when the ACK feature is not used.

³ Note that timing for ACK, DATA, \overline{RD} , \overline{WR} , and strobe timing parameters only apply to asynchronous access mode.

⁴ Data hold: User must meet t_{HDA} or t_{HDRH} in asynchronous access mode. See [Test Conditions](#) for the calculation of hold times given capacitive and dc loads.

⁵ ACK delay/setup: User must meet t_{DAAK} , or t_{DSAK} , for deassertion of ACK (low). For asynchronous assertion of ACK (high), user must meet t_{DAAK} or t_{DSAK} .

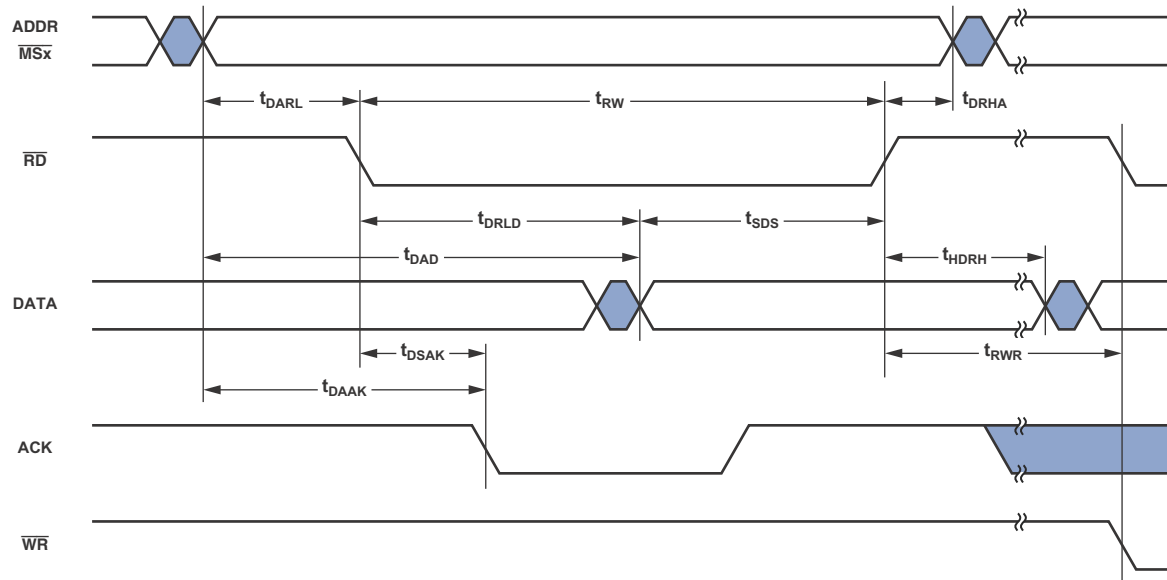

Figure 18. Memory Read

Memory Write

Use these specifications for asynchronous interfacing to memories. These specifications apply when the processor is the bus master, accessing external memory space in asynchronous

access mode. Note that timing for ACK, DATA, \overline{RD} , \overline{WR} , and strobe timing parameters only applies to asynchronous access mode.

Table 24. Memory Write

Parameter	Min	Max	Unit
<i>Timing Requirements</i>			
t_{DAAK} ACK Delay from Address, Selects ^{1,2}		$t_{SDCLK} - 9.7 + W$	ns
t_{DSAK} ACK Delay from \overline{WR} Low ^{1,3}		$W - 4.9$	ns
<i>Switching Characteristics</i>			
t_{DAWH} Address, Selects to \overline{WR} Deasserted ²	$t_{SDCLK} - 3.1 + W$		ns
t_{DAWL} Address, Selects to \overline{WR} Low ²	$t_{SDCLK} - 2.7$		ns
t_{WW} \overline{WR} Pulse Width	$W - 1.3$		ns
t_{DDWH} Data Setup Before \overline{WR} High	$t_{SDCLK} - 3.0 + W$		ns
t_{DWAH} Address Hold After \overline{WR} Deasserted	$H + 0.15$		ns
t_{DWHD} Data Hold After \overline{WR} Deasserted	$H + 0.02$		ns
t_{WWR} \overline{WR} High to \overline{WR} , \overline{RD} Low	$t_{SDCLK} - 1.5 + H$		ns
t_{DDWR} Data Disable Before \overline{RD} Low	$2t_{SDCLK} - 4.11$		ns
t_{WDE} Data Enabled to \overline{WR} Low	$t_{SDCLK} - 3.5$		ns

$W = (\text{number of wait states specified in AMICTLx register}) \times t_{SDCLK}$

$H = (\text{number of hold cycles specified in AMICTLx register}) \times t_{SDCLK}$

¹ ACK delay/setup: System must meet t_{DAAK} or t_{DSAK} for deassertion of ACK (low). For asynchronous assertion of ACK (high), user must meet t_{DAAK} or t_{DSAK} .

² The falling edge of \overline{MSx} is referenced.

³ Note that timing for ACK, DATA, \overline{RD} , \overline{WR} , and strobe timing parameters only applies to asynchronous access mode.

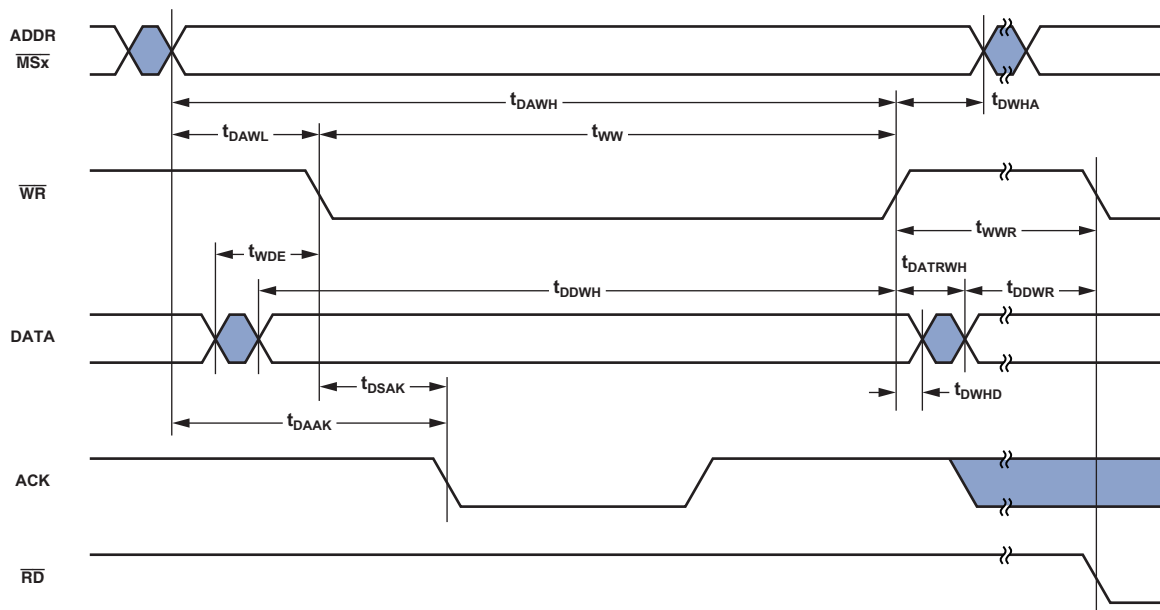

Figure 19. Memory Write

Asynchronous Memory Interface (AMI) Enable/Disable

Use these specifications for passing bus mastership between ADSP-21369 processors ($\overline{\text{BRx}}$).

Table 25. AMI Enable/Disable

Parameter	Min	Max	Unit
<i>Switching Characteristics</i>			
t_{ENAMIAc} Address/Control Enable After Clock Rise	4		ns
t_{ENAMID} Data Enable After Clock Rise	$t_{\text{SDCLK}} + 4$		ns
t_{DISAMIAc} Address/Control Disable After Clock Rise		8.7	ns
t_{DISAMID} Data Disable After Clock Rise		0	ns

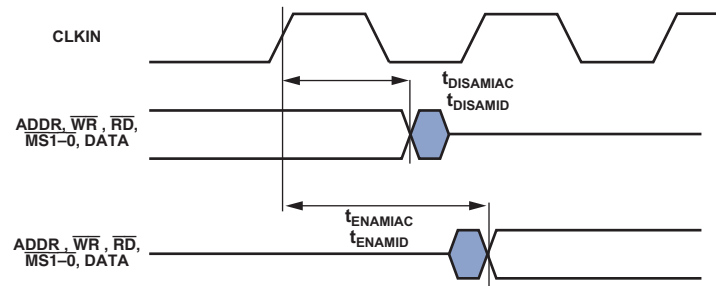

Figure 20. AMI Enable/Disable

ADSP-21369

Shared Memory Bus Request

Use these specifications for passing bus mastership between ADSP-21369 processors ($\overline{\text{BRx}}$).

Table 26. Multiprocessor Bus Request

Parameter	Min	Max	Unit
<i>Timing Requirements</i>			
t_{SBRI} $\overline{\text{BRx}}$, Setup Before CLKIN High	9		ns
t_{HBRI} $\overline{\text{BRx}}$, Hold After CLKIN High	0.5		ns
<i>Switching Characteristics</i>			
t_{DBRO} $\overline{\text{BRx}}$ Delay After CLKIN High		9	ns
t_{HBRO} $\overline{\text{BRx}}$ Hold After CLKIN High	1.0		ns

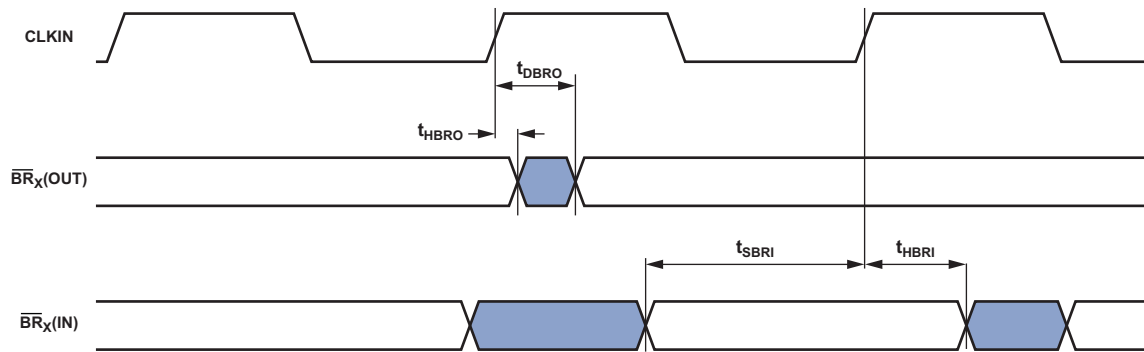

Figure 21. Shared Memory Bus Request

Serial Ports

To determine whether communication is possible between two devices at clock speed n , the following specifications must be confirmed: 1) frame sync delay and frame sync setup and hold, 2) data delay and data setup and hold, and 3) SCLK width.

Serial port signals SCLK, frame sync (FS), data channel A, and data channel B are routed to the DAI_P20–1 pins using the SRU. Therefore, the timing specifications provided in [Table 27](#) are valid at the DAI_P20–1 pins.

Table 27. Serial Ports—External Clock

Parameter	400 MHz 366 MHz 350 MHz		333 MHz		266 MHz		Unit		
	Min	Max	Min	Max	Min	Max			
<i>Timing Requirements</i>									
t_{SFSE}^1	FS Setup Before SCLK (Externally Generated FS in Either Transmit or Receive Mode)		2.5		2.5		2.5	ns	
t_{HFSE}^1	FS Hold After SCLK (Externally Generated FS in Either Transmit or Receive Mode)		2.5		2.5		2.5	ns	
t_{SDRE}^1	Receive Data Setup Before Receive SCLK		1.9		2.0		2.5	ns	
t_{HDRE}^1	Receive Data Hold After SCLK		2.5		2.5		2.5	ns	
t_{SCLKW}	SCLK Width		$(t_{PCLK} \times 4) \div 2 - 0.5$		$(t_{PCLK} \times 4) \div 2 - 0.5$		$(t_{PCLK} \times 4) \div 2 - 0.5$	ns	
t_{SCLK}	SCLK Period		$t_{PCLK} \times 4$		$t_{PCLK} \times 4$		$t_{PCLK} \times 4$	ns	
<i>Switching Characteristics</i>									
t_{DFSE}^2	FS Delay After SCLK (Internally Generated FS in Either Transmit or Receive Mode)			10.25		10.25		10.25	ns
t_{HOFSE}^2	FS Hold After SCLK (Internally Generated FS in Either Transmit or Receive Mode)		2		2		2	2	ns
t_{DDTE}^2	Transmit Data Delay After Transmit SCLK			7.8		9.6		9.8	ns
t_{HDTE}^2	Transmit Data Hold After Transmit SCLK		2		2		2	2	ns

¹ Referenced to sample edge.

² Referenced to drive edge.

ADSP-21369

Table 28. Serial Ports—Internal Clock

Parameter	Min	Max	Unit
<i>Timing Requirements</i>			
t_{SFSI}^1 FS Setup Before SCLK (Externally Generated FS in Either Transmit or Receive Mode)	7		ns
t_{HFSI}^1 FS Hold After SCLK (Externally Generated FS in Either Transmit or Receive Mode)	2.5		ns
t_{SDRI}^1 Receive Data Setup Before SCLK	7		ns
t_{HDRI}^1 Receive Data Hold After SCLK	2.5		ns
<i>Switching Characteristics</i>			
t_{DFSI}^2 FS Delay After SCLK (Internally Generated FS in Transmit Mode)		4	ns
t_{HOFSI}^2 FS Hold After SCLK (Internally Generated FS in Transmit Mode)	-1.0		ns
t_{DFSIR}^2 FS Delay After SCLK (Internally Generated FS in Receive Mode)		9.75	ns
$t_{HOF SIR}^2$ FS Hold After SCLK (Internally Generated FS in Receive Mode)	-1.0		ns
t_{DDTI}^2 Transmit Data Delay After SCLK		3.25	ns
t_{HDTI}^2 Transmit Data Hold After SCLK	-1.0		ns
t_{SCLKIW}^3 Transmit or Receive SCLK Width	$2 \times t_{PCLK} - 1.5$	$2 \times t_{PCLK} + 1.5$	ns

¹ Referenced to the sample edge.

² Referenced to drive edge.

³ Minimum SPORT divisor register value.

Table 29. Serial Ports—Enable and Three-State

Parameter	Min	Max	Unit
<i>Switching Characteristics</i>			
t_{DDTEN}^1 Data Enable from External Transmit SCLK	2		ns
t_{DDTTE}^1 Data Disable from External Transmit SCLK		10	ns
t_{DDTIN}^1 Data Enable from Internal Transmit SCLK	-1		ns

¹ Referenced to drive edge.

Table 30. Serial Ports—External Late Frame Sync

Parameter	Min	Max	Unit
<i>Switching Characteristics</i>			
$t_{DDTLFSE}^1$ Data Delay from Late External Transmit FS or External Receive FS with MCE = 1, MFD = 0		7.75	ns
$t_{DDTENFS}^1$ Data Enable for MCE = 1, MFD = 0	0.5		ns

¹ The $t_{DDTLFSE}$ and $t_{DDTENFS}$ parameters apply to left-justified sample pair as well as DSP serial mode, and MCE = 1, MFD = 0.

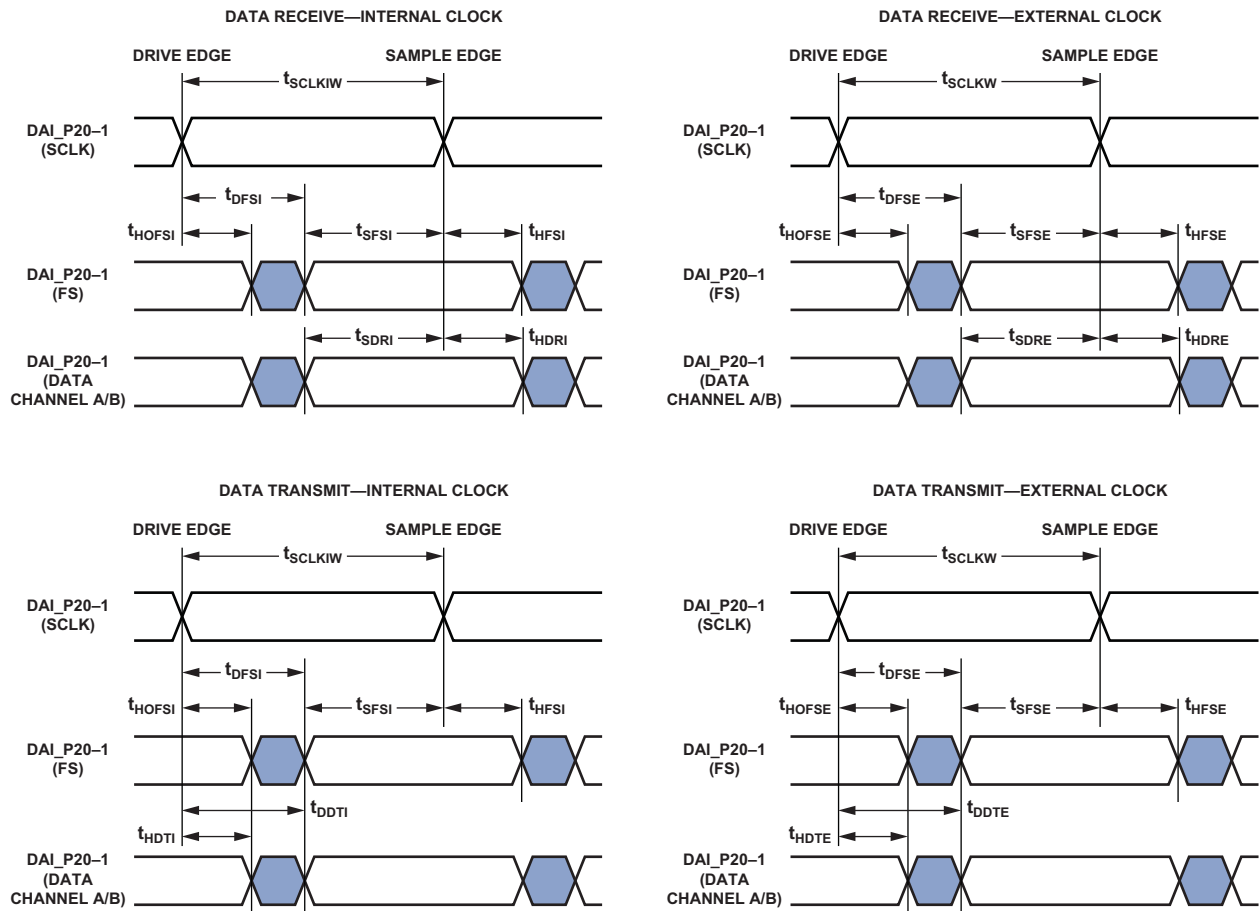

Figure 22. Serial Ports

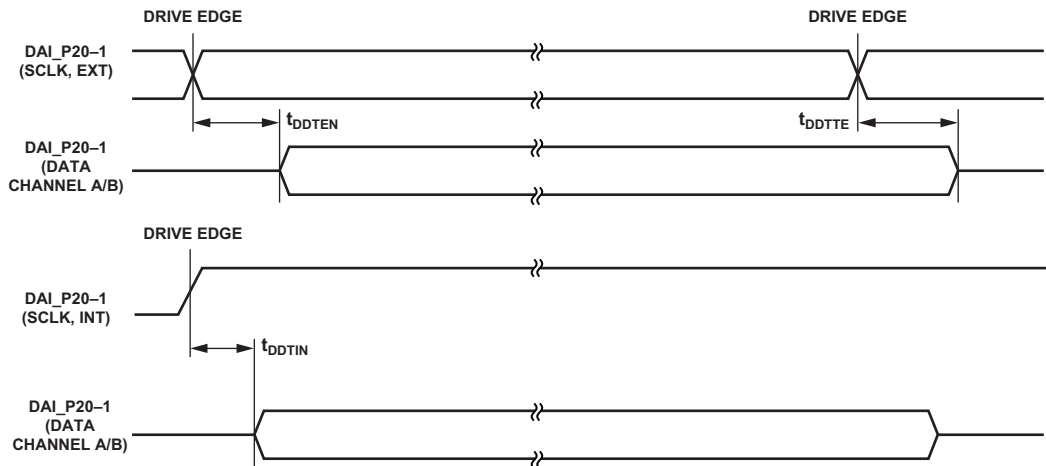

Figure 23. Enable and Three-State

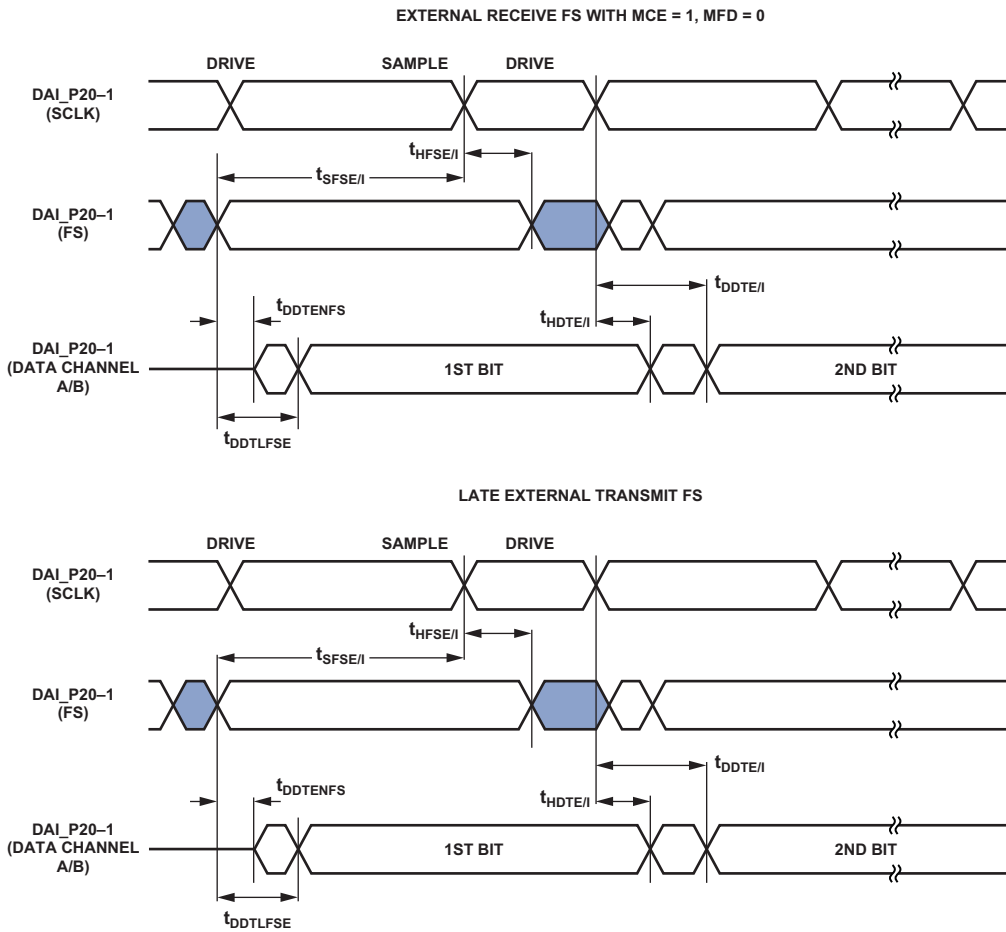

Figure 24. External Late Frame Sync¹

¹This figure reflects changes made to support left-justified sample pair mode.

Input Data Port

The timing requirements for the IDP are given in Table 31. IDP signals SCLK, frame sync (FS), and SDATA are routed to the DAI_P20-1 pins using the SRU. Therefore, the timing specifications provided in Table 31 are valid at the DAI_P20-1 pins.

Table 31. IDP

Parameter	Min	Max	Unit
<i>Timing Requirements</i>			
t_{SIFS}^1	FS Setup Before SCLK Rising Edge	4	ns
t_{SIHFS}^1	FS Hold After SCLK Rising Edge	2.5	ns
t_{SISD}^1	SDATA Setup Before SCLK Rising Edge	2.5	ns
t_{SIHD}^1	SDATA Hold After SCLK Rising Edge	2.5	ns
$t_{IDPCLKW}$	Clock Width	$(t_{PCLK} \times 4) \div 2 - 1$	ns
t_{IDPCLK}	Clock Period	$t_{PCLK} \times 4$	ns

¹ DATA, SCLK, FS can come from any of the DAI pins. SCLK and FS can also come via PCG or SPORTs. PCG's input can be either CLKIN or any of the DAI pins.

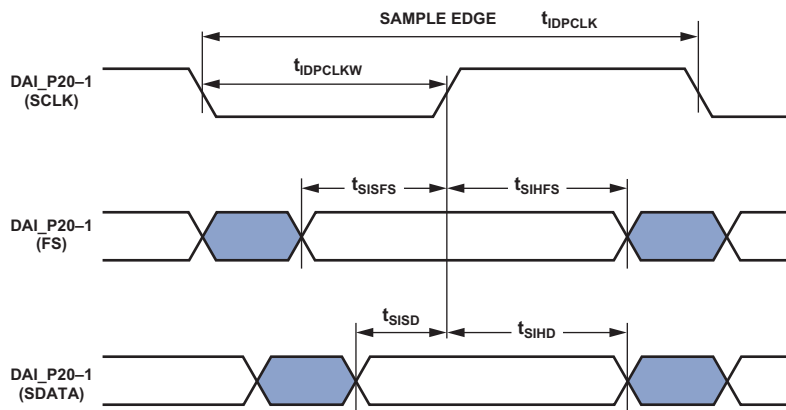

Figure 25. IDP Master Timing

ADSP-21369

Parallel Data Acquisition Port (PDAP)

The timing requirements for the PDAP are provided in [Table 32](#). PDAP is the parallel mode operation of Channel 0 of the input data port (IDP).

For details on the operation of the IDP, see the “Input Data Port” chapter of the [ADSP-2137x SHARC Processor Hardware Reference](#). Note that the 20 bits of external PDAP data can be provided through the external port DATA31–12 pins or the DAI pins.

Table 32. Parallel Data Acquisition Port (PDAP)

Parameter	Min	Max	Unit
<i>Timing Requirements</i>			
t_{SPHOLD}^1	PDAP_HOLD Setup Before PDAP_CLK Sample Edge	2.5	ns
t_{HPHOLD}^1	PDAP_HOLD Hold After PDAP_CLK Sample Edge	2.5	ns
t_{PDS}^1	PDAP_DAT Setup Before SCLK PDAP_CLK Sample Edge	3.85	ns
t_{PDHD}^1	PDAP_DAT Hold After SCLK PDAP_CLK Sample Edge	2.5	ns
t_{PDCLKW}	Clock Width	$(t_{PCLK} \times 4) \div 2 - 3$	ns
t_{PDCLK}	Clock Period	$t_{PCLK} \times 4$	ns
<i>Switching Characteristics</i>			
t_{PDHDD}	Delay of PDAP Strobe After Last PDAP_CLK Capture Edge for a Word	$2 \times t_{PCLK} + 3$	ns
t_{PDSTRB}	PDAP Strobe Pulse Width	$2 \times t_{PCLK} - 1$	ns

¹Data Source pins are DATA31–12, or DAI pins. Source pins for SCLK and FS are: 1) DATA11–10 pins, 2) DAI pins.

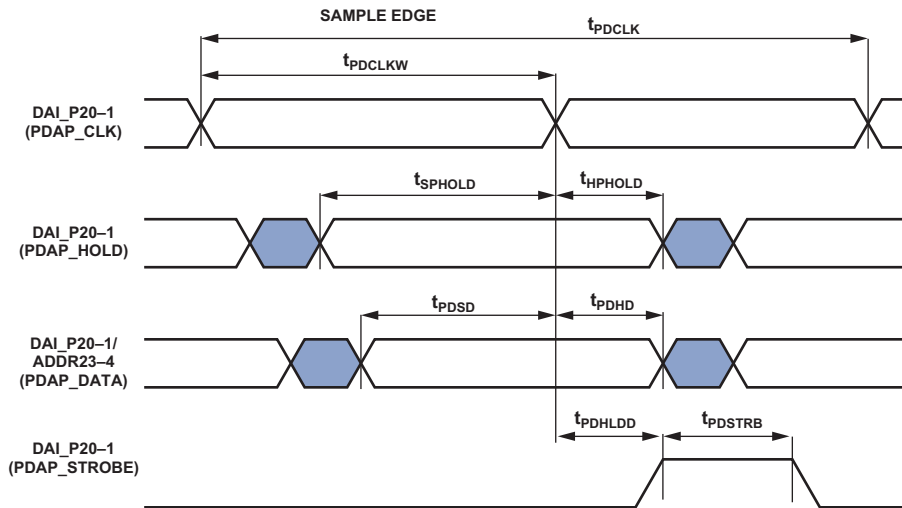

Figure 26. PDAP Timing

Pulse-Width Modulation Generators

Table 33. PWM Timing

Parameter		Min	Max	Unit
<i>Switching Characteristics</i>				
t_{PWW}	PWM Output Pulse Width	$t_{PCLK} - 2$	$(2^{16} - 2) \times t_{PCLK}$	ns
t_{PWMP}	PWM Output Period	$2 \times t_{PCLK} - 1.5$	$(2^{16} - 1) \times t_{PCLK}$	ns

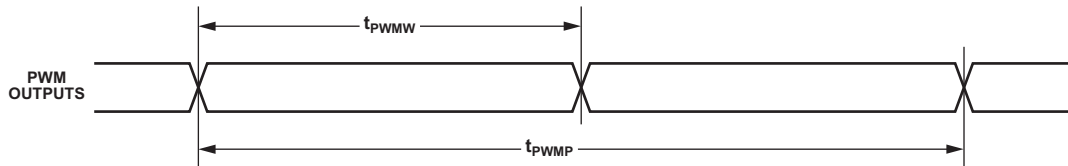

Figure 27. PWM Timing

Sample Rate Converter—Serial Input Port

The SRC input signals SCLK, frame sync (FS), and SDATA are routed from the DAI_P20–1 pins using the SRU. Therefore, the timing specifications provided in Table 34 are valid at the DAI_P20–1 pins.

Table 34. SRC, Serial Input Port

Parameter		Min	Max	Unit
<i>Timing Requirements</i>				
t_{SRCSFS}^1	FS Setup Before SCLK Rising Edge	4		ns
t_{SRCHFS}^1	FS Hold After SCLK Rising Edge	5.5		ns
$t_{SRCS D}^1$	SDATA Setup Before SCLK Rising Edge	4		ns
$t_{SRCH D}^1$	SDATA Hold After SCLK Rising Edge	5.5		ns
$t_{SRCCLKW}$	Clock Width	$(t_{PCLK} \times 4) \div 2 - 1$		ns
t_{SRCCLK}	Clock Period	$t_{PCLK} \times 4$		ns

¹ DATA, SCLK, FS can come from any of the DAI pins. SCLK and FS can also come via PCG or SPORTs. PCG's input can be either CLKIN or any of the DAI pins.

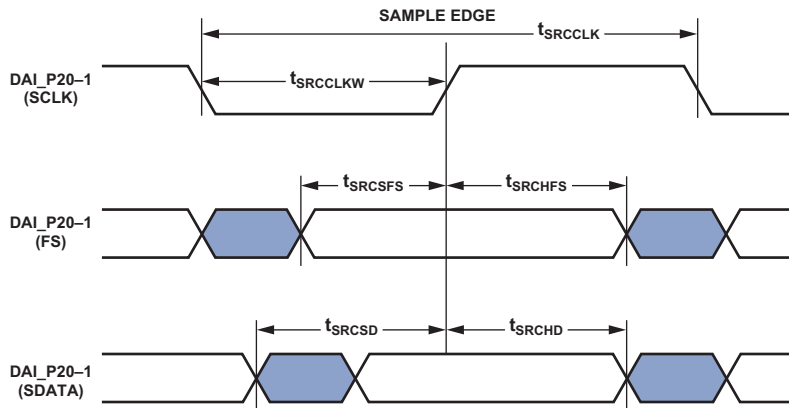

Figure 28. SRC Serial Input Port Timing

Sample Rate Converter—Serial Output Port

For the serial output port, the frame-sync is an input and it should meet setup and hold times with regard to SCLK on the output port. The serial data output, SDATA, has a hold time

and delay specification with regard to SCLK. Note that SCLK rising edge is the sampling edge and the falling edge is the drive edge.

Table 35. SRC, Serial Output Port

Parameter	Min	Max	Unit
<i>Timing Requirements</i>			
t_{SRCFS}^1 FS Setup Before SCLK Rising Edge	4		ns
t_{SRCHFS}^1 FS Hold After SCLK Rising Edge	5.5		ns
t_{SRCCLKW} Clock Width	$(t_{\text{PCLK}} \times 4) \div 2 - 1$		ns
t_{SRCCLK} Clock Period	$t_{\text{PCLK}} \times 4$		ns
<i>Switching Characteristics</i>			
t_{SRCTDD}^1 Transmit Data Delay After SCLK Falling Edge		9.9	ns
t_{SRCTDH}^1 Transmit Data Hold After SCLK Falling Edge	1		ns

¹ DATA, SCLK, and FS can come from any of the DAI pins. SCLK and FS can also come via PCG or SPORTs. PCG's input can be either CLKIN or any of the DAI pins.

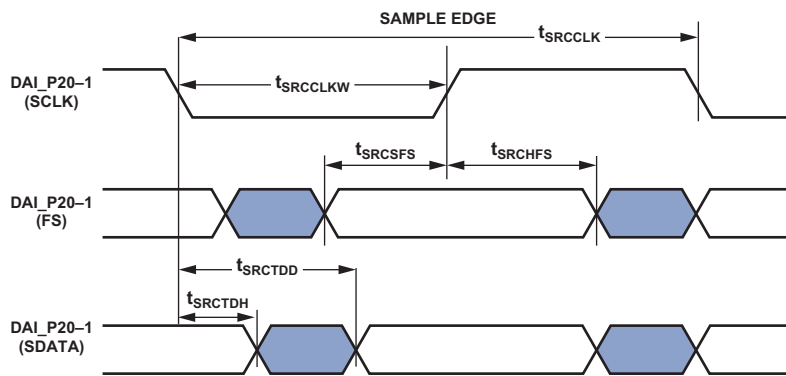

Figure 29. SRC Serial Output Port Timing

S/PDIF Transmitter

Serial data input to the S/PDIF transmitter can be formatted as left justified, I²S, or right justified with word widths of 16, 18, 20, or 24 bits. The following sections provide timing for the transmitter.

S/PDIF Transmitter—Serial Input Waveforms

Figure 30 shows the right-justified mode. LRCLK is high for the left channel and low for the right channel. Data is valid on the rising edge of SCLK. The MSB is delayed 12-bit clock periods (in 20-bit output mode) or 16-bit clock periods (in 16-bit output

mode) from an LRCLK transition, so that when there are 64 SCLK periods per LRCLK period, the LSB of the data is right-justified to the next LRCLK transition.

Figure 31 shows the default I²S-justified mode. LRCLK is low for the left channel and high for the right channel. Data is valid on the rising edge of SCLK. The MSB is left-justified to an LRCLK transition but with a single SCLK period delay.

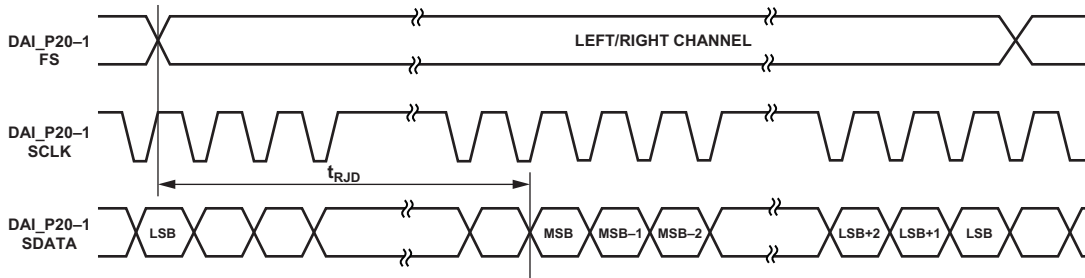

Figure 30. Right-Justified Mode

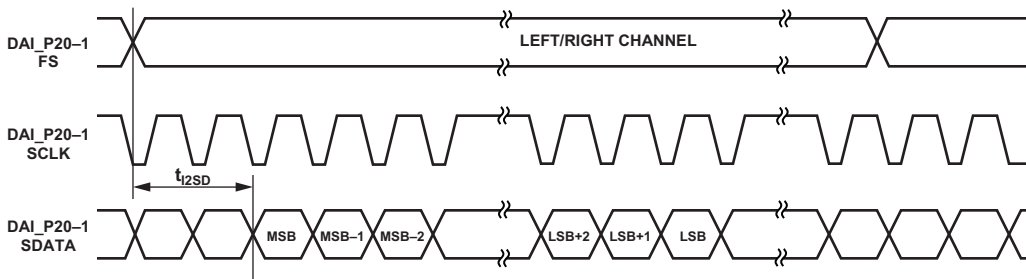

Figure 31. I²S-Justified Mode

Figure 32 shows the left-justified mode. LRCLK is high for the left channel and low for the right channel. Data is valid on the rising edge of SCLK. The MSB is left-justified to an LRCLK transition with no MSB delay.

S/PDIF Transmitter Input Data Timing

The timing requirements for the input port are given in Table 36. Input signals SCLK, frame sync (FS), and SDATA are routed to the DAI_P20-1 pins using the SRU. Therefore, the timing specifications provided in Table 36 are valid at the DAI_P20-1 pins.

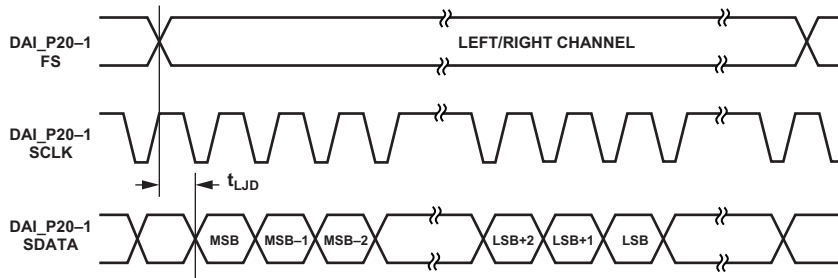

Figure 32. Left-Justified Mode

Table 36. S/PDIF Transmitter Input Data Timing

Parameter	Min	Max	Unit
<i>Timing Requirements</i>			
t_{SIFS}^1	FS Setup Before SCLK Rising Edge	3	ns
t_{SIHFS}^1	FS Hold After SCLK Rising Edge	3	ns
t_{SISD}^1	SDATA Setup Before SCLK Rising Edge	3	ns
t_{SIHD}^1	SDATA Hold After SCLK Rising Edge	3	ns
$t_{SISCLKW}$	Clock Width	36	ns
t_{SISCLK}	Clock Period	80	ns
$t_{SITXCLKW}$	Transmit Clock Width	9	ns
$t_{SITXCLK}$	Transmit Clock Period	20	ns

¹ DATA, SCLK, and FS can come from any of the DAI pins. SCLK and FS can also come via PCG or SPORTs. PCG's input can be either CLKIN or any of the DAI pins.

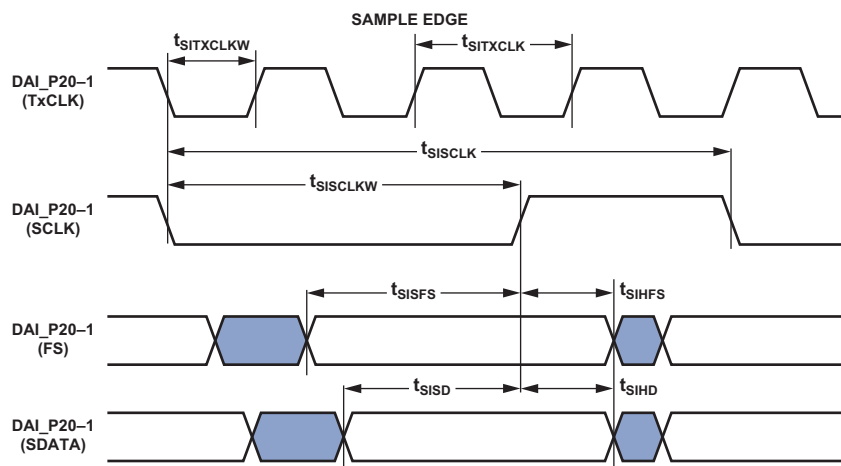

Figure 33. S/PDIF Transmitter Input Timing

ADSP-21369

Oversampling Clock (TxCLK) Switching Characteristics

The S/PDIF transmitter has an oversampling clock. This TxCLK input is divided down to generate the biphase clock.

Table 37. Oversampling Clock (TxCLK) Switching Characteristics

Parameter	Min	Max	Unit
TxCLK Frequency for TxCLK = 384 × FS		Oversampling Ratio × FS ≤ 1/t _{SITXCLK}	MHz
TxCLK Frequency for TxCLK = 256 × FS		49.2	MHz
Frame Rate (FS)		192.0	kHz

S/PDIF Receiver

The following section describes timing as it relates to the S/PDIF receiver.

Internal Digital PLL Mode

In the internal digital phase-locked loop mode the internal PLL (digital PLL) generates the 512 × FS clock.

Table 38. S/PDIF Receiver Internal Digital PLL Mode Timing

Parameter	Min	Max	Unit
<i>Switching Characteristics</i>			
t _{DFSI} LRCLK Delay After SCLK		5	ns
t _{HOFSI} LRCLK Hold After SCLK	-2		ns
t _{DDTI} Transmit Data Delay After SCLK		5	ns
t _{HDTI} Transmit Data Hold After SCLK	-2		ns
t _{SCLKIW} ¹ Transmit SCLK Width	40		ns

¹ SCLK frequency is 64 × FS where FS = the frequency of LRCLK.

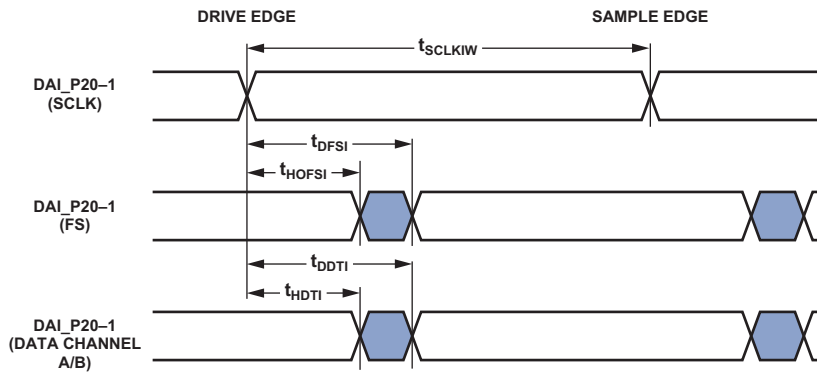

Figure 34. S/PDIF Receiver Internal Digital PLL Mode Timing

SPI Interface—Master

The processors contain two SPI ports. The primary has dedicated pins and the secondary is available through the DPI. The timing provided in [Table 39](#) and [Table 40](#) applies to both.

Table 39. SPI Interface Protocol—Master Switching and Timing Specifications

Parameter		Min	Max	Unit
<i>Timing Requirements</i>				
t_{SSPIDM}	Data Input Valid to SPICLK Edge (Data Input Setup Time)	8.2		ns
t_{HSPIDM}	SPICLK Last Sampling Edge to Data Input Not Valid	2		ns
<i>Switching Characteristics</i>				
$t_{SPICLKM}$	Serial Clock Cycle	$8 \times t_{PCLK} - 2$		ns
t_{SPICHM}	Serial Clock High Period	$4 \times t_{PCLK} - 2$		ns
t_{SPICLM}	Serial Clock Low Period	$4 \times t_{PCLK} - 2$		ns
$t_{DDSPIDM}$	SPICLK Edge to Data Out Valid (Data Out Delay Time)		2.5	ns
$t_{HDSPIDM}$	SPICLK Edge to Data Out Not Valid (Data Out Hold Time)	$4 \times t_{PCLK} - 2$		ns
t_{SDSCIM}	DPI Pin (SPI Device Select) Low to First SPICLK Edge	$4 \times t_{PCLK} - 2$		ns
t_{HDSM}	Last SPICLK Edge to DPI Pin (SPI Device Select) High	$4 \times t_{PCLK} - 2$		ns
t_{SPITDM}	Sequential Transfer Delay	$4 \times t_{PCLK} - 1$		ns

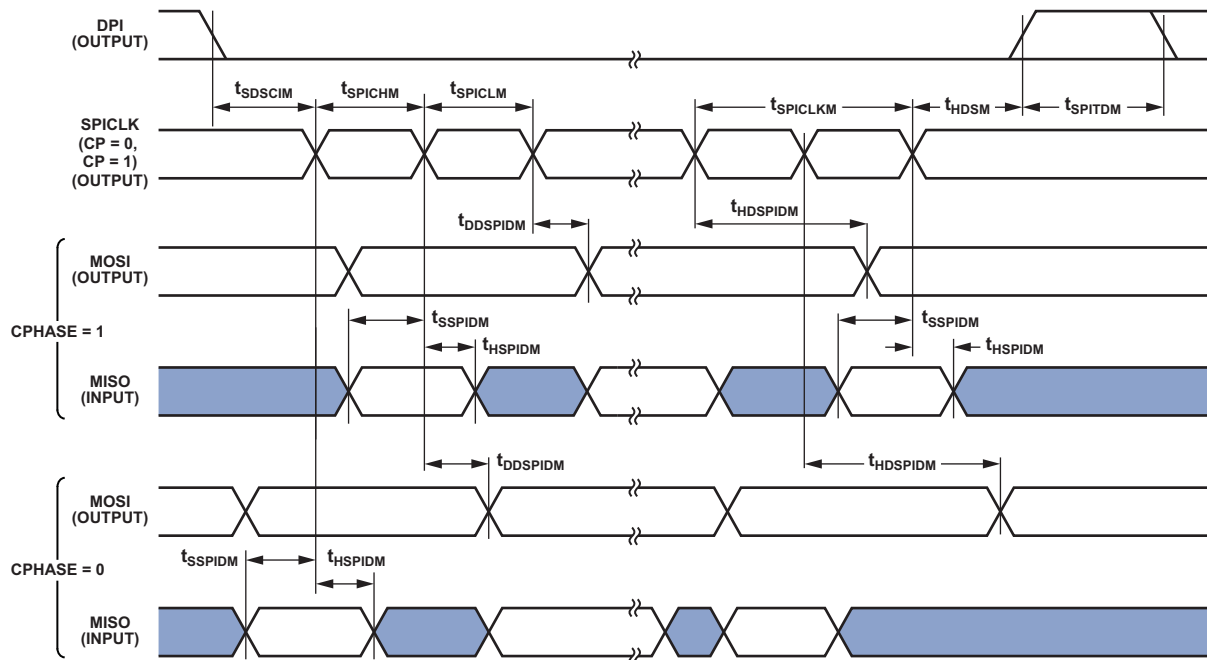

Figure 35. SPI Master Timing

SPI Interface—Slave

Table 40. SPI Interface Protocol—Slave Switching and Timing Specifications

Parameter		Min	Max	Unit
<i>Timing Requirements</i>				
$t_{SPICLKS}$	Serial Clock Cycle	$4 \times t_{PCLK} - 2$		ns
t_{SPICHS}	Serial Clock High Period	$2 \times t_{PCLK} - 2$		ns
t_{SPICLS}	Serial Clock Low Period	$2 \times t_{PCLK} - 2$		ns
t_{SDSCO}	\overline{SPIDS} Assertion to First SPICLK Edge, CPHASE = 0 or CPHASE = 1	$2 \times t_{PCLK}$		ns
t_{HDS}	Last SPICLK Edge to \overline{SPIDS} Not Asserted, CPHASE = 0	$2 \times t_{PCLK}$		ns
t_{SSPIDS}	Data Input Valid to SPICLK Edge (Data Input Setup Time)	2		ns
t_{HSPIDS}	SPICLK Last Sampling Edge to Data Input Not Valid	2		ns
t_{SDPPW}	\overline{SPIDS} Deassertion Pulse Width (CPHASE = 0)	$2 \times t_{PCLK}$		ns
<i>Switching Characteristics</i>				
t_{DSOE}	\overline{SPIDS} Assertion to Data Out Active	0	6.8	ns
t_{DSOE}^1	\overline{SPIDS} Assertion to Data Out Active (SPI2)	0	8	ns
t_{DSDHI}	\overline{SPIDS} Deassertion to Data High Impedance	0	6.8	ns
t_{DSDHI}^1	\overline{SPIDS} Deassertion to Data High Impedance (SPI2)	0	8.6	ns
$t_{DDSPIDS}$	SPICLK Edge to Data Out Valid (Data Out Delay Time)		9.5	ns
$t_{HDSPIDS}$	SPICLK Edge to Data Out Not Valid (Data Out Hold Time)	$2 \times t_{PCLK}$		ns
t_{DSOV}	\overline{SPIDS} Assertion to Data Out Valid (CPHASE = 0)		$5 \times t_{PCLK}$	ns

¹The timing for these parameters applies when the SPI is routed through the signal routing unit. For more information, see the [ADSP-2137x SHARC Processor Hardware Reference](#), “Serial Peripheral Interface Port” chapter.

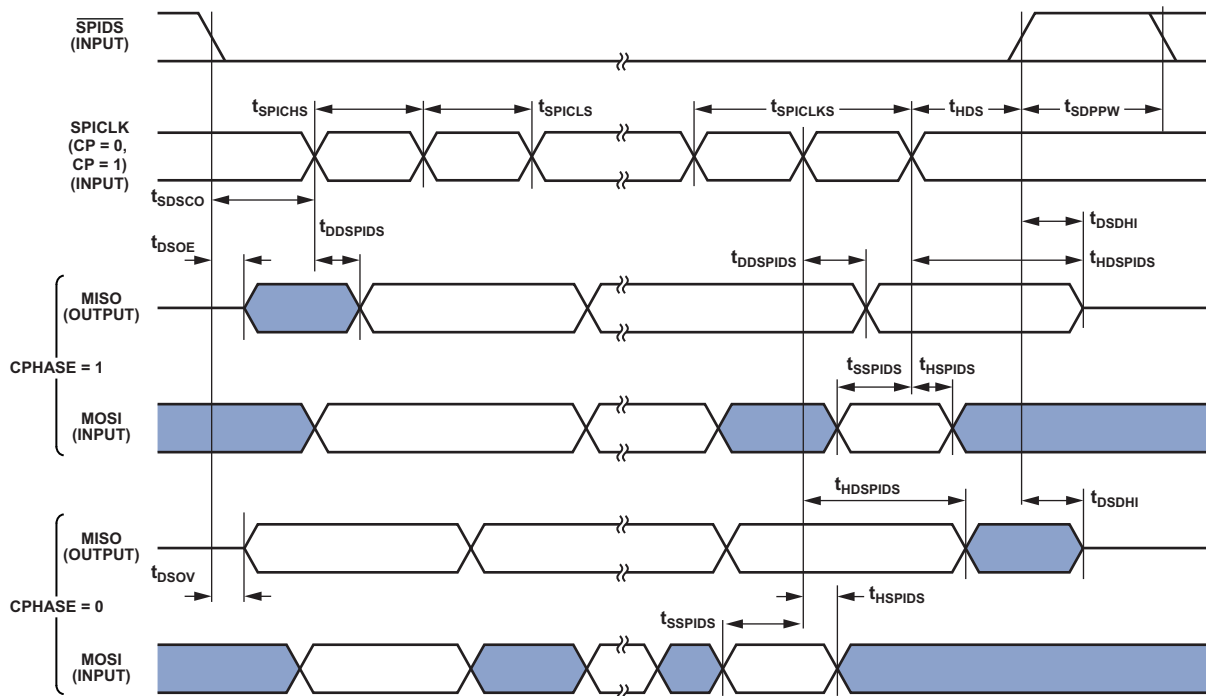

Figure 36. SPI Slave Timing

JTAG Test Access Port and Emulation

Table 41. JTAG Test Access Port and Emulation

Parameter		Min	Max	Unit
<i>Timing Requirements</i>				
t_{TCK}	TCK Period	t_{CK}		ns
t_{STAP}	TDI, TMS Setup Before TCK High	5		ns
t_{HTAP}	TDI, TMS Hold After TCK High	6		ns
t_{SSYS}^1	System Inputs Setup Before TCK High	7		ns
t_{HSYS}^1	System Inputs Hold After TCK High	18		ns
t_{TRSTW}	\overline{TRST} Pulse Width	$4t_{CK}$		ns
<i>Switching Characteristics</i>				
t_{DTDO}	TDO Delay from TCK Low		7	ns
t_{DSYS}^2	System Outputs Delay After TCK Low		$t_{CK} \div 2 + 7$	ns

¹ System Inputs = AD15-0, \overline{SPIDS} , CLK_CFG1-0, \overline{RESET} , BOOT_CFG1-0, MISO, MOSI, SPICLK, DAI_Px, FLAG3-0.

² System Outputs = MISO, MOSI, SPICLK, DAI_Px, AD15-0, \overline{RD} , \overline{WR} , FLAG3-0, EMU.

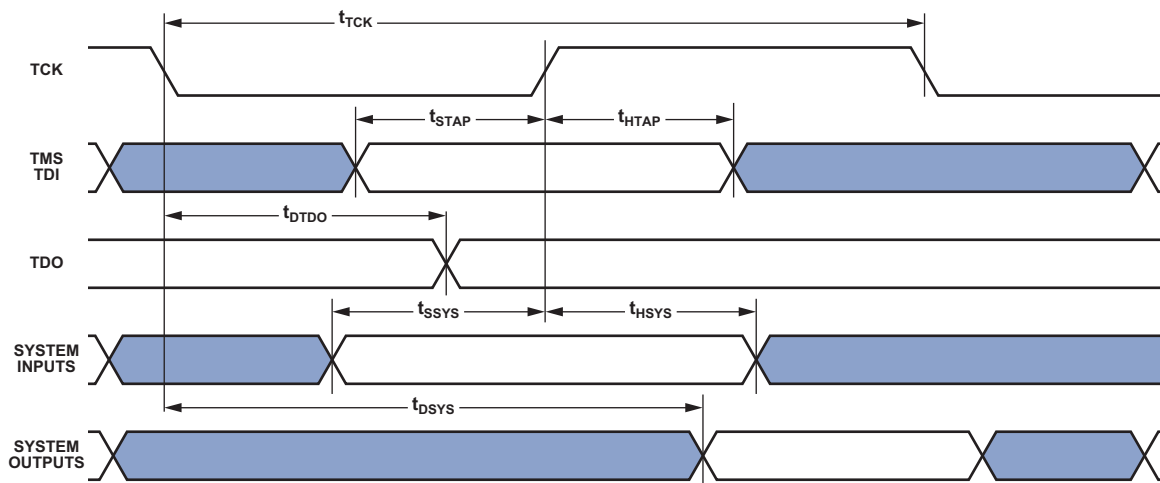

Figure 37. IEEE 1149.1 JTAG Test Access Port

OUTPUT DRIVE CURRENTS

Figure 38 shows typical I-V characteristics for the output drivers and Figure 39 shows typical I-V characteristics for the SDCLK output drivers. The curves represent the current drive capability of the output drivers as a function of output voltage.

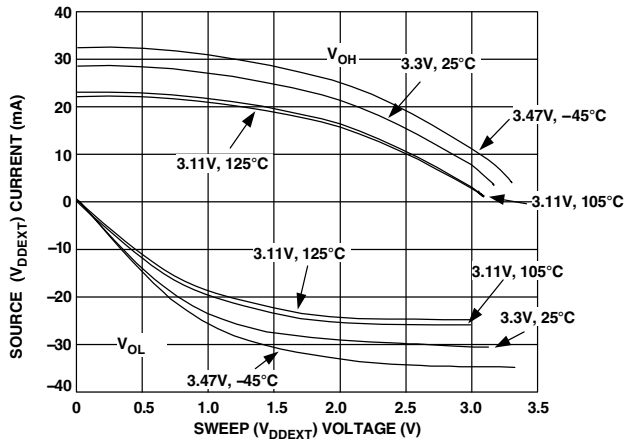

Figure 38. Typical Drive at Junction Temperature

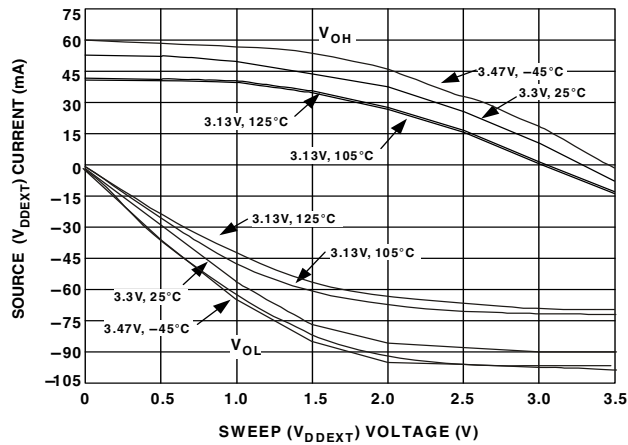

Figure 39. SDCLK1-0 Drive at Junction Temperature

TEST CONDITIONS

The AC signal specifications (timing parameters) appear in Table 13 through Table 41. These include output disable time, output enable time, and capacitive loading. The timing specifications for the SHARC apply for the voltage reference levels in Figure 40.

Timing is measured on signals when they cross the 1.5 V level as described in Figure 40. All delays (in nanoseconds) are measured between the point that the first signal reaches 1.5 V and the point that the second signal reaches 1.5 V.



Figure 40. Voltage Reference Levels for AC Measurements

CAPACITIVE LOADING

Output delays and holds are based on standard capacitive loads of an average of 6 pF on all pins (see Figure 41). Figure 46 and Figure 47 show graphically how output delays and holds vary with load capacitance. The graphs of Figure 42 through Figure 47 may not be linear outside the ranges shown for Typical Output Delay vs. Load Capacitance and Typical Output Rise Time (20% to 80%, V = Min) vs. Load Capacitance.

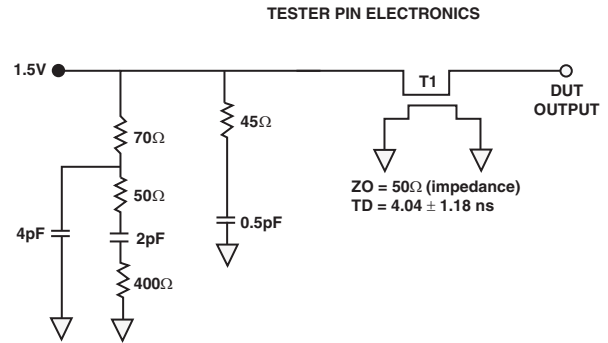

NOTES:
THE WORST CASE TRANSMISSION LINE DELAY IS SHOWN AND CAN BE USED FOR THE OUTPUT TIMING ANALYSIS TO REFLECT THE TRANSMISSION LINE EFFECT AND MUST BE CONSIDERED. THE TRANSMISSION LINE (TD), IS FOR LOAD ONLY AND DOES NOT AFFECT THE DATA SHEET TIMING SPECIFICATIONS.

ANALOG DEVICES RECOMMENDS USING THE IBIS MODEL TIMING FOR A GIVEN SYSTEM REQUIREMENT. IF NECESSARY, A SYSTEM MAY INCORPORATE EXTERNAL DRIVERS TO COMPENSATE FOR ANY TIMING DIFFERENCES.

Figure 41. Equivalent Device Loading for AC Measurements (Includes All Fixtures)

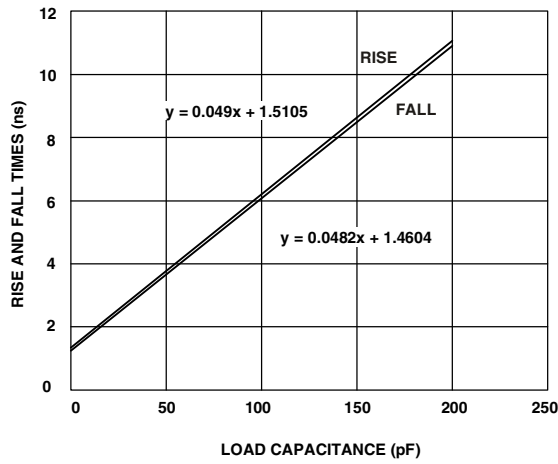

Figure 42. Typical Output Rise/Fall Time
(20% to 80%, $V_{DDEXT} = \text{Min}$)

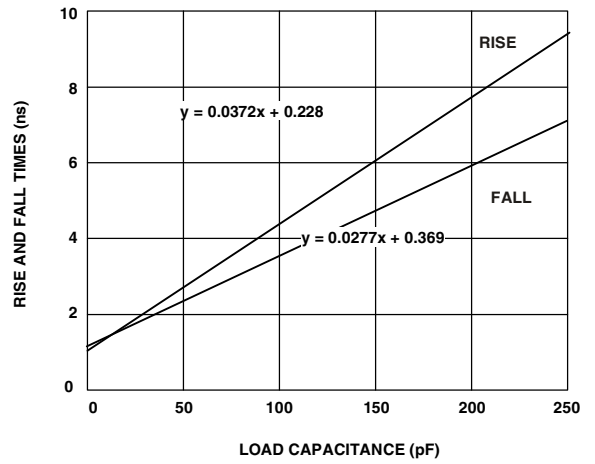

Figure 44. SDCLK Typical Output Rise/Fall Time
(20% to 80%, $V_{DDEXT} = \text{Min}$)

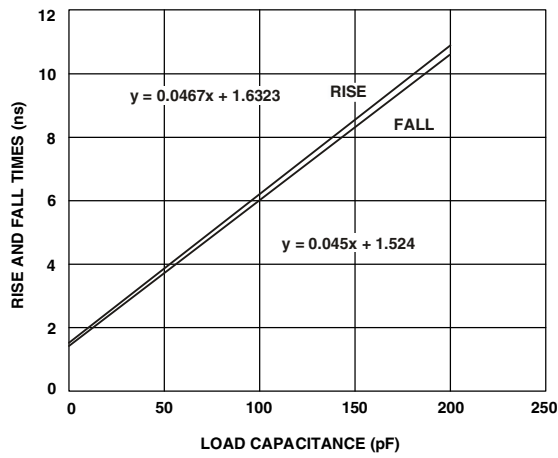

Figure 43. Typical Output Rise/Fall Time
(20% to 80%, $V_{DDEXT} = \text{Max}$)

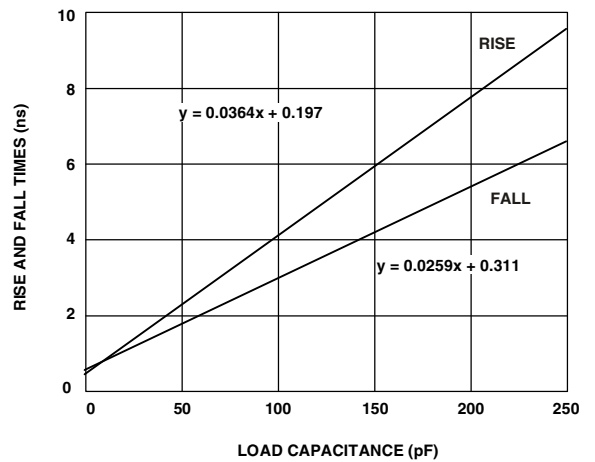

Figure 45. SDCLK Typical Output Rise/Fall Time
(20% to 80%, $V_{DDEXT} = \text{Max}$)

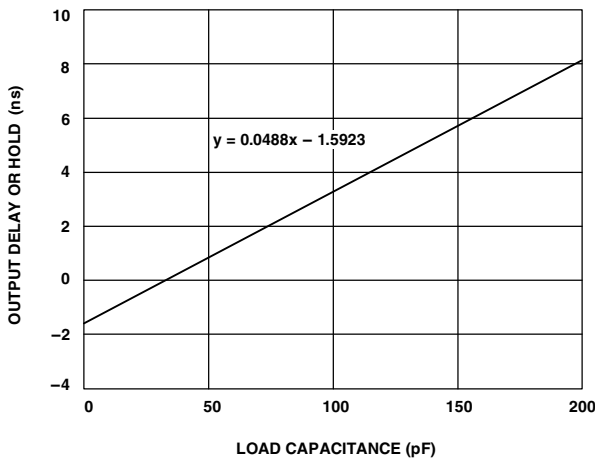

Figure 46. Typical Output Delay or Hold vs. Load Capacitance (at Junction Temperature)

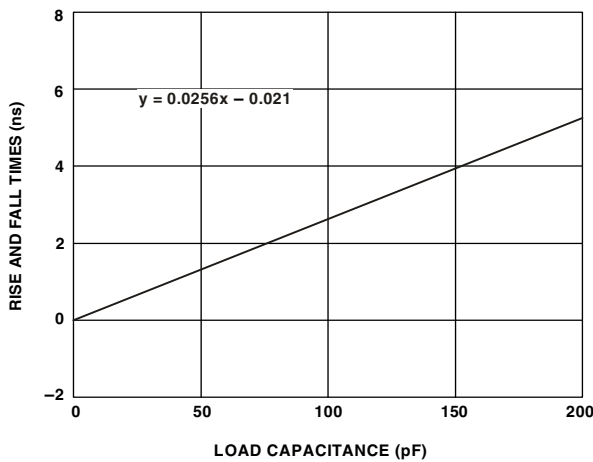

Figure 47. SDCLK Typical Output Delay or Hold vs. Load Capacitance (at Junction Temperature)

THERMAL CHARACTERISTICS

The processor is rated for performance over the temperature range specified in [Operating Conditions](#).

[Table 42](#) and [Table 43](#) airflow measurements comply with JEDEC standards JESD51-2 and JESD51-6 and the junction-to-board measurement complies with JESD51-8. The test board design complies with JEDEC standards JESD51-9 (BGA_ED) and JESD51-8 (LQFP_EP). The junction-to-case measurement complies with MIL-STD-883. All measurements use a 2S2P JEDEC test board.

The LQFP-EP package requires thermal trace squares and thermal vias, to an embedded ground plane, in the PCB. Refer to JEDEC standard JESD51-5 for more information.

To determine the junction temperature of the device while on the application PCB, use:

$$T_J = T_{TOP} + (\Psi_{JT} \times P_D)$$

where:

T_J = junction temperature (°C)

T_{TOP} = case temperature (°C) measured at the top center of the package

Ψ_{JT} = junction-to-top (of package) characterization parameter is the typical value from [Table 42](#) and [Table 43](#).

P_D = power dissipation (see Engineer-to-Engineer Note [EE-299](#))

Values of θ_{JA} are provided for package comparison and PCB design considerations. θ_{JA} can be used for a first-order approximation of T_J by the equation:

$$T_J = T_A + (\theta_{JA} \times P_D)$$

where:

T_A = ambient temperature (°C)

Values of θ_{JC} are provided for package comparison and PCB design considerations when an external heat sink is required. This is only applicable when a heat sink is used.

Values of θ_{JB} are provided for package comparison and PCB design considerations. The thermal characteristics values provided in [Table 42](#) and [Table 43](#) are modeled values at 2 W.

Table 42. Thermal Characteristics for 256-Ball BGA_ED

Parameter	Condition	Typical	Unit
θ_{JA}	Airflow = 0 m/s	12.5	°C/W
θ_{JMA}	Airflow = 1 m/s	10.6	°C/W
θ_{JMA}	Airflow = 2 m/s	9.9	°C/W
θ_{JC}		0.7	°C/W
θ_{JB}		5.3	°C/W
Ψ_{JT}	Airflow = 0 m/s	0.3	°C/W
Ψ_{JMT}	Airflow = 1 m/s	0.3	°C/W
Ψ_{JMT}	Airflow = 2 m/s	0.3	°C/W

Table 43. Thermal Characteristics for 208-Lead LQFP EPAD (with Exposed Pad Soldered to PCB)

Parameter	Condition	Typical	Unit
θ_{JA}	Airflow = 0 m/s	17.1	°C/W
θ_{JMA}	Airflow = 1 m/s	14.7	°C/W
θ_{JMA}	Airflow = 2 m/s	14.0	°C/W
θ_{JC}		9.6	°C/W
Ψ_{JT}	Airflow = 0 m/s	0.23	°C/W
Ψ_{JMT}	Airflow = 1 m/s	0.39	°C/W
Ψ_{JMT}	Airflow = 2 m/s	0.45	°C/W
Ψ_{JB}	Airflow = 0 m/s	11.5	°C/W
Ψ_{JMB}	Airflow = 1 m/s	11.2	°C/W
Ψ_{JMB}	Airflow = 2 m/s	11.0	°C/W

256-BALL BGA_ED PINOUT

The following table shows the pin names and their default function after reset (in parentheses) for the ADSP-21369 processor.

Table 44. 256-Ball BGA_ED Pin Assignment (Numerically by Ball Number)

Ball No.	Signal	Ball No.	Signal	Ball No.	Signal	Ball No.	Signal
A01	NC	B01	DAI_P05 (SD1A)	C01	DAI_P09 (SD2A)	D01	DAI_P10 (SD2B)
A02	TDI	B02	SDCLK1 ¹	C02	DAI_P07 (SCLK1)	D02	DAI_P06 (SD1B)
A03	TMS	B03	$\overline{\text{TRST}}$	C03	GND	D03	GND
A04	CLK_CFG0	B04	TCK	C04	V _{DDEXT}	D04	V _{DDEXT}
A05	CLK_CFG1	B05	BOOT_CFG0	C05	GND	D05	GND
A06	$\overline{\text{EMU}}$	B06	BOOT_CFG1	C06	GND	D06	V _{DDEXT}
A07	DAI_P04 (SFS0)	B07	TDO	C07	V _{DDINT}	D07	V _{DDINT}
A08	DAI_P01 (SD0A)	B08	DAI_P03 (SCLK0)	C08	GND	D08	GND
A09	DPI_P14 (TIMER1)	B09	DAI_P02 (SD0B)	C09	GND	D09	V _{DDEXT}
A10	DPI_P12 (TWI_CLK)	B10	DPI_P13 (TIMER0)	C10	V _{DDINT}	D10	V _{DDINT}
A11	DPI_P10 (UART0RX)	B11	DPI_P11 (TWI_DATA)	C11	GND	D11	GND
A12	DPI_P09 (UART0TX)	B12	DPI_P08 (SPIFLG3)	C12	GND	D12	V _{DDEXT}
A13	DPI_P07 (SPIFLG2)	B13	DPI_P05 (SPIFLG0)	C13	V _{DDINT}	D13	V _{DDINT}
A14	DPI_P06 (SPIFLG1)	B14	DPI_P04 (SPIDS)	C14	GND	D14	GND
A15	DPI_P03 (SPICLK)	B15	DPI_P01 (SPIMISO)	C15	GND	D15	V _{DDEXT}
A16	DPI_P02 (SPIMISO)	B16	$\overline{\text{RESET}}$	C16	V _{DDINT}	D16	GND
A17	$\overline{\text{RESETOUT}}$	B17	DATA30	C17	V _{DDINT}	D17	V _{DDEXT}
A18	DATA31	B18	DATA29	C18	V _{DDINT}	D18	GND
A19	NC	B19	DATA28	C19	DATA27	D19	DATA26
A20	NC	B20	NC	C20	RPBA	D20	DATA24
E01	DAI_P11 (SD3A)	F01	DAI_P14 (SFS3)	G01	DAI_P15 (SD4A)	H01	DAI_P17 (SD5A)
E02	DAI_P08 (SFS1)	F02	DAI_P12 (SD3B)	G02	DAI_P13 (SCLK3)	H02	DAI_P16 (SD4B)
E03	V _{DDINT}	F03	GND	G03	GND	H03	V _{DDINT}
E04	V _{DDINT}	F04	GND	G04	V _{DDEXT}	H04	V _{DDINT}
E17	GND	F17	V _{DDEXT}	G17	V _{DDINT}	H17	V _{DDEXT}
E18	GND	F18	GND	G18	V _{DDINT}	H18	GND
E19	DATA25	F19	ID2	G19	DATA22	H19	DATA19
E20	DATA23	F20	DATA21	G20	DATA20	H20	DATA18
J01	DAI_P19 (SCLK5)	K01	FLAG0	L01	FLAG2	M01	ACK
J02	DAI_P18 (SD5B)	K02	DAI_P20 (SFS5)	L02	FLAG1	M02	FLAG3
J03	GND	K03	GND	L03	V _{DDINT}	M03	GND
J04	GND	K04	V _{DDEXT}	L04	V _{DDINT}	M04	GND
J17	GND	K17	V _{DDINT}	L17	V _{DDINT}	M17	V _{DDEXT}
J18	GND	K18	V _{DDINT}	L18	V _{DDINT}	M18	GND
J19	ID1	K19	ID0	L19	DATA15	M19	DATA12
J20	DATA17	K20	DATA16	L20	DATA14	M20	DATA13

ADSP-21369

Table 44. 256-Ball BGA_ED Pin Assignment (Numerically by Ball Number) (Continued)

Ball No.	Signal	Ball No.	Signal	Ball No.	Signal	Ball No.	Signal
N01	\overline{RD}	P01	SDA10	R01	\overline{SDWE}	T01	SDCKE
N02	SDCLK0	P02	\overline{WR}	R02	\overline{SDRAS}	T02	\overline{SDCAS}
N03	GND	P03	V _{DDINT}	R03	GND	T03	GND
N04	V _{DDEXT}	P04	V _{DDINT}	R04	GND	T04	V _{DDEXT}
N17	GND	P17	V _{DDINT}	R17	V _{DDEXT}	T17	GND
N18	GND	P18	V _{DDINT}	R18	GND	T18	GND
N19	DATA11	P19	DATA8	R19	DATA6	T19	DATA5
N20	DATA10	P20	DATA9	R20	DATA7	T20	DATA4
U01	$\overline{MS0}$	V01	ADDR22	W01	GND	Y01	GND
U02	$\overline{MS1}$	V02	ADDR23	W02	ADDR21	Y02	NC
U03	V _{DDINT}	V03	V _{DDINT}	W03	ADDR19	Y03	NC
U04	GND	V04	GND	W04	ADDR20	Y04	ADDR18
U05	V _{DDEXT}	V05	GND	W05	ADDR17	Y05	$\overline{BR1}$
U06	GND	V06	GND	W06	ADDR16	Y06	$\overline{BR2}$
U07	V _{DDEXT}	V07	GND	W07	ADDR15	Y07	XTAL
U08	V _{DDINT}	V08	V _{DDINT}	W08	ADDR14	Y08	CLKIN
U09	V _{DDEXT}	V09	GND	W09	A _{VDD}	Y09	NC
U10	GND	V10	GND	W10	A _{VSS}	Y10	NC
U11	V _{DDEXT}	V11	GND	W11	ADDR13	Y11	$\overline{BR3}$
U12	V _{DDINT}	V12	V _{DDINT}	W12	ADDR12	Y12	$\overline{BR4}$
U13	V _{DDEXT}	V13	V _{DDEXT}	W13	ADDR10	Y13	ADDR11
U14	V _{DDEXT}	V14	GND	W14	ADDR8	Y14	ADDR9
U15	V _{DDINT}	V15	V _{DDINT}	W15	ADDR5	Y15	ADDR7
U16	V _{DDEXT}	V16	GND	W16	ADDR4	Y16	ADDR6
U17	V _{DDINT}	V17	GND	W17	ADDR1	Y17	ADDR3
U18	V _{DDINT}	V18	GND	W18	ADDR2	Y18	GND
U19	DATA0	V19	DATA1	W19	ADDR0	Y19	GND
U20	DATA2	V20	DATA3	W20	NC	Y20	NC

¹ The SDCLK1 signal is only available on the FCBGA package. SDCLK1 is not available on the LQFP_EP package.

Figure 48 shows the bottom view of the BGA_ED ball configuration. Figure 49 shows the top view of the BGA_ED ball configuration.

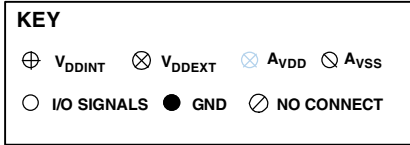
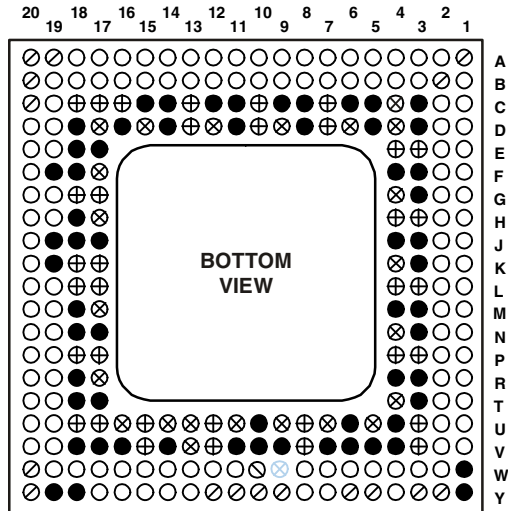

Figure 48. 256-Ball BGA_ED Ball Configuration (Bottom View)

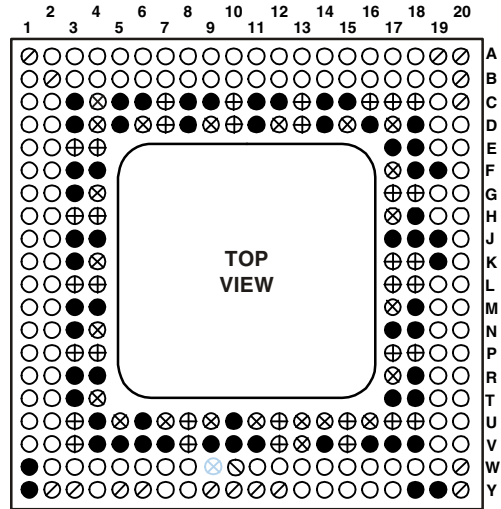

Figure 49. 256-Ball BGA_ED Ball Configuration (Top View)

ADSP-21369

208-LEAD LQFP_EP PINOUT

The following table shows the pin names and their default function after reset (in parentheses) for the ADSP-21369 processor.

Table 45. 208-Lead LQFP_EP Pin Assignment (Numerically by Lead Number)

Lead No.	Signal	Lead No.	Signal	Lead No.	Signal	Lead No.	Signal	Lead No.	Signal
1	V _{DDINT}	43	V _{DDINT}	85	V _{DDEXT}	127	V _{DDINT}	169	CLK_CFG0
2	DATA28	44	DATA4	86	GND	128	GND	170	BOOT_CFG0
3	DATA27	45	DATA5	87	V _{DDINT}	129	V _{DDEXT}	171	CLK_CFG1
4	GND	46	DATA2	88	ADDR14	130	DAI_P19 (SCLK5)	172	EMU
5	V _{DDEXT}	47	DATA3	89	GND	131	DAI_P18 (SD5B)	173	BOOT_CFG1
6	DATA26	48	DATA0	90	V _{DDEXT}	132	DAI_P17 (SD5A)	174	TDO
7	DATA25	49	DATA1	91	ADDR15	133	DAI_P16 (SD4B)	175	DAI_P04 (SFS0)
8	DATA24	50	V _{DDEXT}	92	ADDR16	134	DAI_P15 (SD4A)	176	DAI_P02 (SD0B)
9	DATA23	51	GND	93	ADDR17	135	DAI_P14 (SFS3)	177	DAI_P03 (SCLK0)
10	GND	52	V _{DDINT}	94	ADDR18	136	DAI_P13 (SCLK3)	178	DAI_P01 (SD0A)
11	V _{DDINT}	53	V _{DDINT}	95	GND	137	DAI_P12 (SD3B)	179	V _{DDEXT}
12	DATA22	54	GND	96	V _{DDEXT}	138	V _{DDINT}	180	GND
13	DATA21	55	V _{DDEXT}	97	ADDR19	139	V _{DDEXT}	181	V _{DDINT}
14	DATA20	56	ADDR0	98	ADDR20	140	GND	182	GND
15	V _{DDEXT}	57	ADDR2	99	ADDR21	141	V _{DDINT}	183	DPI_P14 (TIMER1)
16	GND	58	ADDR1	100	ADDR23	142	GND	184	DPI_P13 (TIMER0)
17	DATA19	59	ADDR4	101	ADDR22	143	DAI_P11 (SD3A)	185	DPI_P12 (TWI_CLK)
18	DATA18	60	ADDR3	102	$\overline{MS1}$	144	DAI_P10 (SD2B)	186	DPI_P11 (TWI_DATA)
19	V _{DDINT}	61	ADDR5	103	$\overline{MS0}$	145	DAI_P08 (SFS1)	187	DPI_P10 (UARTORX)
20	GND	62	GND	104	V _{DDINT}	146	DAI_P09 (SD2A)	188	DPI_P09 (UARTOTX)
21	DATA17	63	V _{DDINT}	105	V _{DDINT}	147	DAI_P06 (SD1B)	189	DPI_P08 (SPIFLG3)
22	V _{DDINT}	64	GND	106	GND	148	DAI_P07 (SCLK1)	190	DPI_P07 (SPIFLG2)
23	GND	65	V _{DDEXT}	107	V _{DDEXT}	149	DAI_P05 (SD1A)	191	V _{DDEXT}
24	V _{DDINT}	66	ADDR6	108	\overline{SDCAS}	150	V _{DDEXT}	192	GND
25	GND	67	ADDR7	109	\overline{SDRAS}	151	GND	193	V _{DDINT}
26	DATA16	68	ADDR8	110	SDCKE	152	V _{DDINT}	194	GND
27	DATA15	69	ADDR9	111	\overline{SDWE}	153	GND	195	DPI_P06 (SPIFLG1)
28	DATA14	70	ADDR10	112	\overline{WR}	154	V _{DDINT}	196	DPI_P05 (SPIFLG0)
29	DATA13	71	GND	113	SDA10	155	GND	197	DPI_P04 (SPIDS)
30	DATA12	72	V _{DDINT}	114	GND	156	V _{DDINT}	198	DPI_P03 (SPICLK)
31	V _{DDEXT}	73	GND	115	V _{DDEXT}	157	V _{DDINT}	199	DPI_P01 (SPIMOSI)
32	GND	74	V _{DDEXT}	116	SDCLK0	158	V _{DDINT}	200	DPI_P02 (SPIMISO)
33	V _{DDINT}	75	ADDR11	117	GND	159	GND	201	$\overline{RESETOUT}$
34	GND	76	ADDR12	118	V _{DDINT}	160	V _{DDINT}	202	\overline{RESET}
35	DATA11	77	ADDR13	119	\overline{RD}	161	V _{DDINT}	203	V _{DDEXT}
36	DATA10	78	GND	120	ACK	162	V _{DDINT}	204	GND
37	DATA9	79	V _{DDINT}	121	FLAG3	163	TDI	205	DATA30
38	DATA8	80	A _{VSS}	122	FLAG2	164	\overline{TRST}	206	DATA31
39	DATA7	81	A _{VDD}	123	FLAG1	165	TCK	207	DATA29

Table 45. 208-Lead LQFP_EP Pin Assignment (Numerically by Lead Number) (Continued)

Lead No.	Signal	Lead No.	Signal	Lead No.	Signal	Lead No.	Signal	Lead No.	Signal
40	DATA6	82	GND	124	FLAG0	166	GND	208	V _{DDINT}
41	V _{DDEXT}	83	CLKIN	125	DAI_P20 (SFS5)	167	V _{DDINT}		
42	GND	84	XTAL	126	GND	168	TMS		

ADSP-21369

PACKAGE DIMENSIONS

The ADSP-21369 processor is available in 256-ball RoHS compliant and leaded BGA_ED, and 208-lead RoHS compliant LQFP_EP packages.

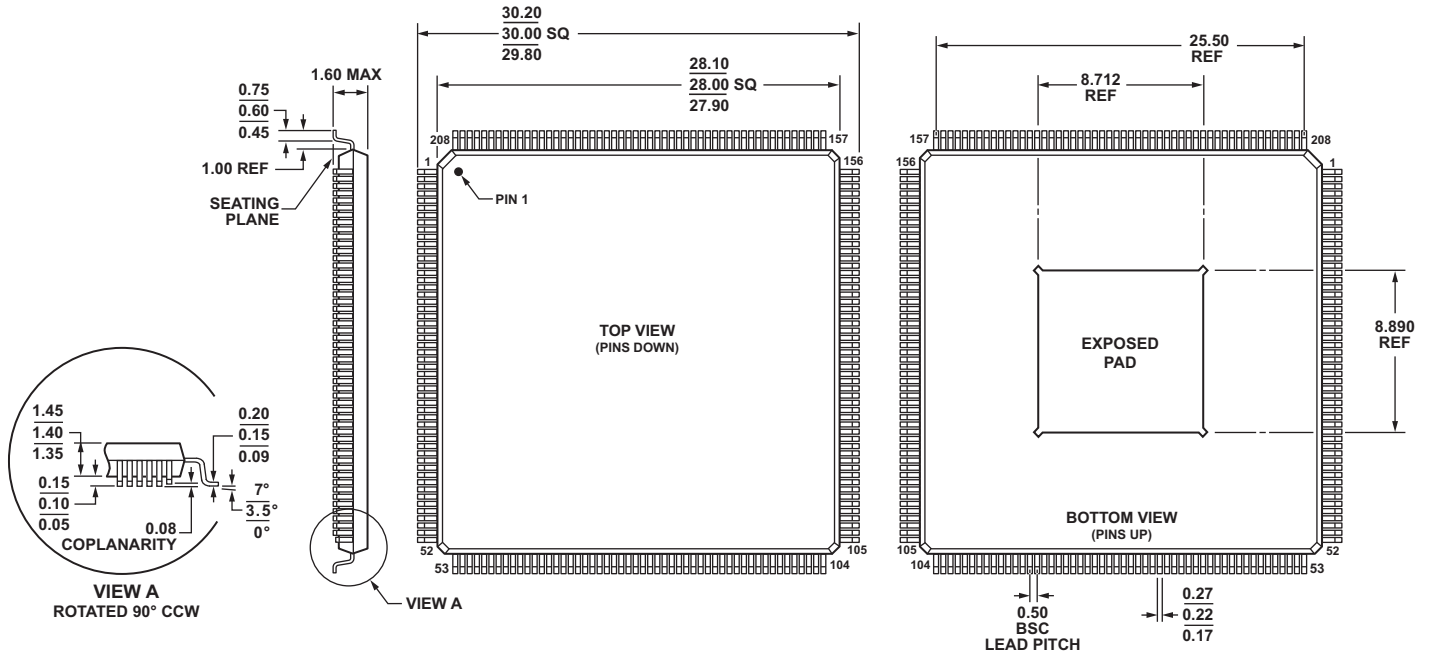

COMPLIANT TO JEDEC STANDARDS MS-026-BJB-HD

NOTE:
 THE EXPOSED PAD IS REQUIRED TO BE ELECTRICALLY AND THERMALLY CONNECTED TO VSS. THIS SHOULD BE IMPLEMENTED BY SOLDERING THE EXPOSED PAD TO A VSS PCB LAND THAT IS THE SAME SIZE AS THE EXPOSED PAD. THE VSS PCB LAND SHOULD BE ROBUSTLY CONNECTED TO THE VSS PLANE IN THE PCB WITH AN ARRAY OF THERMAL VIAS FOR BEST PERFORMANCE.

Figure 50. 208-Lead Low Profile Quad Flat Package, Exposed Pad [LQFP_EP]
 (SW-208-1)
 Dimensions shown in millimeters

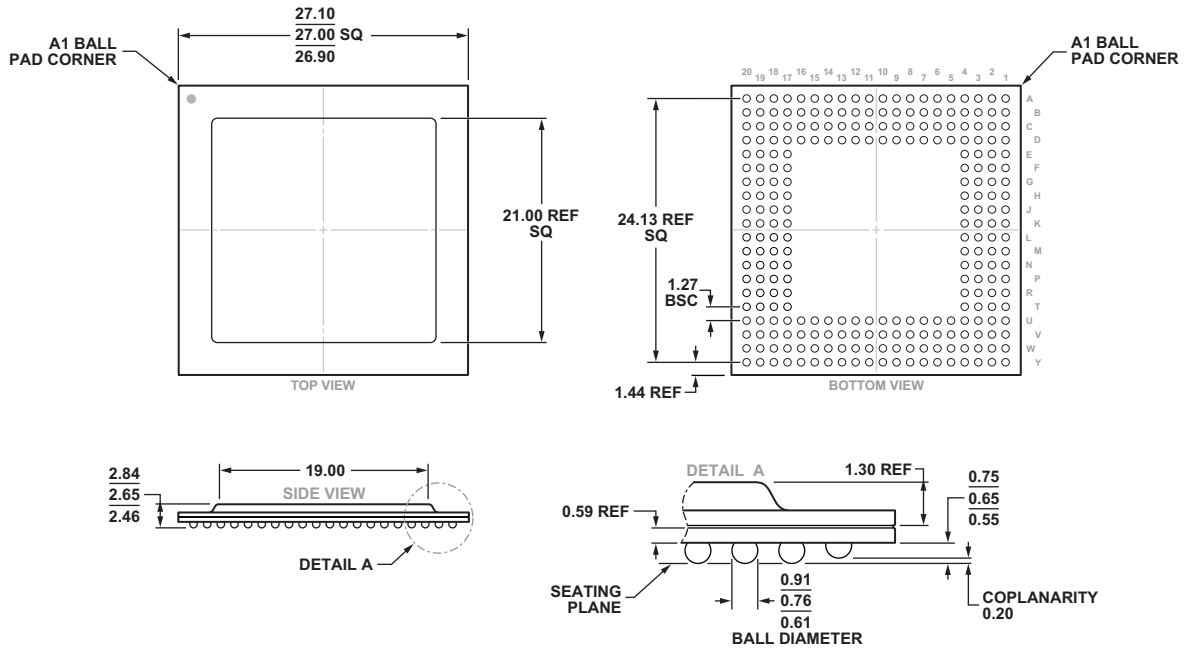

Figure 51. 256-Ball Ball Grid Array, Thermally Enhanced [BGA_ED]
(BP-256-2)

Dimension shown in millimeters

SURFACE-MOUNT DESIGN

Table 46 is provided as an aide to PCB design. For industry-standard design recommendations, refer to IPC-7351, *Generic Requirements for Surface-Mount Design and Land Pattern Standard*.

Table 46. BGA_ED Data for Use with Surface-Mount Design

Package	Ball Attach Type	Solder Mask Opening	Ball Pad Size
256-Lead Ball Grid Array BGA_ED (BP-256-2)	Solder Mask Defined (SMD)	0.63 mm	0.73 mm

ADSP-21369

ORDERING GUIDE



Model	Notes	Temperature Range ¹	Instruction Rate	On-Chip SRAM	ROM	Package Description	Package Option
ADSP-21369KBPZ-2A	²	0°C to +70°C	333 MHz	2M bit	6M bit	256-Ball BGA_ED	BP-256-2
ADSP-21369BBPZ-2A	²	-40°C to +85°C	333 MHz	2M bit	6M bit	256-Ball BGA_ED	BP-256-2
ADSP-21369KBPZ-3A	²	0°C to +70°C	400 MHz	2M bit	6M bit	256-Ball BGA_ED	BP-256-2
ADSP-21369KSWZ-1A	²	0°C to +70°C	266 MHz	2M bit	6M bit	208-Lead LQFP_EP	SW-208-1
ADSP-21369KSWZ-2A	²	0°C to +70°C	333 MHz	2M bit	6M bit	208-Lead LQFP_EP	SW-208-1
ADSP-21369KSWZ-4A	²	0°C to +70°C	350 MHz	2M bit	6M bit	208-Lead LQFP_EP	SW-208-1
ADSP-21369KSWZ-5A	²	0°C to +70°C	366 MHz	2M bit	6M bit	208-Lead LQFP_EP	SW-208-1
ADSP-21369KSWZ-6A	²	0°C to +70°C	400 MHz	2M bit	6M bit	208-Lead LQFP_EP	SW-208-1
ADSP-21369BSWZ-1A	²	-40°C to +85°C	266 MHz	2M bit	6M bit	208-Lead LQFP_EP	SW-208-1
ADSP-21369BSWZ-2A	²	-40°C to +85°C	333 MHz	2M bit	6M bit	208-Lead LQFP_EP	SW-208-1

¹ Referenced temperature is ambient temperature.

² Z = RoHS Compliant Part.

Looking for pricing, stock, or lifecycle information?

Click below to explore more details on WIN SOURCE:

-  [View ADSP-21369KBPZ-3A on WIN SOURCE](#)
-  [Analog Devices Inc. Information](#)

Optimize Your Supply Chain with WIN SOURCE Solutions

-  Global Sourcing Solution
-  Obsolete Management
-  Cost Control Management
-  Shortage Management
-  Alternative Solution
-  Excess Inventory Management