

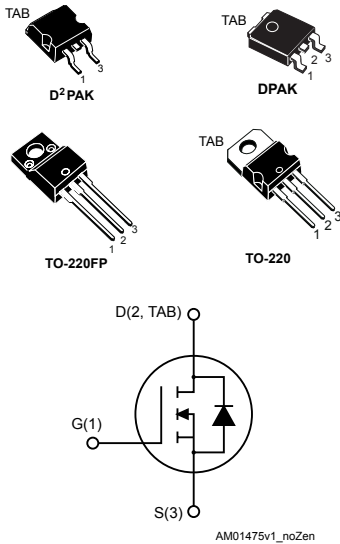

# THE DATASHEET OF STB11N65M5



## N-channel 650 V, 0.43 $\Omega$ typ., 9 A MDmesh™ M5 Power MOSFETs in a DPAK, D<sup>2</sup>PAK, TO-220FP and TO-220 packages



### Features

Order code	$V_{DS}$ @ $T_{jmax.}$	$R_{DS(on)max.}$	$I_D$
STB11N65M5	710 V	0.48 $\Omega$	9 A
STD11N65M5			
STF11N65M5			
STP11N65M5			

- Extremely low  $R_{DS(on)}$
- Low gate charge and input capacitance
- Excellent switching performance
- 100% avalanche tested

### Applications

- Switching applications

### Description

These devices are N-channel Power MOSFET based on the MDmesh™ M5 innovative vertical process technology combined with the well-known PowerMESH™ horizontal layout. The resulting products offer extremely low on-resistance, making them particularly suitable for applications requiring high power and superior efficiency.

Product status
<a href="#">STB11N65M5</a>
<a href="#">STD11N65M5</a>
<a href="#">STF11N65M5</a>
<a href="#">STP11N65M5</a>

# 1 Electrical ratings

**Table 1. Absolute maximum ratings**

Symbol	Parameter	Value		Unit
		D <sup>2</sup> PAK DPAK TO-220	TO-220FP	
V <sub>GS</sub>	Gate-source voltage	±25		V
I <sub>D</sub>	Drain current (continuous) at T <sub>C</sub> = 25 °C	9	9 <sup>(1)</sup>	A
I <sub>D</sub>	Drain current (continuous) at T <sub>C</sub> = 100 °C	5.6	5.6 <sup>(1)</sup>	A
I <sub>DM</sub> <sup>(2)</sup>	Drain current (pulsed)	36	36 <sup>(1)</sup>	A
P <sub>TOT</sub>	Total dissipation at T <sub>C</sub> = 25 °C	85	25	W
dv/dt <sup>(3)</sup>	Peak diode recovery voltage slope	15		V/ns
V <sub>ISO</sub>	Insulation withstand voltage (RMS) from all three leads to external heat sink (t = 1 s; T <sub>C</sub> = 25 °C)		2500	V
T <sub>J</sub>	Operating junction temperature range	-55 to 150		°C
T <sub>stg</sub>	Storage temperature range			

- Limited by maximum junction temperature.
- Pulse width limited by safe operating area.
- $I_{SD} \leq 9\text{ A}$ ,  $di/dt \leq 400\text{ A}/\mu\text{s}$ ;  $V_{DS\ peak} < V_{(BR)DSS}$ ,  $V_{DD} = 400\text{ V}$ .

**Table 2. Thermal data**

Symbol	Parameter	Value				Unit
		D <sup>2</sup> PAK	DPAK	TO-220FP	TO-220	
R <sub>thj-case</sub>	Thermal resistance junction-case	1.47		5.0	1.47	°C/W
R <sub>thj-amb</sub>	Thermal resistance junction-ambient			62.5		°C/W
R <sub>thj-pcb</sub> <sup>(1)</sup>	Thermal resistance junction-pcb	30	50			°C/W

- When mounted on 1 inch<sup>2</sup> FR-4, 2 Oz copper board.

**Table 3. Avalanche characteristics**

Symbol	Parameter	Value	Unit
I <sub>AR</sub>	Avalanche current, repetitive or not-repetitive (pulse width limited by T <sub>J</sub> Max)	2	A
E <sub>AS</sub>	Single pulse avalanche energy (starting T <sub>J</sub> = 25 °C, I <sub>D</sub> = I <sub>AR</sub> , V <sub>DD</sub> = 50 V)	130	mJ

## 2 Electrical characteristics

( $T_{CASE} = 25\text{ }^{\circ}\text{C}$  unless otherwise specified)

**Table 4. On/off states**

Symbol	Parameter	Test condition	Min.	Typ.	Max.	Unit
$V_{(BR)DSS}$	Drain-source Breakdown voltage	$I_D = 1\text{ mA}$ , $V_{GS} = 0\text{ V}$	650			V
$I_{DSS}$	Zero gate voltage drain current	$V_{GS} = 0\text{ V}$ , $V_{DS} = 650\text{ V}$			1	$\mu\text{A}$
		$V_{GS} = 0\text{ V}$ , $V_{DS} = 650\text{ V}$ , $T_C = 125\text{ }^{\circ}\text{C}^{(1)}$			100	$\mu\text{A}$
$I_{GSS}$	Gate body leakage current	$V_{DS} = 0\text{ V}$ , $V_{GS} = \pm 25\text{ V}$			$\pm 100$	nA
$V_{GS(th)}$	Gate threshold voltage	$V_{DS} = V_{GS}$ , $I_D = 250\text{ }\mu\text{A}$	3	4	5	V
$R_{DS(on)}$	Static drain-source on resistance	$V_{GS} = 10\text{ V}$ , $I_D = 4.5\text{ A}$		0.43	0.48	$\Omega$

1. Defined by design, not subject to production test.

**Table 5. Dynamic**

Symbol	Parameter	Test condition	Min.	Typ.	Max.	Unit
$C_{iss}$	Input capacitance	$V_{DS} = 100\text{ V}$ , $f = 1\text{ MHz}$ , $V_{GS} = 0\text{ V}$	-	644	-	$\mu\text{F}$
$C_{oss}$	Output capacitance			18		
$C_{rss}$	Reverse transfer capacitance			2.5		
$C_{o(tr)}^{(1)}$	Equivalent capacitance time related	$V_{DS} = 0\text{ to }520\text{ V}$ , $V_{GS} = 0\text{ V}$	-	55	-	$\mu\text{F}$
$C_{o(er)}^{(2)}$	Equivalent capacitance energy related			17		
$R_g$	Gate input resistance	$f = 1\text{ MHz}$ open drain	-	5	-	$\Omega$
$Q_g$	Total gate charge	$V_{DD} = 520\text{ V}$ , $I_D = 4.5\text{ A}$ ,	-	17	-	nC
$Q_{gs}$	Gate-source charge	$V_{GS} = 0\text{ to }10\text{ V}$ (see Figure 20. Test circuit for gate charge behavior)		4.6		
$Q_{gd}$	Gate-drain charge			8.5		

1. Time related is defined as a constant equivalent capacitance giving the same charging time as  $C_{oss}$  when  $V_{DS}$  increases from 0 to 80%  $V_{DSS}$ .

2. Energy related is defined as a constant equivalent capacitance giving the same stored energy as  $C_{oss}$  when  $V_{DS}$  increases from 0 to 80%  $V_{DSS}$ .

**Table 6. Switching times**

Symbol	Parameter	Test condition	Min.	Typ.	Max.	Unit
$t_{d(v)}$	Voltage delay time	$V_{DD} = 400\text{ V}$ , $I_D = 7.5\text{ A}$ , $R_G = 4.7\text{ }\Omega$ , $V_{GS} = 10\text{ V}$ (see Figure 21. Test circuit for inductive load switching and diode recovery times and Figure 24. Switching time waveform)	-	23	-	ns
$t_{r(v)}$	Voltage rise time			10		
$t_{c(off)}$	Crossing time			13		
$t_{f(i)}$	Fall time			13.5		

**Table 7. Source drain diode**

Symbol	Parameter	Test condition	Min.	Typ.	Max.	Unit
$I_{SD}$	Source-drain current				9	A
$I_{SDM}^{(1)}$	Source-drain current (pulsed)		-		36	
$V_{SD}^{(2)}$	Forward on voltage	$I_{SD} = 9\text{ A}$ , $V_{GS} = 0\text{ V}$	-		1.5	V
$t_{rr}$	Reverse recovery time	$I_{SD} = 9\text{ A}$ , $di/dt = 100\text{ A}/\mu\text{s}$		232		ns
$Q_{rr}$	Reverse recovery charge	$V_{DD} = 100\text{ V}$ (see Figure 21. Test circuit for inductive load switching and diode recovery times)	-	2		$\mu\text{C}$
$I_{RRM}$	Reverse recovery current			17.5		A
$t_{rr}$	Reverse recovery time	$I_{SD} = 9\text{ A}$ , $di/dt = 100\text{ A}/\mu\text{s}$		328		ns
$Q_{rr}$	Reverse recovery charge	$V_{DD} = 100\text{ V}$ , $T_j = 150\text{ }^\circ\text{C}$ (see Figure 21. Test circuit for inductive load switching and diode recovery times)	-	2.8		$\mu\text{C}$
$I_{RRM}$	Reverse recovery current			17		A

1. Pulse width limited by safe operating area.

2. Pulsed: pulse duration = 300  $\mu\text{s}$ , duty cycle 1.5%.

## 2.1 Electrical characteristics curves

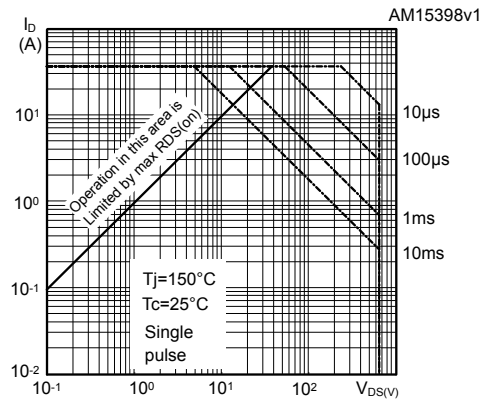
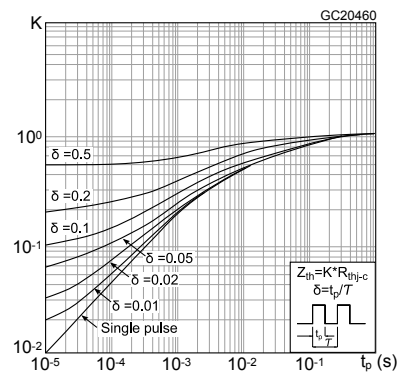
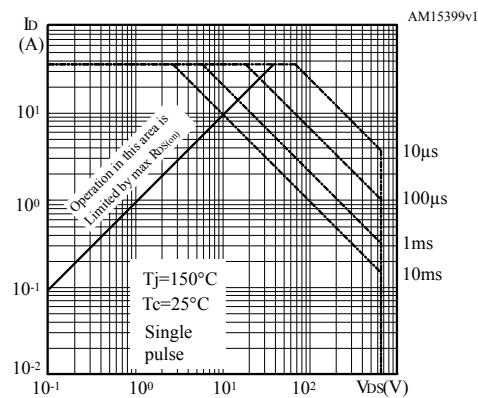
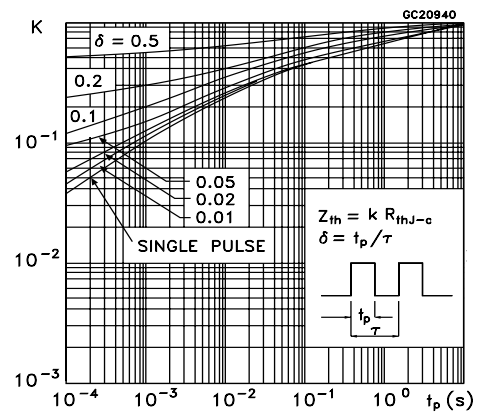
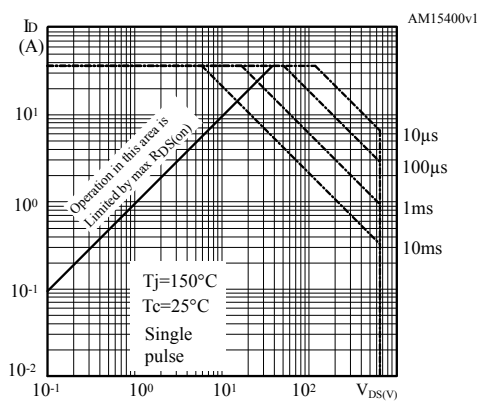
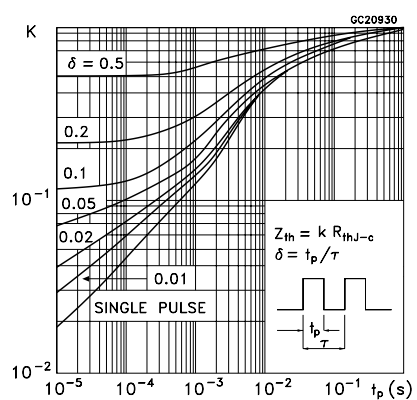
**Figure 1. Safe operating area for DPAK**

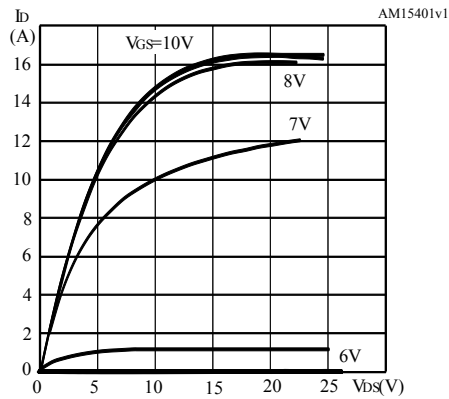
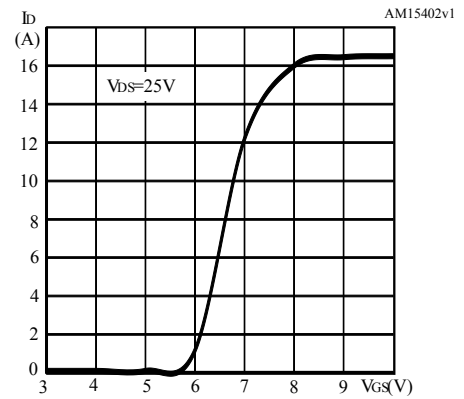
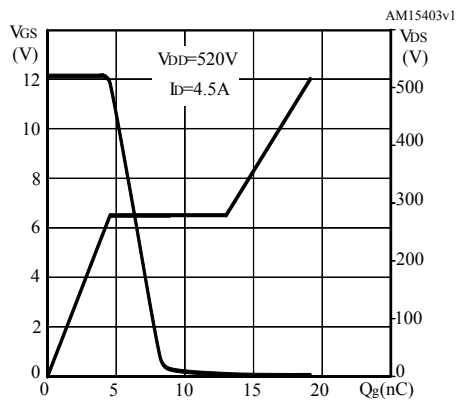
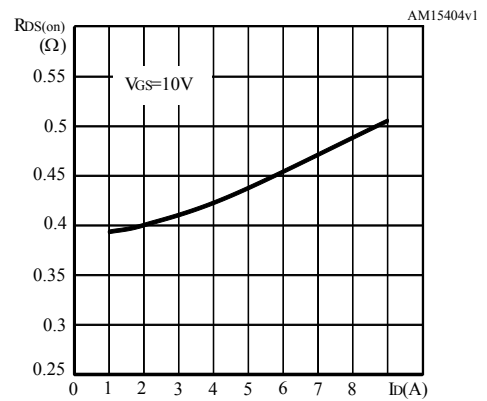
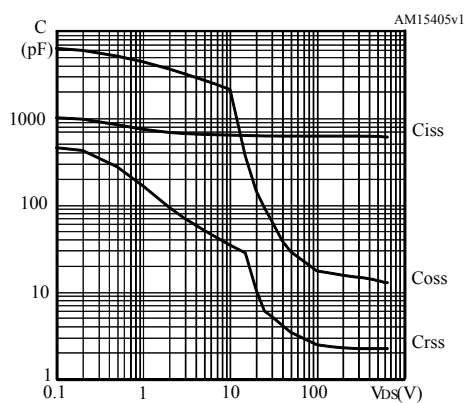
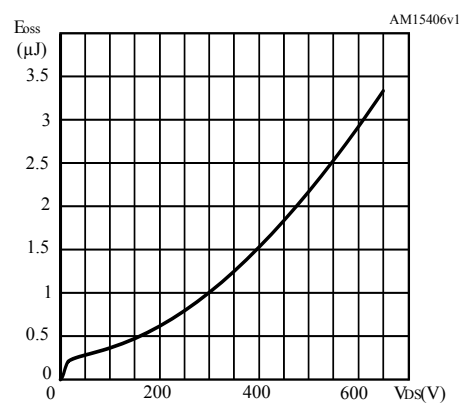
**Figure 2. Thermal impedance DPAK**

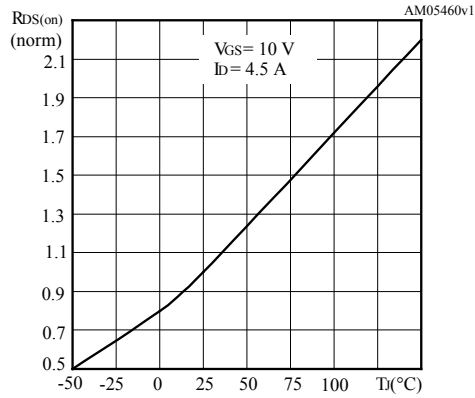
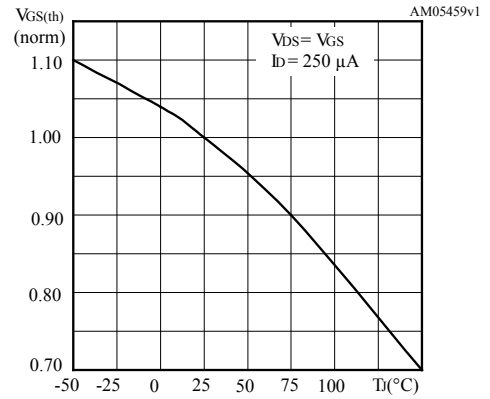
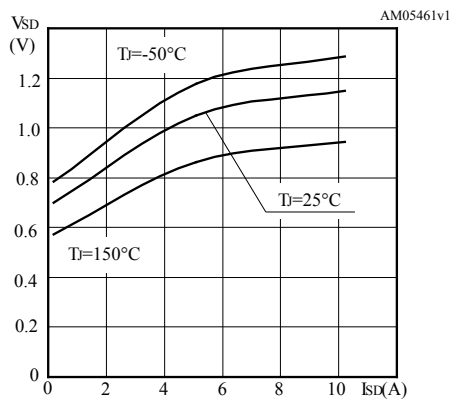
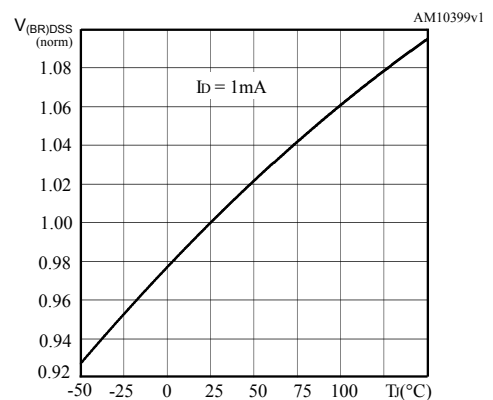
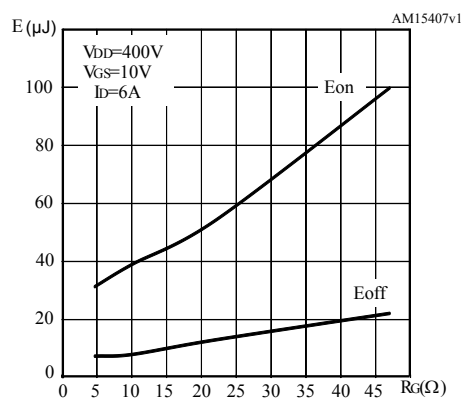
**Figure 3. Safe operating area for TO-220FP**

**Figure 4. Thermal impedance for TO-220FP**

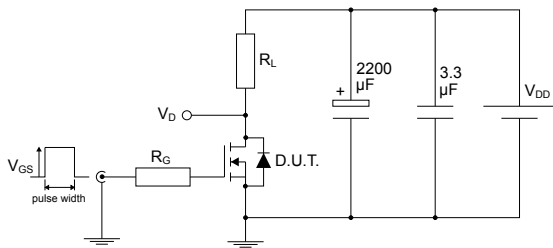
**Figure 5. Safe operating area for TO-220 and D<sup>2</sup>PAK**

**Figure 6. Thermal impedance for TO-220 and D<sup>2</sup>PAK**

**Figure 8. Output characteristics**

**Figure 9. Transfer characteristics**

**Figure 10. Gate charge vs gate-source voltage**

**Figure 11. Static drain-source on resistance**

**Figure 12. Capacitance variations**

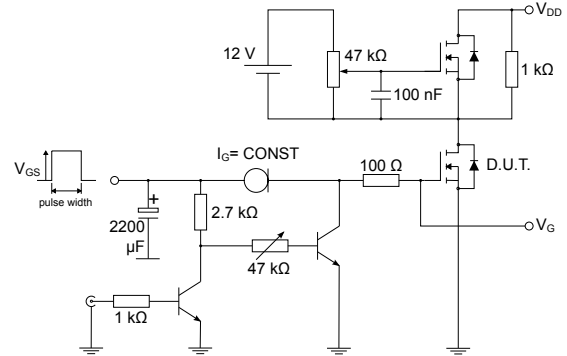
**Figure 13. Output capacitance stored energy**

**Figure 14. Normalized on-resistance vs temperature**

**Figure 15. Normalized gate threshold voltage vs temperature**

**Figure 16. Drain-source diode forward characteristics**

**Figure 17. Normalized  $V_{(BR)DSS}$  vs temperature**

**Figure 18. Switching energy vs gate resistance**

### 3 Test circuits

**Figure 19. Test circuit for resistive load switching times**

AM01468v1

**Figure 20. Test circuit for gate charge behavior**

AM01469v1

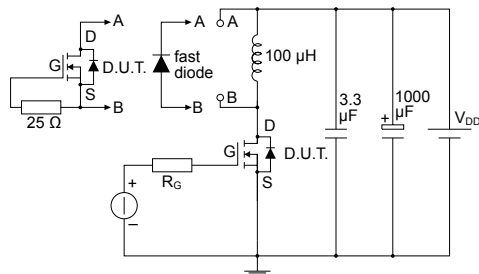
**Figure 21. Test circuit for inductive load switching and diode recovery times**

AM01470v1

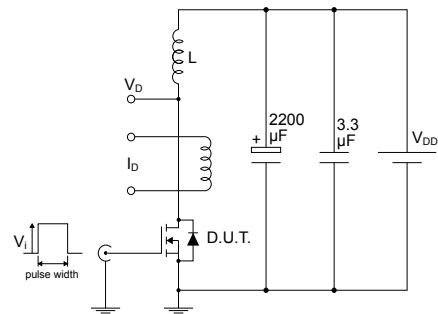
**Figure 22. Unclamped inductive load test circuit**

AM01471v1

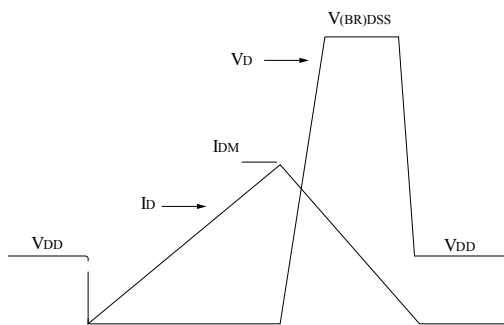
**Figure 23. Unclamped inductive waveform**

AM01472v1

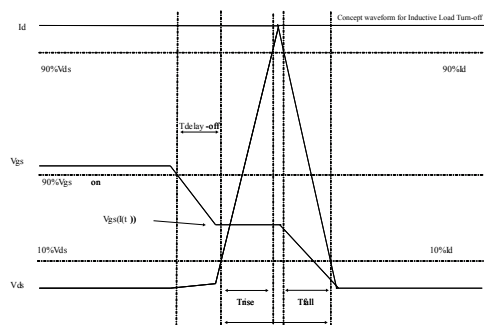
**Figure 24. Switching time waveform**

AM05540v2\_for\_M5



## 4 Package information

---

In order to meet environmental requirements, ST offers these devices in different grades of ECOPACK® packages, depending on their level of environmental compliance. ECOPACK® specifications, grade definitions and product status are available at: [www.st.com](http://www.st.com). ECOPACK® is an ST trademark.

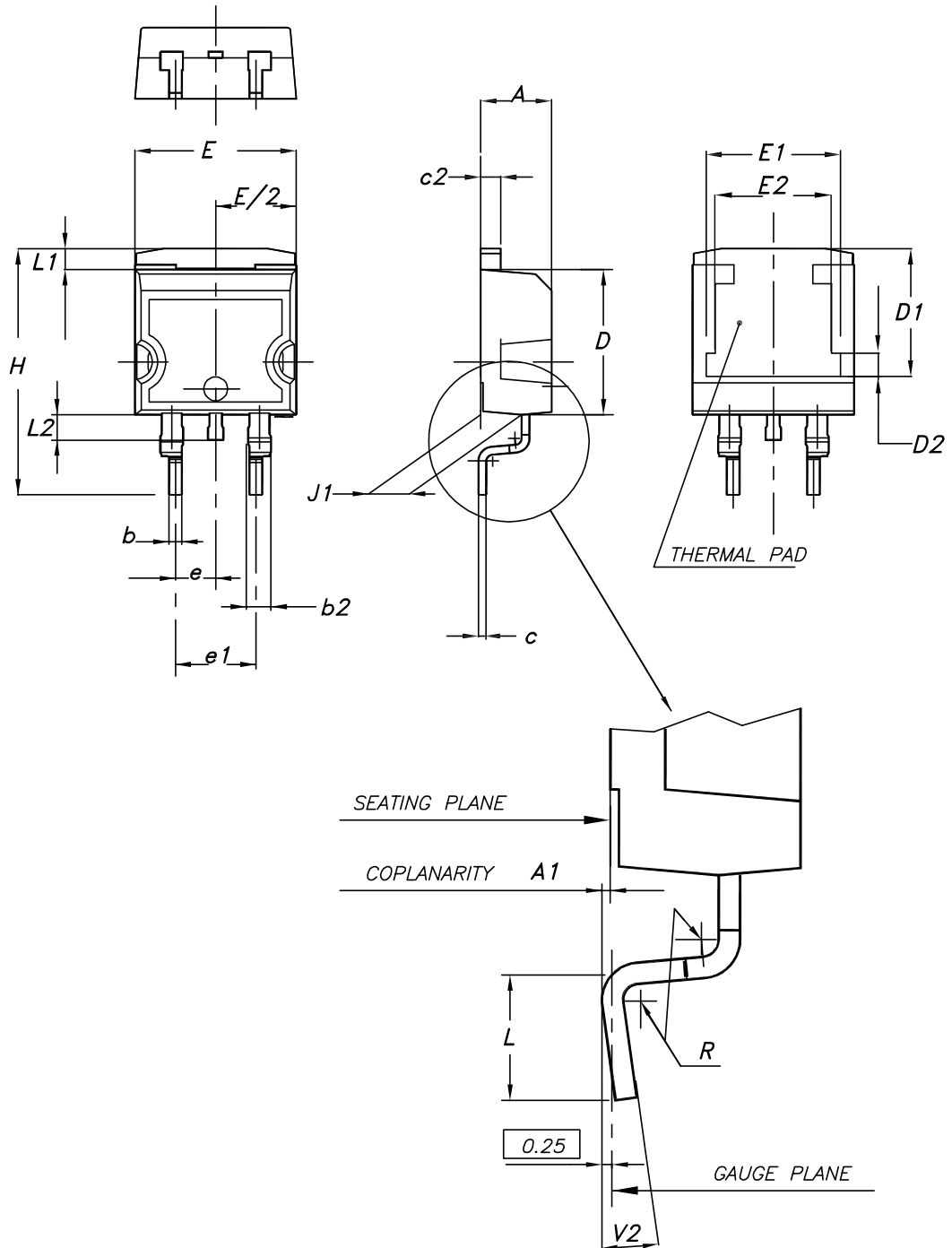
**4.1 D<sup>2</sup>PAK (TO-263) type A package information**
**Figure 25. D<sup>2</sup>PAK (TO-263) type A package outline**

0079457\_25

**Table 8. D<sup>2</sup>PAK (TO-263) type A package mechanical data**

Dim.	mm		
	Min.	Typ.	Max.
A	4.40		4.60
A1	0.03		0.23
b	0.70		0.93
b2	1.14		1.70
c	0.45		0.60
c2	1.23		1.36
D	8.95		9.35
D1	7.50	7.75	8.00
D2	1.10	1.30	1.50
E	10.00		10.40
E1	8.30	8.50	8.70
E2	6.85	7.05	7.25
e		2.54	
e1	4.88		5.28
H	15.00		15.85
J1	2.49		2.69
L	2.29		2.79
L1	1.27		1.40
L2	1.30		1.75
R		0.40	
V2	0°		8°

Figure 26. D<sup>2</sup>PAK (TO-263) recommended footprint (dimensions are in mm)

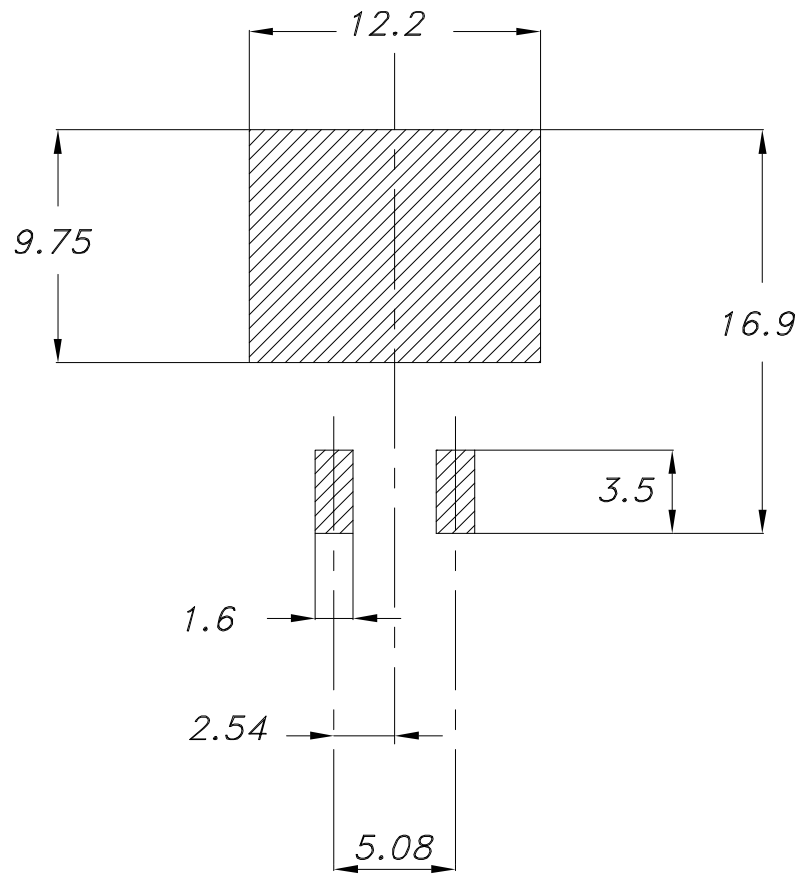

Footprint

## 4.2 D<sup>2</sup>PAK packing information

Figure 27. D<sup>2</sup>PAK tape outline

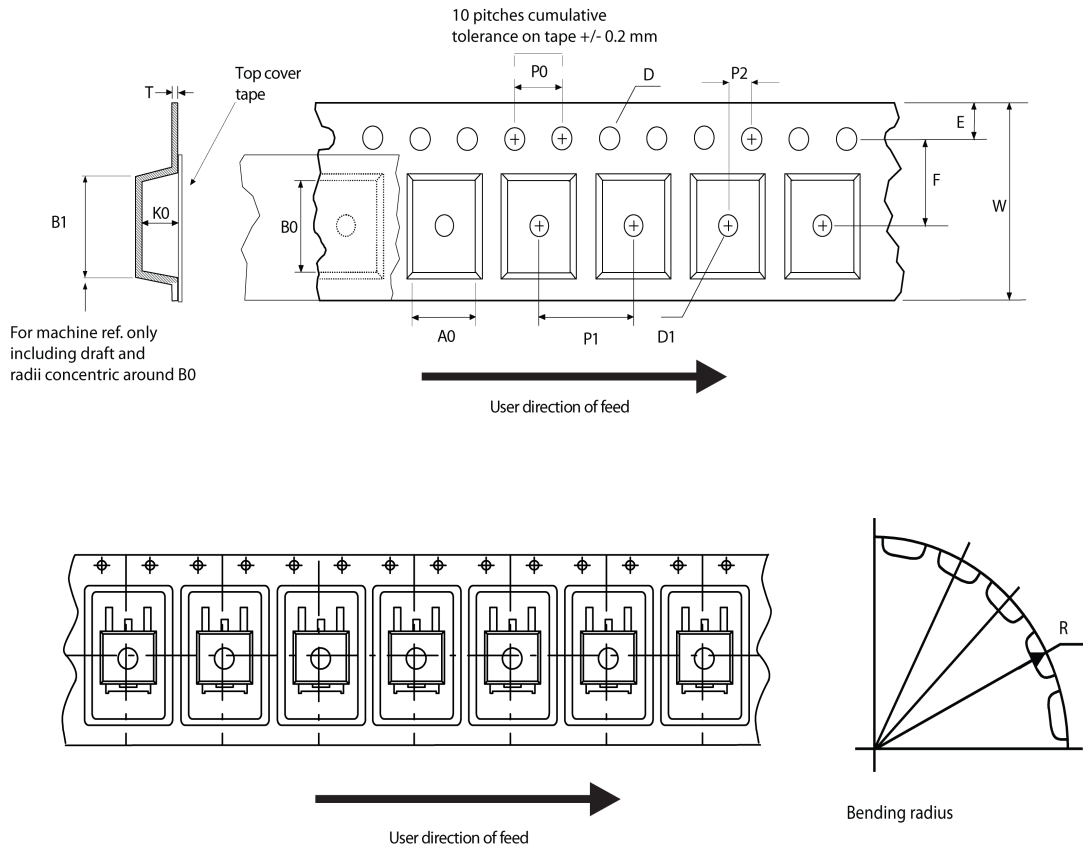

AM08852v1

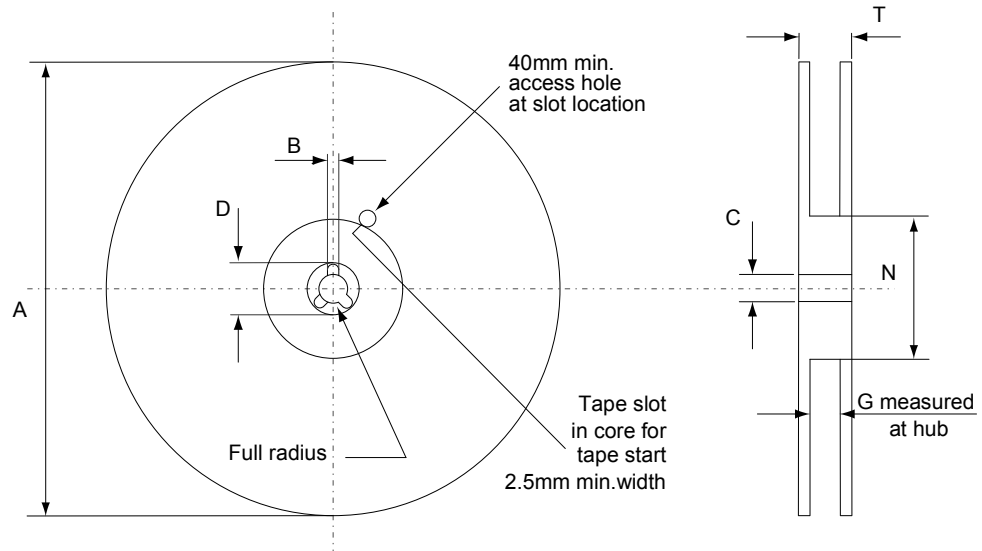
**Figure 28. D<sup>2</sup>PAK reel outline**

AM06038v1

**Table 9. D<sup>2</sup>PAK tape and reel mechanical data**

Tape			Reel			
Dim.	mm		Dim.	mm		
	Min.	Max.		Min.	Max.	
A0	10.5	10.7	A		330	
B0	15.7	15.9	B	1.5		
D	1.5	1.6	C	12.8	13.2	
D1	1.59	1.61	D	20.2		
E	1.65	1.85	G	24.4	26.4	
F	11.4	11.6	N	100		
K0	4.8	5.0	T		30.4	
P0	3.9	4.1	Base quantity Bulk quantity			
P1	11.9	12.1				1000
P2	1.9	2.1				1000
R	50					
T	0.25	0.35				
W	23.7	24.3				

### 4.3 DPAK (TO-252) type A package information

Figure 29. DPAK (TO-252) type A package outline

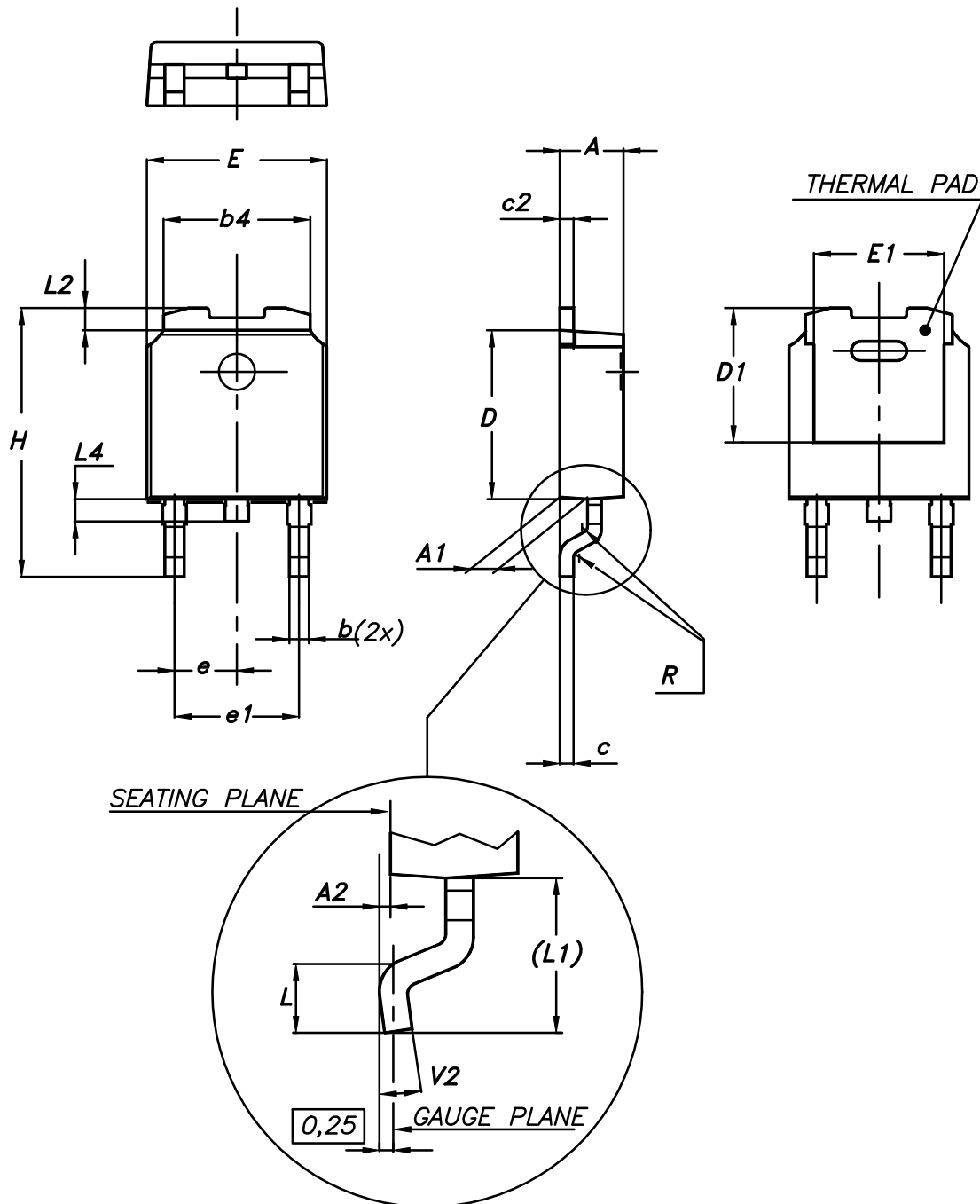

0068772\_A\_25

**Table 10. DPAK (TO-252) type A mechanical data**

Dim.	mm		
	Min.	Typ.	Max.
A	2.20		2.40
A1	0.90		1.10
A2	0.03		0.23
b	0.64		0.90
b4	5.20		5.40
c	0.45		0.60
c2	0.48		0.60
D	6.00		6.20
D1	4.95	5.10	5.25
E	6.40		6.60
E1	4.60	4.70	4.80
e	2.159	2.286	2.413
e1	4.445	4.572	4.699
H	9.35		10.10
L	1.00		1.50
(L1)	2.60	2.80	3.00
L2	0.65	0.80	0.95
L4	0.60		1.00
R		0.20	
V2	0°		8°

#### 4.4 DPAK (TO-252) type C2 package information

Figure 30. DPAK (TO-252) type C2 package outline

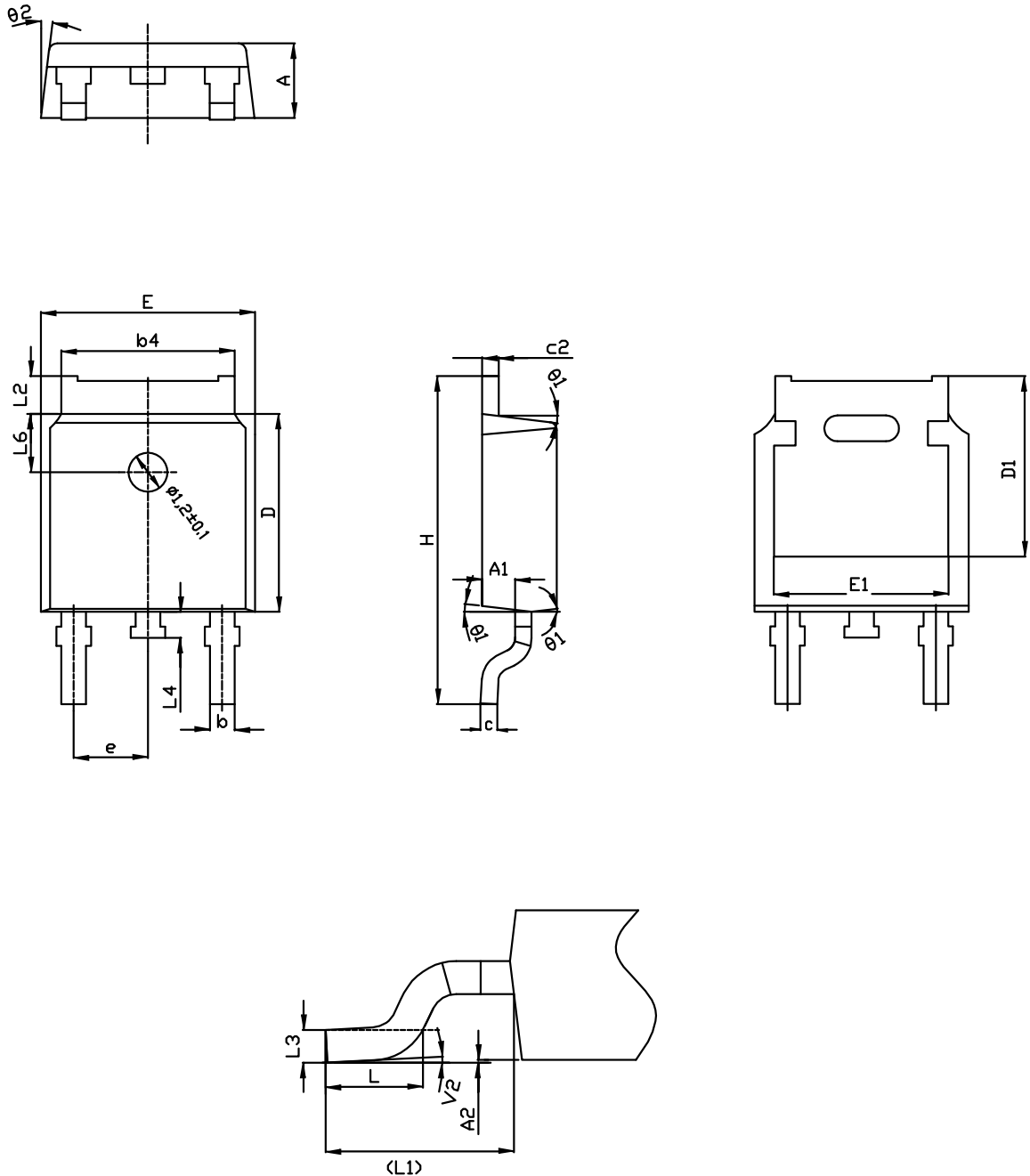

0068772\_C2\_25

**Table 11. DPAK (TO-252) type C2 mechanical data**

Dim.	mm		
	Min.	Typ.	Max.
A	2.20	2.30	2.38
A1	0.90	1.01	1.10
A2	0.00		0.10
b	0.72		0.85
b4	5.13	5.33	5.46
c	0.47		0.60
c2	0.47		0.60
D	6.00	6.10	6.20
D1	5.10		5.60
E	6.50	6.60	6.70
E1	5.20		5.50
e	2.186	2.286	2.386
H	9.80	10.10	10.40
L	1.40	1.50	1.70
L1	2.90 REF		
L2	0.90		1.25
L3	0.51 BSC		
L4	0.60	0.80	1.00
L6	1.80 BSC		
θ1	5°	7°	9°
θ2	5°	7°	9°
V2	0°		8°

### 4.5 DPAK (TO-252) type E package information

Figure 31. DPAK (TO-252) type E package outline

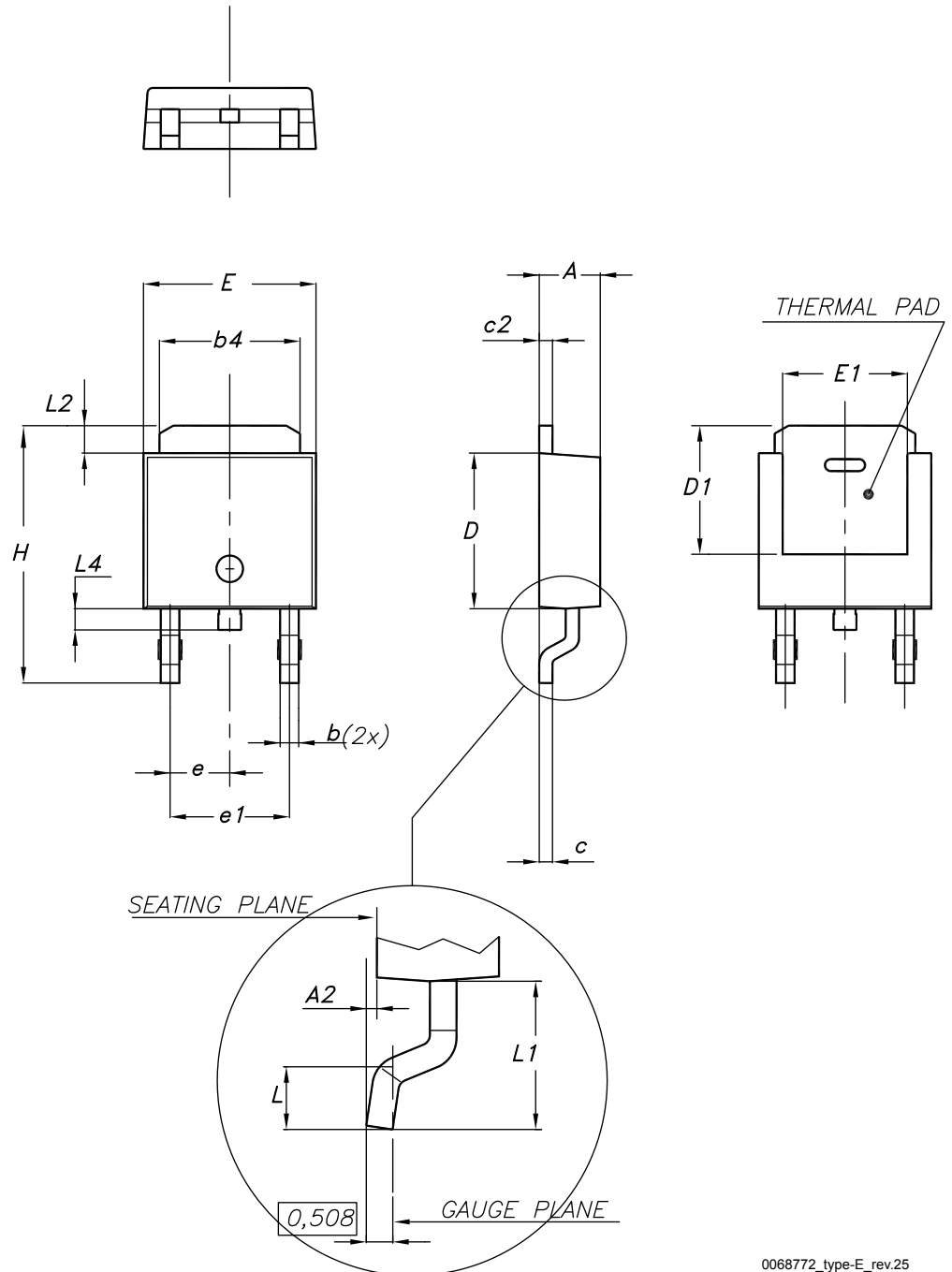

0068772\_type-E\_rev.25

**Table 12. DPAK (TO-252) type E mechanical data**

Dim.	mm		
	Min.	Typ.	Max.
A	2.18		2.39
A2			0.13
b	0.65		0.884
b4	4.95		5.46
c	0.46		0.61
c2	0.46		0.60
D	5.97		6.22
D1	5.21		
E	6.35		6.73
E1	4.32		
e		2.286	
e1		4.572	
H	9.94		10.34
L	1.50		1.78
L1		2.74	
L2	0.89		1.27
L4			1.02

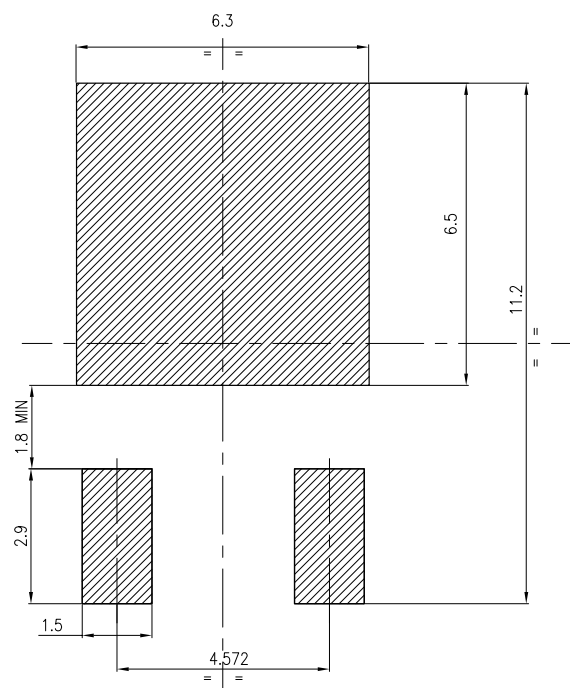
**Figure 32. DPAK (TO-252) recommended footprint (dimensions are in mm)**

FP\_0068772\_25

## 4.6 DPAK (TO-252) packing information

Figure 33. DPAK (TO-252) tape outline

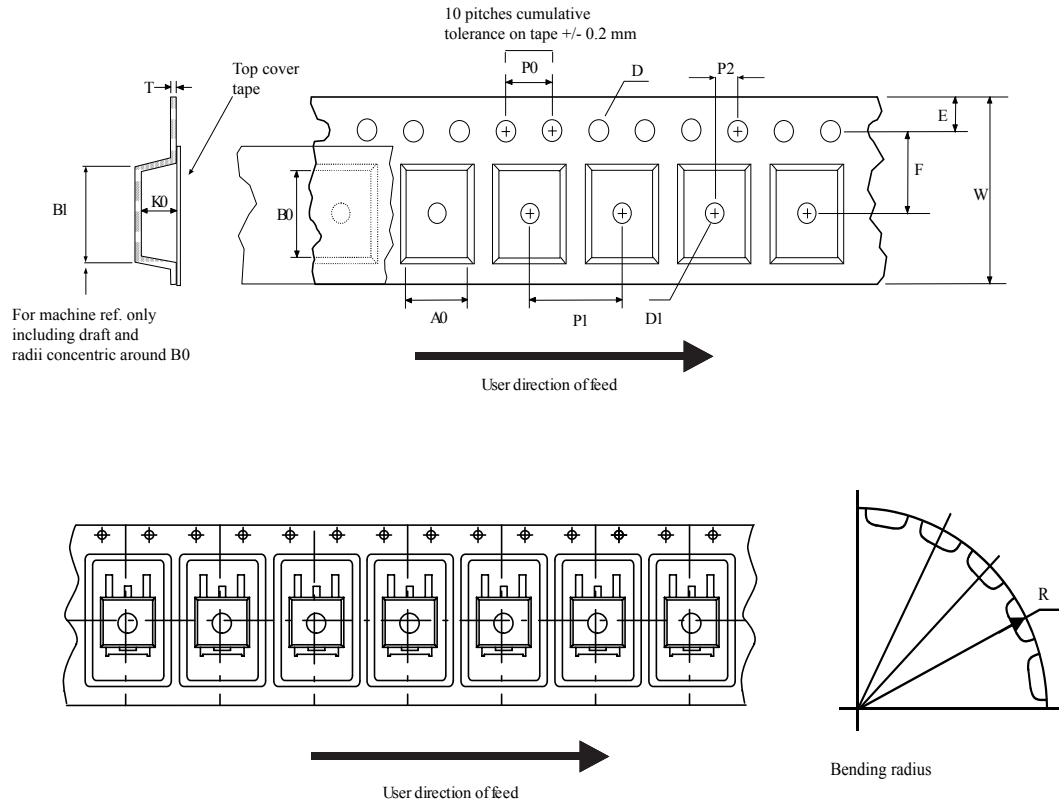

AM08852v1

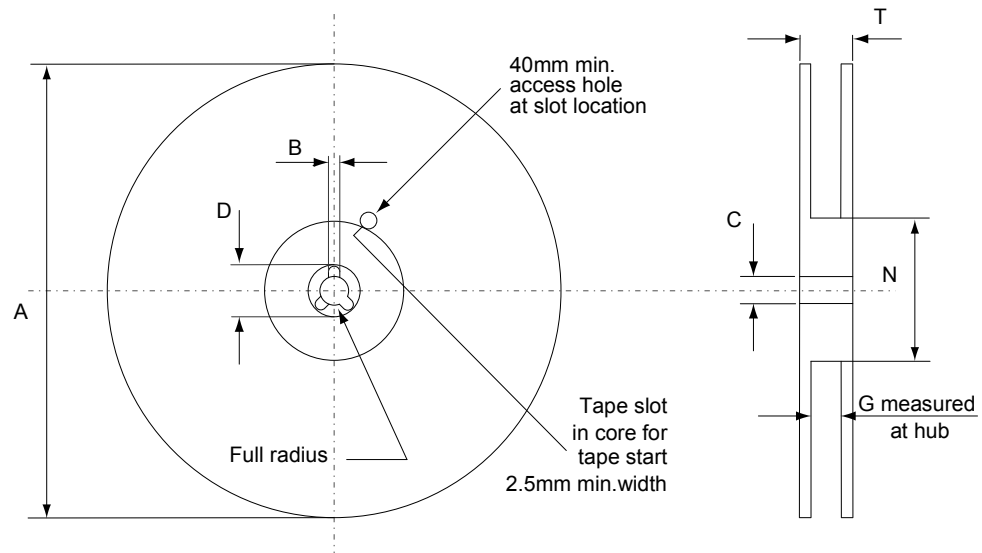
**Figure 34. DPAK (TO-252) reel outline**

AM06038v1

**Table 13. DPAK (TO-252) tape and reel mechanical data**

Tape			Reel		
Dim.	mm		Dim.	mm	
	Min.	Max.		Min.	Max.
A0	6.8	7	A		330
B0	10.4	10.6	B	1.5	
B1		12.1	C	12.8	13.2
D	1.5	1.6	D	20.2	
D1	1.5		G	16.4	18.4
E	1.65	1.85	N	50	
F	7.4	7.6	T		22.4
K0	2.55	2.75			
P0	3.9	4.1	Base qty.		2500
P1	7.9	8.1	Bulk qty.		2500
P2	1.9	2.1			
R	40				
T	0.25	0.35			
W	15.7	16.3			

4.7 TO-220FP package information

Figure 35. TO-220FP package outline

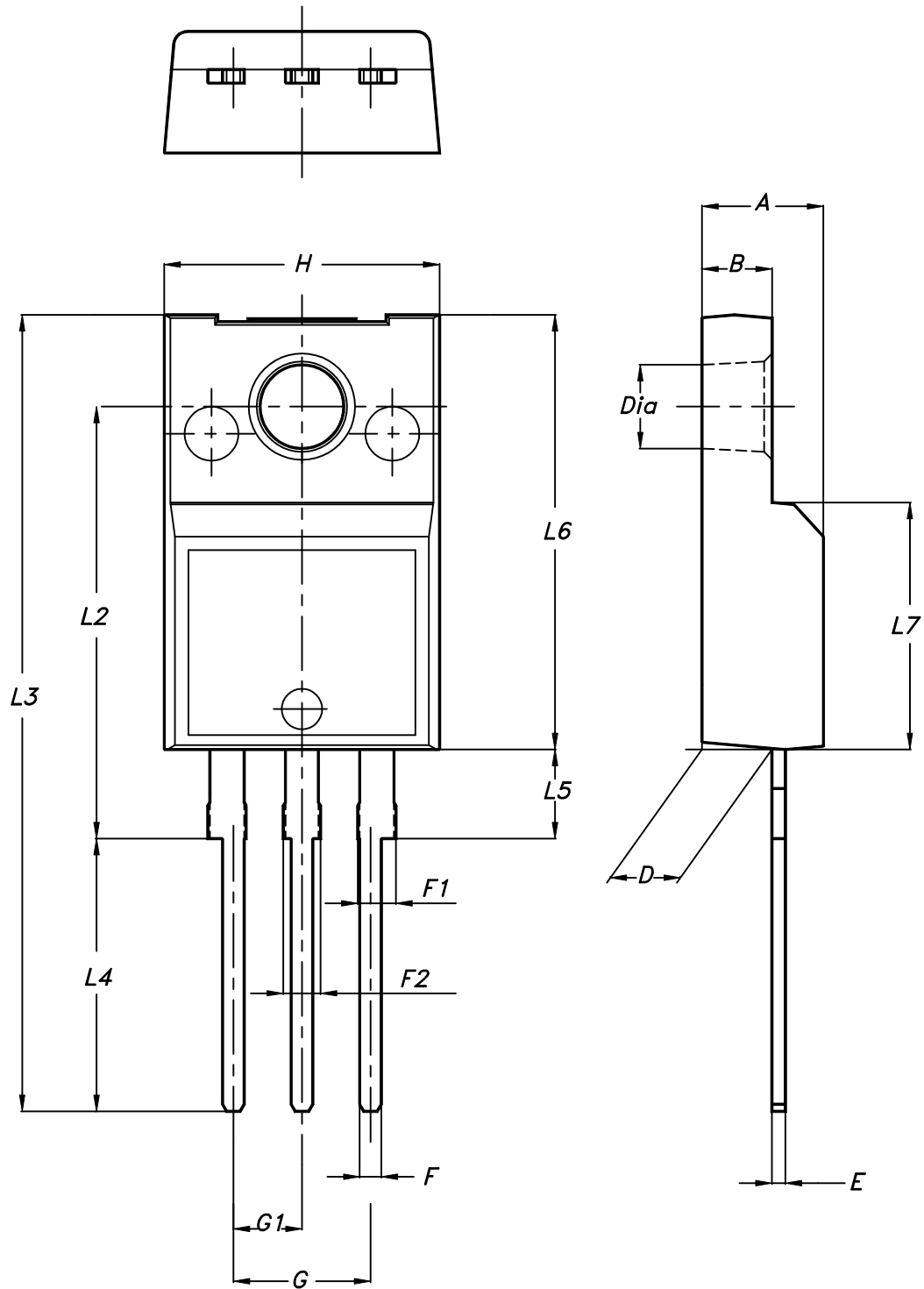

7012510\_Rev\_12\_B

**Table 14. TO-220FP package mechanical data**

Dim.	mm		
	Min.	Typ.	Max.
A	4.4		4.6
B	2.5		2.7
D	2.5		2.75
E	0.45		0.7
F	0.75		1
F1	1.15		1.70
F2	1.15		1.70
G	4.95		5.2
G1	2.4		2.7
H	10		10.4
L2		16	
L3	28.6		30.6
L4	9.8		10.6
L5	2.9		3.6
L6	15.9		16.4
L7	9		9.3
Dia	3		3.2

4.8 TO-220 type A package information

Figure 36. TO-220 type A package outline

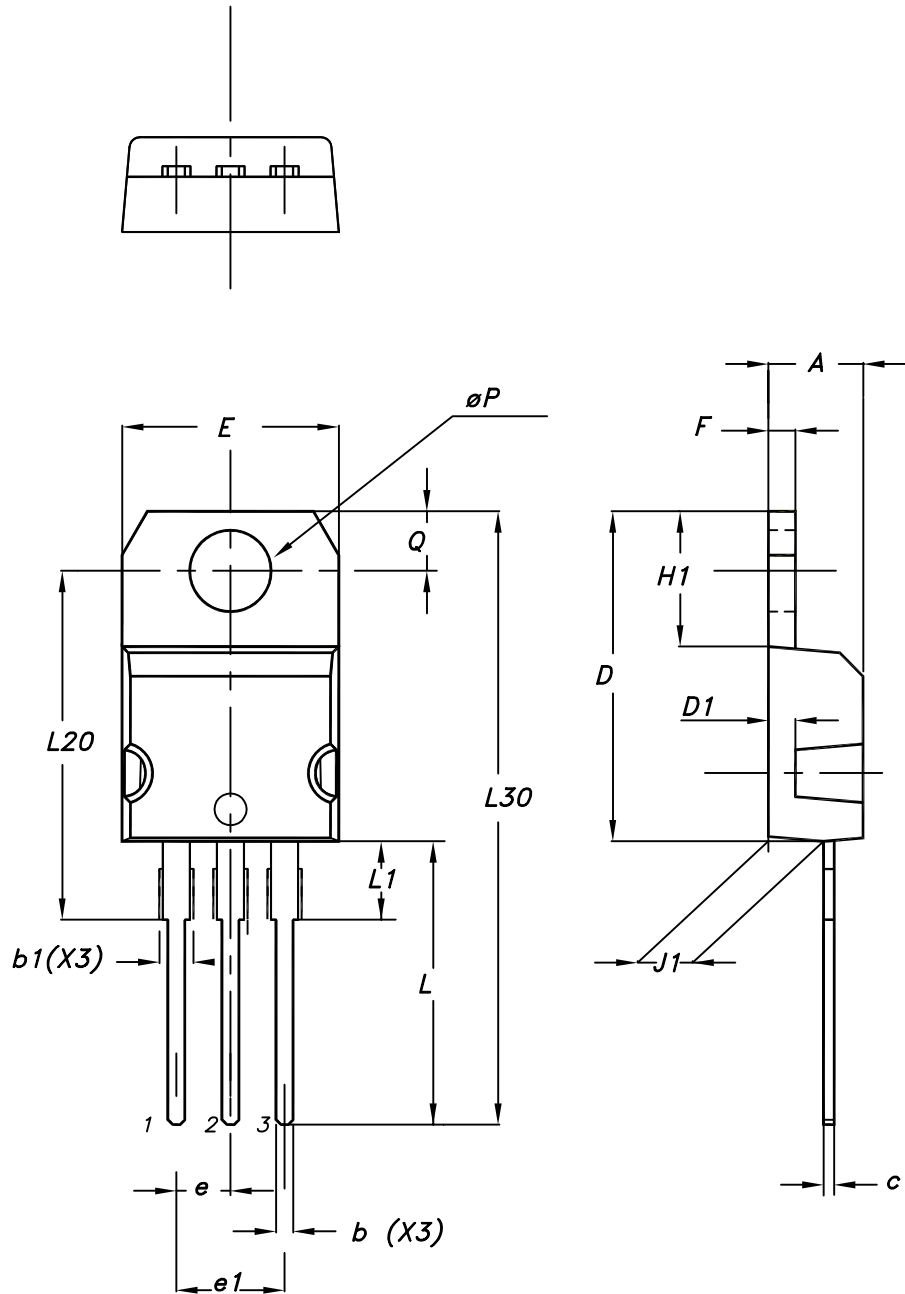

0015988\_typeA\_Rev\_21

**Table 15. TO-220 type A package mechanical data**

Dim.	mm		
	Min.	Typ.	Max.
A	4.40		4.60
b	0.61		0.88
b1	1.14		1.55
c	0.48		0.70
D	15.25		15.75
D1		1.27	
E	10.00		10.40
e	2.40		2.70
e1	4.95		5.15
F	1.23		1.32
H1	6.20		6.60
J1	2.40		2.72
L	13.00		14.00
L1	3.50		3.93
L20		16.40	
L30		28.90	
øP	3.75		3.85
Q	2.65		2.95

## 5 Ordering information

**Table 16. Order codes**

Order code	Marking	Package	Packing
STB11N65M5	11N65M5	D <sup>2</sup> PAK	Tape and reel
STD11N65M5		DPAK	
STF11N65M5		TO-220FP	Tube
STP11N65M5		TO-220	

## Revision history

**Table 17. Document revision history**

Date	Version	Changes
23-Feb-2012	1	First release.
03-Dec-2012	2	<ul style="list-style-type: none"> <li>– Minor text changes in cover page</li> <li>– Added IPAK packages</li> <li>– Added <i>Section 2.1: Electrical characteristics (curves)</i></li> <li>– Updated <i>Section 5: Packaging mechanical data</i></li> <li>– Modified: <i>note 2</i> on <i>Table 2</i></li> <li>– Updated: mechanical data for TO-220FP package</li> </ul>
02-May-2018	3	<p>The part number STU11N65M5 has been moved to a separate datasheet.</p> <p>Removed maturity status indication from cover page. The document status is production data.</p> <p>Updated title and features in cover page, <a href="#">Section 1 Electrical ratings</a>, <a href="#">Section 2 Electrical characteristics</a>, <a href="#">Section 2.1 Electrical characteristics curves</a> and <a href="#">Section 4 Package information</a>.</p> <p>Minor text changes.</p>

## Contents

<b>1</b>	<b>Electrical ratings</b> .....	<b>2</b>
<b>2</b>	<b>Electrical characteristics</b> .....	<b>3</b>
<b>2.1</b>	Electrical characteristics curves .....	5
<b>3</b>	<b>Test circuits</b> .....	<b>8</b>
<b>4</b>	<b>Package information</b> .....	<b>9</b>
<b>4.1</b>	D <sup>2</sup> PAK (TO-263) type A package information .....	9
<b>4.2</b>	D <sup>2</sup> PAK packing information .....	12
<b>4.3</b>	DPAK (TO-252) type A package information .....	14
<b>4.4</b>	DPAK (TO-252) type C2 package information .....	16
<b>4.5</b>	DPAK (TO-252) type E package information .....	18
<b>4.6</b>	DPAK (TO-252) packing information .....	20
<b>4.7</b>	TO-220FP package information .....	22
<b>4.8</b>	TO-220 type A package information .....	24
<b>5</b>	<b>Ordering information</b> .....	<b>27</b>
	<b>Revision history</b> .....	<b>28</b>



**IMPORTANT NOTICE – PLEASE READ CAREFULLY**

STMicroelectronics NV and its subsidiaries (“ST”) reserve the right to make changes, corrections, enhancements, modifications, and improvements to ST products and/or to this document at any time without notice. Purchasers should obtain the latest relevant information on ST products before placing orders. ST products are sold pursuant to ST’s terms and conditions of sale in place at the time of order acknowledgement.

Purchasers are solely responsible for the choice, selection, and use of ST products and ST assumes no liability for application assistance or the design of Purchasers’ products.

No license, express or implied, to any intellectual property right is granted by ST herein.

Resale of ST products with provisions different from the information set forth herein shall void any warranty granted by ST for such product.



ST and the ST logo are trademarks of ST. All other product or service names are the property of their respective owners.

Information in this document supersedes and replaces information previously supplied in any prior versions of this document.







© 2018 STMicroelectronics – All rights reserved

## Looking for pricing, stock, or lifecycle information?

Click below to explore more details on WIN SOURCE:

-  [View STB11N65M5 on WIN SOURCE](#)
-  [STMicroelectronics Information](#)

## Optimize Your Supply Chain with WIN SOURCE Solutions

-  Global Sourcing Solution
-  Obsolete Management
-  Cost Control Management
-  Shortage Management
-  Alternative Solution
-  Excess Inventory Management