



THE DATASHEET OF
83905AGLFT



General Description

The 83905 is a low skew, 1-to-6 LVCMOS / LVTTTL Fanout Buffer. The low impedance LVCMOS/LVTTTL outputs are designed to drive 50Ω series or parallel terminated transmission lines. The effective fanout can be increased from 6 to 12 by utilizing the ability of the outputs to drive two series terminated lines.

The 83905 is characterized at full 3.3V, 2.5V, and 1.8V, mixed 3.3V/2.5V, 3.3V/1.8V and 2.5V/1.8V output operating supply mode. Guaranteed output and part-to-part skew characteristics along with the 1.8V output capabilities makes the 83905 ideal for high performance, single ended applications that also require a limited output voltage.

Pin Assignments

83905
20-Lead VFQFN
4mm x 4mm x 0.925mm
package body
K Package
Top View

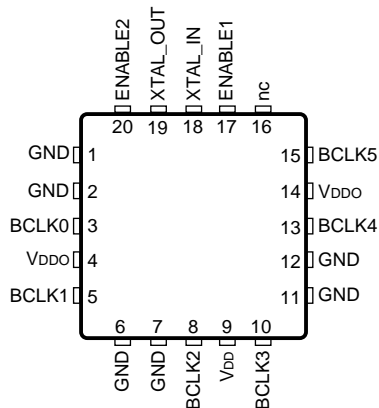

83905
16-Lead SOIC, 150 Mil
3.9mm x 9.9mm x 1.38mm
package body
M Package
Top View

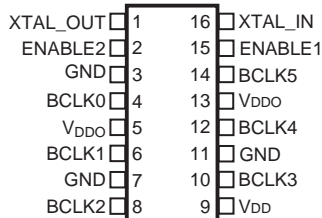

16-Lead TSSOP
4.4mm x 5.0mm x 0.925mm
package body
G Package
Top View

Features

- Six LVCMOS / LVTTTL outputs
- Outputs able to drive 12 series terminated lines
- Crystal Oscillator Interface
- Crystal input frequency range: 10MHz to 40MHz
- Output skew: 80ps (maximum)
- RMS phase jitter @ 25MHz, (100Hz – 1MHz): 0.26ps (typical), $V_{DD} = V_{DD0} = 2.5V$

Offset	Noise Power
100Hz	-129.7 dBc/Hz
1kHz	-144.4 dBc/Hz
10kHz	-147.3 dBc/Hz
100kHz	-157.3 dBc/Hz

- 5V tolerant enable inputs
- Synchronous output enables
- Operating power supply modes:
Full 3.3V, 2.5V, 1.8V
Mixed 3.3V core/2.5V output operating supply
Mixed 3.3V core/1.8V output operating supply
Mixed 2.5V core/1.8V output operating supply
- 0°C to 70°C ambient operating temperature
- Lead-free (RoHS 6) packaging

Block Diagram

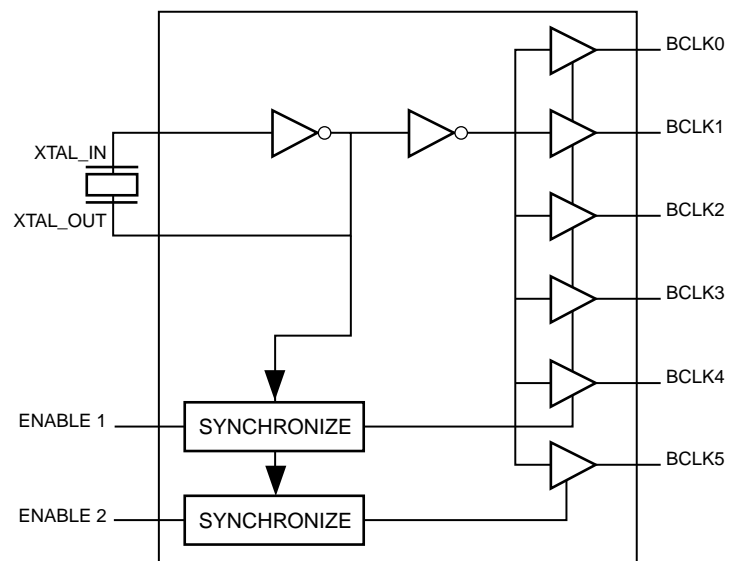

Pin Descriptions and Characteristics

Table 1. Pin Descriptions

Name	Type	Description
XTAL_OUT	Output	Crystal oscillator interface. XTAL_OUT is the output.
XTAL_IN	Input	Crystal oscillator interface. XTAL_IN is the input.
ENABLE1, ENABLE2	Input	Clock enable. LVCMOS/LVTTL interface levels. See Table 3.
BCLK0, BCLK1, BCLK2, BCLK3, BCLK4, BCLK5	Output	Clock outputs. LVCMOS/LVTTL interface levels.
GND	Power	Power supply ground.
V _{DD}	Power	Power supply pin.
V _{DDO}	Power	Output supply pin.
nc	Unused	No connect.

Table 2. Pin Characteristics

Symbol	Parameter	Test Conditions	Minimum	Typical	Maximum	Units
C _{IN}	Input Capacitance			4		pF
C _{PD}	Power Dissipation Capacitance (per output)	V _{DDO} = 3.465V			19	pF
		V _{DDO} = 2.625V			18	pF
		V _{DDO} = 2.0V			16	pF
R _{OUT}	Output Impedance	V _{DDO} = 3.3V ± 5%		7		Ω
		V _{DDO} = 2.5V ± 5%		7		Ω
		V _{DDO} = 1.8V ± 0.2V		10		Ω

Function Table

Table 3. Clock Enable Function Table

Control Inputs		Outputs	
ENABLE 1	ENABLE2	BCLK[0:4]	BCLK5
0	0	LOW	LOW
0	1	LOW	Toggling
1	0	Toggling	LOW
1	1	Toggling	Toggling

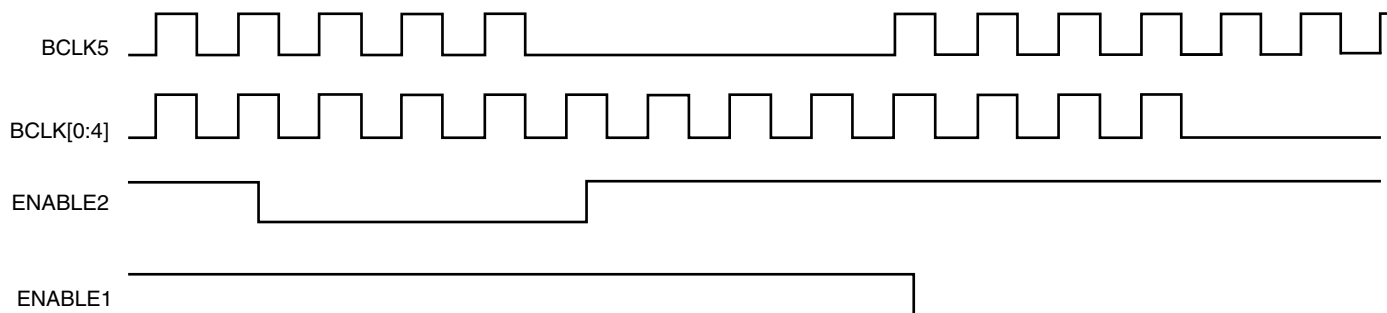
Figure 1. Enable Timing Diagram

Absolute Maximum Ratings

NOTE: Stresses beyond those listed under *Absolute Maximum Ratings* may cause permanent damage to the device. These ratings are stress specifications only. Functional operation of product at these conditions or any conditions beyond those listed in the *DC Characteristics* or *AC Characteristics* is not implied. Exposure to absolute maximum rating conditions for extended periods may affect product reliability.

Item	Rating
Supply Voltage, V_{DD}	4.6V
Inputs, V_I	-0.5V to $V_{DD} + 0.5V$
Outputs, V_O	-0.5V to $V_{DDO} + 0.5V$
Package Thermal Impedance, θ_{JA} 16-Lead SOIC package 16-Lead TSSOP package 20-Lead VFQFN package	78.8°C/W (0 mps) 100.3°C/W (0 mps) 57.5°C/W (0 mps)
Storage Temperature, T_{STG}	-65°C to 150°C

DC Electrical Characteristics

Table 4A. Power Supply DC Characteristics, $V_{DD} = V_{DDO} = 3.3V \pm 5\%$, $T_A = 0^\circ C$ to $70^\circ C$

Symbol	Parameter	Test Conditions	Minimum	Typical	Maximum	Units
V_{DD}	Power Supply Voltage		3.135	3.3	3.465	V
V_{DDO}	Output Supply Voltage		3.135	3.3	3.465	V
I_{DD}	Power Supply Current	ENABLE [1:2] = 00			10	mA
I_{DDO}	Output Supply Current	ENABLE [1:2] = 00			5	mA

Table 4B. Power Supply DC Characteristics, $V_{DD} = V_{DDO} = 2.5V \pm 5\%$, $T_A = 0^\circ C$ to $70^\circ C$

Symbol	Parameter	Test Conditions	Minimum	Typical	Maximum	Units
V_{DD}	Power Supply Voltage		2.375	2.5	2.625	V
V_{DDO}	Output Supply Voltage		2.375	2.5	2.625	V
I_{DD}	Power Supply Current	ENABLE [1:2] = 00			8	mA
I_{DDO}	Output Supply Current	ENABLE [1:2] = 00			4	mA

Table 4C. Power Supply DC Characteristics, $V_{DD} = V_{DDO} = 1.8V \pm 0.2V$, $T_A = 0^\circ C$ to $70^\circ C$

Symbol	Parameter	Test Conditions	Minimum	Typical	Maximum	Units
V_{DD}	Power Supply Voltage		1.6	1.8	2.0	V
V_{DDO}	Output Supply Voltage		1.6	1.8	2.0	V
I_{DD}	Power Supply Current	ENABLE [1:2] = 00			5	mA
I_{DDO}	Output Supply Current	ENABLE [1:2] = 00			3	mA

Table 4D. Power Supply DC Characteristics, $V_{DD} = 3.3V \pm 5\%$, $V_{DDO} = 2.5V \pm 5\%$, $T_A = 0^\circ\text{C}$ to 70°C

Symbol	Parameter	Test Conditions	Minimum	Typical	Maximum	Units
V_{DD}	Power Supply Voltage		3.135	3.3	3.465	V
V_{DDO}	Output Supply Voltage		2.375	2.5	2.625	V
I_{DD}	Power Supply Current	ENABLE [1:2] = 00			10	mA
I_{DDO}	Output Supply Current	ENABLE [1:2] = 00			4	mA

Table 4E. Power Supply DC Characteristics, $3.3V \pm 5\%$, $V_{DDO} = 1.8V \pm 0.2V$, $T_A = 0^\circ\text{C}$ to 70°C

Symbol	Parameter	Test Conditions	Minimum	Typical	Maximum	Units
V_{DD}	Power Supply Voltage		3.135	3.3	3.465	V
V_{DDO}	Output Supply Voltage		1.6	1.8	2.0	V
I_{DD}	Power Supply Current	ENABLE [1:2] = 00			10	mA
I_{DDO}	Output Supply Current	ENABLE [1:2] = 00			3	mA

Table 4F. Power Supply DC Characteristics, $V_{DD} = 2.5V \pm 5\%$, $V_{DDO} = 1.8V \pm 0.2V$, $T_A = 0^\circ\text{C}$ to 70°C

Symbol	Parameter	Test Conditions	Minimum	Typical	Maximum	Units
V_{DD}	Power Supply Voltage		2.375	2.5	2.625	V
V_{DDO}	Output Supply Voltage		1.6	1.8	2.0	V
I_{DD}	Power Supply Current	ENABLE [1:2] = 00			8	mA
I_{DDO}	Output Supply Current	ENABLE [1:2] = 00			3	mA

Table 4G. LVCMOS/LVTTL DC Characteristics, $T_A = 0^\circ\text{C}$ to 70°C

Symbol	Parameter		Test Conditions	Minimum	Typical	Maximum	Units
V_{IH}	Input High Voltage	ENABLE1, ENABLE2	$V_{DD} = 3.3V \pm 5\%$	2		$V_{DD} + 0.3$	V
			$V_{DD} = 2.5V \pm 5\%$	1.7		$V_{DD} + 0.3$	V
			$V_{DD} = 1.8V \pm 0.2V$	$0.65 * V_{DD}$		$V_{DD} + 0.3$	V
V_{IL}	Input Low Voltage	ENABLE1, ENABLE2	$V_{DD} = 3.3V \pm 5\%$	-0.3		0.8	V
			$V_{DD} = 2.5V \pm 5\%$	-0.3		0.7	V
			$V_{DD} = 1.8V \pm 0.2V$	-0.3		$0.35 * V_{DD}$	V
V_{OH}	Output High Voltage		$V_{DDO} = 3.3V \pm 5\%$; NOTE 1	2.6			V
			$V_{DDO} = 2.5V \pm 5\%$; $I_{OH} = -1\text{mA}$	2.0			V
			$V_{DDO} = 2.5V \pm 5\%$; NOTE 1	1.8			V
			$V_{DDO} = 1.8V \pm 0.2V$; NOTE 1	$V_{DDO} - 0.3$			V
V_{OL}	Output Low Voltage; NOTE 1		$V_{DDO} = 3.3V \pm 5\%$; NOTE 1			0.5	V
			$V_{DDO} = 2.5V \pm 5\%$; $I_{OL} = 1\text{mA}$			0.4	V
			$V_{DDO} = 2.5V \pm 5\%$; NOTE 1			0.45	V
			$V_{DDO} = 1.8V \pm 0.2V$; NOTE 1			0.35	V

NOTE 1: Outputs terminated with 50Ω to $V_{DDO}/2$. See Parameter Measurement Information, *Output Load Test Circuit diagrams*.

Table 5. Crystal Characteristics

Parameter	Test Conditions	Minimum	Typical	Maximum	Units
Mode of Oscillation		Fundamental			
Frequency		10		40	MHz
Equivalent Series Resistance (ESR)				50	Ω
Shunt Capacitance				7	pF
Drive Level				1	mW

AC Electrical Characteristics

Table 6A. AC Characteristics, $V_{DD} = V_{DDO} = 3.3V \pm 5\%$, $T_A = 0^\circ C$ to $70^\circ C$

Symbol	Parameter	Test Conditions	Minimum	Typical	Maximum	Units
f_{MAX}	Output Frequency	Using External Crystal	10		40	MHz
		Using External Clock Source NOTE 1	DC		100	MHz
$t_{sk(o)}$	Output Skew; NOTE 2, 3				80	ps
$t_{jit}(\emptyset)$	RMS Phase Jitter (Random); NOTE 4	25MHz, Integration Range: 100Hz – 1MHz		0.13		ps
t_R / t_F	Output Rise/Fall Time	20% to 80%	200		800	ps
odc	Output Duty Cycle		48		52	%
t_{EN}	Output Enable Time; NOTE 5	ENABLE1			4	cycles
		ENABLE2			4	cycles
t_{DIS}	Output Disable Time; NOTE 5	ENABLE1			4	cycles
		ENABLE2			4	cycles

NOTE: Electrical parameters are guaranteed over the specified ambient operating temperature range, which is established when the device is mounted in a test socket with maintained transverse airflow greater than 500 lfpm. The device will meet specifications after thermal equilibrium has been reached under these conditions.

All parameters measured at $f \leq f_{MAX}$ using a crystal input unless noted otherwise.

Terminated at 50Ω to $V_{DDO}/2$.

NOTE 1: XTAL_IN can be overdriven by a single-ended LVCMOS signal. Please refer to Application Information section.

NOTE 2: Defined as skew between outputs at the same supply voltage and with equal load conditions. Measured at $V_{DDO}/2$.

NOTE 3: This parameter is defined in accordance with JEDEC Standard 65.

NOTE 4: See phase noise plot.

NOTE 5: These parameters are guaranteed by characterization. Not tested in production.

Table 6B. AC Characteristics, $V_{DD} = V_{DDO} = 2.5V \pm 5\%$, $T_A = 0^\circ C$ to $70^\circ C$

Symbol	Parameter	Test Conditions	Minimum	Typical	Maximum	Units
f_{MAX}	Output Frequency	Using External Crystal	10		40	MHz
		Using External Clock Source NOTE 1	DC		100	MHz
$t_{sk(o)}$	Output Skew; NOTE 2, 3				80	ps
t_{jit}	RMS Phase Jitter (Random); NOTE 4	25MHz, Integration Range: 100Hz – 1MHz		0.26		ps
t_R / t_F	Output Rise/Fall Time	20% to 80%	200		800	ps
odc	Output Duty Cycle		47		53	%
t_{EN}	Output Enable Time; NOTE 5	ENABLE1			4	cycles
		ENABLE2			4	cycles
t_{DIS}	Output Disable Time; NOTE 5	ENABLE1			4	cycles
		ENABLE2			4	cycles

NOTE: Electrical parameters are guaranteed over the specified ambient operating temperature range, which is established when the device is mounted in a test socket with maintained transverse airflow greater than 500 lfpm. The device will meet specifications after thermal equilibrium has been reached under these conditions.

All parameters measured at $f \leq f_{MAX}$ using a crystal input unless noted otherwise.

Terminated at 50Ω to $V_{DDO}/2$.

NOTE 1: XTAL_IN can be overdriven by a single-ended LVCMOS signal. Please refer to Application Information section.

NOTE 2: Defined as skew between outputs at the same supply voltage and with equal load conditions. Measured at $V_{DDO}/2$.

NOTE 3: This parameter is defined in accordance with JEDEC Standard 65.

NOTE 4: See phase noise plot.

NOTE 5: These parameters are guaranteed by characterization. Not tested in production.

Table 6C. AC Characteristics, $V_{DD} = V_{DDO} = 1.8V \pm 0.2V$, $T_A = 0^\circ C$ to $70^\circ C$

Symbol	Parameter		Test Conditions	Minimum	Typical	Maximum	Units
f_{MAX}	Output Frequency	Using External Crystal		10		40	MHz
		Using External Clock Source NOTE 1		DC		100	MHz
$t_{sk(o)}$	Output Skew; NOTE 2, 3					80	ps
$t_{jit}(\emptyset)$	RMS Phase Jitter (Random)		25MHz, Integration Range: 100Hz – 1MHz		0.27		ps
t_R / t_F	Output Rise/Fall Time		20% to 80%	200		900	ps
odc	Output Duty Cycle			47		53	%
t_{EN}	Output Enable Time; NOTE 4	ENABLE1				4	cycles
		ENABLE2				4	cycles
t_{DIS}	Output Disable Time; NOTE 4	ENABLE1				4	cycles
		ENABLE2				4	cycles

NOTE: Electrical parameters are guaranteed over the specified ambient operating temperature range, which is established when the device is mounted in a test socket with maintained transverse airflow greater than 500 lfm. The device will meet specifications after thermal equilibrium has been reached under these conditions.

All parameters measured at $f \leq f_{MAX}$ using a crystal input unless noted otherwise.

Terminated at 50Ω to $V_{DDO}/2$.

NOTE 1: XTAL_IN can be overdriven by a single-ended LVCMOS signal. Please refer to Application Information section.

NOTE 2: Defined as skew between outputs at the same supply voltage and with equal load conditions. Measured at $V_{DDO}/2$.

NOTE 3: This parameter is defined in accordance with JEDEC Standard 65.

NOTE 4: These parameters are guaranteed by characterization. Not tested in production.

Table 6D. AC Characteristics, $V_{DD} = 3.3V \pm 5\%$, $V_{DDO} = 2.5V \pm 5\%$, $T_A = 0^\circ C$ to $70^\circ C$

Symbol	Parameter		Test Conditions	Minimum	Typical	Maximum	Units
f_{MAX}	Output Frequency	Using External Crystal		10		40	MHz
		Using External Clock Source NOTE 1		DC		100	MHz
$t_{sk(o)}$	Output Skew; NOTE 2, 3					80	ps
t_{jit}	RMS Phase Jitter (Random)		25MHz, Integration Range: 100Hz – 1MHz		0.14		ps
t_R / t_F	Output Rise/Fall Time		20% to 80%	200		800	ps
odc	Output Duty Cycle			48		52	%
t_{EN}	Output Enable Time; NOTE 4	ENABLE1				4	cycles
		ENABLE2				4	cycles
t_{DIS}	Output Disable Time; NOTE 4	ENABLE1				4	cycles
		ENABLE2				4	cycles

NOTE: Electrical parameters are guaranteed over the specified ambient operating temperature range, which is established when the device is mounted in a test socket with maintained transverse airflow greater than 500 lfm. The device will meet specifications after thermal equilibrium has been reached under these conditions.

All parameters measured at $f \leq f_{MAX}$ using a crystal input unless noted otherwise.

Terminated at 50Ω to $V_{DDO}/2$.

NOTE 1: XTAL_IN can be overdriven by a single-ended LVCMOS signal. Please refer to Application Information section.

NOTE 2: Defined as skew between outputs at the same supply voltage and with equal load conditions. Measured at $V_{DDO}/2$.

NOTE 3: This parameter is defined in accordance with JEDEC Standard 65.

NOTE 4: These parameters are guaranteed by characterization. Not tested in production.

Table 6E. AC Characteristics, $V_{DD} = 3.3V \pm 5\%$, $V_{DDO} = 1.8V \pm 0.2V$, $T_A = 0^\circ C$ to $70^\circ C$

Symbol	Parameter		Test Conditions	Minimum	Typical	Maximum	Units
f_{MAX}	Output Frequency	Using External Crystal		10		40	MHz
		Using External Clock Source NOTE 1		DC		100	MHz
$t_{sk(o)}$	Output Skew; NOTE 2, 3					80	ps
t_{jit}	RMS Phase Jitter (Random)		25MHz, Integration Range: 100Hz – 1MHz		0.18		ps
t_R / t_F	Output Rise/Fall Time		20% to 80%	200		900	ps
odc	Output Duty Cycle			48		52	%
t_{EN}	Output Enable Time; NOTE 4	ENABLE1				4	cycles
		ENABLE2				4	cycles
t_{DIS}	Output Disable Time; NOTE 4	ENABLE1				4	cycles
		ENABLE2				4	cycles

NOTE: Electrical parameters are guaranteed over the specified ambient operating temperature range, which is established when the device is mounted in a test socket with maintained transverse airflow greater than 500 lfpm. The device will meet specifications after thermal equilibrium has been reached under these conditions.

All parameters measured at $f \leq f_{MAX}$ using a crystal input unless noted otherwise.

Terminated at 50Ω to $V_{DDO}/2$.

NOTE 1: XTAL_IN can be overdriven by a single-ended LVCMOS signal. Please refer to Application Information section.

NOTE 2: Defined as skew between outputs at the same supply voltage and with equal load conditions. Measured at $V_{DDO}/2$.

NOTE 3: This parameter is defined in accordance with JEDEC Standard 65.

NOTE 4: These parameters are guaranteed by characterization. Not tested in production.

Table 6F. AC Characteristics, $V_{DD} = 2.5V \pm 5\%$, $V_{DDO} = 1.8V \pm 0.2V$, $T_A = 0^\circ C$ to $70^\circ C$

Symbol	Parameter		Test Conditions	Minimum	Typical	Maximum	Units
f_{MAX}	Output Frequency	Using External Crystal		10		40	MHz
		Using External Clock Source NOTE 1		DC		100	MHz
$t_{sk(o)}$	Output Skew; NOTE 2, 3					80	ps
t_{jit}	RMS Phase Jitter (Random)		25MHz, Integration Range: 100Hz – 1MHz		0.19		ps
t_R / t_F	Output Rise/Fall Time		20% to 80%	200		900	ps
odc	Output Duty Cycle			47		53	%
t_{EN}	Output Enable Time; NOTE 4	ENABLE1				4	cycles
		ENABLE2				4	cycles
t_{DIS}	Output Disable Time; NOTE 4	ENABLE1				4	cycles
		ENABLE2				4	cycles

NOTE: Electrical parameters are guaranteed over the specified ambient operating temperature range, which is established when the device is mounted in a test socket with maintained transverse airflow greater than 500 lfpm. The device will meet specifications after thermal equilibrium has been reached under these conditions.

All parameters measured at $f \leq f_{MAX}$ using a crystal input unless noted otherwise.

Terminated at 50Ω to $V_{DDO}/2$.

NOTE 1: XTAL_IN can be overdriven by a single-ended LVCMOS signal. Please refer to Application Information section.

NOTE 2: Defined as skew between outputs at the same supply voltage and with equal load conditions. Measured at $V_{DDO}/2$.

NOTE 3: This parameter is defined in accordance with JEDEC Standard 65.

NOTE 4: These parameters are guaranteed by characterization. Not tested in production.

Typical Phase Noise at 25MHz (2.5V Core/2.5V Output)

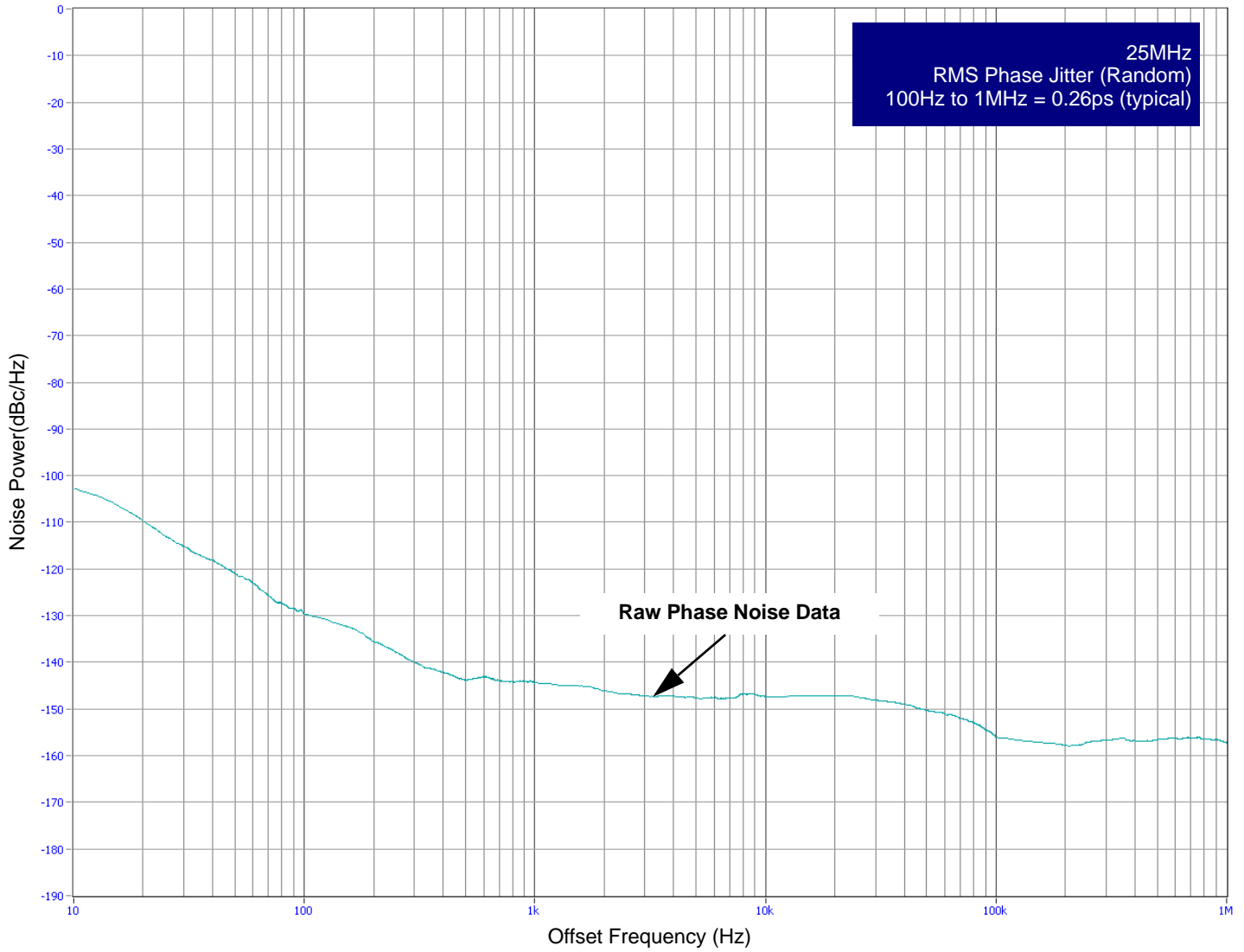

Parameter Measurement Information

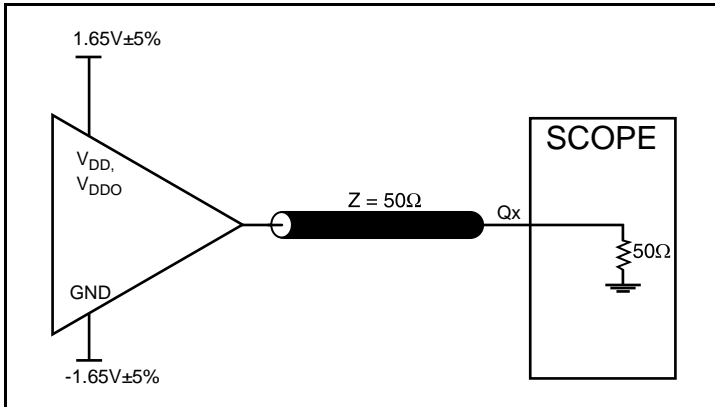

3.3V Core/3.3V LVCMOS Output Load AC Test Circuit

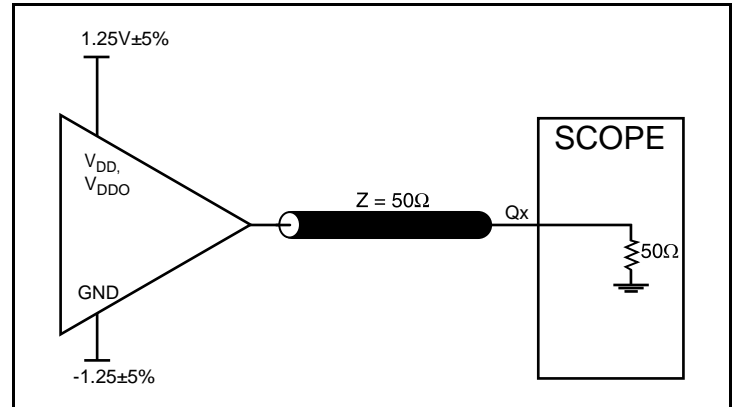

2.5V Core/2.5V LVCMOS Output Load AC Test Circuit

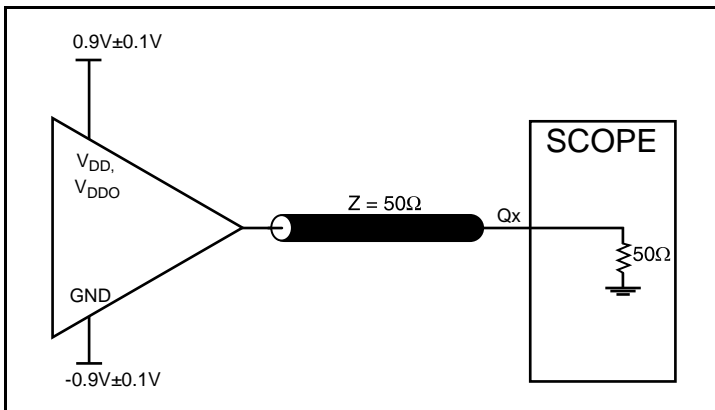

1.8V Core/1.8V LVCMOS Output Load AC Test Circuit

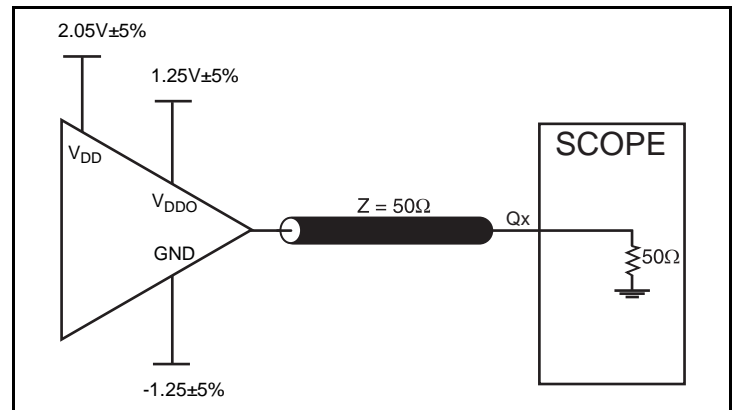

3.3V Core/2.5V LVCMOS Output Load AC Test Circuit

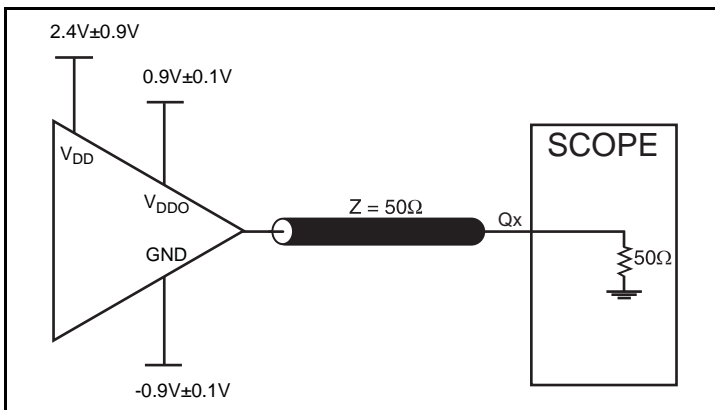

3.3V Core/1.8V LVCMOS Output Load AC Test Circuit

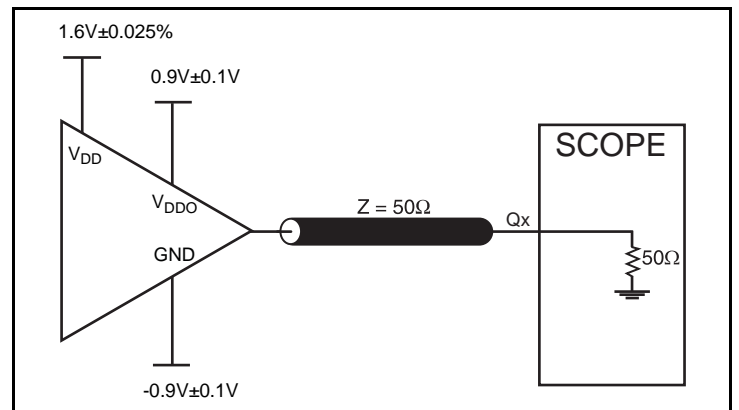

2.5V Core/1.8V LVCMOS Output Load AC Test Circuit

Parameter Measurement Information, continued

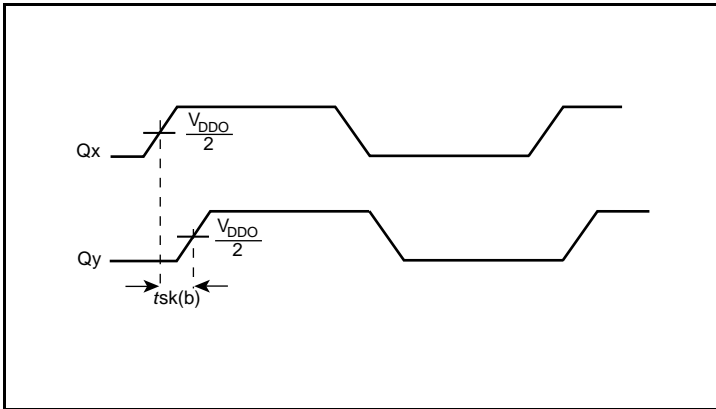

Output Skew

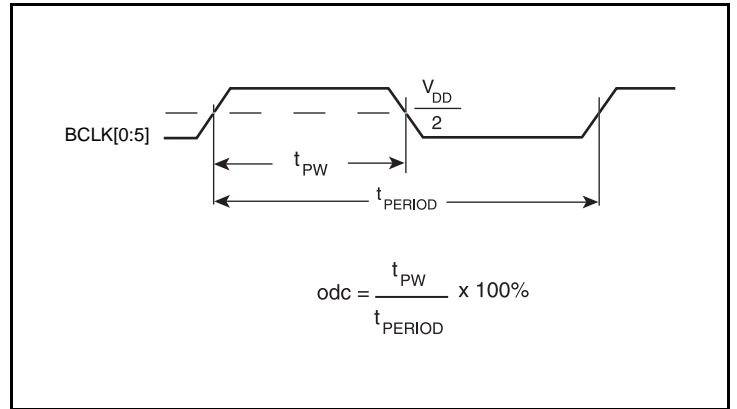

Output Duty Cycle/Pulse Width/Period

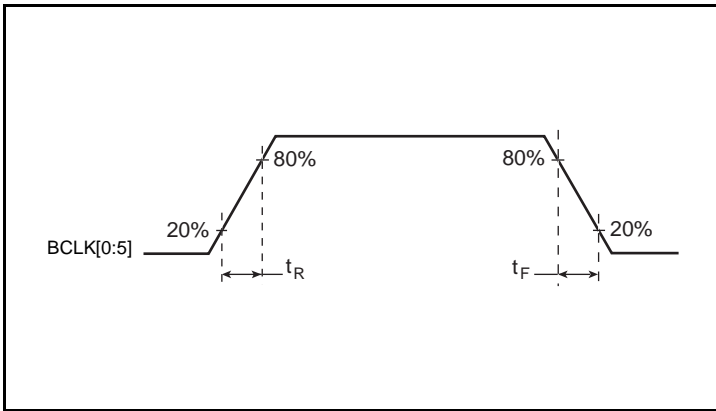

Output Rise/Fall Time

Application Information

Crystal Input Interface

Figure 2 shows an example of 83905 crystal interface with a parallel resonant crystal. The frequency accuracy can be fine tuned by adjusting the C1 and C2 values. For a parallel crystal with loading capacitance $C_L = 18\text{pF}$, to start with, we suggest $C_1 = 15\text{pF}$ and $C_2 = 15\text{pF}$. These values may be slightly fine tuned further to optimize the frequency accuracy for different board

layouts. Slightly increasing the C1 and C2 values will slightly reduce the frequency. Slightly decreasing the C1 and C2 values will slightly increase the frequency. For the oscillator circuit below, R1 can be used, but is not required. For new designs, it is recommended that R1 not be used.

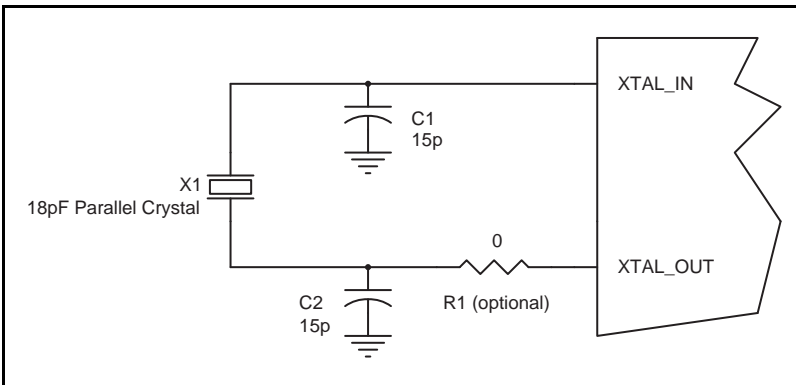

Figure 2. Crystal Input Interface

LVC MOS to XTAL Interface

The XTAL_IN input can accept a single-ended LVC MOS signal through an AC coupling capacitor. A general interface diagram is shown in Figure 3. The XTAL_OUT pin can be left floating. The input edge rate can be as slow as 10ns. For LVC MOS inputs, it is recommended that the amplitude be reduced from full swing to half swing in order to prevent signal interference with the power rail and to reduce noise. This configuration requires that the output impedance of the driver (R_o) plus the series resistance (R_s) equals

the transmission line impedance. In addition, matched termination at the crystal input will attenuate the signal in half. This can be done in one of two ways. First, R1 and R2 in parallel should equal the transmission line impedance. For most 50Ω applications, R1 and R2 can be 100Ω. This can also be accomplished by removing R1 and making R2 50Ω. By overdriving the crystal oscillator, the device will be functional, but note, the device performance is guaranteed by using a quartz crystal.

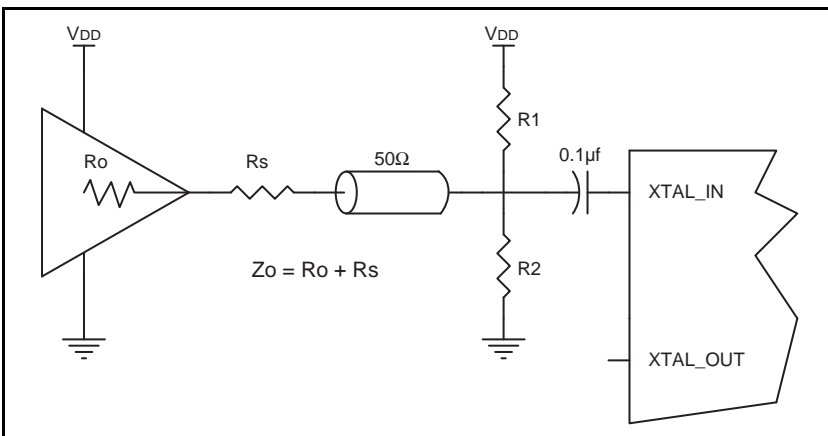

Figure 3. General Diagram for LVC MOS Driver to XTAL Input Interface

VFQFN EPAD Thermal Release Path

In order to maximize both the removal of heat from the package and the electrical performance, a land pattern must be incorporated on the Printed Circuit Board (PCB) within the footprint of the package corresponding to the exposed metal pad or exposed heat slug on the package, as shown in *Figure 4*. The solderable area on the PCB, as defined by the solder mask, should be at least the same size/shape as the exposed pad/slug area on the package to maximize the thermal/electrical performance. Sufficient clearance should be designed on the PCB between the outer edges of the land pattern and the inner edges of pad pattern for the leads to avoid any shorts.

While the land pattern on the PCB provides a means of heat transfer and electrical grounding from the package to the board through a solder joint, thermal vias are necessary to effectively conduct from the surface of the PCB to the ground plane(s). The land pattern must be connected to ground through these vias. The vias act as “heat pipes”. The number of vias (i.e. “heat pipes”) are

application specific and dependent upon the package power dissipation as well as electrical conductivity requirements. Thus, thermal and electrical analysis and/or testing are recommended to determine the minimum number needed. Maximum thermal and electrical performance is achieved when an array of vias is incorporated in the land pattern. It is recommended to use as many vias connected to ground as possible. It is also recommended that the via diameter should be 12 to 13mils (0.30 to 0.33mm) with 1oz copper via barrel plating. This is desirable to avoid any solder wicking inside the via during the soldering process which may result in voids in solder between the exposed pad/slug and the thermal land. Precautions should be taken to eliminate any solder voids between the exposed heat slug and the land pattern. Note: These recommendations are to be used as a guideline only. For further information, please refer to the Application Note on the Surface Mount Assembly of Amkor’s Thermally/Electrically Enhance Leadframe Base Package, Amkor Technology.

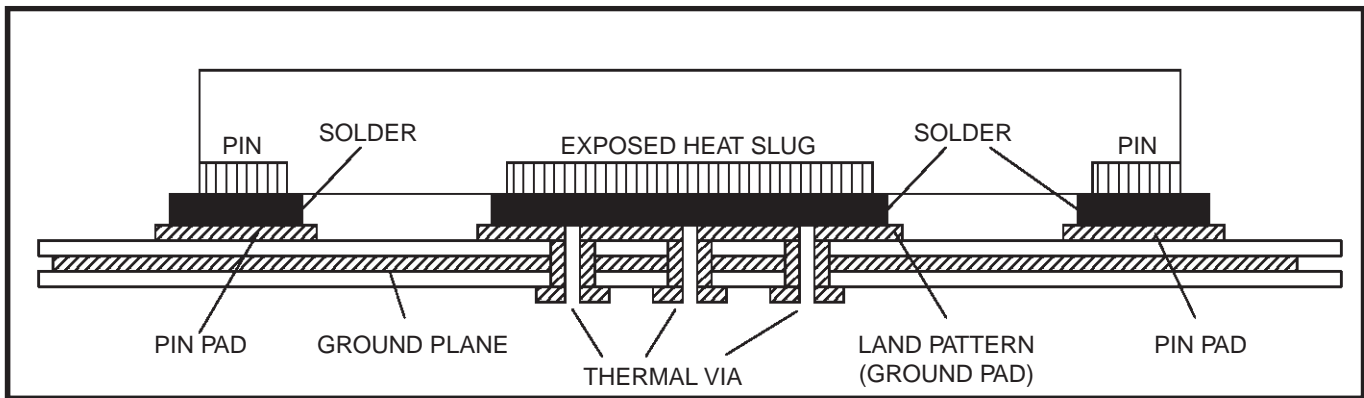

Figure 4. P.C. Assembly for Exposed Pad Thermal Release Path – Side View (drawing not to scale)

Recommendations for Unused Input and Output Pins

Inputs:

LVC MOS Control Pins

All control pins have internal pull-ups or pull-downs; additional resistance is not required but can be added for additional protection. A 1kΩ resistor can be used.

Outputs:

LVC MOS Outputs

All unused LVC MOS output can be left floating. There should be no trace attached.

Layout Guideline

Figure 5 shows an example of 83905 application schematic. The schematic example focuses on functional connections and is not configuration specific. In this example, the device is operated at $V_{DD} = 3.3V$ and $V_{DDO} = 1.8V$. The crystal inputs are loaded with an 18pF load resonant quartz crystal. The tuning capacitors (C1, C2) are fairly accurate, but minor adjustments might be required. Refer to the pin description and functional tables in the datasheet to ensure the logic control inputs are properly set. For the LVCMOS output drivers, two termination examples are shown in the schematic. For additional termination examples are shown in the LVCMOS Termination Application Note.

As with any high speed analog circuitry, the power supply pins are vulnerable to random noise. To achieve optimum jitter performance, power supply isolation is required. The 83905 provides separate V_{DD} and V_{DDO} power supplies to isolate any high switching noise from coupling into the internal oscillator. In order to achieve the best possible filtering, it is highly

recommended that the 0.1uF capacitors on the device side of the ferrite beads be placed on the device side of the PCB as close to the power pins as possible. This is represented by the placement of these capacitors in the schematic. If space is limited, the ferrite beads, 10uF and 0.1uF capacitor connected to the board supplies can be placed on the opposite side of the PCB. If space permits, place all filter components on the device side of the board.

Power supply filter recommendations are a general guideline to be used for reducing external noise from coupling into the devices. The filter performance is designed for a wide range of noise frequencies. This low-pass filter starts to attenuate noise at approximately 0kHz. If a specific frequency noise component is known, such as switching power supplies frequencies, it is recommended that component values be adjusted and if required, additional filtering be added. Additionally, good general design practices for power plane voltage stability suggests adding bulk capacitance in the local area of all devices.

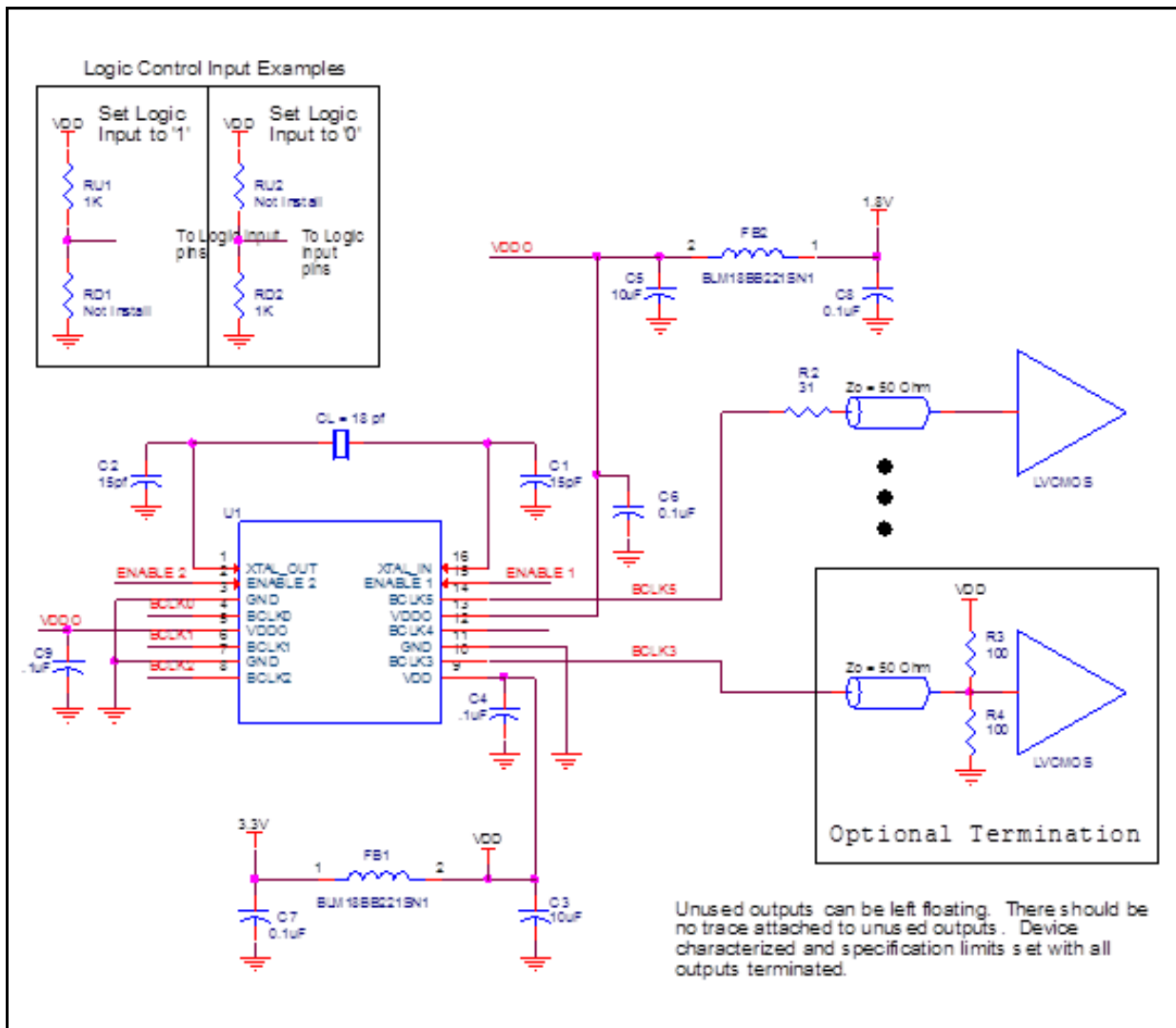

Figure 5. Schematic of Recommended Layout

Power Considerations

This section provides information on power dissipation and junction temperature for the 83905. Equations and example calculations are also provided.

1. Power Dissipation.

The total power dissipation for the 83905 is the sum of the core power plus the analog power plus the power dissipated due to the load. The following is the power dissipation for $V_{DD} = 3.3V + 5\% = 3.465V$, which gives worst case results.

- Power (core)_{MAX} = $V_{DD_MAX} * (I_{DD} + I_{DDO}) = 3.465V * (10mA + 5mA) = \mathbf{51.9mW}$
- Output Impedance R_{OUT} Power Dissipation due to Loading 50Ω to $V_{DD}/2$
Output Current $I_{OUT} = V_{DD_MAX} / [2 * (50\Omega + R_{OUT})] = 3.465V / [2 * (50\Omega + 7\Omega)] = \mathbf{30.4mA}$
- Power Dissipation on the R_{OUT} per LVCMOS output
Power (R_{OUT}) = $R_{OUT} * (I_{OUT})^2 = 7\Omega * (30.4mA)^2 = \mathbf{6.5mW}$ per output
- Total Power Dissipation on the R_{OUT}
Total Power (R_{OUT}) = $6.5mW * 6 = \mathbf{39mW}$

Dynamic Power Dissipation at 25MHz

$$\text{Power (25MHz)} = C_{PD} * \text{Frequency} * (V_{DD})^2 = 19pF * 25MHz * (3.465V)^2 = \mathbf{5.70mW}$$
 per output
Total Power (25MHz) = $5.70mW * 6 = \mathbf{34.2mW}$

Total Power Dissipation

- **Total Power**
= Power (core)_{MAX} + Total Power (R_{OUT}) + Total Power (25MHz)
= $51.98mW + 39mW + 34.2mW$
= **125.1mW**

2. Junction Temperature.

Junction temperature, T_j , is the temperature at the junction of the bond wire and bond pad and directly affects the reliability of the device. The maximum recommended junction temperature is 125°C .

The equation for T_j is as follows: $T_j = \theta_{JA} * Pd_total + T_A$

T_j = Junction Temperature

θ_{JA} = Junction-to-Ambient Thermal Resistance

Pd_total = Total Device Power Dissipation (example calculation is in section 1 above)

T_A = Ambient Temperature

In order to calculate junction temperature, the appropriate junction-to-ambient thermal resistance θ_{JA} must be used. Assuming no air flow and a multi-layer board, the appropriate value is 100.3°C/W per Table 7 below.

Therefore, T_j for an ambient temperature of 70°C with all outputs switching is:

$$70^\circ\text{C} + 0.125W * 100.3^\circ\text{C/W} = 82.5^\circ\text{C}. \text{ This is below the limit of } 125^\circ\text{C}.$$

This calculation is only an example. T_j will obviously vary depending on the number of loaded outputs, supply voltage, air flow and the type of board (multi-layer).

Table 7. Thermal Resistance θ_{JA} for 16-Lead TSSOP, Forced Convection

Meters per Second	θ_{JA} by Velocity		
	0	1	2.5
Multi-Layer PCB, JEDEC Standard Test Boards	100.3°C/W	96.0°C/W	93.9°C/W

Reliability Information

Table 8A. θ_{JA} vs. Air Flow Table for a 16-Lead TSSOP

θ_{JA} vs. Air Flow			
Meters per Second	0	1	2.5
Multi-Layer PCB, JEDEC Standard Test Boards	100.3°C/W	96.0°C/W	93.9°C/W

Table 8B. θ_{JA} vs. Air Flow Table for a 16-Lead SOIC

θ_{JA} vs. Air Flow			
Meters per Second	0	1	2.5
Multi-Layer PCB, JEDEC Standard Test Boards	78.8°C/W	71.1°C/W	66.2°C/W

Table 8C. θ_{JA} vs. Air Flow Table for a 20-Lead VFQFN

θ_{JA} vs. Air Flow			
Meters per Second	0	1	2.5
Multi-Layer PCB, JEDEC Standard Test Boards	57.5°C/W	50.3°C/W	45.1°C/W

Transistor Count

The transistor count for 83905: 339

Package Outline and Package Dimensions

Package Outline - G Suffix for 16-Lead TSSOP

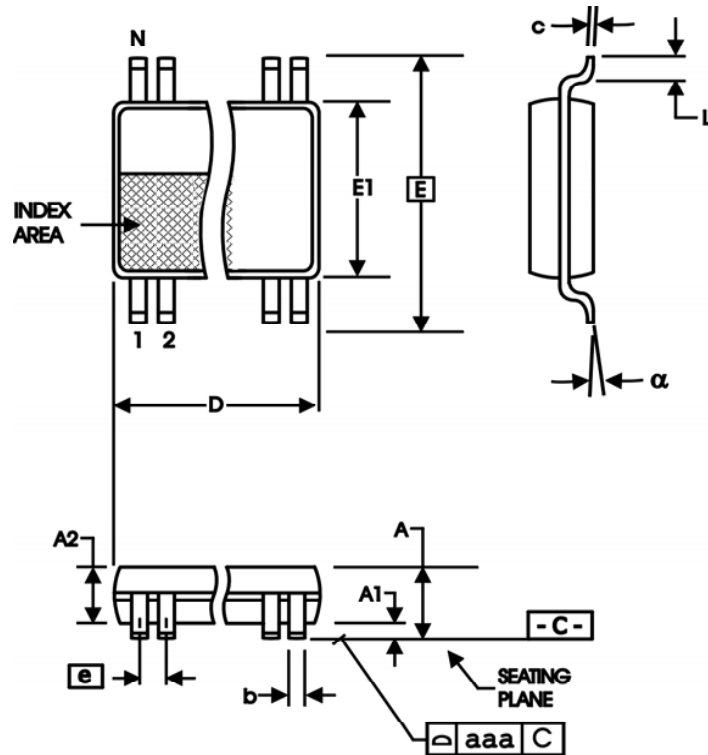

Table 9A. Package Dimensions for 16-Lead TSSOP

All Dimensions in Millimeters		
Symbol	Minimum	Maximum
N	16	
A		1.20
A1	0.05	0.15
A2	0.80	1.05
b	0.19	0.30
c	0.09	0.20
D	4.90	5.10
E	6.40 Basic	
E1	4.30	4.50
e	0.65 Basic	
L	0.45	0.75
α	0°	8°
aaa		0.10

Reference Document: JEDEC Publication 95, MO-153

Package Outline - M Suffix for 16-Lead SOIC

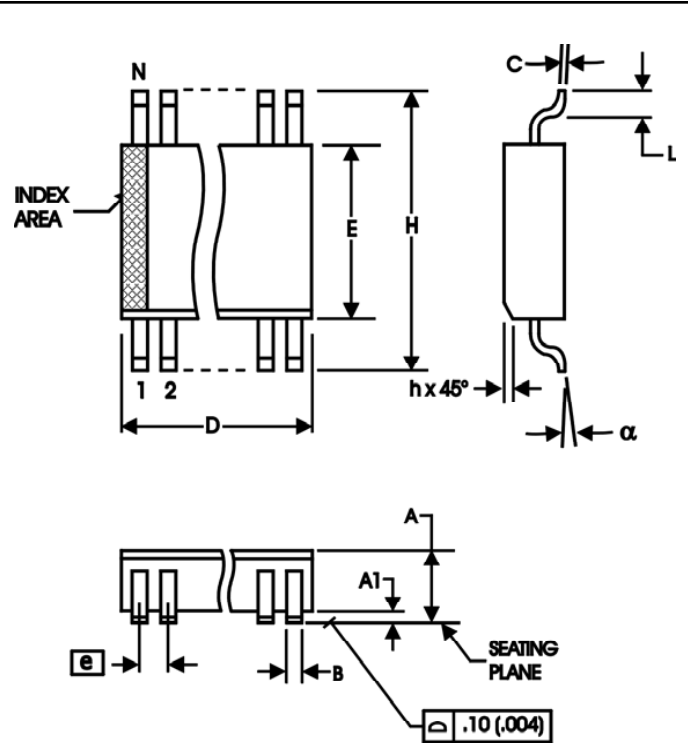

Table 9B. Package Dimensions for 16-Lead SOIC

All Dimensions in Millimeters		
Symbol	Minimum	Maximum
N	16	
A	1.35	1.75
A1	0.10	0.25
B	0.33	0.51
C	0.19	0.25
D	9.80	10.00
E	3.80	4.00
e	1.27 Basic	
H	5.80	6.20
h	0.25	0.50
L	0.40	1.27
α	0°	8°

Reference Document: JEDEC Publication 95, MS-012

Package Outline and Package Dimensions

Package Outline - K Suffix for 20-Lead VFQFN

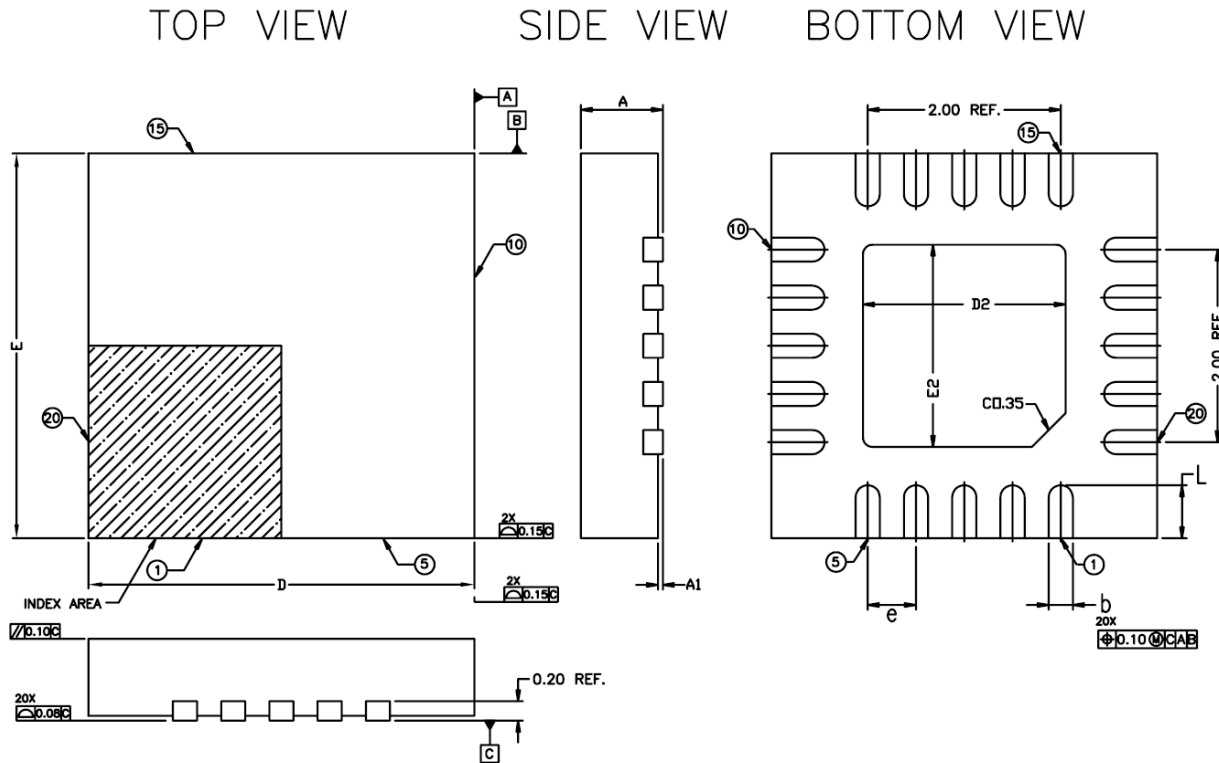

Table 10. Package Dimensions

All Dimensions in Millimeters			
Symbol	Minimum	Nominal	Maximum
N	20		
A	0.80		1.00
A1	0		0.05
A3	0.2 Ref.		
b	0.20	0.25	0.30
N _D & N _E	5		
D & E	4.00 Basic		
D2 & E2	1.95		2.25
e	0.50 Basic		
L	0.45	0.55	0.65

Reference Document: JEDEC Publication 95, MO-220

NOTE:

The drawing and dimension data originate from IDT package outline drawing PSC-4170, rev03.

1. Dimensions and tolerances conform to ASME Y14.5M-1994
2. All dimensions are in millimeters. All angles are in degrees.
3. N is the total number of terminals.
4. All specifications comply with JEDEC MO-220.

Ordering Information

Table 11. Ordering Information

Part/Order Number	Marking	Package	Shipping Packaging	Temperature
83905AMLF	83905AML	"Lead-Free" 16-Lead SOIC	Tube	0°C to 70°C
83905AMLFT	83905AML	"Lead-Free" 16-Lead SOIC	Tape & Reel	0°C to 70°C
83905AGLF	83905AGL	"Lead-Free" 16-Lead TSSOP	Tube	0°C to 70°C
83905AGLFT	83905AGL	"Lead-Free" 16-Lead TSSOP	Tape & Reel	0°C to 70°C
83905AKLF	3905AL	"Lead-Free" 20-Lead VFQFN	Tray	0°C to 70°C
83905AKLFT	3905AL	"Lead-Free" 20-Lead VFQFN	Tape & Reel	0°C to 70°C

Revision History Sheet

Rev	Table	Page	Description of Change	Date
A		2	Added Enable Timing Diagram.	3/28/05
B	T6A - T6F	1 5 - 7 8	Features Section - added RMS Phase Jitter bullet. AC Characteristics Tables - added RMS Phase Jitter specs. Added Phase Noise Plot.	4/8/05
B	T9	14	Ordering Information Table - added TSSOP, non-LF part number.	4/25/05
B		11 12	Added Crystal Input Interface in Application Section. Added Schematic layout.	5/16/05
B		3 11 13	Absolute Maximum Ratings - corrected 20-Lead VFQFN package Thermal Impedance. Added Recommendations for <i>Unused Input and Output Pins</i> . Corrected Theta JA Air Flow Table for 20-Lead VFQFN.	10/2/06
B	T9	11 12 17	Added <i>LVC MOS to XTAL Interface</i> section. Added <i>Thermal Release Path</i> section. AC Characteristics Table - added lead-free marking for 20-Lead VFQFN package.	7/9/07
B	T7B - T7C	3 12 14 16	Absolute Maximum Ratings - updated TSSOP and VFQFN Thermal Impedance. Updated Thermal Release Path section. Updated TSSOP and VFQFN Thermal Impedance. Added note to VFQFN Package Outline.	1/24/08
B		15	Added Power Considerations section. Converted datasheet format.	7/20/09
B	T10	19	Removed leaded order-able parts from Ordering Information table	11/14/12
C	T6D T9A T11	1, 15 1 7 14 17 18 19	Deleted HiPerClockS references. Features, last bullet: updated packaging note. Mixed AC Characteristics Table - corrected typo, switched <i>Output Rise/Fall Time spec</i> with <i>Output Duty Cycle spec</i> . Replaced schematic. 16-Lead TSSOP Package Table - corrected dimension A1 Minimum = 0.05. Updated VFQFN package outline page. Ordering Information table - deleted Lead-free note, and quantity from Tape and Reel.	4/18/13
C		1	Pin Assignment: Corrected 20-Lead illustration cut-off text	2/27/14
C	T6A - T6F T10	1 6 - 8 9 11 18 21	Pin Assignment, 20-Lead VFQFN: removed the Epad dimensions. Changed NOTE 1 to XTAL_IN can be overdriven by a single-ended LVC MOS signal. Please refer to Application Information section. Deleted 3.3V Phase Noise Plot Deleted RMS Phase Jitter graph. Modified dimensions to reflect tightened tolerances. Updated contact information.	8/6/14
D		2	Figure 1 corrected. Updated datasheet header/footer. Deleted "ICS" prefix from part number throughout the datasheet	9/27/16



Corporate Headquarters
6024 Silver Creek Valley Road
San Jose, CA 95138 USA
www.IDT.com

Sales
1-800-345-7015 or 408-284-8200
Fax: 408-284-2775
www.IDT.com/go/sales

Tech Support
www.IDT.com/go/support

DISCLAIMER Integrated Device Technology, Inc. (IDT) reserves the right to modify the products and/or specifications described herein at any time, without notice, at IDT's sole discretion. Performance specifications and operating parameters of the described products are determined in an independent state and are not guaranteed to perform the same way when installed in customer products. The information contained herein is provided without representation or warranty of any kind, whether express or implied, including, but not limited to, the suitability of IDT's products for any particular purpose, an implied warranty of merchantability, or non-infringement of the intellectual property rights of others. This document is presented only as a guide and does not convey any license under intellectual property rights of IDT or any third parties.

IDT's products are not intended for use in applications involving extreme environmental conditions or in life support systems or similar devices where the failure or malfunction of an IDT product can be reasonably expected to significantly affect the health or safety of users. Anyone using an IDT product in such a manner does so at their own risk, absent an express, written agreement by IDT.

Integrated Device Technology, IDT and the IDT logo are trademarks or registered trademarks of IDT and its subsidiaries in the United States and other countries. Other trademarks used herein are the property of IDT or their respective third party owners. For datasheet type definitions and a glossary of common terms, visit www.idt.com/go/glossary. Integrated Device Technology, Inc.. All rights reserved.

Looking for pricing, stock, or lifecycle information?

Click below to explore more details on WIN SOURCE:

- ⊖ [View 83905AGLFT on WIN SOURCE](#)
- ⊖ [IDT, Integrated Device Technology Inc Information](#)

Optimize Your Supply Chain with WIN SOURCE Solutions

- ✓ Global Sourcing Solution
- ✓ Obsolete Management
- ✓ Cost Control Management
- ✓ Shortage Management
- ✓ Alternative Solution
- ✓ Excess Inventory Management