



# THE DATASHEET OF ONET1141LRGER



## 11.3 Gbps Modulator Driver

Check for Samples: [ONET1141L](#)

### FEATURES

- Digitally Selectable Output Amplitude up to 2.0VPP Single-Ended
- Digitally Selectable Bias Current up to 145mA Source
- 2-wire Digital Interface with Integrated DACs and ADC for Control and Diagnostic Management
- Automatic Power Control (APC) Loop
- Adjustable Rise and Fall Times
- Programmable Input Equalizer
- Cross-Point Control
- Selectable Monitor PD Current Range and Polarity

- Includes Laser Safety Features
- Single 3.3V Supply
- –40°C to 100°C Operation
- Surface Mount Small Footprint 4mm x 4mm 24 Pin RoHS Compliant QFN Package

### APPLICATIONS

- 10 Gigabit Ethernet Optical Transmitters
- SONET OC-192/SDH STM-64 Optical Transmitters
- 10G-EPON and XG-PON
- SFP+ and XFP Transceiver Modules
- XENPAK, XPAK, X2 and 300-pin MSA Transponder Modules

### DESCRIPTION

The ONET1141L is a high-speed, 3.3V electroabsorption modulator driver designed to bias and modulate an electroabsorptive modulated laser (EML) at data rates from 1 Gbps up to 11.3 Gbps.

The device provides a two-wire serial interface which allows digital control of the modulation and bias currents, eliminating the need for external components. Output waveform control, in the form of cross-point adjustment and rise and fall time adjustment are available to improve the optical eye mask margin. An optional input equalizer can be used for equalization of up to 150mm (6") of microstrip or stripline transmission line on FR4 printed circuit boards. The device contains internal analog to digital and digital to analog converters to eliminate the need for special purpose microcontrollers.

The ONET1141L includes an integrated automatic power control (APC) loop which compensates for variations in laser average optical power over voltage and temperature and circuitry to support laser safety and transceiver management systems.

The modulator driver is characterized for operation from –40°C to 100°C case temperatures and is available in a small footprint 4mm x 4mm 24 pin RoHS compliant QFN package.



Please be aware that an important notice concerning availability, standard warranty, and use in critical applications of Texas Instruments semiconductor products and disclaimers thereto appears at the end of this data sheet.



These devices have limited built-in ESD protection. The leads should be shorted together or the device placed in conductive foam during storage or handling to prevent electrostatic damage to the MOS gates.

## BLOCK DIAGRAM

A simplified block diagram of the ONET1141L is shown in Figure 1. The modulator driver consists of an input equalizer with selectable bypass, a limiter, an output driver, DC offset cancellation with cross point control, power-on reset circuitry, a 2-wire serial interface including a control logic block, a modulation current generator, a bias current generator with automatic power control loop, an analog to digital converter and an analog reference block.

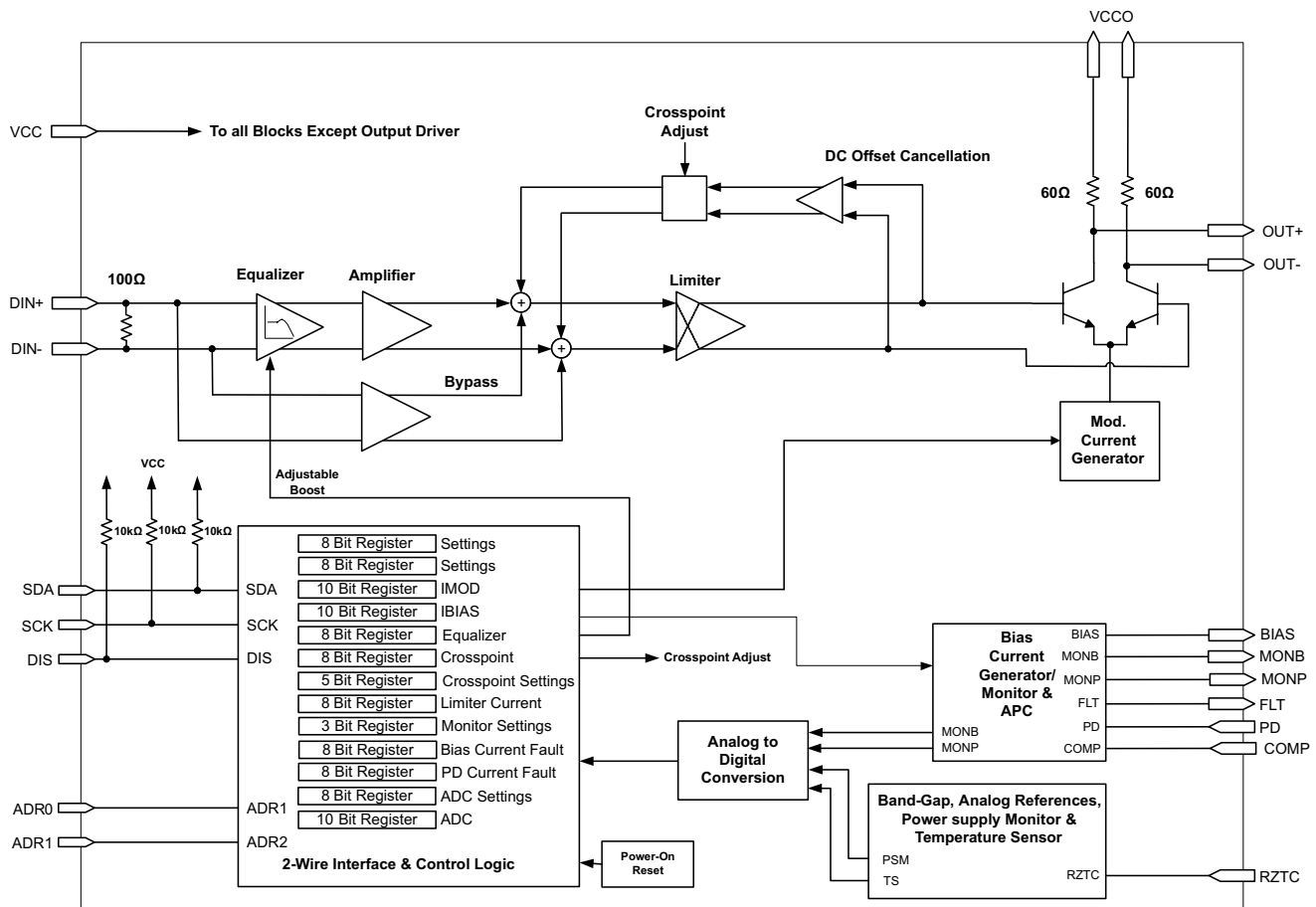

**Figure 1. Simplified Block Diagram of the ONET1141L**

## PACKAGE

The ONET1141L is packaged in a small footprint 4mm X 4mm 24 pin RoHS compliant QFN package with a lead pitch of 0.5mm. The pin out is shown below.

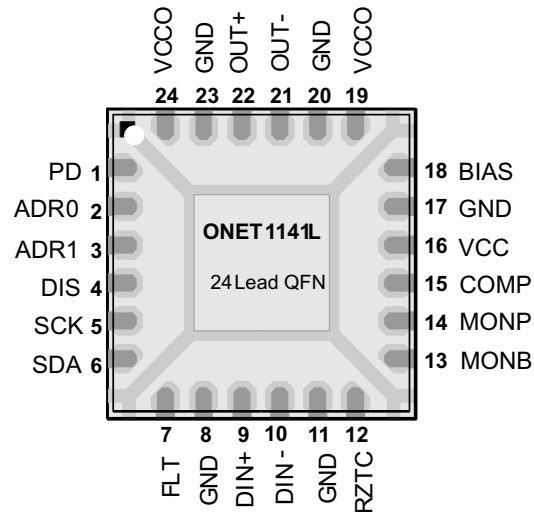
**24 PIN QFN PACKAGE, 4mm x 4mm  
(TOP VIEW)**

**PIN FUNCTIONS**

NO.		TYPE	DESCRIPTION
PIN	NAME		
1	PD	Analog	Photodiode input. Pin can source or sink current dependent on register setting.
2	ADR0	Digital-in	2-wire interface address programming pin. Leave this pad open for a default address of 0001000. Pulling the pin to VCC changes the 1 <sup>st</sup> address bit to a 1 (address = 0001001)
3	ADR1	Digital-in	2-wire interface address programming pin. Leave this pad open for a default address of 0001000. Pulling the pin to VCC changes the 2 <sup>nd</sup> address bit to a 1 (address = 0001010)
4	DIS	Digital-in	Disables both bias and modulation currents when set to high state. Includes a 10kΩ or 40kΩ pull-up resistor to VCC. Toggle to reset a fault condition.
5	SCK	Digital-in	2-wire interface serial clock input. Includes a 10kΩ or 40kΩ pull-up resistor to VCC.
6	SDA	Digital-in/out	2-wire interface serial data input/output. Includes a 10kΩ or 40kΩ pull-up resistor to VCC.
7	FLT	Digital-out	Fault detection flag. High level indicates that a fault has occurred. Open drain output. Requires an external 4.7kΩ to 10kΩ pull-up resistor to VCC for proper operation.
8, 11, 17, 20, 23, EP	GND	Supply	Circuit ground. Exposed die pad (EP) must be grounded.
9	DIN+	Analog-in	Non-inverted data input. On-chip differentially 100Ω terminated to DIN-. Must be AC coupled.
10	DIN-	Analog-in	Inverted data input. On-chip differentially 100Ω terminated to DIN+. Must be AC coupled.
12	RZTC	Analog	Connect external zero TC 28.7kΩ resistor to ground (GND). Used to generate a defined zero TC reference current for internal DACs.
13	MONB	Analog-out	Bias current monitor. Sources a 1% replica of the bias current. Connect an external resistor to ground (GND) to use the analog monitor (DMONB = 0). If the voltage at this pin exceeds 1.16V a fault is triggered. Typically choose a resistor to give MONB voltage of 0.8V at the maximum desired bias current. If the digital monitor function is used (DMONB = 1) the resistor must be removed.
14	MONP	Analog-out	Photodiode current monitor. Sources a 12.5% replica of the photodiode current when PDRNG = 1X, a 25% replica when PDRNG = 01 and a 50% replica when PDRNG = 00. Connect an external resistor (5kΩ typical) to ground (GND) to use the analog monitor (DMONP = 0). If the voltage at this pin exceeds 1.16V a fault is triggered when MONPFLT = 1. If the digital monitor function is used (DMONP = 1) the resistor must be removed.
15	COMP	Analog	Compensation pin used to control the bandwidth of the APC loop. Connect a 0.01μF capacitor to ground.
16	VCC	Supply	3.3V ± 10% supply voltage.
18	BIAS	Analog	Sinks or sources the bias current for the laser in both APC and open loop modes.
19, 24	VCCO	Supply	3.3V ± 10% supply voltage for the output stage.
21	OUT-	CML-out	Inverted data output.
22	OUT+	CML-out	Non-inverted data output.

## ABSOLUTE MAXIMUM RATINGS

 over operating free-air temperature range (unless otherwise noted) <sup>(1)</sup>

		VALUE		UNIT
		MIN	MAX	
V <sub>CC</sub>	Supply voltage <sup>(2)</sup>	-0.3	4.0	V
V <sub>ADR0</sub> , V <sub>ADR1</sub> , V <sub>DIS</sub> , V <sub>RZTC</sub> , V <sub>SCK</sub> , V <sub>SDA</sub> , V <sub>DIN+</sub> , V <sub>DIN-</sub> , V <sub>FLT</sub> , V <sub>MONB</sub> , V <sub>MONP</sub> , V <sub>COMP</sub> , V <sub>PD</sub> , V <sub>BIAS</sub> , V <sub>OUT+</sub> , V <sub>OUT-</sub>	Voltage at ADR0, ADR1, DIS, RZTC, SCK, SDA, DIN+, DIN-, FLT, MONB, MONP, COMP, PD, BIAS, OUT+, OUT- <sup>(2)</sup>	-0.3	4.0	V
I <sub>DIN-</sub> , I <sub>DIN+</sub>	Maximum current at input pins		25	mA
I <sub>OUT+</sub> , I <sub>OUT-</sub>	Maximum current at output pins		120	mA
I <sub>BIAS-MAX</sub>	Maximum bias current		180	mA
ESD	ESD rating at all pins		2	kV (HBM)
T <sub>J,max</sub>	Maximum junction temperature		125	°C
T <sub>STG</sub>	Storage temperature range	-65	150	°C
T <sub>C</sub>	Case temperature	-40	110	°C

- (1) Stresses beyond those listed under “absolute maximum ratings” may cause permanent damage to the device. These are stress ratings only, and functional operation of the device at these or any other conditions beyond those indicated under “recommended operating conditions” is not implied. Exposure to absolute–maximum–rated conditions for extended periods may affect device reliability.
- (2) All voltage values are with respect to network ground terminal.

## RECOMMENDED OPERATING CONDITIONS

over operating free-air temperature range (unless otherwise noted)

			MIN	TYP	MAX	UNIT
V <sub>CC</sub>	Supply voltage		2.97	3.3	3.63	V
V <sub>IH</sub>	Digital input high voltage	DIS, SCK, SDA	2.0			V
V <sub>IL</sub>	Digital input low voltage	DIS, SCK, SDA			0.8	V
	Photodiode current range	Control bit PDRNG = 1X, step size = 3 μA		3080		μA
		Control bit PDRNG = 01, step size = 1.5 μA		1540		
		Control bit PDRNG = 00, step size = 0.75 μA		770		
R <sub>RZTC</sub>	Zero TC resistor value <sup>(1)</sup>	1.16V bandgap bias across resistor, E96, 1% accuracy	28.4	28.7	29	kΩ
V <sub>IN</sub>	Differential input voltage swing	EQENA = 1	160		1000	mV <sub>p-p</sub>
		EQENA = 0	400		1000	
t <sub>R-IN</sub>	Input rise time	20%–80%		30	55	ps
t <sub>F-IN</sub>	Input fall time	20%–80%		30	55	ps
T <sub>C</sub>	Temperature at thermal pad		-40		100	°C

- (1) Changing the value will alter the DAC ranges.

## DC ELECTRICAL CHARACTERISTICS

Over recommended operating conditions, with 50Ω output load, open loop operation,  $V_{OUT} = 2.0V_{pp}$ ,  $I_{BIAS} = 80\text{ mA}$ , and  $R_{RZTC} = 28.7k\Omega$  unless otherwise noted. Typical operating condition is at  $V_{CC} = 3.3V$  and  $T_A = 25^\circ C$

PARAMETER	CONDITION	MIN	TYP	MAX	UNIT		
$V_{CC}$	Supply voltage	2.97	3.3	3.63	V		
$I_{VCC}$	Supply current	$V_{OUT} = 2.0V_{pp}$ , $I_{BIAS} = 0\text{mA}$ , $EQENA = 0$		143	170	mA	
		$V_{OUT} = 2.0V_{pp}$ , $I_{BIAS} = 0\text{mA}$ , $EQENA = 1$		151	182		
		Output off (DIS = HIGH), $V_{OUT} = 2.0V_{pp}$ , $I_{BIAS} = 80\text{ mA}$ , $EQENA = 0$		40			
$R_{IN}$	Data input resistance	Differential between DIN+ / DIN-		82	100	118	Ω
$R_{OUT}$	Output resistance	Single-ended at OUT+ or OUT-		50	60	70	Ω
	Digital input current	SCK, SDA, pull up to VCC		2	360	470	μA
	Digital input current	DIS, pull up to VCC		2	360	470	μA
$V_{OH}$	Digital output high voltage	FLT, pull-up to $V_{CC}$ , $I_{SOURCE} = 50\text{ μA}$		2.4			V
$V_{OL}$	Digital output low voltage	FLT, pull-up to $V_{CC}$ , $I_{SINK} = 350\text{ μA}$				0.4	V
$I_{BIAS-MIN}$	Minimum bias current	See (1)				5	mA
$I_{BIAS-MAX}$	Maximum bias current	Source. $BIASPOL = 0$ , DAC set to maximum, open and closed loop		145	160	mA	
		Sink. $BIASPOL = 1$ , DAC set to maximum, open and closed loop		93	105		
$I_{BIAS-DIS}$	Bias current during disable					100	μA
	Average power stability	APC loop enabled		±0.5			dB
	Bias pin compliance voltage	Source. $BIASPOL = 0$		0.9			V
		Sink. $BIASPOL = 1$				$V_{CC}-0.9$	
	Temperature sensor accuracy	With 1-point external mid scale calibration		±3			°C
$V_{PD}$	Photodiode reverse bias voltage	APC active, $I_{PD} = \text{max}$		1.3	2.3		V
	Photodiode fault current level	Percent of target $I_{PD}$ (2)		150%			
	Photodiode current monitor ratio	$I_{MONP} / I_{PD}$ with control bit PDRNG = 1X		10%	12.5%	15%	
		$I_{MONP} / I_{PD}$ with control bit PDRNG = 01		20%	25%	30%	
		$I_{MONP} / I_{PD}$ with control bit PDRNG = 00		40%	50%	60%	
	Monitor diode DMI accuracy	With external calibration at 200 μA		-10%		10%	
	Bias current monitor ratio	$I_{MONB} / I_{BIAS}$ (nominal 1/100 = 1%)		0.9%	1.0%	1.1%	
	Bias current DMI accuracy	Bias current ≥ 30 mA		±10%			
	Power supply monitor accuracy	With external mid scale calibration		-2%		2%	
$V_{CC-RST}$	$V_{CC}$ reset threshold voltage	$V_{CC}$ voltage level which triggers power-on reset		2.5		2.8	V
$V_{CC-RSTHYS}$	$V_{CC}$ reset threshold voltage hysteresis			100			mV
$V_{MONB-FLT}$	Fault voltage at MONB	Fault occurs if voltage at MONB exceeds value		1.1	1.16	1.24	V

(1) The bias current can be set below the specified minimum according to the corresponding register setting, however in closed loop operation settings below the specified value may trigger a fault.

(2) Assured by simulation over process, supply and temperature variation.

## AC ELECTRICAL CHARACTERISTICS

Over recommended operating conditions, with 50Ω output load, open loop operation,  $V_{OUT} = 2.0V_{pp}$ ,  $I_{BIAS} = 80\text{ mA}$ , and  $R_{RZTC} = 28.7k\Omega$  unless otherwise noted. Typical operating condition is at  $V_{CC} = 3.3V$  and  $T_A = 25^\circ C$

PARAMETER		CONDITION	MIN	TYP	MAX	UNIT
SDD11	Differential input return gain	0.01 GHz $f < 5$ GHz		-15		dB
		5 GHz $< f < 11.1$ GHz		-8		
SCD11	Differential to common mode conversion gain	0.01 GHz $< f < 11.1$ GHz		-20		dB
$t_{R-OUT}$	Output rise time	20%–80%, $t_{R-IN} < 40$ ps, 50Ω load, single-ended, crosspoint = 50%		28	40	ps
$t_{F-OUT}$	Output fall time	20%–80%, $t_{F-IN} < 40$ ps, 50Ω load, single-ended, crosspoint = 50%		28	40	ps
$V_{O-MIN}$	Minimum output amplitude	50Ω load, single-ended			200	mVpp
$V_{O-MAX}$	Maximum output amplitude	50Ω load, single-ended	2.0			Vpp
	Output Amplitude Stability	50Ω load, single-ended			250	mV
$V_{MOD-STEP}$	Modulation voltage step size	50Ω load, 10 Bit Register		2.5		mV
DJ	Deterministic output jitter	EQENA = 1 with maximum equalization, K28.5 pattern at 11.3 Gbps, 160mVpp, 600mVpp, 1000mVpp differential input voltage, single-ended output		5	15	PS <sub>p-p</sub>
		EQENA = 1, K28.5 pattern at 11.3 Gbps, maximum equalization with 6" transmission line at the input, 160mVpp, 600mVpp, 1000mVpp input to transmission line, single-ended output		7		
RJ	Random output jitter			0.2	0.6	PS <sub>RMS</sub>
$T_{APC}$	APC time constant	$C_{APC} 0.01\ \mu F$ , $I_{PD} = 100\ \mu A$ , PD coupling ratio CR = 40 <sup>(1)</sup>		120		μs
	High cross point control range	50Ω load, single-ended		75%		
	Low cross point control range	50Ω load, single-ended		30%		
	Cross point stability	50Ω load, single-ended, $V_{IN} \geq 400mV_{pp}$		±5%		
$T_{OFF}$	Transmitter disable time	Rising edge of DIS to $I_{BIAS} \leq 0.1 \times I_{BIAS-NOMINAL}$ <sup>(1)</sup>		0.05	5	μs
$T_{ON}$	Disable negate time	Falling edge of DIS to $I_{BIAS} \geq 0.9 \times I_{BIAS-NOMINAL}$ <sup>(1)</sup>			1	ms
$T_{INIT1}$	Power-on to initialize	Power-on to registers ready to be loaded		1	10	ms
$T_{INIT2}$	Initialize to transmit	Register load STOP command to part ready to transmit valid data <sup>(1)</sup>			2	ms
$T_{RESET}$	DIS pulse width	Time DIS must held high to reset part <sup>(1)</sup>	100			ns
$T_{FAULT}$	Fault assert time	Time from fault condition to FLT high <sup>(1)</sup>			50	μs

(1) Assured by simulation over process, supply and temperature variation.

## DETAILED DESCRIPTION

### EQUALIZER

The data signal is applied to an input equalizer by means of the input signal pins DIN+/DIN–, which provide on-chip differential 100Ω line-termination. The equalizer is enabled by setting EQENA = 1 (bit 1 of register 0). Equalization of up to 150mm (6”) of microstrip or stripline transmission line on FR4 printed circuit boards can be achieved. The amount of equalization is digitally controlled by the two-wire interface and control logic block and is dependant on the register settings EQADJ[0..7] (register 6). The equalizer can be turned off and bypassed by setting EQENA = 0 and the supply current is reduced. For details about the equalizer settings, see [Table 19](#).

### LIMITER

By limiting the output signal of the equalizer to a fixed value, the limiter removes any overshoot after the input equalization and provides the input signal for the output driver. Adjustments to the limiter bias current and emitter follower current can be made to trade off the rise and fall times and supply current. The limiter bias current is adjusted through LIMCSGN (bit 7 of register 9) and LIMC[0..2] (bits 4, 5 and 6 of register 9). The emitter follower current is adjusted through EFCSGN (bit 3 of register 9) and EFC[0..2] (bits 0, 1 and 2 of register 9).

### HIGH-SPEED OUTPUT DRIVER

The modulation current is sunk from the common emitter node of the limiting output driver differential pair by means of a modulation current generator, which is digitally controlled by the 2-wire serial interface.

The collector nodes of the output stages are connected to the output pins OUT+ and OUT–. The collectors have internal 60Ω back termination resistors to VCCO. The outputs are optimized to drive a 50Ω single-ended load and to obtain the maximum single-ended output voltage of 2.0Vpp, AC coupling and inductive pull-ups to VCC are required.

The polarity of the output pins can be inverted by setting the output polarity switch bit, POL (bit 2 of register 0) to 1.

### MODULATION CURRENT GENERATOR

The modulation current generator provides the current for the current modulator described above. The circuit is digitally controlled by the 2-wire interface block.

A 10-bit wide control bus, MODC[0..9] (registers 2 and 3), is used to set the desired modulation current, and therefore, the output voltage. The modulation current can be increased by setting HCENA = 1 (bit 4 of register 1) and enabling the high modulation current mode, however, the single-ended output voltage should be kept below 2Vpp for the best performance.

The modulation current can be disabled by setting the DIS input pin to a high level or setting ENA = 0 (bit 7 of register 0). The modulation current is also disabled in a fault condition if the internal fault detection enable register flag FLTEN is set to 1 (bit 3 of register 0).

### DC OFFSET CANCELLATION AND CROSS POINT CONTROL

The ONET1141L has DC offset cancellation to compensate for internal offset voltages. The offset cancellation can be disabled by setting OCDIS = 1 (bit 3 of register 1). To adjust the eye crossing point, set CPENA = 1 (bit 2 of register 8). The crossing point can be moved toward the one level by setting CPSGN = 1 (bit 7 of register 7) and it can be moved toward the zero level by setting CPSGN = 0. The percentage of shift depends upon the register settings CPADJ[0..6] (register 7), and the cross point adjustment range bits CPRNG[0..1] (register 8). Setting CPRNG1 = 0 and CPRNG0 = 0 results in minimum adjustment capability and setting CPRNG1 = 1 and CPRNG0 = 1 results in maximum adjustment capability.

## BIAS CURRENT GENERATION AND APC LOOP

The bias current generation and APC loop are controlled by means of the 2-wire interface. In open loop operation, selected by setting OLENA = 1 (bit 4 of register 0) the bias current is set directly by the 10-bit wide control word BIASC[0..9] (registers 4 and 5). In automatic power control mode, selected by setting OLENA = 0, the bias current depends on the register settings BIASC[0..9] and the coupling ratio (CR) between the laser bias current and the photodiode current.  $CR = I_{BIAS}/I_{PD}$ . If the photodiode anode is connected to the PD pin (PD pin is sinking current), set PDPOL = 1 (bit 0 of register 0) and if the photodiode cathode is connected to the PD pin (PD pin is sourcing current), set PDPOL = 0.

Three photodiode current ranges can be selected by means of the PDRNG[0..1] bits (register 0). The photodiode range should be chosen to keep the laser bias control DAC, BIASC[0..9], close to the center of its range. This keeps the laser bias current set point resolution high. For details regarding the bias current setting in open-loop as well as in closed-loop mode, see [Table 19](#).

The ONET1141L has the ability to source or sink the bias current. The default condition is for the BIAS pin to source the current (BIASPOL = 0). To act as a sink, set BIASPOL = 1 (bit 2 of register 1).

The bias current is monitored using a current mirror with a gain equal to 1/100. By connecting a resistor between MONB and GND, the bias current can be monitored as a voltage across the resistor. A low temperature coefficient precision resistor should be used. The bias current can also be monitored as a 10 bit unsigned digital word through the 2-wire interface by setting DMONB = 1 (bit 0 of register 10) and removing the resistor to ground.

## ANALOG REFERENCE AND TEMPERATURE SENSOR

The ONET1141L modulator driver is supplied by a single  $3.3V \pm 10\%$  supply voltage connected to the VCC and VCCO pins. This voltage is referred to ground (GND) and can be monitored as a 10 bit unsigned digital word through the 2-wire interface.

On-chip bandgap voltage circuitry generates a reference voltage, independent of the supply voltage, from which all other internally required voltages and bias currents are derived.

An external zero temperature coefficient resistor must be connected from the RZTC pin of the device to ground. This resistor is used to generate a precise, zero-TC current which is required as a reference current for the on-chip DACs.

The ONET1141L provides an on-chip temperature sensor which can be monitored as a 10 bit unsigned digital word through the 2-wire interface.

## POWER-ON RESET

The ONET1141L has power on reset circuitry which ensures that all registers are reset to zero during startup. After the power-on to initialize time ( $t_{INIT1}$ ), the internal registers are ready to be loaded. The part is ready to transmit data after the initialize to transmit time ( $t_{INIT2}$ ), assuming that the chip enable bit ENA is set to 1 and the disable pin DIS is low. The DIS pin has an internal  $10k\Omega$  pull up resistor so the pin must be pulled low to enable the outputs. The ONET1141L can be disabled using either the ENA control register bit or the disable pin DIS. In both cases the internal registers are not reset. After the disable pin DIS is set low and/or the enable bit ENA is set back to 1, the part returns to its prior output settings.

To reduce the disable time, only the output stage can be disabled by setting DISMODE = 1 (bit 1 of register 1).

## ANALOG TO DIGITAL CONVERTER

The ONET1141L has an internal 10 bit analog to digital converter (ADC) that converts the analog monitors for temperature, power supply voltage, bias current and photodiode current into a 10 bit unsigned digital word. The first 8 most significant bits (MSBs) are available in register 14 and the 2 least significant bits (LSBs) are available in register 15. Depending on the accuracy required, 8 bits or 10 bits can be read. However, due to the architecture of the 2-wire interface, in order to read the 2 registers, 2 separate read commands have to be sent.

The ADC is enabled by default so to monitor a particular parameter, select the parameter with ADCSEL[0..1] (bits 0 and 1 of register 13). [Table 1](#) shows the ADCSEL bits and the parameter that is monitored.

**Table 1. ADC Selection Bits and the Monitored Parameter**

ADCSEL1	ADCSEL0	Monitored Parameter
0	0	Temperature
0	1	Supply voltage
1	0	Photodiode current
1	1	Bias current

To digitally monitor the photodiode current, ensure that DMONP = 1 (bit 1 of register 10) and that a resistor is not connected to the MONP pin. To digitally monitor the bias current, ensure that DMONB = 1 (bit 0 of register 10) and that a resistor is not connected to the MONB pin. If it is not desired to use the ADC to monitor the various parameters then the ADC can be disabled by setting ADCDIS = 1 (bit 7 of register 13) and OSCDIS = 1 (bit 6 of register 13).

The digital word read from the ADC can be converted to its analog equivalent through the following formulas:

#### Temperature Without a Mid-Point Calibration

$$\text{Temperature } (^{\circ}\text{C}) = (\text{ADCx} - 264) / 6 \quad (1)$$

#### Temperature With a Mid-Point Calibration

$$\text{Temperature } (^{\circ}\text{C}) = (\text{T\_cal} (^{\circ}\text{C}) + 273) \times (\text{ADCx} + 1362) / (\text{ADC\_cal} + 1362) - 273 \quad (2)$$

#### Power Supply Voltage

$$\text{Power supply voltage (V)} = 2.25 \times (\text{ADCx} + 1380) / 1409 \quad (3)$$

#### Photodiode Current Monitor

$$\text{IPD } (\mu\text{A}) = 1.3 \times \text{ADCx} \quad (4)$$

#### Bias Current Monitor

$$\text{Source mode: IBIAS (mA)} = 0.177 \times \text{ADCx}$$

$$\text{Sink mode: IBIAS (mA)} = 0.19 \times \text{ADCx} \quad (5)$$

Where:

ADCx = the decimal value read from the ADC

T\_cal = the calibration temperature

ADC\_cal = the decimal value read from the ADC at the calibration temperature

## 2-WIRE INTERFACE AND CONTROL LOGIC

The ONET1141L uses a 2-wire serial interface for digital control. The two circuit inputs, SDA and SCK, are driven, respectively, by the serial data and serial clock from a microprocessor, for example. The SDA and SCK pins have internal 10kΩ pull ups to VCC. If a common interface is used to control multiple parts, the internal pull ups can be set to 40kΩ by setting TWITERM to 1 (bit 7 of register 1). This will also set the internal pullup on the DIS pin to 40 kΩ.

The 2-wire interface allows write access to the internal memory map to modify control registers and read access to read out the control signals. The ONET1141L is a slave device only which means that it cannot initiate a transmission itself; it always relies on the availability of the SCK signal for the duration of the transmission. The master device provides the clock signal as well as the START and STOP commands. The protocol for a data write transmission is as follows:

1. START command
2. 7 bit slave address (0001000) followed by an eighth bit (value = 0) which is the data write bit (W).
3. 8 bit register address
4. 8 bit register data word
5. STOP command

The first 2 bits of the slave address can be changed to 1 by grounding the ADR0 and ADR1 pins.

# ONET1141L

SLLSEB7 –MAY 2012

www.ti.com

Regarding timing, the ONET1141L is I<sup>2</sup>C compatible. The typical timing is shown in Figure 2 and complete data write and read transfers are shown in Figure 3. Parameters for Figure 2 are defined in Table 2.

**Bus Idle:** Both SDA and SCK lines remain HIGH

**Start Data Transfer:** A change in the state of the SDA line, from HIGH to LOW, while the SCK line is HIGH, defines a START condition (S). Each data transfer is initiated with a START condition.

**Stop Data Transfer:** A change in the state of the SDA line from LOW to HIGH while the SCK line is HIGH defines a STOP condition (P). Each data transfer is terminated with a STOP condition; however, if the master still wishes to communicate on the bus, it can generate a repeated START condition and address another slave without first generating a STOP condition.

**Data Transfer:** Only one data byte can be transferred between a START and a STOP condition. The receiver acknowledges the transfer of data.

**Acknowledge:** Each receiving device, when addressed, is obliged to generate an acknowledge bit. The transmitter releases the SDA line and a device that acknowledges must pull down the SDA line during the acknowledge clock pulse in such a way that the SDA line is stable LOW during the HIGH period of the acknowledge clock pulse. Setup and hold times must be taken into account. When a slave-receiver doesn't acknowledge the slave address, the data line must be left HIGH by the slave. The master can then generate a STOP condition to abort the transfer. If the slave-receiver does acknowledge the slave address but some time later in the transfer cannot receive any more data bytes, the master must abort the transfer. This is indicated by the slave generating the not acknowledge on the first byte to follow. The slave leaves the data line HIGH and the master generates the STOP condition.

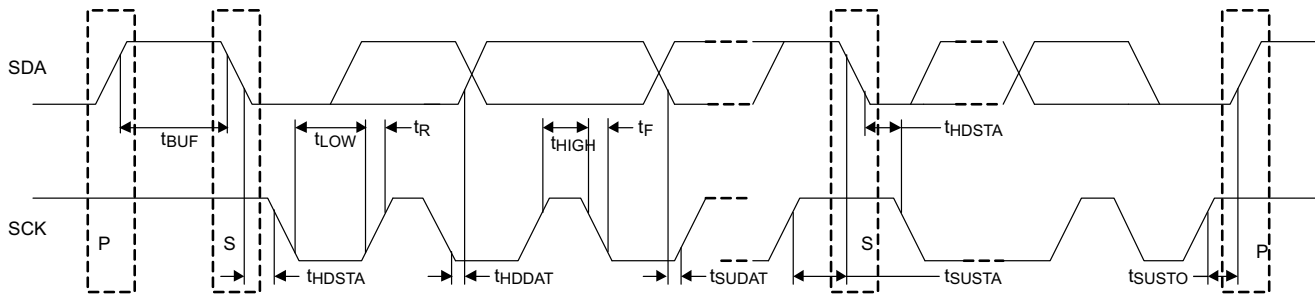
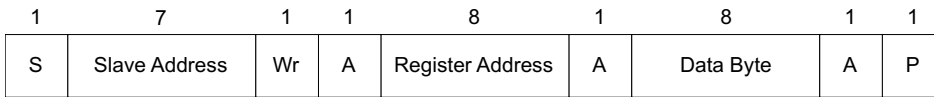

Figure 2. I<sup>2</sup>C Timing Diagram

Table 2. Timing Diagram Definitions

SYMBOL	PARAMETER	MIN	MAX	UNIT
f <sub>SCK</sub>	SCK clock frequency		400	kHz
t <sub>BUF</sub>	Bus free time between STOP and START conditions	1.3		μs
t <sub>HDSTA</sub>	Hold time after repeated START condition. After this period, the first clock pulse is generated	0.6		μs
t <sub>LOW</sub>	Low period of the SCK clock	1.3		μs
t <sub>HIGH</sub>	High period of the SCK clock	0.6		μs
t <sub>SUSTA</sub>	Setup time for a repeated START condition	0.6		μs
t <sub>HDDAT</sub>	Data HOLD time	0		μs
t <sub>SUDAT</sub>	Data setup time	100		ns
t <sub>R</sub>	Rise time of both SDA and SCK signals		300	ns
t <sub>F</sub>	Fall time of both SDA and SCK signals		300	ns
t <sub>SUSTO</sub>	Setup time for STOP condition	0.6		μs

Write Sequence



Read Sequence

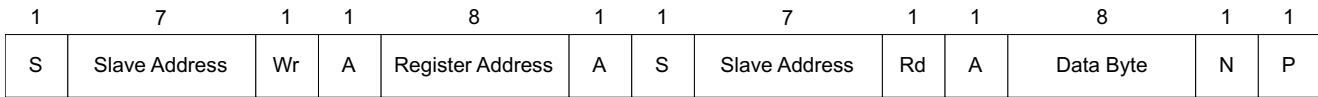

Legend

- S** Start Condition
- Wr** Write Bit (bit value = 0)
- Rd** Read Bit (bit value = 1)
- A** Acknowledge
- N** Not Acknowledge
- P** Stop Condition

**Figure 3. Programming Sequence**

**REGISTER MAPPING**

The register mapping for register addresses 0 (0x00) through 15 (0x0F) are shown in [Table 3](#) through [Table 18](#). [Table 19](#) describes the circuit functionality based on the register settings.

**Table 3. Register 0 (0x00) Mapping – Control Settings**

register address 0 (0x00)							
bit 7	bit 6	bit 5	bit 4	bit 3	bit 2	bit 1	bit 0
ENA	PDRNG1	PDRNG0	OLENA	FLTEN	POL	EQENA	PDPOL

**Table 4. Register 1 (0x01) Mapping – Control Settings**

register address 1 (0x01)							
bit 7	bit 6	bit 5	bit 4	bit 3	bit 2	bit 1	bit 0
TWITERM	HIEFCENA	HIEQGENA	HCENA	OCDIS	BIASPOL	DISMODE	LOGENA

**Table 5. Register 2 (0x02) Mapping – Modulation Current**

register address 2 (0x02)							
bit 7	bit 6	bit 5	bit 4	bit 3	bit 2	bit 1	bit 0
–	–	–	–	–	–	MODC1	MODC0

**Table 6. Register 3 (0x03) Mapping – Modulation Current**

register address 3 (0x03)							
bit 7	bit 6	bit 5	bit 4	bit 3	bit 2	bit 1	bit 0
MODC9	MODC8	MODC7	MODC6	MODC5	MODC4	MODC3	MODC2

**Table 7. Register 4 (0x04) Mapping – Bias Current**

register address 4 (0x04)							
bit 7	bit 6	bit 5	bit 4	bit 3	bit 2	bit 1	bit 0
–	–	–	–	–	–	BIASC1	BIASC0

**Table 8. Register 5 (0x05) Mapping – Bias Current**

register address 5 (0x05)							
bit 7	bit 6	bit 5	bit 4	bit 3	bit 2	bit 1	bit 0
BIASC9	BIASC8	BIASC7	BIASC6	BIASC5	BIASC4	BIASC3	BIASC2

**Table 9. Register 6 (0x06) Mapping – Equalizer Adjust**

register address 6 (0x06)							
bit 7	bit 6	bit 5	bit 4	bit 3	bit 2	bit 1	bit 0
EQADJ7	EQADJ6	EQADJ5	EQADJ4	EQADJ3	EQADJ2	EQADJ1	EQADJ0

**Table 10. Register 7 (0x07) Mapping – Cross Point Adjust**

register address 7 (0x07)							
bit 7	bit 6	bit 5	bit 4	bit 3	bit 2	bit 1	bit 0
CPSGN	CPADJ6	CPADJ5	CPADJ4	CPADJ3	CPADJ2	CPADJ1	CPADJ0

**Table 11. Register 8 (0x08) Mapping – Cross Point Control Settings**

register address 8 (0x08)							
bit 7	bit 6	bit 5	bit 4	bit 3	bit 2	bit 1	bit 0
IDRV	–	–	CPREF	–	CPENA	CPRNG1	CPRNG0

**Table 12. Register 9 (0x09) Mapping – Limiter Bias Current Adjust**

register address 9 (0x09)							
bit 7	bit 6	bit 5	bit 4	bit 3	bit 2	bit 1	bit 0
LIMCSGN	LMC2	LIMC1	LIMC0	EFCSGN	EFC2	EFC1	EFC0

**Table 13. Register 10 (0x0A) Mapping – Monitor Settings**

register address 10 (0x0A)							
bit 7	bit 6	bit 5	bit 4	bit 3	bit 2	bit 1	bit 0
–	–	–	–	–	MONPFLT	DMONP	DMONB

**Table 14. Register 11 (0x0B) Mapping – Bias Monitor Fault Settings**

register address 11 (0x0B)							
bit 7	bit 6	bit 5	bit 4	bit 3	bit 2	bit 1	bit 0
BMF7	BMF6	BMF5	BMF4	BMF3	BMF2	BMF1	BMF0

**Table 15. Register 12 (0x0C) Mapping – Power Monitor Fault Settings**

register address 12 (0x0C)							
bit 7	bit 6	bit 5	bit 4	bit 3	bit 2	bit 1	bit 0
PMF7	PMF6	PMF5	PMF4	PMF3	PMF2	PMF1	PMF0

**Table 16. Register 13 (0x0D) Mapping – ADC Settings**

register address 13 (0x0D)							
bit 7	bit 6	bit 5	bit 4	bit 3	bit 2	bit 1	bit 0
ADCDIS	OSCDIS	–	–	–	–	ADCSEL1	ADCSEL0

**Table 17. Register 14 (0x0E) Mapping – ADC Output (Read Only)**

register address 14 (0x0E)							
bit 7	bit 6	bit 5	bit 4	bit 3	bit 2	bit 1	bit 0
ADC9	ADC8	ADC7	ADC6	ADC5	ADC4	ADC3	ADC2

**Table 18. Register 15 (0x0F) Mapping – ADC Output (Read Only)**

register address 15 (0x0F)							
bit 7	bit 6	bit 5	bit 4	bit 3	bit 2	bit 1	bit 0
–	–	–	–	–	–	ADC1	ADC0

**Table 19. Register Functionality**

REGISTER	BIT	SYMBOL	FUNCTION
0	7	ENA	<b>Enable chip bit</b> 1 = Chip enabled. Can be toggled low to reset a fault condition. 0 = Chip disabled
	6 5	PDRNG1 PDRNG0	<b>Photodiode current range bits</b> 1X: up to 3080µA / 3µA resolution 01: up to 1540µA / 1.5µA resolution 00: up to 770µA / 0.75µA resolution
	4	OLENA	<b>Open loop enable bit</b> 1 = Open loop bias current control, 0 = Closed loop bias current control
	3	FLTEN	<b>Fault detection enable bit</b> 1 = Fault detection on 0 = Fault detection off
	2	POL	<b>Output polarity switch bit</b> 1: pin 22 = OUT- and pin 21= OUT+ 0: pin 22 = OUT+ and pin 21 = OUT-
	1	EQENA	<b>Equalizer enable bit</b> 1 = Equalizer is enabled 0 = Equalizer is disabled and bypassed
	0	PDPOL	<b>Photodiode polarity bit</b> 1 = Photodiode cathode connected to V <sub>CC</sub> 0 = Photodiode anode connected to GND

**Table 19. Register Functionality (continued)**

REGISTER	BIT	SYMBOL	FUNCTION
1	7	TWITERM	<b>Two wire interface input termination select bit</b> 1 = 40kΩ selected 0 = 10kΩ selected
	6	HIEFCENA	<b>High emitter follower drive current enable bit</b> 1 = High current enabled 0 = High current disabled
	5	HIEQGENA	<b>High gain enable for EQ stage (with EQENA = 1)</b> 1 = High gain enabled 0 = High gain disabled
	4	HCENA	<b>High modulation current enable bit</b> 1 = High modulation current enabled 0 = High modulation current disabled
	3	OCDIS	<b>Offset cancellation disable bit</b> 1 = DC offset cancellation is disabled 0 = DC offset cancellation is enabled
	2	BIASPOL	<b>Bias current polarity bit</b> 1 = Bias pin sinks current 0 = Bias pin sources current
	1	DISMODE	<b>Disable mode setting bit</b> 1 = Only the output stage is disabled (fast disable mode) 0 = Major parts of the signal path are disabled
	0	LOGENA	<b>Low gain enable for input amplifier (with EQENA = 0)</b> 1 = Low gain enabled 0 = Default gain
3	7	MODC9	<b>Modulation current setting: sets the output voltage</b>  Output Voltage: 2.3Vpp / 2.5mV steps
	6	MODC8	
	5	MODC7	
	4	MODC6	
	3	MODC5	
	2	MODC4	
	1	MODC3	
	0	MODC2	
2	1	MODC1	
	0	MODC0	
5	7	BIASC9	<b>Bias current settings</b> <b>Closed loop (APC):</b> Coupling ratio $CR = I_{BIAS} / I_{PD}$ , $BIASC = 0..1023$ , $I_{BIAS} \leq 150mA$ :  PDRNG = 00 (see above); $I_{BIAS} = 0.75\mu A \times CR \times BIASC$ PDRNG = 01 (see above); $I_{BIAS} = 1.5\mu A \times CR \times BIASC$ PDRNG = 1X (see above); $I_{BIAS} = 3\mu A \times CR \times BIASC$  <b>Open loop:</b>
	6	BIASC8	
	5	BIASC7	
	4	BIASC6	
	3	BIASC5	
	2	BIASC4	
	1	BIASC3	
	0	BIASC2	
4	1	BIASC1	$I_{BIAS} \sim 150\mu A \times BIASC$ in source mode $I_{BIAS} \sim 100\mu A \times BIASC$ in sink mode
	0	BIASC0	

**Table 19. Register Functionality (continued)**

REGISTER	BIT	SYMBOL	FUNCTION
6	7	EQADJ7	<b>Equalizer adjustment setting</b>
	6	EQADJ6	
	5	EQADJ5	
	4	EQADJ4	
	3	EQADJ3	
	2	EQADJ2	
	1	EQADJ1	
	0	EQADJ0	
7	7	CPSGN	Eye cross-point adjustment setting
	6	CPADJ6	CPSGN = 1 (positive shift)
	5	CPADJ5	Maximum shift for 1111111
	4	CPADJ4	Minimum shift for 0000000
	3	CPADJ3	CPSGN = 0 (negative shift)
	2	CPADJ2	Maximum shift for 1111111
	1	CPADJ1	Minimum shift for 0000000
	0	CPADJ0	
8	7	IDRV	<b>Output Driver Tail Current Bit</b> 1 = Output driver tail current is increased 0 = Output driver tail current is set to default
	6	-	
	5	-	
	4	CPREF	<b>Cross point temperature coefficient selection bit</b> 1 = Reverses the behavior and EQENA = 1: temperature coefficient disabled and EQENA = 0: temperature coefficient enabled 0 = Default condition and EQENA = 1: temperature coefficient enabled and EQENA = 0: temperature coefficient disabled
	3	-	
	2	CPENA	<b>Cross point adjustment enable bit</b> 1 = Cross point adjustment is enabled 0 = Cross point adjustment is disabled
	1	CPRNG1	<b>Cross point adjustment range bits</b> Minimum adjustment range for 00 Maximum adjustment range for 11
	0	CPRNG0	
9	7	<b>LIMCSGN</b>	Limiter bias current sign bit 1 = Decrease limiter bias current 0 = Increase limiter bias current
	6	LIMC2	<b>Limiter bias current selection bits</b> 000 = No change 111 = Maximum current change
	5	LIMC1	
	4	LIMC0	
	3	EFCSGN	<b>Emitter follower sign bit</b> 1 = Decrease emitter follower current 0 = Increase emitter follower current
	2	EFC2	Emitter follower current selection bits 000 = No change 111 = Maximum current change
	1	EFC1	
	0	EFC0	

**Table 19. Register Functionality (continued)**

REGISTER	BIT	SYMBOL	FUNCTION
10	7	-	
	6	-	
	5	-	
	4	-	
	3	-	
	2	MONPFLT	<b>Analog photodiode current monitor fault trigger bit</b> 1 = Fault trigger on MONP pin is enabled 0 = Fault trigger on MONP pin is disabled
	1	DMONP	<b>Digital photodiode current monitor selection bit (MONP)</b> 1 = Digital photodiode monitor is active (external resistor must not be installed) 0 = Analog photodiode monitor is active (external resistor is required)
	0	DMONB	<b>Digital bias current monitor selection bit (MONB)</b> 1 = Digital bias current monitor is active (external resistor must not be installed) 0 = Analog bias current monitor is active (external resistor is required)
11	7	BMF7	<b>Bias current monitor fault threshold</b> With DMONB = 1 Register sets the value of the bias current that will trigger a fault. The external resistor on the MONB pin must be removed to use this feature.
	6	BMF6	
	5	BMF5	
	4	BMF4	
	3	BMF3	
	2	BMF2	
	1	BMF1	
	0	BMF0	
12	7	PMF7	<b>Power monitor fault threshold</b> With DMONP = 1 Register sets the value of the photodiode current that will trigger a fault The external resistor on the MONP pin must be removed to use this feature.
	6	PMF6	
	5	PMF5	
	4	PMF4	
	3	PMF3	
	2	PMF2	
	1	PMF1	
	0	PMF0	
13	7	ADCDIS	<b>ADC disable bit</b> 1 = ADC disabled 0 = ADC enabled
	6	OSCDIS	<b>ADC oscillator bit</b> 1 = Oscillator disabled 0 = Oscillator enabled
	5		
	4		
	3		
	2		
	1	ADCSEL1	<b>ADC input selection bits</b> 00 selects the temperature sensor 01 selects the power supply monitor 10 selects MONP 11 selects MONB
	0	ADCSEL0	

**Table 19. Register Functionality (continued)**

REGISTER	BIT	SYMBOL	FUNCTION
14	7	ADC9 (MSB)	Digital representation of the ADC input source (read only)
	6	ADC8	
	5	ADC7	
	4	ADC6	
	3	ADC5	
	2	ADC4	
	1	ADC3	
	0	ADC2	
15	7	-	
	6	-	
	5	-	
	4	-	
	3	-	
	2	-	
	1	ADC1	
	0	ADC0 (LSB)	

## LASER SAFETY FEATURES AND FAULT RECOVERY PROCEDURE

The ONET1141L provides built in laser safety features. The following fault conditions are detected:

1. Voltage at MONB exceeds the voltage at RZTC (1.16V) or, alternately, if DMONB = 1 and the bias current exceeds the bias current monitor fault threshold set by BMF[0..7] (register 11). When using the digital monitor, the resistor to ground must be removed.
2. Voltage at MONP exceeds the voltage at RZTC (1.16V) and the analog photodiode current monitor fault trigger bit, MONPFLT (bit 2 of register 10), is set to 1. Alternately, a fault can be triggered if DMONP = 1 and the photodiode current exceeds the photodiode current monitor fault threshold set by PMF[0..7] (register 12). When using the digital monitor, the resistor to ground must be removed.
3. Photodiode current exceeds 150% of its set value,
4. Bias control DAC drops in value by more than 50% in one step.

If one or more fault conditions occur and the fault enable bit FLTEN is set to 1, the ONET1141L responds by:

1. Setting the bias current to zero.
2. Setting the modulation current to zero.
3. Asserting and latching the FLT pin.

Fault recovery is performed by the following procedure:

1. The disable pin DIS and/or the internal enable control bit ENA are toggled for at least the fault latch reset time.
2. The FLT pin de-asserts while the disable pin DIS is asserted or the enable bit ENA is de-asserted.
3. If the fault condition is no longer present, the part will return to normal operation with its prior output settings after the disable negate time.
4. If the fault condition is still present, FLT re-asserts once DIS is set to a low level and the part will not return to normal operation.

**TYPICAL CHARACTERISTICS**

Typical operating condition is at  $V_{CC} = 3.3V$ ,  $T_A = 25^\circ C$ ,  $I_{BIASC} = 80mA$ ,  $V_{OUT} = 2V_{PP}$ ,  $V_{IN} = 400mV_{pp}$  (unless otherwise noted).

**DETERMINISTIC JITTER  
vs  
MODULATION CURRENT**

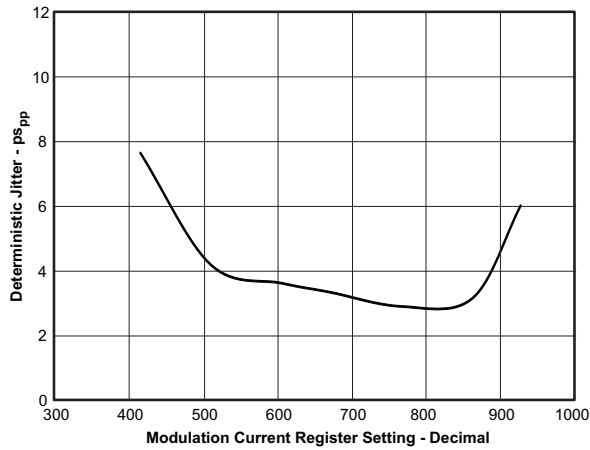

Figure 4.

**DETERMINISTIC JITTER  
vs  
TEMPERATURE**

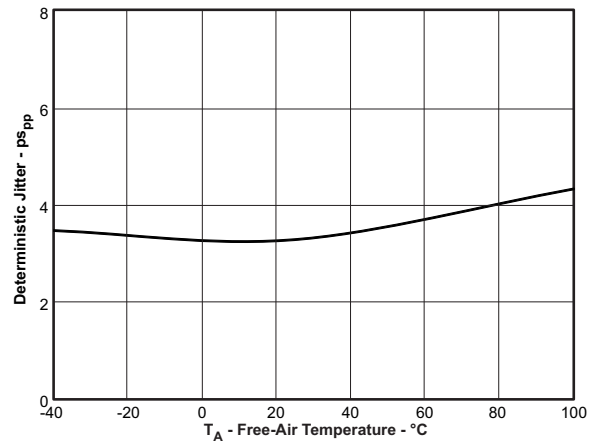

Figure 5.

**RANDOM JITTER  
vs  
MODULATION CURRENT**

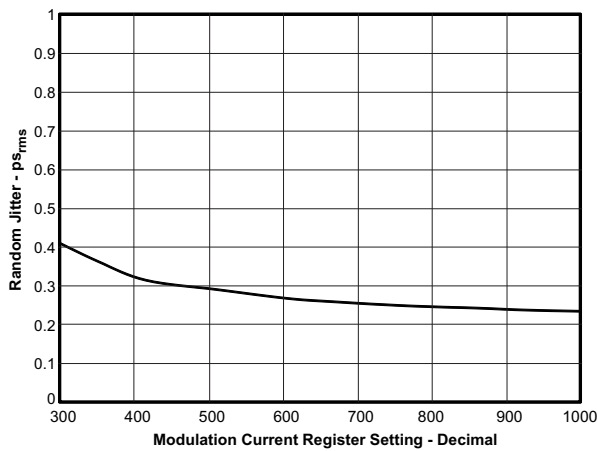

Figure 6.

**RANDOM JITTER  
vs  
TEMPERATURE**

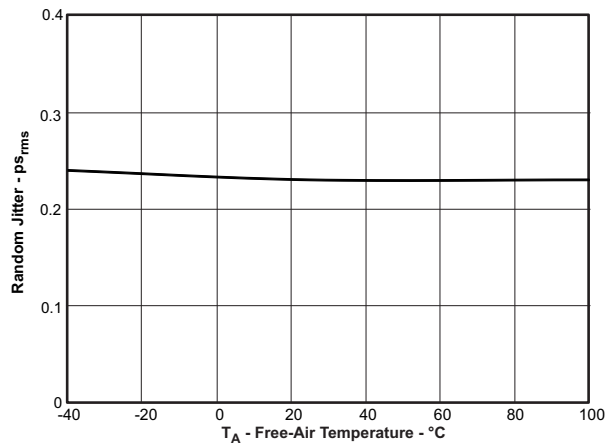

Figure 7.

**TYPICAL CHARACTERISTICS (continued)**

Typical operating condition is at  $V_{CC} = 3.3V$ ,  $T_A = 25^\circ C$ ,  $I_{BIASC} = 80mA$ ,  $V_{OUT} = 2V_{PP}$ ,  $V_{IN} = 400mV_{pp}$  (unless otherwise noted).

**RISE-TIME AND FALL-TIME  
vs  
MODULATION CURRENT**

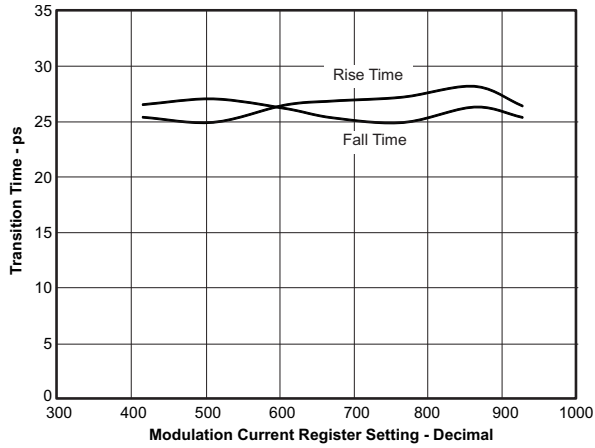

Figure 8.

**RISE-TIME AND FALL-TIME  
vs  
TEMPERATURE**

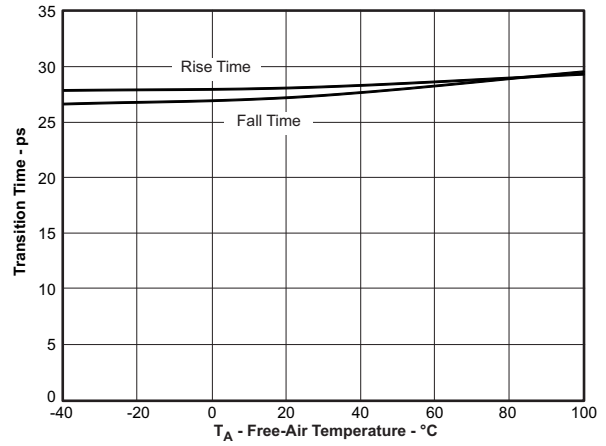

Figure 9.

**BIAS CURRENT IN OPEN LOOP MODE  
vs  
BIAS CURRENT REGISTER SETTING**

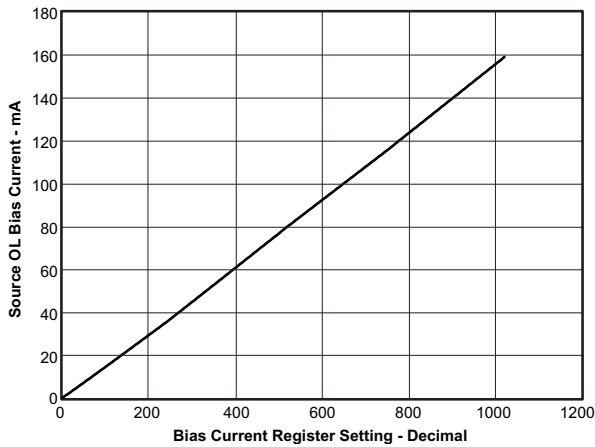

Figure 10.

**BIAS CURRENT IN OPEN LOOP MODE  
vs  
BIAS CURRENT REGISTER SETTING**

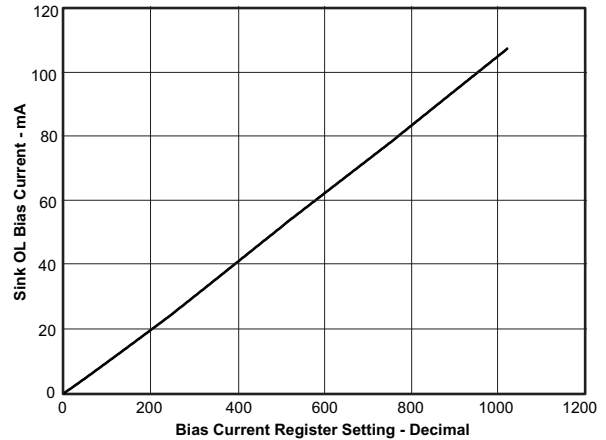

Figure 11.

**TYPICAL CHARACTERISTICS (continued)**

Typical operating condition is at  $V_{CC} = 3.3V$ ,  $T_A = 25^\circ C$ ,  $I_{BIASC} = 80mA$ ,  $V_{OUT} = 2V_{PP}$ ,  $V_{IN} = 400mV_{pp}$  (unless otherwise noted).

**BIAS MONITOR CURRENT  
vs  
BIAS CURRENT**

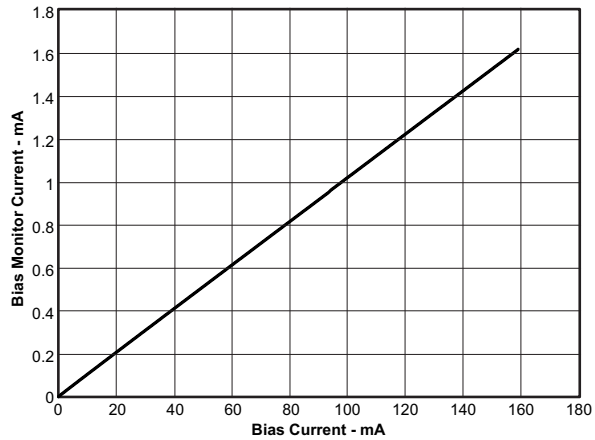

Figure 12.

**PHOTODIODE MONITOR CURRENT  
vs  
PHOTODIODE CURRENT**

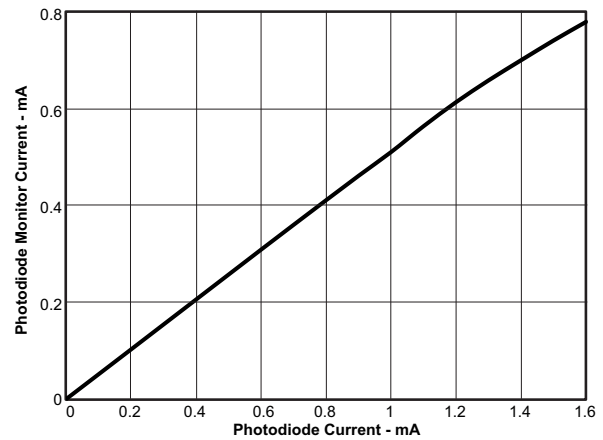

Figure 13.

**OUTPUT VOLTAGE  
vs  
MODC REGISTER SETTING**

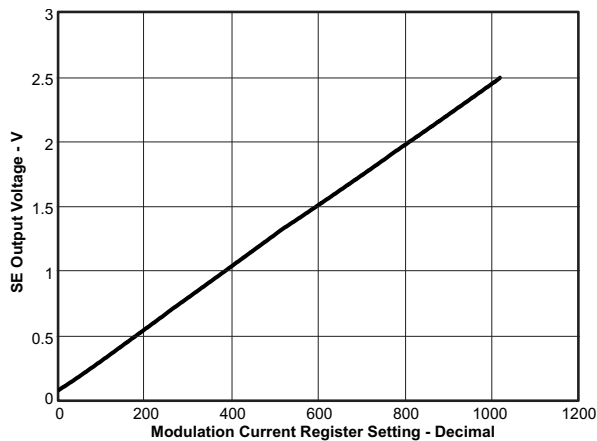

Figure 14.

**SUPPLY CURRENT  
vs  
TEMPERATURE**

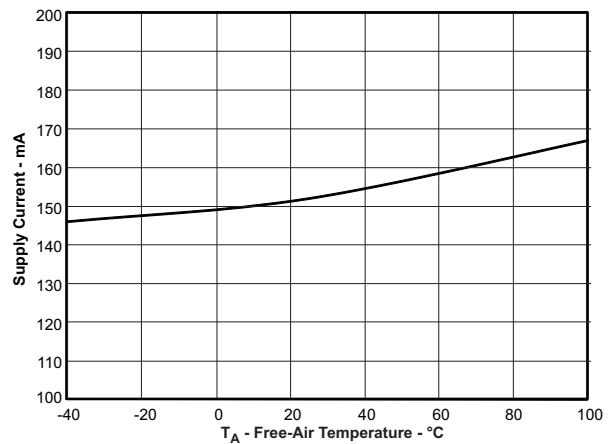

Figure 15.

**TYPICAL CHARACTERISTICS (continued)**

Typical operating condition is at  $V_{CC} = 3.3V$ ,  $T_A = 25^\circ C$ ,  $I_{BIASC} = 80mA$ ,  $V_{OUT} = 2V_{PP}$ ,  $V_{IN} = 400mV_{pp}$  (unless otherwise noted).

**EYE-DIAGRAM AT 10.31GBPS**  
 $V_{OUT}=2V_{PP}$ , EQ Set to 00

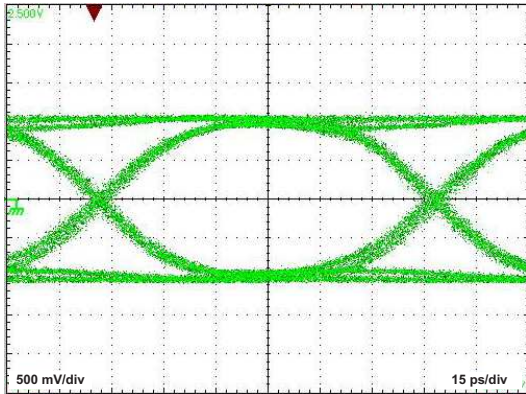

Figure 16.

**EYE-DIAGRAM AT 11.3GBPS**  
 $V_{OUT}=2V_{PP}$ , EQ Set to 00, 50% Cross Point

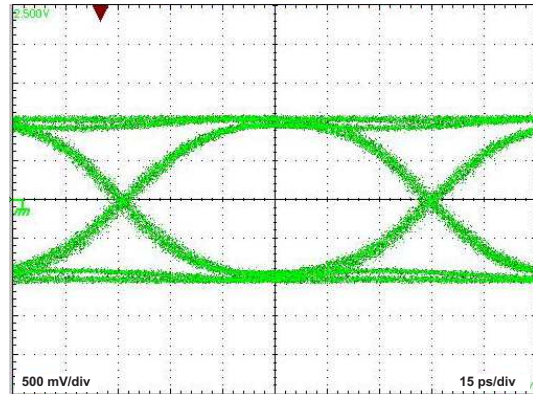

Figure 17.

**EYE-DIAGRAM AT 11.3GBPS**  
 $V_{OUT}=2V_{PP}$ , EQ Set to 00, 30% Cross Point

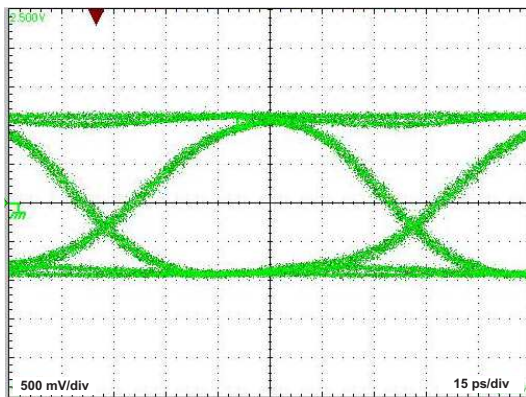

Figure 18.

**EYE-DIAGRAM AT 11.3GBPS**  
 $V_{OUT}=2V_{PP}$ , EQ Set to 00, 70% Cross Point

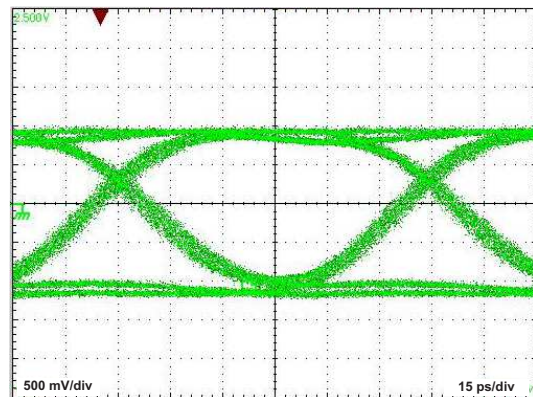

Figure 19.

**EYE-DIAGRAM AT 11.3GBPS**  
 $V_{OUT}=2V_{PP}$ , EQ Set to 00,  
 6" OF FR4 AT INPUTS

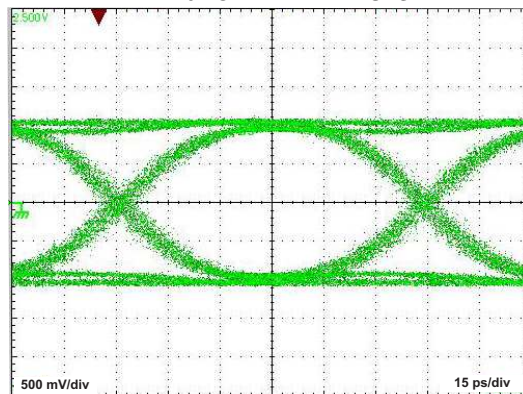
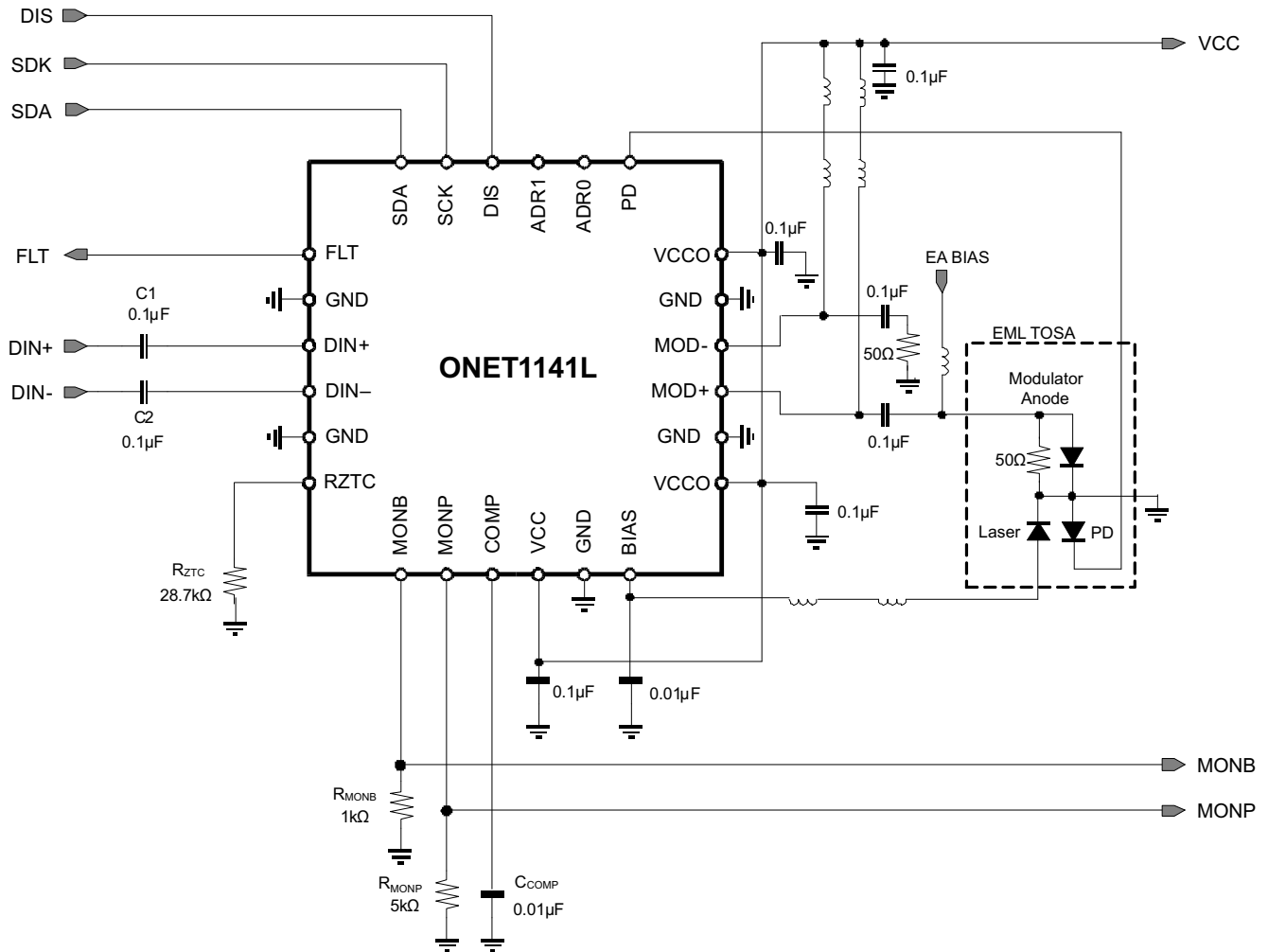

Figure 20.

## APPLICATION INFORMATION

Figure 21 and Figure 22 show typical application circuits using the ONET1141L. The modulator must be AC coupled to the driver for proper operation. The laser driver is controlled via the 2-wire interface SDA/SCK by a microcontroller. In a typical application, the FLT, MONB and MONP outputs are also connected to the microcontroller for transceiver management purposes.

The component values in Figure 21 and Figure 22 are typical examples and may be varied according to the intended application.



**Figure 21. AC Coupled Drive with PD Monitor Cathode Available**

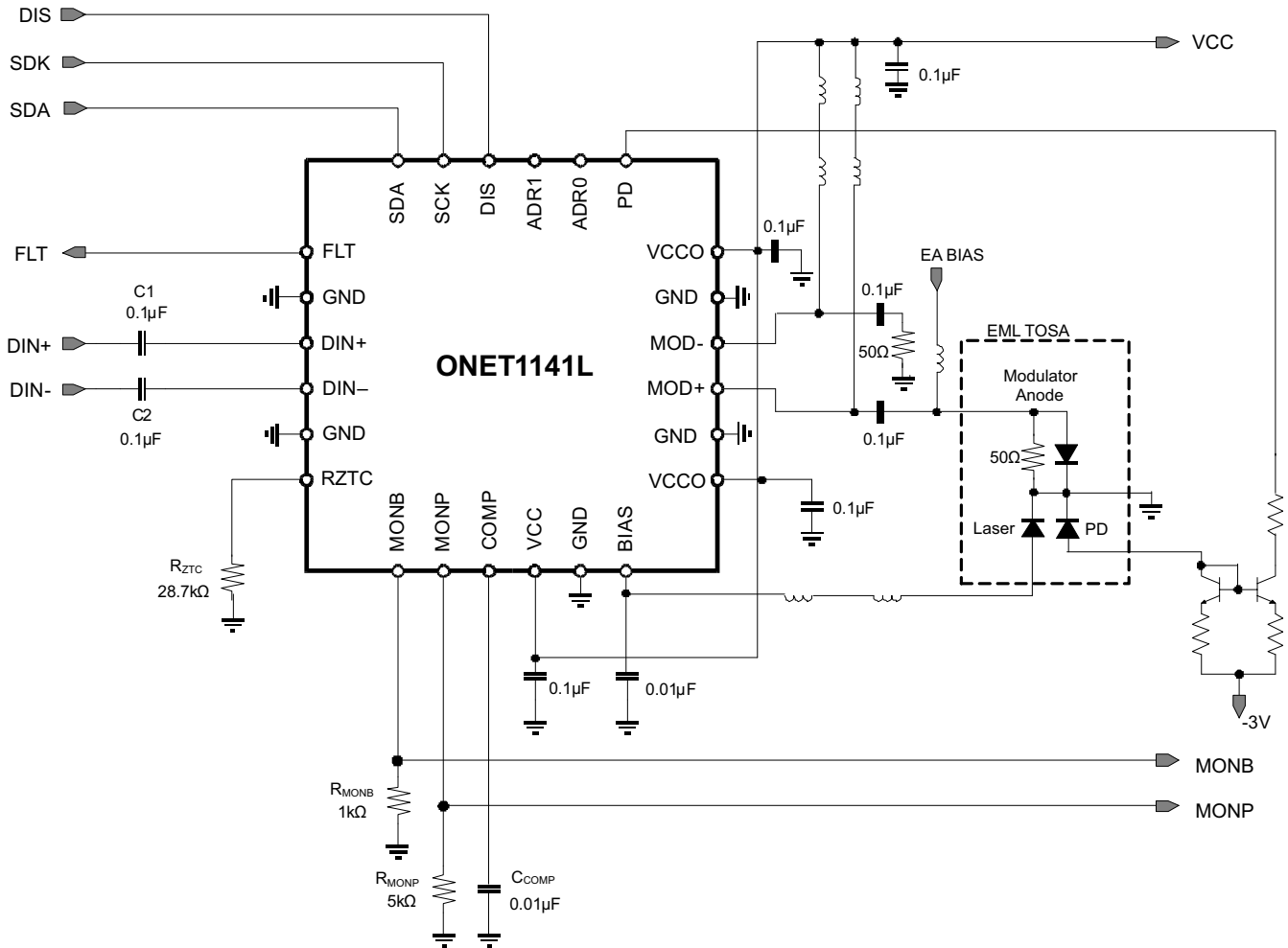

Figure 22. AC Coupled Drive with PD Monitor Anode Available

### Layout Guidelines

For optimum performance, use 50 $\Omega$  transmission lines (100 $\Omega$  differential) for connecting the signal source to the DIN+ and DIN- pins and 50 $\Omega$  transmission lines (100 $\Omega$  differential) for connecting the modulation current outputs, MOD+ and MOD-, to the laser. The length of the transmission lines should be kept as short as possible to reduce loss and pattern-dependent jitter.

**PACKAGING INFORMATION**

Orderable Device	Status (1)	Package Type	Package Drawing	Pins	Package Qty	Eco Plan (2)	Lead/Ball Finish (6)	MSL Peak Temp (3)	Op Temp (°C)	Device Marking (4/5)	Samples
ONET1141LRGER	ACTIVE	VQFN	RGE	24	3000	Green (RoHS & no Sb/Br)	CU NIPDAU	Level-2-260C-1 YEAR	-40 to 100	ONET 1141L	<a href="#">Samples</a>
ONET1141LRGET	ACTIVE	VQFN	RGE	24	250	Green (RoHS & no Sb/Br)	CU NIPDAU	Level-2-260C-1 YEAR	-40 to 100	ONET 1141L	<a href="#">Samples</a>

(1) The marketing status values are defined as follows:

**ACTIVE:** Product device recommended for new designs.

**LIFEBUY:** TI has announced that the device will be discontinued, and a lifetime-buy period is in effect.

**NRND:** Not recommended for new designs. Device is in production to support existing customers, but TI does not recommend using this part in a new design.

**PREVIEW:** Device has been announced but is not in production. Samples may or may not be available.

**OBSOLETE:** TI has discontinued the production of the device.

(2) Eco Plan - The planned eco-friendly classification: Pb-Free (RoHS), Pb-Free (RoHS Exempt), or Green (RoHS & no Sb/Br) - please check <http://www.ti.com/productcontent> for the latest availability information and additional product content details.

**TBD:** The Pb-Free/Green conversion plan has not been defined.

**Pb-Free (RoHS):** TI's terms "Lead-Free" or "Pb-Free" mean semiconductor products that are compatible with the current RoHS requirements for all 6 substances, including the requirement that lead not exceed 0.1% by weight in homogeneous materials. Where designed to be soldered at high temperatures, TI Pb-Free products are suitable for use in specified lead-free processes.

**Pb-Free (RoHS Exempt):** This component has a RoHS exemption for either 1) lead-based flip-chip solder bumps used between the die and package, or 2) lead-based die adhesive used between the die and leadframe. The component is otherwise considered Pb-Free (RoHS compatible) as defined above.

**Green (RoHS & no Sb/Br):** TI defines "Green" to mean Pb-Free (RoHS compatible), and free of Bromine (Br) and Antimony (Sb) based flame retardants (Br or Sb do not exceed 0.1% by weight in homogeneous material)

(3) MSL, Peak Temp. - The Moisture Sensitivity Level rating according to the JEDEC industry standard classifications, and peak solder temperature.

(4) There may be additional marking, which relates to the logo, the lot trace code information, or the environmental category on the device.

(5) Multiple Device Markings will be inside parentheses. Only one Device Marking contained in parentheses and separated by a "~" will appear on a device. If a line is indented then it is a continuation of the previous line and the two combined represent the entire Device Marking for that device.

(6) Lead/Ball Finish - Orderable Devices may have multiple material finish options. Finish options are separated by a vertical ruled line. Lead/Ball Finish values may wrap to two lines if the finish value exceeds the maximum column width.

**Important Information and Disclaimer:** The information provided on this page represents TI's knowledge and belief as of the date that it is provided. TI bases its knowledge and belief on information provided by third parties, and makes no representation or warranty as to the accuracy of such information. Efforts are underway to better integrate information from third parties. TI has taken and continues to take reasonable steps to provide representative and accurate information but may not have conducted destructive testing or chemical analysis on incoming materials and chemicals. TI and TI suppliers consider certain information to be proprietary, and thus CAS numbers and other limited information may not be available for release.

In no event shall TI's liability arising out of such information exceed the total purchase price of the TI part(s) at issue in this document sold by TI to Customer on an annual basis.

## TAPE AND REEL INFORMATION



### QUADRANT ASSIGNMENTS FOR PIN 1 ORIENTATION IN TAPE



\*All dimensions are nominal

Device	Package Type	Package Drawing	Pins	SPQ	Reel Diameter (mm)	Reel Width W1 (mm)	A0 (mm)	B0 (mm)	K0 (mm)	P1 (mm)	W (mm)	Pin1 Quadrant
ONET1141LRGER	VQFN	RGE	24	3000	330.0	12.4	4.3	4.3	1.5	8.0	12.0	Q2
ONET1141LRGET	VQFN	RGE	24	250	330.0	12.4	4.3	4.3	1.5	8.0	12.0	Q2

**TAPE AND REEL BOX DIMENSIONS**



\*All dimensions are nominal

Device	Package Type	Package Drawing	Pins	SPQ	Length (mm)	Width (mm)	Height (mm)
ONET1141LRGER	VQFN	RGE	24	3000	367.0	367.0	38.0
ONET1141LRGET	VQFN	RGE	24	250	367.0	367.0	38.0

**RGE 24**

**GENERIC PACKAGE VIEW**

**VQFN - 1 mm max height**

PLASTIC QUAD FLATPACK - NO LEAD

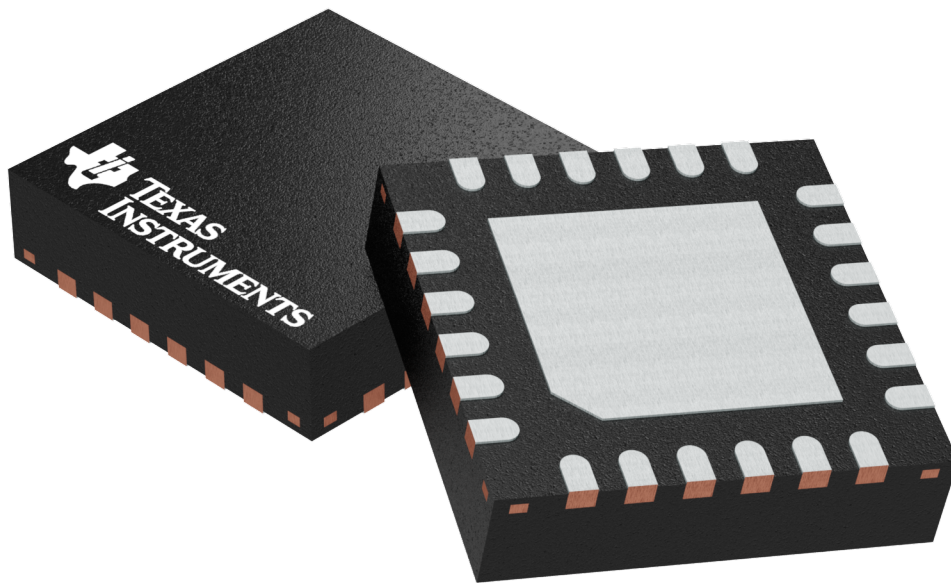

Images above are just a representation of the package family, actual package may vary.  
Refer to the product data sheet for package details.

4204104/H

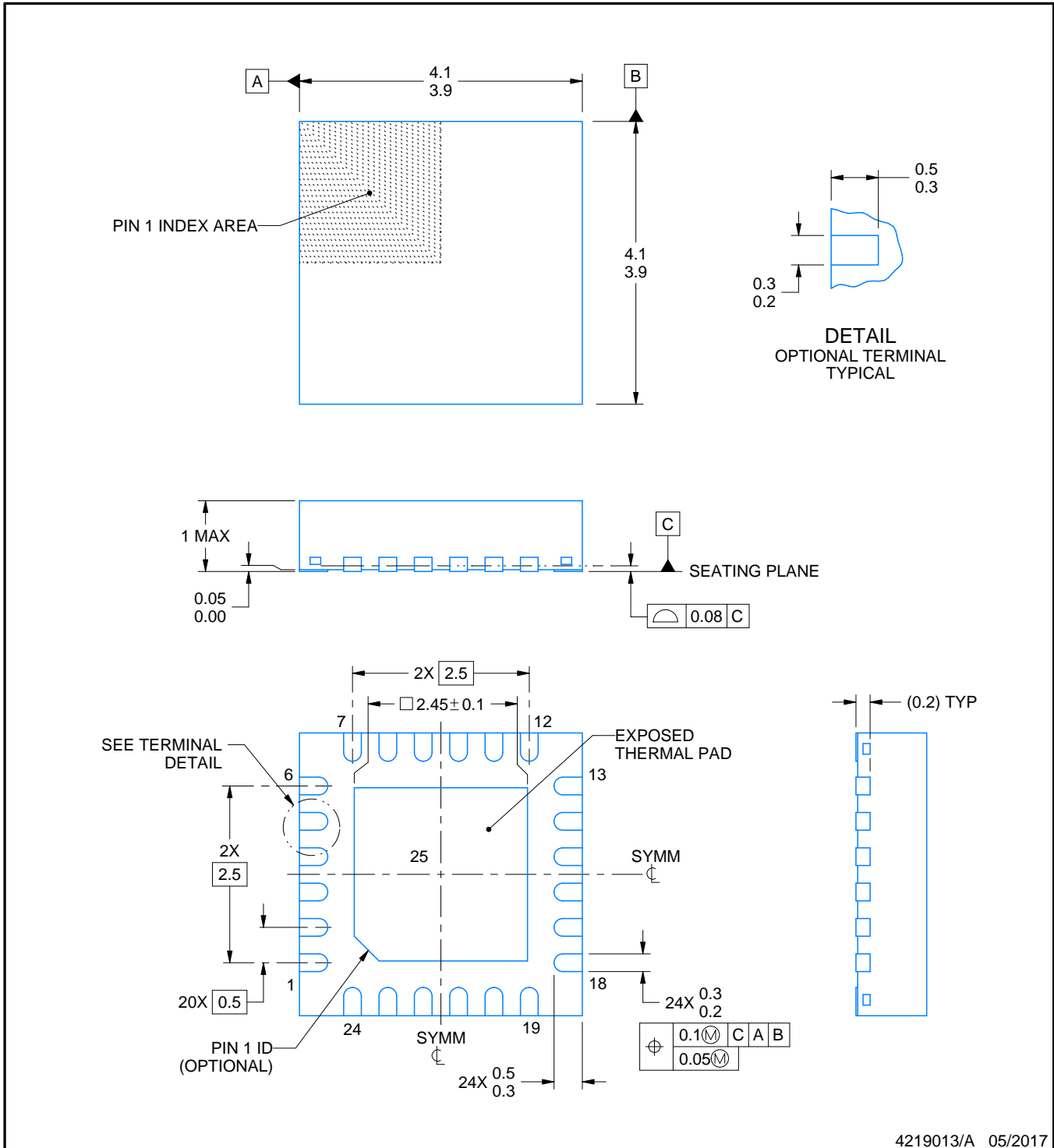
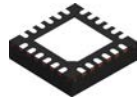

4219013/A 05/2017

NOTES:

1. All linear dimensions are in millimeters. Any dimensions in parenthesis are for reference only. Dimensioning and tolerancing per ASME Y14.5M.
2. This drawing is subject to change without notice.
3. The package thermal pad must be soldered to the printed circuit board for thermal and mechanical performance.



# EXAMPLE STENCIL DESIGN

RGE0024B

VQFN - 1 mm max height

PLASTIC QUAD FLATPACK - NO LEAD

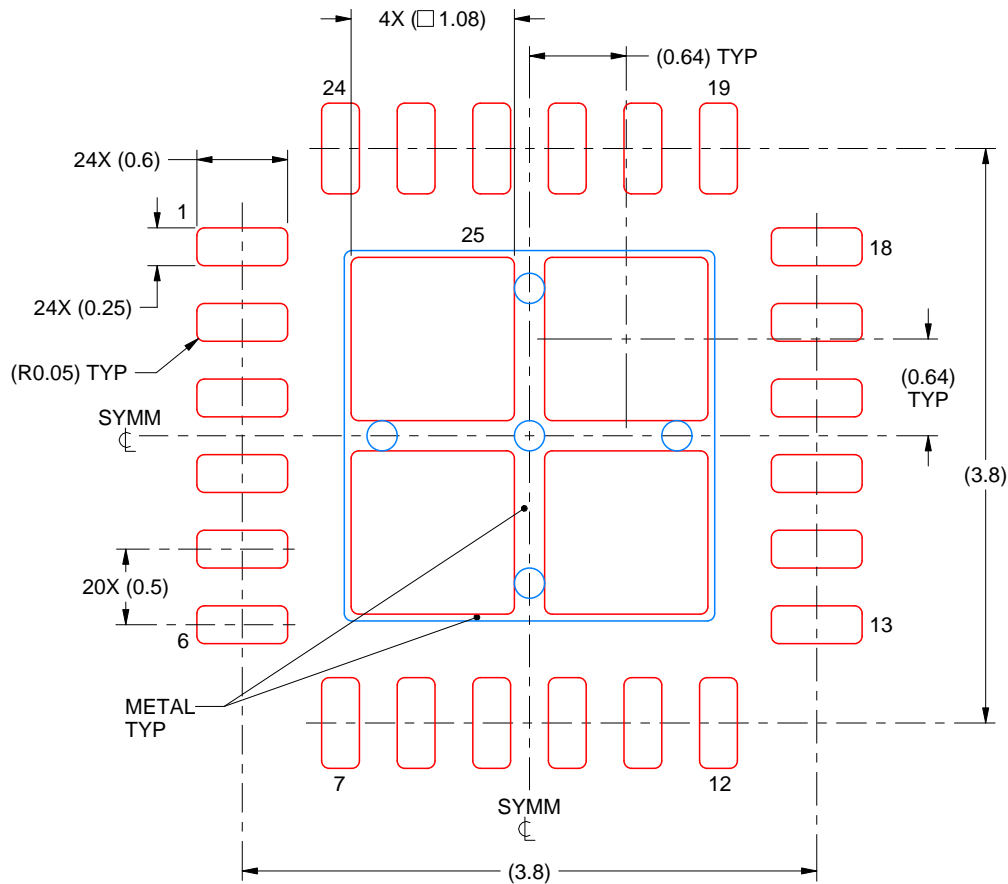

**SOLDER PASTE EXAMPLE**  
 BASED ON 0.125 mm THICK STENCIL

EXPOSED PAD 25  
 78% PRINTED SOLDER COVERAGE BY AREA UNDER PACKAGE  
 SCALE:20X

4219013/A 05/2017

NOTES: (continued)

- 6. Laser cutting apertures with trapezoidal walls and rounded corners may offer better paste release. IPC-7525 may have alternate design recommendations.

## IMPORTANT NOTICE

Texas Instruments Incorporated (TI) reserves the right to make corrections, enhancements, improvements and other changes to its semiconductor products and services per JESD46, latest issue, and to discontinue any product or service per JESD48, latest issue. Buyers should obtain the latest relevant information before placing orders and should verify that such information is current and complete.

TI's published terms of sale for semiconductor products (<http://www.ti.com/sc/docs/stdterms.htm>) apply to the sale of packaged integrated circuit products that TI has qualified and released to market. Additional terms may apply to the use or sale of other types of TI products and services.

Reproduction of significant portions of TI information in TI data sheets is permissible only if reproduction is without alteration and is accompanied by all associated warranties, conditions, limitations, and notices. TI is not responsible or liable for such reproduced documentation. Information of third parties may be subject to additional restrictions. Resale of TI products or services with statements different from or beyond the parameters stated by TI for that product or service voids all express and any implied warranties for the associated TI product or service and is an unfair and deceptive business practice. TI is not responsible or liable for any such statements.

Buyers and others who are developing systems that incorporate TI products (collectively, "Designers") understand and agree that Designers remain responsible for using their independent analysis, evaluation and judgment in designing their applications and that Designers have full and exclusive responsibility to assure the safety of Designers' applications and compliance of their applications (and of all TI products used in or for Designers' applications) with all applicable regulations, laws and other applicable requirements. Designer represents that, with respect to their applications, Designer has all the necessary expertise to create and implement safeguards that (1) anticipate dangerous consequences of failures, (2) monitor failures and their consequences, and (3) lessen the likelihood of failures that might cause harm and take appropriate actions. Designer agrees that prior to using or distributing any applications that include TI products, Designer will thoroughly test such applications and the functionality of such TI products as used in such applications.

TI's provision of technical, application or other design advice, quality characterization, reliability data or other services or information, including, but not limited to, reference designs and materials relating to evaluation modules, (collectively, "TI Resources") are intended to assist designers who are developing applications that incorporate TI products; by downloading, accessing or using TI Resources in any way, Designer (individually or, if Designer is acting on behalf of a company, Designer's company) agrees to use any particular TI Resource solely for this purpose and subject to the terms of this Notice.

TI's provision of TI Resources does not expand or otherwise alter TI's applicable published warranties or warranty disclaimers for TI products, and no additional obligations or liabilities arise from TI providing such TI Resources. TI reserves the right to make corrections, enhancements, improvements and other changes to its TI Resources. TI has not conducted any testing other than that specifically described in the published documentation for a particular TI Resource.

Designer is authorized to use, copy and modify any individual TI Resource only in connection with the development of applications that include the TI product(s) identified in such TI Resource. NO OTHER LICENSE, EXPRESS OR IMPLIED, BY ESTOPPEL OR OTHERWISE TO ANY OTHER TI INTELLECTUAL PROPERTY RIGHT, AND NO LICENSE TO ANY TECHNOLOGY OR INTELLECTUAL PROPERTY RIGHT OF TI OR ANY THIRD PARTY IS GRANTED HEREIN, including but not limited to any patent right, copyright, mask work right, or other intellectual property right relating to any combination, machine, or process in which TI products or services are used. Information regarding or referencing third-party products or services does not constitute a license to use such products or services, or a warranty or endorsement thereof. Use of TI Resources may require a license from a third party under the patents or other intellectual property of the third party, or a license from TI under the patents or other intellectual property of TI.

TI RESOURCES ARE PROVIDED "AS IS" AND WITH ALL FAULTS. TI DISCLAIMS ALL OTHER WARRANTIES OR REPRESENTATIONS, EXPRESS OR IMPLIED, REGARDING RESOURCES OR USE THEREOF, INCLUDING BUT NOT LIMITED TO ACCURACY OR COMPLETENESS, TITLE, ANY EPIDEMIC FAILURE WARRANTY AND ANY IMPLIED WARRANTIES OF MERCHANTABILITY, FITNESS FOR A PARTICULAR PURPOSE, AND NON-INFRINGEMENT OF ANY THIRD PARTY INTELLECTUAL PROPERTY RIGHTS. TI SHALL NOT BE LIABLE FOR AND SHALL NOT DEFEND OR INDEMNIFY DESIGNER AGAINST ANY CLAIM, INCLUDING BUT NOT LIMITED TO ANY INFRINGEMENT CLAIM THAT RELATES TO OR IS BASED ON ANY COMBINATION OF PRODUCTS EVEN IF DESCRIBED IN TI RESOURCES OR OTHERWISE. IN NO EVENT SHALL TI BE LIABLE FOR ANY ACTUAL, DIRECT, SPECIAL, COLLATERAL, INDIRECT, PUNITIVE, INCIDENTAL, CONSEQUENTIAL OR EXEMPLARY DAMAGES IN CONNECTION WITH OR ARISING OUT OF TI RESOURCES OR USE THEREOF, AND REGARDLESS OF WHETHER TI HAS BEEN ADVISED OF THE POSSIBILITY OF SUCH DAMAGES.

Unless TI has explicitly designated an individual product as meeting the requirements of a particular industry standard (e.g., ISO/TS 16949 and ISO 26262), TI is not responsible for any failure to meet such industry standard requirements.

Where TI specifically promotes products as facilitating functional safety or as compliant with industry functional safety standards, such products are intended to help enable customers to design and create their own applications that meet applicable functional safety standards and requirements. Using products in an application does not by itself establish any safety features in the application. Designers must ensure compliance with safety-related requirements and standards applicable to their applications. Designer may not use any TI products in life-critical medical equipment unless authorized officers of the parties have executed a special contract specifically governing such use. Life-critical medical equipment is medical equipment where failure of such equipment would cause serious bodily injury or death (e.g., life support, pacemakers, defibrillators, heart pumps, neurostimulators, and implantables). Such equipment includes, without limitation, all medical devices identified by the U.S. Food and Drug Administration as Class III devices and equivalent classifications outside the U.S.

TI may expressly designate certain products as completing a particular qualification (e.g., Q100, Military Grade, or Enhanced Product). Designers agree that it has the necessary expertise to select the product with the appropriate qualification designation for their applications and that proper product selection is at Designers' own risk. Designers are solely responsible for compliance with all legal and regulatory requirements in connection with such selection.

Designer will fully indemnify TI and its representatives against any damages, costs, losses, and/or liabilities arising out of Designer's non-compliance with the terms and provisions of this Notice.

## Looking for pricing, stock, or lifecycle information?

Click below to explore more details on WIN SOURCE:

 [View ONET1141LRGER](#) on WIN SOURCE

 [Texas Instruments](#) Information

## Optimize Your Supply Chain with WIN SOURCE Solutions

-  Global Sourcing Solution
-  Obsolete Management
-  Cost Control Management
-  Shortage Management
-  Alternative Solution
-  Excess Inventory Management