



**THE DATASHEET OF  
AS3543-ECTP**





**austriamicrosystems AG**

**is now**

**ams AG**

The technical content of this austriamicrosystems datasheet is still valid.

**Contact information:**

**Headquarters:**

ams AG

Tobelbaderstrasse 30

8141 Unterpremstaetten, Austria

Tel: +43 (0) 3136 500 0

e-Mail: [ams\\_sales@ams.com](mailto:ams_sales@ams.com)

Please visit our website at [www.ams.com](http://www.ams.com)

# AS3543

DataSheet

## High End Stereo Audio Codec with System PMU

### 1 General Description

The AS3543 is an ultra low power stereo audio codec and is designed for Portable Digital Audio Applications.

It allows high-end quality playback with up to 100dB SNR and recording in FM quality. With one microphone (including pre-amplifier and supply for an electret microphone) and two line inputs, it allows connecting a variety of audio inputs. The different audio signals can be mixed via a 6-channel mixer and fed to either a headphone output for 16 /32 headsets or a line output. Both outputs have a ground noise cancellation to use it e.g. in car docking stations. The audio outputs have also an auto fading implemented which performs the fade-in, fade-out as well as the transition between specific volume levels automatically with an selectable timing.

Further the device offers advanced power management functions. All necessary ICs and peripherals in a Digital Audio Player are supplied by the AS3543. It features 2 DCDC converters for core and memory/periphery supply as well as 4 LDOs. Both DCDC converter feature DVM (dynamic voltage management) with an selectable timing for the voltage stepping. The different regulated supply voltages are programmable via the serial control interface.

The step-up converter for the backlight can operate up to 15V (with an external transistor even higher) in voltage and current control mode. An internal voltage protection is limiting the output voltage in the case of external component failures. 2 high voltage current sinks can be used to operate two, if needed also unbalanced, LED strings. An automatic dimming function allows a logarithmic on/off of the backlight with selectable timing.

AS3543 also contains a Li-Ion battery charger with constant current, constant voltage and trickle charging. The maximum charging current is 460mA. An integrated battery switch is separating the battery during charging or whenever an external power supply is present. With this switch it is also possible to operate with no or deeply discharged batteries.

The AS3543 has an on-chip, phase locked loop (PLL) which generates the needed internal CODEC master clock. I2S Frame and shift-clock have to be applied from the processor for playback and recording.

Further the AS3543 has an independent 32kHz real time clock (RTC) on chip which allows a complete power down of the system CPU while only consuming less than 1µA. An internal switch automatically switches between the RTC backup-battery and main battery supply.

The single supply voltage may vary from 2.7V to 5.5V.

### 2 Key Features

#### Audio

##### Audio power consumption:

- - 5mW: 96dB DAC to Headphone @ 1.8V, 32Ω
- - 7mW: 100dB DAC to Headphone @ 2.9V, 32Ω

##### Sigma Delta Converters

- DAC
  - 98dB SNR ('A' weighted) @ 1.7V
  - 102dB SNR ('A' weighted) @ 2.9V
- ADC
  - 85dB SNR ('A' weighted) @ 1.7V
- Sampling Frequency
  - DAC: 8-96kHz
  - ADC: 8-24kHz

##### High Efficiency Headphone Amplifier

- volume control via serial interface
- 32 steps @1.5dB and MUTE
- 2x12mW @16Ω driver capability@ 1.8V supply
- THD -74dB @16Ω; 1.8V
- 2x40mW @16Ω driver capability@ 3.6V supply
- THD -77dB @16Ω; 3.6V
- headphone and over-current detection
- phantom ground eliminates large capacitors
- ground noise cancellation

##### Line Output

- volume control via serial interface
- 32 steps @1.5dB and MUTE
- 0.6Vp @10kΩ, 1.8V
- ground noise cancellation



## Microphone Input

- 3 gain pre-setting (30dB/36dB/42dB) and AGC
- 32 gain steps @1.5dB and MUTE
- supply for electret microphone
- microphone detection
- remote control by switch

## 2 Line Inputs

- volume control via serial interface
- 32 steps @1.5dB and MUTE
- stereo or 2x mono

## Audio Mixer

- 8 channel input/output mixer with AGC
- mixes line inputs, microphone and ADC with DAC
- left and right channels independent

## Power Management

### Voltage Generation

- step down for CPU core (0.61V-3.35V, 250mA)
- step down for peripheral (0.61V-3.35V, 250mA)
- LDO1 for AFE supply (1.7V (1.65-3.2V), 50mA)
- LDO2 for AFE supply (2.7V (2.3-3.5V), 200mA)
- LDO3 for peripherals (1.2V-3.5V, 100/200mA)
- LDO4 for peripherals (1.2V-3.5V, 100/200mA)
- VBUS comparator
- separate input for LDO3
- power supply supervision & hibernation modes
- 5sec and 10sec emergency shut-down

### Backlight Driver

- step up for backlight (15V (25V))
- current control mode (1.2-37.2mA)
- voltage control mode
- 2 HV current sinks
- automatic dimming
- over-voltage protection

### Battery Charger

- automatic trickle charge (55mA)
- prog. constant current charging (55-460mA)
- prog. constant voltage charging (3.9V-4.25V)
- current limitation for USB mode
- integrated battery switch

## General

### Supervisor

- automatic battery monitoring with interrupt generation and selectable warning level
- automatic temperature monitoring with interrupt generation and selectable warning and shutdown levels

### Real Time Clock

- ultra low power 32kHz oscillator
- 32bit RTC sec counter, 96 days auto wake-up
- selectable interrupt (seconds or minutes)
- 128bit free SRAM for random settings
- 32kHz clock output to peripheral
- voltage generation
- trim able oscillator
- <1uA total power consumption

### Auxiliary Oscillator (system clock generation)

- low power 12-24MHz oscillator
- clock output

### General Purpose ADC

- 10bit resolution
- 22 inputs analog multiplexer

### Interfaces

- 2 wire serial control interface
- reset pin with selectable delay, power good pin
- 64bit unique ID (OTP)
- 26 different interrupts
- Package CTBGA68 [6.0x6.0x1.1mm] 0.5mm pitch

## 3 Applications

Portable Digital Audio/Video Player and Recorder  
PDA, Smartphone

Figure 1. Block Diagram

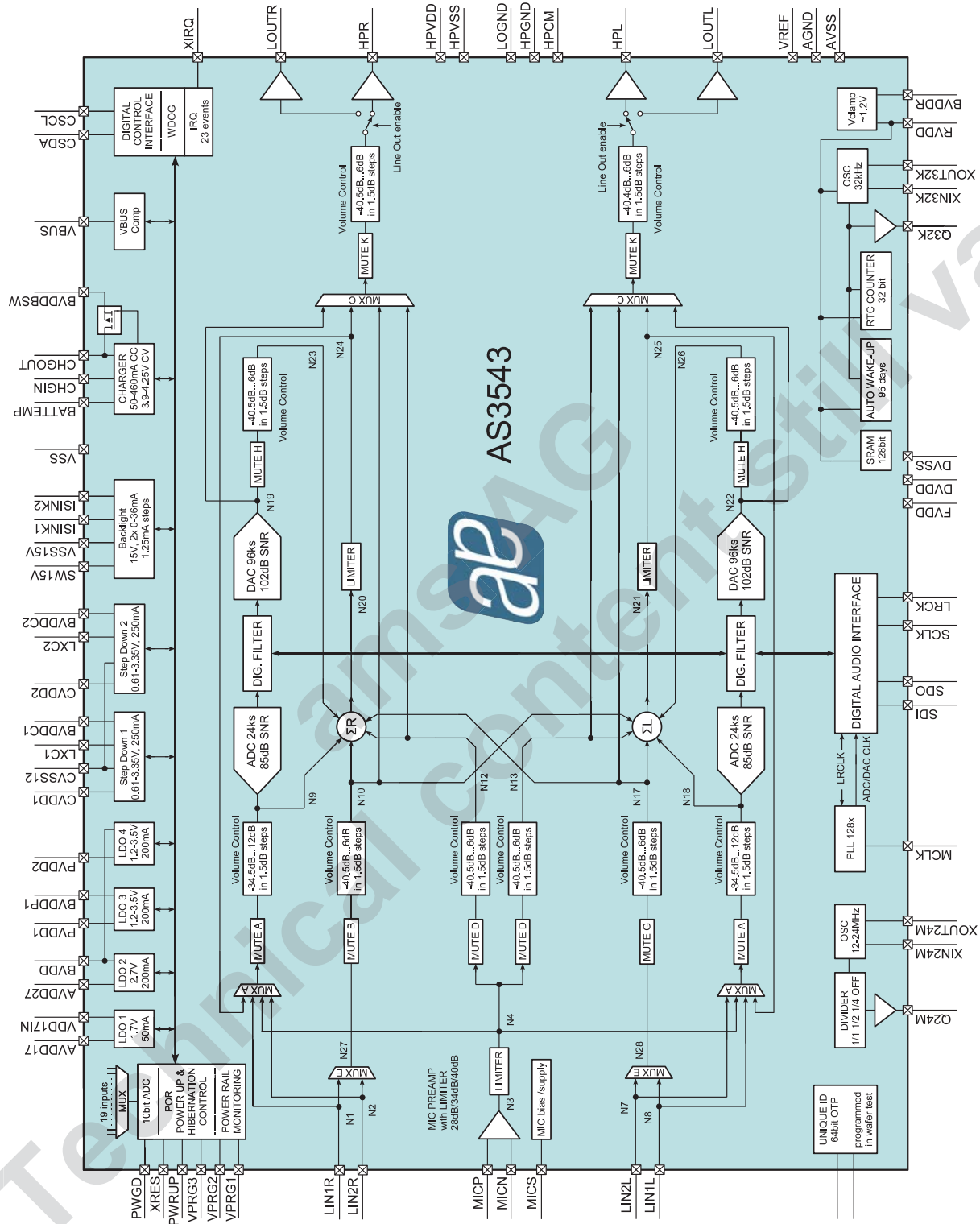

## Contents

<b>1 General Description</b>	<b>1</b>
<b>2 Key Features</b>	<b>1</b>
<b>3 Applications</b>	<b>2</b>
<b>4 Pinout</b>	<b>6</b>
4.1 Pin Assingment	6
4.2 Pin Description	6
<b>5 Absolute Maximum Ratings</b>	<b>9</b>
<b>6 Electrical Characteristics</b>	<b>11</b>
<b>7 Typical Operating Characteristics</b>	<b>13</b>
<b>8 Detailed Description - Audio Functions</b>	<b>14</b>
8.1 Audio Line Inputs (2x)	14
8.2 Microphone Input	15
8.3 Line Output	17
8.4 Headphone Output	18
8.5 DAC, ADC and I2S Digital Audio Interface	21
8.6 Audio Output Mixer	24
8.7 2-Wire-Serial Control Interface	25
<b>9 Detailed Description - Power Management Functions</b>	<b>28</b>
9.1 Low Drop Out Regulators	28
9.2 DCDC Step-Down Converter (2x)	31
9.3 15V Step-Up DCDC Converter	35
9.4 Charger	37
9.5 Battery Switch	40
<b>10 Detailed Description - SYSTEM Functions</b>	<b>41</b>
10.1 SYSTEM	41
10.2 Hibernation	43
10.3 Supervisor	44
10.4 Interrupt Generation	44
10.5 Real Time Clock	46
10.6 10-Bit ADC	47
10.7 GPIO Pins	48
10.8 12-24MHz Oscillator	49
10.9 Unique ID Code (64 bit OTP ROM)	50
<b>11 Register Definition</b>	<b>51</b>
<b>12 Application Information</b>	<b>88</b>
<b>13 Package Drawings and Markings</b>	<b>89</b>
<b>14 Ordering Information</b>	<b>90</b>

## Revision History

Table 1. Revision History

Revision	Date	Owner	Description
1.01	17.4.2009	pkm	official release
1.10	5.2009	pkm	added audio characterisation data
1.11	12.2012	pkm	typo and register bit description corrections

ams AG  
Technical content still valid

## 4 Pinout

### 4.1 Pin Assignment

Figure 2. Pin Assignments (Top View)

	1	2	3	4	5	6	7	8	9	10
A	CHGOUT	BVDDBSW	PVDD1		PVDD2	HPCM		HPR	HPVSS	HPL
B	CHGIN	BATTEMP	BVDDP1	BVDD	VDD17IN	HPGND	HPVDD	LOGND	LOUTR	LOUTL
C	VSS15V	SW15V							LIN1R	LIN1L
D		ISINK2		VSS	VBUS	LIN2R	LIN2L		MICS	
E	BVDDC2	ISINK1		MCLK			VPROG3		MICN	MICP
F	LXC2	CVDD2		SCLK			VPROG2		AGND	AVSS
G		FVDD		LRCK	SDI	SDO	VPROG1		VREF	
H	CVSS12	CVDD1							AVDD27	AVDD17
J	LXC1	PWRUP	XRES	XIRQ	PWGD	Q24M	Q32K	CACL	RVDD	XIN32K
K	BVDDC1	XIN24M	XOUT24M		DVSS	DVDD		CSDA	BVDDR	XOUT32K

### 4.2 Pin Description

Table 2. Pin Description for AS3543

Pin Number	Pin Name	Type	Description
K2	XIN24M	ANA IO	24MHz Crystal Input (ext. 22pF C needed)
K3	XOUT24M	ANA IO	24MHz Crystal Output (ext. 22pF C needed)
J2	PWRUP	DIG IN	Power Up Input
G2	FVDD	SUP IN	Digital Pos. Supply (e.g. DAC, ...)
J3	XRES	DIG OUT	Reset Output
J4	XIRQ	DIG OUT	Interrupt Request Output
J5	PWGD	DIG IO	PowerUp Sequence Complete Output
E4	MCLK	DIG IN	MCLK input
F4	SCLK	DIG IN	I2S Shift Clock Input
G4	LRCK	DIG IN	I2S Frame Clock Input
G5	SDI	DIG IN	I2S Data Input to DAC

Table 2. Pin Description for AS3543

Pin Number	Pin Name	Type	Description
K5	DVSS	GND	Digital Circuit Neg. Supply Terminal
K6	DVDD	SUP IN	Digital Periphery Pos. Supply
G6	SDO	DIG OUT	I2S Data Output from ADC
J6	Q24M	DIG IO	24MHz clock digital output
J7	Q32K	DIG IO	32kHz clock digital output
J8	CSCL	DIG IN	2 wire SERIF Clock Input
K8	CSDA	DIG IO	2 wire SERIF Data I/O
K9	BVDDR	SUP IN	Secondary RTC Supply - Supercap
K10	XOUT32K	ANA IO	32KHz Crystal Output XIN
J10	XIN32K	ANA IO	32kHz Crystal Input XOUT
J9	RVDD	ANA IO	RTC LDO output, RTC supply input
G9	VREF	ANA IO	DAC Reference Pin
G7	VPRG1	ANA IN	Core Supply Voltage Definition Pin
F7	VPRG2	ANA IN	Memory Supply Voltage Definition Pin
E7	VPRG3	ANA IN	PowerUp Sequence Definition Pin
F10	AVSS	GND	Ground (analog)
F9	AGND	ANA IO	Analog Common Mode Voltage Pin
E10	MICP	ANA IN	Microphone Input P
E9	MICN	ANA IN	Microphone Input N
D9	MICS	ANA IO	Microphone Supply Output / Remote Control input
D6	LIN2R	ANA IN	Analog Line Input 2 Right Channel
D7	LIN2L	ANA IN	Analog Line Input 2 Left Channel
B8	LOGND	ANA IO	Line Output Common Mode Voltage Pin
C9	LIN1R	ANA IO	Analog Line Input 1 Right Channel
B9	LOUTR	ANA OUT	Analog Line Output Right Channel
B10	LOUTL	ANA OUT	Analog Line Output Left Channel
C10	LIN1L	ANA IO	Analog Line Input 1 Right Channel
B7	HPVDD	SUP IN	Headphone Supply default 1.8V (max. 3.6V)
A10	HPL	ANA OUT	Headphone Output Left Channel
A8	HPR	ANA OUT	Headphone Output Right Channel
A6	HPCM	ANA OUT	Headphone Common Mode Buffer Pin
A9	HPVSS	GND	Headphone Ground
B6	HPGND	ANA IO	Headphone Common Mode Voltage Pin
H10	AVDD17	SUP IO	LDO1 Output default 1.7V
B5	VDD17IN	SUP IN	LDO1 Pos. Supply Terminal
H9	AVDD27	SUP IO	LDO2 Output default 2.7V
B4	BVDD	SUP IN	Main Battery Supply Input (2.7-5.5V)
D5	VBUS	ANA IN	VBUS Detection Input
A5	PVDD2	ANA OUT	LDO4 Output (PVDD2)
A3	PVDD1	ANA OUT	LDO3 Output (PVDD1)

Table 2. Pin Description for AS3543

Pin Number	Pin Name	Type	Description
B3	BVDDP1	SUP IN	LDO3 Pos. Supply Terminal
A2	BVDDBSW	SUP IO	Battery Switch output to be connected against BVDD
A1	CHGOUT	SUP IO	Li-Ion Charger Output (battery switch input)
B1	CHGIN	SUP IN	Li-Ion Charger Input
B2	BATTEMP	ANA IO	Li-Ion Charger Battery Temp. Sensor Input
D4	VSS	GND	Power Management Neg. Reference Supply
C1	VSS15V	GND	DCDC15V & Current Sinks Neg. Supply Terminal
C2	SW15V	DIG OUT	DCDC15V Switch Output to Coil
D2	ISINK2	ANA IO	DCDC15V Load Current Sink2 Terminal
E2	ISINK1	ANA IO	DCDC15V Load Current Sink1 Terminal
E1	BVDDC2	SUP IN	CVDD2 Step Down Pos. Supply Terminal
F1	LXC2	DIG OUT	CVDD2 Step Down Switch Output to Coil
F2	CVDD2	ANA IN	CVDD2 and Feedback Pin
H1	CVSS12	GND	DCDC12 Substrate Pin
H2	CVDD1	ANA IN	CVDD1 and Feedback Pin
J1	LXC1	DIG OUT	CVDD1 Step Down Switch Output to Coil
K1	BVDDC1	SUP IN	CVDD1 Step Down Pos. Supply Terminal

## 5 Absolute Maximum Ratings

Stresses beyond those listed in [Table 3](#) may cause permanent damage to the device. These are stress ratings only, and functional operation of the device at these or any other conditions beyond those indicated in [Electrical Characteristics on page 11](#) is not implied. Exposure to absolute maximum rating conditions for extended periods may affect device reliability. The device should be operated under recommended operating conditions.

Table 3. Absolute Maximum Ratings

Parameter	Min	Max	Units	Comments
5V pins	-0.5	7.0	V	Applicable for pins BVDD, BVDDC1, BVDDC2, BVDDR, BVDDP1, BVDDBSW, CHGIN, CHGOUT, VBUS, CSCL, CSDA, PWRUP
3V pins	-0.5	5.0	V	Applicable for pins DVDD, HPVDD, FVDD, VDD17IN, RVDD, VPRG1, VPRG2, VPRG3
15V pins	-0.5	17	V	Applicable for pin SW15V, ISINK1/2
Voltage difference at VSS terminals	-0.5	0.5	V	Applicable for pins VSS, VSS15V, CVSS12, HPVSS, AVSS, DVSS
3.3V pins with protection to AVDD27	-0.5	5.0 AVDD27	V	Applicable for pins BATTEMP, HPGND
3.3V pins with protection to DVDD	-0.5	5.0 DVDD+0.5	V	Applicable for pins MCLK, LRCK, SCLK, SDI, SDO, XIRQ, XRES, PWGD, Q32K, Q24M, XIN24M, XOUT24M
3.3V pins with protection to RVDD	-0.5	5.0 RVDD+0.5	V	Applicable for pins XIN32K, XOUT32K
3.3V pins with protection to AVDD17	-0.5	5.0 AVDD17+0.5	V	Applicable for pins LOU1L/R, LOGND, VREF, AGND, LIN1L/R, LIN2L/R, MICP/N, MICS
3.3V pins with protection to HPVDD	-0.5	5.0 HPVDD+0.5	V	Applicable for pins HPCM, HPR/L
voltage regulator pins with protection to BVDD	-0.5	5.0 BVDD+0.5	V	Applicable for pins AVDD27, PVDD1/2, CVDD1, LXC1, CVDD2, LXC2
voltage regulator pins with protection to AVDD17IN	-0.5	5.0 AVDD17IN +0.5	V	Applicable for pins AVDD17
Input Current (latch-up immunity)	-100	100	mA	Norm: JEDEC 17
<b>Continuous Power Dissipation (T<sub>A</sub> = +70°C)</b>				
Continuous power dissipation		500	mW	P <sub>T</sub> <sup>1</sup> for CTBGA68 package
<b>Electrostatic Discharge</b>				
Electrostatic Discharge HBM		+/-1	kV	Norm: JEDEC JESD22-A114C
<b>Temperature Ranges and Storage Conditions</b>				
Operating Temperature Range	-20	+85	°C	
Junction Temperature		+110	°C	
Storage Temperature Range	-50	+125	°C	
Humidity non-condensing	5	85	%	

Table 3. Absolute Maximum Ratings

Parameter	Min	Max	Units	Comments
<b>Bump Temperature (soldering)</b>				
Package Body Temperature		260	°C	Norm IPC/JEDEC J-STD-020C, reflects moisture sensitivity level only
Solder Profile	235	245	°C	peak temperature
	30	45	s	well time above 217 °C
Moisture Sensitive Level	3		1	Represents a max. floor live time of 168h

1. Depending on actual PCB layout and PCB used

## 6 Electrical Characteristics

BVDD=+2.7V...+5.5V,  $T_A$  =-20°C...+85°C. Typical values are at BVDD=+3.6V,  $T_A$ =+25°C, unless otherwise specified.

Table 4. Electrical Characteristics

Symbol	Parameter	Condition	Min	Typ	Max	Unit
<b>Supply Voltages</b>						
BVDDx	Battery Supply Voltage BVDD, BVDDBSW, BVDDC1, BVDDC2, BVDDP1		2.7	3.6	5.5	V
BVDDR	RTC secondary Supply Voltage		1.2		5.5	V
VBUS	USB VBUS Voltage			5.0	5.5	V
CHGIN	Charger Supply Voltage		4.5		5.5	V
HPVDD	HP Supply Voltage		1.8		3.6	V
DVDD	Digital Periphery Supply Voltage		1.8	2.9	3.6	V
VDD17IN	LDO1 Input Voltage		1.8		3.6	V
FVDD	Digital Supply Voltage		1.75	1.8	3.5	V
AVDD27	Analogue Supply Voltage		2.6	2.7	3.5	V
AVDD17	Analogue Supply Voltage		1.7	1.7	3.5	V
AGND	Analog Ground Voltage	Internally generated		AVDD17 /2		V
V <sub>DELTA-</sub>	Difference of Negative Supplies CVSS12, VSS15V, HPVSS, AVSS, DVSS, VSS	To achieve good performance, the negative supply terminals should be connected to low impedance ground plane.	-0.1		0.1	V
V <sub>DELTA+</sub>	Difference of Positive Supplies	RVDD-AVDD27; AVDD17-AVDD27; FVDD-AVDD27			0	V
		AVDD27-HPVDD			0.3	V
		BVDD-AVDD27			0.1	V
<b>POR &amp; Watchdog</b>						
V <sub>POR_ON</sub>	Power-on Reset Activation Level	Power-on Reset activation level when DVDD decreases		2.15		V
V <sub>POR_OFF</sub>	Power-on Reset Release Level	Power-on Reset release when DVDD increases		2.0		V
V <sub>POR_HY</sub>	Power-on Hysteresis			100		mV
f <sub>LRCLK_WD</sub>	LRCLK Watchdog		2	4.1	8	kHz
<b>PWRUP</b>						
t <sub>ON_DELAY</sub>	Delay Time of pin PWRUP	Minimum key press time		30		ms
V <sub>PWRUP_L</sub>	Input Level LOW,	Pin PWRUP, BVDD>3V			0.5	V
V <sub>PWRUP_H</sub>	Input Level HIGH	Pin PWRUP, BVDD>3V	BVDD/ 3			V
		Pin PWRUP, BVDD<=3V	1			V
I <sub>PWRUP</sub>	Internal Pull-down Current Source	Pin PWRUP; @2.9V	2.5	7	19	uA

Table 4. Electrical Characteristics (Continued)

Symbol	Parameter	Condition	Min	Typ	Max	Unit
<b>Digital Inputs/Outputs</b>						
V <sub>DO_DL</sub>	Digital Output Driver Capability (drive LOW)	Pins XRES, XIRQ, PWGD @ 8mA, SDO			10% DVDD	V
V <sub>DO_DH</sub>	Digital Output Driver Capability (drive HIGH)	Pins XRES, XIRQ @ 8mA, push/pull mode only, SDO	90% DVDD			V
I <sub>PU</sub>	Internal Pull-up Current Source	Pins XRES, XIRQ, PWGD, Q32K, Q24M; @0V		10		µA
V <sub>DI_L</sub>	Digital Input Level LOW	Pin SDI, SCLK, MCLK, LRCK		30% DVDD		V
V <sub>DI_H</sub>	Digital Input Level HIGH	Pin SDI, SCLK, MCLK, LRCK		70% DVDD		V
f <sub>CLK</sub>	Audio Clock Frequency	LRCK according to streamed audio data	8		96	kHz
<b>Block Power Requirements</b>						
I <sub>REF</sub>	Reference supply current	all blocks off, only LDO2 on		330		µA
I <sub>BIAS</sub>	Audio Bias current			32		µA
I <sub>SUM</sub>	Summing stage current			174		µA
I <sub>LIN</sub>	Line input stage current	no signal		146		µA
I <sub>MIC</sub>	Mic input stage current	no signal		643		µA
I <sub>MICS</sub>	Mic Supply stage current	no load		201		µA
I <sub>LOUT</sub>	Line output stage current	no load		436		µA
I <sub>DAC_GS</sub>	DAC gain stage current	no signal		214		µA
I <sub>ADC_GS</sub>	ADC gain stage current	no signal		1,36		mA
I <sub>HPH</sub>	Headphone stage current	1.8V, no load		1,94		mA
		Bias reduction on, no load		1,48		
		CM buffer off, no load		1,47		
		Bias reduction on, CM buffer off, no load		0,94		
I <sub>DAC</sub>	DAC supply current	LRCK=48kHz		1,48		mA
		LRCK=44.1kHz		1,41		
		LRCK=32kHz		1,19		
		LRCK=16kHz		0,91		
		LRCK=8kHz		0,76		
I <sub>ADC</sub>	ADC supply current	LRCK=24kHz		1,7		mA
		LRCK=22.05kHz		1,69		
		LRCK=16kHz		1,64		
		LRCK=8kHz		1,58		
		LRCK=4kHz		1,55		
I <sub>DAC-&gt;HP</sub>	DAC playback current	no load, 44.1kHz, including PMU				mA
I <sub>Line-&gt;HP</sub>	Line Input playback current	no load, including PMU				mA
I <sub>RTC</sub>	RTC supply current			600		nA

## 6.1 Audio Specification

BVDD=+3.6V, VDD27=HPVDD=FVDD=+3V, VDD17=+2.9V,  $f_s=48\text{kHz}$ ,  $T_A=+25^\circ\text{C}$ , unless otherwise specified.

Table 5. Electrical Characteristics

Symbol	Parameter	Condition	Min	Typ	Max	Unit
<b>DAC Input to Line Output</b>						
FS	Full Scale Output	$R_L=10\text{k}\Omega$ , $f=1\text{kHz}$ , $1V_{\text{RMS}}$ input		0,960		$V_{\text{RMS}}$
SNR	Signal to Noise Ratio	A-weighted, no load, silence input		100		dB
DR	Dynamic Range	A-weighted, no load, -60dB FS, $f=1\text{kHz}$		94		dB
THD	Total Harmonic Distortion	1kHz -1dB FS input, $R_L=10\text{k}\Omega$		-82		dB
CS	Channel Separation	$R_L=10\text{k}\Omega$		62		dB
<b>Line Input to Line Output</b>						
FS	Full Scale Output	$R_L=10\text{k}\Omega$ , $f=1\text{kHz}$ , $1V_{\text{RMS}}$ input		0,754		$V_{\text{RMS}}$
SNR	Signal to Noise Ratio	A-weighted, no load, silence input		101		dB
THD	Total Harmonic Distortion	1kHz $1V_{\text{RMS}}$ (-1dB FS) input, $R_L=10\text{k}\Omega$		-72		dB
CS	Channel Separation	$R_L=10\text{k}\Omega$		100		dB
<b>DAC Input to HP Output</b>						
FS	Full Scale Output	$R_L=32\Omega$		0,800		$V_{\text{RMS}}$
		$R_L=16\Omega$		0,793		$V_{\text{RMS}}$
SNR	Signal to Noise Ratio	A-weighted, no load, silence input		100		dB
DR	Dynamic Range	A-weighted, no load, -60dB FS, $f=1\text{kHz}$		89		dB
THD	Total Harmonic Distortion	no load, $f=1\text{kHz}$ , -1dB FS input		-80		dB
		$P_{\text{OUT}}=20\text{mW}$ , $R_L=32\Omega$ , $f=1\text{kHz}$ , -1dB FS		-79		dB
		$P_{\text{OUT}}=40\text{mW}$ , $R_L=16\Omega$ , $f=1\text{kHz}$ , -1dB FS		-78	-60	dB
CS	Channel Separation	$R_L=32\Omega$		-61		dB
		$R_L=16\Omega$		-60		dB
<b>Line Input to HP Output</b>						
FS	Full Scale Output	$R_L=32\Omega$ , $f=1\text{kHz}$ , $1V_{\text{RMS}}$ (FS) input		0,834		$V_{\text{RMS}}$
		$R_L=16\Omega$ , $f=1\text{kHz}$ , $1V_{\text{RMS}}$ (FS) input		0,827		$V_{\text{RMS}}$
SNR	Signal to Noise Ratio	A-weighted, no load, silence input		101		dB
THD	Total Harmonic Distortion	no load, $f=1\text{kHz}$ , $1V_{\text{RMS}}$		-72		dB
		$P_{\text{OUT}}=20\text{mW}$ , $R_L=32\Omega$ , $f=1\text{kHz}$ , $1V_{\text{RMS}}$		-72		dB
		$P_{\text{OUT}}=40\text{mW}$ , $R_L=16\Omega$ , $f=1\text{kHz}$ , $1V_{\text{RMS}}$		-72	-60	dB
CS	Channel Separation	$R_L=32\Omega$		84		dB
		$R_L=16\Omega$		72		dB
<b>Mic Input to Line Output</b>						
FS	Full Scale Output	$f=1\text{kHz}$ , $27\text{mV}_{\text{RMS}}$ FS input		0,950		$V_{\text{RMS}}$
SNR	Signal to Noise Ratio	A-weighted, no load, silence input		80		dB
THD	Total Harmonic Distortion	1kHz $27\text{mV}_{\text{RMS}}$ FS input		-77		dB
<b>Mic Input to ADC Output</b>						
SNR	Signal to Noise Ratio	A-weighted, no load, silence input		81		dB
DR	Dynamic Range	A-weighted, no load, -60dB FS, $f=1\text{kHz}$		84		dB
THD	Total Harmonic Distortion	1kHz $27\text{mV}_{\text{RMS}}$ FS input		-65		dB

BVDD=+3.6V, VDD27=+2.7V, HPVDD=VDD=1.8V, VDD17=+1.7V,  $f_S=48\text{kHz}$ ,  $T_A=+25^\circ\text{C}$ , unless otherwise specified.

Table 6. Electrical Characteristics

Symbol	Parameter	Condition	Min	Typ	Max	Unit
<b>DAC Input to Line Output</b>						
FS	Full Scale Output	$R_L = 10\text{k}\Omega$ , $f=1\text{kHz}$ , $1V_{\text{RMS}}$ input		0,568		$V_{\text{RMS}}$
SNR	Signal to Noise Ratio	A-weighted, no load, silence input		96		dB
DR	Dynamic Range	A-weighted, no load, -60dB FS, $f=1\text{kHz}$		95		dB
THD	Total Harmonic Distortion	1kHz -1dB FS input, $R_L=10\text{k}\Omega$		-90		dB
CS	Channel Separation	$R_L=10\text{k}\Omega$		62		dB
<b>Line Input to Line Output</b>						
FS	Full Scale Output	$R_L = 10\text{k}\Omega$ , $f=1\text{kHz}$ , $545mV_{\text{RMS}}$ input		0,545		$V_{\text{RMS}}$
SNR	Signal to Noise Ratio	A-weighted, no load, silence input		97		dB
THD	Total Harmonic Distortion	1kHz $1V_{\text{RMS}}$ (-1dB FS) input, $R_L=10\text{k}\Omega$		-81		dB
CS	Channel Separation	$R_L=10\text{k}\Omega$		100		dB
<b>DAC Input to HP Output</b>						
FS	Full Scale Output	$R_L=32\Omega$		0,560		$V_{\text{RMS}}$
		$R_L=16\Omega$		0,550		$V_{\text{RMS}}$
SNR	Signal to Noise Ratio	A-weighted, no load, silence input		97		dB
DR	Dynamic Range	A-weighted, no load, -60dB FS, $f=1\text{kHz}$		88		dB
THD	Total Harmonic Distortion	no load, $f=1\text{kHz}$ , FS input		-87		dB
		$P_{\text{OUT}}=6\text{mW}$ , $R_L=32\Omega$ , $f=1\text{kHz}$ , -1dB FS		-81		dB
		$P_{\text{OUT}}=12\text{mW}$ , $R_L=16\Omega$ , $f=1\text{kHz}$ , -1dB FS		-78	-60	dB
CS	Channel Separation	$R_L=32\Omega$		63		dB
		$R_L=16\Omega$		60		dB
<b>Line Input to HP Output</b>						
FS	Full Scale Output	$R_L = 32\Omega$ , $f=1\text{kHz}$ , $545mV_{\text{RMS}}$ (FS) input		0,450		$V_{\text{RMS}}$
		$R_L = 16\Omega$ , $f=1\text{kHz}$ , $545mV_{\text{RMS}}$ (FS) input		0,447		$V_{\text{RMS}}$
SNR	Signal to Noise Ratio	A-weighted, no load, silence input		97		dB
THD	Total Harmonic Distortion	no load, $f=1\text{kHz}$ , $545mV_{\text{RMS}}$		-77		dB
		$P_{\text{OUT}}=6\text{mW}$ , $R_L=32\Omega$ , $f=1\text{kHz}$ , $545mV_{\text{RMS}}$		-75		dB
		$P_{\text{OUT}}=12\text{mW}$ , $R_L=16\Omega$ , $f=1\text{kHz}$ , $545mV_{\text{RMS}}$		-75	-60	dB
CS	Channel Separation	$R_L = 32\Omega$		77		dB
		$R_L = 16\Omega$		66		dB
<b>Mic Input to Line Output</b>						
FS	Full Scale Output	$f=1\text{kHz}$ , $27mV_{\text{RMS}}$ FS input		0,512		$V_{\text{RMS}}$
SNR	Signal to Noise Ratio	A-weighted, no load, silence input		75		dB
THD	Total Harmonic Distortion	1kHz $27mV_{\text{RMS}}$ FS input		77		dB
<b>Mic Input to ADC Output</b>						
SNR	Signal to Noise Ratio	A-weighted, no load, silence input		77		dB
DR	Dynamic Range	A-weighted, no load, -60dB FS, $f=1\text{kHz}$		84		dB
THD	Total Harmonic Distortion	1kHz $27mV_{\text{RMS}}$ FS input		-64		dB

## 7 Typical Operating Characteristics

BVDD = +3.6V, T<sub>A</sub> = +25°C, unless otherwise specified.

ams AG  
Technical content still valid

## 8 Detailed Description - Audio Functions

### 8.1 Audio Line Inputs (2x)

#### 8.1.1 General

The chip features two identical line inputs. The blocks can work in 2x mono single ended or in stereo single ended mode.

The volume control has an independent gain regulation for left and right channel with 32 steps @ 1.5dB each and MUTE. The gain can be set from  $-40.5\text{dB}$  to  $+6\text{dB}$ . The stage is set to mute by default. If the line input is not enabled, the volume settings are set to their default values. Changing the volume and mute control can only be done after enabling the input.

Line Input 1 and 2 are sharing one gain stage.

Figure 3. Line Inputs

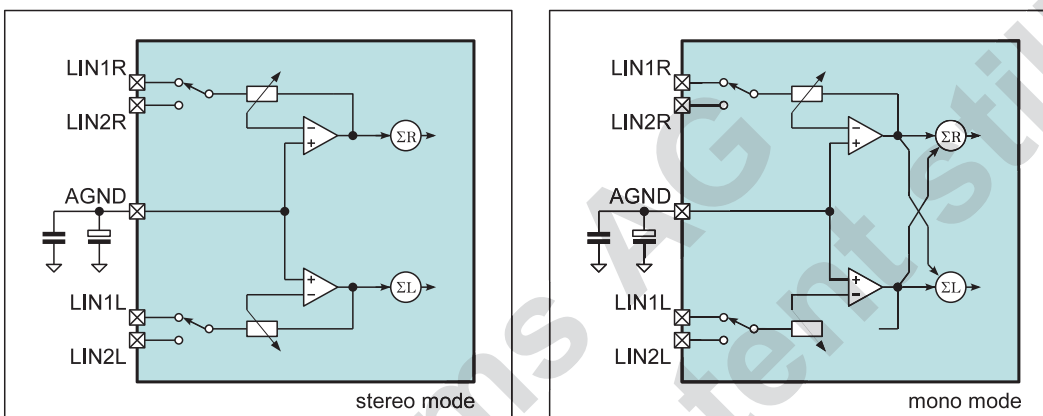

#### 8.1.2 Parameter

AVDD17=1.7V, AVDD27=2.7V,  $T_A=25^{\circ}\text{C}$ , unless otherwise mentioned

Table 7. Line Input Parameter

Symbol	Parameter	Condition	Min	Typ	Max	Unit
$V_{LIN}$	Input Signal Level	Pls observe gain settings. Max. peak levels at any node within the circuit shall not exceed AVDD		AVDD17 /3	AVDD17 /2	$V_{PEAK}$
$R_{LIN}$	Input Impedance	depending on gain setting		8-25		$k\Omega$
$\Delta R_{LIN}$	Input Impedance Tolerance			$\pm 30$		%
$C_{LIN}$	Input Capacitance			5		pF
$A_{LIN}$	Programmable Gain		-40.5		+6	dB
	Gain Steps	discrete logarithmic gain steps		1.5		dB
	Gain Step Accuracy			$\pm 0.25$		dB
$A_{LINMUTE}$	Mute Attenuation			100		dB

### 8.1.3 Register Description

Table 8. Line Input Related Register

Name	Base	Offset	Description
LINE_IN_R	2-wire serial	0Ah	Right Line Input 1/2 settings, Line Input 2 selection
LINE_IN_L	2-wire serial	0Bh	Left Line Input 1/2 settings
AudioSet1	2-wire serial	14h	Enable/disable driver stage
AudioSet3	2-wire serial	16h	Enable/disable mixer input

Line input has to be enabled in register 14h first before other settings in register 0Ah and 0Bh can be programmed.

## 8.2 Microphone Input

### 8.2.1 General

The AFE offers one microphone input and one low noise microphone voltage supply (microphone bias), voice activation, microphone connect detection and push button remote control.

Figure 4. Microphone Input

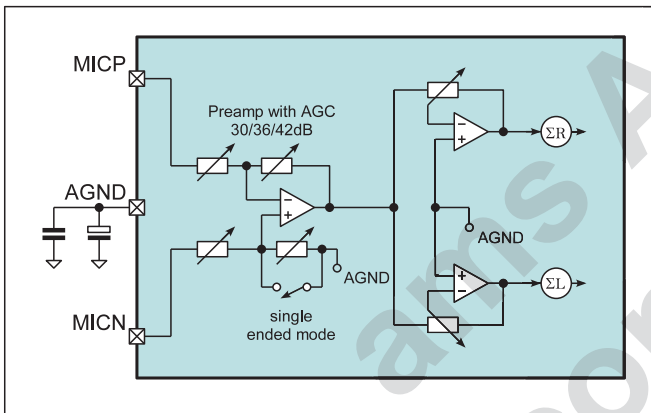

### 8.2.2 Gain Stage & Limiter

The integrated pre-amplifier allows 3 preset gain settings. There is also a limiter which attenuates high input signals from e.g. electret microphones signal to 1Vp. The AGC has 128 steps with 0.375dB with a dynamic range of the full pre-amplifier level. The AGC is ON by default but can be disabled by a microphone register bit.

Apart from the microphone pre-amplifier the microphone input signal can further be amplified with 32 @1.5dB programmable logarithmic gain steps and MUTE. All gains and MUTE are independently programmable. The gain can be set from -40.5dB to +6dB.

The stage features a soft-start function. Pre-amplifier and gain-stage settings can be set before enabling the microphone stage. After enabling the stage to gain is automatically set to the defined value by using the 128 steps of the AGC.

### 8.2.3 Supply & Detection

Each microphone input generates a supply voltage of 1.5V above HPCM. The supply is designed for  $\leq 2\text{mA}$  and has a 6.5mA current limit. In OFF mode the MICS terminal is pulled to AVDD with 20kOhm. A current of typically 50uA generates an interrupt to inform the CPU, that a circuit is connected. When using HPCM as headset ground the HP-stage gives the interrupt. After enabling the HP-stage through the CPU the microphone detection interrupt will follow.

When using the MICS terminal as ADC-10 input to monitor external voltages the 20kOhm pull-up has to be disabled by disabling the interrupt for microphone detection.

### 8.2.4 Remote Control

Fast changes of the supply current of typically 500uA are detected as a remote button press, and an interrupt is generated. Then the CPU can start the measurement of the microphone supply current with the internal 10-bit ADC to distinguish which button was pressed. As the current measurement is done via an internal resistor, only two buttons generating a current of about 0.5mA and 1mA can be detected. With this, 1mA as microphone bias is still available.

### 8.2.5 Voice Activation

Further a built-in voice activation comparator can actuate an interrupt if microphone input voltage of about 5mVRMS is detected.

### 8.2.6 Parameter

AVDD17=1.7V, AVDD27=2.7V, T<sub>A</sub>= 25°C unless otherwise mentioned

Table 9. Microphone Input Parameter

Symbol	Parameter	Condition	Min	Typ	Max	Unit
V <sub>MICIN0</sub>	Input Signal Level	A <sub>MICPRE</sub> = 30dB; A <sub>MIC</sub> = 0dB		20		mV <sub>P</sub>
V <sub>MICIN1</sub>		A <sub>MICPRE</sub> = 36dB; A <sub>MIC</sub> = 0dB		10		mV <sub>P</sub>
V <sub>MICIN2</sub>		A <sub>MICPRE</sub> = 42dB; A <sub>MIC</sub> = 0dB		5		mV <sub>P</sub>
R <sub>MICIN</sub>	Input Impedance	MICP, MICN to AGND		7.5		kΩ
Δ <sub>MICIN</sub>	Input Impedance Tolerance			-7 +33		%
C <sub>MICIN</sub>	Input Capacitance			5		pF
A <sub>MICPRE</sub>	Microphone Preamplifier Gain	Preamplifier has 3 selectable (fixed) gain settings		30 36 42		dB
A <sub>MIC</sub>	Programmable Gain		-40.5		+6	dB
	Gain Steps	discrete logarithmic gain steps		1.5		dB
	Gain Step Precision			±0.25		dB
V <sub>ATTACK</sub>	Limiter Activation Level			0.57		V <sub>PEAK</sub>
V <sub>DECAY</sub>	Limiter Release Level			0.47		V <sub>PEAK</sub>
A <sub>MICLIMIT</sub>	Limiter Gain Overdrive	128 @ 0.375dB		30 36 42		dB
t <sub>ATTACK</sub>	Limiter Attack Time			50		μs/6dB
t <sub>DECAY</sub>	Limiter Decay Time			120		ms/ 6dB
A <sub>MICMUTE</sub>	Mute Attenuation			100		dB
V <sub>MICSUP</sub>	Microphone Supply Voltage	depending on V_MICS setting		2 1.55 1.26 1.06		V
I <sub>MICMAX</sub>	Max. Microphone Supply Current	microphones nominally need a bias current of 0.5mA-1mA		6.5		mA
V <sub>NOISE</sub>	Microphone Supply Voltage Noise			5		μV
I <sub>MICDET</sub>	Microphone Detection Current			50		μA
I <sub>REMDDET</sub>	Max. Remote Detection Current			500		μA

## 8.2.7 Register Description

Table 10. Microphone Input Related Register

Name	Base	Offset	Description
MIC_R	2-wire serial	06h	Right Microphone Input volume settings, AGC control
MIC_L	2-wire serial	07h	Left Microphone Input volume settings, MIC supply control
AudioSet1	2-wire serial	14h	Enable/disable driver stage
AudioSet3	2-wire serial	16h	Enable/disable mixer input
IRQENRD_1	2-wire serial	24h	Interrupt settings for microphone voice activation
IRQENRD_3	2-wire serial	26h	Interrupt settings for microphone detection
IRQENRD_4	2-wire serial	27h	Interrupt settings for remote button press detection

## 8.3 Line Output

### 8.3.1 General

The line output is designed to provide the audio signal with a typical  $V_{PEAK}$  level at a load of minimum  $10k\Omega$ , which is a minimum value for line inputs. If the limiters (N20/N21) are deactivated the peak output voltage is  $AVDD17/2 V_p$ .

This AFE has a combined output stage for headphone and line output with an independent gain regulation for left and right channel with 32 steps @ 1.5dB each. The gain can be set from -40.5dB to +6dB.

If the line output is not enabled, the volume settings are set to their default values. Changing of volume and mute control can only be done after enabling the output.

Figure 5. Line Output

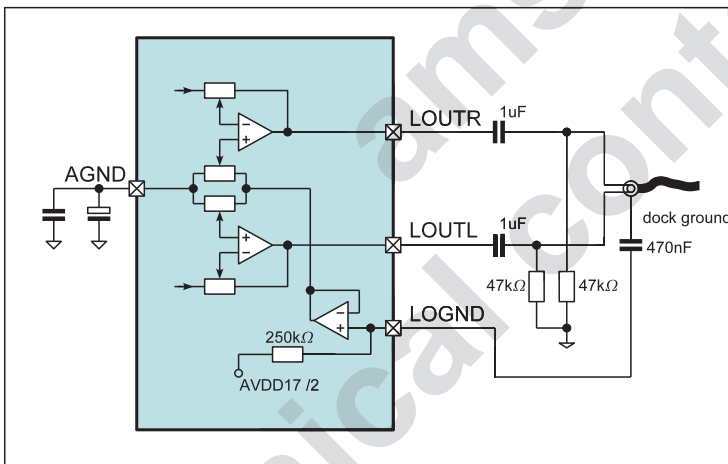

### 8.3.2 Auto Fading

By setting a new output volume level, the stage does an automatic fading from the current gain setting to the new target. Changing the input multiplexer from one source to another will be done by fading out to mute, source changing and fading in of the new source to the target volume. Change from HPH-out to LINE-out is done by fading out of HPH-out to mute and fading in of the LINE-out to the target volume.

The fading speed can be programmed to 3 different speed levels. The immediate response can be selected as 4th state.

### 8.3.3 Ground Noise Cancellation

A separate ground input allows to connect a ground sense line direct from the dock connector ground or line out jack shield to make the audio output independent from PCB ground noise.

### 8.3.4 Parameter

AVDD17=1.7, AVDD27=2.7,  $T_A=25^{\circ}\text{C}$ , unless otherwise mentioned

Table 11. Line Output Parameter

Symbol	Parameter	Condition	Min	Typ	Max	Unit
$R_{L\_LO}$	Load Impedance (Stereo Mode)	line inputs nominally have 10k $\Omega$	5			k $\Omega$
$C_{L\_LO}$	Load Capacitance (Stereo Mode)				100	pF
$A_{LO}$	Programmable Gain		-40.5		+6	dB
	Gain Steps	discrete logarithmic gain steps		1.5		dB
	Gain Step Accuracy			$\pm 0.25$		dB
$A_{LOMUTE}$	Mute Attenuation			100		dB

### 8.3.5 Register Description

Table 12. Line Output Related Register

Name	Base	Offset	Description
<a href="#">OUT_R</a>	2-wire serial	00h	Right Line Output volume settings, MUX control
<a href="#">OUT_L</a>	2-wire serial	01h	Left Line Output volume settings
<a href="#">AudioSet2</a>	2-wire serial	15h	Auto fading timing settings
<a href="#">AudioSet3</a>	2-wire serial	16h	Enable/disable mixer input

## 8.4 Headphone Output

The headphone output is designed to provide the audio signal with 2x40mW @ 16 $\Omega$  or 2x20mW @32 $\Omega$ , which are typical values for headphones.

This AFE has a combined output stage for headphone and line output with an independent gain regulation for left and right channel with 32 steps @ 1.5dB each. The gain can be set from -40.5dB to +6dB.

Figure 6. Headphone Output

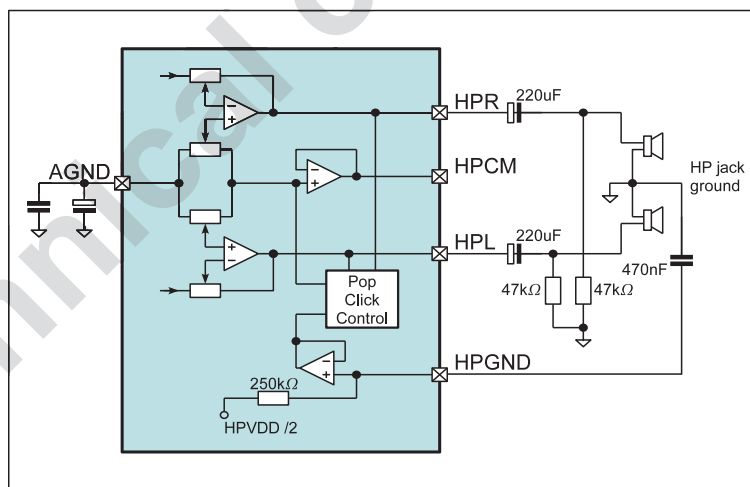

### 8.4.1 Phantom Ground

There are 2 ways to connect a headphone to the AFE. In order to spare the bulky ac/dc de-coupling capacitors at pins HPR/HPL a buffered ground (Phantom Ground) is provided. This Common Mode Buffer needs to be switched on if utilized. If form factor considerations are less stringent, the headphones can be conventionally connected via 2x200 $\mu$ F capacitors.

Figure 7. Headphone Output using Common Mode Buffer

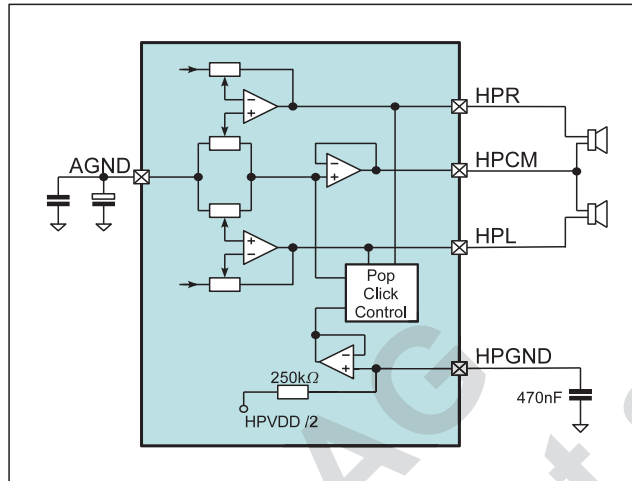

### 8.4.2 No-Pop Function

The output is automatically set to mute when the output stage is disabled.

To avoid Pop-Click noise during power-up and shut-down of the headphone amplifier, a charge/discharge control of HPGND (0V-HPVDD/2-0V) at pins HPR/HPL is incorporated into the AFE. The 470nF capacitor at pin HPGND is used to form the charge/discharge slope. Pls observe that pin HPGND is a high impedance node which must not be connected to any other external device than the 470nF buffer capacitor. To avoid Pop-Click noise one has to wait for 750ms in between a power-down (switch-off) and a power-up (switch-on) of the headphone amplifier.

### 8.4.3 Auto Fading

By setting a new output volume level, the stage does a automatic fading from the current gain setting to the new target. Changing the input multiplexer from one source to another will be done by fading out to mute, source changing and fading in of the new source to the target volume. Change from HPH-out to LINE-out is done by fading out of HPH-out to mute and fading in of the LINE-out to the target volume.

The fading speed can be programmed to 3 different speed levels. The immediate response can be selected as 4th state.

Figure 8. Headphone Startup with MaxGain Settings

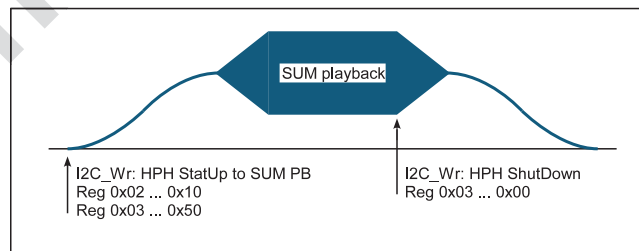
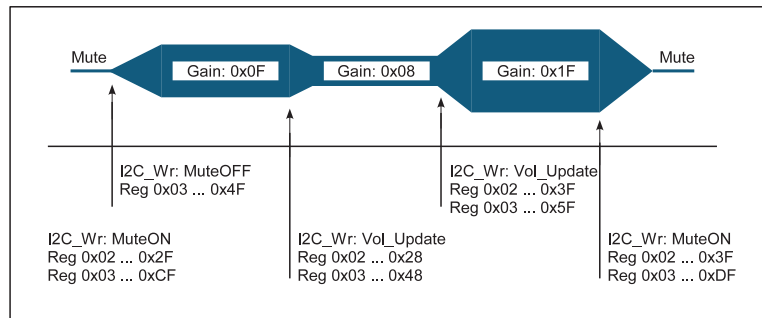

Figure 9. Headphone Change Gain Settings



#### 8.4.4 Headphone Detection

When the headphone amplifier is powered down, one can detect the connection of a headset. It only work if the headset is connected between pins HPR/HPL and HPCM. As long as the headphone amplifier is powered down, HPCM is biased to 150mV and acting as the sense pin. There is a corresponding interrupt available to be enabled.

#### 8.4.5 Over-current Protection

The headphone amplifier has an over-current protection (e.g. HPR/HPL is shorted). This over-current protection will power down the headphone amplifier for a programmable time-out period (512ms, 0ms). There is a corresponding interrupt available to be enabled.

Figure 10. Headphone Overcurrent OFF-ON Sequence

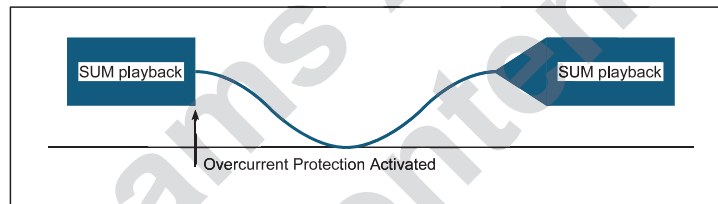

#### 8.4.6 Ground Noise Cancellation

As separate ground input allows to connect a ground sense line direct from the dock connector ground or headphone jack shield to make the audio output independent from PCB ground noise.

#### 8.4.7 Power Options

To save power, especially when driving 32 Ohm loads, a reduction of the bias current is selected. For 16Ohm loads the bias current can be increased.

#### 8.4.8 Parameter

AVDD17=1.7, AVDD27=2.7, HPVDD = 2.7V,  $T_A = 25^{\circ}\text{C}$ , unless otherwise mentioned

Table 13. Headphone Output Parameter

Symbol	Parameter	Condition	Min	Typ	Max	Unit
RL_HP	Load Impedance	stereo mode	16			$\Omega$
CL_HP	Load Capacitance	stereo mode			100	pF
P_HP	Nominal Output Power	RL=16 $\Omega$ , limiter enabled RL=32 $\Omega$ , limiter enabled		40 20		mW
A_HP	Programmable Gain		-40.5		+6	dB
	Gain Steps	discrete logarithmic gain steps		1.5		dB
	Gain Step Accuracy			$\pm 0.25$		dB

Table 13. Headphone Output Parameter (Continued)

Symbol	Parameter	Condition	Min	Typ	Max	Unit
	Over current limit	HPR/HPL pins HPCM pin, @1.8V		70mA 110mA		mA mA
	Over current limit	HPR/HPL pins HPCM pin, @2.7V		140mA 220mA		mA mA
P <sub>SRRHP</sub>	Power Supply Rejection Ratio	200Hz-20kHz, 720mVpp, RL=16Ω		90		dB
AHPMUTE	Mute Attenuation			100		dB

### 8.4.9 Register Description

Table 14. Headphone Related Register

Name	Base	Offset	Description
OUT_R	2-wire serial	02h	Right HP Output volume and over-current settings
OUT_L	2-wire serial	03h	Left HP Output volume settings, enable and detection control
AudioSet2	2-wire serial	15h	Auto fading timing settings
AudioSet3	2-wire serial	16h	Power options, common mode buffer enable
IRQENRD_3	2-wire serial	26h	Interrupt settings for over current and HP detection

## 8.5 DAC, ADC and I2S Digital Audio Interface

### 8.5.1 Input

The AFE receives serialized audio data for the DAC via pin SDI. The output of the DAC is fed through a volume control to the mixer stage and to the multiplexers of line output and headphone amplifiers or direct to these output stages.

This serialized audio data is a digital audio data stream with the left and the right audio channels multiplexed into one bit-stream. Via pin LRCK the alignment clock is input to the DAC digital filters. LRCK (Left Right Clock) indicates whether the serial bit-stream received via pin SDI, represents right channel or left channel audio data. Via pin SCLK the bit clock for the serial bit-stream is signalled. SDI and LRCK are synchronous with SCLK. SDI, LRCK and SCLK are inputs; SDO is not used.

The volume control has an independent gain regulation for left and right channel with 32 steps @ 1.5dB each. The gain can be set from -40.5dB to +6dB. The stage is set to mute by default. If the DAC input is not enabled, the volume settings are set to their default values. Changing the volume and mute control can only be done after enabling the input.

### 8.5.2 Output

This block consists of an audio multiplexer where the signal, which should be recorded, can be selected. The output is then fed through a volume control to the audio ADC. The digital output is done via an I2S interface.

The AFE sends serialized audio data from the ADC via pin SDO. This serialized audio data is a digital audio data stream with the left and the right audio channels multiplexed into one bit-stream. Via pin LRCK the alignment clock is signalled to the connected devices (e.g. CPU). LRCLK (Left Right Clock) indicates whether the serial bit-stream sent via pin SDI, presents right channel or left channel audio data. Via pin SCLK the bit clock for the serial bit-stream is signalled. SDO and LRCK are synchronous with SCLK. SDO is an output; LRCK and SCK are inputs; SDI is not used.

The volume control has an independent gain regulation for left and right channel with 32 steps @ 1.5dB each. The gain can be set from -34.5dB to +12dB. The stage is set to mute by default. If the ADC output is not enabled, the volume settings are set to their default values. Changing the volume and mute control can only be done after enabling the input.

The I2S output uses the same clocks as the I2S input. The sampling rate therefore depends also on the input sampling rate. The exact ratio can be set in register 11h.

The SDO output can be configured to operate in push/pull (3 different driver strengths) or to be tri-state. For a more detailed description of the GPIO functionality of this pin please refer to chapter [GPIO Pins on page 50](#).

### 8.5.3 I2S Modes

The AFE can be operated either in Slave Mode or in Slave Mode with the master clock directly signalled via pin MCLK. The master clock (MCLK) is the necessary internal over-sampling clock for the DAC and ADC (e.g.  $128 \cdot f_s$ ,  $f_s$ =audio sampling frequency)

In Slave Mode the PLL generates the master clock based on LRCK. Thus the PLL needs to be preset to the expected sampling frequency. The ranges are 8kS-23kS (8kHz-23kHz) and 24kS-48kS (24kHz-48kHz). Please refer to register 1A-7h.

Figure 11. I2S Modes

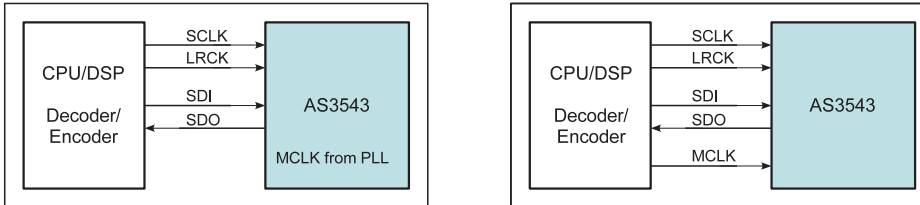

### 8.5.4 Clock Supervision

The digital audio interface automatically checks the LRCK. An interrupt can be generated when the state of the LRCK input changes. A bit in the interrupt register represents the actual state (present or not present) of the LRCK.

### 8.5.5 Signal Description

The digital audio interface uses the standard I2S format:

- left justified
- MSB first
- one additional leading bit

The on-chip synchronization circuit allows any bit-count up to 32bit. When there are less than 18 bits sampled, the data sample is completed with "0"s. In I2S direct mode the data length has to be minimum 18 bits.

The ADC output is always 14 bit. If more SCLK pulses are provided, only the first 14 will be significant. All following bits will be "0".

SCLK has not to be necessarily synchronous to LRCK but the high going edge has to be separate from LRCK edges. The LRCK signal has to be derived from a jitter-free clock source, because the on-chip PLL is generating a clock for the digital filter, which has to be always in correct phase lock condition to the external LRCK.

Please observe that LRCK has to be activated before enabling the ADC.

Figure 12. I2S left justified mode

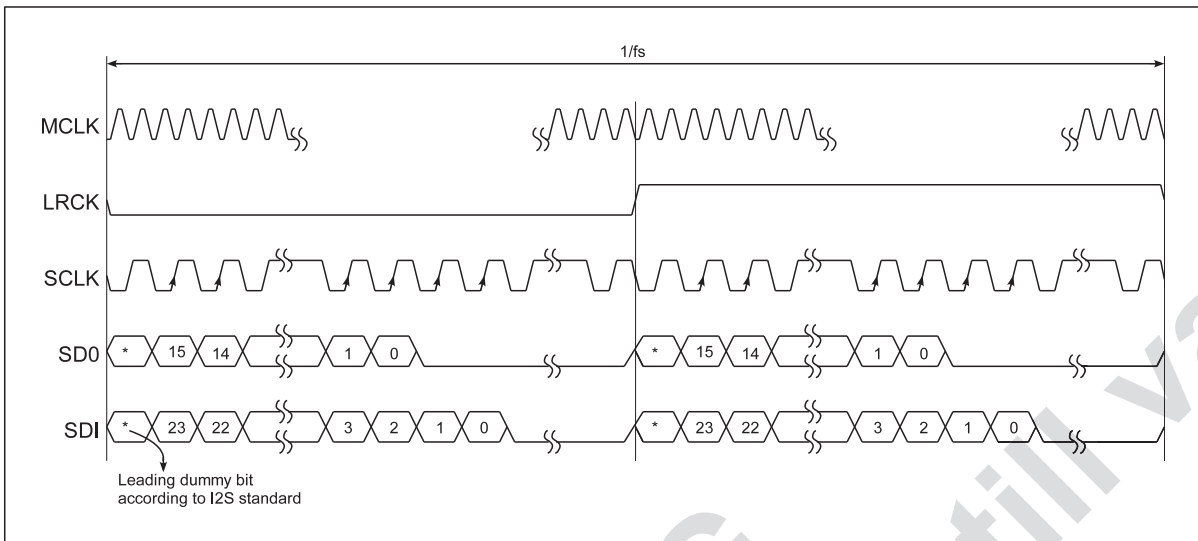

### 8.5.6 Parameter

DVDD=2.9V,  $T_A=25^\circ\text{C}$ , Slave Mode,  $f_s=48\text{kHz}$ ,  $\text{MCLK} = 128 \cdot f_s$ , unless otherwise specified

Table 15. I2S Timing

Symbol	Parameter	Condition	Min	Typ	Max	Unit
$t_{\text{SCLK}}$	SCLK Cycle Time		160			ns
$t_{\text{SCLKH}}$	SCLK Pulse Width High		80			ns
$t_{\text{SCLKL}}$	SCLK Pulse Width Low		80			ns
$T_{\text{LRSU}}$	LRCK Setup Time before SCLK rising edge		80			ns
$T_{\text{LRHD}}$	LRCK Hold Time after SCLK rising edge		80			ns
$t_{\text{SDSU}}$	SDI setup time before SCLK rising edge		25			ns
$t_{\text{SDHD}}$	SDI hold time after SCLK rising edge		25			ns
$t_{\text{SDOD}}$	SDO Delay from SCLK falling edge				25	ns
$t_{\text{JITTER}}$	Jitter of LRCK	internal PLL generates MCLK from LRCK	-20		20	ns
<b>I2S direct mode</b>						
$T_{\text{SCD}}$	SCLK delay after MCLK rising edge		0.5		1.5	ns
$T_{\text{LRD}}$	LRCK delay after SCLK rising edge		0.5		1.5	ns
$t_{\text{SDSU}}$	SDI setup time before SCLK rising edge		5			ns
$t_{\text{SDHD}}$	SDI hold time after SCLK rising edge		5			ns
$t_{\text{SDOD}}$	SDO Delay from SCLK falling edge				15	ns

## 8.5.7 Register Description

Table 16. Audio Converter Related Register

Name	Base	Offset	Description
DAC_R	2-wire serial	0Eh	DAC input volume settings
DAC_L	2-wire serial	0Fh	DAC input volume settings
ADC_R	2-wire serial	10h	ADC output volume settings, source multiplexer settings
ADC_L	2-wire serial	11h	ADC output volume settings, sampling rate settings
DAC_IF	2-wire serial	11h	DAC input digital volume settings
AudioSet1	2-wire serial	14h	Enable/disable DAC, DAC gain stage & ADC
AudioSet3	2-wire serial	16h	Enable/disable mixer input
Out_Cntr3	2-wire serial	1A-3h	Control of SDO signal and drive
PLL	2-wire serial	1A-7h	PLL sample rate settings
PMU_Enable	2-wire serial	1Ch	Enables writings to extended registers 1Ah-3 and 1Ah-7
IRQENRD_1	2-wire serial	25h	Interrupt settings for LRCK changes

DAC and ADC have to be enabled in register 14h first before other settings in register 0Eh to 11h can be programmed.

## 8.6 Audio Output Mixer

### 8.6.1 General

The mixer stage sums up the audio signals of the following stages

- Microphone Input 1
- Line Input 1/2
- DAC Output
- ADC Input

The mixing ratios have to be set within the volume registers of the corresponding input stages. Please be sure that the peak voltage of input signals for the mixer stage is less than  $AVDD17/3$ . If summing up several signals, each individual signal has of course to be accordingly lower. This shall insure that the output signal is also not higher than  $AVDD17/3$  peak to get a proper signal for the output amplifier.

This stage features an automatic gain control (AGC), which automatically avoids clipping.

### 8.6.2 Register Description

Table 17. Audio Mixer Related Register

Name	Base	Offset	Description
AudioSet2	2-wire serial	15h	Enable/disable mixer stage and AGC
AudioSet3	2-wire serial	16h	Enable/disable DAC, MIC or Line Inputs to mixer stage

## 8.7 2-Wire-Serial Control Interface

### 8.7.1 General

There is an I2C slave block implemented to have access to 64 byte of setting information.

The I2C address is: Adr\_Group8 - audio processors

- 8Ch\_write
- 8Dh\_read

### 8.7.2 Protocol

Table 18. 2-Wire Serial Symbol Definition

Symbol	Definition	RW	Note
S	Start condition after stop	R	1 bit
Sr	Repeated start	R	1 bit
DW	Device address for write	R	1000 1100b (8Ch)
DR	Device address for read	R	1000 1101b 8Dh)
WA	Word address	R	8 bit
A	Acknowledge	W	1 bit
N	No Acknowledge	R	1 bit
reg_data	Register data/write	R	8 bit
data (n)	Register data/read	W	8 bit
P	Stop condition	R	1 bit
WA++	Increment word address internally	R	during acknowledge
	AS3543 (=slave) receives data		
	AS3543 (=slave) transmits data		

Figure 13. Byte Write

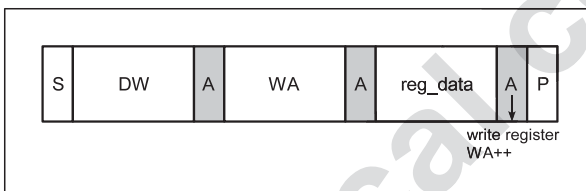
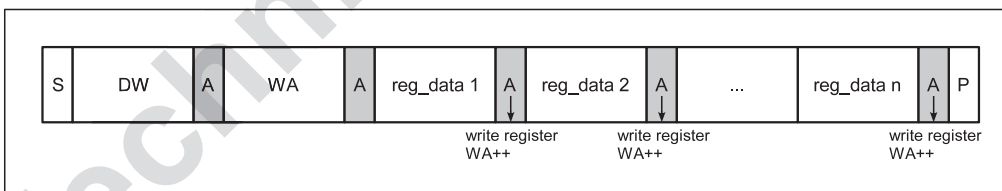

Figure 14. Page Write



Byte Write and Page Write formats are used to write data to the slave.

The transmission begins with the START condition, which is generated by the master when the bus is in IDLE state (the bus is free). The device-write address is followed by the word address. After the word address any number of data bytes can be sent to the slave. The word address is incremented internally, in order to write subsequent data bytes on subsequent address locations.

For reading data from the slave device, the master has to change the transfer direction. This can be done either with a repeated START condition followed by the device-read address, or simply with a new transmission START followed by the device-read address, when the bus is in IDLE state. The device-read address is always followed by the 1st register byte transmitted from the slave. In Read Mode any number of subsequent register bytes can be read from the slave. The word address is incremented internally.

Figure 15. Random Read

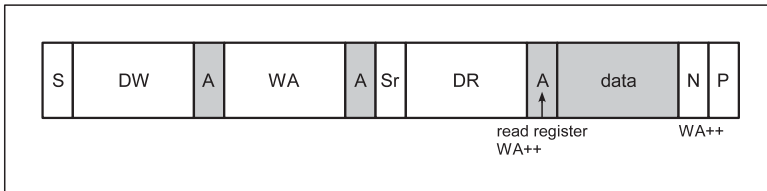

Random Read and Sequential Read are combined formats. The repeated START condition is used to change the direction after the data transfer from the master.

The word address transfer is initiated with a START condition issued by the master while the bus is idle. The START condition is followed by the device-write address and the word address.

In order to change the data direction a repeated START condition is issued on the 1st SCL pulse after the acknowledge bit of the word address transfer. After the reception of the device-read address, the slave becomes the transmitter. In this state the slave transmits register data located by the previous received word address vector. The master responds to the data byte with a not-acknowledge, and issues a STOP condition on the bus.

Figure 16. Sequential Read

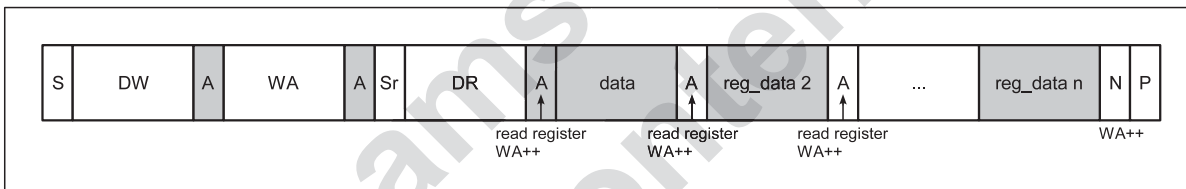

Sequential Read is the extended form of Random Read, as more than one register-data bytes are transferred subsequently. In difference to the Random Read, for a sequential read the transferred register-data bytes are responded by an acknowledge from the master. The number of data bytes transferred in one sequence is unlimited (consider the behavior of the word-address counter). To terminate the transmission the master has to send a not-acknowledge following the last data byte and generate the STOP condition subsequently.

Figure 17. Current Address Read

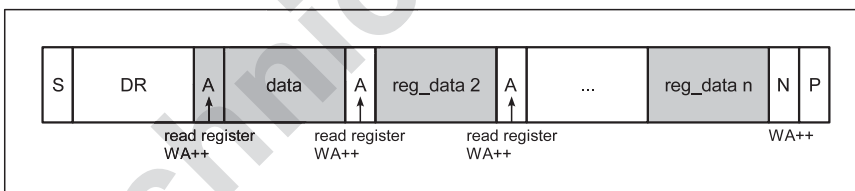

To keep the access time as small as possible, this format allows a read access without the word address transfer in advance to the data transfer. The bus is idle and the master issues a START condition followed by the Device-Read address. Analogous to Random Read, a single byte transfer is terminated with a not-acknowledge after the 1st register byte. Analogous to Sequential Read an unlimited number of data bytes can be transferred, where the data bytes has to be responded with an acknowledge from the master. For termination of the transmission the master sends a not-acknowledge following the last data byte and a subsequent STOP condition.

### 8.7.3 Parameter

Figure 18. 2-Wire Serial Timing

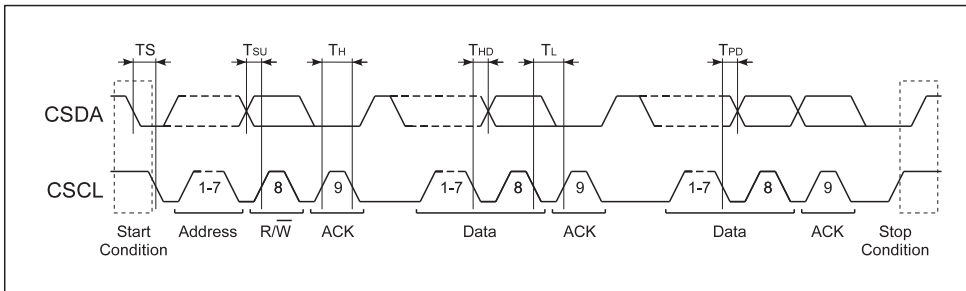

DVDD =2.9V,  $T_{amb}=25^{\circ}\text{C}$ ; unless otherwise specified

Table 19. 2-Wire Serial Parameter

Symbol	Parameter	Condition	Min	Typ	Max	Unit
$V_{CSL}$	CSCL, CSDA Low Input Level	(max 30%DVDD)	0	-	0.87	V
$V_{CSH}$	CSCL, CSDA High Input Level	CSCL, CSDA (min 70%DVDD)	2.03	-	5.5	V
HYST	CSCL, CSDA Input Hysteresis		200	450	800	mV
$V_{OL}$	CSDA Low Output Level	at 3mA	-	-	0.4	V
$T_{sp}$	Spike insensitivity		50	100	-	ns
$T_H$	Clock high time	max. 400kHz clock speed	500			ns
$T_L$	Clock low time	max. 400kHz clock speed	500			ns
$T_{SU}$		CSDA has to change Tsetup before rising edge of CSCL	250	-	-	ns
$T_{HD}$		No hold time needed for CSDA relative to rising edge of CSCL	0	-	-	ns
TS		CSDA H hold time relative to CSDA edge for start/stop/rep_start	200	-	-	ns
$T_{PD}$		CSDA prop delay relative to lowgoing edge of CSCL		50		ns

## 9 Detailed Description - Power Management Functions

### 9.1 Low Drop Out Regulators

#### 9.1.1 General

These LDOs are designed to supply sensitive analogue circuits, audio devices, AD and DA converters, micro-controller and other peripheral devices. The design is optimized to deliver the best compromise between quiescent current and regulator performance for battery powered devices.

Stability is guaranteed with ceramic output capacitors of  $1\mu\text{F} \pm 20\%$  (X5R) or  $2.2\mu\text{F} +100/-50\%$  (Z5U). The low ESR of these caps ensures low output impedance at high frequencies. Regulation performance is excellent even under low dropout conditions, when the power transistor has to operate in linear mode. Power supply rejection is high enough to suppress high ripple on the battery at the output. The low noise performance allows direct connection of noise sensitive circuits without additional filtering networks. The low impedance of the power device enables the device to deliver up to 150mA even at nearly discharged batteries without any decrease of performance.

Figure 19. LDO Block Diagram

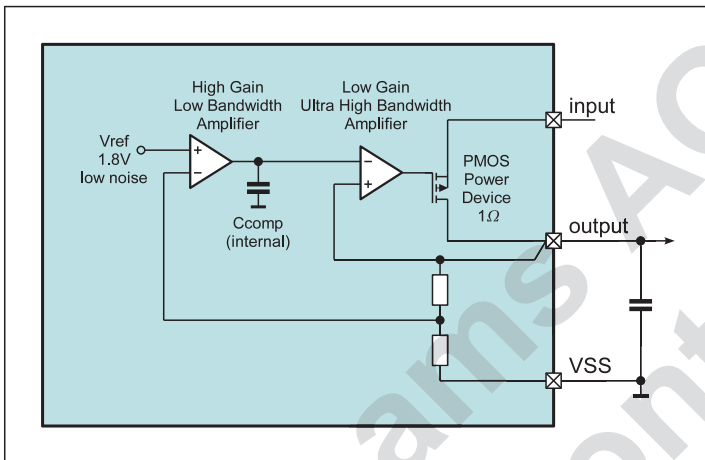

#### 9.1.2 LDO1

This LDO generates the audio supply voltage used for the AFE itself.

- Input voltage is VDD17IN
- Output voltage is AVDD17 (typ. 1.7V)
- Driver strength: 50mA

It is set to a default output voltage of 1.7V,  $50\text{mA}_{\text{max}}$ . It supplies the analog audio blocks of the AFE. Additional external loads are possible but most not exceed the supply ratings in total together with the operating internal blocks. Further the external load must not induce noise to the sensitive AVDD17 supply pin.

#### 9.1.3 LDO2

This LDO generates the digital and audio supply voltage used for the AFE itself.

- Input Voltage is BVDD
- Output Voltage is AVDD27 (typ. 2.7V)
- Driver strength: 100mA, can be programmed to 200mA

It is set to a default output voltage of 2.7V,  $100\text{mA}_{\text{max}}$ . It supplies the digital part of the AFE as well as all audio switches and multiplexers. Additional external loads are possible but most not exceed the supply ratings in total together with the operating internal blocks. Further the external load must not induce noise to the AVDD27 supply pin but is not as critical as AVDD17.

### 9.1.4 LDO3 & LDO4

These LDOs can be used to generate the periphery voltage for the digital processor or other external components (e.g. ext. DAC, USB-PHY, SD-Cards, NAND-Flashes, FM-Tuner ...)

LDO3 has a separate input pin (BVDDP1) which can be connected to either the battery or a DCDC converter output.

- Input Voltage BVDDP1 or BVDD
- Output Voltage is PVDD1 & PVDD2 (1.2 to 3.5V)
- Default value at start-up is defined by VPRG2 pin
- Driver strength: 100mA, can be programmed to 200mA

### 9.1.5 Parameter

BVDD=3.6V,  $T_A=25^{\circ}\text{C}$ , unless otherwise mentioned

Table 20. LDO Parameter

Symbol	Parameter	Condition	Min	Typ	Max	Unit
$R_{ON}$	On resistance				1	$\Omega$
PSRR	Power supply rejection ratio	f=1kHz		70		dB
		f=100kHz		40		
$I_{OFF}$	Shut down current			100		nA
$I_{VDD}$	Supply current	without load		50		$\mu\text{A}$
Noise	Output noise	10Hz < f < 100kHz		50		$\mu\text{V}_{\text{rms}}$
$t_{\text{start}}$	Startup time			200		$\mu\text{s}$
$V_{\text{out\_tol}}$	Output voltage tolerance	minimum +/- 50mV	-2.5%		2.5%	mV
$V_{\text{LineReg}}$	Line regulation	LDO2, Static		<1		mV
		LDO2, Transient; Slope: $t_r=10\mu\text{s}$		<10		
$V_{\text{LoadReg}}$	Load regulation	LDO2, Static		<1		mV
		LDO2, Transient; Slope: $t_r=10\mu\text{s}$		<10		
$I_{\text{LIMIT}}$	Current limitation	LDO1		100		mA
		LDO2, LDO3, LDO4		200		
		LDO2, LDO3 and LDO4, has to be enabled via register 18h-1, 18h-2, 18h-3		350		

Figure 20. LDO Block Diagram

Load regulation

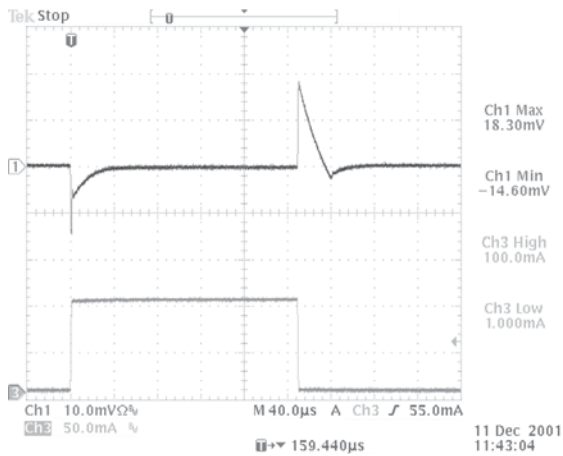

transient load: 1mA – 100mA slope: 1µs

Output noise

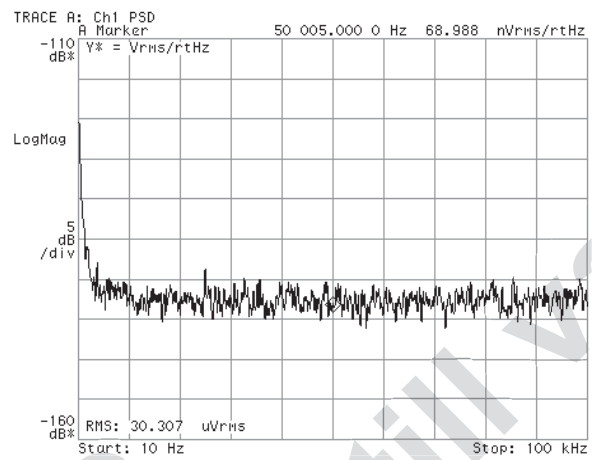

Output load: 150mA

Load Regulation

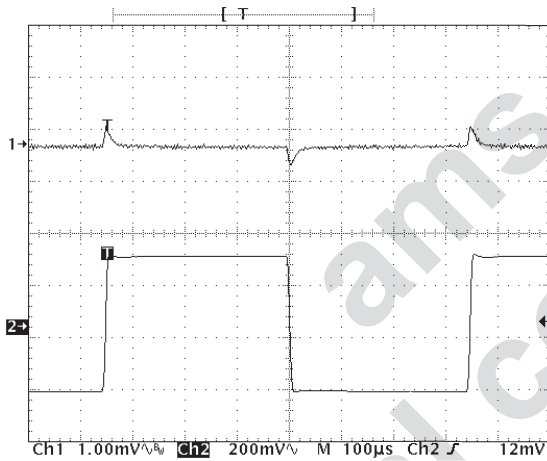

output load: 10mA  
transient input voltage ripple: 500mV

Load Regulation

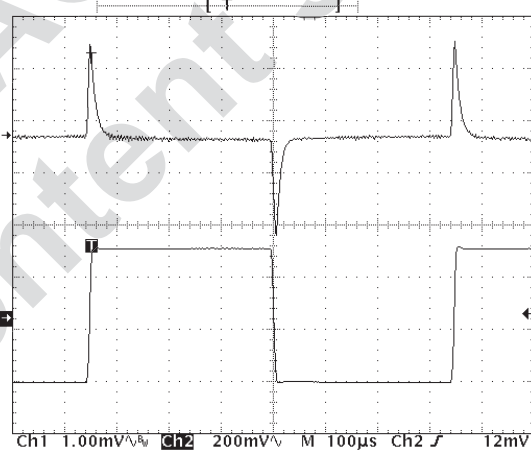

output load: 150mA  
transient input voltage ripple: 500mV

### 9.1.6 Register Description

Table 21. LDO Related Register

Name	Base	Offset	Description
PVDD1	2-wire serial	18h-1	PVDD1 (LDO3) control and voltage settings
PVDD2	2-wire serial	18h-2	PVDD2 (LDO4) control and voltage settings
AVDD27	2-wire serial	18h-6	AVDD27 (LDO2) control and voltage settings
AVDD17	2-wire serial	18h-7	AVDD17 (LDO1) control and voltage settings
PMU_Enable	2-wire serial	1Ch	Enables writings to extended registers 18h-1 to 18h-7

## 9.2 DCDC Step-Down Converter (2x)

### 9.2.1 General

These converters are meant to convert the battery voltage down to voltages which fit to the core and peripheral supply voltage requirements for microprocessors.

- input Voltage BVDDC1/2 (usually connected to the battery)
- output Voltage CVDD1 & CVDD2
- output voltage levels can be programmed independently from 0.61V to 3.35V
- the default value at start-up is defined by VPRG1 and VPRG2 pin
- DVM for both outputs with selectable timings
- driver strength 250mA
- under- and over-voltage detection

Figure 21. DCDC Step-Down Block Diagram

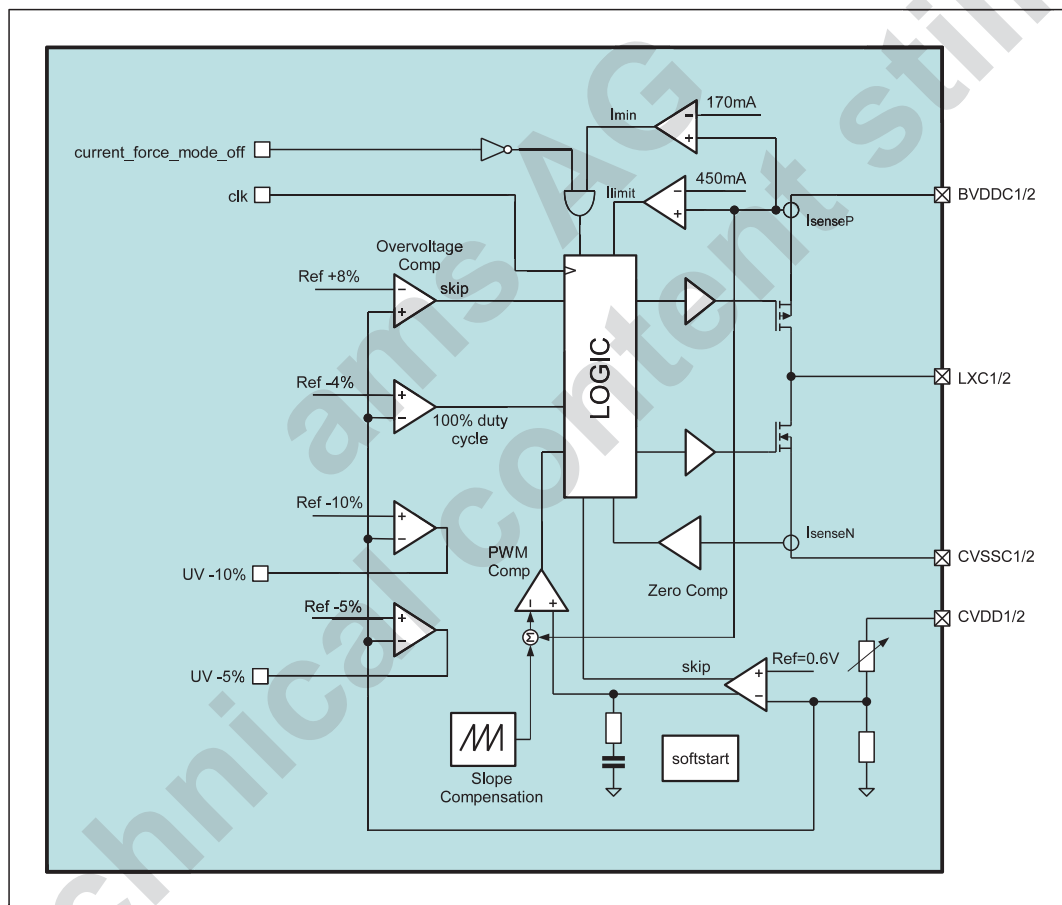

### 9.2.2 Functional Description

The step-down converter is a high efficiency fixed frequency current mode regulator. By using low resistance internal PMOS and NMOS switches efficiency up to 97% can be achieved. The fast switching frequency allows using small inductors, without increasing the current ripple. The unique feedback and regulation circuit guarantees optimum load and line regulation over the whole output voltage range, up to an output current of 250mA, with an output capacitor of only 10 $\mu$ F. The implemented current limitation protects the DCDC and the coil during overload condition.

To achieve optimized performance in different applications, adjustable settings allow to compromise between high efficiency and low input, output ripple:

### Low ripple, low noise operation:

In this mode there is no minimum coil current necessary before switching off the PMOS. As result, the ON time of the PMOS will be reduced down to  $t_{min\_on}$  at no or light load conditions, even if the coil current is very small or the coil current is inverted. This results in a very low ripple and noise, but decreased efficiency, at light loads, especially at low input to output voltage differences. In the case of an inverted coil current the regulator will not operate in pulse skip mode.

Figure 22. DCDC buck with disabled current force / pulse skip mode

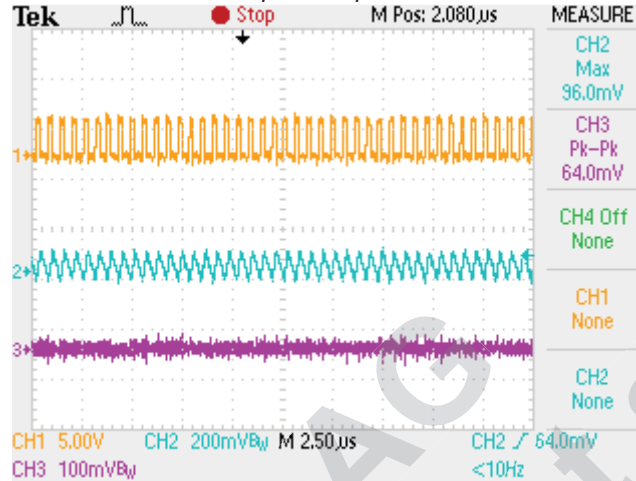

1: LXC1 voltage, 2: coil current (1mV=1mA) 3: output voltage

### High efficiency operation:

In this mode there is a minimum coil current necessary before switching off the PMOS. As result, fewer pulses at low output loads are necessary, and therefore the efficiency at low output load is increased. On the other hand the output voltage ripple increases, and the noisy pulse skip operation is on up to a higher output current.

Figure 23. DCDC buck with enabled current force / pulse skip mode

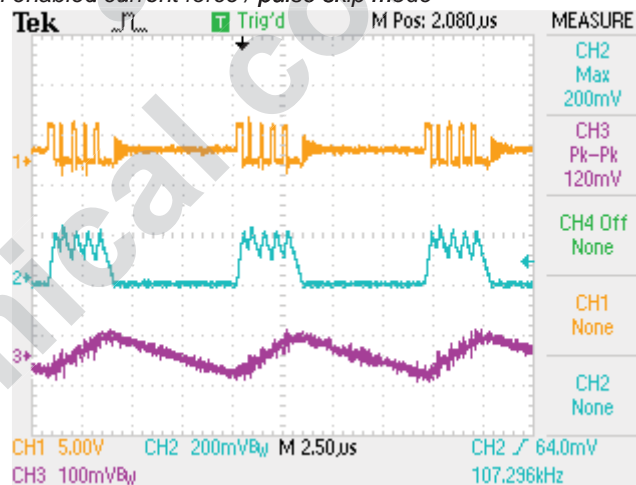

1: LXC1 voltage, 2: coil current (1mV=1mA) 3: output voltage

It's also possible to switch between these two modes dynamically during operation:

### 100% PMOS ON mode for low dropout regulation:

For low input to output voltage difference the DCDC converter can use 100% duty cycle for the PMOS transistor, which is than in LDO mode. This feature is enabled if the output voltage drops by more than 4%.

### 9.2.3 Parameter

BVDD=3.6,  $T_A=25^{\circ}\text{C}$ , unless otherwise mentioned

Table 22. DCDC Parameter

Symbol	Parameter	Condition	Min	Typ	Max	Unit
$V_{IN}$	Input voltage	BVDD	2.7		5.5	V
$V_{OUT}$	Regulated output voltage		0.65		3.4	V
$V_{OUT\_tol}$	Output voltage tolerance	minimum +/- 50mV	-3%		3%	mV
$I_{load}$	Maximum Load current			250		mA
$I_{LIMIT}$	Current limit			450		mA
$R_{PSW}$	P-Switch ON resistance	BVDD=3.0V		0.5	0.7	$\Omega$
$R_{NSW}$	N-Switch ON resistance	BVDD=3.0V		0.5	0.7	$\Omega$
$f_{sw}$	Switching frequency	depending on DCDC_Cntr settings		1/2		MHz
$f_{SWsc}$	Switching frequency	in shortcut case		0.6		MHz
$C_{out}$	Output capacitor	Ceramic, +/- 10% tolerance		10		$\mu\text{F}$
$L_x$	Inductor	+/- 10% tolerance	2.2		4.7	$\mu\text{H}$
$\eta_{eff}$	Efficiency	$I_{out}=100\text{mA}$ , $V_{out}=3.0\text{V}$		97		%
$I_{VDD}$	Current consumption	Operating current without load Low power mode current Shutdown current		220 100 0.1		$\mu\text{A}$
$t_{MIN\_ON}$	Minimum on time			80		ns
$t_{MIN\_OFF}$	Minimum off time			40		ns
$V_{LineReg}$	Line regulation	Static		2		mV
		Transient; Slope: $t_r=10\mu\text{s}$ , 100mV step, 200mA load		10		
$V_{LoadReg}$	Load regulation	Static		5		mV
		Transient; Slope: $t_r=10\mu\text{s}$ , 100mA step		50		

Figure 24. DCDC Step-down Performance Characteristics

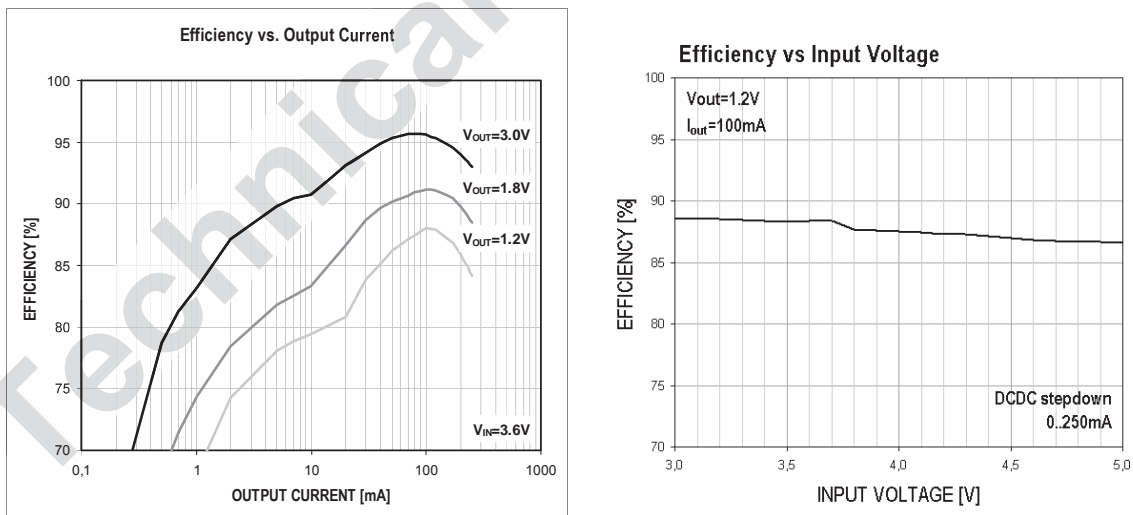

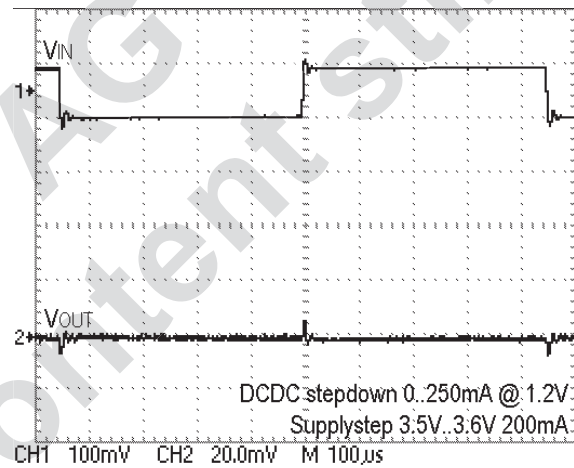
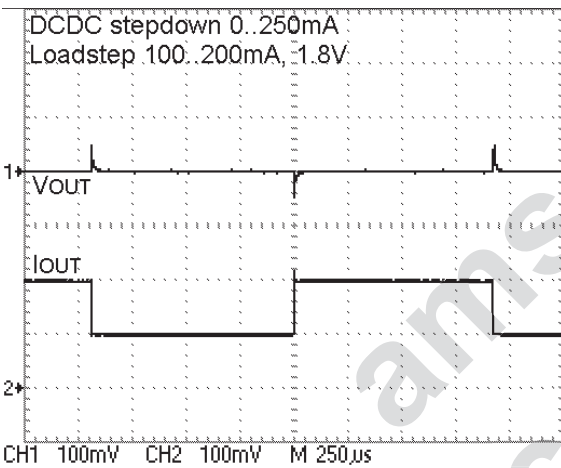
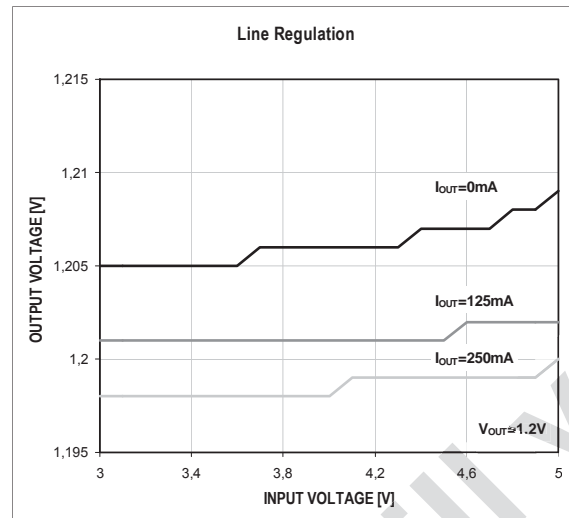
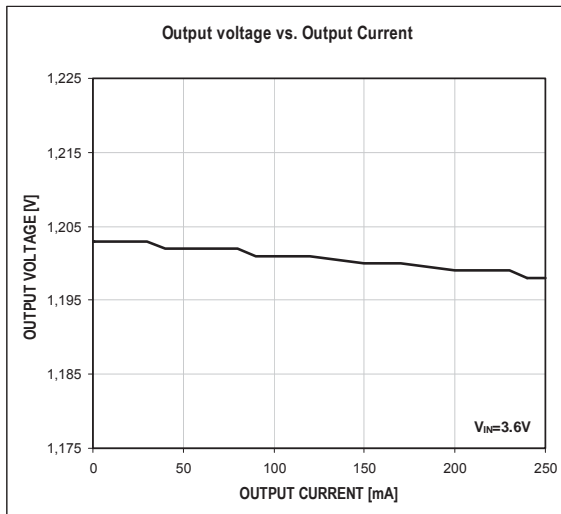

## 9.2.4 Register Description

Table 23. DCDC Buck Related Register

Name	Base	Offset	Description
CVDD1	2-wire serial	17h-1	CVDD1 (DCDC1) voltage settings
CVDD2	2-wire serial	17h-2	CVDD2 (DCDC2) voltage settings
Hibernation	2-wire serial	17h-6	Hibernation control
DCDC_Cntr	2-wire serial	17h-7	DCDC frequency and DVM settings
PMU_Enable	2-wire serial	1Ch	Enables writings to extended registers 17h-1 to 17h-7

## 9.3 15V Step-Up DCDC Converter

### 9.3.1 General

The integrated Step-Up DC/DC Converter is a high efficiency current-mode PWM regulator, providing an output voltage up to 15V. A constant switching-frequency results in a low noise on supply and output voltages.

It has two programmable high voltage current sinks (1.2 to 37.2mA) for driving e.g. white LEDs as back-light. It can drive also unbalanced strings due to the internal automatic feedback selection.

A voltage feedback mode allows generating constant supply voltages for e.g. OLEDs by using an external Zener diode. To bias the diode ISINK1 is sinking about 50uA in this voltage feedback mode.

An internal protection circuit will shut down the regulator if the voltage on SW15 exceeds 15V. No more external protection has to be used to avoid an exceeding of the operation conditions in a no load situation.

### 9.3.2 Dimming

The DCDC booster together with the current sinks has an adjustable automatic logarithmic dimming for a smooth ON/OFF transition. It is also possible to control the dimming with an external signal via a GPIO pin. PWGD, Q24M or Q32K pin can be selected as input for the external dimming signal.

### 9.3.3 Current Sink Only Mode

The current sinks are normally only working when the DCDC booster is switched on, but can also be activated separately. To do so reg. 1Bh-1 has to be set to 08h (select external dimming), and reg. 1Ah-4 has to be set to xxxx xx00b (no ext. dimming source selected).

Figure 25. DCDC15 Block Diagram

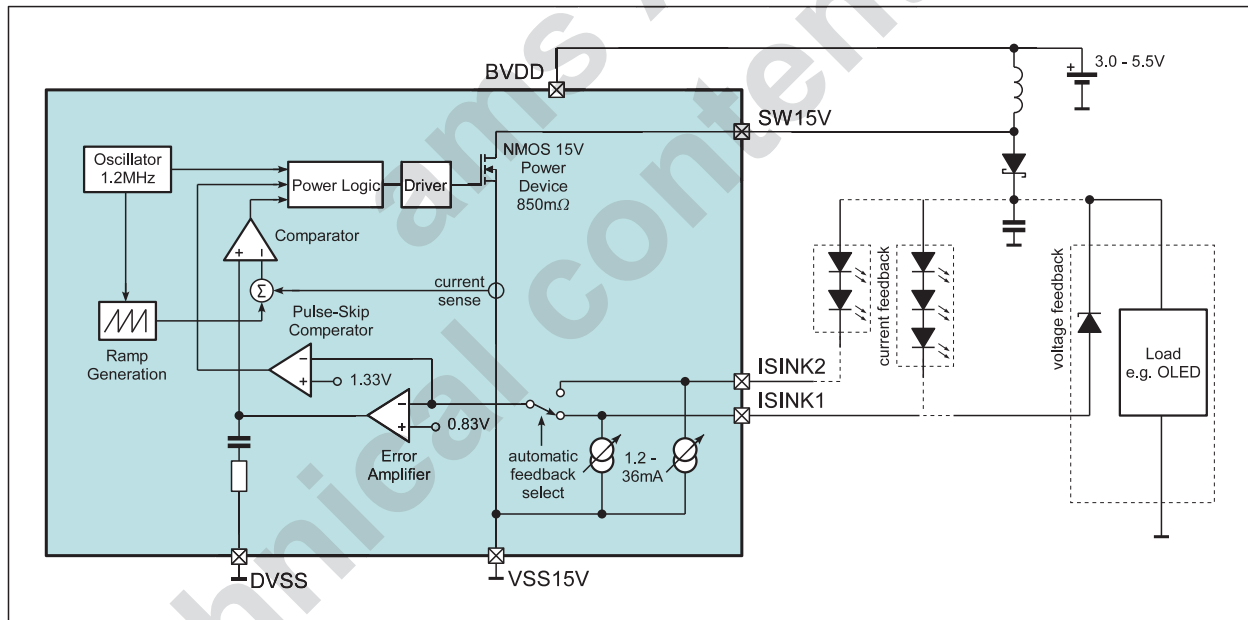

### 9.3.4 Parameter

BVDD=3.6V,  $T_A=25^{\circ}\text{C}$ , unless otherwise mentioned

Table 24. DCDC Parameter

Symbol	Parameter	Condition	Min	Typ	Max	Unit
V <sub>SW</sub>	High Voltage Pin	Pin SW15	0		15	V
I <sub>VDD</sub>	Quiescent Current	Pulse Skipping mode		140		μA
V <sub>FB</sub>	Feedback Voltage, Transient	Pin ISINK1 or ISINK2	0		5.5	V
V <sub>FB</sub>	Feedback Voltage, during Regulation	Pin ISINK1 or ISINK2		0.63		V
I <sub>SW_MAX</sub>	Current Limit	V15_ON = 1	350	510	750	mA
R <sub>SW</sub>	Switch Resistance	V15_ON = 0		0.85	1.54	Ω
I <sub>LOAD</sub>	Load Current	@ 15V output voltage	0		45	mA
I <sub>FB</sub>	Current into ISINK1 during voltage feedback mode			50		μA
V <sub>PULSESKIP</sub>	Pulse-skip Threshold	Voltage at pin ISINK1 or ISINK2, pulse skips are introduced when load current becomes too low		0.96		V
F <sub>IN</sub>	Fixed Switching Frequency		0.45	0.66	0.85	MHz
C <sub>OUT</sub>	Output Capacitor	Ceramic		1		μF
L (Inductor)	I <sub>LOAD</sub> > 20mA	Use inductors with small C <sub>PARASITIC</sub> (<100pF) for high efficiency	17	22	27	μH
	I <sub>LOAD</sub> < 20mA		8	10	27	
t <sub>MIN_ON</sub>	Minimum On-Time	Guaranteed per design	90		200	ns
MDC	Maximum Duty Cycle	Guaranteed per design	84	91	98	%

Figure 26. 15V Step-Up Performance Characteristics

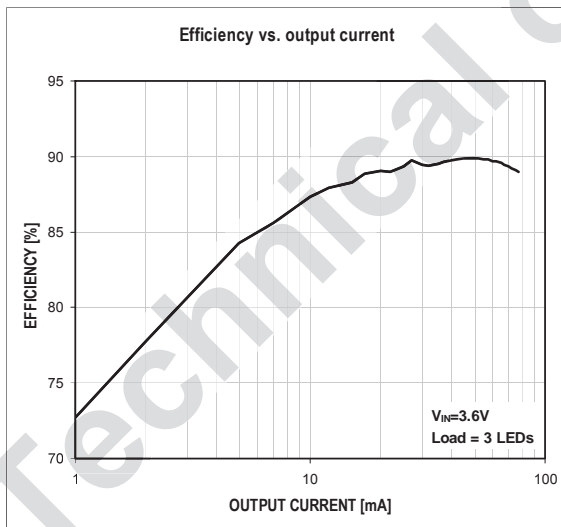

### 9.3.5 Register Description

Table 25. DCDC15 Related Register

Name	Base	Offset	Description
In_Cntr	2-wire serial	1Ah-4	Selection of external dimming input
DCDC15	2-wire serial	1Bh-1	DCDC15 on/off and dimming control
ISINK1	2-wire serial	1Bh-2	ISINK1 current settings
ISINK2	2-wire serial	1Bh-3	ISINK2 current settings
PMU_Enable	2-wire serial	1Ch	Enables writings to extended registers 1Ah1, 1Bh-1 to 1Bh-3

## 9.4 Charger

### 9.4.1 General

This block can be used to charge a 4V Li-Ion accumulator. It supports constant current and constant voltage charging modes with adjustable charging currents (55 to 460mA) and maximum charging voltage (3.9 to 4.25V).

An internal protection circuit will limit the charging current when a CHGIN voltage drop is detected.

For the end of charge current four levels can be selected while the battery temperature shutdown has two temperature levels to choose from.

The current battery voltage as well as the actual charging current can be measured with the general purpose ADC.

Figure 27. Charger Block Diagram

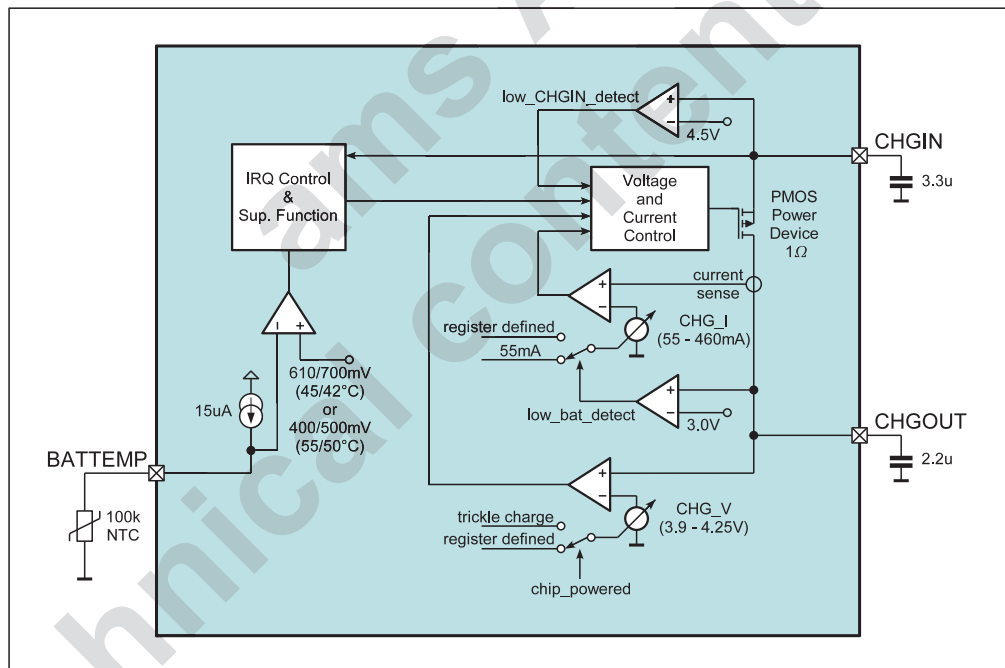
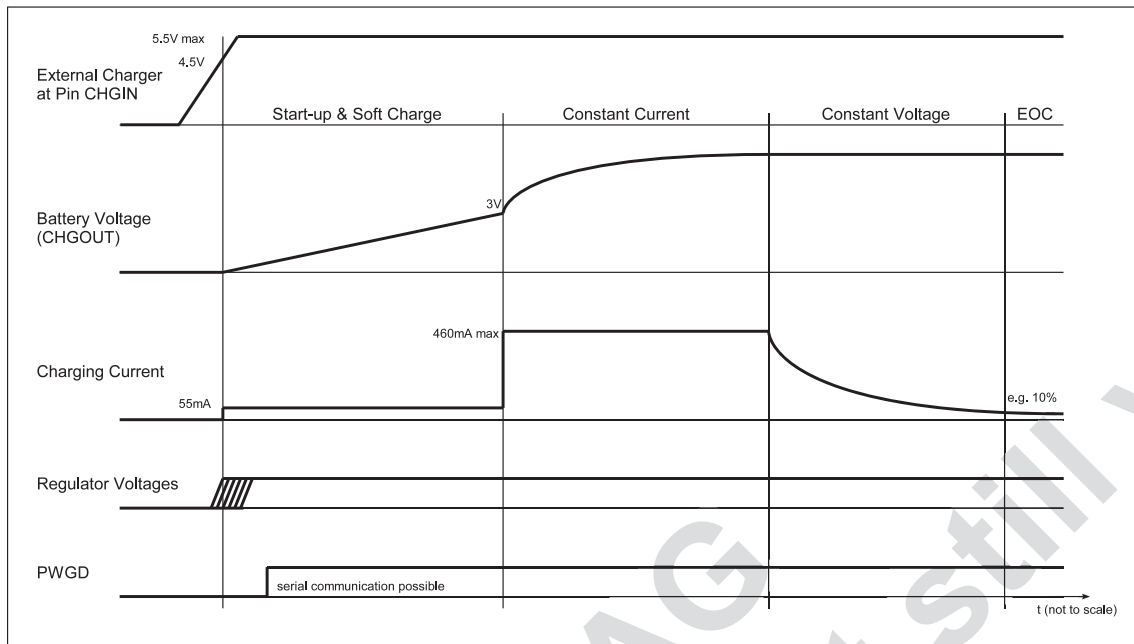

Figure 28. Charger States



### 9.4.2 Soft Charge

If the battery and therefore CHGOUT is below 3V the charger is working in a fixed soft charge mode with the smallest possible charging current of 55mA and 3.9V charger end voltage. After reaching the 3V level the charger switches to the register defined mode and sets the programmed charging current and voltage.

### 9.4.3 End of Charge Detection

For the EOC level 4 presets can be selected. This makes it possible to monitor the charging progress also during constant voltage mode. If the EOC level is reached an interrupt can be generated, but it is also possible to poll the charger status bits at any time.

### 9.4.4 Temperature Supervision

This charger block also features a 15uA supply for an external 100k NTC resistor to measure the battery temperature while charging. If the temperature is too high, an interrupt can be generated. If the battery temperature drops the charger will start charging again. The levels for switching off/on the charger (45/42°C or 55/50°C) can be selected via register settings.

If the NTC resistor does not have 100kΩ its value can be corrected with a resistor in series or in parallel.

### 9.4.5 Parameter

AVDD27=2.7,  $T_A = 25^\circ\text{C}$ , unless otherwise mentioned

Table 26. Charger Parameter

Symbol	Parameter	Condition	Min	Typ	Max	Unit
I <sub>CHG</sub> (0-7)	Charging Current	BVDD > 2.7V, I <sub>CHG</sub> > 60mA	I <sub>NOM</sub> -8%	I <sub>NOM</sub>	I <sub>NOM</sub> +8%	mA
V <sub>CHG</sub> (0-7)	Charging Voltage	BVDD > 2.7V, end of charge is true	V <sub>NOM</sub> -50mV	V <sub>NOM</sub>	V <sub>NOM</sub> +30mV	V
V <sub>ON_ABS</sub>	Charger On Voltage IRQ	CHGOUT > 3V		3.1	4.0	V
V <sub>ON_REL</sub>	Charger On Voltage IRQ	CHGIN-CHGOUT		170	240	mV
V <sub>OFF_REL</sub>	Charger Off Voltage IRQ	CHGIN-CHGOUT	40	77		mV

Table 26. Charger Parameter

Symbol	Parameter	Condition	Min	Typ	Max	Unit
V <sub>BATEMP_ON</sub>	Battery Temp. high level (45 or 55°C)	BVDD >3V		610 or 400		mV
V <sub>BATEMP_OFF</sub>	Battery Temp. low level (42 or 50°C)	BVDD >3V		700 or 500		mV
I <sub>CHG_OFF</sub>	End Of Charge current level	BVDD >3V	5% I <sub>NOM</sub>	10% 30% 50% 70% I <sub>NOM</sub>	15% I <sub>NOM</sub>	mA
I <sub>REV_OFF</sub>	Reverse current shut down	BVDD = 5V, CHGIN open		<1		uA

### 9.4.6 Register Description

Table 27. Charger Related Register

Name	Base	Offset	Description
CHGVBUS1	2-wire serial	19h-1h	Charger voltage, current and temp. supervision control
CHGVBUS2	2-wire serial	19h-2h	Charger temperature and EOC level settings
PMU_Enable	2-wire serial	1Ch	Enables writings to extended registers 19h-1 to 19h-2
IRQENRD_2	2-wire serial	25h	Enable/disable EOC and battery over-temperature interrupt Read out charger status
IRQENRD_4	2-wire serial	27h	Set CHGIN debounce time
ADC10_0	2-wire serial	2Eh	ADC source selection, ADC result<9:8>
ADC10_1	2-wire serial	2Fh	ADC result <7:0>

## 9.5 Battery Switch

### 9.5.1 General

An integrated battery separation during charging. In normal battery operation the switch is closed. With an ideal diode function a smooth transition between the different modes are guaranteed.

Figure 29. Battery Switch Modes

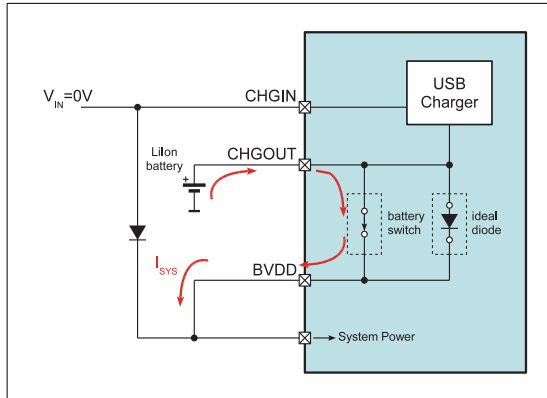

In normal operation, when the charger is not connected, all the system current comes out of the battery

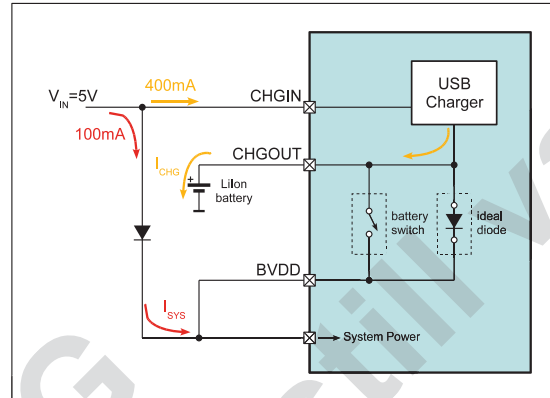

During charging the battery switch opens and the system is supplied direct from the charger input.

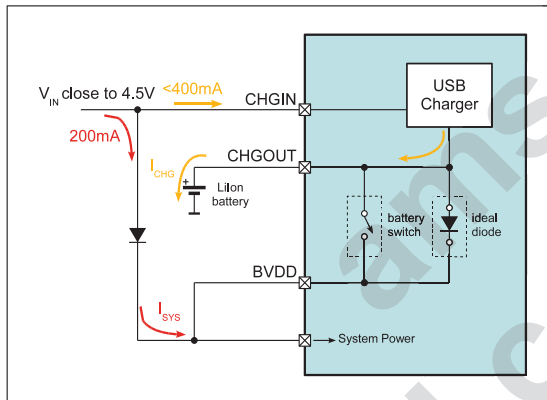

If the system current (red) plus the charger current (yellow) is higher than the maximum available current from USB or wall adapter,  $V_{IN}$  will drop.

If it comes close to 4.5V the charger will automatically reduce the charging current, which will bring up  $V_{IN}$  to its nominal voltage again.

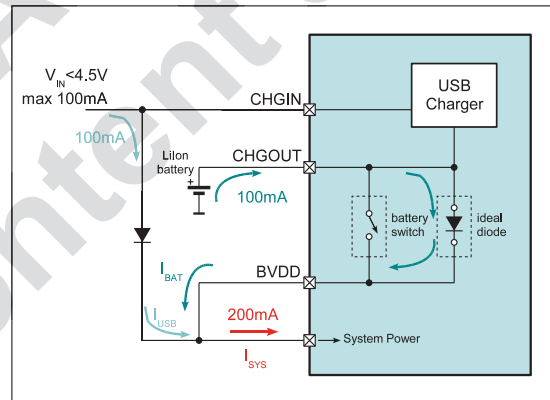

If the system current (red) is higher than the max. available current from e.g. USB, then the additional needed current will be provided from the battery.

To ensure a smooth transition an ideal diode will provide the current till the battery switch closes.

This ideal diode function will also ensure a smooth switchback to battery operation, when the USB or wall adapter connector is plugged out.

## 10 Detailed Description - SYSTEM Functions

### 10.1 SYSTEM

#### 10.1.1 General

The system block handles the power up, power down and regulator voltage settings of the AFE.

The PWGD and XRES outputs can be configured to operate in push/pull (2 different driver strengths) open-drain mode or to be tri-state. For a more detailed description of the GPIO functionality of these pins please refer to chapter [GPIO Pins](#) on page 50.

#### 10.1.2 Power Up/Down Conditions

The chip powers up when one of the following condition is true:

Table 28. Power UP Conditions

#	Source	Description
1	PWRUP PwUp	ON_KEY High Level at PRWUP pin of $\geq 1/3$ BVDD
2	CHGIN PwUp	Charger Plug-In ... High level at CHGIN pin of $\geq 4.0V$
3	VBUS PwUp	USB Plug-In .... High level at VBUS pin of $\geq 4.5V$
4	WAKEUP PwUp	Wake-Up Timer power-up on RTC clock
4	MCLK PwUp	ON_KEY High Level at MCLK pin of $\geq 1/3$ BVDD

The chip automatically shuts off if one of the following conditions arises:

Table 29. Power DOWN Conditions

#	Source	Description
1	SERIF MAJOR PwDn	<b>Power-Down</b> by SERIF writing 0h to register 20h This Power-Down clears wake-up as well.
2	Emergency PwDn	<b>Power-Down</b> if PWRUP pin is HIGH for 10sec. This time can be reduced to 5sec with bit 7 in register 21h.
3	Wake-Up PwDn	write 4h to reg. 1Ch and 0h to reg. 1Ah ... disable heartbeat source Write 3 times to reg.22h to define wake-up time; <b>Power-Down</b> by heartbeat without source by writing 9h to reg. 20h
4	Heartbeat PwDn	write 4h to reg. 1Ch and 4h/8h or Ch to reg. 1Ah ... select HBT source write 9h to reg. 20h ... enable heartbeat with source <b>Power-Down</b> if no edge on the selected HBT source is seen for 500ms.
5	SERIF Watch-Dog PwDn	write 3h to reg. 20h ... enable SERIF watch-dog <b>Power-Down</b> if no SERIF read is seen for 500ms.
6	Junction-Temp PwDn	<b>Power-Down</b> if junction temperature rises up to 140degC. This threshold can be lowered with bits <4:0> in reg 21h. This supervisor can be disabled with bit 2 in reg. 20h.
7	BVDD LOW PwDn	<b>Power-Down</b> if AVDD27 LDO has 10% under-voltage for more than 680us. This supervisor can get disabled with bit 6 in reg. 21h.
8	PVDD1 LOW PwDn	<b>Power-Down</b> if enabled with bit 1 in reg. 23h and PVDD1 LDO has 10% under-voltage for more than 680us.
9	PVDD2 LOW PwDn	<b>Power-Down</b> if enabled with bit 3 in reg. 23h and PVDD2 LDO has 10% under-voltage for more than 680us.
10	CVDD1 LOW PwDn	<b>Power-Down</b> if enabled with bit 7 in reg. 23h and CVDD1 DCDC has 10% under-voltage for more than 680us.
11	CVDD2 LOW PwDn	<b>Power-Down</b> if enabled with bit 1 in reg. 24h and CVDD2 DCDC has 10% under-voltage for more than 680us.

### 10.1.3 Start-up Sequence

The AFE offers different power-up sequences. While VPRG1 and VPRG2 pins are defining the regulator voltages VPRG3 is setting the sequence of powering on the regulators during the start-up. These pins detect 5 logical input states which shall come from an external resistor divider network.

At first, LDO2 (AVDD27) and LDO1 (AVDD17) are powered up. This cannot be influenced with the selection of specific sequences below. LDO2 is necessary for the internal supply of the AFE, LDO1 could be turned off later if no audio functionality is needed.

After power-up sequence all voltage settings and power on/off conditions of the described regulators can be programmed via the serial interface

Table 30. Start-Up Sequence

	CVDD1	CVDD2	PVDD1	PVDD2
<b>VPRG1 (core)</b>				
vdd	0.8V			
150k PU <sup>1</sup>	1.5V			
open	1.2V			
150k PD <sup>2</sup>				
vss	1.0V			
<b>VPRG2 (peri)</b>				
vdd		2.5V	3.3V	3.3V
150k PU		2.8V	1.8V	3.3V
open		1.8V	3.3V	3.3V
150k PD				
vss		3.3V	3.3V	3.3V
<b>VPRG3 (sequence)</b>				
vdd	1 <sup>st</sup>	2 <sup>nd</sup>	3 <sup>rd</sup>	off
150k PU	1 <sup>st</sup>	2 <sup>nd</sup>	3 <sup>rd</sup>	3 <sup>rd</sup>
open	3 <sup>rd</sup>	2 <sup>nd</sup>	1 <sup>st</sup>	1 <sup>st</sup>
150k PD				
vss	3 <sup>rd</sup>	2 <sup>nd</sup>	1 <sup>st</sup>	off

1. pull ups (PU) must be connected to AVDD27
2. pull downs (PD) shall be connected to DVSS

### 10.1.4 XRES delay with PWGD pin

With using an external capacitor on PWGD, the XRES signal can be delayed. This delay can be calculated with the 10uA pull-up current and a comparator threshold of ~1V. Using a 100nF capacitance will give a delay of 10ms.

### 10.1.5 Register Description

Table 31. System Related Register

Name	Base	Offset	Description
Out_Cntr1	2-wire serial	1A-1h	Control of PWGD and XRES signal and drive
In_Cntr	2-wire serial	1A-4h	Selection of HBT input pin
PMU_Enable	2-wire serial	1Ch	Enables writings to extended registers 1Ah-1 and 1Ah-5
SYSTEM	2-wire serial	20h	Watchdog and Over-temperature control, Power down enable
SUPERVISOR	2-wire serial	21h	Set emergency shutdown time
IRQENRD_0	2-wire serial	23h	Enable/disable PMU interrupts
IRQENRD_1	2-wire serial	24h	Enable/disable wake-up, voice and PMU interrupts
IRQENRD_2	2-wire serial	25h	Enable/disable charger, USB and supervisor interrupts
IRQENRD_3	2-wire serial	26h	Enable/disable junction temperature interrupt

## 10.2 Hibernation

### 10.2.1 General

Hibernation allows shutting down a part or the complete system. Hibernation can be terminated by every possible interrupt of the AFE. E.g. one can use the RTC for a time triggered wake-up. The interrupt has to be enabled before going to hibernation.:

Table 32. Hibernation

State	Description
Enter	<p>To enter hibernation mode the following settings have to be done:</p> <ul style="list-style-type: none"> <li>- Enable just these IRQ sources which should lead to leave hibernation mode.</li> <li>- Make sure that IRQ is inactive (IRQ flags get cleared by Reg0x23-27 readings).</li> <li>- Define which regulators should be kept powered and enter hibernation by writing to Reg 1Ch_0x06 + Reg 17h_0xXX</li> </ul> <p>Note that hibernation will shutdown regulators which are not in the keep list of the mentioned Reg 17h writing and which are powered by the selected power-up sequence. (e.g. PVDD2 will not go hibernation with VPRG3 is vss or vdd)</p>
Hibernation	<p>VDD27 chip supply is kept ON</p> <p>All other regulators are switched OFF dependent on the KEEP-Bits</p> <p>XRES goes active and PWGD goes inactive.</p>
Leave	<p>The chip will come out of Hibernation with IRQ activation.</p> <p>Start-Up sequence is provided defined by the VPRG state latched on the previous Start-Up. (VPRG state does not get latched again by leaving hibernation)</p>

### 10.2.2 Register Description

Table 33. Hibernation Related Register

Name	Base	Offset	Description
Hibernation	2-wire serial	17h-6	Hibernation control
PMU_Enable	2-wire serial	1Ch	Enables writings to extended register 17h-6

## 10.3 Supervisor

### 10.3.1 General

This supervisor function can be used for automatic detection of BVDD brown out or junction over-temperature condition.

### 10.3.2 BVDD Supervision

The BVDD supervision interrupt level is set to 175mV above regulator output AVDD27. When BVDD reaches this level an interrupt can be generated.

If AVDD27 reaches the “programmed level of AVDD27” -10% for more than 680us, the AFE shuts down automatically, if the shutdown is not disabled.

### 10.3.3 Junction Temperature Supervision

The temperature supervision level can also be set by 5 bits (120 to –15°C). If the temperature reaches this level, an interrupt can be generated. The over-temperature shutdown level is always 20°C higher.

### 10.3.4 Power Rail Monitoring

The 4 main regulators as well as the DCDC15 booster and the system supply AVDD27 have an extra monitor which observes the output voltage of the regulators. This power rail monitors are independent from the 10bit ADC. To activate these please see related registers. For a shut down the voltage of the regulator has to be 10% or more below the programmed value for more than 680us.

### 10.3.5 Register Description

Table 34. Supervisor Related Register

Name	Base	Offset	Description
SUPERVISOR	2-wire serial	21h	Low battery shutdown disable and junction temperature supervision threshold levels
IRQENRD_0	2-wire serial	23h	Enable/disable PVDD/CVDD monitoring interrupt and shutdown
IRQENRD_1	2-wire serial	24h	Enable/disable PVDD/CVDD monitoring interrupt and shutdown
IRQENRD_2	2-wire serial	25h	Enable/disable battery brown out interrupt
IRQENRD_3	2-wire serial	26h	Enable/disable junction temperature interrupt
IRQENRD_4	2-wire serial	27h	Enable/disable AVDD27 and DCDC15 monitoring interrupt

## 10.4 Interrupt Generation

### 10.4.1 General

All interrupt sources can get enabled or disabled by corresponding bits in the 5 IRQ-bytes. By default no interrupt source is enabled.

The XIRQ output can be configured to operate in push/pull (2 different driver strengths), open-drain mode or to be tri-state. The signal polarity can be defined as active-low or active-high. Default state is open-drain active-low. For a more detailed description of the GPIO functionality of this pin please refer to chapter [GPIO Pins on page 50](#).

### 10.4.2 IRQ Source Interpretation

There are 3 different modules to process interrupt sources:

#### LEVEL

The IRQ output is kept active as long as the interrupt source is present and this IRQ-Bit is enabled

#### EDGE

The IRQ gets active with a high going edge of this source. The IRQ stays active until the corresponding IRQ-Register gets read.

## STATUS CHANGE

The IRQ gets active when the source-state changes. The change bit and the status can be read to notice which interrupt was the source. The IRQ stays active until the corresponding interrupt register gets read.

### 10.4.3 De-bouncer

There is a de-bounce function implemented for USB and CHARGER. Since these 2 signals can be unstable for the phase of plug-in or unplug, a de-bounce time of 512ms/256ms/128ms/8ms can be selected by 2 bits in the IRQ\_ENRD\_4 register (27h).

### 10.4.4 Interrupt Sources

26 IRQ events will activate the XIRQ pin:

- Headphone connected
- Headphone over-current
- Microphone connected
- Microphone remote control
- Voice activation threshold reached
- RTC sec/min elapsed
- 10bit ADC end of conversion
- I<sup>2</sup>S changed (active/inactive)
- USB changed (connect/disconnect)
- Charger changed (end of charge or connect/disconnect)
- Battery temperature high (at 45°C or 55°C with 100kΩ NTC)
- Junction temperature high
- RTC watchdog (e.g. after battery was changed)
- Battery low (Brown-out voltage reached)
- Wake-up from hibernation
- Power-up key (pin PWRUP) pressed
- Power rail monitor: over-voltage PVDD1, PVDD2, CVDD1, CVDD2, DCDC15
- Power rail monitor: under-voltage PVDD1, PVDD2, CVDD1, CVDD2, AVDD27

### 10.4.5 Register Description

Table 35. Interrupt Related Register

Name	Base	Offset	Description
Out_Cntr3	2-wire serial	1A-3h	Control of XIRQ signal, polarity and drive
PMU_Enable	2-wire serial	1Ch	Enables writings to extended register 1Ah-3 and 1Ah-5
IRQENRD_0	2-wire serial	23h	Enable/disable PMU interrupts
IRQENRD_1	2-wire serial	24h	Enable/disable wake-up, voice and PMU interrupts
IRQENRD_2	2-wire serial	25h	Enable/disable charger, USB and supervisor interrupts
IRQENRD_3	2-wire serial	26h	Enable/disable junction temperature, headphone, microphone and I <sup>2</sup> S interrupt
IRQENRD_4	2-wire serial	27h	Enable/disable PMU, RTC, ADC10 and microphone interrupt, set VBUS and CHGIN debounce time

## 10.5 Real Time Clock

### 10.5.1 General

The real time clock block is an independent block, which is still working even when the chip is shut down. The only condition for this operation is that BVDDR has a voltage of above 1.0V. The block uses a standard 32kHz crystal that is connected to a low power oscillator. The total power consumption is typ. 650nA. (Q32K clock buffer not operating)

An internal supply switch will supply the RTC as long as possible from the Li-Ion battery and only switch to BVDDR if the main battery is empty or has been removed.

The RTC seconds counter is 32bit wide and can be programmed via the 2-wire serial interface. The RTC can deliver a second or minute interrupt.

Another 23bit wide counter allows auto wake-up (max. after 96 days). This counter is internally connected to the power-up and hibernation control block.

The RTC voltage regulator (RVDD) further supplies a 128bit SRAM. It can be used to store settings or data before shutdown.

The Q32K output can be configured to operate in push/pull (3 different driver strengths) or to be tri-state. For a more detailed description of the GPIO functionality of this pin please refer to chapter [GPIO Pins on page 50](#).

### 10.5.2 Clock Adjustment

The RTC clock is adjustable in steps of 7.6ppm which allows the use of inexpensive 32kHz crystals. The nominal frequency shall be 32.768Hz. This frequency is divided down to 0.25Hz:  
 $f = 32.768 / (4 * 32 * 1024)$

At the input of this divider one can add corrective counts, which allow to correct an inaccurate crystal in a range from – 64 counts (=-488ppm) to +63 counts (="+480ppm):

$$f_{corrected} = f_{crystal} / [(4 * 32 * 1024) - 64 + RTC\_TBC]$$

### 10.5.3 Register Description

Table 36. RTC Related Register

Name	Base	Offset	Description
RAM & WakeUp	2-wire serial	19h	RTC wake-up settings and SDRAM access
Out_Cntr2	2-wire serial	1A-2h	Control of Q32K signal and drive
PMU_Enable	2-wire serial	1Ch	Enables writings to extended register 1Ah-2
IRQENRD_2	2-wire serial	25h	Interrupt settings for RVDD under-voltage detection
IRQENRD_4	2-wire serial	27h	Interrupt settings for getting a second or minute interrupt
RTC_Cntr	2-wire serial	28h	RTC oscillator and counter enable, free usable bits
RTC_Time	2-wire serial	29h	RTC interrupt and time correction settings
RTC_0 to RTC_3	2-wire serial	2Ah to 2Dh	RTC time-base seconds registers

## 10.6 10-Bit ADC

### 10.6.1 General

This general purpose ADC can be used for measuring several voltages and currents to perform functions like battery monitor, temperature supervision, button press detection, etc.

### 10.6.2 Input Sources

Table 37. ADC10 Input Sources

#	Source	Range	LSB	Description
0	BVDD	5.120V	5mV	check main system input voltage
1	BVDDR	5.120V	5mV	check RTC backup battery voltage
2	CHGIN	5.120V	5mV	check charger input voltage
3	CHGOUT	5.120V	5mV	check battery voltage of 4V Li-Ion accumulator
4	VBUS	5.120V	5mV	check USB input voltage
5		5.120V	5mV	Source defined by DC_TEST in register 18h
6	BatTemp	2.048V	2mV	check battery charging temperature
7				reserved
8	MICS	2.048V	2mV	check voltage on MICS for remote control or external voltage measurement
9				reserved
A	I_MICS	1.024mA typ.	2uA	check current of MICS for remote control detection
B				reserved
C	VBE_1uA	1.024	1mV	measuring basis-emitter voltage of temperature sense transistor; $T_j = (674 - \text{ADC10}\langle 9:0 \rangle) / 2$
D	VBE_2uA	1.024	1mV	measuring basis-emitter voltage of temperature sense transistor; $T_j = (694 - \text{ADC10}\langle 9:0 \rangle) / 2$
E	I_CHGact	1.024V	1mV	check active charger current
F	I_CHGref	1.024V	1mV	check reference charger current

### 10.6.3 Parameter

AVDD27=2.7, T<sub>A</sub>= 25°C, unless otherwise mentioned

Table 38. ADC10 Parameter

Symbol	Parameter	Condition	Min	Typ	Max	Unit
ADC <sub>FS</sub>	ADC Full Scale Range			2.16		V
T <sub>CON</sub>	Conversion Time		-	34	50	μs
I <sub>MICFS</sub>	I_MICS Full Scale Range		0.7	1.0	1.4	mA

## 10.6.4 Register Description

Table 39. ADC10 Related Register

Name	Base	Offset	Description
PMU_Enable	2-wire serial	1Ch	Extended ADC source selection
IRQENRD_4	2-wire serial	27h	Interrupt settings for end of conversion interrupt
ADC10_0	2-wire serial	2Eh	ADC source selection, ADC result<9:8>
ADC10_1	2 wire serial	2Fh	ADC result <7:0>

## 10.7 GPIO Pins

### 10.7.1 General

PWGD, XRES, Q24M, Q32K, SDO, XIRQ are so called GPIO (general purpose inputs/outputs) as they can feature auxiliary functionality.

If the main pin function is not needed all pins can provide internal clocks or can drive a static HIGH or LOW. Four different clock lines (CLKINT1, CLKINT2, CLK24M, CLK32K) can be selected. Each of these clock lines can drive different frequencies which can be set by register options. In addition some pins can provide a PWM signal. The duty cycle of the PWM output can also be set in the registers.

PWGD, XRES and XIRQ can be configured also as open drain outputs. For all pins the driver strength of the push/pull output mode can be selected.

PWGD, Q24M, Q32K can also be used as inputs for a heartbeat signal or an external dimming signal for the DCDC15 booster.

### 10.7.2 Internal Source Signals

#### CLKINT1 Signal

This is an internal signal line which can drive pre defined frequencies of 125Hz, 1kHz, 667kHz or 2MHz. This signal line can be selected as source for the XRES, Q24M, Q32K, XIRQ and SDO GPIO output pins.

#### CLKINT2 Signal

This is an internal signal line which can drive the PLL clock, the clock for the logarithmic dimming of DCDC15 or can be set to static HIGH/LOW. This signal line can be selected as source for the PWGD, Q24M, Q32K and XIRQ output pins.

#### CLK24M Signal

This is an internal signal line which is driving the 12-24MHz oscillator output clock per default, but can be set to drive this clock divided by 2 or 4. The forth option is to deactivate the 12-24MHz oscillator.

#### CLK32K Signal

This is an internal signal line which is driving the 32kHz oscillator output clock per default, but can be set to drive also a 1Hz signal as well as a static HIGH/LOW.

#### PWM Signal

The duty cycle of the PWM signal can be set in 128 steps plus an option to invert the signal. It can be used as source for all GPIO outputs other than XIRQ.

### 10.7.3 Pin Functions

#### PWGD Pin

Can drive CLK24M, CLKINT2 or the PWM signal as auxiliary function. The output can be configured to operate in push/pull (2 different driver strength) open-drain mode or to be tri-state. It can be used as an input for a heartbeat, external dimming signal or as additional source for the 10-bit general purpose ADC.

Using a capacitor on this pin will delay the XRES signal. Please refer to chapter [XRES delay with PWGD pin on page 44](#). When using the pin as an ADC input the voltage to be measured has to be higher than 1V, the XRES delay functionality is then no longer available.

### XRES Pin

Can drive CLK32K, CLKINT1 or the PWM signal as auxiliary function. The output can be configured to operate in push/pull (2 different driver strengths) open-drain mode or to be tri-state.

The XRES signal can be delayed by using a capacitor on PWGD pin. Please refer to chapter [XRES delay with PWGD pin on page 44](#).

### Q24M Pin

Can drive CLKINT1, CLKINT2 or the PWM signal as auxiliary function. The output can be configured to operate in push/pull (3 different driver strengths) or to be tri-state. It can be used as an input for a heartbeat or external dimming signal.

### Q32K Pin

Can drive CLKINT1, CLKINT2 or the PWM signal as auxiliary function. The output can be configured to operate in push/pull (3 different driver strengths) or to be tri-state. It can be used as an input for a heartbeat or external dimming signal.

### XIRQ Pin

Can drive CLKINT1, CLKINT2 signal as auxiliary function. The output can be configured to operate in push/pull (2 different driver strengths) open-drain mode or to be tri-state. The interrupt signal polarity can be defined as active-low or active-high.

### SDO Pin

Can drive CLK24M, CLKINT1 or the PWM signal as auxiliary function. The output can be configured to operate in push/pull (3 different driver strengths) or to be tri-state.

## 10.7.4 Register Description

Table 40. GPIO Related Register

Name	Base	Offset	Description
<a href="#">Out_Cntr1</a>	2-wire serial	1A-1h	Control of PWGD and XRES signal and drive
<a href="#">Out_Cntr2</a>	2-wire serial	1A-2h	Control of Q32K signal and drive
<a href="#">Out_Cntr3</a>	2-wire serial	1A-3h	Control of XIRQ signal, polarity and drive
<a href="#">In_Cntr</a>	2-wire serial	1A-4h	Selection of HBT and DCDC 15 dimming input pin
<a href="#">Clk_Cntr</a>	2-wire serial	1A-5h	Selection of clock source or drive level for GPIO pins
<a href="#">PWM_Cntr</a>	2-wire serial	1A-6h	PWM duty cycle and polarity settings
<a href="#">PMU_Enable</a>	2-wire serial	1Ch	Enables writings to extended registers 1Ah-1 to 1Ah-6

## 10.8 12-24MHz Oscillator

### 10.8.1 General

This oscillator can be used to generate a system clock for e.g. a microprocessor if needed. It is not needed for any other AFE function. As the oscillator is default ON, it has to be disabled if not needed.

### 10.8.2 Register Description

Table 41. 12-24MHz Oscillator Related Register

Name	Base	Offset	Description
<a href="#">Clk_Cntr</a>	2-wire serial	1A-5h	Enable/disable oscillator and clock divider settings
<a href="#">PMU_Enable</a>	2-wire serial	1Ch	Enables writings to extended registers A1Ah-5

## 10.9 Unique ID Code (64 bit OTP ROM)

### 10.9.1 General

This fuse array is used to store a unique identification number, which can be used for DRM issues. The number is generated and programmed during the production process.

### 10.9.2 Register Description

Table 42. UID Related Register

Name	Base	Offset	Description
UID_0 to UID_7	2-wire serial	38h to 3Fh	Unique ID register 0 to 7

## 11 Register Definition

Table 43. I2C Register Overview

Addr	Name	b7	b6	b5	b4	b3	b2	b1	b0
<b>Audio Registers</b>									
00h	reserved								
01h	reserved								
02h	OUT_R	LOUT 0: HP; 1: LOUT	MUX_C<1:0> 0: SUM; 1: DAC; 2: LIN1(2); 3: MIC		OUTR_VOL<4:0> Gain from MUX_C to HPR/LOUTR = -40.5dB...+6dB				
03h	OUT_L	MUTE_K_ON	STAGE_ON	HPDET_ON	OUTL_VOL<4:0> Gain from MUX_C to HPL/LOUTL = -40.5dB...+6dB				
04h	reserved								
05h	reserved								
06h	MIC_R	MIC_MODE 0: Mono/Diff 1: SingleEnd	PRE_GAIN<1:0> 0: 30dB; 1: 36dB; 2: 42dB; 3: reserved		MICR_VOL<4:0> Gain from MicAmp (N4) to Mixer (N12) = -40.5dB...+6dB				
07h	MIC_L	MSUP_OFF	MUTE_D_ON	-	MICL_VOL<4:0> Gain from MicAmp (N4) to Mixer (N13) = -40.5dB...+6dB				
08h	reserved								
09h	reserved								
0Ah	LINE_IN_R	LI_HIQ 0: LowPwr 1: HiQuality	MUX_E 0: LIN1 1: LIN2	MUTE_B_OFF	LIR_VOL<4:0> Gain from MUX_E (N27) to Mixer (N10) = -40.5dB...+6dB				
0Bh	LINE_IN_L	LO_DISCHG_FF	LI_MODE 0: stereo 1: mono	MUTE_G_OFF	LIL_VOL<4:0> Gain from MUX_E (N28) to Mixer (N17) = -40.5dB...+6dB				
0Ch	reserved								
0Dh	reserved								
0Eh	DAC_R	-	-	-	DAR_VOL<4:0> Gain from DAC (N19) to Mixer (N23) = -40.5dB...+6dB				
0Fh	DAC_L	-	-	MUTE_H_OFF	DAL_VOL<4:0> Gain from DAC (N22) to Mixer (N26) = -40.5dB...+6dB				
10h	ADC_R	MUX_A<1:0> 0: MIC; 1: LIN1; 2: LIN2; 3: SUM		-	ADR_VOL<4:0> Gain from MUX_A to ADC/Mixer (N9) = -34.5dB...+12dB				
11h	ADC_L	ADC_MODE<1:0> 0: Fdac/2; 1: Fdac/4; 2,3: Fdac/1		MUTE_A_OFF	ADL_VOL<4:0> Gain from MUX_A to ADC/Mixer (N18) = -34.5dB...+12dB				

Table 43. I2C Register Overview

Addr	Name	b7	b6	b5	b4	b3	b2	b1	b0
12h	DAC_IF	I2S_DIRECT	I2S_LOOP	I2S_ATTEN 0: NoAtten 1: AttenON	SDI_ATTEN<4:0> Attenuation of I2S input data = -48dB...-1.5dB				
13h	reserved								
14h	AudioSet1	ADC_ON	DAC_ON	DAC_GST_ON	-	LIN_ON	-	MIC_ON	
15h	AudioSet2	BIAS_OFF	SUM_OFF	SUM_AGC_OF F	SUM_HP_HIQ	GAIN_STEP<1:0> 0: 2ms; 1: 4ms; 2: 8ms; 3: no control	VMICS<1:0> 0: VDD17*20/17, 1: VDD17*20/22 2: VDD17*20/27, 3: VDD17*20/32		
16h	AudioSet3	-	MICMIX_OFF	-	ADCMIX_ON	LINMIX_OFF	HP_FASTSTAR T	HP_BIAS 0: *1 1: *1.5	HPCM_ON
<b>PMU Register</b>									
17h-1	CVDD1	PROG_CVDD1	VSEL_CVDD1>6:0> 0... OFF 0x01 - 0x40: 0.6V + VSEL * 12.5mV -> (0.6125V - 1.400V) 0x41 - 0x70: 1.4V + (VSEL-0x40) * 25mV -> (1.425V - 2.600V) 0x71 - 0x7F: 2.6V + (VSEL-0x70) * 50mV -> (2.650V - 3.350V)						
17h-2	CVDD2	PROG_CVDD2	VSEL_CVDD2<6:0> 0... OFF 0x01 - 0x40: 0.6V + VSEL * 12.5mV -> (0.6125V - 1.400V) 0x41 - 0x70: 1.4V + (VSEL-0x40) * 25mV -> (1.425V - 2.600V) 0x71 - 0x7F: 2.6V + (VSEL-0x70) * 50mV -> (2.650V - 3.350V)						
17h-3	reserved								
17h-4	reserved								
17h-5	reserved								
17h-6	Hibernation	-	KEEP_PVDD2	KEEP_PVDD1	-	-	-	KEEP_CVDD2	KEEP_CVDD1
17h-7	DCDC_Cntr	CVDD2_fast 0: Cext=10uF 1: Cext=22uF	CVDD1_fast 0: Cext=10uF 1: Cext=22uF	CVDD2_freq 0: 2MHz 1: 1MHz	CVDD1_freq 0: 2MHz 1: 1MHz	DVM_CVDD2<1:0> 0: immediate; 1: 42us/step; 2: 166us/step; 3: 666us/step	DVM_CVDD1<1:0> 0: immediate; 1: 42us/step; 2: 166us/step; 3: 666us/step		
18h-1	PVDD1	PVDD1_OFF	ILIM_H_PVDD1 0: 100mA 1: 200mA	PRG_PVDD1	VSEL_PVDD1<4:0> 0x00 - 0x0F: 1.2V + VSEL * 50mV -> (1.2V - 1.95V) 0x10 - 0x1F: 2.0V + (VSEL-0x10) * 100mV -> (2.0V - 3.5V)				
18h-2	PVDD2	PVDD2_OFF	ILIM_H_PVDD2 0: 100mA 1: 200mA	PRG_PVDD2	VSEL_PVDD2<4:0> 0x00 - 0x0F: 1.2V + VSEL * 50mV -> (1.2V - 1.95V) 0x10 - 0x1F: 2.0V + (VSEL-0x10) * 100mV -> (2.0V - 3.5V)				
18h-3	reserved								
18h-4	reserved								
18h-5	reserved								

Table 43. I2C Register Overview

Addr	Name	b7	b6	b5	b4	b3	b2	b1	b0
18h-6	AVDD27	-	ILIM_H_VDD27 0: 100mA 1: 200mA	PRG_AVDD27	-	VSEL_AVDD27<3:0> 0x0 - 0x2: 2.3V 0x3 - 0xF: 2.0V + VSEL * 100mV ->(2.3V - 3.5V)			
18h-7	AVDD17	AVDD17_OFF	-	PRG_AVDD17	VSEL_AVDD17<4:0> 0x00 - 0xF: 1.65V + VSEL * 50mV ->(1.65V - 3.2V)				
19h-1	CHGVBUS1	BAT_TEMP_OF	CHG_I<2:0> 0..3: 55, 70, 140, 210mA 4..7: 280, 350, 420, 460mA			CHG_V<2:0> 3.9V + CHG_V * 50mV ->(3.9V - 4.25V)			CHG_OFF
19h-2	CHGVBUS2	VBUS_COMP_TH	<1:0> 0: 4.5V; 1: 3.18V; 2: 1.5V; 3: 0.6V	-	-	BAT_TEMP 0: 0.4/0.5V; 1: 0.6/0.7V	CHG_EOC_TH<1:0> 0: 10% CC; 1: 30% CC; 2: 50% CC; 3: 70% CC		
1Ah-1	Out_Cntr1	DRIVE_PWGD<1:0>	DRIVE_PWGD<1:0> 0: 6mA OD; 1: 6mA PP; 2: 1mA PP; 3: HiZ	MUX_PWGD<1:0> 0: PWGD; 1: CLK24M; 2: CLKINT2; 3: PWM		DRIVE_XRES<1:0> 0: 6mA OD; 1: 6mA PP; 2: 1mA PP; 3: HiZ	MUX_XRES<1:0> 0: XRES; 1: CLK32K; 2: CLKINT1; 3: PWM		
1Ah-2	Out_Cntr2	DRIVE_Q24M<1:0>	DRIVE_Q24M<1:0> 0: 6mA PP; 1: HiZ; 2: 2mA PP; 3: 1mA PP	MUX_Q24M<1:0> 0: CLK24M; 1: CLKINT1; 2: CLKINT2; 3: PWM		DRIVE_Q32K<1:0> 0: 6mA PP; 1: HiZ; 2: 2mA PP; 3: 1mA PP	MUX_Q32K<1:0> 0: CLK32K; 1: CLKINT1; 2: CLKINT2; 3: PWM		
1Ah-3	Out_Cntr3	DRIVE_SDO<1:0>	DRIVE_SDO<1:0> 0: 6mA PP; 1: HiZ; 2: 2mA PP; 3: 1mA PP	MUX_SDO<1:0> 0: SDO; 1: CLK24M; 2: CLKINT1; 3: PWM		DRIVE_XIRQ<1:0> 0: 6mA OD; 1: 6mA PP; 2: 1mA PP; 3: HiZ	MUX_XIRQ<1:0> 0: XIRQ; 1: CLKINT1; 2: CLKINT2; 3: IRQ		
1Ah-4	In_Cntr	-	-	-	-	MUX_HBT<1:0> 0: OFF; 1: PWGD; 2: Q24M; 3: Q32K	MUX_ExtDim<1:0> 0: OFF; 1: PWGD; 2: Q24M; Q32K		
1Ah-5	Clk_Cntr	CLKINT2<1:0>	CLKINT2<1:0> 0: CLKPLL; 1: CLKloglim; 2: LOW; 3: HIGH	CLKINT1<1:0> 0: 2MHz; 1: 667kHz; 2: 1kHz; 3: 125Hz		CLK24M<1:0> 0: OSC24M; 1: OSC24M_div2; 2: OSC24M_div4; 3: OSC24M_PD	CLK32K<1:0> 0: OSC32K; 1: 1Hz; 2: LOW; 3: HIGH		
1Ah-6	PWM_Cntr	PWM_INVERT	PWM_CYCLE<6:0> 0: no pulses; 1-127: duty cycle = PWM_CYCLE * 0.39%						
1Ah-7	PLL	OSR<3:0> 0x0: 128; 0x1-0xF: n/a				VCO_MODE<1:0> 0: 24-48kHz; 1: 8-23kHz; 2: 49-96kHz; 3: n/a	PLL_MODE<1:0> 0: automatic; 1: ON; 2: OFF; 3: auto_inv		
1Bh-1	DCDC15	DIM_UP_XDO WN	DIM_RATE<1:0> 0: 0ms; 1: 300ms; 2: 600ms; 3: 1200ms	VFB_ON	ExtDim_ON				
1Bh-2	ISINK1	I_SINK1<4:0>	I_SINK1<4:0> 0: OFF; 1-31: 1.2mA * I; I_SINK1 -> (1.2mA...37.2mA)						
1Bh-3	ISINK2	I_SINK2<4:0>	I_SINK2<4:0> 0: OFF; 1-31: 1.2mA * I; I_SINK2 -> (1.2mA...37.2mA)						

Table 43. I2C Register Overview

Addr	Name	b7	b6	b5	b4	b3	b2	b1	b0	
1Ch	PMU_Enable	<b>DC_TEST_MUX &lt;3:0&gt;</b> 0: open; 1: AVDD27; 2: AVDD17; 3: PVDD1; 4: PVDD2; 5: CVDD1; 6: CVDD2; 7: RVDD; 8: FVDD; 9: PWGD; A-F: not defined								
<b>System Register</b>										
20h	SYSTEM	<b>Design_Version&lt;3:0&gt;</b> <b>HB_WD_ON</b>								
21h	SUPERVISOR	<b>SD_TIME</b> 0: 10s; 1: 5s	<b>BVDDlow_SD_</b> OFF VDD27-10%	-	<b>JTEMP_SUP&lt;4:0&gt;</b> Temp_ShutDown = 140°C - JTEMP_SUP+5°C -> (140°C...- 15°C) Temp_IRQ = 120°C - JTEMP_SUP+5°C -> (120°C...-35°C)	<b>JTEMP_OFF</b>	<b>I2C_WD_ON</b>	<b>I2C_WD_ON</b>	<b>PWR_HOLD</b>	
1st write/read:										
<b>WAKE_UP_BYTE_0</b>										
		128s	64s	32s	16s	8s	4s	2s	1s	
2nd write/read:										
<b>WAKE_UP_BYTE_1</b>										
		32ks	16ks	8ks	4ks	2ks	1ks	512s	256s	
3rd write/read:										
<b>WAKE_UP_BYTE_2</b>										
		WAKEUP_	4Ms	2Ms	1Ms	512ks	256ks	128ks	64ks	
4th to 19th write/read: non volatile memory bytes<0:15>										
<b>SRAM_128&lt;0:15&gt;</b>										
23h	IRQENRD_0	CVDD1_SD	CVDD1_IRQ	-	-	PVDD2_SD	PVDD2_IRQ	PVDD1_SD	PVDD1_IRQ	
		CVDD1_under	CVDD1_over	-	-	PVDD2_under	PVDD2_over	PVDD1_under	PVDD1_over	
24h	IRQENRD_1	PWRUP_IRQ	WAKEUP_IRQ	MCLK_IRQ	-	-	-	CVDD2_SD	CVDD2_IRQ	
		BATTEMP_IRQ	-	-	CHG_IRQ	-	USB_IRQ	CVDD2_under	CVDD2_over	
25h	IRQENRD_2	JTEMP_HIGH	CHG_EOC	HP_OVC	CHG_CON	CHG_CHANGED	USB_CON	RTC_WD	BVDD_LOW	
26h	IRQENRD_3	T_DEB<1:0>	-	-	I2S_STATUS	I2S_CHANGED	VOXM_IRQ	MIC_CON	HPH_CON	
		0: 512ms; 1: 256ms; 2: 128ms; 3: 8ms	-	-	AVDD27_IRQ	DCDC15_IRQ	REM_DET	RTC_UPDATE	ADC_EOC	
27h	IRQENRD_4	Free_Bits<3:0>	to be used for application purpose							OSC_ON
28h	RTC_Cntr	IRQ_MIN	TRTC<6:0>							
29h	RTC_Time	QRTC<7:0>								
2Ah	RTC_0									

Table 43. I2C Register Overview

Addr	Name	b7	b6	b5	b4	b3	b2	b1	b0
2Bh	RTC_1	QRTC<15:8>							
2Ch	RTC_2	QRTC<23:16>							
2Dh	RTC_3	QRTC<31:24>							
2Eh	ADC10_0	ADC10_MUX<3:0> 0: BVDDR; 1: BVDDR; 2: CHGIN; 3: CHGOUT; 4: VBUS 5: DC_TEST; 6: BATTEMP; 7: MCLK; 8: MICS; A: LMICS; C: VBE_1uA; D: VBE_2uA; E: L_CHGact; F: L_CHGref							
2Fh	ADC10_1	ADC10<7:0>							
<b>UID Register</b>									
38h	UID_0	ID<7:0>							
39h	UID_1	ID<15:8>							
3Ah	UID_2	ID<23:16>							
3Bh	UID_3	ID<31:24>							
3Ch	UID_4	ID<39:32>							
3Dh	UID_5	ID<47:40>							
3Eh	UID_6	ID<55:48>							
3Fh	UID_7	ID<63:56>							

Table 44. OUT\_R Register

Name		Base		Default
OUT_R		2-wire serial		00h
Offset: 02h		Right HP/Line Output Register		
		Configures MUX_C and the audio gain from MUX_C output to HPR/LOUTR output and switches between the headphone and line output. This register is reset when the block is disabled in AudioSet1 register (14h) or at a AVDD27-POR. The register cannot be written when the block is disabled.		
Bit	Bit Name	Default	Access	Bit Description
7	LOUT	0	R/W	Switches between headphone and line output <b>00: headphone enabled</b> 01: line out enabled
6:5	MUX_C<1:0>	00	R/W	Multiplexes the analog audio inputs to MUX_C output for HPR/L and LOUTR/L <b>00: Mixer: ΣR to HPR/LOUTR and ΣL to HPL/LOUTL</b> 01: DAC direct : (N19/ N22), DAC gain stage and mixer are bypassed 10: LineIn direct (N10/N17) 11: Mic direct (N12/N13)
4:0	OUTR_VOL<4:0>	00000	R/W	volume settings for right headphone/line output, adjustable in 32 steps @ 1.5dB; gain from MUX_C to HPR/LOUTR 11111: 6 dB gain 11110: 4.5 dB gain .. 00001: -39 dB gain <b>00000: -40.5 dB gain</b>

Table 45. OUT\_L Register

Name		Base		Default
OUT_L		2-wire serial		00h
Offset: 03h		Left HP/Line Output Register		
		Configures the audio gain from MUX_C output to HPL/LOUTL output and controls MUTE switch K as well as on/off of the stage. This register is reset when the stage is disabled in AudioSet1 register (14h) or at a AVDD27-POR. The register cannot be written when the block is disabled		
Bit	Bit Name	Default	Access	Bit Description
7	MUTE_K_ON	0	R/W	Control of MUTE switch K <b>0: HP/line output set to mute</b> 1: normal operation
6	STAGE_ON	0	R/W	<b>0: HP/line stage not powered</b> 1: normal operation
5	HPDET_ON	0	R/W	Enables the detection when a headset gets connected. HPCM is used as a sense pin and is biased to 150mV <b>0: no headphone detection</b> 1: enable headphone detection
4:0	OUTL_VOL<4:0>	00000	R/W	volume settings for left headphone/line output, adjustable in 32 steps @ 1.5dB; gain from MUX_C to HPL/LOUTL 11111: 6 dB gain 11110: 4.5 dB gain .. 00001: -39 dB gain <b>00000: -40.5 dB gain</b>

Table 46. MIC\_R Register

Name		Base		Default
MIC_R		2-wire serial		00h
Offset: 06h		Right Microphone Input Register		
		Configures MUX_C and the audio gain from MUX_C output to HPR/LOUTR output and switches between the headphone and line output. This register is reset at a AVDD27-POR.		
Bit	Bit Name	Default	Access	Bit Description
7	MIC_MODE	0	R/W	Selects the microphone input mode <b>0: mono differential mode</b> 1: single ended mode
6:5	PRE_GAIN<1:0>	00	R/W	Sets the gain of the microphone preamplifier (gain from microphone inputs to N3) <b>00: gain set to 30 dB</b> 01: gain set to 36 dB 10: gain set to 42 dB 11: reserved, do not use.
4:0	MICR_VOL<4:0>	00000	R/W	volume settings for right microphone input, adjustable in 32 steps @ 1.5dB; gain from microphone amplifier (N4) to mixer input (N12) 11111: 6 dB gain 11110: 4.5 dB gain .. 00001: -39 dB gain <b>00000: -40.5 dB gain</b>

Table 47. MIC\_L Register

Name		Base		Default
MIC_L		2-wire serial		00h
Offset: 07h		Left Microphone Input Register		
		Configures the gain from microphone amplifier output up to mixer input ( $\Sigma$ ) and controls MUTE switch D. This register is reset at a AVDD27-POR.		
Bit	Bit Name	Default	Access	Bit Description
7	MSUP_OFF	0	R/W	<b>0: microphone supply enabled</b> 1: microphone supply disabled
6	MUTE_D_ON	0	R/W	Control of MUTE switch D <b>0: normal operation</b> 1: microphone input set to mute
5	-	0	n/a	
4:0	MICL_VOL<4:0>	00000	R/W	volume settings for left microphone input, adjustable in 32 steps @ 1.5dB; gain from microphone amplifier (N4) to mixer input (N13) 11111: 6 dB gain 11110: 4.5 dB gain .. 00001: -39 dB gain <b>00000: -40.5 dB gain</b>

Table 48. LINE\_IN\_R Register

Name		Base		Default
LINE_IN_R		2-wire serial		00h
Offset: 0Ah		Right Line Input Register		
		Configures the gain from right analog line input MUX E to mixer input ( $\Sigma$ ) and controls MUTE switch B. This register is reset when the block is disabled in AudioSet1 register (14h) or at a AVDD27-POR. The register cannot be written when the block is disabled.		
Bit	Bit Name	Default	Access	Bit Description
7	LI_HIQ	0	R/W	<b>0: line input set to low power mode</b> 1: line input set to high quality mode
6	MUX_E	0	R/W	Selects the line input <b>0: MUX_E output connected to Line Input 1</b> 1: MUX_E output connected to Line Input 2
5	MUTE_B_OFF	0	R/W	Control of MUTE switch B <b>0: right line input is set to mute</b> 1: normal operation
4:0	LIR_VOL<4:0>	00000	R/W	volume settings for right line input, adjustable in 32 steps @ 1.5dB; gain from MUX output (N27) to mixer input (N10) 11111: 6 dB gain 11110: 4.5 dB gain .. 00001: -39 dB gain <b>00000: -40.5 dB gain</b>

Table 49. LINE\_IN\_L Register

Name		Base		Default
LINE_IN_L		2-wire serial		00h
Offset: 0Bh		Left Line Input Register		
		Configures the gain from analog left line input MUX E to mixer input ( $\Sigma$ ) and controls MUTE switch G. This register is reset when the block is disabled in AudioSet1 register (14h) or at a AVDD27-POR. The register cannot be written when the block is disabled.		
Bit	Bit Name	Default	Access	Bit Description
7	LO_DISCHG_OFF	0	R/W	<b>0: normal operation</b> 1: disables discharge resistors. Need if the line output is directly connected to the line input for using the same connector.
6	LI_MODE	0	R/W	Selects the line input mode <b>0: stereo</b> 1: 2x mono single ended
5	MUTE_G_OFF	0	R/W	Control of MUTE switch G <b>0: left line input is set to mute</b> 1: normal operation
4:0	LIL_VOL<4:0>	00000	R/W	volume settings for left line input, adjustable in 32 steps @ 1.5dB; gain from MUX output (N28) to mixer input (N17) 11111: 6 dB gain 11110: 4.5 dB gain .. 00001: -39 dB gain <b>00000: -40.5 dB gain</b>

Table 50. DAC\_R Register

Name		Base		Default
DAC_R		2-wire serial		00h
Offset: 0Eh		Right DAC Output Register		
		Configures the gain from DAC output to mixer input ( $\Sigma$ ). This register is reset when the block is disabled in AudioSet1 register (14h) or at a AVDD27-POR. The register cannot be written when the block is disabled.		
Bit	Bit Name	Default	Access	Bit Description
7:5	-	000	n/a	
4:0	DAR_VOL<4:0>	00000	R/W	volume settings for right DAC output, adjustable in 32 steps @ 1.5dB; gain from DAC output (N19) to mixer input (N23) 11111: 6 dB gain 11110: 4.5 dB gain .. 00001: -39 dB gain <b>00000: -40.5 dB gain</b>

Table 51. DAC\_L Register

Name		Base		Default
DAC_L		2-wire serial		00h
Offset: 0Fh		Left DAC Output Register		
		Configures the gain from DAC output to mixer input ( $\Sigma$ ) and controls MUTE switch H. This register is reset when the block is disabled in AudioSet1 register (14h) or at a AVDD27-POR. The register cannot be written when the block is disabled.		
Bit	Bit Name	Default	Access	Bit Description
7:6	-	00	n/a	
5	MUTE_H_OFF	0	R/W	Control of MUTE switch H <b>0: DAC output is set to mute</b> 1: normal operation
4:0	DAL_VOL<4:0>	00000	R/W	volume settings for left DAC output, adjustable in 32 steps @ 1.5dB; gain from DAC output (N22) to mixer input (N26) 11111: 6 dB gain 11110: 4.5 dB gain .. 00001: -39 dB gain <b>00000: -40.5 dB gain</b>

Table 52. ADC\_R Register

Name		Base		Default
ADC_R		2-wire serial		00h
Offset: 10h		Right ADC Input Register		
		Configures MUX_A and the gain from MUX_A output to the ADC/mixer input ( $\Sigma$ ). This register is reset when the block is disabled in AudioSet1 register (14h) or at a AVDD27-POR. The register cannot be written when the block is disabled.		
Bit	Bit Name	Default	Access	Bit Description
7:6	MUX_A<1:0>	00	R/W	Connect MUX A output to following inputs <b>00: Microphone (N4/N4)</b> 01: Line_In1 (N1/N8) 10: Line_IN2 (N2/N7) 11: Mixer output (N24/N25)
5	-	0	n/a	
4:0	ADR_VOL<4:0>	00000	R/W	volume settings for right ADC input, adjustable in 32 steps @ 1.5dB; gain from MUX A output to ADC/mixer input ( $\Sigma$ ) (N9) 11111: 12 dB gain 11110: 10.5 dB gain .. 00001: -33 dB gain <b>00000: -34.5 dB gain</b>

Table 53. ADC\_L Register

Name		Base		Default
ADC_L		2-wire serial		00h
Offset: 0Fh		Left ADC Input Register		
		Configures the ADC mode, gain from MUX_A output to the ADC/mixer input ( $\Sigma$ ) input and controls MUTE switch A. This register is reset when the block is disabled in AudioSet1 register (14h) or at a AVDD27-POR. The register cannot be written when the block is disabled.		
Bit	Bit Name	Default	Access	Bit Description
7:6	ADC_MODE<1:0>	00	R/W	Devdiver setting for ADC sampling frequency <b>00: I2S LRCK / 2</b> 01: I2S LRCK / 4 10: I2S LRCK 11: I2S LRCK
5	MUTE_A_OFF	0	R/W	Control of MUTE switch A <b>0: ADC input is set to mute</b> 1: normal operation
4:0	ADL_VOL<4:0>	00000	R/W	volume settings for left ADC input, adjustable in 32 steps @ 1.5dB; gain from MUX A output to ADC/mixer input ( $\Sigma$ ) (N18) 11111: 6 dB gain 11110: 4.5 dB gain .. 00001: -39 dB gain <b>00000: -40.5 dB gain</b>

Table 54. DAC\_IF Register

Name		Base		Default
DAC_IF		2-wire serial		00h
Offset: 12h		DAC Interface Register		
		Configures the DAC interface and digital gain on the I2S input stream. This register is reset at a AVDD27-POR.		
Bit	Bit Name	Default	Access	Bit Description
7	I2S_DIRECT	0	R/W	<b>0: I2S master clock is generated by the internal PLL</b> 1: signal on MCLK is used as I2S master clock
6	I2S_LOOP	0	R/W	<b>0: normal operation</b> 1: ADC output is connected to DAC input
5	I2S_ATTEN	0	R/W	<b>0: normal operation</b> 1: digital attenuation on I2S input data (SDI) enabled
4:0	SDI_ATTEN<4:0>	00000	R/W	digital volume settings I2S input data (SDI), adjustable in 32 steps @ 1.5dB; gain from SDI pin to DAC input 11111: -1.5 dB gain 11110: -3 dB gain .. 00001: -46.5 dB gain <b>00000: -48.0 dB gain</b>

Table 55. AudioSet1 Register

Name		Base		Default
AudioSet1		2-wire serial		00h
Offset: 14h		First Audio Set Register		
		Powers the various audio inputs and outputs UP or DOWN. <b>Caution:</b> This control register resets and holds LineIn, DAC, and ADC related registers in reset. After activation the required register settings need to be re-programmed. This register is reset at a AVDD27-POR.		
Bit	Bit Name	Default	Access	Bit Description
7	ADC_ON	0	R/W	<b>0: ADC powered down</b> 1: ADC enabled for recording
6	DAC_ON	0	R/W	<b>0: DAC powered down</b> 1: DAC enabled for playback
5	DAC_GST_ON	0	R/W	<b>0: DAC gainstage powered down</b> 1: DAC gainstage enabled (needed for playback via mixer)
4:3	-	00	n/a	
2	LIN_ON	0	R/W	<b>0: Line Input powered down</b> 1: Line Input enabled
1	-	0	n/a	
0	MIC_ON	0	R/W	<b>0: Microphone Input powered down</b> 1: Microphone Input enabled

Table 56. AudioSet2 Register

Name		Base		Default
AudioSet2		2-wire serial		00h
Offset: 15h		Second Audio Set Register		
Control of various audio blocks. This register is reset at a AVDD27-POR.				
Bit	Bit Name	Default	Access	Bit Description
7	BIAS_OFF	0	R/W	Power-down of the AGND bias if only digital data transfer and PMU functions are used. <b>0: bias enabled</b> 1: bias disabled, for power saving in non audio mode
6	SUM_OFF	0	R/W	<b>0: Mixer stage enabled</b> 1: Mixer stage powered down
5	SUM_AGC_OFF	0	R/W	Switches the signal limiter OFF (N20/N21) <b>0: automatic gain control for summing stage enabled</b> 1: automatic gain control for summing stage disabled
4	SUM_HP_HIQ	0	R/W	<b>0: mixer and headphone stage in low power mode</b> 1: mixer and headphone stage in high quality mode
3:2	GAIN_STEP<1:0>	00	R/W	Sets the transition time of the auto fading for the output stage <b>00: 2ms/step</b> 01: 4ms/step 10: 8ms/step 11: auto fading off
1:0	VMICS<1:0>	00	R/W	Sets the microphone supply output voltage <b>00: AVDD17*20/17</b> 01: AVDD17*20/22 10: AVDD17*20/27 11: AVDD17*20/32

Table 57. AudioSet3 Register

Name		Base		Default
AudioSet3		2-wire serial		00h
Offset: 16h		Third Audio Set Register		
Control of mixer stage inputs and headphone. This register is reset at a AVDD27-POR.				
Bit	Bit Name	Default	Access	Bit Description
7	-	0	n/a	
6	MICMIX_OFF	0	R/W	<b>0: microphone input to ΣR and ΣL (N12/N13) on</b> 1: microphone input to mixer disabled
5	-	0	n/a	
4	ADCMIX_ON	0	R/W	<b>0: ADC input to mixer disabled</b> 1: ADC input to ΣR and ΣL (N12/N13) on
3	LINMIX_OFF	0	R/W	<b>0: line input to ΣR and ΣL (N12/N13) on</b> 1: line input to mixer disabled
2	HP_FASTSTART	0	R/W	<b>0: normal operation</b> 1: shortens delay for start-up when using 220nF on HPGND
1	HP_BIAS	0	R/W	<b>0: 100%</b> 1: 150%, increased bias for lower noise and THD
0	HPCM_ON	0	R/W	<b>0: headphone common mode buffer is switched off</b> 1: headphone common mode buffer is powered up

Table 58. CVDD1 Register

Name		Base		Default
CVDD1		2-wire serial		00h
Offset: 17h-1		CVDD1 DC/DC Buck Regulator Control Register		
		This is an extended register and needs to be enabled by writing 001b to Reg. 1Ch first. This register is reset at a AVDD27-POR.		
Bit	Bit Name	Default	Access	Bit Description
7	PROG_CVDD1	0	R/W	Selects the control mode for CVDD1 <b>0: CVDD1 is in default mode controlled by pin VPRG1</b> 1: CVDD1 is register controlled (Reg. 17-1h)
6:0	VSEL_CVDD1>6:0>	000000	R/W	The voltage select bits set the DC/DC output voltage level and power the DC/DC converter down. <b>00h: DC/DC powered down</b> 01h-40h: CVDD1=0.6V+VSEL_CVDD1*12.5mV 41h-70h: CVDD1=1.4V+(VSEL_CVDD1-40h)*25mV 71h-7Fh: CVDD1=2.6V+(VSEL_CVDD1-70h)*50mV

Table 59. CVDD2 Register

Name		Base		Default
CVDD2		2-wire serial		00h
Offset: 17h-2		CVDD2 DC/DC Buck Regulator Control Register		
		This is an extended register and needs to be enabled by writing 010b to Reg. 1Ch first. This register is reset at a AVDD27-POR.		
Bit	Bit Name	Default	Access	Bit Description
7	PROG_CVDD2	0	R/W	Selects the control mode for CVDD2 <b>0: CVDD2 is in default mode controlled by pin VPRG2</b> 1: CVDD2 is register controlled (Reg. 17-1h)
6:0	VSEL_CVDD2<6:0>	000000	R/W	The voltage select bits set the DC/DC output voltage level and power the DC/DC converter down. <b>00h: DC/DC powered down</b> 01h-40h: CVDD1=0.6V+VSEL_CVDD2*12.5mV 41h-70h: CVDD1=1.4V+(VSEL_CVDD2-40h)*25mV 71h-7Fh: CVDD1=2.6V+(VSEL_CVDD2-70h)*50mV

Table 60. Hibernation Register

Name		Base		Default
Hibernation		2-wire serial		00h
Offset: 17h-6		PMU Hibernation Control Register		
		Hibernation starts when writing this register. This is an extended register and needs to be enabled by writing 110b to Reg. 1Ch first. This register is reset at a AVDD27-POR.		
Bit	Bit Name	Default	Access	Bit Description
7	-	0	n/a	
6	KEEP_PVDD2	0	R/W	Keeps the programmed PVDD2 level during hibernation. <b>0: power down PVDD2</b> 1: keep PVDD2
5	KEEP_PVDD1	0	R/W	Keeps the programmed PVDD1 level during hibernation. <b>0: power down PVDD1</b> 1: keep PVDD1
4:2	-	000	n/a	
1	KEEP_CVDD2	0	R/W	Keeps the programmed CVDD2 level during hibernation. <b>0: power down CVDD2</b> 1: keep CVDD2
0	KEEP_CVDD1	0	R/W	Keeps the programmed PVDD1 level during hibernation. <b>0: power down CVDD1</b> 1: keep CVDD1

Table 61. DCDC\_Cntr Register

Name		Base		Default
DCDC_Cntr		2-wire serial		00h
Offset: 17h-7		DC/DC Step Down Control Register		
		This is an extended register and needs to be enabled by writing 111b to Reg. 1Ch first. This register is reset at a AVDD27-POR.		
Bit	Bit Name	Default	Access	Bit Description
7	CVDD2_fast	0	R/W	Selects a faster regulation mode for CVDD2 suitable for larger load changes. <b>0: normal mode, Cext=10uF</b> 1: fast mode, Cext=22uF required
6	CVDD1_fast	0	R/W	Selects a faster regulation mode for CVDD1 suitable for larger load changes. <b>0: normal mode, Cext=10uF</b> 1: fast mode, Cext=22uF required
5	CVDD2_freq	0	R/W	Selects the switching frequency for DCDC2 <b>0: 2MHz</b> 1: 1MHz
4	CVDD1_freq	0	R/W	Selects the switching frequency for DCDC2 <b>0: 2MHz</b> 1: 1MHz

Table 61. DCDC\_Cntr Register

Name		Base		Default
DCDC_Cntr		2-wire serial		00h
Offset: 17h-7		DC/DC Step Down Control Register		
		This is an extended register and needs to be enabled by writing 111b to Reg. 1Ch first. This register is reset at a AVDD27-POR.		
Bit	Bit Name	Default	Access	Bit Description
3:2	DVM_CVDD2<1:0>	00	R/W	Configures the dynamic voltage management (output voltage slope) for CVDD2 <b>00: immediate change of the output voltage</b> 01: 42us/step 02: 166us/step 03: 666us/step
1:0	DVM_CVDD1<1:0>	00	R/W	Configures the dynamic voltage management (output voltage slope) for CVDD1 <b>00: immediate change of the output voltage</b> 01: 42us/step 02: 166us/step 03: 666us/step

Table 62. PVDD1 Register

Name		Base		Default
PVDD1		2-wire serial		00h
Offset: 18h-1		PVDD1 Control Register		
		This is an extended register and needs to be enabled by writing 001b to Reg. 1Ch first. This register is reset at a AVDD27-POR.		
Bit	Bit Name	Default	Access	Bit Description
7	PVDD1_OFF	0	R/W	Switches off PVDD1 regulator <b>0: normal mode</b> 1: PVDD1 switched off
6	ILIM_H_PVDD1	0	R/W	Selects the higher current limit for PVDD1 <b>0: default mode, 100mA</b> 1: 200mA mode
5	PRG_PVDD1	0	R/W	Selects the output voltage control mode for PVDD1 <b>0: PVDD1 is in default mode controlled by pin VPRG2</b> 1: PVDD1 is register controlled (Reg. 18-1h)
4:0	VSEL_PVDD1<4:0>	00000	R/W	Sets the LDO output voltage in register control mode (default voltage of the regulator is selected by pin VPROG2) 0x00-0x0F: 1.2V+VSEL*50mV ->(1.2V - 1.95V) 0x10-0x1F: 2.0V + (VSEL-0x10)*100mV -> (2.0V-3.5V)

Table 63. PVDD2 Register

Name		Base		Default
PVDD2		2-wire serial		00h
Offset: 18h-2		PVDD2 Control Register		
		This is an extended register and needs to be enabled by writing 010b to Reg. 1Ch first. This register is reset at a AVDD27-POR.		
Bit	Bit Name	Default	Access	Bit Description
7	PVDD2_OFF	0	R/W	Switches off PVDD2 regulator <b>0: normal mode</b> 1: PVDD1 switched off
6	ILIM_H_PVDD2	0	R/W	Selects the higher current limit for PVDD2 <b>0: default mode, 100mA</b> 1: 200mA mode
5	PRG_PVDD2	0	R/W	Selects the output voltage control mode for PVDD2 <b>0: PVDD2 is in default mode controlled by pin VPRG2</b> 1: PVDD2 is register controlled (Reg. 18-2h)
4:0	VSEL_PVDD2<4:0>	00000	R/W	Sets the LDO output voltage in register control mode (default voltage of the regulator is selected by pin VPRG2) 0x00-0x0F: 1.2V+VSEL*50mV ->(1.2V - 1.95V) 0x10-0x1F: 2.0V + (VSEL-0x10)*100mV -> (2.0V-3.5V)

Table 64. AVDD27 Register

Name		Base		Default
AVDD27		2-wire serial		00h
Offset: 18h-6		AVDD27 Control Register		
		This is an extended register and needs to be enabled by writing 110b to Reg. 1Ch first. This register is reset at a AVDD27-POR.		
Bit	Bit Name	Default	Access	Bit Description
7	-	0	n/a	
6	ILIM_H_VDD27	0	R/W	Selects the higher current limit for AVDD27 <b>0: default mode, 100mA</b> 1: 200mA mode
5	PRG_AVDD27	0	R/W	Selects the output voltage control mode for AVDD27 <b>0: AVDD27 is in default mode (2.7V)</b> 1: AVDD27 is register controlled (Reg. 18-6h)
5	-	0	n/a	
3:0	VSEL_AVDD27<3:0>	0000	R/W	Sets the LDO output voltage in register control mode (default voltage of the regulator is 2.7V) 0x0-0x2: 2.3V 0x3-0xF: 2.0V + VSEL*100mV -> (2.3V-3.5V)

Table 65. AVDD17 Register

Name		Base		Default
AVDD17		2-wire serial		00h
Offset: 18h-7		AVDD17 Control Register		
		This is an extended register and needs to be enabled by writing 111b to Reg. 1Ch first. This register is reset at a AVDD27-POR.		
Bit	Bit Name	Default	Access	Bit Description
7	AVDD17_OFF	0	R/W	Switches off AVDD17 regulator <b>0: normal mode</b> 1: AVDD17 switched off, no audio functions possible
6	-	0	n/a	
5	PRG_AVDD17	0	R/W	Selects the output voltage control mode for AVDD17 <b>0: AVDD17 is in default mode (1.7V)</b> 1: AVDD17 is register controlled (Reg. 18-7h)
4:0	VSEL_AVDD17<4:0>	0000	R/W	Sets the LDO output voltage in register control mode (default voltage of the regulator is 1.7V) 0x00-0x1F: 1.65V + VSEL*100mV -> (1.65V-3.2V)

Table 66. CHGVBUS1 Register

Name		Base		Default
CHGVBUS1		2-wire serial		00h
Offset: 19h-1		Charger / VBUS 1 Control Register		
		This is an extended register and needs to be enabled by writing 001b to Reg. 1Ch first. This register is reset at a AVDD27-POR.		
Bit	Bit Name	Default	Access	Bit Description
7	BAT_TEMP_OFF	0	R/W	<b>0: enables 15uA supply for external 100k NTC resistor</b> 1: disables supply
6:4	CHG_I<2:0>	000	R/W	set maximum charging current during constant current charging 111: 460 mA 110: 420 mA 101: 350 mA 100: 280 mA 011: 210 mA 010: 140 mA 001: 70 mA <b>000: 55 mA</b>
3:1	CHG_V<2:0>	000	R/W	set maximum charger voltage in 50mV steps for the constant voltage charging 111: 4.25 V 110: 4.2 V .. 001: 3.95 V <b>000: 3.9 V</b>
0	CHG_OFF	0	R/W	<b>0: enables Charger</b> 1: disables Charger

Table 67. CHGVBUS2 Register

Name		Base		Default
CHGVBUS2		2-wire serial		00h
Offset: 19h-2		Charger / VBUS 2 Control Register		
		This is an extended register and needs to be enabled by writing 010b to Reg. 1Ch first. This register is reset at a AVDD27-POR.		
Bit	Bit Name	Default	Access	Bit Description
7:6	VBUS_COMP_TH <1:0>	00	R/W	Sets the threshold for the VBUS comparator. The output can be read in register 25h. <b>00: 4.5V</b> 01: 3.18V 10: 1.5V 11: 0.6V
5:3	-	000	n/a	-
2	BAT_TEMP	0	R/W	Selects the battery temperature supervision level <b>0: 0.4/0.5V equal to 55/50°C with 100k NTC</b> 1: 0.6/0.7V equal to 45/42°C with 100k NTC
1:0	CHG_EOC_TH<1:0>	00	R/W	Setes the threshold for the charger EOC (end of charge) interrupt as a ratio of the constant current (CC) setting. <b>00: 10% CC</b> 01: 30% CC 10: 50% CC 11: 70% CC

Table 68. Out\_Cntr1 Register

Name		Base		Default
Out_Cntr1		2-wire serial		00h
Offset: 1Ah-1		PWGD and XRES Output Control Register		
		This is an extended register and needs to be enabled by writing 001b to Reg. 1Ch first. This register is reset at a AVDD27-POR.		
Bit	Bit Name	Default	Access	Bit Description
7:6	DRIVE_PWGD<1:0>	00	R/W	Sets the PWGD output pin to open-drain, push-pull or tri-state and sets various driving strengths <b>00: 6mA open-drain output</b> 01: 6mA push-pull output 10: 1mA push-pull output 11: HiZ, stri-state
5:4	MUX_PWGD<1:0>	00	R/W	Multiplexes various digital signals to the PWGD output pin <b>00: PWGD, PowerGood control signal</b> 01: CLK24M, 24MHz oscillator output 10: CLKINT2, internal clock signal, see Clk_Cntr register 11: PWM, PMW_Cntr register

Table 68. Out\_Cntr1 Register

Name		Base		Default
Out_Cntr1		2-wire serial		00h
Offset: 1Ah-1		PWGD and XRES Output Control Register		
		This is an extended register and needs to be enabled by writing 001b to Reg. 1Ch first. This register is reset at a AVDD27-POR.		
Bit	Bit Name	Default	Access	Bit Description
3:2	DRIVE_XRES<1:0>	00	R/W	Sets the XRES output pin to open-drain, push-pull or tri-state and sets various driving strengths <b>00: 6mA open-drain output</b> 01: 6mA push-pull output 10: 1mA push-pull output 11: HiZ, stri-state
1:0	MUX_XRES<1:0>	00	R/W	Multiplexes various digital signals to the XRES output pin <b>00: XRES, active low reset signal</b> 01: CLK32k, 32kHz RTC oscillator output 10: CLKINT1, internal clock signal, see Clk_Cntr register 11: PWM, PMW_Cntr register

Table 69. Out\_Cntr2 Register

Name		Base		Default
Out_Cntr2		2-wire serial		00h
Offset: 1Ah-2		Q24M and Q32k Output Control Register		
		This is an extended register and needs to be enabled by writing 010b to Reg. 1Ch first. This register is reset at a AVDD27-POR.		
Bit	Bit Name	Default	Access	Bit Description
7:6	DRIVE_Q24M<1:0>	00	R/W	Sets the PWGD output pin to push-pull or tri-state and sets various driving strengths <b>00: 6mA push-pull output</b> 01: HiZ, stri-state 10: 2mA push-pull output 11: 1mA push-pull output
5:4	MUX_Q24M<1:0>	00	R/W	Multiplexes various digital signals to the PWGD output pin <b>00: CLK24M, 24MHz oscillator output signal</b> 01: CLKINT1, internal clock signal, see Clk_Cntr register 10: CLKINT2, internal clock signal, see Clk_Cntr register 11: PWM, PMW_Cntr register
3:2	DRIVE_Q32k<1:0>	00	R/W	Sets the XRES output pin to push-pull or tri-state and sets various driving strengths <b>00: 6mA push-pull output</b> 01: HiZ, stri-state 10: 2mA push-pull output 11: 1mA push-pull output
1:0	MUX_Q32k<1:0>	00	R/W	Multiplexes various digital signals to the XRES output pin <b>00: CLK32k, 32kHz RTC oscillator output signal</b> 01: CLKINT1, internal clock signal, see Clk_Cntr register 10: CLKINT2, internal clock signal, see Clk_Cntr register 11: PWM, PMW_Cntr register

Table 70. Out\_Cntr3 Register

Name		Base		Default
Out_Cntr3		2-wire serial		00h
Offset: 1Ah-3		SDO and XIRQ Output Control Register		
		This is an extended register and needs to be enabled by writing 011b to Reg. 1Ch first. This register is reset at a AVDD27-POR.		
Bit	Bit Name	Default	Access	Bit Description
7:6	DRIVE_SDO<1:0>	00	R/W	Sets the SDO output pin to push-pull or tri-state and sets various driving strengths <b>00: 6mA push-pull output</b> 01: HiZ, stri-state 10: 2mA push-pull output 11: 1mA push-pull output
5:4	MUX_SDO<1:0>	00	R/W	Multiplexes various digital signals to the SDO output pin <b>00: SDO, serial data output of the audio ADC</b> 01: CLK24M, 24MHz oscillator output 10: CLKINT1, internal clock signal, see Clk_Cntr register 11: PWM, PMW_Cntr register
3:2	DRIVE_XIRQ<1:0>	00	R/W	Sets the XIRQ output pin to open-drain, push-pull or tri-state and sets various driving strengths <b>00: 6mA open-drain output</b> 01: 6mA push-pull output 10: 1mA push-pull output 11: HiZ, stri-state
1:0	MUX_XIRQ<1:0>	00	R/W	Multiplexes various digital signals to the XRES output pin <b>00: XIRQ, active low interrupt request signal</b> 01: CLKINT1, internal clock signal, see Clk_Cntr register 10: CLKINT2, internal clock signal, see Clk_Cntr register 11: IRQ, active low reset signal

Table 71. In\_Cntr Register

Name		Base		Default
In_Cntr		2-wire serial		00h
Offset: 1Ah-4		HBT and Dimming Input Control Register		
		This is an extended register and needs to be enabled by writing 100b to Reg. 1Ch first. This register is reset at a AVDD27-POR.		
Bit	Bit Name	Default	Access	Bit Description
7:4	-	0000	n/a	
3:2	MUX_HBT<1:0>	00	R/W	Selects the HBT (heartbeat) input pin <b>00: OFF, heartbeat input deactivated</b> 01: PWGD pin 10: Q24M pin 11: Q32k pin
1:0	MUX_ExtDim<1:0>	00	R/W	Selects the input pin for external dimming of the DCDC15 <b>00: OFF, no pin selected</b> In this mode the current sinks can be used without enabling the DCDC15. ExtDim_ON bit has to be set in DCDC15 register. 01: PWGD pin 10: Q24M pin 11: Q32k pin

Table 72. Clk\_Cntr Register

Name		Base		Default
Clk_Cntr		2-wire serial		00h
Offset: 1Ah-5		Clock Control Register		
		This is an extended register and needs to be enabled by writing 101b to Reg. 1Ch first. This register is reset at a AVDD27-POR.		
Bit	Bit Name	Default	Access	Bit Description
7:6	CLKINT2<1:0>	00	R/W	Selects the CLKINT2 input source. Note, this is an internal clock, which can be multiplexed to one of the GPIO ouptus. <b>00: CLKPLL, internal PLL clock</b> 01: CLKlogdim, clock used for dimming the DCDC15 10: LOW, drives the signal to logic "0" 11: HIGH, drives the signal to logic "1"
5:4	CLKINT1<1:0>	00	R/W	Selects the CLKINT1 frequency. Note, this is an internal clock, which can be multiplexed to one of the GPIO ouptus. <b>00: 2MHz</b> 01: 887kHz 10: 1kHz 11: 125Hz
3:2	CLK24M<1:0>	00	R/W	Selects the CLK24M frequency, clock of 24MHz oszillator <b>00: OSC24MHz, oszillator frequency</b> 01: OSC24MHz_div2, oszillator frequency divided by 2 10: OSC24MHz_div4, oszillator frequency divided by 4 11: OSC24MHz_PD, OSC24M is set to power down
1:0	CLK32k<1:0>	00	R/W	Selects the CLK32k frequency, clock of 32kHz RTC oszillator <b>00: OSC32kHz, RTC oszillator frequency</b> 01: 1Hz 10: LOW, drives the signal to logic "0" 11: HIGH, drives the signal to logic "1"

Table 73. PWM\_Cntr Register

Name		Base		Default
PWM_Cntr		2-wire serial		00h
Offset: 1Ah-6		PWM Control Register		
		This is an extended register and needs to be enabled by writing 110b to Reg. 1Ch first. This register is reset at a AVDD27-POR.		
Bit	Bit Name	Default	Access	Bit Description
7	PWM_INVERT	0	R/W	PWM output polarity <b>0: not inverted</b> 1: inverted
6:0	PWM_CYCLE<6:0>	0000000	R/W	Sets the PWM duty cycle <b>0: no pulses</b> 1-127: duty cycle = PWM_CYCLE * 0,39%

Table 74. PLL Register

Name		Base		Default
PLL		2-wire serial		00h
Offset: 1Ah-7		PLL Register		
		This is an extended register and needs to be enabled by writing 111b to Reg. 1Ch first. This register is reset at a AVDD27-POR.		
Bit	Bit Name	Default	Access	Bit Description
7:4	OSR<3:0>	0000	R/W	Sets the oversampling rate when using the internal PLL <b>0x0: 128</b> 0x1-0xF: n/a
3:2	VCO_MODE<1:0>	00	R/W	Selects the speed of the PLL VCO according to the audio sampling frequency. <b>00: normal: 24-48kHz</b> 01: low: 8-23kHz 10: high: 49-96kHz 11: n/a
1:0	PLL_MODE<1:0>	00	R/W	Selects the PLL mode and master clock frequency source <b>00: automatic</b> turns PLL on, PLL clock is used as master clock if freq(LRCK) >8kHz and freq(MCLK)<32*freq(LRCK) 01: ON; turns PLL on, PLL clock is used as master clock 10: OFF; turns the PLL off, MCLK is used as master clock 11: auto_inv; like automatic but with inverted clock

Table 75. DCDC15 Register

Name		Base		Default
DCDC15		2-wire serial		00h
Offset: 1Bh-1		DCDC15 Register		
		This is an extended register and needs to be enabled by writing 001b to Reg. 1Ch first. This register is reset at a AVDD27-POR.		
Bit	Bit Name	Default	Access	Bit Description
7	DIM_UP_XDOWN	0	R/W	<b>0: disables the step-up converter and dims it down</b> 1: enables the step-up converter and dims it up
6:5	DIM_RATE<1:0>	00	R/W	Selects the dimming speed when enabling or disabling the DCDC15 <b>00: 0ms</b> 01: 300ms 10: 600ms 11: 1200ms
4	VFB_ON	0	R/W	<b>0: current feedback selected via ISINK1 and ISINK2</b> 1: voltage feedback selected, ISINK1 is sinking 50uA to define the voltage via an external zener diode
3	ExtDim_ON	0	R/W	<b>0: selects internal clock for dimming</b> 1: selects external clock for dimming
2:0	-	000	n/a	

Table 76. ISINK1 Register

Name		Base		Default
ISINK1		2-wire serial		00h
Offset: 1Bh-2		ISINK1 Register		
		This is an extended register and needs to be enabled by writing 010b to Reg. 1Ch first. This register is reset at a AVDD27-POR.		
Bit	Bit Name	Default	Access	Bit Description
7:3	I_SINK1<4:0>	00000	R/W	sets the current into current sink 1in 1.2mA steps <b>0: OFF, current sink 1 disabled</b> 1-31 1.2mA * I_SINK1 -> (1.2mA...37.2mA)
2:0	-	000	n/a	

Table 77. ISINK2 Register

Name		Base		Default
ISINK2		2-wire serial		00h
Offset: 1Bh-3		ISINK2 Register		
		This is an extended register and needs to be enabled by writing 011b to Reg. 1Ch first. This register is reset at a AVDD27-POR.		
Bit	Bit Name	Default	Access	Bit Description
7:3	I_SINK2<4:0>	00000	R/W	sets the current into current sink 2in 1.2mA steps <b>0: OFF, current sink 2 disabled</b> 1-31 1.2mA * I_SINK2 -> (1.2mA...37.2mA)
2:0	-	000	n/a	

Table 78. PMU\_Enable Register

Name		Base		Default
PMU_Enable		2-wire serial		00h
Offset: 1Ch-2		PMU_Enable Register		
		Selects the extended register on address 17h to 1Bh and enables writing to these PMU register. It also sets the ADC10 multiplexer to measure various regulator voltages This register is reset at a AVDD27-POR.		
Bit	Bit Name	Default	Access	Bit Description
7:4	DC_TEST_MUX <3:0>	0000	R/W	Allows multiplexing internal and external supply voltages to one DC test node which can be further multiplexed to the ADC10. The accuracy is 5mV/LSB (see reg. 2Eh) <b>0x0: open</b> 0x1: AVDD27 0x2: AVDD17 0x3: PVDD1 0x4: PVDD2 0x5: CVDD1 0x6: CVDD2 0x7: RVDD 0x8: FVDD 0x9: PWGD 0xA-0xF: n/a
3	PMU_GATE	000	R/W	Enables all settings made in registers 17h to 1Bh at once. If this bit is set, changes are activated as soon as they are written to the related register. <b>0: no change</b> 1: change at once
2:0	PMU_WR_ENABLE <2:0>	000	R/W	Selects extended registers 17h to 1Bh for the next write <b>0: no register selected</b> 1: 17h-1 to 1Bh-1 selected 2: 17h-2 to 1Bh-2 selected ... 7: 17h-7 to 1Bh-7 selected

Table 79. SYSTEM Register

Name		Base		Default
SYSTEM		2-wire serial		41h
Offset: 20h		SYSTEM Register		
This register is reset at a AVDD27-POR.				
Bit	Bit Name	Default	Access	Bit Description
7:4	Design_Version<3:0>	0100	R	AFE number to identify the design version 0100: for chip version 3v0
3	HB_WD_ON	0	R/W	Heartbeat (HBT) Watchdog The watchdog counter will be reset by a rising edge at the HBT input pin which has to occur at least every 500ms. If the watchdog counter is not reset, the AFE will be powered down. <b>0: HBT watchdog is disabled</b> 1: HBT watchdog is enabled
2	JTEMP_OFF	0	R/W	Junction temperature supervision (level can be set in register 21h) <b>0: temperature supervision enabled</b> 1: temperature supervision disabled
1	I2C_WD_ON	0	R/W	2-wire serial interface watchdog To reset the watchdog counter a 2-wire serial read operation has to be performed at least every 500ms. If the watchdog counter is not reset, the AFE will be powered down. <b>0: watchdog is disabled</b> 1: watchdog is enabled
0	PWR_HOLD	0	R/W	<b>0: power up hold is cleared and AFE will power down</b> 1: is automatically set to on after power on

Table 80. SUPERVISOR Register

Name		Base		Default																					
SUPERVISOR		2-wire serial		00h																					
Offset: 21h		SUPERVISOR Register																							
This register is reset at a AVDD27-POR.																									
Bit	Bit Name	Default	Access	Bit Description																					
7	SD_TIME	0100	R/W	Sets the emergency shut-down time invoked by PWRUP. <b>0: 5.4sec</b> 1: 10.9sec																					
6	BVDDlow_SD_OFF	0	R/W	<b>0: BVDDlow shut down enabled</b> 1: BVDDlow shut down disabled																					
5	-	0	n/a																						
4:0	JTEMP_SUP<4:0>	0	R/W	Sets the threshold for junction temperature emergency shutdown and junction temperature interrupt Invoke shutdown at: JTemp_SD=140-JTEMP_Sup*5°C Invoke interrupt at: JTemp_IRQ=120-JTEMP_Sup*5°C <table border="1" style="margin-left: 20px;"> <thead> <tr> <th>JT_Sup</th> <th>IRQ</th> <th>Shutdown</th> </tr> </thead> <tbody> <tr> <td>00000</td> <td>120°C</td> <td>140°C</td> </tr> <tr> <td>00001</td> <td>115°C</td> <td>135°C</td> </tr> <tr> <td>.</td> <td>.</td> <td>.</td> </tr> <tr> <td>.</td> <td>.</td> <td>.</td> </tr> <tr> <td>11110</td> <td>-30°C</td> <td>-10°C</td> </tr> <tr> <td>11111</td> <td>-35°C</td> <td>-15°C</td> </tr> </tbody> </table>	JT_Sup	IRQ	Shutdown	00000	120°C	140°C	00001	115°C	135°C	.	.	.	.	.	.	11110	-30°C	-10°C	11111	-35°C	-15°C
JT_Sup	IRQ	Shutdown																							
00000	120°C	140°C																							
00001	115°C	135°C																							
.	.	.																							
.	.	.																							
11110	-30°C	-10°C																							
11111	-35°C	-15°C																							

Table 81. RAM &amp; WakeUp Register

Name		Base		Default
RAM & WakeUp		2-wire serial		00h
Offset: 22h		RAM & WakeUp Register		
		Sets and enables the RTC wake-up counter and programs the 128bit SRAM. 3 bytes need to be written in a sequence to set the counter. The MSB of the 3 <sup>rd</sup> byte enables the wake-up counter. Byte 4 ...19 will program the static 128bit SRAM which is supplied by RVDD. This register keeps its content during normal shut-down and is only reset at a RVDD-POR.		
Bit	Byte Name	Default	Access	Bit Description
7:0	WAKE_UP_BYTE_0 (1 <sup>st</sup> write to 0x19 is byte 0)	00h	R/W	0000 0001b: 1sec 0000 0010b: 2sec 0000 0100b: 4sec 0000 1000b: 8sec 0001 0000b: 16sec 0010 0000b: 32sec 0100 0000b: 64sec 1000 0000b: 128sec
7:0	WAKE_UP_BYTE_1 (2 <sup>nd</sup> write to 0x19 is byte 1)	00h	R/W	0000 0001b: 256sec 0000 0010b: 512sec 0000 0100b: 1 024sec 0000 1000b: 2 048sec 0001 0000b: 4 096sec 0010 0000b: 8 192sec 0100 0000b: 16 384sec 1000 0000b: 32 768sec
7:0	WAKE_UP_BYTE_2 (3 <sup>rd</sup> write to 0x19 is byte 2)	00h	n/a	000 0001b: 65 536sec 000 0010b: 131 072sec 000 0100b: 262 144sec 000 1000b: 524 288sec 001 0000b: 1 048 576sec 010 0000b: 2 097 152sec 100 0000b: 4 194 304sec 0xxx xxxxxb = wake-up disabled 1xxx xxxxxb = wake-up enabled
7:0	SRAM_128<0:15> (4 <sup>th</sup> ... 19 <sup>th</sup> write to 0x22 programs the 128bit static SRAM)	00h	R/W	xxxx xxxxb = byte 0 : xxxx xxxxb = byte 15

Table 82. First Interrupt Register

Name		Base		Default
IRQENRD_0		2-wire serial		00h
Offset: 23h		<b>First Interrupt Register</b>		
		Please be aware that writing to this register will enable/disable the corresponding interrupts, while reading gets the actual interrupt status and will clear the register at the same time. It is not possible to read back the interrupt enable/disable settings. This register is reset at a AVDD27-POR.		
Bit	Bit Name	Default	Access	Bit Description
7	CVDD1_SD	0	W	Invokes shut-down of AFE when a –10% under-voltage spike at CVDD1 occurs <b>0: disable</b> 1: enable
	CVDD1_under	x	R	This bit is set when a –5% under-voltage at CVDD1 occurs
6	CVDD1_IRQ	0	W	Enables interrupt for over-voltage/under-voltage supervision of CVDD1 <b>0: disable</b> 1: enable
	CVDD1_over	x	R	This bit is set when a +8% over-voltage at CVDD1 occurs
5:4	-	00	n/a	
3	PVDD2_SD	0	W	Invokes shut-down of AFE when a –10% under-voltage spike at PVDD2 occurs <b>0: disable</b> 1: enable
	PVDD2_under	x	R	This bit is set when a –5% under-voltage at PVDD2 occurs
2	PVDD2_IRQ	0	W	Enables interrupt for over-voltage/under-voltage supervision of PVDD2 <b>0: disable</b> 1: enable
	PVDD2_over	x	R	This bit is set when a +5% over-voltage at PVDD2 occurs
1	PVDD1_SD	0	W	Invokes shut-down of AFE when a –10% under-voltage spike at PVDD1 occurs <b>0: disable</b> 1: enable
	PVDD1_under	x	R	This bit is set when a –5% under-voltage at PVDD1 occurs
0	PVDD1_IRQ	0	W	Enables interrupt for over-voltage/under-voltage supervision of PVDD1 <b>0: disable</b> 1: enable
	PVDD1_over	x	R	This bit is set when a +5% over-voltage at PVDD1 occurs

Table 83. Second Interrupt Register

Name		Base		Default
IRQENRD_1		2-wire serial		00h
Offset: 24h		<b>Second Interrupt Register</b>		
		Please be aware that writing to this register will enable/disable the corresponding interrupts, while reading gets the actual interrupt status and will clear the register at the same time. It is not possible to read back the interrupt enable/disable settings. This register is reset at a AVDD27-POR.		
Bit	Bit Name	Default	Access	Bit Description
7	PWRUP_IRQ	0	W	Enables interrupt which is invoked whenever a high signal at the PWRUP input pin occurs <b>0: disable</b> 1: enable
		x	R	This bit is set whenever a high level of min. BVDD/3 at the PWRUP input pin occurs (PWRUP pin is commonly connected to the power-up button)
6	WAKEUP_IRQ	0	W	Enables interrupt which is invoked whenever a wake-up from RTC wake-up counter occurs <b>0: disable</b> 1: enable
		x	R	This bit is set when a wake-up has been invoked by the RTC wake-up counter.
5	MCLK_IRQ	0	W	Enables interrupt which is invoked whenever a high signal at the MCLK input pin occurs <b>0: disable</b> 1: enable
		x	R	This bit is set whenever a high level of min. BVDD/3 at the MCLK input pin occurs (MCLK pin can be used as alternative power-up button)
4:2	-	0	n/a	
1	CVDD2_SD	0	W	Invokes shut-down of AFE when a -10% under-voltage spike at CVDD2 occurs <b>0: disable</b> 1: enable
	CVDD2_under	x	R	This bit is set when a -5% under-voltage at CVDD2 occurs
0	CVDD2_IRQ	0	W	Enables interrupt for over-voltage/under-voltage supervision of CVDD2 <b>0: disable</b> 1: enable
	CVDD2_over	x	R	This bit is set when a +8% over-voltage at CVDD2 occurs

Table 84. Thrid Interrupt Register

Name		Base		Default
IRQENRD_2		2-wire serial		00h
Offset: 25h		<b>Third Interrupt Register</b>		
		Please be aware that writing to this register will enable/disable the corresponding interrupts, while reading gets the actual interrupt status and will clear the register at the same time. It is not possible to read back the interrupt enable/disable settings. This register is reset at a AVDD27-POR.		
Bit	Bit Name	Default	Access	Bit Description
7	BATTEMP_IRQ	0	W	Battery over-temperature interrupt setting. <b>0: disable</b> 1: enable interrupt if battery temperature exceeds 45/55°C The interrupt must not be enabled if the charger block and battery temperature supervision is disabled
		x	R	Battery over-temperature interrupt reading <b>0: battery temperature below 45/55°C</b> 1: battery temperature was too high and the charger was turned off. The charger will be turned on again, when the temperature gets below 42/50°C
6	CHG_EOC	x	R	Battery end of charge interrupt reading <b>0: battery charging in progress</b> 1: charging is complete, charging current is below 10% of nominal current, turn off charger
5	CHG_CON	x	R	0: no charger input source connected 1: charger input source connected, also valid if charger is connected during wakeup
4	CHG_IRQ	0	W	Charger status change interrupt setting <b>0: disable</b> 1: enables an interrupt on a low to high or high to low change of CHGIN pin or on an EOC condition
	CHG_changed (status change)	x	R	Charger input status change interrupt reading 0: charger status not changed 1: charger status changed, check CHG_CON, CHG_EOC
3	USB_CON	0	n/a	0: no USB input connected 1: USB input connected, also valid if USB is connected during wakeup. The threshold can be set in the USB_UTIL register (1Ah)
2	USB_IRQ	0	W	USB input status change interrupt setting <b>0: disable</b> 1: enables an interrupt on a low to high or high to low change of VBUS pin. The threshold can be set in the USB_UTIL register (1Ah)
	USB_changed (status change)	x	R	USB input status change interrupt reading 0: USB input status not changed 1: USB input status changed, check USB_CON

Table 84. Thrid Interrupt Register

Name		Base		Default
IRQENRD_2		2-wire serial		00h
Offset: 25h		Third Interrupt Register		
		Please be aware that writing to this register will enable/disable the corresponding interrupts, while reading gets the actual interrupt status and will clear the register at the same time. It is not possible to read back the interrupt enable/disable settings. This register is reset at a AVDD27-POR.		
Bit	Bit Name	Default	Access	Bit Description
1	RTC_WD (level)	0	W	Real time clock watchdog interrupt setting <b>0: disable</b> 1: enable
		x	R	Real time clock watchdog interrupt reading <b>0: RTC o.k.</b> 1: RTC oscillator was stopped, RTC not longer valid The interrupt gets set in hibernation or during power-up even if the interrupt is not enabled thus allowing to recognise a change of the battery connected to BVDDR during hibernation or shutdown. For a valid reading, the interrupt has to be enabled first.
0	BVDD_LOW (level)	0	W	BVDD under-voltage supervisor interrupt setting <b>0: disable</b> 1: enable
		x	R	BVDD supervisor interrupt reading <b>0: BVDD is above brown out level</b> 1: BVDD has reached brown out level The threshold can be set in the SUPERVISOR register (21h)

Table 85. Fourth Interrupt Register

Name		Base		Default
IRQENRD_3		2-wire serial		00h
Offset: 26h		Fourth Interrupt Register		
		Please be aware that writing to this register will enable/disable the corresponding interrupts, while reading gets the actual interrupt status and will clear the register at the same time. It is not possible to read back the interrupt enable/disable settings. This register is reset at a AVDD27-POR.		
Bit	Bit Name	Default	Access	Bit Description
7	JTEMP_HIGH (level)	0	W	Supervisor junction over-temperature interrupt setting <b>0: disable</b> 1: enable
		x	R	Supervisor junction over-temperature interrupt reading 0: chip temperature below threshold 1: chip temperature has reached the threshold The threshold can be set in the SUPERVISOR register (21h)
6	-	0	n/a	

Table 85. Fourth Interrupt Register

Name		Base		Default
IRQENRD_3		2-wire serial		00h
Offset: 26h		<b>Fourth Interrupt Register</b>		
		Please be aware that writing to this register will enable/disable the corresponding interrupts, while reading gets the actual interrupt status and will clear the register at the same time. It is not possible to read back the interrupt enable/disable settings. This register is reset at a AVDD27-POR.		
Bit	Bit Name	Default	Access	Bit Description
5	HP_OVC (level)	0	W	Headphone over-current interrupt setting <b>0: disable</b> 1: enable The interrupt must not be enabled if the headphone block is disabled
		x	R	Headphone over-current interrupt reading 0: no over-current detected 1: headphone over-current detected, headphone amplifier was shut down. The current thresholds are 150mA at HPR / HPL pin or 300mA at HPCM pin.
4	I2S_status	x	R	0: no LRCK on I2S interface detected 1: LRCK on I2S interface present
3	I2S_IRQ	0	W	I2S input status change interrupt setting <b>0: disable</b> 1: enable
	I2S_changed (status change)	x	R	I2S input status change interrupt reading 0: I2S input status not changed 1: I2S input status changed, check I2S_status
2	VOXM_IRQ	0	W	Enables interrupt which is invoked by reaching a voltage threshold at the MIC input (voice activation) <b>0: disable</b> 1: enable
		x	R	This bit is set when a voltage threshold of 5mVRMS (unfiltered) at the MIC has been reached (voice activation)
1	MIC_CON (level)	0	W	Microphone connect detection interrupt setting <b>0: disable</b> 1: enable
		x	R	Microphone connect detection interrupt reading 0: no microphone connected to MIC input 1: microphone connected at MIC input. This interrupt is only invoked when the microphone stage is powered down. The IRQ will be released after enabling the microphone stage. Detecting a microphone during operation has to be done by measuring the supply current
0	HPH_CON (level)	0	W	Headphone connect detection interrupt setting <b>0: disable</b> 1: enable
		x	R	Headphone connect detection interrupt reading 0: no headphone connected 1: headphone connected This interrupt is only invoked when the headphone stage is powered down. The IRQ will be released after enabling the headphone stage. Detecting a headphone during operation is not possible.

Table 86. Fifth Interrupt Register

Name		Base		Default
IRQENRD_4		2-wire serial		00h
Offset: 27h		<b>Fifth Interrupt Register</b>		
		Please be aware that writing to this register will enable/disable the corresponding interrupts, while reading gets the actual interrupt status and will clear the register at the same time. It is not possible to read back the interrupt enable/disable settings. This register is reset at a AVDD27-POR.		
Bit	Bit Name	Default	Access	Bit Description
7:6	T_DEB<1:0>	00	R/W	Sets the USB and Charger connect de-bounce time: <b>00: 512ms</b> 01: 256ms 10: 128ms 11: 0ms
5	AVDD27_IRQ	0	W	Enables interrupt for under-voltage supervision of AVDD27 <b>0: disable</b> 1: enable
	AVDD27_under	x	R	This bit is set when a -5% under-voltage at AVDD27 occurs
4	DCDC15_IRQ	0	W	Enables interrupt for over-voltage supervision of SW15 <b>0: disable</b> 1: enable
	DCDC15_over	x	R	This bit is set when SW15 exceeds 15V.
3	-	0	n/a	
2	REM_DET (edge)	0	W	Microphone remote key press detection interrupt setting <b>0: disable</b> 1: enable
		x	R	Microphone remote key press detection interrupt reading 0: no key press detected 1: Microphone supply current got increased, remote key press detected -> measure MICS supply current
1	RTC_UPDATE (edge)	0	W	RTC timer interrupt setting <b>0: disable</b> 1: enable
		x	R	RTC timer interrupt reading 0: no RTC interrupt occurred 1: RTC timer interrupt occurred. Selecting minute or second interrupt can be done via RTCT register (29h)
0	ADC_EOC (edge)	0	W	ADC end of conversion interrupt setting <b>0: disable</b> 1: enable
		x	R	ADC end of conversion interrupt reading 0: ADC conversion not finished 1: ADC conversion finished. Read out ADC_0 and ADC_1 register to get the result (2Eh & 2Fh)

Table 87. RTC\_Cntr Register

Name		Base		Default
RTC_Cntr		2-wire serial		03h
Offset: 28h		RTC Control Register		
This register is reset at a RVDD-POR.				
Bit	Bit Name	Default	Access	Bit Description
7:4	Free_Bits<3:0>	0000	R/W	Free Bits to be used for application purpose
3:2	-	00	n/a	
1	RTC_ON	1	R/W	RTC counter clock control: 0: Disable clock for RTC counter <b>1: Enables clock for RTC counter</b>
0	OSC_ON	1	RW	RTC oscillator control: 0: Disable RTC oscillator <b>1: Enable RTC oscillator</b>

Table 88. RTC\_Time Register

Name		Base		Default
RTC_time		2-wire serial		03h
Offset: 29h		RTC Timing Register		
This register is reset at a RVDD-POR.				
Bit	Bit Name	Default	Access	Bit Description
7	IRQ_MIN	0	R/W	<b>0: generates an interrupt every second</b> 1: generates an interrupt every minute The interrupt has to be enable in IRQENRD_4 (27h)
6:0	TRTC<6:0>	1000000	R/W	These bits are used to correct the inaccuracy of the used 32kHz crystal.  Trimming register for RTC, 128 steps @ 7.6ppm 000000: 1 (7.6ppm) 000001: 2 (15.2ppm) ... <b>100000: 64 (488ppm)</b> ... 111110: 126 (960.8ppm) 111111: 127 (968.4ppm)

Table 89. RTC\_0 to RTC\_3 Register

Name		Base		Default
RTC_0 to RTC_3		2-wire serial		03h
Offset: 2Ah to 2Dh		RTC Counter Seconds Register		
This register is reset at a RVDD-POR.				
Adr.	Byte Name	Default	Access	Bit Description
2Ah	RTC_0	00h	R/W	QRTC<7:0>; RTC seconds bits 0 to 7
2Bh	RTC_1	00h	R/W	QRTC<15:8>; RTC seconds bits 8 to 15
2Ch	RTC_2	00h	R/W	QRTC<23:9>; RTC seconds bits 9 to 23
2Dh	RTC_3	00h	R/W	QRTC<31:24>; RTC seconds bits 24 to 31

Table 90. ADC10\_0 Register

Name		Base		Default
ADC10_0		2-wire serial		0000 00xxb
Offset: 2Eh		First 10-bit ADC Register		
		Writing to this register will start the measurement of the selected source. This register is reset at a AVDD27-POR, exception are bit 0 and 1		
Bit	Bit Name	Default	Access	Bit Description
7:4	ADC10_MUX<3:0>	0000	R/W	Selects ADC input source <b>0000: BVDD</b> 0001: BVDDR 0010: CHGIN 0011: CHGOUT 0100: VBUS 0101: defined by DC_TEST in register 0x1C 0110: BATTEMP 0111: reserved 1000: MICS 1001: reserved 1010: I_MICS 1011: reserved 1100: VBE_1uA 1101: VBE_2uA 1110: I_CHGact 1111: I_CHGref
3:2	-	00	n/a	
1:0	ADC10<9:8>	xx	R	ADC result bit 9 to 8

Table 91. ADC10\_1 Register

Name		Base		Default
ADC10_1		2-wire serial		xxh
Offset: 2Fh		Second 10-bit ADC Register		
		This register is reset at a AVDD27-POR.		
Bit	Bit Name	Default	Access	Bit Description
7:0	ADC10<7:0>	00h	R	ADC results bits 7 to 0

Table 92. UID\_0 to UID\_7 Register

Name		Base		Default
UID_0 to UID7		2-wire serial		n/a
Offset: 38h to 3Fh		UNIQUE ID Register		
		This is a read only register and gets not reset.		
Adr.	Byte Name	Default	Access	Bit Description
38h	UID_0	n/a	R	Unique ID byte 0
39h	UID_1	n/a	R	Unique ID byte 1
3Ah	UID_2	n/a	R	Unique ID byte 2
3Bh	UID_3	n/a	R	Unique ID byte 3
3Ch	UID_4	n/a	R	Unique ID byte 4
3Dh	UID_5	n/a	R	Unique ID byte 5
3Eh	UID_6	n/a	R	Unique ID byte 6
3Fh	UID_7	n/a	R	Unique ID byte 7



### 13 Package Drawings and Markings

Figure 31. CTBGA67 Marking



Table 93. Package Code AYWWZZZ

A	Y	WW	ZZZ
B ... for Green	year	working week assembly / packaging	free choice

Figure 32. CTBGA68 6x6 0.5mm pitch

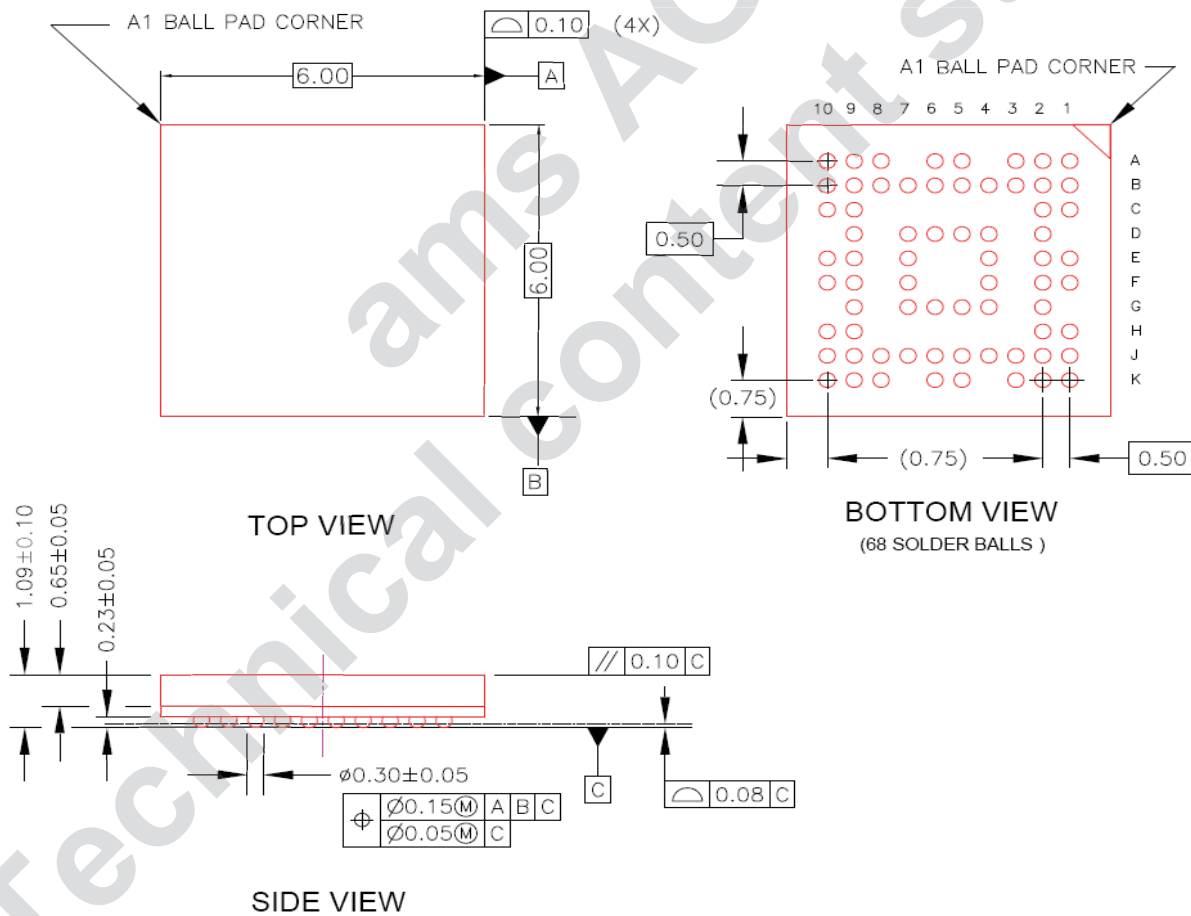

NOTE  
1. GENERAL TOLERANCE : ± 0.10

## 14 Ordering Information

Table 94. Ordering Information

Model	Description	Delivery Form	Package
AS3543-ECTP	High End Stereo Audio Codec with System PMU	Tape & Reel dry pack	68-ball CTBGA 0.5mm pitch (6.0mm x 6.0mm)

**Note:** E Temperature Range: -20°C - 85°C  
CT Package: CTBGA  
P Delivery Form: Tape & Reel dry pack

ams AG  
Technical content still valid

## Copyrights

Copyright © 1997-2011, austriamicrosystems AG, Schloss Premstaetten, 8141 Unterpremstaetten, Austria-Europe. Trademarks Registered ®. All rights reserved. The material herein may not be reproduced, adapted, merged, translated, stored, or used without the prior written consent of the copyright owner.

All products and companies mentioned are trademarks or registered trademarks of their respective companies.

## Disclaimer

Devices sold by austriamicrosystems AG are covered by the warranty and patent indemnification provisions appearing in its Term of Sale. austriamicrosystems AG makes no warranty, express, statutory, implied, or by description regarding the information set forth herein or regarding the freedom of the described devices from patent infringement. austriamicrosystems AG reserves the right to change specifications and prices at any time and without notice. Therefore, prior to designing this product into a system, it is necessary to check with austriamicrosystems AG for current information. This product is intended for use in normal commercial applications. Applications requiring extended temperature range, unusual environmental requirements, or high reliability applications, such as military, medical life-support or life-sustaining equipment are specifically not recommended without additional processing by austriamicrosystems AG for each application. For shipments of less than 100 parts the manufacturing flow might show deviations from the standard production flow, such as test flow or test location.

The information furnished here by austriamicrosystems AG is believed to be correct and accurate. However, austriamicrosystems AG shall not be liable to recipient or any third party for any damages, including but not limited to personal injury, property damage, loss of profits, loss of use, interruption of business or indirect, special, incidental or consequential damages, of any kind, in connection with or arising out of the furnishing, performance or use of the technical data herein. No obligation or liability to recipient or any third party shall arise or flow out of austriamicrosystems AG rendering of technical or other services.



## Contact Information

### Headquarters

austriamicrosystems AG  
A-8141 Schloss Premstaetten, Austria

Tel: +43 (0) 3136 500 0  
Fax: +43 (0) 3136 525 01

For Sales Offices, Distributors and Representatives, please visit:

<http://www.austriamicrosystems.com/contact>

## Looking for pricing, stock, or lifecycle information?

Click below to explore more details on WIN SOURCE:

- ⊖ [View AS3543-ECTP on WIN SOURCE](#)
- ⊖ [OSRAM Opto Semiconductors Inc. Information](#)

## Optimize Your Supply Chain with WIN SOURCE Solutions

- ✓ Global Sourcing Solution
- ✓ Obsolete Management
- ✓ Cost Control Management
- ✓ Shortage Management
- ✓ Alternative Solution
- ✓ Excess Inventory Management