



**THE DATASHEET OF
ADG1209YRUZ**



FEATURES

- <1 pC charge injection over full signal range
- 1 pF off capacitance
- 33 V supply range
- 120 Ω on resistance
- Fully specified at ± 15 V/+12 V
- 3 V logic compatible inputs
- Rail-to-rail operation
- Break-before-make switching action
- Available in a 16-lead TSSOP, a 16-lead LFCSP, and a 16-lead SOIC
- Typical power consumption < 0.03 μ W

APPLICATIONS

- Audio and video routing
- Automatic test equipment
- Data-acquisition systems
- Battery-powered systems
- Sample-and-hold systems
- Communication systems

GENERAL DESCRIPTION

The **ADG1208** and **ADG1209** are monolithic, *i*CMOS[®] analog multiplexers comprising eight single channels and four differential channels, respectively. The **ADG1208** switches one of eight inputs to a common output as determined by the 3-bit binary address lines A0, A1, and A2. The **ADG1209** switches one of four differential inputs to a common differential output as determined by the 2-bit binary address lines A0 and A1. An EN input on both devices enable or disable the device. When disabled, all channels are switched off. When on, each channel conducts equally well in both directions and has an input signal range that extends to the supplies.

The industrial CMOS (*i*CMOS) modular manufacturing process combines high voltage complementary metal-oxide semiconductor (CMOS) and bipolar technologies. It enables the development of a wide range of high performance analog ICs capable of 33 V operation in a footprint that no other generation of high voltage devices has been able to achieve. Unlike analog ICs using conventional CMOS processes, *i*CMOS components can tolerate high supply voltages while providing increased performance, dramatically lower power consumption, and reduced package size.

FUNCTIONAL BLOCK DIAGRAMS

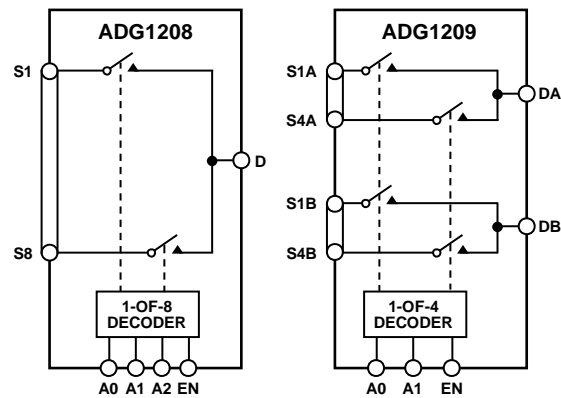

Figure 1.

The ultralow capacitance and exceptionally low charge injection of these multiplexers make them ideal solutions for data acquisition and sample-and-hold applications, where low glitch and fast settling are required. Figure 2 shows that there is minimum charge injection over the entire signal range of the device. *i*CMOS construction also ensures ultralow power dissipation, making the devices ideally suited for portable and battery-powered instruments.

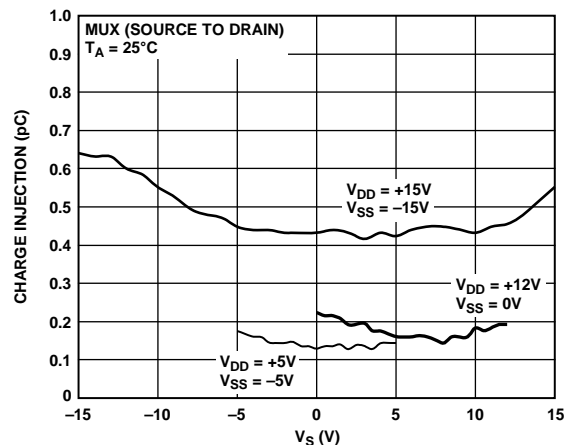

Figure 2. Source to Drain Charge Injection vs. Source Voltage

Rev. E

[Document Feedback](#)

Information furnished by Analog Devices is believed to be accurate and reliable. However, no responsibility is assumed by Analog Devices for its use, nor for any infringements of patents or other rights of third parties that may result from its use. Specifications subject to change without notice. No license is granted by implication or otherwise under any patent or patent rights of Analog Devices. Trademarks and registered trademarks are the property of their respective owners.

TABLE OF CONTENTS

Features	1	ESD Caution.....	7
Applications.....	1	Pin Configurations and Function Descriptions	8
Functional Block Diagrams.....	1	Typical Performance Characteristics	12
General Description	1	Terminology	16
Revision History	2	Test Circuits.....	17
Specifications.....	3	Outline Dimensions	20
Dual Supply	3	Ordering Guide	21
Single Supply	5		
Absolute Maximum Ratings.....	7		

REVISION HISTORY

6/2016—Rev. D to Rev. E

Changes to Analog Inputs Parameter, Table 3	7
Added Digital Inputs Parameter, Table 3	7
Moved Figure 7	10
Change to Table 7	10
Deleted Table 8; Renumbered Sequentially	11
Updated Outline Dimensions	20
Changes to Ordering Guide	21

3/2016—Rev. C to Rev. D

Changes to Table 4 Title.....	8
Changes to Table 5 Title.....	9
Changes to Table 7 Title.....	10
Changes to Figure 7.....	11
Added Table 8; Renumbered Sequentially	11
Changes to Table 9 Title.....	12

8/2015—Rev. B to Rev. C

Changes to Features Section.....	1
Added Figure 4; Renumbered Sequentially	8
Changes to Table 4.....	8
Changes to Figure 5.....	9
Added Table 5; Renumbered Sequentially	9
Added Figure 7	10
Changes to Table 7	10
Changes to Figure 8.....	11
Added Table 8.....	11
Updated Outline Dimensions	19
Changes to Ordering Guide	20

1/2009—Rev. A to Rev. B

Change to I _{DD} Parameter, Table 1	4
Change to I _{DD} Parameter, Table 2	6

4/2007—Rev. 0 to Rev. A

Added 16-lead SOIC	Universal
Changes to Table 1.....	3
Changes to Table 2.....	5
Changes to Figure 10 and Figure 11.....	10
Updated Outline Dimensions	17
Changes to Ordering Guide	18

4/2006—Revision 0: Initial Version

SPECIFICATIONS

DUAL SUPPLY

$V_{DD} = +15\text{ V} \pm 10\%$, $V_{SS} = -15\text{ V} \pm 10\%$, $GND = 0\text{ V}$, unless otherwise noted. Temperature range is as follows: Y version: -40°C to $+125^{\circ}\text{C}$.

Table 1.

Parameter	+25°C	-40°C to +85°C	-40°C to +125°C	Unit	Test Conditions/Comments
ANALOG SWITCH					
Analog Signal Range			V_{SS} to V_{DD}	V	
On Resistance, R_{ON}	120			Ω typ	$V_S = \pm 10\text{ V}$, $I_S = -1\text{ mA}$, see Figure 31
	200	240	270	Ω max	$V_{DD} = +13.5\text{ V}$, $V_{SS} = -13.5\text{ V}$
On-Resistance Match Between Channels, ΔR_{ON}	3.5			Ω typ	$V_S = \pm 10\text{ V}$, $I_S = -1\text{ mA}$
	6	10	12	Ω max	
On-Resistance Flatness, R_{FLAT} (On)	20			Ω typ	$V_S = -5\text{ V}/0\text{ V}/+5\text{ V}$, $I_S = -1\text{ mA}$
	64	76	83	Ω max	
LEAKAGE CURRENTS					
Source Off Leakage, I_S (Off)	± 0.003			nA typ	$V_D = \pm 10\text{ V}$, $V_S = -10\text{ V}$, see Figure 32
	± 0.1	± 0.6	± 1	nA max	
Drain Off Leakage, I_D (Off)	± 0.003			nA typ	$V_S = 1\text{ V}/10\text{ V}$, $V_D = 10\text{ V}/1\text{ V}$, see Figure 32
	± 0.1	± 0.6	± 1	nA max	
Channel On Leakage, I_D , I_S (On)	± 0.02			nA typ	$V_S = V_D = \pm 10\text{ V}$, see Figure 33
	± 0.2	± 0.6	± 1	nA max	
	± 0.2	± 0.6	± 1	nA max	
DIGITAL INPUTS					
Input High Voltage, V_{INH}			2.0	V min	
Input Low Voltage, V_{INL}			0.8	V max	
Input Current, I_{INL} or I_{INH}	± 0.005			μA max	$V_{IN} = V_{INL}$ or V_{INH}
			± 0.1	μA max	
Digital Input Capacitance, C_{IN}	2			pF typ	
DYNAMIC CHARACTERISTICS¹					
Transition Time, $t_{TRANSITION}$	80			ns typ	$R_L = 300\ \Omega$, $C_L = 35\text{ pF}$
	130	165	185	ns max	$V_S = 10\text{ V}$, see Figure 34
t_{ON} (EN)	75			ns typ	$R_L = 300\ \Omega$, $C_L = 35\text{ pF}$
	95	105	115	ns max	$V_S = 10\text{ V}$, see Figure 36
t_{OFF} (EN)	83			ns typ	$R_L = 300\ \Omega$, $C_L = 35\text{ pF}$
	100	125	140	ns max	$V_S = 10\text{ V}$, see Figure 36
Break-Before-Make Time Delay, t_{BBM}	25			ns typ	$R_L = 300\ \Omega$, $C_L = 35\text{ pF}$
			10	ns min	$V_{S1} = V_{S2} = 10\text{ V}$, see Figure 35
Charge Injection	0.4			pC typ	$V_S = 0\text{ V}$, $R_S = 0\ \Omega$, $C_L = 1\text{ nF}$, see Figure 37
Off Isolation	-85			dB typ	$R_L = 50\ \Omega$, $C_L = 5\text{ pF}$, $f = 1\text{ MHz}$, see Figure 38
Channel to Channel Crosstalk	-85			dB typ	$R_L = 50\ \Omega$, $C_L = 5\text{ pF}$, $f = 1\text{ MHz}$, see Figure 40
Total Harmonic Distortion Plus Noise	0.15			% typ	$R_L = 10\text{ k}\Omega$, 5 V rms , $f = 20\text{ Hz}$ to 20 kHz , see Figure 41
-3 dB Bandwidth	550			MHz typ	$R_L = 50\ \Omega$, $C_L = 5\text{ pF}$, see Figure 39
C_S (Off)	1			pF typ	$f = 1\text{ MHz}$, $V_S = 0\text{ V}$
	1.5			pF max	$f = 1\text{ MHz}$, $V_S = 0\text{ V}$
C_D (Off), ADG1208	6			pF typ	$f = 1\text{ MHz}$, $V_S = 0\text{ V}$
	7			pF max	$f = 1\text{ MHz}$, $V_S = 0\text{ V}$
C_D (Off), ADG1209	3.5			pF typ	$f = 1\text{ MHz}$, $V_S = 0\text{ V}$
	4.5			pF max	$f = 1\text{ MHz}$, $V_S = 0\text{ V}$

Parameter	+25°C	-40°C to		Unit	Test Conditions/Comments
		+85°C	+125°C		
C_D, C_S (On), ADG1208	7			pF typ	$f = 1 \text{ MHz}, V_S = 0 \text{ V}$
	8			pF max	$f = 1 \text{ MHz}, V_S = 0 \text{ V}$
C_D, C_S (On), ADG1209	5			pF typ	$f = 1 \text{ MHz}, V_S = 0 \text{ V}$
	6			pF max	$f = 1 \text{ MHz}, V_S = 0 \text{ V}$
POWER REQUIREMENTS					
I_{DD}	0.002		1.0	$\mu\text{A typ}$ $\mu\text{A max}$	$V_{DD} = +16.5 \text{ V}, V_{SS} = -16.5 \text{ V}$ Digital inputs = 0 V or V_{DD}
I_{DD}	220		380	$\mu\text{A typ}$ $\mu\text{A max}$	Digital inputs = 5 V
I_{SS}	0.002		1.0	$\mu\text{A typ}$ $\mu\text{A max}$	Digital inputs = 0 V or V_{DD}
I_{SS}	0.002		1.0	$\mu\text{A typ}$ $\mu\text{A max}$	Digital inputs = 5 V
V_{DD}/V_{SS}			$\pm 5/\pm 16.5$	V min/max	$ V_{DD} = V_{SS} $

¹ Guaranteed by design, not subject to production test.

SINGLE SUPPLY

$V_{DD} = 12\text{ V} \pm 10\%$, $V_{SS} = 0\text{ V}$, $GND = 0\text{ V}$, unless otherwise noted. Temperature range is as follows: Y version: -40°C to $+125^{\circ}\text{C}$.

Table 2.

Parameter	+25°C	-40°C to +85°C	-40°C to +125°C	Unit	Test Conditions/Comments
ANALOG SWITCH					
Analog Signal Range			0 to V_{DD}	V	
On Resistance, R_{ON}	300			Ω typ	$V_S = 0\text{ V}$ to 10 V , $I_S = -1\text{ mA}$, see Figure 31
	475	567	625	Ω max	$V_{DD} = 10.8\text{ V}$, $V_{SS} = 0\text{ V}$
On-Resistance Match Between Channels, ΔR_{ON}	5			Ω typ	$V_S = 0\text{ V}$ to 10 V , $I_S = -1\text{ mA}$
On-Resistance Flatness, R_{FLAT} (On)	16	26	27	Ω max	
	60			Ω typ	$V_S = 3\text{ V}/6\text{ V}/9\text{ V}$, $I_S = -1\text{ mA}$
LEAKAGE CURRENTS					
Source Off Leakage, I_S (Off)	± 0.003			nA typ	$V_{DD} = 13.2\text{ V}$
	± 0.1	± 0.6	± 1	nA max	$V_S = 1\text{ V}/10\text{ V}$, $V_D = 10\text{ V}/1\text{ V}$, see Figure 32
Drain Off Leakage, I_D (Off)	± 0.003			nA typ	
	± 0.1	± 0.6	± 1	nA max	$V_S = 1\text{ V}/10\text{ V}$, $V_D = 10\text{ V}/1\text{ V}$, see Figure 32
Channel On Leakage I_D , I_S (On)	± 0.02			nA typ	
	± 0.2	± 0.6	± 1	nA max	$V_S = V_D = 1\text{ V}$ or 10 V , see Figure 33
	± 0.2	± 0.6	± 1	nA max	
DIGITAL INPUTS					
Input High Voltage, V_{INH}			2.0	V min	
Input Low Voltage, V_{INL}			0.8	V max	
Input Current, I_{INL} or I_{INH}	± 0.001			μA max	$V_{IN} = V_{INL}$ or V_{INH}
Digital Input Capacitance, C_{IN}	3			pF typ	
DYNAMIC CHARACTERISTICS¹					
Transition Time, $t_{TRANSITION}$	100			ns typ	$R_L = 300\ \Omega$, $C_L = 35\text{ pF}$
	170	210	235		$V_S = 8\text{ V}$, see Figure 34
t_{ON} (EN)	90			ns typ	$R_L = 300\ \Omega$, $C_L = 35\text{ pF}$
	110	140	160		$V_S = 8\text{ V}$, see Figure 36
t_{OFF} (EN)	105			ns typ	$R_L = 300\ \Omega$, $C_L = 35\text{ pF}$
	130	155	175		$V_S = 8\text{ V}$, see Figure 36
Break-Before-Make Time Delay, t_{BBM}	45			ns typ	$R_L = 300\ \Omega$, $C_L = 35\text{ pF}$
			20	ns min	$V_{S1} = V_{S2} = 8\text{ V}$, see Figure 35
Charge Injection	-0.2			pC typ	$V_S = 6\text{ V}$, $R_S = 0\ \Omega$, $C_L = 1\text{ nF}$, see Figure 37
Off Isolation	-85			dB typ	$R_L = 50\ \Omega$, $C_L = 5\text{ pF}$, $f = 1\text{ MHz}$, see Figure 38
Channel to Channel Crosstalk	-85			dB typ	$R_L = 50\ \Omega$, $C_L = 5\text{ pF}$, $f = 1\text{ MHz}$, see Figure 40
-3 dB Bandwidth	450			MHz typ	$R_L = 50\ \Omega$, $C_L = 5\text{ pF}$, see Figure 39
C_S (Off)	1.2			pF typ	$f = 1\text{ MHz}$, $V_S = 6\text{ V}$
	1.8			pF max	$f = 1\text{ MHz}$, $V_S = 6\text{ V}$
C_D (Off), ADG1208	7.5			pF typ	$f = 1\text{ MHz}$, $V_S = 6\text{ V}$
	9			pF max	$f = 1\text{ MHz}$, $V_S = 6\text{ V}$
C_D (Off), ADG1209	4.5			pF typ	$f = 1\text{ MHz}$, $V_S = 6\text{ V}$
	5.5			pF max	$f = 1\text{ MHz}$, $V_S = 6\text{ V}$
C_D , C_S (On), ADG1208	9			pF typ	$f = 1\text{ MHz}$, $V_S = 6\text{ V}$
	10.5			pF max	$f = 1\text{ MHz}$, $V_S = 6\text{ V}$
C_D , C_S (On), ADG1209	6			pF typ	$f = 1\text{ MHz}$, $V_S = 6\text{ V}$
	7.5			pF max	$f = 1\text{ MHz}$, $V_S = 6\text{ V}$

Parameter	+25°C	-40°C to +85°C	-40°C to +125°C	Unit	Test Conditions/Comments
POWER REQUIREMENTS					$V_{DD} = 13.2\text{ V}$
I_{DD}	0.002		1.0	$\mu\text{A typ}$ $\mu\text{A max}$	Digital inputs = 0 V or V_{DD}
I_{DD}	220		380	$\mu\text{A typ}$ $\mu\text{A max}$	Digital inputs = 5 V
V_{DD}			5/16.5	V min/max	$V_{SS} = 0\text{ V}$, GND = 0 V

¹ Guaranteed by design, not subject to production test.

ABSOLUTE MAXIMUM RATINGS

$T_A = 25^\circ\text{C}$, unless otherwise noted.

Table 3.

Parameter	Rating
V_{DD} to V_{SS}	35 V
V_{DD} to GND	-0.3 V to +25 V
V_{SS} to GND	+0.3 V to -25 V
Analog Inputs ¹	$V_{SS} - 0.3\text{ V}$ to $V_{DD} + 0.3\text{ V}$ or 30 mA (whichever occurs first)
Digital Inputs ¹	GND - 0.3 V to $V_{DD} + 0.3\text{ V}$ or 30 mA (whichever occurs first)
Continuous Current, S or D	30 mA
Peak Current, S or D (Pulsed at 1 ms, 10% Duty Cycle Maximum)	100 mA
Operating Temperature Range	
Industrial (Y Version)	-40°C to +125°C
Storage Temperature	-65°C to +150°C
Junction Temperature	150°C
θ_{JA} Thermal Impedance	
TSSOP	112°C/W
LFCSP	30.4°C/W
SOIC	77°C/W
Reflow Soldering Peak Temperature (Pb-Free)	260(+0/-5)°C

¹ Overvoltages at A, EN, S, or D are clamped by internal diodes. Current should be limited to the maximum ratings given.

Stresses at or above those listed under Absolute Maximum Ratings may cause permanent damage to the product. This is a stress rating only; functional operation of the product at these or any other conditions above those indicated in the operational section of this specification is not implied. Operation beyond the maximum operating conditions for extended periods may affect product reliability.

ESD CAUTION



ESD (electrostatic discharge) sensitive device. Charged devices and circuit boards can discharge without detection. Although this product features patented or proprietary protection circuitry, damage may occur on devices subjected to high energy ESD. Therefore, proper ESD precautions should be taken to avoid performance degradation or loss of functionality.

PIN CONFIGURATIONS AND FUNCTION DESCRIPTIONS

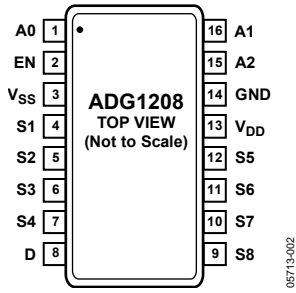

Figure 3. 16-Lead TSSOP Pin Configuration (ADG1208)

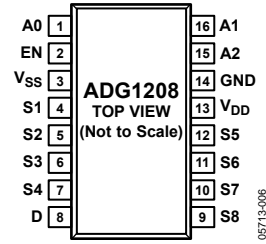
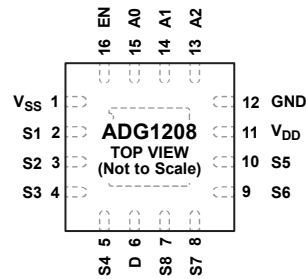

Figure 4. 16-Lead SOIC Pin Configuration (ADG1208)

Table 4. 16-Lead TSSOP and 16-Lead SOIC Pin Function Descriptions (ADG1208)

Pin No.	Mnemonic	Description
1	A0	Logic Control Input.
2	EN	Active High Digital Input. When low, the device is disabled and all switches are off. When high, Ax logic inputs determine on switches.
3	V _{SS}	Most Negative Power Supply Potential. In single-supply applications, it can be connected to ground.
4	S1	Source Terminal 1. Can be an input or an output.
5	S2	Source Terminal 2. Can be an input or an output.
6	S3	Source Terminal 3. Can be an input or an output.
7	S4	Source Terminal 4. Can be an input or an output.
8	D	Drain Terminal. Can be an input or an output.
9	S8	Source Terminal 8. Can be an input or an output.
10	S7	Source Terminal 7. Can be an input or an output.
11	S6	Source Terminal 6. Can be an input or an output.
12	S5	Source Terminal 5. Can be an input or an output.
13	V _{DD}	Most Positive Power Supply Potential.
14	GND	Ground (0 V) Reference.
15	A2	Logic Control Input.
16	A1	Logic Control Input.



1. THE EXPOSED PAD IS CONNECTED INTERNALLY. FOR INCREASED RELIABILITY OF THE SOLDER JOINTS AND MAXIMUM THERMAL CAPABILITY, IT IS RECOMMENDED THAT THE PAD BE SOLDERED TO THE SUBSTRATE, V_{SS} .

06713-004

Figure 5. 16-Lead LFCSP Pin Configuration (ADG1208)

Table 5. 16-Lead LFCSP Pin Function Descriptions (ADG1208)

Pin No.	Mnemonic	Description
1	V_{SS}	Most Negative Power Supply Potential. In single-supply applications, it can be connected to ground.
2	S1	Source Terminal 1. Can be an input or an output.
3	S2	Source Terminal 2. Can be an input or an output.
4	S3	Source Terminal 3. Can be an input or an output.
5	S4	Source Terminal 4. Can be an input or an output.
6	D	Drain Terminal. Can be an input or an output.
7	S8	Source Terminal 8. Can be an input or an output.
8	S7	Source Terminal 7. Can be an input or an output.
9	S6	Source Terminal 6. Can be an input or an output.
10	S5	Source Terminal 5. Can be an input or an output.
11	V_{DD}	Most Positive Power Supply Potential.
12	GND	Ground (0 V) Reference.
13	A2	Logic Control Input.
14	A1	Logic Control Input.
15	A0	Logic Control Input.
16	EN	Active High Digital Input. When low, the device is disabled and all switches are off. When high, Ax logic inputs determine on switches.
	EPAD	Exposed Pad. The exposed pad is connected internally. For increased reliability of the solder joints and maximum thermal capability, it is recommended that the pad be soldered to the substrate, V_{SS} .

Table 6. ADG1208 Truth Table

A2	A1	A0	EN	On Switch
X	X	X	0	None
0	0	0	1	1
0	0	1	1	2
0	1	0	1	3
0	1	1	1	4
1	0	0	1	5
1	0	1	1	6
1	1	0	1	7
1	1	1	1	8

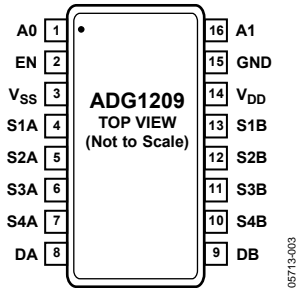

Figure 6. 16-Lead TSSOP Pin Configuration (ADG1209)

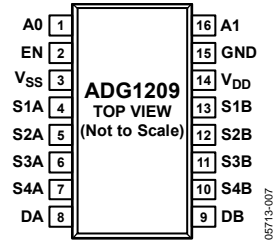
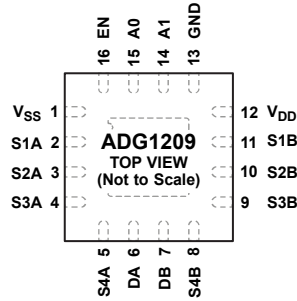

Figure 7. 16-Lead SOIC Pin Configuration (ADG1209)

Table 7. 16-Lead TSSOP and 16-Lead SOIC Pin Function Descriptions (ADG1209)

Pin No.	Mnemonic	Description
1	A0	Logic Control Input.
2	EN	Active High Digital Input. When low, the device is disabled and all switches are off. When high, Ax logic inputs determine on switches.
3	V _{SS}	Most Negative Power Supply Potential. In single-supply applications, it can be connected to ground.
4	S1A	Source Terminal 1A. Can be an input or an output.
5	S2A	Source Terminal 2A. Can be an input or an output.
6	S3A	Source Terminal 3A. Can be an input or an output.
7	S4A	Source Terminal 4A. Can be an input or an output.
8	DA	Drain Terminal A. Can be an input or an output.
9	DB	Drain Terminal B. Can be an input or an output.
10	S4B	Source Terminal 4B. Can be an input or an output.
11	S3B	Source Terminal 3B. Can be an input or an output.
12	S2B	Source Terminal 2B. Can be an input or an output.
13	S1B	Source Terminal 1B. Can be an input or an output.
14	V _{DD}	Most Positive Power Supply Potential.
15	GND	Ground (0 V) Reference.
16	A1	Logic Control Input.



1. THE EXPOSED PAD IS CONNECTED INTERNALLY. FOR INCREASED RELIABILITY OF THE SOLDER JOINTS AND MAXIMUM THERMAL CAPABILITY, IT IS RECOMMENDED THAT THE PAD BE SOLDERED TO THE SUBSTRATE, V_{SS}.

06713-005

Figure 8. 16-Lead LFCSP Pin Configuration (ADG1209)

Table 8. 16-Lead LFCSP Pin Function Descriptions (ADG1209)

Pin No.	Mnemonic	Description
1	V _{SS}	Most Negative Power Supply Potential. In single-supply applications, it can be connected to ground.
2	S1A	Source Terminal 1A. Can be an input or an output.
3	S2A	Source Terminal 2A. Can be an input or an output.
4	S3A	Source Terminal 3A. Can be an input or an output.
5	S4A	Source Terminal 4A. Can be an input or an output.
6	DA	Drain Terminal A. Can be an input or an output.
7	DB	Drain Terminal B. Can be an input or an output.
8	S4B	Source Terminal 4B. Can be an input or an output.
9	S3B	Source Terminal 3B. Can be an input or an output.
10	S2B	Source Terminal 2B. Can be an input or an output.
11	S1B	Source Terminal 1B. Can be an input or an output.
12	V _{DD}	Most Positive Power Supply Potential.
13	GND	Ground (0 V) Reference.
14	A1	Logic Control Input.
15	A0	Logic Control Input.
16	EN	Active High Digital Input. When low, the device is disabled and all switches are off. When high, Ax logic inputs determine on switches.
	EPAD	Exposed Pad. The exposed pad is connected internally. For increased reliability of the solder joints and maximum thermal capability, it is recommended that the pad be soldered to the substrate, V _{SS} .

Table 9. ADG1209 Truth Table

A1	A0	EN	On Switch Pair
X	X	0	None
0	0	1	1
0	1	1	2
1	0	1	3
1	1	1	4

TYPICAL PERFORMANCE CHARACTERISTICS

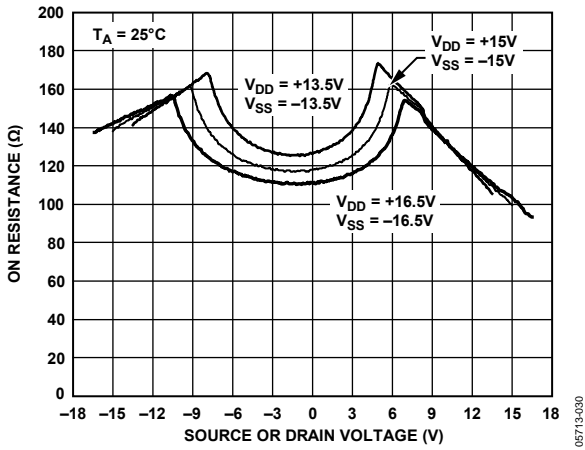

Figure 9. On Resistance as a Function of V_D (V_S) for Dual Supply

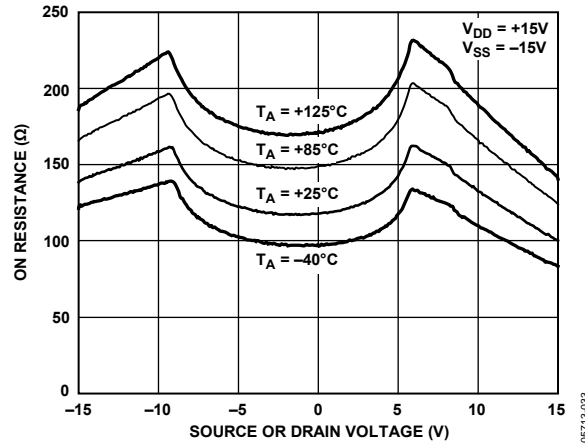

Figure 12. On Resistance as a Function of V_D (V_S) for Different Temperatures, Dual Supply

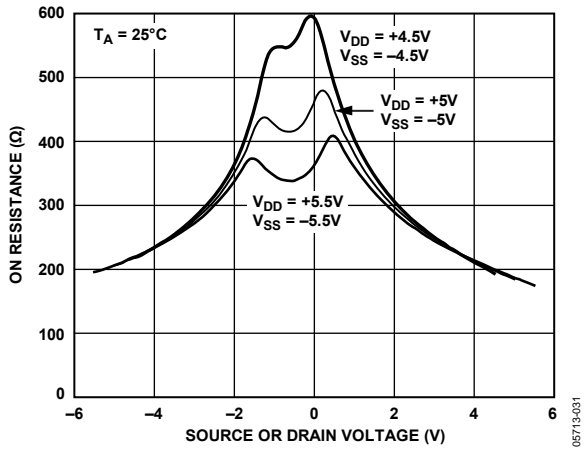

Figure 10. On Resistance as a Function of V_D (V_S) for Dual Supply

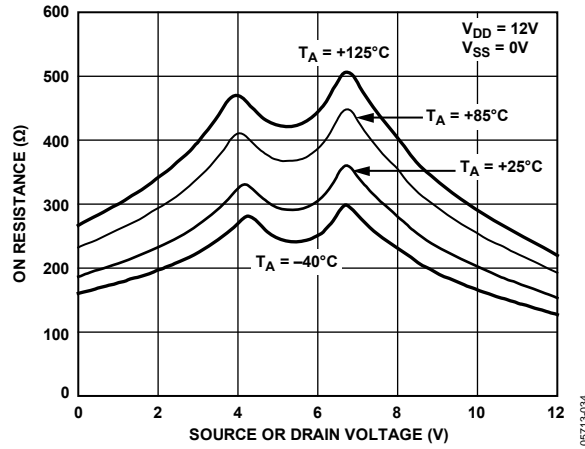

Figure 13. On Resistance as a Function of V_D (V_S) for Different Temperatures, Single Supply

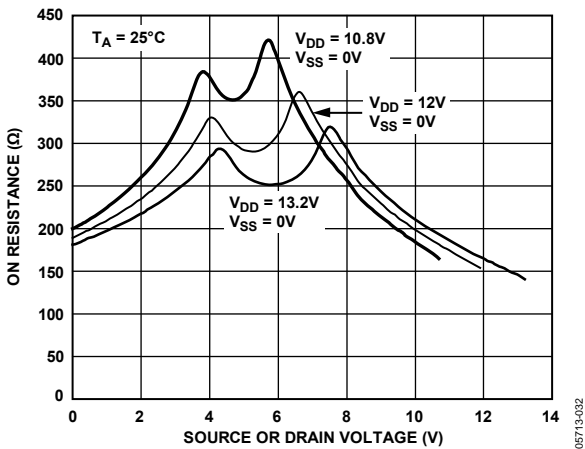

Figure 11. On Resistance as a Function of V_D (V_S) for Single Supply

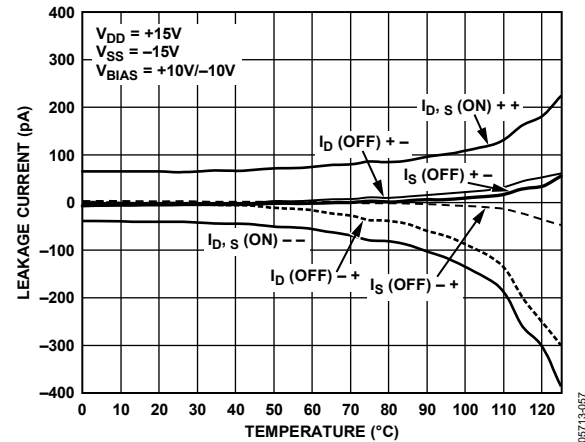

Figure 14. ADG1208 Leakage Currents as a Function of Temperature, Dual Supply

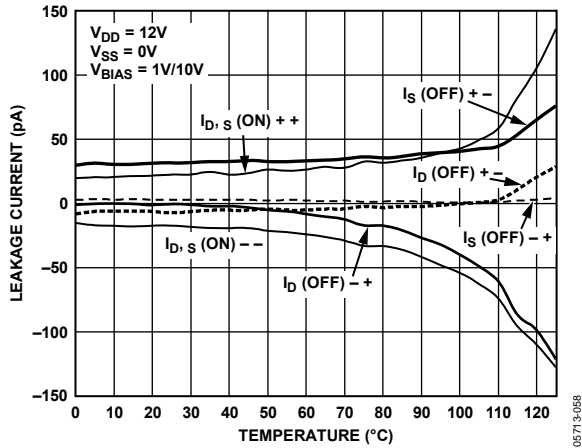

Figure 15. ADG1208 Leakage Currents as a Function of Temperature, Single Supply

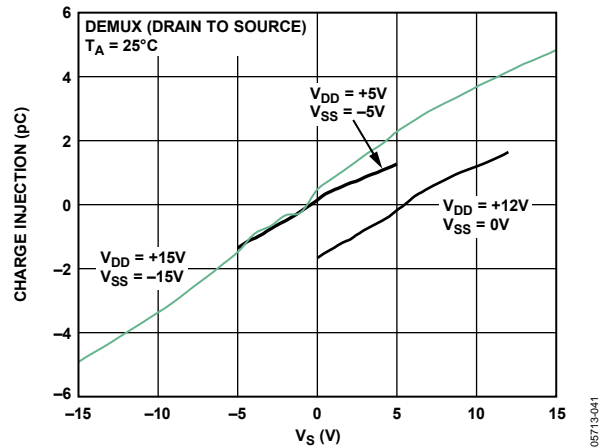

Figure 18. Drain-to-Source Charge Injection vs. Source Voltage

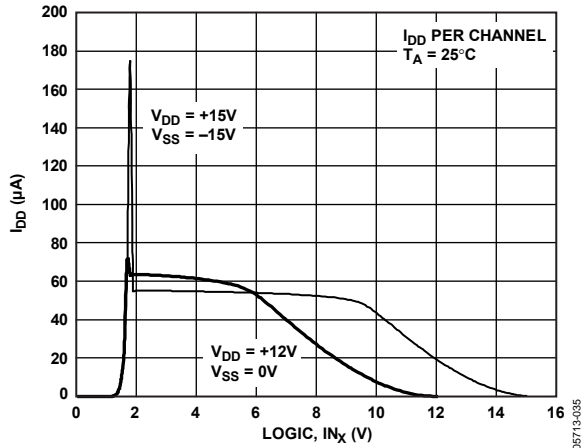

Figure 16. I_{DD} vs. Logic Level

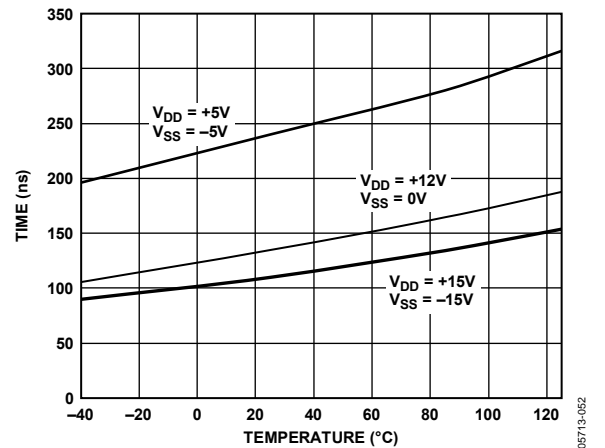

Figure 19. t_{ON}/t_{OFF} Times vs. Temperature

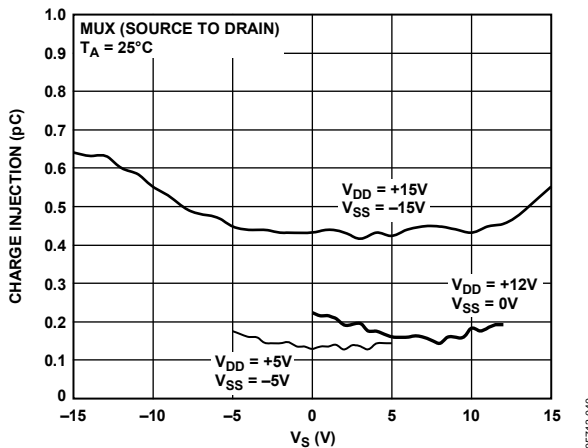

Figure 17. Source-to-Drain Charge Injection vs. Source Voltage

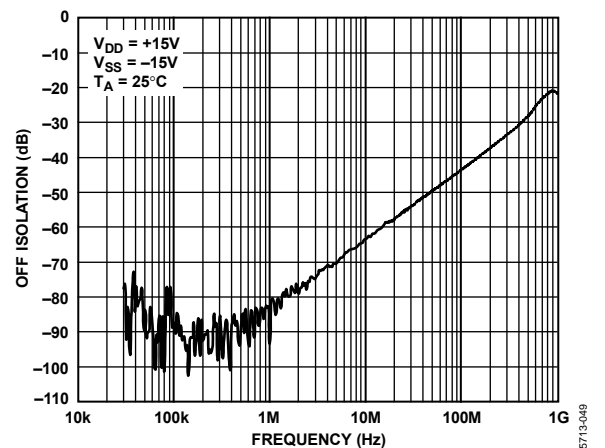

Figure 20. Off Isolation vs. Frequency

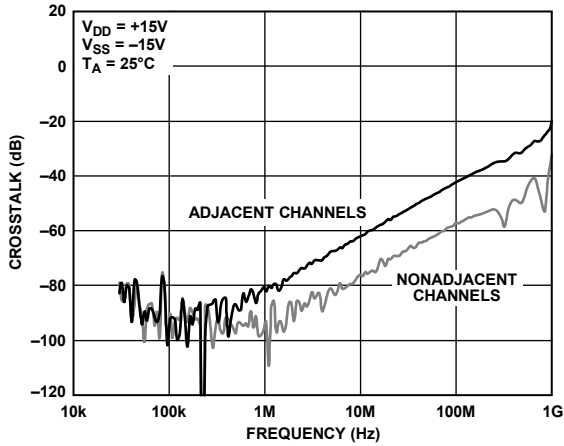

Figure 21. ADG1208 Crosstalk vs. Frequency

05713-042

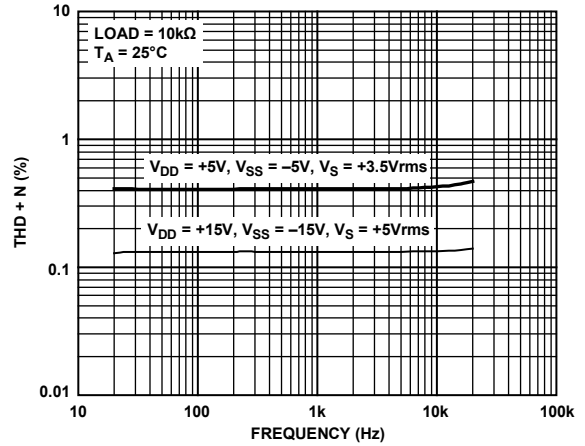

Figure 24. THD + N vs. Frequency

05713-036

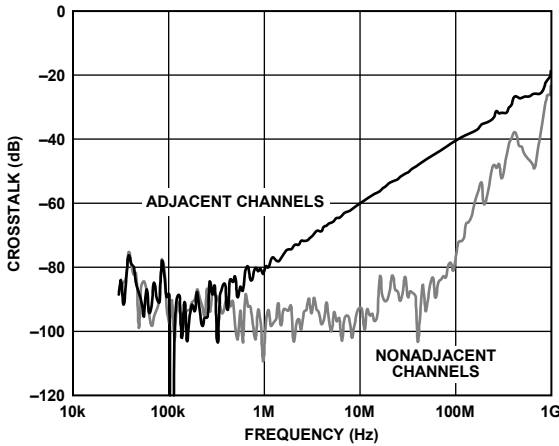

Figure 22. ADG1209 Crosstalk vs. Frequency

05713-053

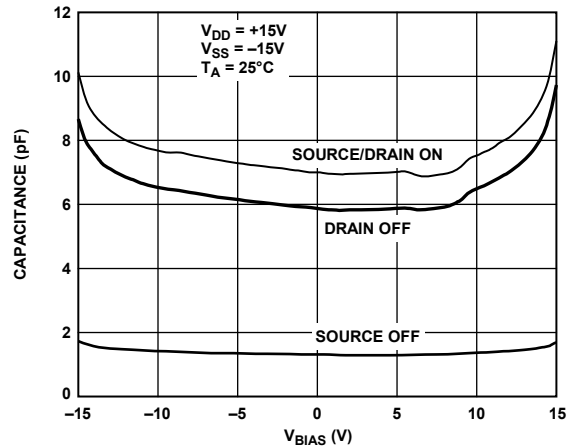

Figure 25. ADG1208 Capacitance vs. Source Voltage, ±15 V Dual Supply

05713-043

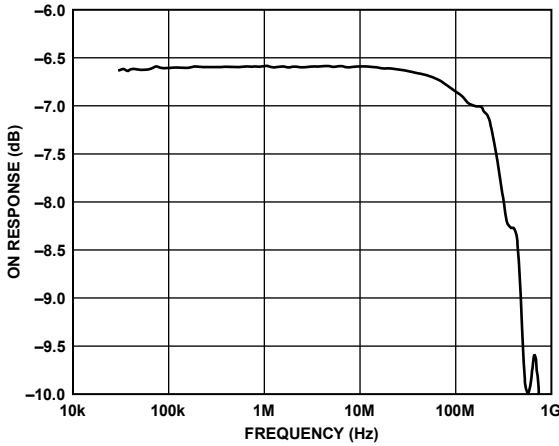

Figure 23. On Response vs. Frequency

05713-054

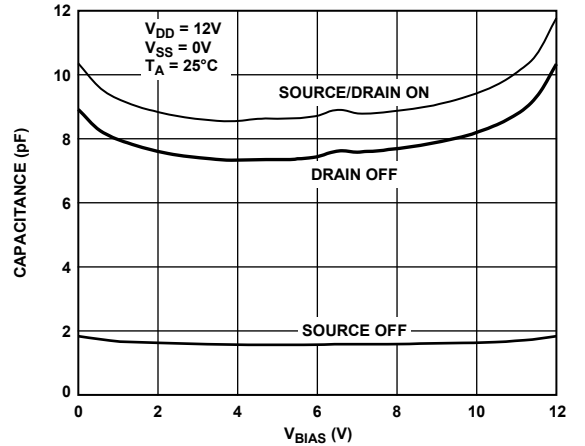

Figure 26. ADG1208 Capacitance vs. Source Voltage, 12 V Single Supply

05713-045

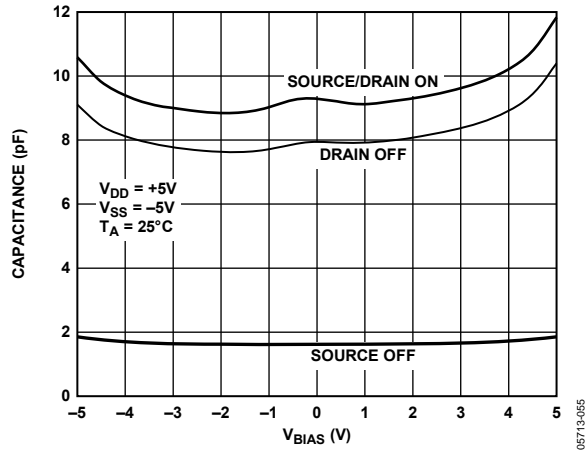

Figure 27. ADG1208 Capacitance vs. Source Voltage, ±5 V Dual Supply

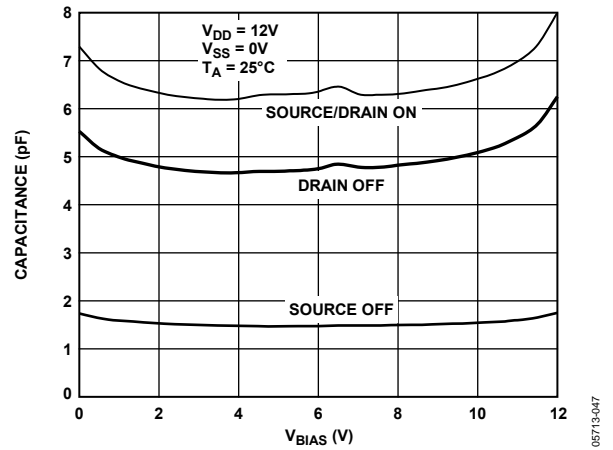

Figure 29. ADG1209 Capacitance vs. Source Voltage, 12 V Single Supply

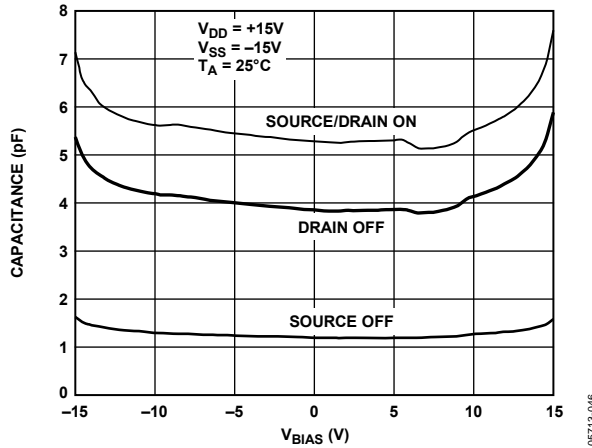

Figure 28. ADG1209 Capacitance vs. Source Voltage, ±15 V Dual Supply

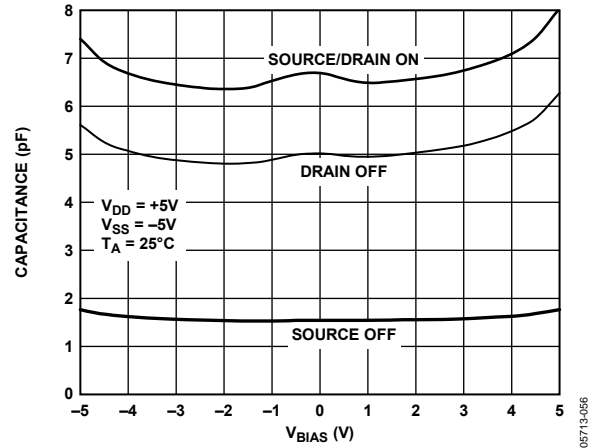

Figure 30. ADG1209 Capacitance vs. Source Voltage, ±5 V Dual Supply

TERMINOLOGY

R_{ON}

Ohmic resistance between D and S.

ΔR_{ON}

Difference between the R_{ON} of any two channels.

I_S (Off)

Source leakage current when the switch is off.

I_D (Off)

Drain leakage current when the switch is off.

I_D, I_S (On)

Channel leakage current when the switch is on.

V_D (V_S)

Analog voltage on Terminal D, Terminal S.

C_S (Off)

Channel input capacitance for off condition.

C_D (Off)

Channel output capacitance for off condition.

C_D, C_S (On)

On switch capacitance.

C_{IN}

Digital input capacitance.

t_{ON} (EN)

Delay time between the 50% and 90% points of the digital input and switch on condition.

t_{OFF} (EN)

Delay time between the 50% and 90% points of the digital input and switch off condition.

$t_{TRANSITION}$

Delay time between the 50% and 90% points of the digital inputs and the switch on condition when switching from one address state to another.

T_{BBM}

Off time measured between the 80% point of both switches when switching from one address state to another.

V_{INL}

Maximum input voltage for Logic 0.

V_{INH}

Minimum input voltage for Logic 1.

I_{INL} (I_{INH})

Input current of the digital input.

I_{DD}

Positive supply current.

I_{SS}

Negative supply current.

Off Isolation

A measure of unwanted signal coupling through an off channel.

Charge Injection

A measure of the glitch impulse transferred from the digital input to the analog output during switching.

Bandwidth

The frequency at which the output is attenuated by 3 dB.

On Response

The frequency response of the on switch.

Total Harmonic Distortion Plus Noise (THD + N)

The ratio of the harmonic amplitude plus noise of the signal to the fundamental.

TEST CIRCUITS

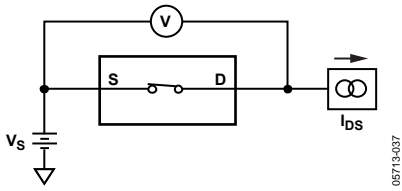

Figure 31. On Resistance

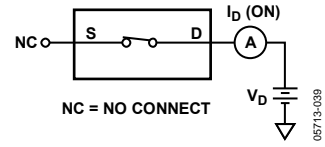

Figure 33. On Leakage

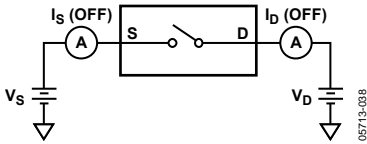

Figure 32. Off Leakage

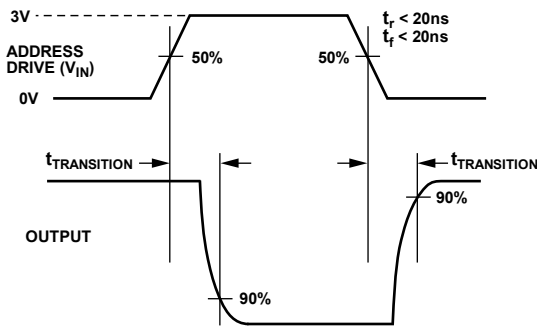
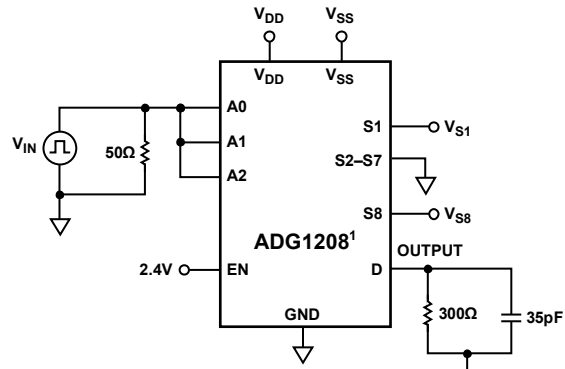

Figure 34. Address to Output Switching Times, $t_{TRANSITION}$



¹SIMILAR CONNECTION FOR ADG1209.

05713-022

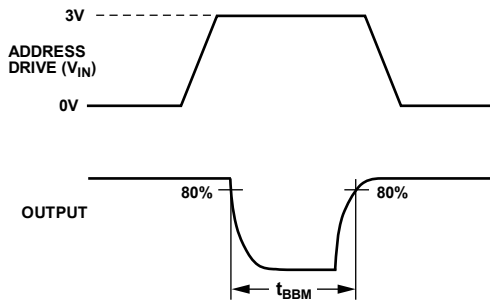
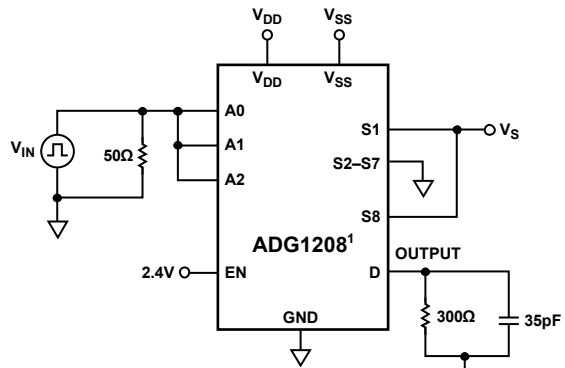
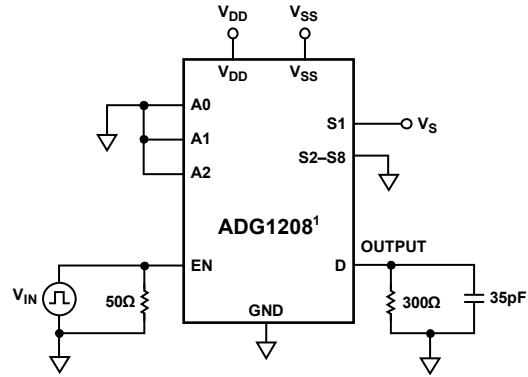
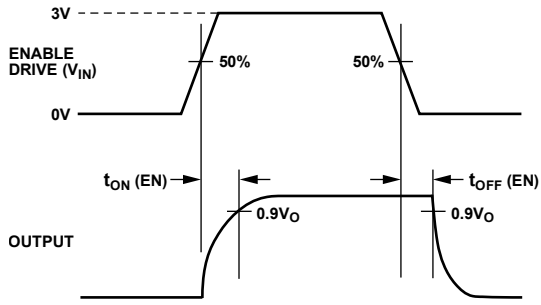

Figure 35. Break-Before-Make Delay, t_{BBM}



¹SIMILAR CONNECTION FOR ADG1209.

05713-023



¹SIMILAR CONNECTION FOR ADG1209.

05713-024

Figure 36. Enable Delay, $t_{ON}(EN)$, $t_{OFF}(EN)$

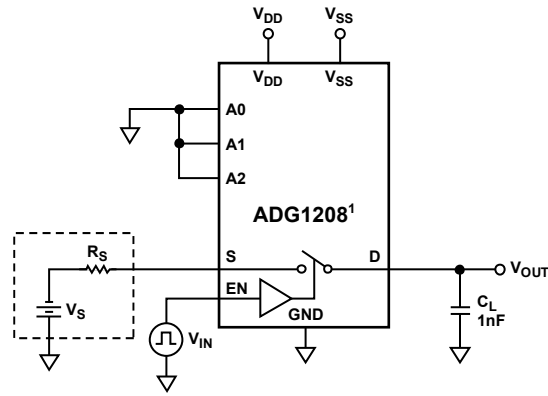
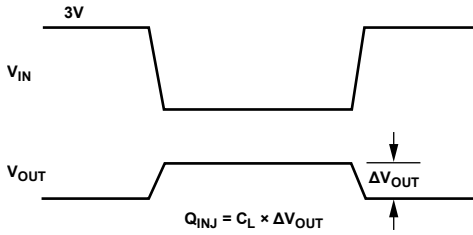

¹SIMILAR CONNECTION FOR ADG1209.

05713-025

Figure 37. Charge Injection

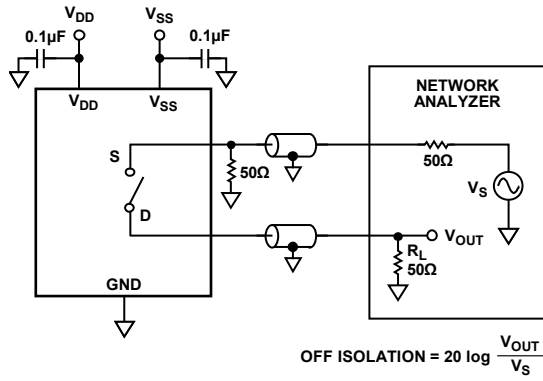

Figure 38. Off Isolation

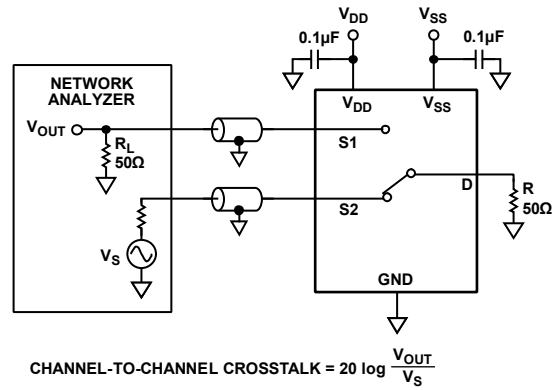

Figure 40. Channel to Channel Crosstalk

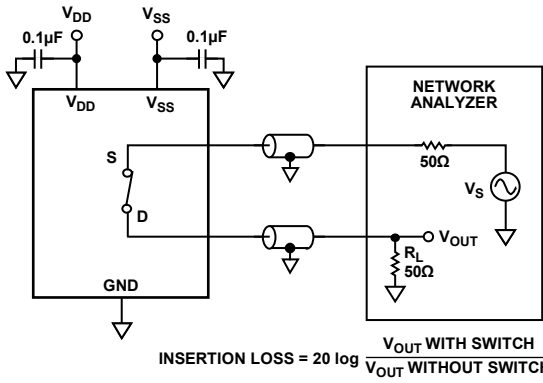

Figure 39. Bandwidth

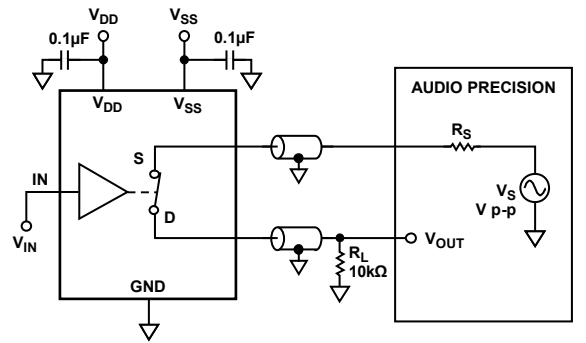
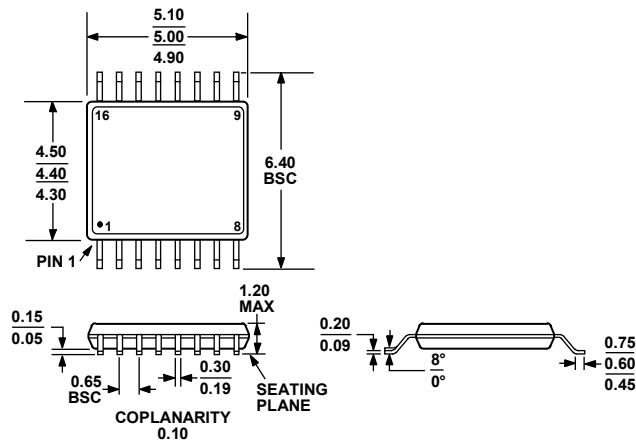

Figure 41. THD + N

OUTLINE DIMENSIONS



COMPLIANT TO JEDEC STANDARDS MO-153-AB

Figure 42. 16-Lead Thin Shrink Small Outline Package [TSSOP] (RU-16)
Dimensions shown in millimeters

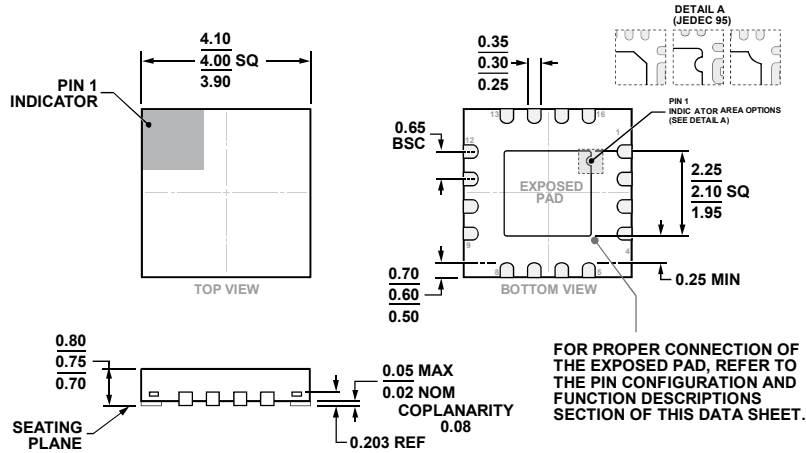

COMPLIANT TO JEDEC STANDARDS MO-220-WGGC.

Figure 43. 16-Lead Lead Frame Chip Scale Package [LFCSP] 4 mm x 4 mm Body and 0.75 mm Package Height (CP-16-23)
Dimensions shown in millimeters

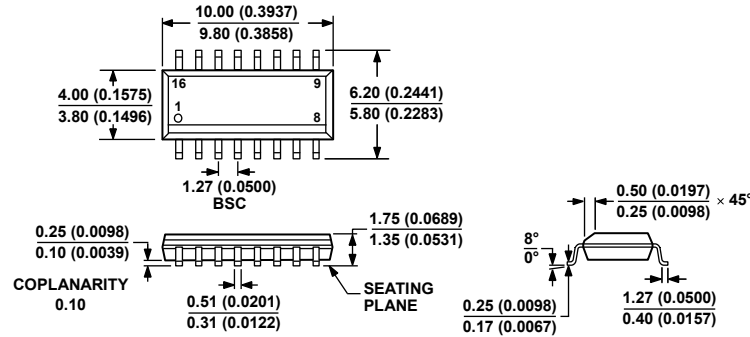

COMPLIANT TO JEDEC STANDARDS MS-012-AC
 CONTROLLING DIMENSIONS ARE IN MILLIMETERS; INCH DIMENSIONS
 (IN PARENTHESES) ARE ROUNDED-OFF MILLIMETER EQUIVALENTS FOR
 REFERENCE ONLY AND ARE NOT APPROPRIATE FOR USE IN DESIGN.

060606-A

Figure 44. 16-Lead Standard Small Outline Package [SOIC_N]
 Narrow Body (R-16)
 Dimensions shown in millimeters and (inches)

ORDERING GUIDE

Model ¹	Temperature Range	Package Description	Package Option
ADG1208YRUZ	-40°C to +125°C	16-Lead Thin Shrink Small Outline Package [TSSOP]	RU-16
ADG1208YRUZ-REEL7	-40°C to +125°C	16-Lead Thin Shrink Small Outline Package [TSSOP]	RU-16
ADG1208YCPZ-REEL	-40°C to +125°C	16-Lead Lead Frame Chip Scale Package [LFCSP]	CP-16-23
ADG1208YCPZ-REEL7	-40°C to +125°C	16-Lead Lead Frame Chip Scale Package [LFCSP]	CP-16-23
ADG1208YRZ	-40°C to +125°C	16-Lead Narrow Body Small Outline Package [SOIC_N]	R-16
ADG1208YRZ-REEL7	-40°C to +125°C	16-Lead Narrow Body Small Outline Package [SOIC_N]	R-16
ADG1209YRUZ	-40°C to +125°C	16-Lead Thin Shrink Small Outline Package [TSSOP]	RU-16
ADG1209YRUZ-REEL7	-40°C to +125°C	16-Lead Thin Shrink Small Outline Package [TSSOP]	RU-16
ADG1209YCPZ-REEL7	-40°C to +125°C	16-Lead Lead Frame Chip Scale Package [LFCSP]	CP-16-23
ADG1209YRZ	-40°C to +125°C	16-Lead Narrow Body Small Outline Package [SOIC_N]	R-16
ADG1209YRZ-REEL7	-40°C to +125°C	16-Lead Narrow Body Small Outline Package [SOIC_N]	R-16

¹ Z = RoHS Compliant Part.

Looking for pricing, stock, or lifecycle information?

Click below to explore more details on WIN SOURCE:

 [View ADG1209YRUZ on WIN SOURCE](#)

 [Analog Devices Inc. Information](#)

Optimize Your Supply Chain with WIN SOURCE Solutions

-  Global Sourcing Solution
-  Obsolete Management
-  Cost Control Management
-  Shortage Management
-  Alternative Solution
-  Excess Inventory Management