



**THE DATASHEET OF  
ADS62P49IRGCT**



## Dual Channel 14-/12-Bit, 250-/210-MSPS ADC With DDR LVDS and Parallel CMOS Outputs

 Check for Samples: [ADS62P49 / ADS62P29](#), [ADS62P48 / ADS62P28](#)

### FEATURES

- Maximum Sample Rate: 250 MSPS
- 14-Bit Resolution – ADS62P49/ADS62P48
- 12-Bit Resolution – ADS62P29/ADS62P28
- Total Power: 1.25 W at 250 MSPS
- Double Data Rate (DDR) LVDS and Parallel CMOS Output Options
- Programmable Gain up to 6dB for SNR/SFDR Trade-Off
- DC Offset Correction
- 90dB Cross-Talk

- Supports Input Clock Amplitude Down to 400 mV<sub>PP</sub> Differential
- Internal and External Reference Support
- 64-QFN Package (9 mm × 9 mm)

**ADS62Pxx High Speed Family**

	250 MSPS	210 MSPS	200 MSPS
14-Bit Family	ADS62P49	ADS62P48	
12-Bit Family	ADS62P29	ADS62P28	
11-Bit Family			ADS62C17

### DESCRIPTION

The ADS62Pxx9/xx8 is a family of dual channel 14-bit and 12-bit A/D converters with sampling rates up to 250 MSPS. It combines high dynamic performance and low power consumption in a compact 64 QFN package. This makes it well-suited for multi-carrier, wide band-width communications applications.

The ADS62Pxx9/xx8 has gain options that can be used to improve SFDR performance at lower full-scale input ranges. It includes a dc offset correction loop that can be used to cancel the ADC offset. Both DDR LVDS (Double Data Rate) and parallel CMOS digital output interfaces are available.

It includes internal references while the traditional reference pins and associated decoupling capacitors have been eliminated. Nevertheless, the device can also be driven with an external reference. The device is specified over the industrial temperature range (–40°C to 85°C).

**Table 1. Performance Summary**

AT 170MHZ INPUT		ADS62P49	ADS62P48	ADS62P29	ADS62P28
SFDR, dBc	0 dB gain	75	78	75	78
	6 dB gain	82	84	82	84
SINAD, dBFS	0 dB gain	69.8	70.1	68.3	68.7
	6 dB gain	66.5	66.3	65.8	65.8
Analog Power, W		1	0.92	1	0.92



Please be aware that an important notice concerning availability, standard warranty, and use in critical applications of Texas Instruments semiconductor products and disclaimers thereto appears at the end of this data sheet.

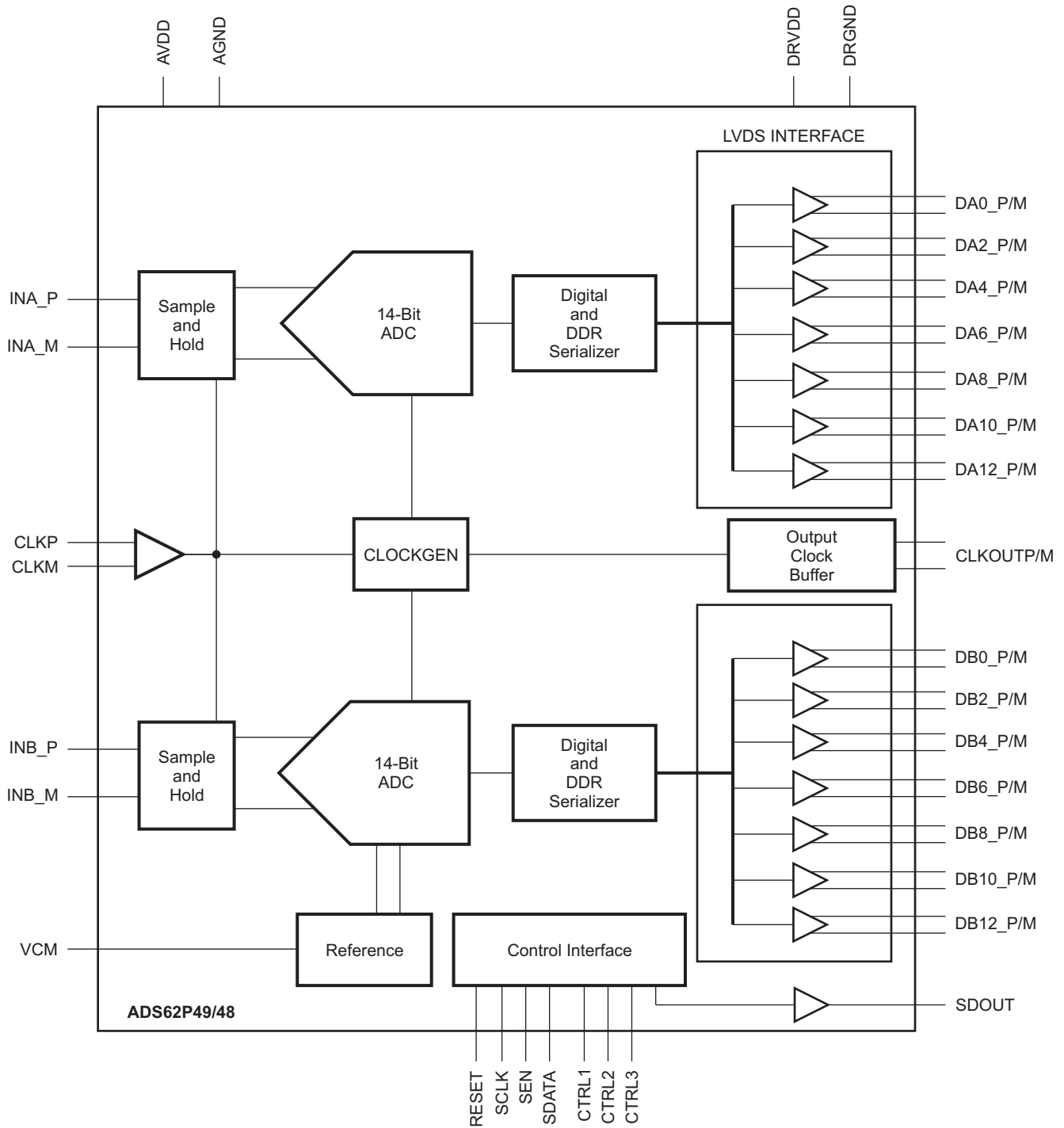

B0349-01

Figure 1. ADS62P49/48 Block Diagram

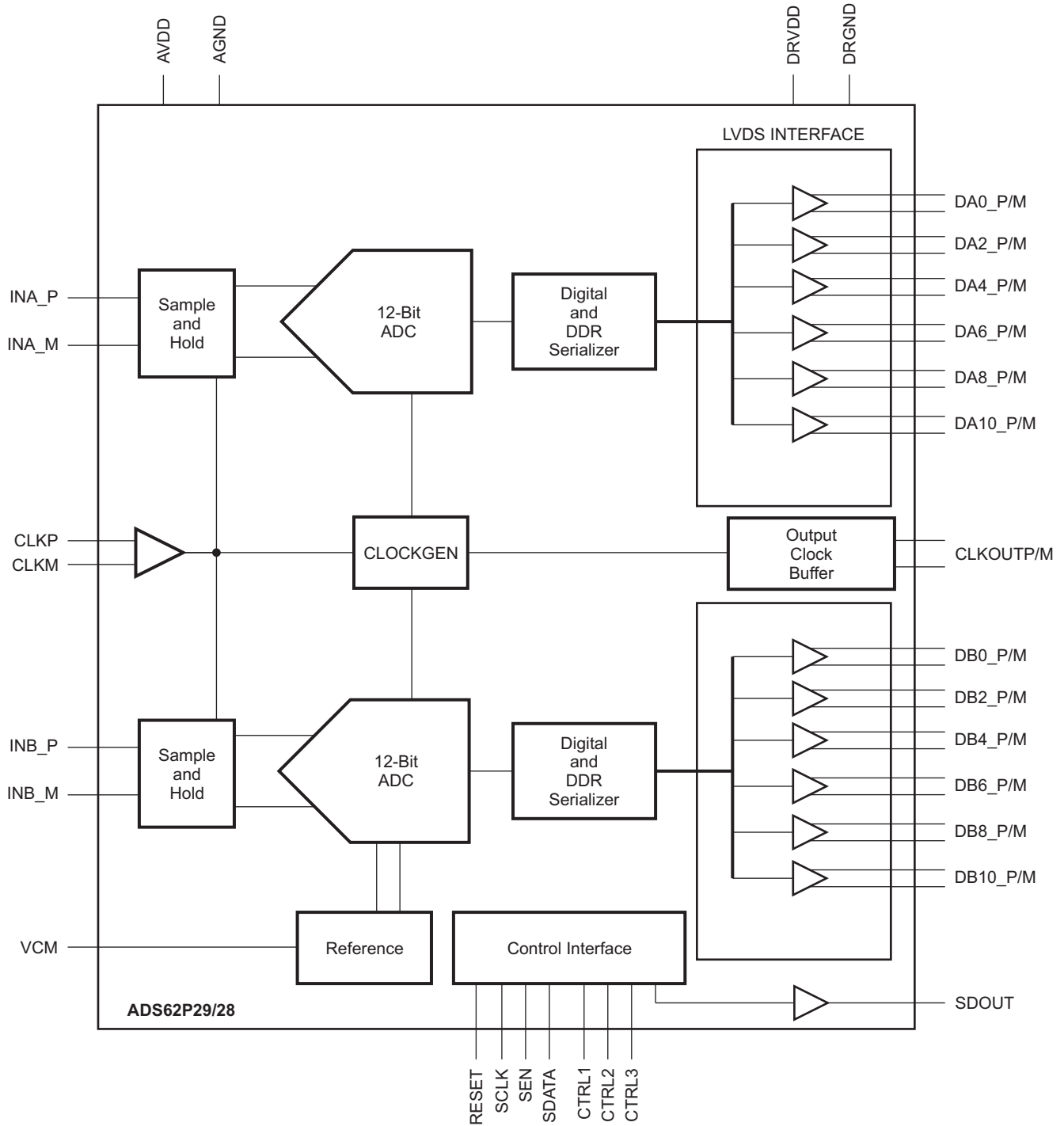

B0350-01

Figure 2. ADS62P29/28 Block Diagram

**PACKAGE/ORDERING INFORMATION<sup>(1)</sup>**

PRODUCT	PACKAGE-LEAD	PACKAGE DESIGNATOR	SPECIFIED TEMPERATURE RANGE	ECO PLAN <sup>(2)</sup>	LEAD/BALL FINISH	PACKAGE MARKING	ORDERING NUMBER	TRANSPORT MEDIA, QUANTITY
ADS62P49	QFN-64	RGC	-40°C to 85°C	GREEN (RoHS and no Sb/Br)	Cu NiPdAu	AZ62P49	ADS62P49IRGCT, ADS62P49IRGCR	Tape and Reel
ADS62P48						AZ62P48	ADS62P48IRGCT, ADS62P48IRGCR	
ADS62P29						AZ62P29	ADS62P29IRGCT, ADS62P29IRGCR	Tape and Reel
ADS62P28						AZ62P28	ADS62P28IRGCT, ADS62P28IRGCR	

- (1) For the most current product and ordering information, see the Package Option Addendum at the end of this document, or see the TI web site at [www.ti.com](http://www.ti.com).
- (2) Eco Plan – The planned eco-friendly classification: Green (RoHS and no Sb/Br): TI defines “Green” to mean Pb-Free (RoHS compatible) and free of Bromine (Br) and Antimony (Sb) based flame retardants.

**ABSOLUTE MAXIMUM RATINGS<sup>(1)</sup>**

over operating free-air temperature range (unless otherwise noted)

	VALUE	UNIT
Supply voltage range, AVDD	-0.3 V to 3.9	V
Supply voltage range, DRVDD	-0.3 V to 2.2	V
Voltage between AGND and DRGND	-0.3 to 0.3	V
Voltage between AVDD to DRVDD (AVDD leads DRVDD during power up/DRVDD leads AVDD during power down)	-0.3 to 4.2	V
Voltage between DRVDD to AVDD (DRVDD leads AVDD during power up/AVDD leads DRVDD during power down)	-2.5 to 1.7	V
Voltage applied to external pin, VCM (in external reference mode)	-0.3 to 2.0	V
Voltage applied to analog input pins – INP_A, INM_A, INP_B, INM_B	-0.3V to minimum ( 3.6, AVDD + 0.3V )	V
Voltage applied to input pins - CLKP, CLKM <sup>(2)</sup> , RESET, SCLK, SDATA, SEN, CTRL1, CTRL2, CTRL3	-0.3V to AVDD + 0.3V	V
T <sub>A</sub> Operating free-air temperature range	-40 to 85	°C
T <sub>J</sub> Operating junction temperature range	125	°C
T <sub>stg</sub> Storage temperature range	-65 to 150	°C
ESD, human body model	2	kV

- (1) Stresses beyond those listed under *absolute maximum ratings* may cause permanent damage to the device. These are stress ratings only and functional operation of the device at these or any other conditions beyond those indicated under *recommended operating conditions* is not implied. Exposure to absolute maximum rated conditions for extended periods may affect device reliability.
- (2) When AVDD is turned off, it is recommended to switch off the input clock (or ensure the voltage on CLKP, CLKM is < |0.3V|). This prevents the ESD protection diodes at the clock input pins from turning on.

**THERMAL INFORMATION**

THERMAL METRIC <sup>(1)</sup>		ADS62Pxx	UNITS
		RGC PACKAGE	
		64 PINS	
$\theta_{JA}$	Junction-to-ambient thermal resistance <sup>(2)</sup>	23.0	°C/W
$\theta_{JcTop}$	Junction-to-case (top) thermal resistance <sup>(3)</sup>	10.5	
$\theta_{JB}$	Junction-to-board thermal resistance <sup>(4)</sup>	4.2	
$\psi_{JT}$	Junction-to-top characterization parameter <sup>(5)</sup>	0.1	
$\psi_{JB}$	Junction-to-board characterization parameter <sup>(6)</sup>	4.2	
$\theta_{JcBot}$	Junction-to-case (bottom) thermal resistance <sup>(7)</sup>	0.57	

- (1) For more information about traditional and new thermal metrics, see the *IC Package Thermal Metrics* application report, [SPRA953](#).
- (2) The junction-to-ambient thermal resistance under natural convection is obtained in a simulation on a JEDEC-standard, high-K board, as specified in JESD51-7, in an environment described in JESD51-2a.
- (3) The junction-to-case (top) thermal resistance is obtained by simulating a cold plate test on the package top. No specific JEDEC-standard test exists, but a close description can be found in the ANSI SEMI standard G30-88.
- (4) The junction-to-board thermal resistance is obtained by simulating in an environment with a ring cold plate fixture to control the PCB temperature, as described in JESD51-8.
- (5) The junction-to-top characterization parameter,  $\psi_{JT}$ , estimates the junction temperature of a device in a real system and is extracted from the simulation data for obtaining  $\theta_{JA}$ , using a procedure described in JESD51-2a (sections 6 and 7).
- (6) The junction-to-board characterization parameter,  $\psi_{JB}$ , estimates the junction temperature of a device in a real system and is extracted from the simulation data for obtaining  $\theta_{JA}$ , using a procedure described in JESD51-2a (sections 6 and 7).
- (7) The junction-to-case (bottom) thermal resistance is obtained by simulating a cold plate test on the exposed (power) pad. No specific JEDEC standard test exists, but a close description can be found in the ANSI SEMI standard G30-88.

## RECOMMENDED OPERATING CONDITIONS

		MIN	TYP	MAX	UNIT
<b>SUPPLIES</b>					
AVDD	Analog supply voltage	3.15	3.3	3.6	V
DRVDD	Digital supply voltage	1.7	1.8	1.9	V
<b>ANALOG INPUTS</b>					
Differential input voltage range		2			V <sub>PP</sub>
Input common-mode voltage		1.5 ±0.1			V
Voltage applied on CM in external reference mode		1.5±0.05			V
Maximum analog input frequency with 2 V <sub>pp</sub> input amplitude <sup>(1)</sup>		500			MHz
Maximum analog input frequency with 1 V <sub>pp</sub> input amplitude <sup>(1)</sup>		800			MHz
<b>CLOCK INPUT</b>					
Input clock sample rate					
ADS62P49 / ADS62P29	Enable low speed mode <sup>(2)</sup>	1	80		MSPS
	Low speed mode disabled (default mode after reset)	>80	250 <sup>(3)</sup>		
ADS62P48 / ADS62P28	Enable low speed mode <sup>(2)</sup>	1	80		MSPS
	Low speed mode disabled (default mode after reset)	>80	210		
	With multiplexed mode enabled <sup>(4)</sup>	1	65		MSPS
Input clock amplitude differential (V <sub>CLKP</sub> –V <sub>CLKM</sub> ) <sup>(5)(6)</sup>					
Sine wave, ac-coupled		0.2	1.5	V <sub>PP</sub>	
LVPECL, ac-coupled		1.6			V <sub>PP</sub>
LVDS, ac-coupled		0.7			V <sub>PP</sub>
LVCMOS, single-ended, ac-coupled		3.3			V
Input clock duty cycle		40%	50%	60%	
<b>DIGITAL OUTPUTS</b>					
C <sub>LOAD</sub>	Maximum external load capacitance from each output pin to DRGND	5			pF
R <sub>LOAD</sub>	Differential load resistance between the LVDS output pairs (LVDS mode)	100			Ω
T <sub>A</sub>	Operating free-air temperature	–40	85		°C

- (1) See the [Theory of Operation](#) section for information.
- (2) Use register bit <ENABLE LOW SPEED MODE>, refer to the [Serial Register Map](#) section for information.
- (3) With LVDS interface only; maximum recommended sample rate with CMOS interface is 210 MSPS.
- (4) See the [Multiplexed Output Mode](#) section for information.
- (5) Refer to Performance vs Input Clock Amplitude Chart on [Figure 35](#), [Figure 52](#), [Figure 69](#), and [Figure 86](#).
- (6) Refer to [Figure 3](#) for the definition of clock amplitude.

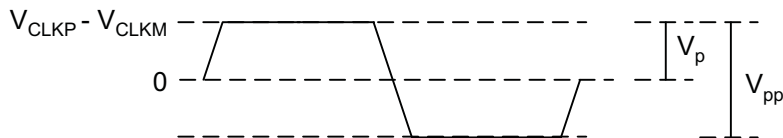

Figure 3. Clock Amplitude Definition Diagram

## ELECTRICAL CHARACTERISTICS – ADS62P49/48 and ADS62P29/28

Typical values are at 25°C, AVDD = 3.3V, DRVDD = 1.8V, 50% clock duty cycle, –1dBFS differential analog input, internal reference mode (unless otherwise noted).

Min and max values are across the full temperature range  $T_{MIN} = -40^{\circ}\text{C}$  to  $T_{MAX} = 85^{\circ}\text{C}$ , AVDD = 3.3V, DRVDD = 1.8V

PARAMETER		ADS62P49/ADS62P29 250 MSPS			ADS62P48/ADS62P28 210 MSPS			UNIT
		MIN	TYP	MAX	MIN	TYP	MAX	
<b>ANALOG INPUT</b>								
	Differential input voltage range (0 dB gain)	2			2			V <sub>pp</sub>
	Differential input resistance (at dc), See <a href="#">Figure 100</a>	> 1			> 1			MΩ
	Differential input capacitance, See <a href="#">Figure 101</a>	3.5			3.5			pF
	Analog input bandwidth (with 25Ω source impedance)	700			700			MHz
	Analog Input common mode current (per channel)	3.6			3.6			μA/MSPS
VCM	Common mode output voltage	1.5			1.5			V
VCM	Output current capability	±4			±4			mA
<b>DC ACCURACY</b>								
	Offset error	–20	±2	20	–20	±2	20	mV
	Temperature coefficient of offset error	0.02			0.02			mV/°C
	Variation of offset error with supply	0.5			0.5			mV/V
	There are two sources of gain error – internal reference inaccuracy and channel gain error.							
E <sub>GREF</sub>	Gain error due to internal reference inaccuracy alone	–1	±0.2	1	–1	±0.2	1	% FS
E <sub>GCHAN</sub>	Gain error of channel alone <sup>(1)</sup>	–1	±0.2	1	–1	±0.2	1	% FS
	Temperature coefficient of E <sub>GCHAN</sub>	0.002			0.002			Δ% /°C
Gain matching <sup>(2)</sup>	Difference in gain errors between two channels within the same device	–2		2	–2		2	% FS
	Difference in gain errors between two channels across two devices	–4		4	–4		4	
<b>POWER SUPPLY</b>								
IAVDD	Analog supply current	305	350		280	320		mA
IDRVDD	Output buffer supply current, LVDS interface with 100 Ω external termination	133	175		122	165		mA
IDRVDD	Output buffer supply current, CMOS interface, Fin = 2MHz, No external load capacitance <sup>(3) (4)</sup>			–	91			mA
	Analog power	1.01	1.15		0.92	1.05		W
	Digital power, LVDS interface	0.24	0.315		0.22	0.3		W
	Global power down	45	100		45	100		mW

(1) This is specified by design and characterization; it is not tested in production.

(2) For two channels within the same device, only the channel gain error matters, as the reference is common for both channels.

(3) In CMOS mode, the DRVDD current scales with the sampling frequency, the load capacitance on output pins, input frequency and the supply voltage (see [Figure 92](#) and CMOS interface power dissipation in application section).

(4) The maximum DRVDD current with CMOS interface depends on the actual load capacitance on the digital output lines. Note that the maximum recommended load capacitance on each digital output line is 10 pF.

### ELECTRICAL CHARACTERISTICS – ADS62P49/48

Typical values are at 25°C, AVDD = 3.3V, DRVDD = 1.8V, 50% clock duty cycle, –1dBFS differential analog input, 0 dB gain, internal reference mode (unless otherwise noted).

Min and max values are across the full temperature range T<sub>MIN</sub> = –40°C to T<sub>MAX</sub> = 85°C, AVDD = 3.3V, DRVDD = 1.8V

PARAMETER	TEST CONDITIONS	ADS62P49 250 MSPS			ADS62P48 210 MSPS			UNIT
		MIN	TYP	MAX	MIN	TYP	MAX	
<b>SNR</b> Signal to noise ratio, LVDS	Fin= 20 MHz	73.4			73.4			dBFS
	Fin = 60 MHz	73			73			
	Fin = 100 MHz	72			72			
	Fin = 170 MHz	0 dB gain	68	71	68	71		
		6 dB gain	66.6			66.4		
Fin = 230 MHz	69.8			69.7				
<b>SINAD</b> Signal to noise and distortion ratio, LVDS	Fin= 20 MHz	73.2			73			dBFS
	Fin = 60 MHz	72.7			72.8			
	Fin = 100 MHz	71.2			71.5			
	Fin = 170 MHz	0 dB gain	66.5	69.8	66.5	70.1		
		6 dB gain	66.5			66.3		
Fin = 230 MHz	69			68				
<b>ENOB</b> , Effective number of bits	Fin = 170 MHz	11.3			11.4			LSB
<b>DNL</b> Differential non-linearity	Fin = 170 MHz	–0.95	±0.6	1.3	–0.95	±0.6	1.3	LSB
<b>INL</b> Integrated non-linearity	Fin = 170 MHz	–5	±2.5	5	–5	±2.5	5	LSB

### ELECTRICAL CHARACTERISTICS – ADS62P29/28

Typical values are at 25°C, AVDD = 3.3V, DRVDD = 1.8V, 50% clock duty cycle, –1dBFS differential analog input, 0 dB gain, internal reference mode (unless otherwise noted).

Min and max values are across the full temperature range T<sub>MIN</sub> = –40°C to T<sub>MAX</sub> = 85°C, AVDD = 3.3V, DRVDD = 1.8V

PARAMETER	TEST CONDITIONS	ADS62P29 250 MSPS			ADS62P28 210 MSPS			UNIT
		MIN	TYP	MAX	MIN	TYP	MAX	
<b>SNR</b> Signal to noise ratio, LVDS	Fin= 20 MHz	70.7			70.8			dBFS
	Fin = 60 MHz	70.5			70.6			
	Fin = 100 MHz	69.8			70			
	Fin = 170 MHz	0 dB gain	66.5	69.4	66.5	69.4		
		6 dB gain	66			65.9		
Fin = 230 MHz	68.4			68.4				
<b>SINAD</b> Signal to noise and distortion ratio, LVDS	Fin= 20 MHz	70.6			70.6			dBFS
	Fin = 60 MHz	70.3			70.5			
	Fin = 100 MHz	69.3			69.7			
	Fin = 170 MHz	0 dB gain	66	68.3	66	68.7		
		6 dB gain	65.9			65.8		
Fin = 230 MHz	67.9			67.1				
<b>ENOB</b> , Effective number of bits	Fin = 170 MHz	11			11.1			LSB
<b>DNL</b> Differential non-linearity		–0.9	±0.2	1.3	–0.9	±0.2	1.3	LSB
<b>INL</b> Integrated non-linearity		–5	±1	5	–5	±1	5	LSB

## ELECTRICAL CHARACTERISTICS – ADS62P49/48

Typical values are at 25°C, AVDD = 3.3V, DRVDD = 1.8V, 50% clock duty cycle, –1dBFS differential analog input, 0 dB gain, internal reference mode (unless otherwise noted).

Min and max values are across the full temperature range  $T_{MIN} = -40^{\circ}\text{C}$  to  $T_{MAX} = 85^{\circ}\text{C}$ , AVDD = 3.3V, DRVDD = 1.8V

PARAMETER	TEST CONDITIONS	ADS62P49/ADS62P29 250 MSPS			ADS62P48/ADS62P28 210 MSPS			UNIT
		MIN	TYP	MAX	MIN	TYP	MAX	
<b>SFDR</b> Spurious Free Dynamic Range	Fin = 20 MHz		89			85		dBc
	Fin = 60 MHz		85			85		
	Fin = 100 MHz		78			80		
	Fin = 170 MHz	71	75		71	77		
	Fin = 230 MHz		77			72		
<b>SFDR</b> Spurious Free Dynamic Range, excluding HD2,HD3	Fin = 20 MHz		98			98		dBc
	Fin = 60 MHz		95			95		
	Fin = 100 MHz		92			92		
	Fin = 170 MHz	77	90		78	91		
	Fin = 230 MHz		90			90		
<b>HD2</b> Second Harmonic Distortion	Fin = 20 MHz		93			95		dBc
	Fin = 60 MHz		90			94		
	Fin = 100 MHz		90			90		
	Fin = 170 MHz	71	85		71	88		
	Fin = 230 MHz		85			80		
<b>HD3</b> Third Harmonic Distortion	Fin = 20 MHz		89			85		dBc
	Fin = 60 MHz		85			85		
	Fin = 100 MHz		78			80		
	Fin = 170 MHz	71	75		71	77		
	Fin = 230 MHz		77			72		
<b>THD</b> Total harmonic distortion	Fin = 20 MHz		87			83.5		dBc
	Fin = 60 MHz		83.5			84.6		
	Fin = 100 MHz		77.5			79.7		
	Fin = 170 MHz	70	74		70.5	76.5		
	Fin = 230 MHz		75			71		
<b>IMD</b> 2-Tone Inter-modulation Distortion	F1 = 46 MHz, F2 = 50 MHz, each tone at –7 dBFS		87			91		dBFS
	F1 = 185 MHz, F2 = 190 MHz, each tone at –7 dBFS		85			84.5		
Cross-talk	Up to 200-MHz cross-talk frequency		90			90		dB
Input overload recovery	Recovery to within 1% (of final value) for 6-dB overload with sine wave input		1			1		Clock Cycles
<b>PSRR</b> AC Power supply rejection ratio	For 100-mV pp signal on AVDD supply		25			25		dB

## DIGITAL CHARACTERISTICS — ADS62Px9/x8

The DC specifications refer to the condition where the digital outputs are not switching, but are permanently at a valid logic level 0 or 1. AVDD = 3.3V, DRVDD = 1.8V

PARAMETER		TEST CONDITIONS	ADS62P49/ADS62P48/ ADS62P29/ADS62P28			UNIT
			MIN	TYP	MAX	
<b>DIGITAL INPUTS – CTRL1, CTRL2, CTRL3, RESET, SCLK, SDATA, SEN<sup>(1)</sup></b>						
High-level input voltage		All digital inputs support 1.8V and 3.3V CMOS logic levels.	1.3			V
Low-level input voltage			0.4			V
High-level input current	SDATA, SCLK <sup>(2)</sup>	$V_{HIGH} = 3.3\text{ V}$	16			$\mu\text{A}$
	SEN <sup>(3)</sup>		10			
Low-level input current	SDATA, SCLK	$V_{LOW} = 0\text{ V}$	0			$\mu\text{A}$
	SEN		-20			
Input capacitance			4			pF
<b>DIGITAL OUTPUTS – CMOS INTERFACE (DA0-DA13, DB0-DB13, CLKOUT, SDOUT)</b>						
High-level output voltage		$I_{OH} = 1\text{ mA}$	DRVDD -0.1	DRVDD	V	
Low-level output voltage		$I_{OL} = 1\text{ mA}$	0	0.1	V	
Output capacitance (internal to device)			2			pF
<b>DIGITAL OUTPUTS – LVDS INTERFACE</b>						
$V_{ODH}$	High-level output differential voltage	With external 100 $\Omega$ termination.	275	350	425	mV
$V_{ODL}$	Low-level output differential voltage	With external 100 $\Omega$ termination.	-425	-350	-275	mV
$V_{OCM}$	Output common-mode voltage		1	1.15	1.4	V
Output Capacitance		Capacitance inside the device from each output to ground	2			pF

- (1) SCLK, SDATA, SEN function as digital input pins in serial configuration mode.  
 (2) SDATA, SCLK, RESET, CTRL1, CTRL2, and CTRL3 have an internal 100-k $\Omega$  pull-down resistor.  
 (3) SEN has internal 100 k $\Omega$  pull-up resistor to AVDD. Since the pull-up is weak, SEN can also be driven by 1.8V or 3.3V CMOS buffers.

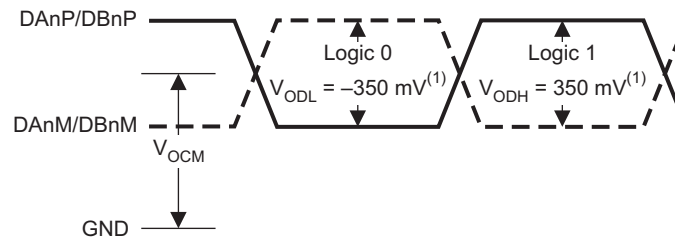

T0334-02

- (1) With external 100- $\Omega$  termination

**Figure 4. LVDS Output Voltage Levels**

## TIMING REQUIREMENTS – LVDS AND CMOS MODES<sup>(1)</sup>

Typical values are at 25°C, AVDD = 3.3V, DRVDD = 1.8V, sampling frequency = 250 MSPS, sine wave input clock, 1.5 Vpp clock amplitude, C<sub>LOAD</sub> = 5pF<sup>(2)</sup>, R<sub>LOAD</sub> = 100Ω<sup>(3)</sup>, (unless otherwise noted).

Min and max values are across the full temperature range T<sub>MIN</sub> = –40°C to T<sub>MAX</sub> = 85°C, AVDD = 3.3V, DRVDD = 1.7V to 1.9V

PARAMETER		TEST CONDITIONS	MIN	TYP	MAX	UNIT
t <sub>a</sub>	Aperture delay		0.7	1.2	1.7	ns
	Aperture delay matching	Between two channels within the same device		±50		ps
t <sub>j</sub>	Aperture jitter			145		fs rms
	Wake-up time	Time to valid data after coming out of STANDBY mode		1	3	μs
		Time to valid data after coming out of global powerdown		20	50	μs
		Time to valid data after stopping and restarting the input clock		10		Clock cycles
	ADC latency <sup>(4)</sup>			22		Clock cycles
<b>DDR LVDS MODE<sup>(5)</sup></b>						
t <sub>SU</sub>	Data setup time	Data valid <sup>(6)</sup> to zero-crossing of CLKOUTP	0.55	0.9		ns
t <sub>H</sub>	Data hold time	Zero-crossing of CLKOUTP to data becoming invalid <sup>(6)</sup>	0.55	0.95		ns
t <sub>PDI</sub>	Clock propagation delay	Input clock falling edge cross-over to output clock rising edge cross-over 100 MSPS ≤ Sampling frequency ≤ 250 MSPS Ts = 1/Sampling frequency	t <sub>PDI</sub> = 0.69 × Ts + t <sub>delay</sub>			
t <sub>delay</sub>			4.2	5.7	7.2	ns
	t <sub>delay</sub> skew	Difference in t <sub>delay</sub> between two devices operating at same temperature and DRVDD supply voltage		±500		ps
	LVDS bit clock duty cycle	Duty cycle of differential clock, (CLKOUTP-CLKOUTM) 100 MSPS ≤ Sampling frequency ≤ 250 MSPS		52%		
t <sub>RISE</sub> , t <sub>FALL</sub>	Data rise time, Data fall time	Rise time measured from –100mV to +100mV Fall time measured from +100mV to –100mV 1 MSPS ≤ Sampling frequency ≤ 250 MSPS		0.14		ns
t <sub>CLKRISE</sub> , t <sub>CLKFALL</sub>	Output clock rise time, Output clock fall time	Rise time measured from –100mV to +100mV Fall time measured from +100mV to –100mV 1 MSPS ≤ Sampling frequency ≤ 250 MSPS		0.14		ns
t <sub>OE</sub>	Output buffer enable to data delay	Time to valid data after output buffer becomes active		100		ns
<b>PARALLEL CMOS MODE<sup>(7)</sup> at Fs = 210 MSPS</b>						
t <sub>START</sub>	Input clock to data delay	Input clock falling edge cross-over to start of data valid <sup>(8)</sup>			2.5	ns
t <sub>DV</sub>	Data valid time	Time interval of valid data <sup>(8)</sup>	1.7	2.7		ns
t <sub>PDI</sub>	Clock propagation delay	Input clock falling edge cross-over to output clock rising edge cross-over 100 MSPS ≤ Sampling frequency ≤ 150 MSPS Ts = 1/Sampling frequency	t <sub>PDI</sub> = 0.28 × Ts + t <sub>delay</sub>			
t <sub>delay</sub>			5.5	7.0	8.5	ns
	Output clock duty cycle	Duty cycle of output clock, CLKOUT 100 MSPS ≤ Sampling frequency ≤ 150 MSPS		43%		
t <sub>RISE</sub> , t <sub>FALL</sub>	Data rise time, Data fall time	Rise time measured from 20% to 80% of DRVDD Fall time measured from 80% to 20% of DRVDD 1 ≤ Sampling frequency ≤ 210 MSPS		1.2		ns
t <sub>CLKRISE</sub> , t <sub>CLKFALL</sub>	Output clock rise time, Output clock fall time	Rise time measured from 20% to 80% of DRVDD Fall time measured from 80% to 20% of DRVDD 1 ≤ Sampling frequency ≤ 150 MSPS		0.8		ns

(1) Timing parameters are ensured by design and characterization and not tested in production

(2) C<sub>LOAD</sub> is the effective external single-ended load capacitance between each output pin and ground

(3) R<sub>LOAD</sub> is the differential load resistance between the LVDS output pair.

(4) At higher clock frequencies, t<sub>PDI</sub> is greater than one clock period and overall latency = ADC latency + 1.

(5) Measurements are done with a transmission line of 100Ω characteristic impedance between the device and the load. Setup and hold time specifications take into account the effect of jitter on the output data and clock.

(6) Data valid refers to LOGIC HIGH of +100.0mV and LOGIC LOW of –100.0mV.

(7) For Fs > 150 MSPS, it is recommended to use external clock for data capture and NOT the device output clock signal (CLKOUT).

(8) Data valid refers to LOGIC HIGH of 1.26V and LOGIC LOW of 0.54V.

**TIMING REQUIREMENTS – LVDS AND CMOS MODES<sup>(1)</sup> (continued)**

Typical values are at 25°C, AVDD = 3.3V, DRVDD = 1.8V, sampling frequency = 250 MSPS, sine wave input clock, 1.5 Vpp clock amplitude, C<sub>LOAD</sub> = 5pF<sup>(2)</sup>, R<sub>LOAD</sub> = 100Ω<sup>(3)</sup>, (unless otherwise noted).

Min and max values are across the full temperature range T<sub>MIN</sub> = -40°C to T<sub>MAX</sub> = 85°C, AVDD = 3.3V, DRVDD = 1.7V to 1.9V

PARAMETER	TEST CONDITIONS	MIN	TYP	MAX	UNIT
t <sub>OE</sub> Output buffer enable (OE) to data delay <sup>(9)</sup>	Time to valid data after output buffer becomes active		100		ns

(9) Output buffer enable is controlled by Serial Interface Register 0x40. The output buffer becomes active once serial control data for output buffer is latched in on the 16th SCLK falling edge when SEN is low.

**Table 2. LVDS Timings at Lower Sampling Frequencies**

Sampling Frequency, MSPS	Setup Time, ns			Hold Time, ns		
	MIN	TYP	MAX	MIN	TYP	MAX
210	0.75	1.1		0.75	1.15	
185	0.9	1.25		0.85	1.25	
153	1.15	1.55		1.1	1.5	
125	1.6	2		1.45	1.85	
< 100 (Enable LOW SPEED mode for Fs ≤ 80) <sup>(1)</sup>	2			2		
1 ≤ Fs ≤ 100 (Enable LOW SPEED mode for Fs ≤ 80) <sup>(1)</sup>				t <sub>PDI</sub> , ns		
				MIN	TYP	MAX
					12.6	

(1) LOW SPEED mode can be enabled with serial interface configuration only.

**Table 3. CMOS Timings at Lower Sampling Frequencies**

Sampling Frequency, MSPS	Timings Specified With Respect to Input Clock					
	t <sub>START</sub> , ns			Data Valid time, ns		
	MIN	TYP	MAX	MIN	TYP	MAX
210			2.5	1.7	2.7	
190			1.9	2	3	
170			0.9	2.7	3.7	
150			6	3.6	4.6	
Sampling Frequency, MSPS	Timings Specified With Respect to CLKOUT					
	Setup Time, ns			Hold Time, ns		
	MIN	TYP	MAX	MIN	TYP	MAX
170	2.1	3.7		0.35	1.0	
150	2.8	4.4		0.5	1.2	
125	3.8	5.4		0.8	1.5	
<100 (Enable LOW SPEED mode for Fs ≤ 80) <sup>(1)</sup>	5			1.2		
1 ≤ Fs ≤ 100 (Enable LOW SPEED mode for Fs ≤ 80) <sup>(1)</sup>				t <sub>PDI</sub> , ns		
				MIN	TYP	MAX
					9	

(1) LOW SPEED mode can be enabled with serial interface configuration only.

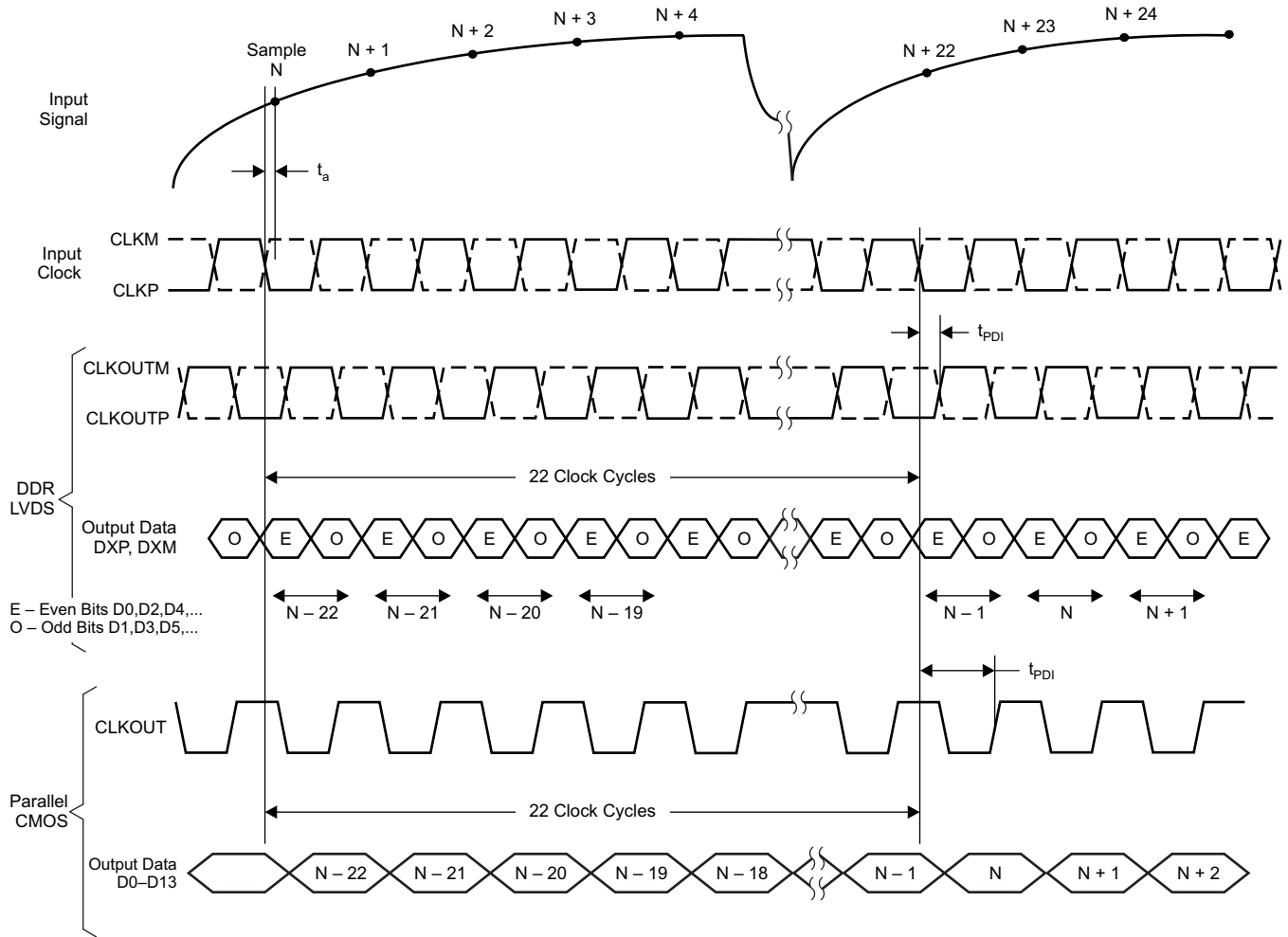

T0105-11

Figure 5. Latency Diagram

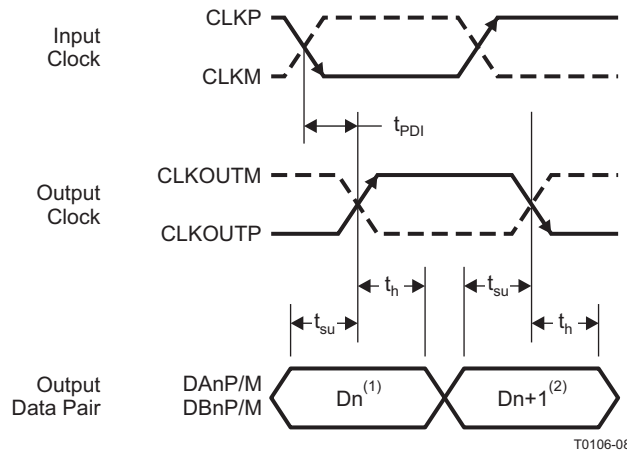

T0106-08

- (1) Dn - Bits D0, D2, D4, ...
- (2) Dn + 1 - Bits D1, D3, D5, ...

Figure 6. LVDS Interface Timing

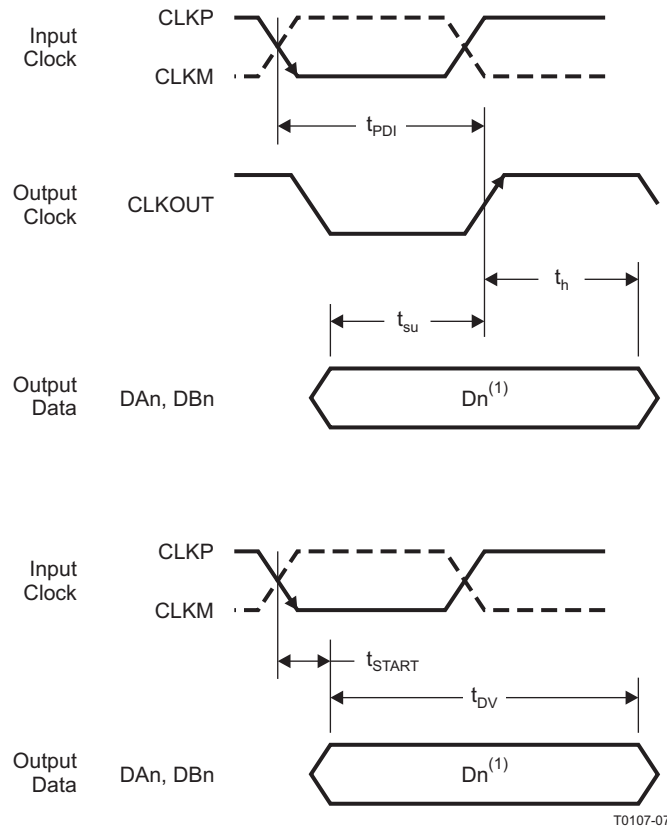

T0107-07

(1) Dn - Bits D0, D1, D2, ... of Channel A and B

**Figure 7. CMOS Interface Timing**

## DEVICE CONFIGURATION

ADS62Px9/x8 can be configured independently using either parallel interface control or serial interface programming.

### PARALLEL CONFIGURATION ONLY

To put the device in parallel configuration mode, keep RESET tied to **high** (AVDD or DRVDD).

Now, pins SEN, SCLK, CTRL1, CTRL2 and CTRL3 can be used to directly control certain modes of the ADC. The device can be easily configured by connecting the parallel pins to the correct voltage levels (as described in [Table 4](#) to [Table 7](#)). There is no need to apply reset and SDATA pin can be connected to ground.

In this mode, SEN and SCLK function as parallel interface control pins. Frequently used functions can be controlled in this mode – power down modes, internal/external reference, selection between LVDS/CMOS interface and output data format.

[Table 4](#) has a brief description of the modes controlled by the four parallel pins.

**Table 4. Parallel Pin Definition**

PIN	TYPE OF PIN	CONTROLS MODES
SCLK	Analog control pins (controlled by analog voltage levels, see <a href="#">Figure 8</a> )	Internal/external reference
SEN		LVDS/CMOS interface and output data format
CTRL1	Digital control pins (controlled by digital logic levels)	Controls power down modes
CTRL2		
CTRL3		

### SERIAL INTERFACE CONFIGURATION ONLY

To exercise this mode, first the serial registers have to be reset to their default values and RESET pin has to be kept **low**.

SEN, SDATA and SCLK function as serial interface pins in this mode and can be used to access the internal registers of the ADC.

The registers can be reset either by applying a pulse on RESET pin or by setting the <RESET> bit **high**. The serial interface section describes the register programming and register reset in more detail

### DETAILS OF PARALLEL CONFIGURATION ONLY

The functions controlled by each parallel pin are described below. A simple way of configuring the parallel pins is shown in [Figure 8](#).

**Table 5. SCLK CONTROL PIN**

VOLTAGE APPLIED ON SCLK	DESCRIPTION
0 +200mV/-0mV	Internal reference
(3/8)AVDD +/- 200mV	External reference
(5/8) AVDD +/- 200mV	External reference
AVDD +0mV/-200mV	Internal reference

**Table 6. SEN CONTROL PIN**

VOLTAGE APPLIED ON SEN	DESCRIPTION
0 (+200mV/-0mV)	2's complement, DDR LVDS output
(3/8)AVDD ( $\pm 200$ mV)	Offset binary, DDR LVDS output
(5/8)AVDD ( $\pm 200$ mV)	Offset binary, parallel CMOS output
AVDD (+0mV/-200mV)	2's compliment, parallel CMOS output

**Table 7. CTRL1, CTRL2 and CTRL3 PINS <sup>(1)</sup>**

CTRL1	CTRL2	CTRL3	DESCRIPTION
LOW	LOW	LOW	Normal operation
LOW	LOW	HIGH	Not available
LOW	HIGH	LOW	Not available
LOW	HIGH	HIGH	Not available
HIGH	LOW	LOW	Global power down
HIGH	LOW	HIGH	Channel B standby
HIGH	HIGH	LOW	Channel A standby
HIGH	HIGH	HIGH	MUX mode of operation, Channel A and B data is multiplexed and output on <b>DA13 to DA0</b> pins. <sup>(2)</sup>

(1) See **POWER DOWN** in the APPLICATION INFORMATION section.

(2) Low Speed mode has to be enabled for Multiplexed Output mode (MUX mode). Therefore, MUX mode works with serial interface configuration only and is not supported with parallel configuration.

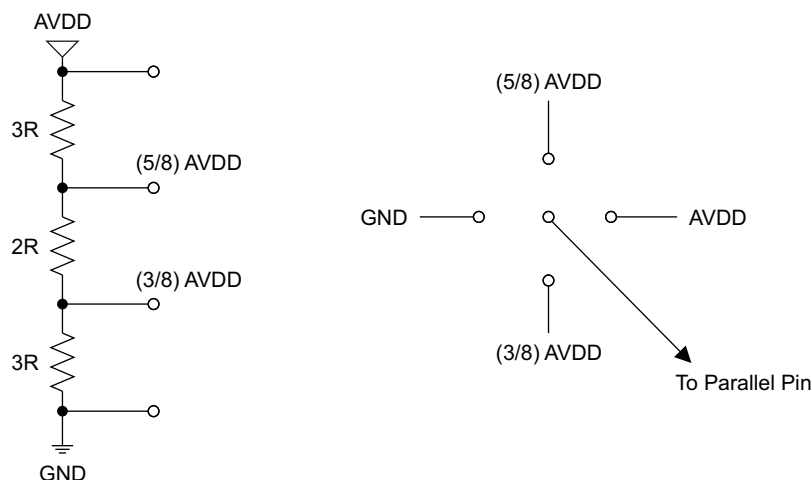

S0321-01

**Figure 8. Simple Scheme to Configure Parallel Pins**

## USING BOTH SERIAL INTERFACE AND PARALLEL CONTROLS

For increased flexibility, a combination of serial interface registers and parallel pin controls (CTRL1 to CTRL3) can also be used to configure the device. To allow this, keep RESET low. The parallel interface control pins CTRL1 to CTRL3 are available. After power-up, the device is automatically configured as per the voltage settings on these pins (see Table 6). SEN, SDATA, and SCLK function as serial interface digital pins and are used to access the internal registers of ADC. The registers must first be reset to their default values either by applying a pulse on RESET pin or by setting bit <RST> = 1. After reset, the RESET pin must be kept low. The Serial Interface section describes register programming and register reset in more detail.

## SERIAL INTERFACE

The ADC has a set of internal registers, which can be accessed by the serial interface formed by pins SEN (Serial interface Enable), SCLK (Serial Interface Clock) and SDATA (Serial Interface Data).

Serial shift of bits into the device is enabled when SEN is low. Serial data SDATA is latched at every falling edge of SCLK when SEN is active (low). The serial data is loaded into the register at every 16<sup>th</sup> SCLK falling edge when SEN is low. In case the word length exceeds a multiple of 16 bits, the excess bits are ignored. Data can be loaded in multiple of 16-bit words within a single active SEN pulse.

The first 8 bits form the register address and the remaining 8 bits are the register data. The interface can work with SCLK frequency from 20 MHz down to very low speeds (few Hertz) and also with non-50% SCLK duty cycle.

### Register Initialization

After power-up, the internal registers MUST be initialized to their default values. This can be done in one of two ways:

1. Either through hardware reset by applying a high-going pulse on RESET pin (of width greater than 10ns) as shown in [Figure 9](#)

OR

2. By applying software reset. Using the serial interface, set the **<RESET>** bit (D7 in register 0x00) to HIGH. This initializes internal registers to their default values and then self-resets the **<RESET>** bit to **low**. In this case the RESET pin is kept **low**.

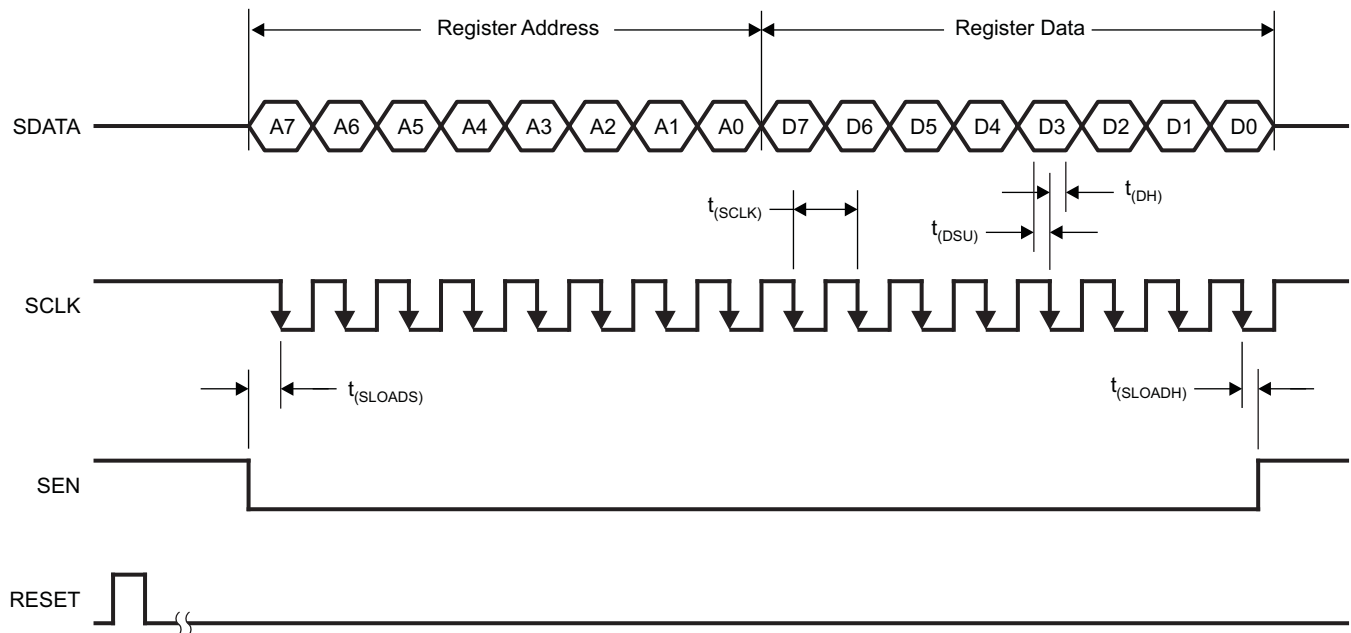

T0109-01

**Figure 9. Serial Interface Timing**

## SERIAL INTERFACE TIMING CHARACTERISTICS

Typical values at 25°C, min and max values across the full temperature range  $T_{MIN} = -40^{\circ}C$  to  $T_{MAX} = 85^{\circ}C$ ,  $AVDD = 3.3V$ ,  $DRVDD = 1.8V$  (unless otherwise noted).

PARAMETER		MIN	TYP	MAX	UNIT
$f_{SCLK}$	SCLK frequency (= $1/t_{SCLK}$ )	> DC		20	MHz
$t_{SLOADS}$	SEN to SCLK setup time	25			ns
$t_{SLOADH}$	SCLK to SEN hold time	25			ns
$t_{DS}$	SDATA setup time	25			ns
$t_{DH}$	SDATA hold time	25			ns

### Serial Register Readout

The device includes an option where the contents of the internal registers can be read back. This may be useful as a diagnostic check to verify the serial interface communication between the external controller AND the ADC.

- First, set register bit <SERIAL READOUT> = 1. This also disables any further writes into the registers.
- Initiate a serial interface cycle specifying the address of the register (A7-A0) whose content has to be read.
- The device outputs the contents (D7-D0) of the selected register on the SDOUT pin (64).
- The external controller can latch the contents at the falling edge of SCLK.
- To enable register writes, reset register bit <SERIAL READOUT> = 0. SDOUT is a CMOS output pin; the readout functionality is available whether the ADC output data interface is LVDS or CMOS.

When <SERIAL READOUT> is disabled, the SDOUT pin is forced low by the device (and not put in high-impedance). If serial readout is not used, the SDOUT pin has to be floated.

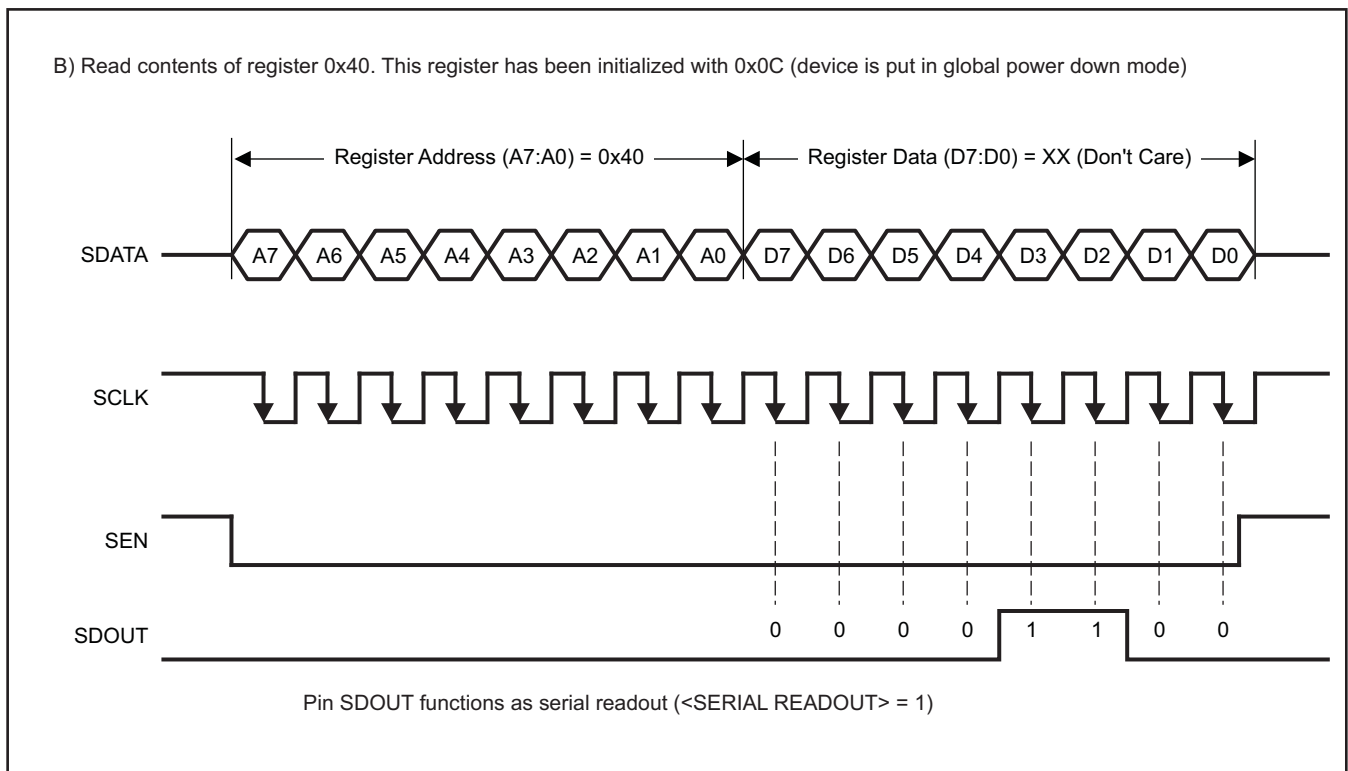
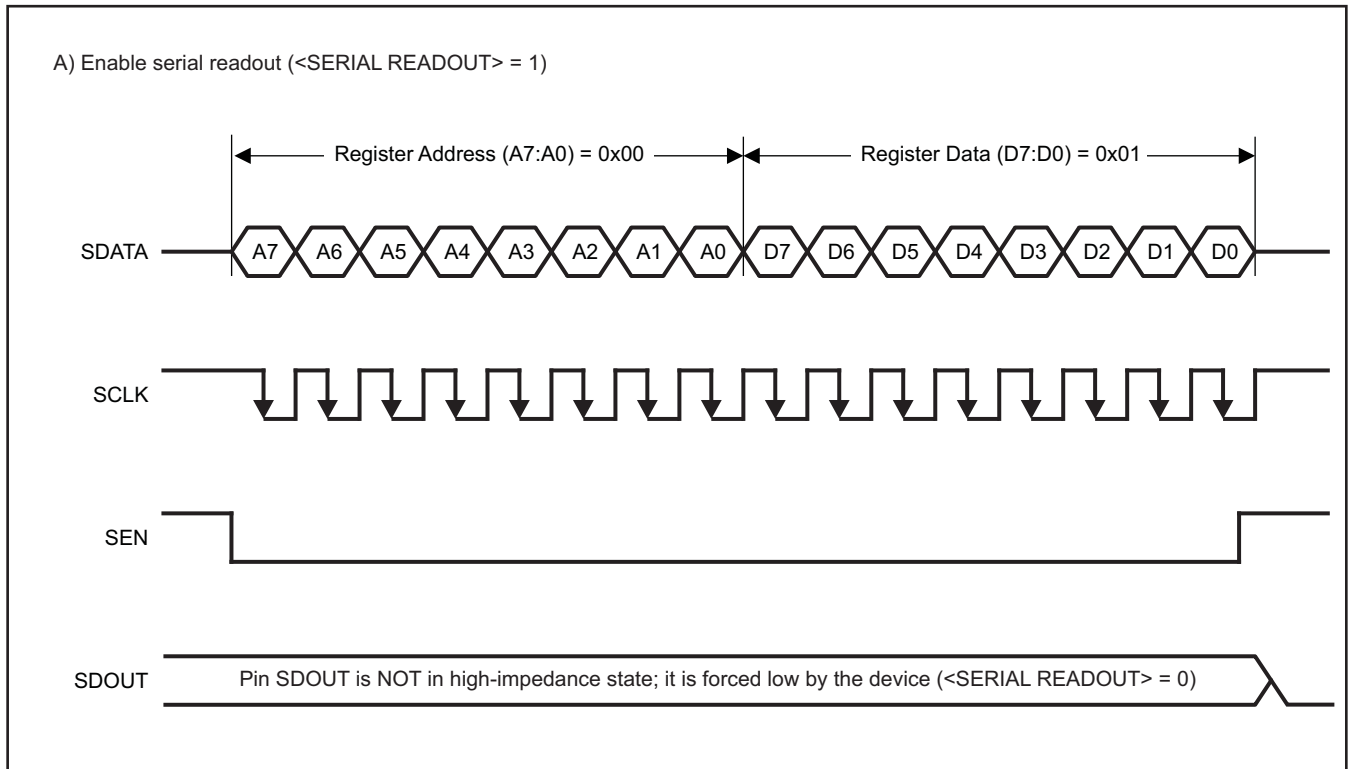

T0386-02

Figure 10. Serial Readout

## RESET TIMING (ONLY WHEN SERIAL INTERFACE IS USED)

Typical values at 25°C, min and max values across the full temperature range  $T_{MIN} = -40^{\circ}C$  to  $T_{MAX} = 85^{\circ}C$  (unless otherwise noted).

PARAMETER	CONDITIONS	MIN	TYP	MAX	UNIT
$t_1$ Power-on delay	Delay from power-up of AVDD and DRVDD to RESET pulse active	1			ms
$t_2$ Reset pulse width	Pulse width of active RESET signal	10			ns
				1 <sup>(1)</sup>	$\mu$ s
$t_3$ Register write delay	Delay from RESET disable to SEN active	100			ns

- (1) The reset pulse is needed only when using the serial interface configuration. If the pulse width is greater than 1 $\mu$ sec, the device could enter the parallel configuration mode briefly and then return back to serial interface mode.

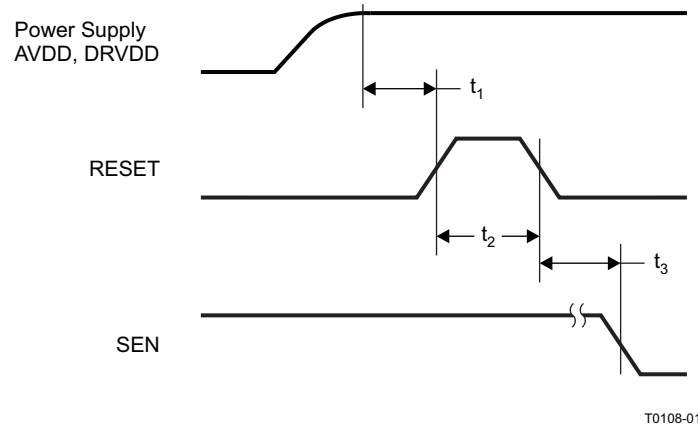

T0108-01

NOTE: A high-going pulse on RESET pin is required in serial interface mode in case of initialization through hardware reset. For parallel interface operation, RESET has to be tied permanently HIGH.

Figure 11. Reset Timing Diagram

**SERIAL REGISTER MAP**
**Table 8. Summary of Functions Supported by Serial Interface <sup>(1)</sup>**

REGISTER ADDRESS	REGISTER FUNCTIONS							
	D7	D6	D5	D4	D3	D2	D1	D0
A7-A0 IN HEX								
00	<RESET> <i>Software Reset</i>	0	0	0	0	0	0	<SERIAL READOUT>
20	0	0	0	0	0	<ENABLE LOW SPEED MODE>	0	0
3F	0	<REF> <i>Internal or external reference</i>	0	0	0	0	<STANDBY>	0
40	0	0	0	0	<POWER DOWN MODES>			
41	<LVDS CMOS> <i>Output interface</i>	0	0	0	0	0	0	0
44	<CLKOUT EDGE CONTROL>						0	0
50	0	<ENABLE INDIVIDUAL CHANNEL CONTROL>	0	0	0	<DATA FORMAT> <i>2s comp or offset binary</i>	0	
51	<CUSTOM PATTERN LOW>							
52	0	0	<CUSTOM PATTERN HIGH>					
53	0	<ENABLE OFFSET CORRECTION – CH A>	0					
55	<GAIN PROGRAMMABILITY – CH A> <i>0 to 6 dB in 0.5 dB steps</i>				<OFFSET CORRECTION TIME CONSTANT – CH A>			
57	0	<FINE GAIN ADJUST – CH A> <i>+0.001 dB to +0.134 dB, in 128 steps</i>						
62	0	0	0	0	0	<TEST PATTERNS – CH A>		
63	0	0	<OFFSET PEDESTAL – CH A>					
66	0	<ENABLE OFFSET CORRECTION – CH B>	0	0	0	0	0	0
68	<GAIN PROGRAMMABILITY – CH B> <i>0 to 6 dB in 0.5 dB steps</i>				<OFFSET CORRECTION TIME CONSTANT – CH B>			
6A	0	<FINE GAIN ADJUST – CH B> <i>+0.001 dB to +0.134 dB, in 128 steps</i>						
75	0	0	0	0	0	<TEST PATTERNS – CH B>		
76	0	0	<OFFSET PEDESTAL – CH B>					

(1) Multiple functions in a register can be programmed in a single write operation.

## DESCRIPTION OF SERIAL REGISTERS

A7-A0 IN HEX	D7	D6	D5	D4	D3	D2	D1	D0
00	<RESET> <i>Software Reset</i>	0	0	0	0	0		<SERIAL READOUT>

### D7 <RESET>

- 1 Software reset applied – resets all internal registers and self-clears to 0.

### D0 <SERIAL READOUT>

- 0 Serial readout disabled. SDOOUT is forced low by the device (and not put in high impedance state).
- 1 Serial readout enabled, Pin SDOOUT functions as serial data readout.

A7-A0 IN HEX	D7	D6	D5	D4	D3	D2	D1	D0
20	0	0	0	0	0	<ENABLE LOW SPEED MODE>	0	0

### D2 <ENABLE LOW SPEED MODE>

- 0 LOW SPEED mode disabled. Use for sampling frequency > 80 MSPS
- 1 Enable LOW SPEED mode for sampling frequencies ≤ 80 MSPS.

A7-A0 IN HEX	D7	D6	D5	D4	D3	D2	D1	D0
3F	0	<REF>		0	0	0	<STANDBY>	0

### D6-D5 <REF> Internal or external reference selection

- 00 Internal reference enabled
- 01
- 10
- 11 External reference enabled

### D1 <STANDBY>

- 0 Normal operation
- 1 Both ADC channels are put in standby. Internal references, output buffers are active. This results in quick wake-up time from standby.

A7-A0 IN HEX	D7	D6	D5	D4	D3	D2	D1	D0
40	0	0	0	0	POWER DOWN MODES			

### D3-D0 <POWER DOWN MODES>

- 0000 Pins CTRL1, CTRL2, and CTRL3 determine power down modes.
- 1000 Normal operation
- 1001 Output buffer disabled for channel B
- 1010 Output buffer disabled for channel A
- 1011 Output buffer disabled for channel A and B
- 1100 Global power down
- 1101 Channel B standby
- 1110 Channel A standby
- 1111 Multiplexed mode, **MUX-** (only with CMOS interface)  
Channel A and B data is multiplexed and output on **DA13 to DA0** pins. Refer to the [Multiplexed Output Mode](#) section in the APPLICATION INFORMATION for additional information.

A7-A0 IN HEX	D7	D6	D5	D4	D3	D2	D1	D0
41	<LVDS CMOS>	0	0	0	0	0	0	0

**D7 <LVDS CMOS>**

- 0 Parallel CMOS interface
- 1 DDR LVDS interface

A7-A0 IN HEX	D7	D6	D5	D4	D3	D2	D1	D0
44	<CLKOUT EDGE CONTROL> <i>Output clock edge control</i>						0	0

**LVDS interface**
**D7-D5 <CLKOUT POSN> Output clock rising edge position <sup>(2)</sup>**

- 000, 100 Default output clock position (refer to timing specification table)
- 101 Falling edge shifted (delayed) by + (4/26)×Ts<sup>(1)</sup>
- 110 Falling edge shifted (advanced) by – (7/26)×Ts
- 111 Falling edge shifted (advanced) by – (4/26)×Ts

**D4-D2 <CLKOUT POSN> Output clock falling edge position <sup>(2)</sup>**

- 000, 100 Default output clock position (refer to timing specification table)
- 101 Rising edge shifted (delayed) by + (4/26)×Ts
- 110 Rising edge shifted (advanced) by – (7/26)×Ts
- 111 Rising edge shifted (advanced) by – (4/26)×Ts

**CMOS interface**
**D7-D5 <CLKOUT POSN> Output clock rising edge position <sup>(2)</sup>**

- 000, 100 Default output clock position (refer to timing specification table)
- 101 Rising edge shifted (delayed) by + (4/26)×Ts
- 110 Rising edge shifted (advanced) by – (7/26)×Ts
- 111 Rising edge shifted (advanced) by – (4/26)×Ts

**D4-D2 <CLKOUT POSN> Output clock falling edge position <sup>(2)</sup>**

- 000, 100 Default output clock position (refer to timing specification table)
- 101 Falling edge shifted (delayed) by + (4/26)×Ts
- 110 Falling edge shifted (advanced) by – (7/26)×Ts
- 111 Falling edge shifted (advanced) by – (4/26)×Ts

<sup>(1)</sup> Ts = 1 / sampling frequency

<sup>(2)</sup> Keep the same duty cycle, move both edges by the same amount (i.e., write both D<4:2> and D<7:5> to be the same value).

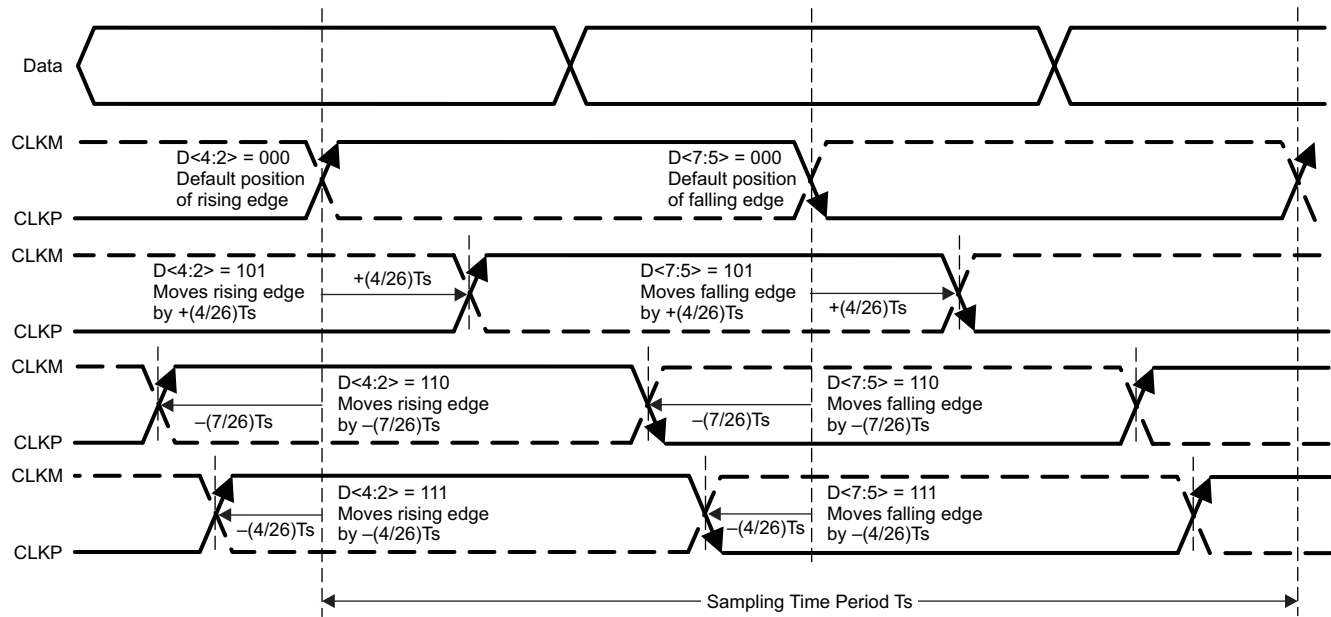

T0490-01

- NOTES: 1. Keep the same duty cycle, move both edges by same amount (i.e. write both D<4:2> and D<7:5> to be the same value).  
2. Refer to timing specification table for default output clock position.

**Figure 12. LVDS Interface Output Clock Edge Movement (Serial Register 0x44)**

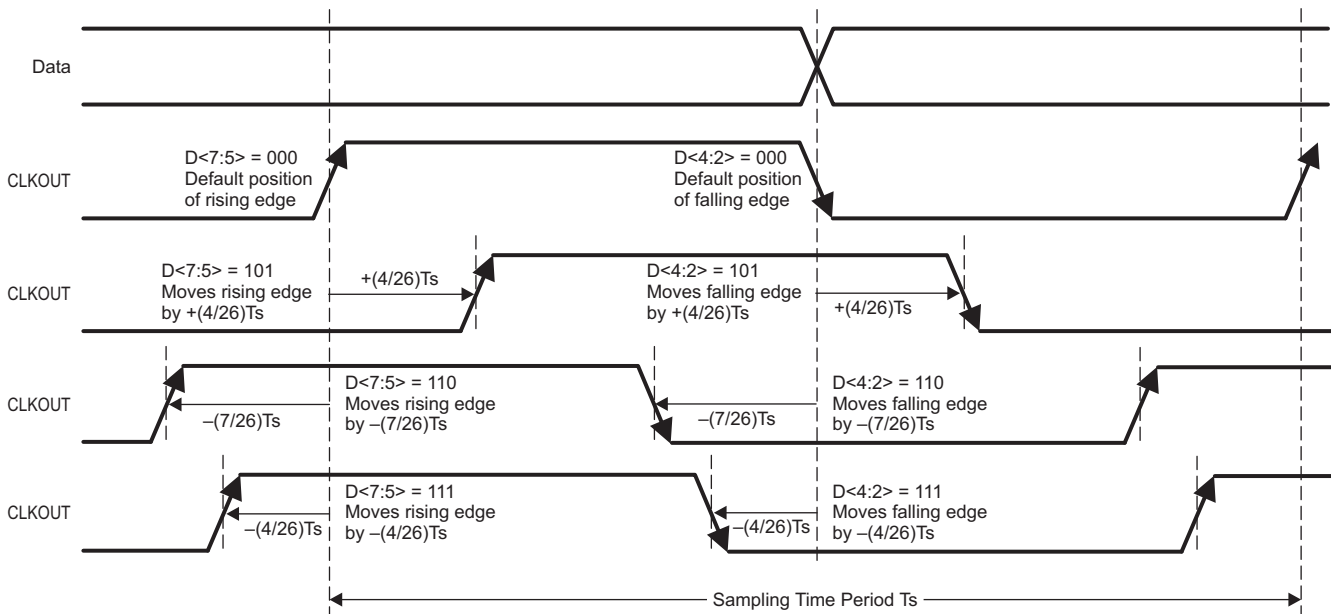

T0491-01

- NOTES: 1. Keep the same duty cycle, move both edges by same amount (i.e. write both D<4:2> and D<7:5> to be the same value).  
2. Refer to timing specification table for default output clock position.

**Figure 13. CMOS Interface Output Clock Edge Movement (Serial Register 0x44)**

A7-A0 IN HEX	D7	D6	D5	D4	D3	D2	D1	D0
50	0	<ENABLE INDEPENDENT CHANNEL CONTROL>	0	0	0	<DATA FORMAT> <i>2s complement or offset binary</i>		0

**D6 <ENABLE INDEPENDENT CHANNEL CONTROL>**

- 0 **Common control** – both channels use common control settings for test patterns, offset correction, fine gain, gain correction and SNR Boost functions. These settings can be specified in a single set of registers.
- 1 **Independent control** – both channels can be programmed with independent control settings for test patterns, offset correction and SNR Boost functions. Separate registers are available for each channel.

**D2-D1 <DATA FORMAT>**

- 10 2s complement
- 11 Offset binary

A7-A0 IN HEX	D7	D6	D5	D4	D3	D2	D1	D0
51	<Custom Pattern Low>							
52	0	0	<Custom Pattern High>					

**D7-D0 <CUSTOM PATTERN LOW>**

8 lower bits of custom pattern available at the output instead of ADC data.

**D5-D0 <CUSTOM PATTERN HIGH>**

6 upper bits of custom pattern available at the output instead of ADC data

Use this mode along with “Test Patterns” (register 0x62).

A7-A0 IN HEX	D7	D6	D5	D4	D3	D2	D1	D0
53	0	<ENABLE OFFSET CORRECTION – Common/Ch A> <i>Offset correction enable</i>	0	0	0	0	0	0

**D6 <ENABLE OFFSET CORRECTION – Common/Ch A>**

Offset correction enable control for both channels (*with common control*) or for channel A only (*with independent control*).

- 0 Offset correction disabled
- 1 Offset correction enabled

A7-A0 IN HEX	D7	D6	D5	D4	D3	D2	D1	D0
55	<GAIN – Common/Ch A>				<OFFSET CORR TIME CONSTANT – Common/Ch A> <i>Offset correction time constant</i>			

**D7-D4 <GAIN – Common/Ch A>**

Gain control for both channels (with common control) or for channel A only (with independent control).

- 0000 0 dB gain, default after reset
- 0001 0.5 dB gain
- 0010 1.0 dB gain
- 0011 1.5 dB gain
- 0100 2.0 dB gain
- 0101 2.5 dB gain
- 0110 3.0 dB gain
- 0111 3.5 dB gain
- 1000 4.0 dB gain
- 1001 4.5 dB gain
- 1010 5.0 dB gain
- 1011 5.5 dB gain
- 1100 6.0 dB gain

**D3-D0 <OFFSET CORR TIME CONSTANT – Common/Ch A>**

Correction loop time constant in number of clock cycles.

Applies to both channels (with common control) or for channel A only (with independent control).

- 0000 256 k
- 0001 512 k
- 0010 1 M
- 0011 2 M
- 0100 4 M
- 0101 8 M
- 0110 16 M
- 0111 32 M
- 1000 64 M
- 1001 128 M
- 1010 256 M
- 1011 512 M

A7-A0 IN HEX	D7	D6	D5	D4	D3	D2	D1	D0
57	0	<b>&lt;FINE GAIN ADJUST – Common/Ch A&gt;</b> +0.001 dB to +0.134 dB, in 128 steps						

Using the FINE GAIN ADJUST register bits, the channel gain can be trimmed in fine steps. The trim is only additive, has 128 steps and a range of 0.134dB. The relation between the FINE GAIN ADJUST bits and the trimmed channel gain is:

$$\Delta \text{ Channel gain} = 20 * \log_{10}[1 + (\text{FINE GAIN ADJUST}/8192)]$$

Note that the total device gain = ADC gain +  $\Delta$  Channel gain. The ADC gain is determined by register bits <GAIN PROGRAMMABILITY>

A7-A0 IN HEX	D7	D6	D5	D4	D3	D2	D1	D0
62	0	0	0	0	0	<b>&lt;TEST PATTERNS&gt;</b>		

**D2-D0 <TEST PATTERNS>** Test Patterns to verify data capture.

Applies to both channels (*with common control*) or for channel A only (*with independent control*).

- 000 Normal operation
- 001 Outputs all zeros
- 010 Outputs all ones
- 011 Outputs toggle pattern – see [Figure 14](#) and [Figure 15](#) for test pattern timing diagrams for LVDS and CMOS modes.  
 In ADS62P49/48, output data <D13:D0> alternates between 010101010101 and 101010101010 every clock cycle.  
 In ADS62P29/28, output data <D11:D0> alternates between 010101010101 and 101010101010 every clock cycle.
- 100 Outputs digital ramp  
 In ADS62P49/48, output data increments by one LSB (14-bit) every clock cycle from code 0 to code 16383  
 In ADS62P29/28, output data increments by one LSB (12-bit) every 4th clock cycle from code 0 to code 4095
- 101 Outputs custom pattern (use registers 0x51, 0x52 for setting the custom pattern), see [Figure 16](#) for an example of a custom pattern.
- 110 Unused
- 111 Unused

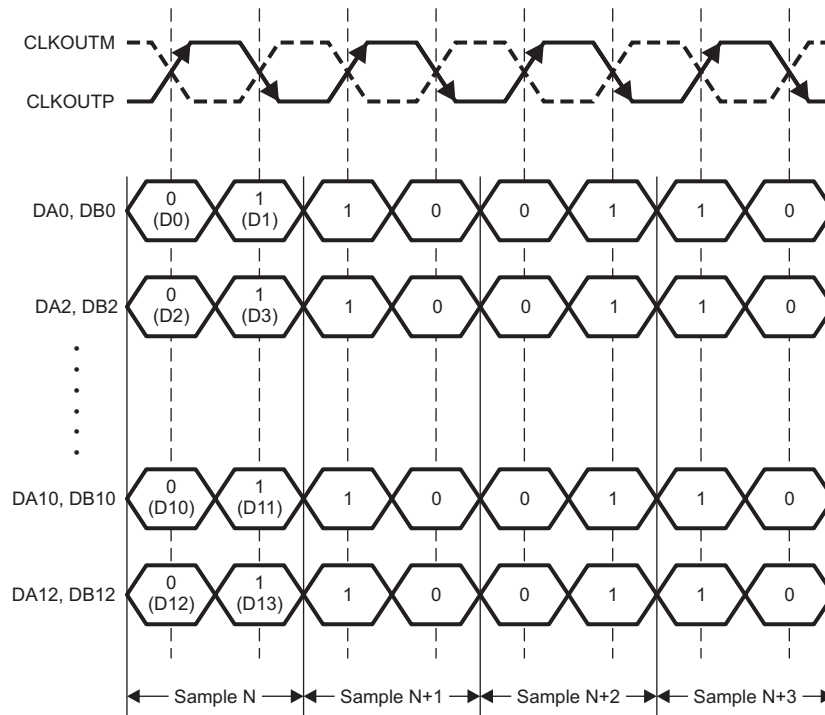

T0485-01

- NOTES: 1. Even bits output at the rising edge of CLKOUTP, and odd bits output at falling edge of CLKOUTP.  
 2. Output toggles at half the sampling rate ( $F_s/2$ ) in this test mode.

**Figure 14. Output Toggle Pattern (Serial Register 0x62, D<2:0> = 011) in LVDS Mode**

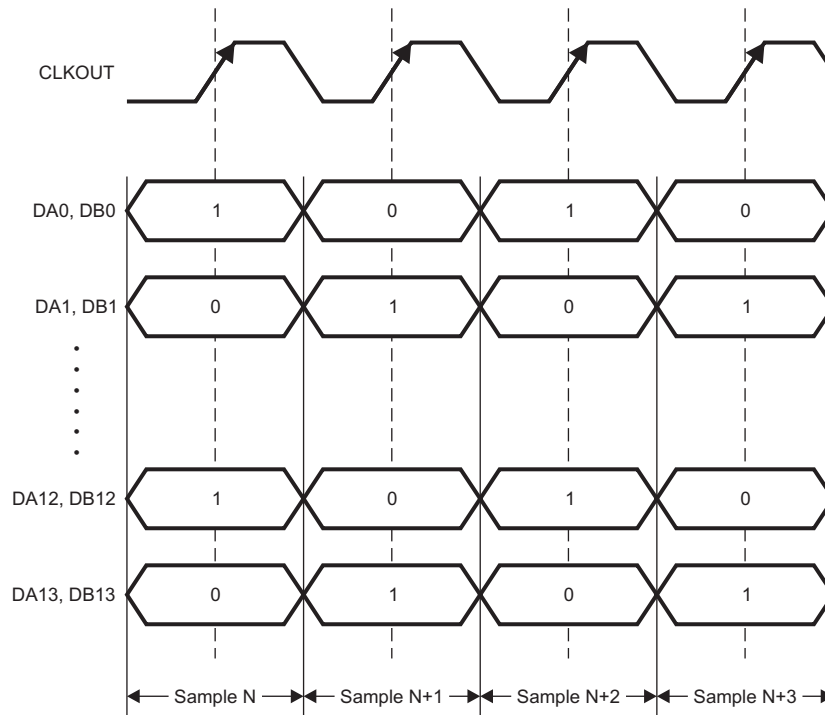

T0486-01

NOTE: Output toggles at half the sampling rate ( $F_s/2$ ) in this test mode.

**Figure 15. Output Toggle Pattern (Serial Register 0x62, D<2:0> = 011) in CMOS Mode**

**Example: Register 0x51 = 0xAA and Register 0x52 = 0x2A to toggle output at Fs**

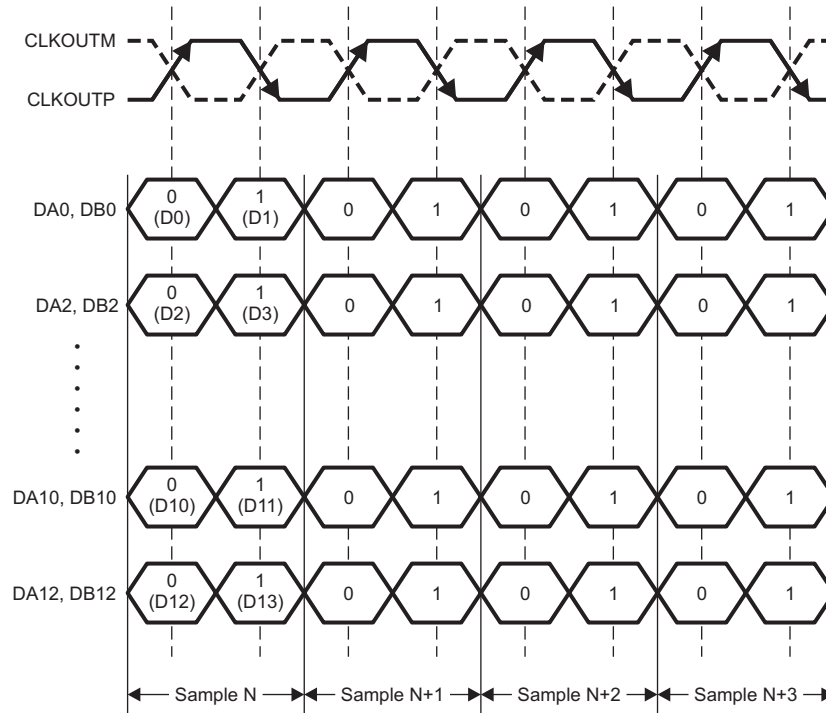

T0485-02

- NOTES: 1. Even bits output at the rising edge of CLKOUTP, and odd bits output at falling edge of CLKOUTP.  
 2. Output toggles at the sampling rate ( $F_s$ ) in this test mode.

**Figure 16. Output Custom Pattern (Serial Register 0x62, D<2:0> = 101) in LVDS Mode**

A7-A0 IN HEX	D7	D6	D5	D4	D3	D2	D1	D0
63	0	0	<b>&lt;OFFSET PEDESTAL – Common/Ch A&gt;</b>					

**D5-D0 <OFFSET PEDESTAL – Common/Ch A>**

When the offset correction is enabled, the final converged value (after the offset is corrected) will be the ideal ADC mid-code value (=8192 for P49/48, = 2048 for P29/28). A pedestal can be added to the final converged value by programming these bits. So, the final converged value will be = ideal mid-code + PEDESTAL.

See "Offset Correction" in application section.

Applies to both channels (*with common control*) or for channel A only (*with independent control*).

011111 PEDESTAL = 31 LSB

011110 PEDESTAL = 30 LSB

011101 PEDESTAL = 29 LSB

....

000000 PEDESTAL = 0

....

111111 PEDESTAL = –1 LSB

111110 PEDESTAL = –2 LSB

....

100000 PEDESTAL = –32 LSB

A7-A0 IN HEX	D7	D6	D5	D4	D3	D2	D1	D0
66	0	<b>&lt;ENABLE OFFSET CORRECTION – CH B&gt;</b> <i>Offset correction enable</i>	0	0	0	0	0	0

**D6 <ENABLE OFFSET CORRECTION – CH B>**

Offset correction enable control for channel B (only with independent control).

0 offset correction disabled

1 offset correction enabled

A7-A0 IN HEX	D7	D6	D5	D4	D3	D2	D1	D0
68	<GAIN – CH B>				<OFFSET CORR TIME CONSTANT – CH B> <i>Offset correction time constant</i>			

**D7-D4**      **<GAIN – CH B>** Gain programmability to 0.5 dB steps.

Applies to channel B (*only with independent control*).

0000	0 dB gain, default after reset
0001	0.5 dB gain
0010	1.0 dB gain
0011	1.5 dB gain
0100	2.0 dB gain
0101	2.5 dB gain
0110	3.0 dB gain
0111	3.5 dB gain
1000	4.0 dB gain
1001	4.5 dB gain
1010	5.0 dB gain
1011	5.5 dB gain
1100	6.0 dB gain

**D3-D0**      **<OFFSET CORR TIME CONSTANT – CH B>** Time constant of correction loop in number of clock cycles.

Applies to channel B (*only with independent control*).

0000	256 k
0001	512 k
0010	1 M
0011	2 M
0100	4 M
0101	8 M
0110	16 M
0111	32 M
1000	64 M
1001	128 M
1010	256 M
1011	512 M

A7-A0 IN HEX	D7	D6	D5	D4	D3	D2	D1	D0
6A								

**<FINE GAIN ADJUST – CH B>**  
+0.001 dB to +0.134 dB, in 128 steps

Using the FINE GAIN ADJUST register bits, the channel gain can be trimmed in fine steps. The trim is only additive, has 128 steps and a range of 0.134dB. The relation between the FINE GAIN ADJUST bits and the trimmed channel gain is:

$$\Delta \text{ Channel gain} = 20 * \log_{10}[1 + (\text{FINE GAIN ADJUST}/8192)]$$

Note that the total device gain = ADC gain +  $\Delta$  Channel gain. The ADC gain is determined by register bits <GAIN PROGRAMMABILITY>

A7-A0 IN HEX	D7	D6	D5	D4	D3	D2	D1	D0
75			0	0	0			

**<TEST PATTERNS – CH B>**

**D2-D0**     **<TEST PATTERNS>** Test Patterns to verify data capture.

Applies to channel B (only with independent control)

- 000 Normal operation
- 001 Outputs all zeros
- 010 Outputs all ones
- 011 Outputs toggle pattern – see [Figure 14](#) and [Figure 15](#) for LVDS and CMOS modes.  
In ADS62P49/48, output data <D13:D0> alternates between 010101010101 and 101010101010 every clock cycle.  
In ADS62P29/28, output data <D11:D0> alternates between 010101010101 and 101010101010 every clock cycle.
- 100 Outputs digital ramp  
In ADS62P49/48, output data increments by one LSB (14-bit) every clock cycle from code 0 to code 16383  
In ADS62P29/28, output data increments by one LSB (12-bit) every 4<sup>th</sup> clock cycle from code 0 to code 4095
- 101 Outputs custom pattern (use registers 0x51, 0x52 for setting the custom pattern), see [Figure 16](#) for an example of a custom pattern.
- 110 Unused
- 111 Unused

A7-A0 IN HEX	D7	D6	D5	D4	D3	D2	D1	D0
76	0	0	<OFFSET PEDESTAL – Common/CH B>					

D5-D0 <OFFSET PEDESTAL – Common/CH B>

When the offset correction is enabled, the final converged value (after the offset is corrected) will be the ideal ADC mid-code value (=8192 for P49/48, = 2048 for P29/28). A pedestal can be added to the final converged value by programming these bits. So, the final converged value will be = ideal mid-code + PEDESTAL. See "Offset Correction" in application section.

Applies to channel B (*only with independent control*).

- 011111 PEDESTAL = 31 LSB
- 011110 PEDESTAL = 30 LSB
- 011101 PEDESTAL = 29 LSB
- ....
- 000000 PEDESTAL = 0
- ....
- 111111 PEDESTAL = -1 LSB
- 111110 PEDESTAL = -2 LSB
- ....
- 100000 PEDESTAL = -32 LSB

DEVICE INFORMATION

PIN CONFIGURATION (LVDS MODE) – ADS62P49/P48

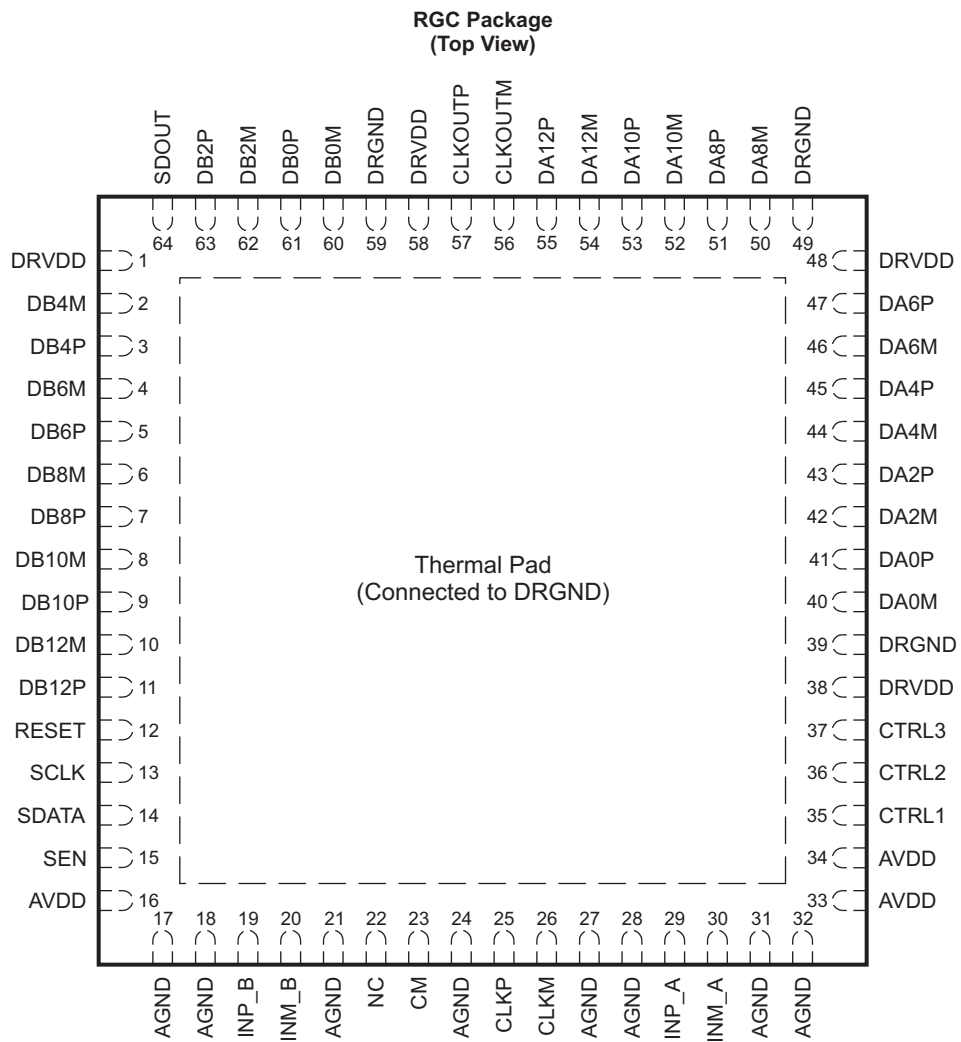

P0056-14

Figure 17.

**PIN CONFIGURATION (LVDS MODE) – ADS62P29/P28**

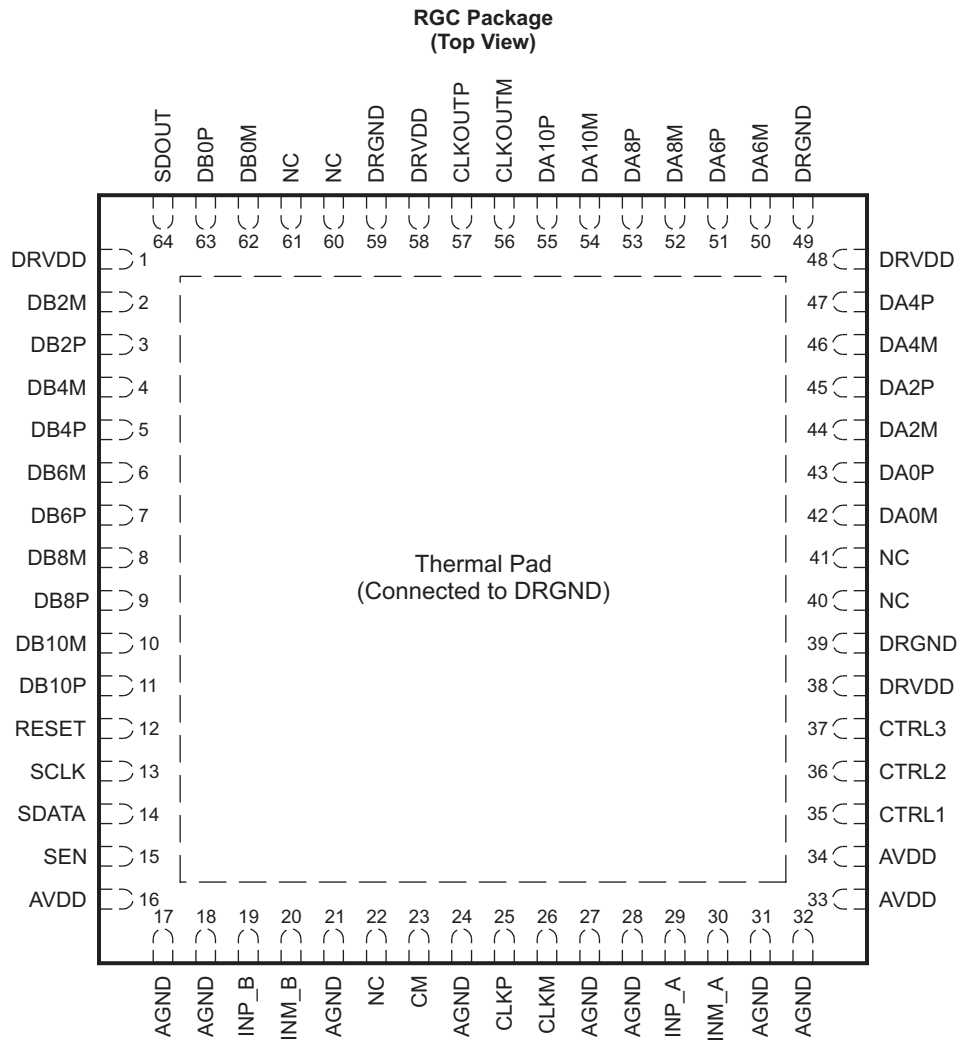

P0056-15

**Figure 18.**

**PIN ASSIGNMENTS (LVDS MODE) – ADS62P49/P48 and ADS62P29/P28**

PIN		NO. OF PINS	I/O	DESCRIPTION
NAME	NO.			
AVDD	16, 33, 34	3	I	Analog power supply
AGND	17, 18, 21, 24, 27, 28, 31, 32	8	I	Analog ground
CLKP, CLKM	25, 26	2	I	Differential clock input
INP_A, INM_A	29, 30	2	I	Differential analog input, Channel A
INP_B, INM_B	19, 20	2	I	Differential analog input, Channel B
VCM	23	1	IO	Internal reference mode – Common-mode voltage output. External reference mode – Reference input. The voltage forced on this pin sets the internal references.
RESET	12	1	I	Serial interface RESET input. When using the serial interface mode, the user <b>must</b> initialize internal registers through hardware RESET by applying a high-going pulse on this pin or by using software reset option. Refer to <b>Serial Interface</b> section.

**PIN ASSIGNMENTS (LVDS MODE) – ADS62P49/P48 and ADS62P29/P28 (continued)**

PIN		NO. OF PINS	I/O	DESCRIPTION	
NAME	NO.				
				In parallel interface mode, the user has to tie RESET pin permanently <b>high</b> . (SCLK and SEN are used as parallel control pins in this mode) The pin has an internal 100 kΩ pull-down resistor.	
SCLK	13	1	I	This pin functions as serial interface clock input when RESET is <b>low</b> . It controls selection of internal or external reference when RESET is tied <b>high</b> . See <a href="#">Table 5</a> for detailed information. The pin has an internal 100 kΩ pull-down resistor.	
SDATA	14	1	I	Serial interface data input. The pin has an internal 100kΩ pull-down resistor. It has no function in parallel interface mode and can be tied to ground.	
SEN	15	1	I	This pin functions as serial interface enable input when RESET is <b>low</b> . It controls selection of data format and interface type when RESET is tied high. See <a href="#">Table 6</a> for detailed information. The pin has an internal 100 kΩ pull-up resistor to AVDD	
SDOUT	64	1	O	This pin functions as serial interface register readout, when the <SERIAL READOUT> bit is enabled. When <SERIAL READOUT> = 0, this pin forces logic LOW and is not 3-stated.	
CTRL1	35	1	I	Digital control input pins. Together, they control various power down modes. The pin has an internal 100kΩ pull-down resistor.	
CTRL2	36	1	I		
CTRL3	37	1	I		
CLKOUTP	57	1	O	Differential output clock, true	
CLKOUTM	56	1	O	Differential output clock, complement	
DA0P, DA0M	Refer to <a href="#">Figure 17</a> and <a href="#">Figure 18</a>	2	O	Differential output data pair, D0 and D1 multiplexed – Channel A	
DA2P, DA2M		2	O	Differential output data D2 and D3 multiplexed – Channel A	
DA4P, DA4M		2	O	Differential output data D4 and D5 multiplexed – Channel A	
DA6P, DA6M		2	O	Differential output data D6 and D7 multiplexed – Channel A	
DA8P, DA8M		2	O	Differential output data D8 and D9 multiplexed – Channel A	
DA10P, DA10M		2	O	Differential output data D10 and D11 multiplexed – Channel A	
DA12P, DA12M		2	O	Differential output data D12 and D13 multiplexed – Channel A	
DB0P, DB0M		2	O	Differential output data pair, D0 and D1 multiplexed – Channel B	
DB2P, DB2M		2	O	Differential output data D2 and D3 multiplexed – Channel B	
DB4P, DB4M		2	O	Differential output data D4 and D5 multiplexed – Channel B	
DB6P, DB6M		2	O	Differential output data D6 and D7 multiplexed – Channel B	
DB8P, DB8M		2	O	Differential output data D8 and D9 multiplexed – Channel B	
DB10P, DB10M		2	O	Differential output data D10 and D11 multiplexed – Channel B	
DB12P, DB12M		2	O	Differential output data D12 and D13 multiplexed – Channel B	
DRVDD		1, 38, 48, 58	4	I	Output buffer supply
DRGND		39, 49, 59, PAD	4	I	Output buffer ground
NC	Refer to <a href="#">Figure 17</a> and <a href="#">Figure 18</a>			Do not connect	

**PIN CONFIGURATION (CMOS MODE) – ADS62P49/P48**

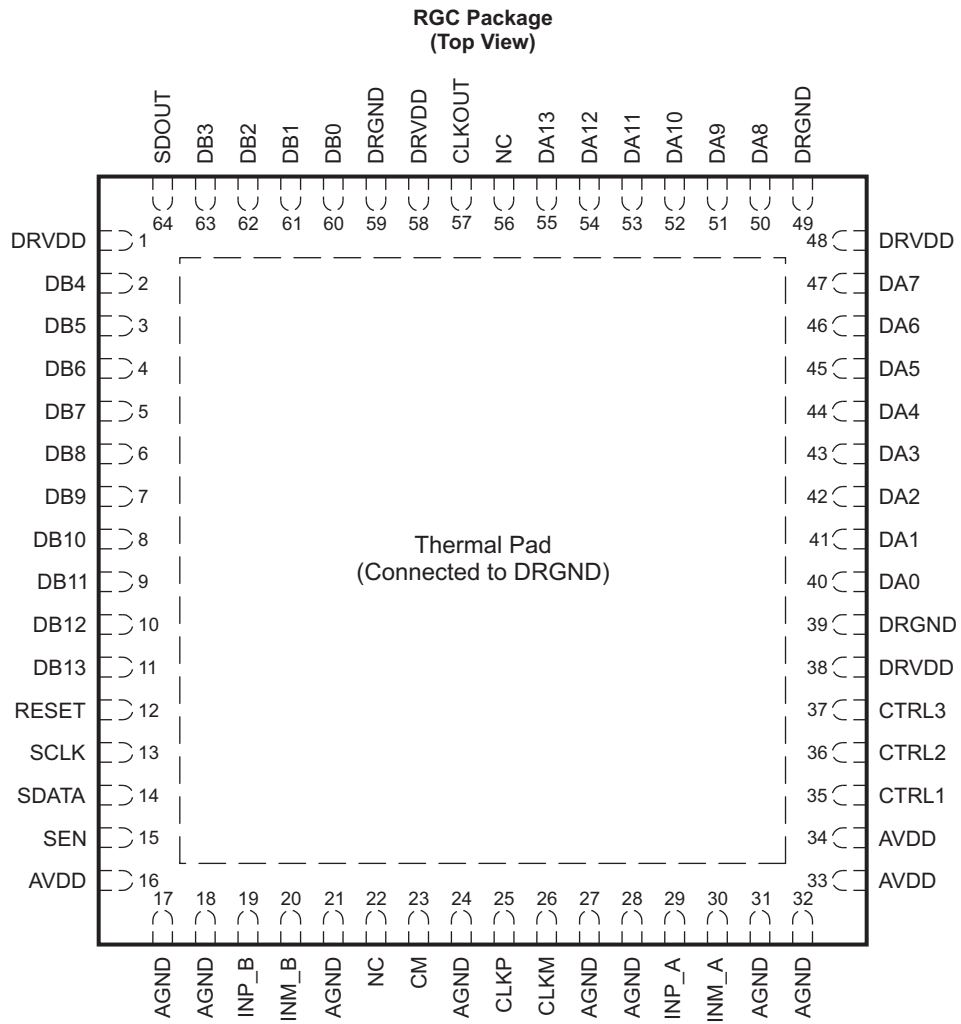

P0056-16

**Figure 19.**

**PIN CONFIGURATION (CMOS MODE) – ADS62P29/P28**

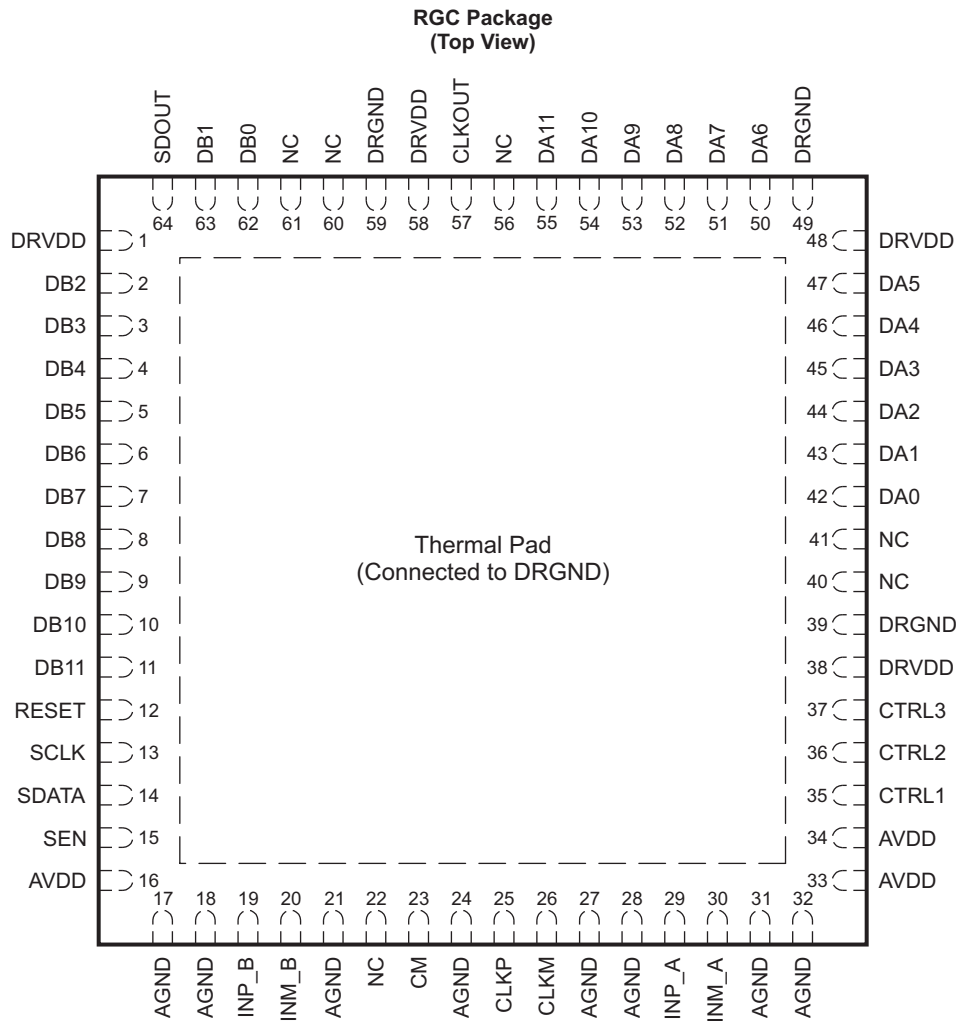

P0056-17

**Figure 20.**

**PIN ASSIGNMENTS (CMOS MODE) – ADS62P49/P48 and ADS62P29/P28**

PIN		NO. OF PINS	I/O	DESCRIPTION
NAME	NO.			
AVDD	16, 33, 34	3	I	Analog power supply
AGND	17, 18, 21, 24, 27, 28, 31, 32	8	I	Analog ground
CLKP, CLKM	25, 26	2	I	Differential clock input
INP_A, INM_A	29, 30	2	I	Differential analog input, Channel A
INP_B, INM_B	19, 20	2	I	Differential analog input, Channel B
VCM	23	1	IO	Internal reference mode – Common-mode voltage output. External reference mode – Reference input. The voltage forced on this pin sets the internal references.
RESET	12	1	I	Serial interface RESET input. When using the serial interface mode, the user <b>MUST</b> initialize internal registers through hardware RESET by applying a high-going pulse on this pin or by using software reset option. Refer to <b>SERIAL INTERFACE</b> section.

**PIN ASSIGNMENTS (CMOS MODE) – ADS62P49/P48 and ADS62P29/P28 (continued)**

PIN		NO. OF PINS	I/O	DESCRIPTION
NAME	NO.			
				In parallel interface mode, the user has to tie RESET pin permanently <b>high</b> . (SCLK and SEN are used as parallel control pins in this mode. ) The pin has an internal 100 kΩ pull-down resistor.
SCLK	13	1	I	This pin functions as serial interface clock input when RESET is <b>low</b> . It controls selection of internal or external reference when RESET is tied <b>high</b> . See <a href="#">Table 5</a> for detailed information. The pin has an internal 100-kΩ pull-down resistor.
SDATA	14	1	I	Serial interface data input. The pin has an internal 100-kΩ pull-down resistor. It has no function in parallel interface mode and can be tied to ground.
SEN	15	1	I	This pin functions as serial interface enable input when RESET is <b>low</b> . It controls selection of data format and interface type when RESET is tied <b>high</b> . See <a href="#">Table 6</a> for detailed information. The pin has an internal 100 kΩ pull-up resistor to AVDD.
SDOUT	64	1	O	This pin functions as serial interface register readout, when the <SERIAL READOUT> bit is enabled. When <SERIAL READOUT> = 0, this pin forces logic LOW and is not 3-stated.
CTRL1	35	1	I	Digital control input pins. Together, they control various power down modes. The pin has an internal 100 kΩ pull-down resistor.
CTRL2	36	1	I	
CTRL3	37	1	I	
CLKOUT	57	1	O	CMOS output clock
DA0-DA13	Refer to <a href="#">Figure 19</a> and <a href="#">Figure 20</a>	14	O	Channel A ADC output data bits, CMOS levels
DB0-DB13		14	O	Channel B ADC output data bits, CMOS levels
DRVDD	1, 38, 48, 58	4	I	Output buffer supply
DRGND	39, 49, 59, PAD	4	I	Output buffer ground
NC	Refer to <a href="#">Figure 19</a> and <a href="#">Figure 20</a>			Do not connect

**TYPICAL CHARACTERISTICS – ADS62P49**

All plots are at 25°C, AVDD = 3.3 V, DRVDD = 1.8 V, maximum rated sampling frequency, sine wave input clock. 1.5 V<sub>PP</sub> differential clock amplitude, 50% clock duty cycle, -1 dBFS differential analog input, internal reference mode, 0 dB gain, LVDS output interface, 32K point FFT (unless otherwise noted)

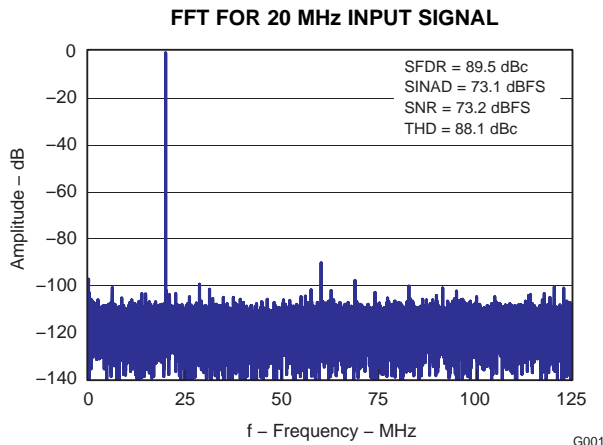

Figure 21.

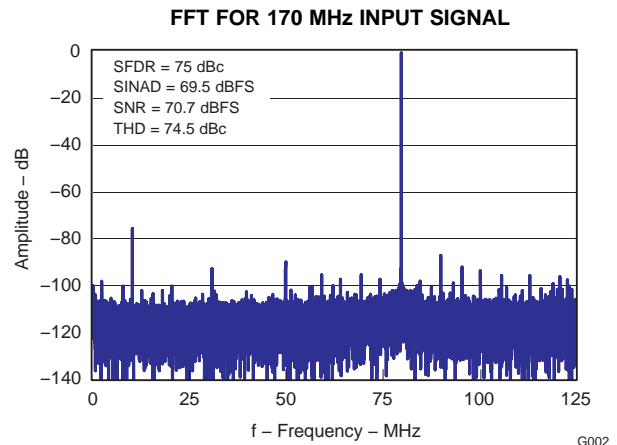

Figure 22.

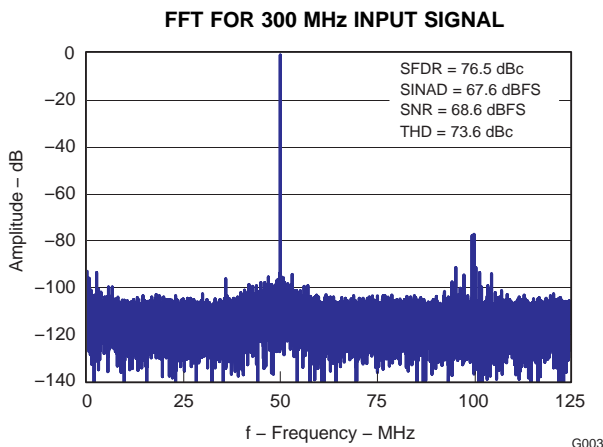

Figure 23.

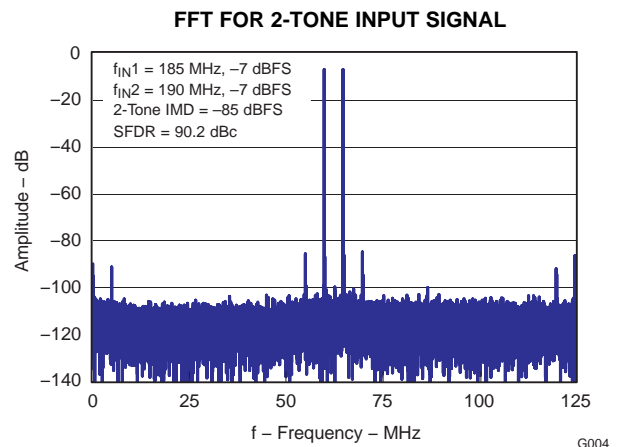

Figure 24.

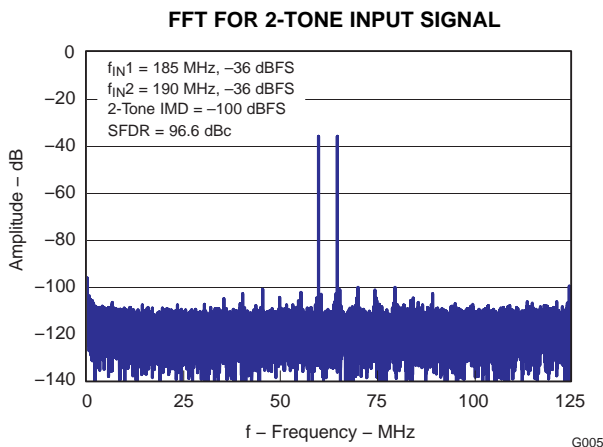

Figure 25.

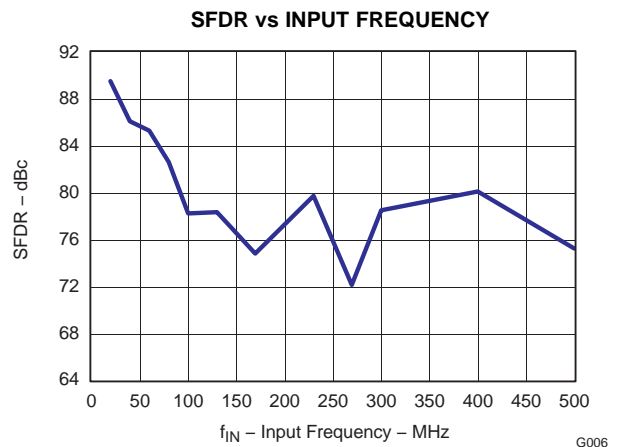

Figure 26.

**TYPICAL CHARACTERISTICS – ADS62P49 (continued)**

All plots are at 25°C, AVDD = 3.3 V, DRVDD = 1.8 V, maximum rated sampling frequency, sine wave input clock. 1.5 V<sub>PP</sub> differential clock amplitude, 50% clock duty cycle, -1 dBFS differential analog input, internal reference mode, 0 dB gain, LVDS output interface, 32K point FFT (unless otherwise noted)

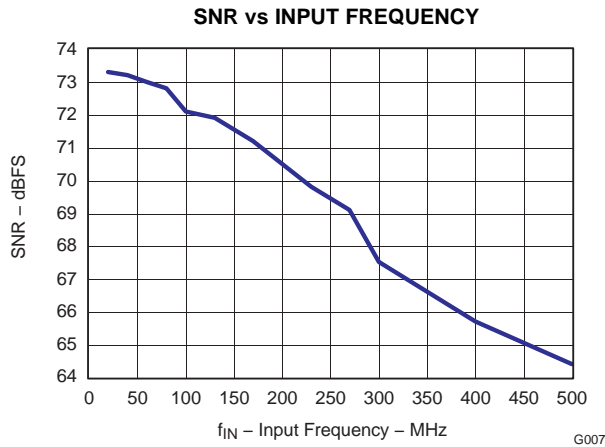

Figure 27.

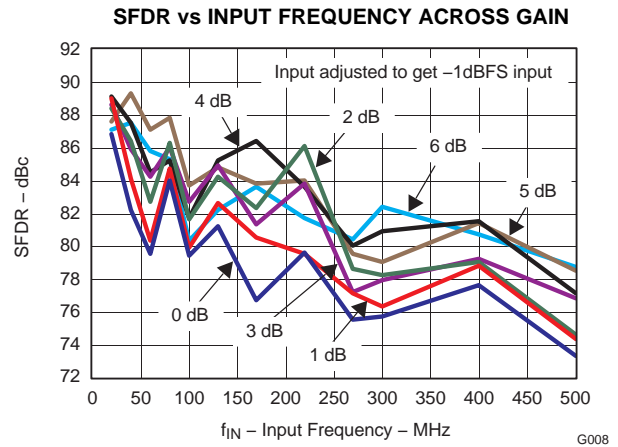

Figure 28.

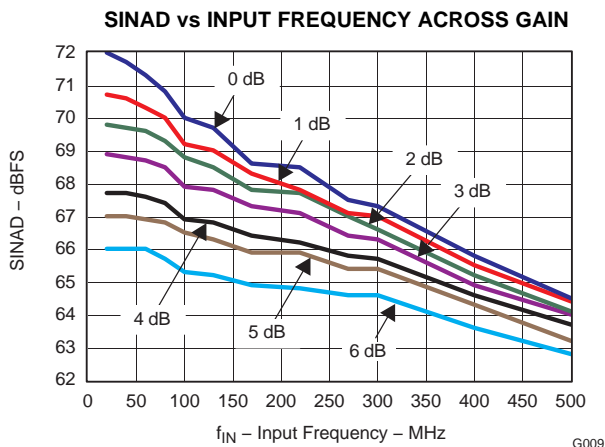

Figure 29.

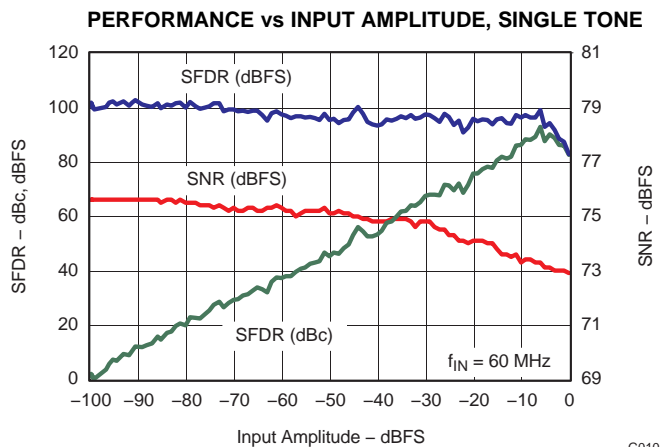

Figure 30.

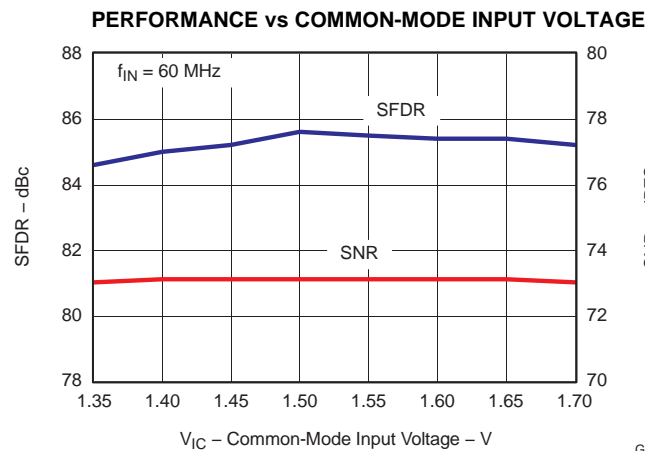

Figure 31.

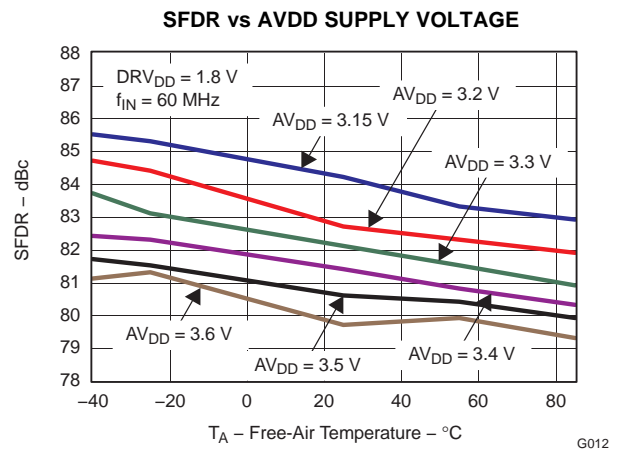

Figure 32.

**TYPICAL CHARACTERISTICS – ADS62P49 (continued)**

All plots are at 25°C, AVDD = 3.3 V, DRVDD = 1.8 V, maximum rated sampling frequency, sine wave input clock. 1.5 V<sub>PP</sub> differential clock amplitude, 50% clock duty cycle, -1 dBFS differential analog input, internal reference mode, 0 dB gain, LVDS output interface, 32K point FFT (unless otherwise noted)

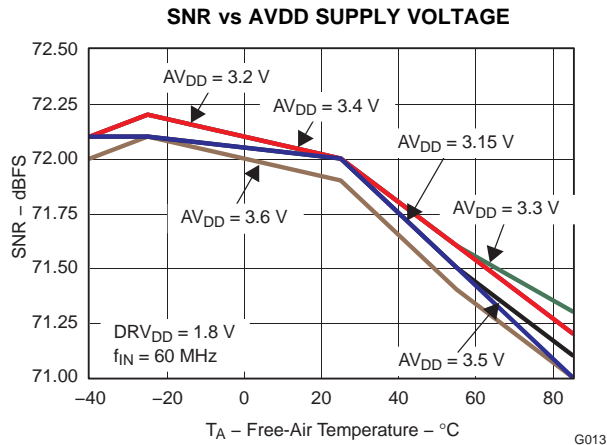

Figure 33.

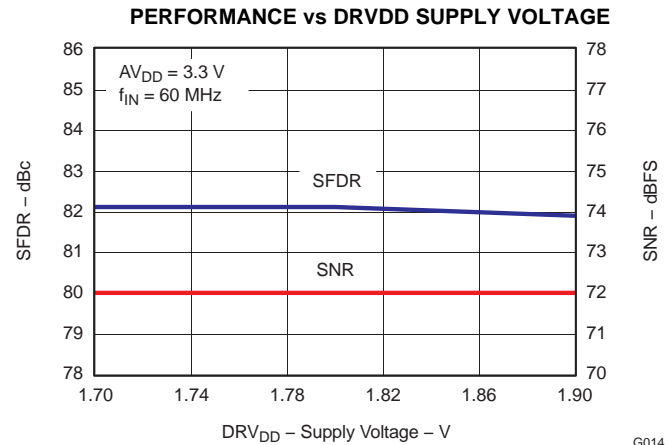

Figure 34.

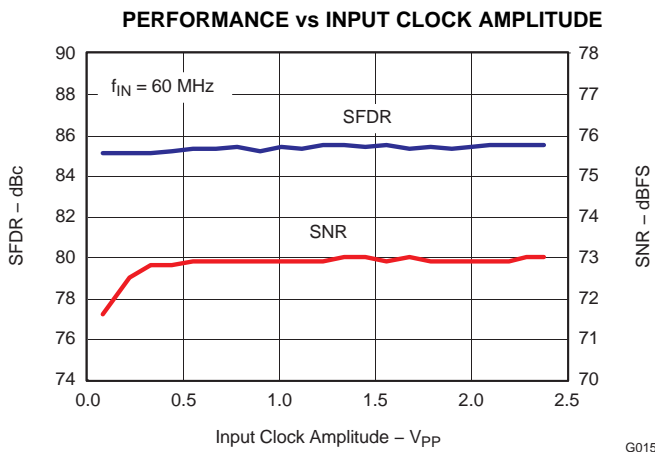

Figure 35.

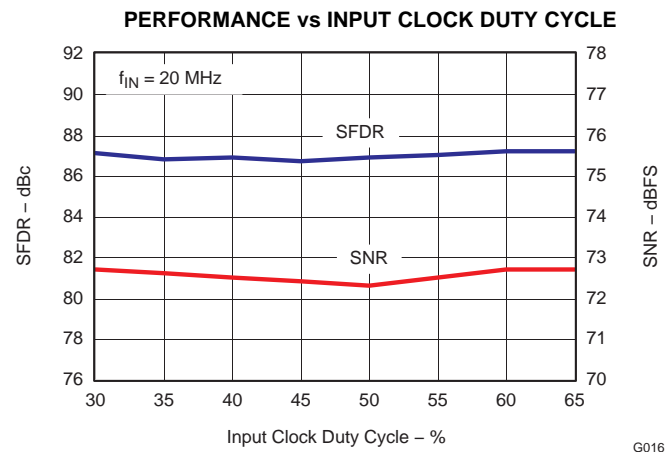

Figure 36.

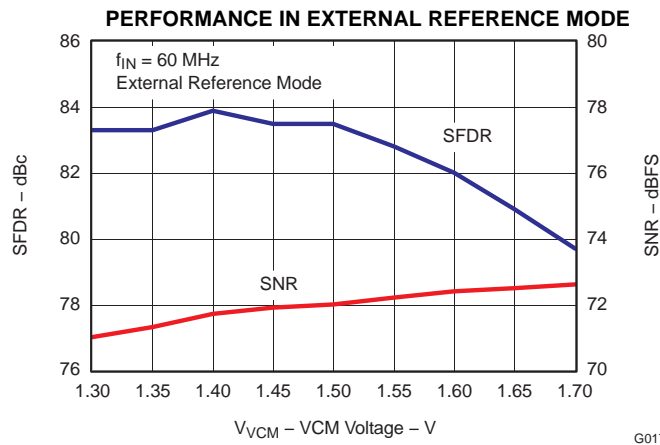

Figure 37.

**TYPICAL CHARACTERISTICS – ADS62P48**

All plots are at 25°C, AVDD = 3.3 V, DRVDD = 1.8 V, maximum rated sampling frequency, sine wave input clock. 1.5 V<sub>PP</sub> differential clock amplitude, 50% clock duty cycle, -1 dBFS differential analog input, internal reference mode, 0 dB gain, LVDS output interface, 32K point FFT (unless otherwise noted)

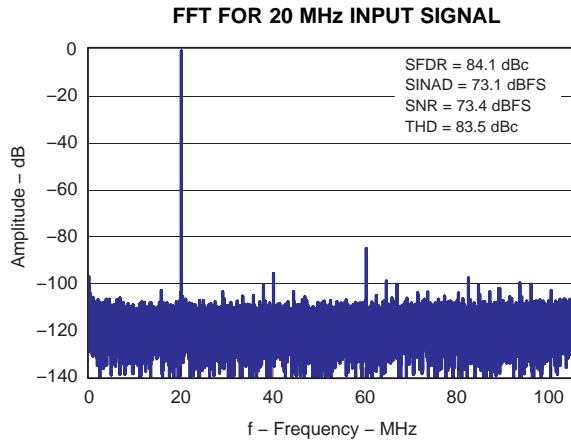

Figure 38.

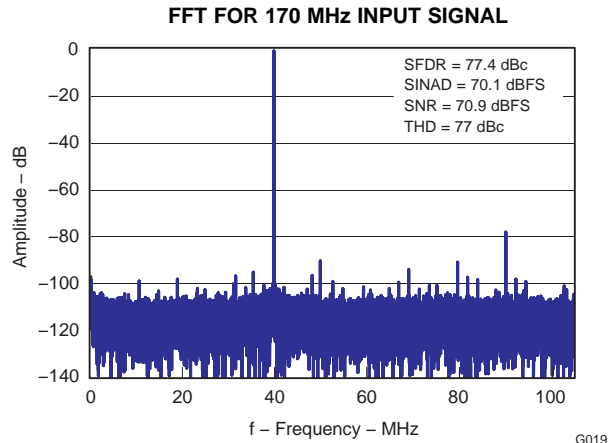

Figure 39.

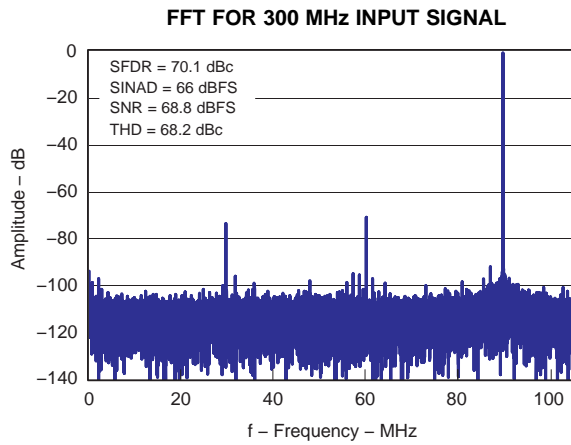

Figure 40.

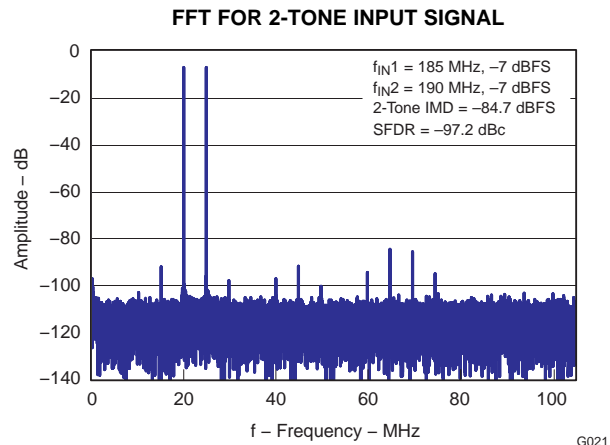

Figure 41.

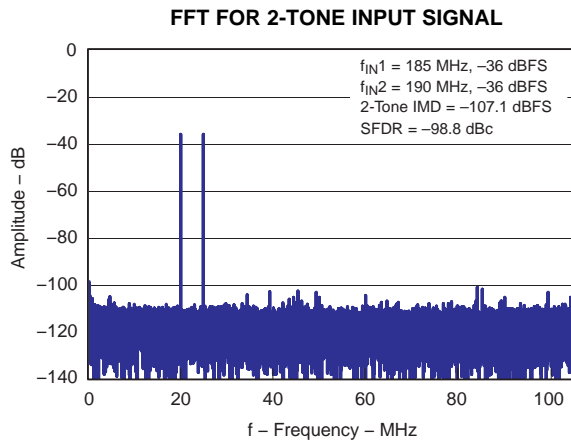

Figure 42.

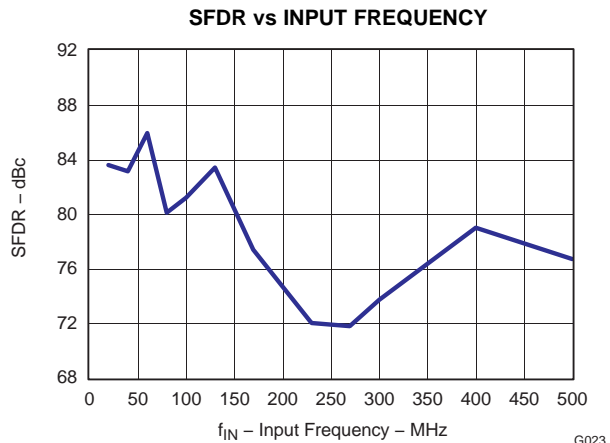

Figure 43.

**TYPICAL CHARACTERISTICS – ADS62P48 (continued)**

All plots are at 25°C, AVDD = 3.3 V, DRVDD = 1.8 V, maximum rated sampling frequency, sine wave input clock. 1.5 V<sub>PP</sub> differential clock amplitude, 50% clock duty cycle, -1 dBFS differential analog input, internal reference mode, 0 dB gain, LVDS output interface, 32K point FFT (unless otherwise noted)

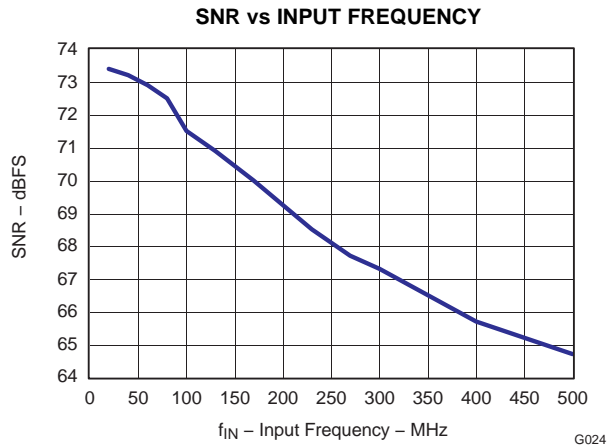

Figure 44.

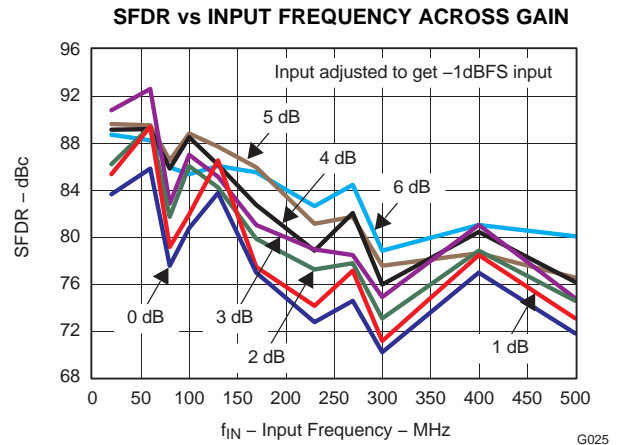

Figure 45.

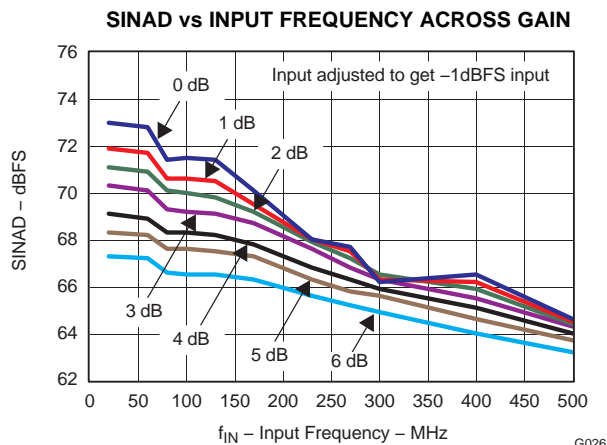

Figure 46.

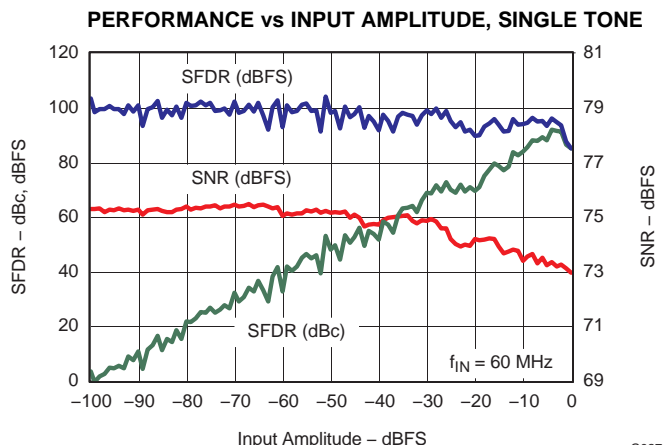

Figure 47.

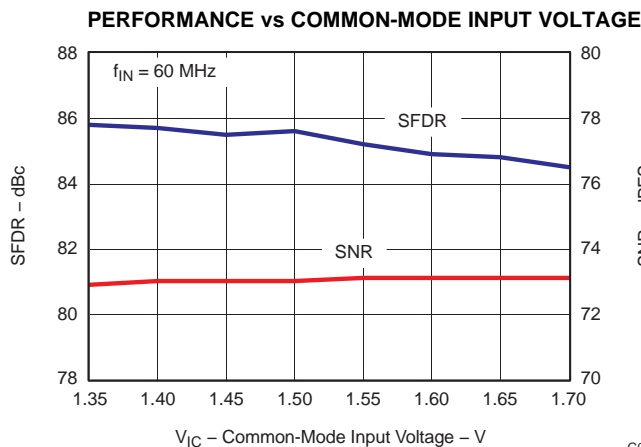

Figure 48.

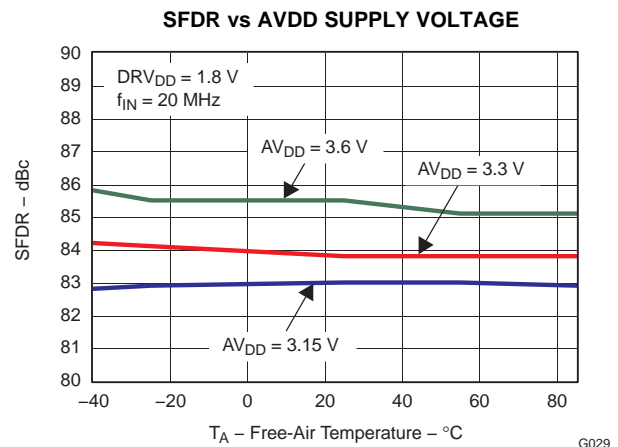

Figure 49.

**TYPICAL CHARACTERISTICS – ADS62P48 (continued)**

All plots are at 25°C, AVDD = 3.3 V, DRVDD = 1.8 V, maximum rated sampling frequency, sine wave input clock. 1.5 V<sub>PP</sub> differential clock amplitude, 50% clock duty cycle, -1 dBFS differential analog input, internal reference mode, 0 dB gain, LVDS output interface, 32K point FFT (unless otherwise noted)

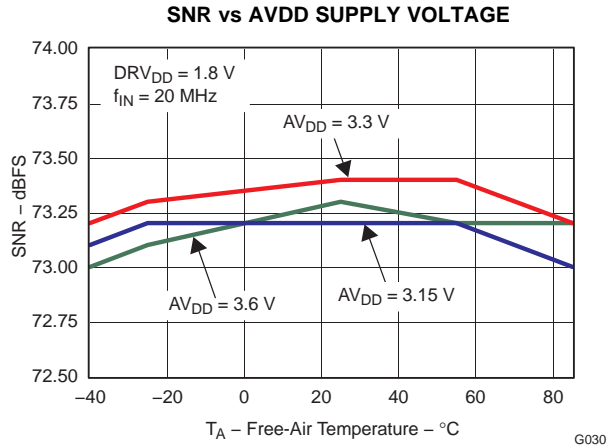

Figure 50.

G030

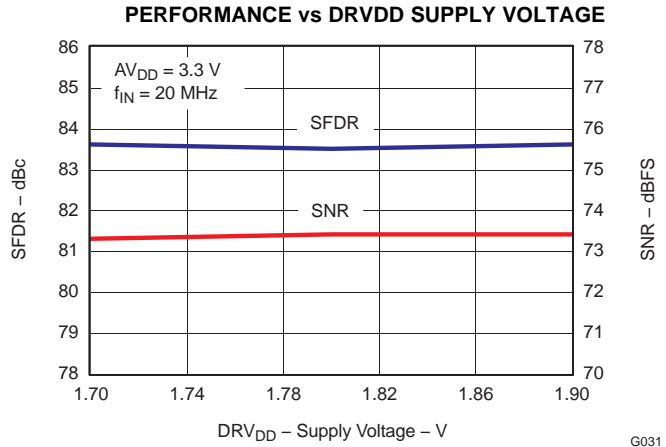

Figure 51.

G031

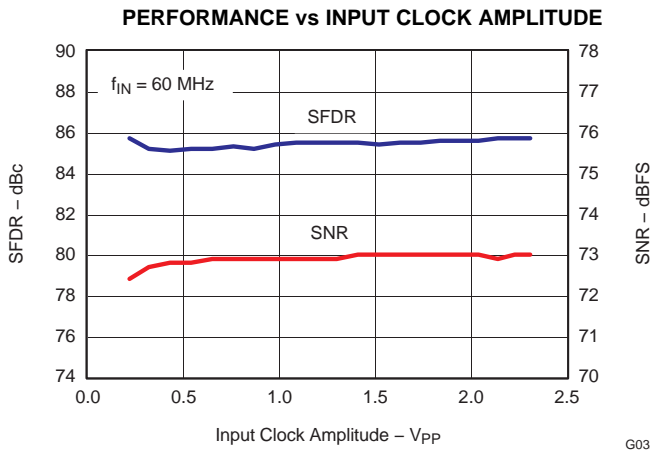

Figure 52.

G032

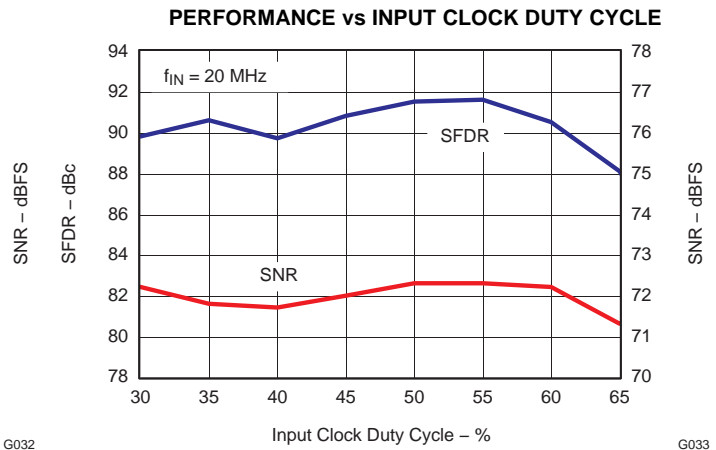

Figure 53.

G033

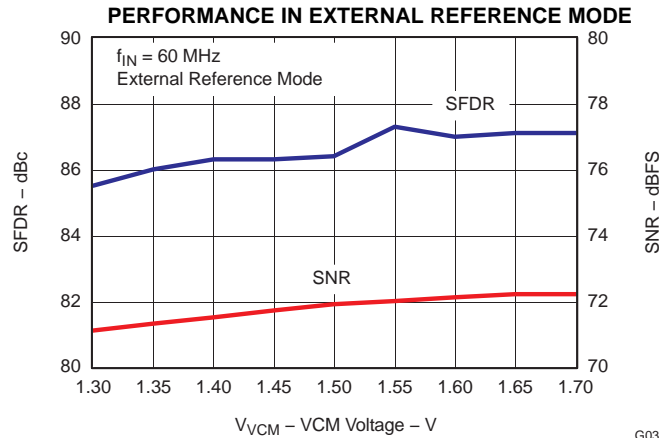

Figure 54.

G034

### TYPICAL CHARACTERISTICS – ADS62P29

All plots are at 25°C, AVDD = 3.3 V, DRVDD = 1.8 V, maximum rated sampling frequency, sine wave input clock. 1.5 V<sub>PP</sub> differential clock amplitude, 50% clock duty cycle, -1 dBFS differential analog input, internal reference mode, 0 dB gain, LVDS output interface, 32K point FFT (unless otherwise noted)

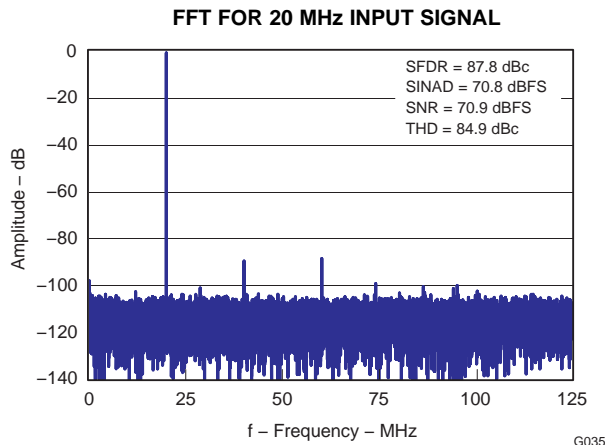

Figure 55.

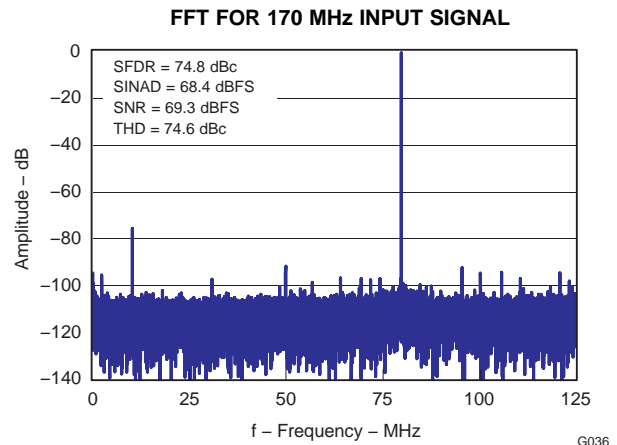

Figure 56.

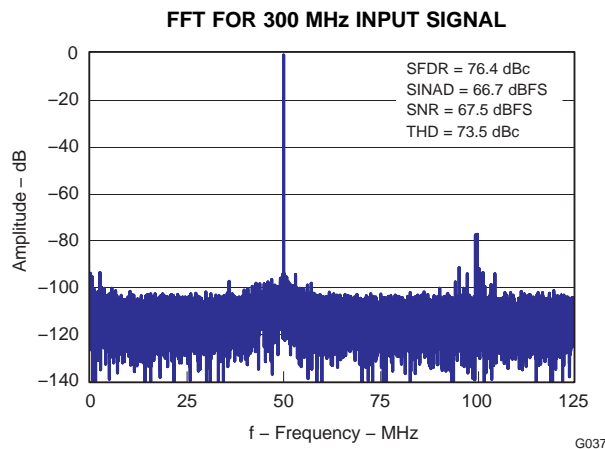

Figure 57.

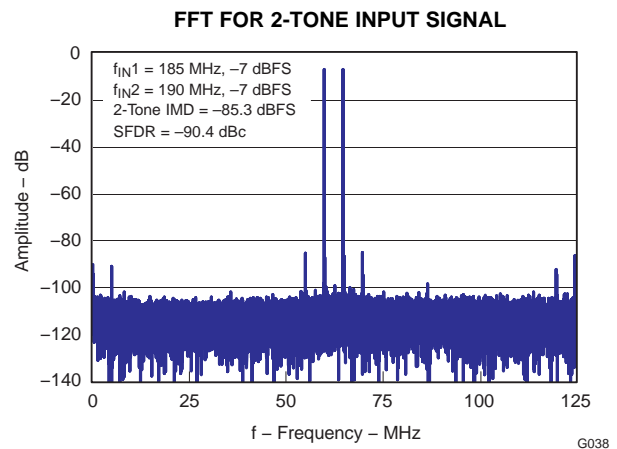

Figure 58.

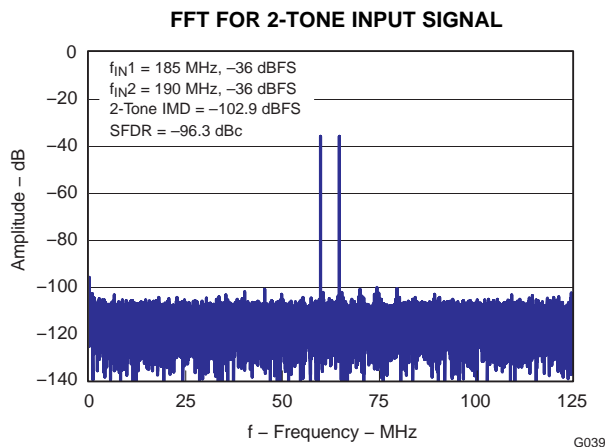

Figure 59.

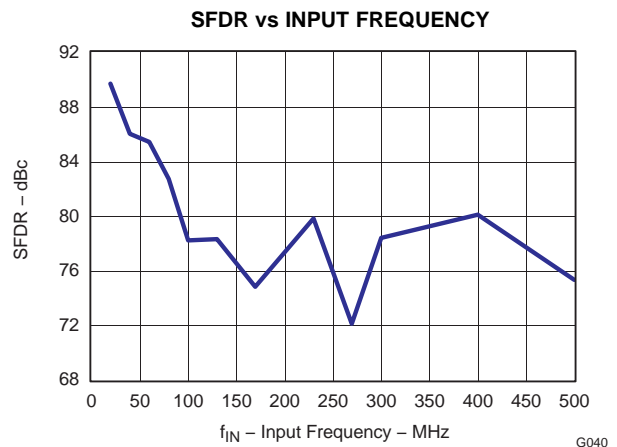

Figure 60.

**TYPICAL CHARACTERISTICS – ADS62P29 (continued)**

All plots are at 25°C, AVDD = 3.3 V, DRVDD = 1.8 V, maximum rated sampling frequency, sine wave input clock. 1.5 V<sub>PP</sub> differential clock amplitude, 50% clock duty cycle, -1 dBFS differential analog input, internal reference mode, 0 dB gain, LVDS output interface, 32K point FFT (unless otherwise noted)

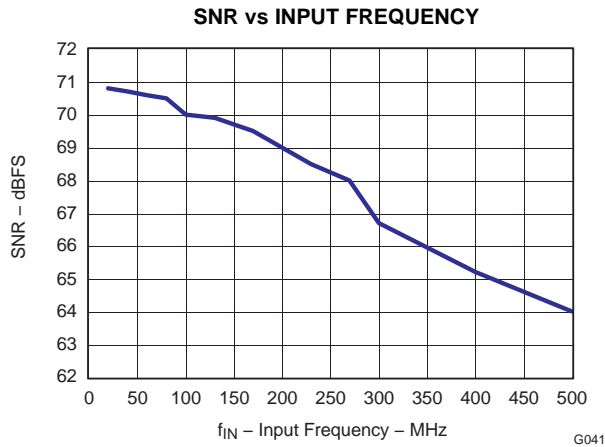

Figure 61.

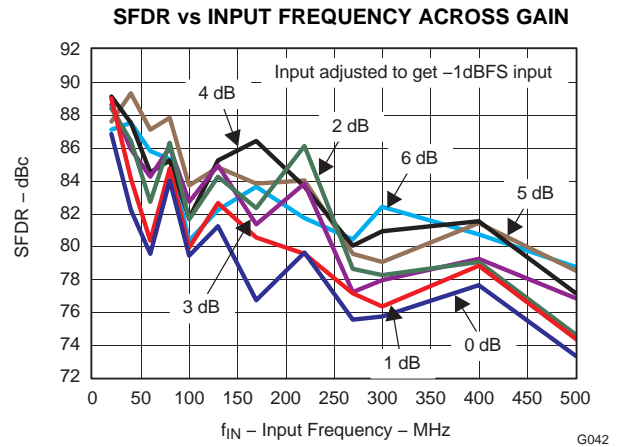

Figure 62.

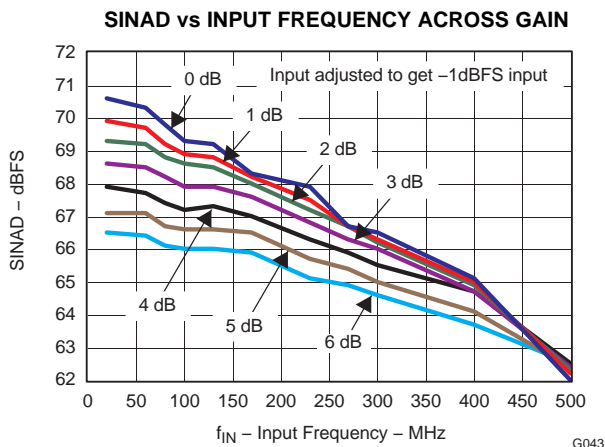

Figure 63.

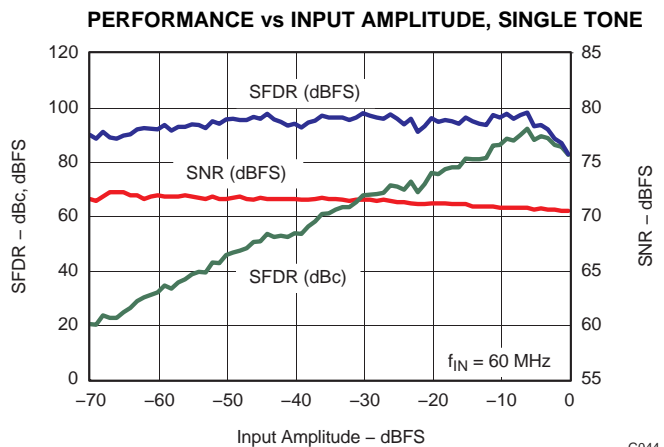

Figure 64.

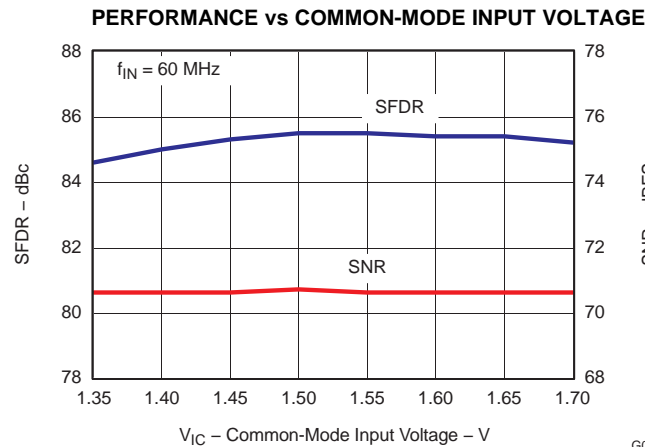

Figure 65.

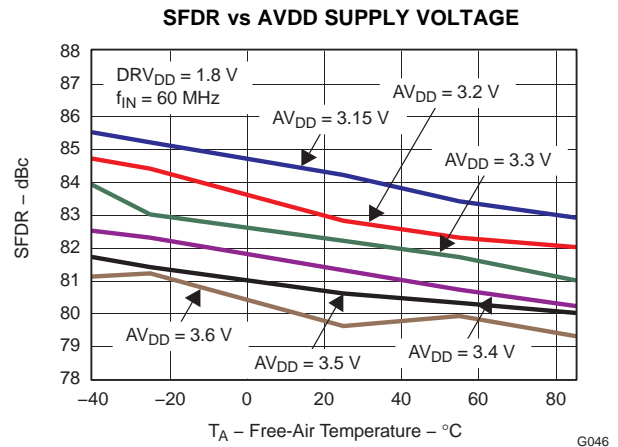

Figure 66.

**TYPICAL CHARACTERISTICS – ADS62P29 (continued)**

All plots are at 25°C, AVDD = 3.3 V, DRVDD = 1.8 V, maximum rated sampling frequency, sine wave input clock. 1.5 V<sub>PP</sub> differential clock amplitude, 50% clock duty cycle, -1 dBFS differential analog input, internal reference mode, 0 dB gain, LVDS output interface, 32K point FFT (unless otherwise noted)

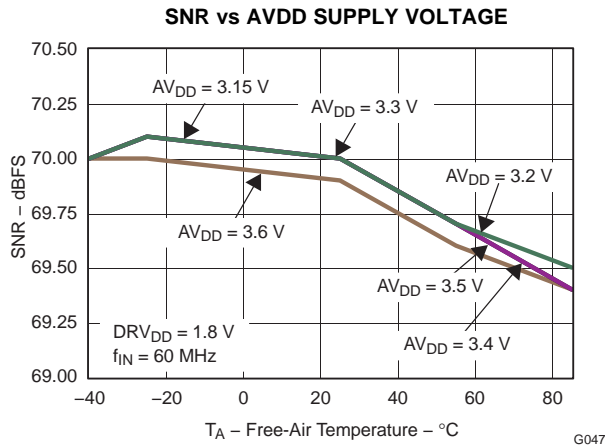

Figure 67.

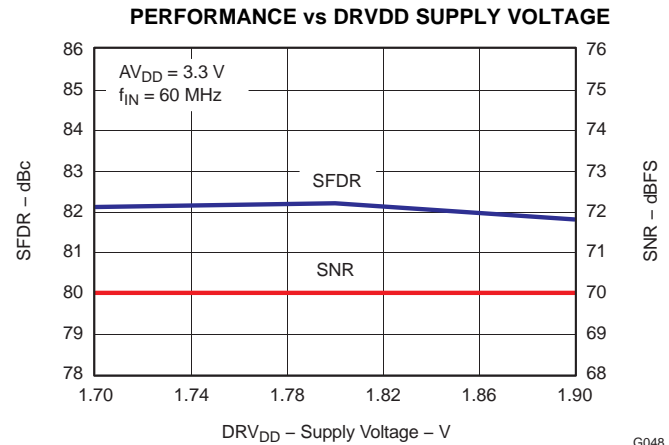

Figure 68.

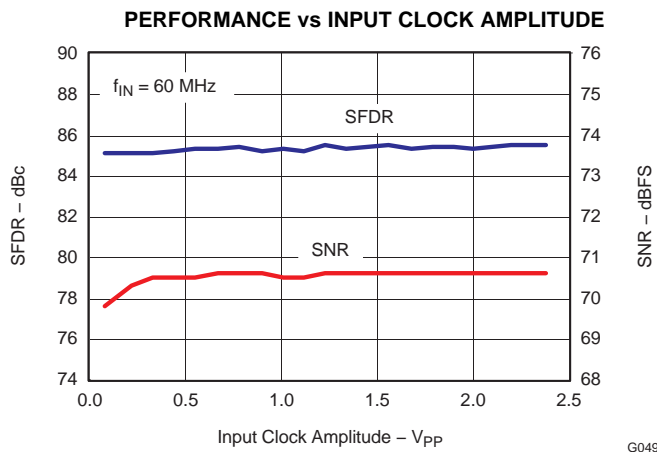

Figure 69.

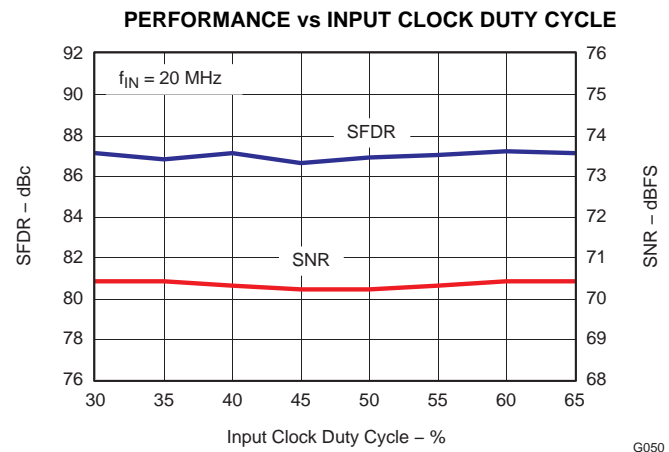

Figure 70.

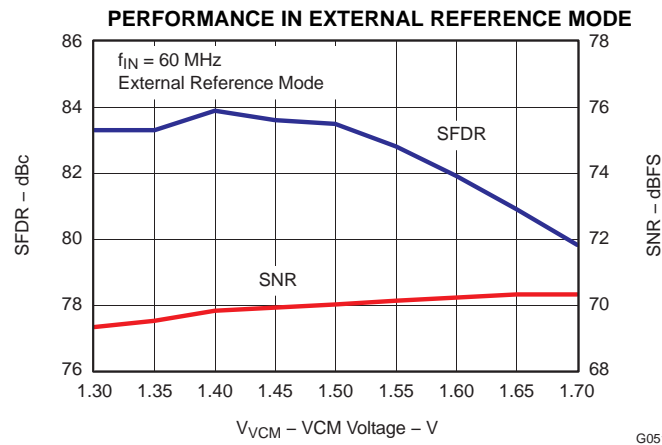

Figure 71.

### TYPICAL CHARACTERISTICS – ADS62P28

All plots are at 25°C, AVDD = 3.3 V, DRVDD = 1.8 V, maximum rated sampling frequency, sine wave input clock. 1.5 V<sub>PP</sub> differential clock amplitude, 50% clock duty cycle, -1 dBFS differential analog input, internal reference mode, 0 dB gain, LVDS output interface, 32K point FFT (unless otherwise noted)

FFT FOR 20 MHz INPUT SIGNAL

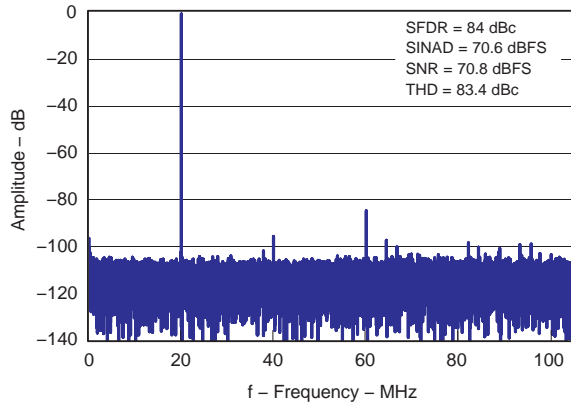

Figure 72.

G052

FFT FOR 170 MHz INPUT SIGNAL

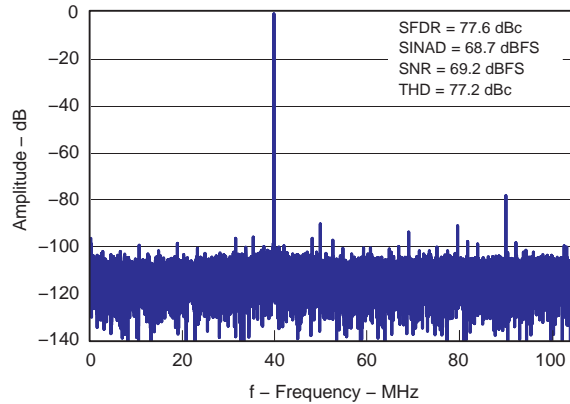

Figure 73.

G053

FFT FOR 300 MHz INPUT SIGNAL

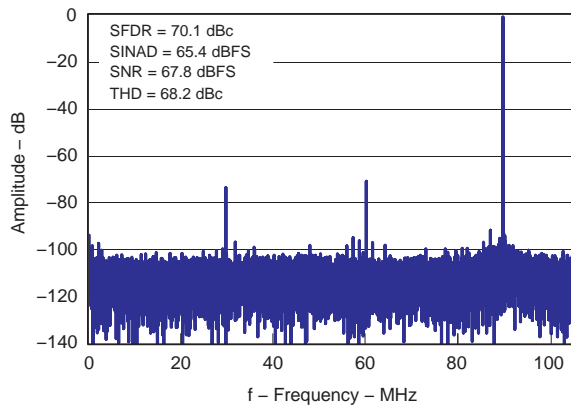

Figure 74.

G054

FFT FOR 2-TONE INPUT SIGNAL

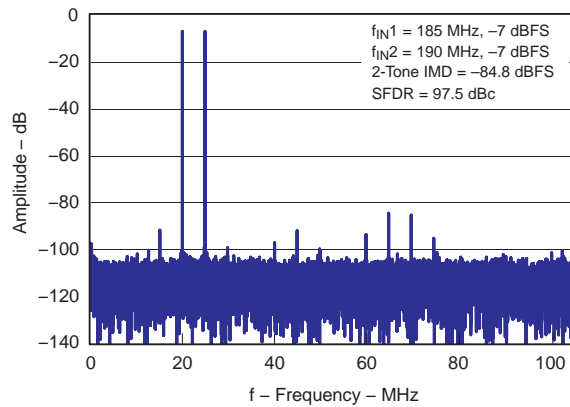

Figure 75.

G055

FFT FOR 2-TONE INPUT SIGNAL

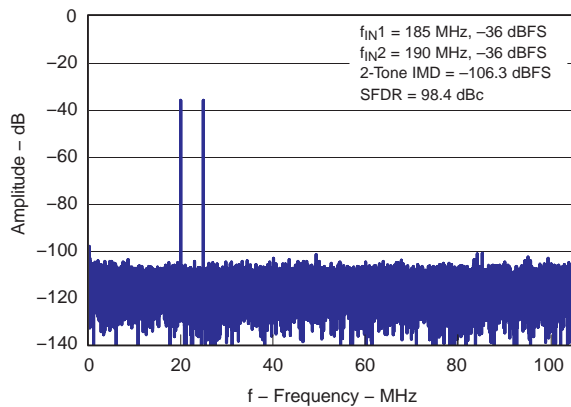

Figure 76.

G056

SFDR vs INPUT FREQUENCY

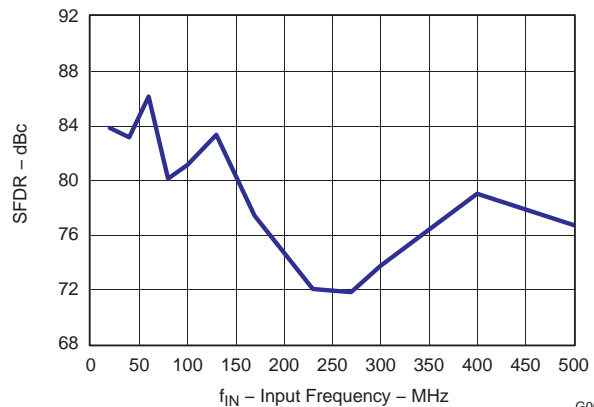

Figure 77.

G057

**TYPICAL CHARACTERISTICS – ADS62P28 (continued)**

All plots are at 25°C, AVDD = 3.3 V, DRVDD = 1.8 V, maximum rated sampling frequency, sine wave input clock. 1.5 V<sub>PP</sub> differential clock amplitude, 50% clock duty cycle, -1 dBFS differential analog input, internal reference mode, 0 dB gain, LVDS output interface, 32K point FFT (unless otherwise noted)

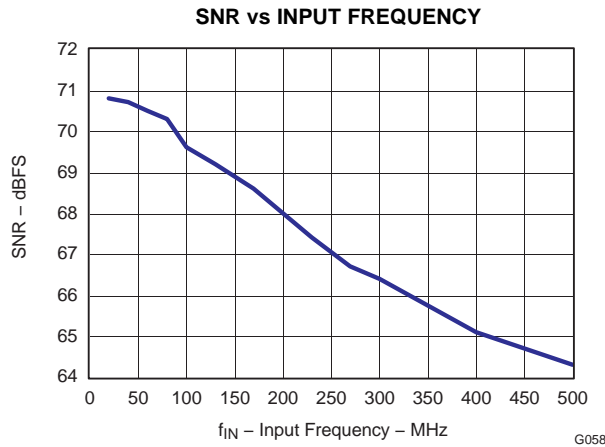

Figure 78.

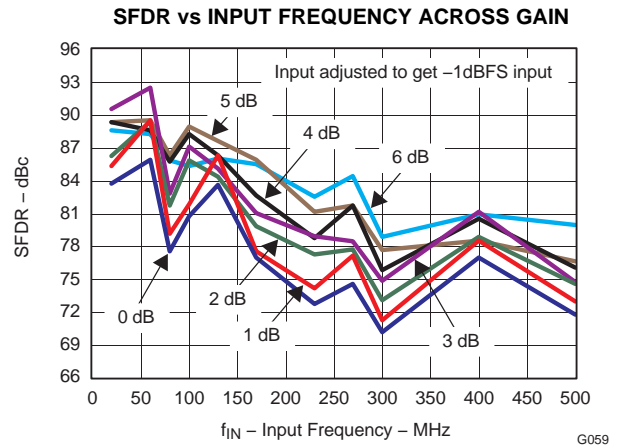

Figure 79.

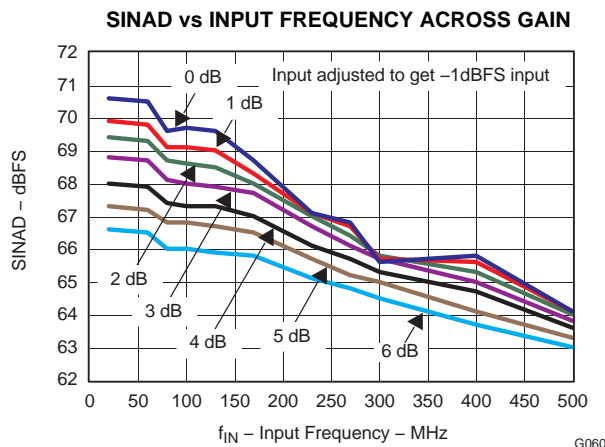

Figure 80.

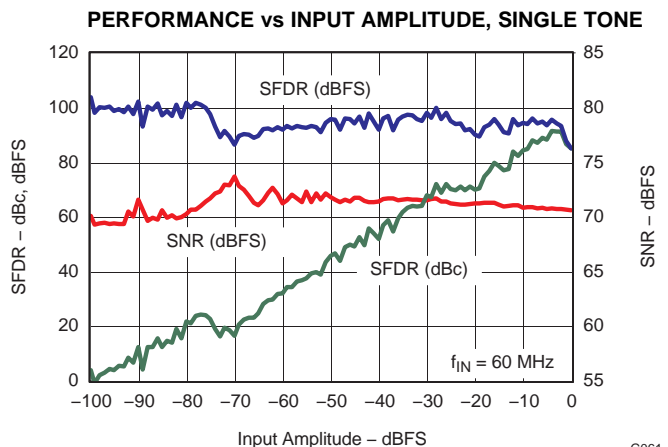

Figure 81.

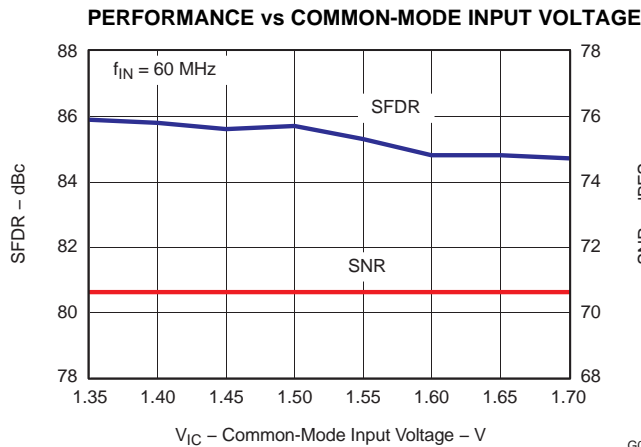

Figure 82.

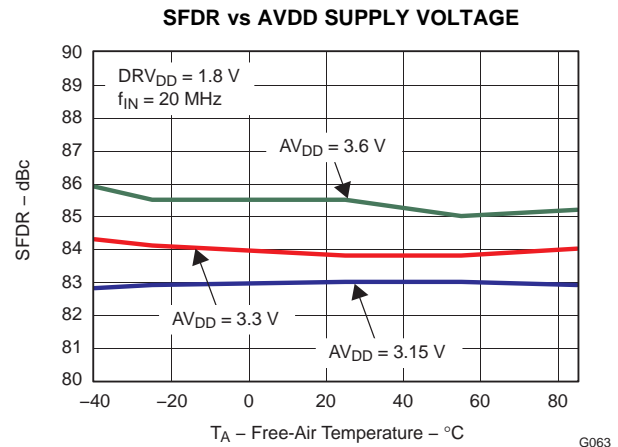

Figure 83.

**TYPICAL CHARACTERISTICS – ADS62P28 (continued)**

All plots are at 25°C, AVDD = 3.3 V, DRVDD = 1.8 V, maximum rated sampling frequency, sine wave input clock. 1.5 V<sub>PP</sub> differential clock amplitude, 50% clock duty cycle, -1 dBFS differential analog input, internal reference mode, 0 dB gain, LVDS output interface, 32K point FFT (unless otherwise noted)

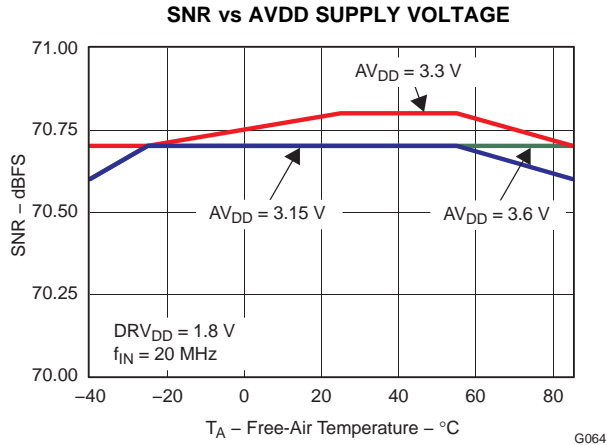

Figure 84.

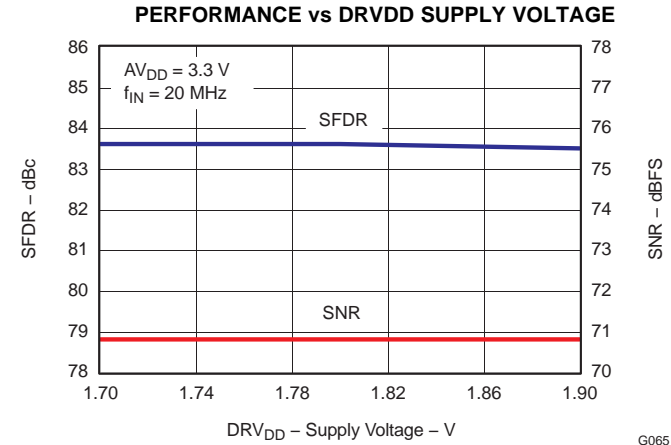

Figure 85.

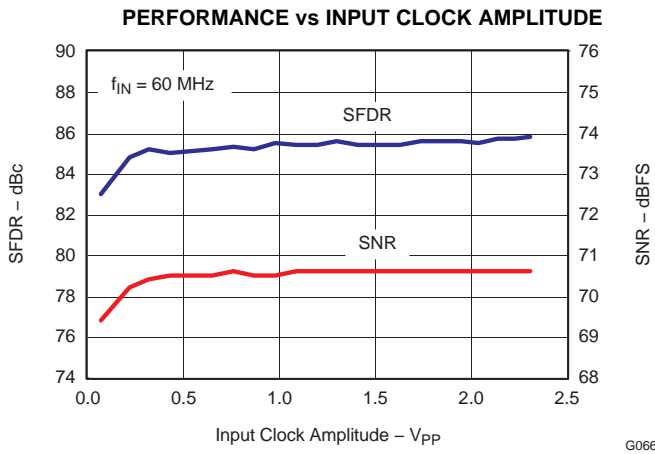

Figure 86.

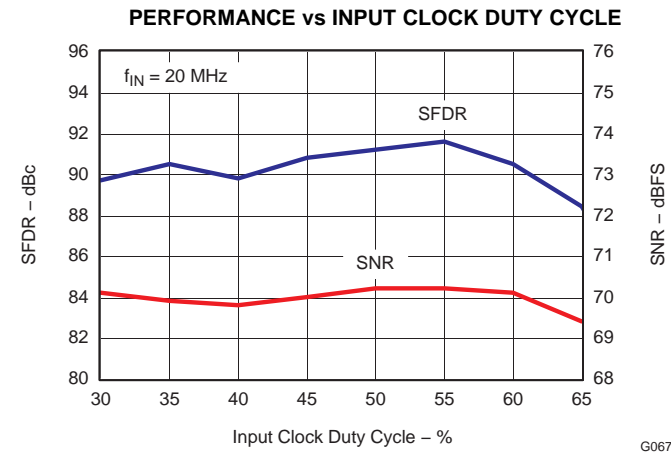

Figure 87.

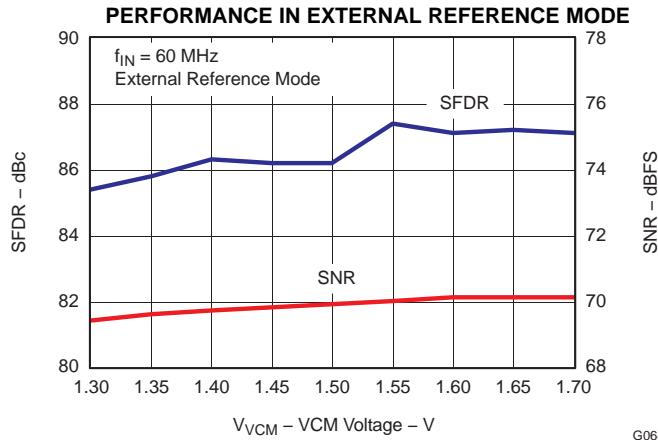

Figure 88.

### TYPICAL CHARACTERISTICS – COMMON PLOTS

All plots are at 25°C, AVDD = 3.3 V, DRVDD = 1.8 V, maximum rated sampling frequency, sine wave input clock. 1.5 V<sub>PP</sub> differential clock amplitude, 50% clock duty cycle, -1 dBFS differential analog input, internal reference mode, 0 dB gain, LVDS output interface, 32K point FFT (unless otherwise noted)

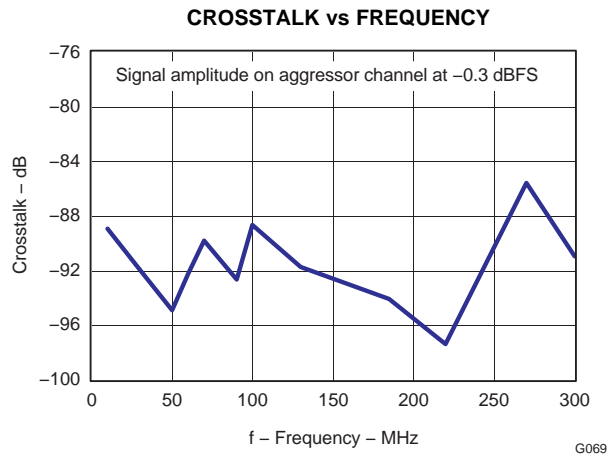

Figure 89.

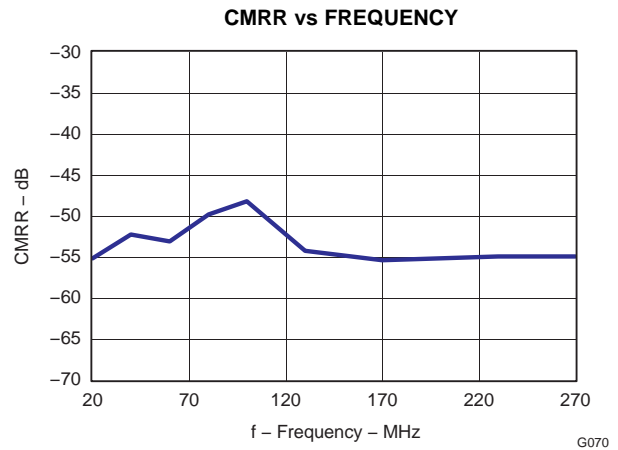

Figure 90.

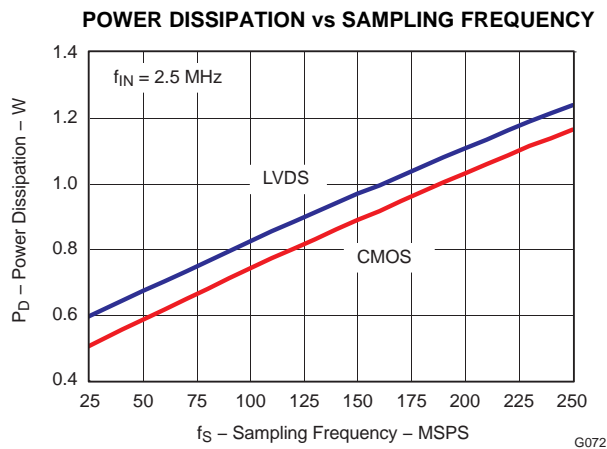

Figure 91.

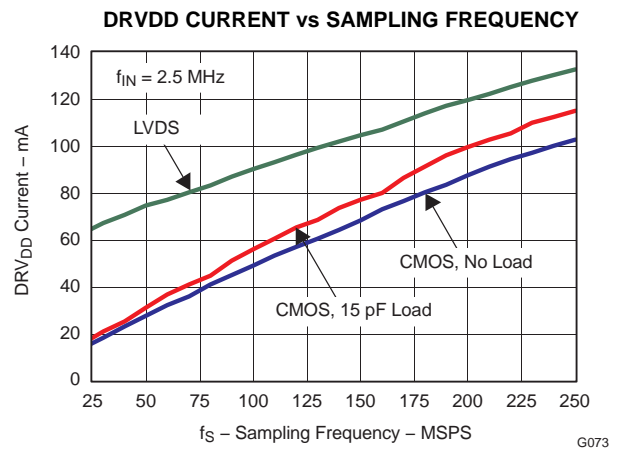
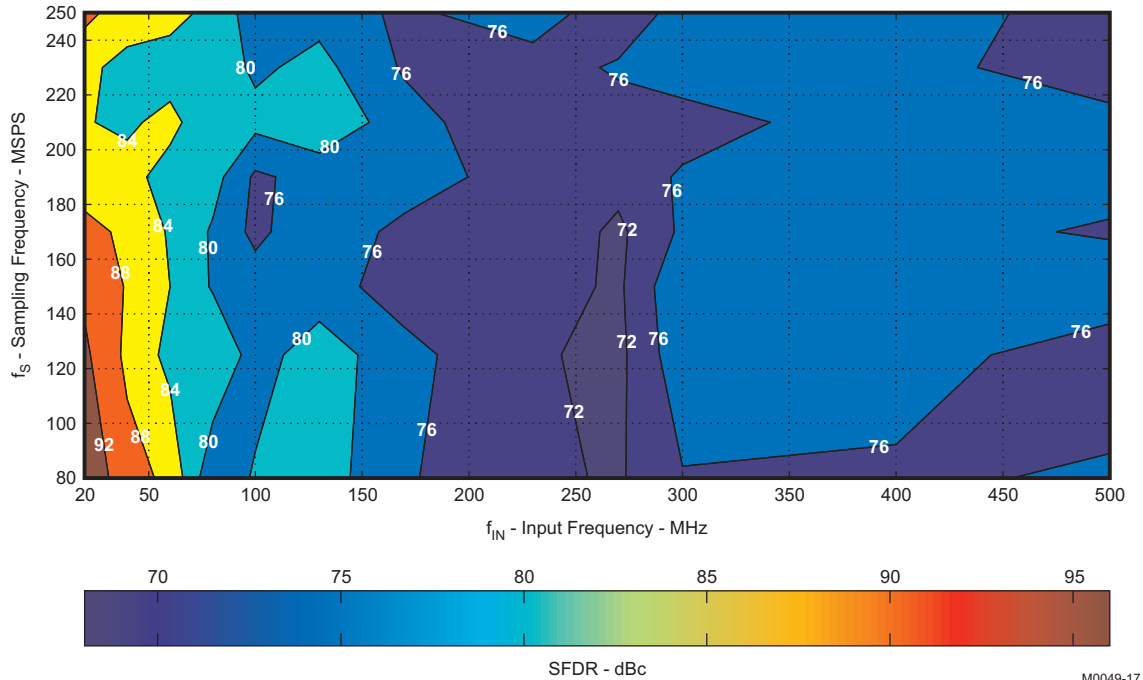

Figure 92.

**TYPICAL CHARACTERISTICS – ADS62P49/48/29/28**

All plots are at 25°C, AVDD = 3.3 V, DRVDD = 1.8 V, maximum rated sampling frequency, sine wave input clock. 1.5 V<sub>PP</sub> differential clock amplitude, 50% clock duty cycle, -1 dBFS differential analog input, internal reference mode, 0 dB gain, LVDS output interface, 32K point FFT (unless otherwise noted)

**SFDR CONTOUR, 0 dB GAIN, UP TO 500 MHz**



**Figure 93.**

**SFDR CONTOUR, 6 dB GAIN, UP TO 800 MHz**

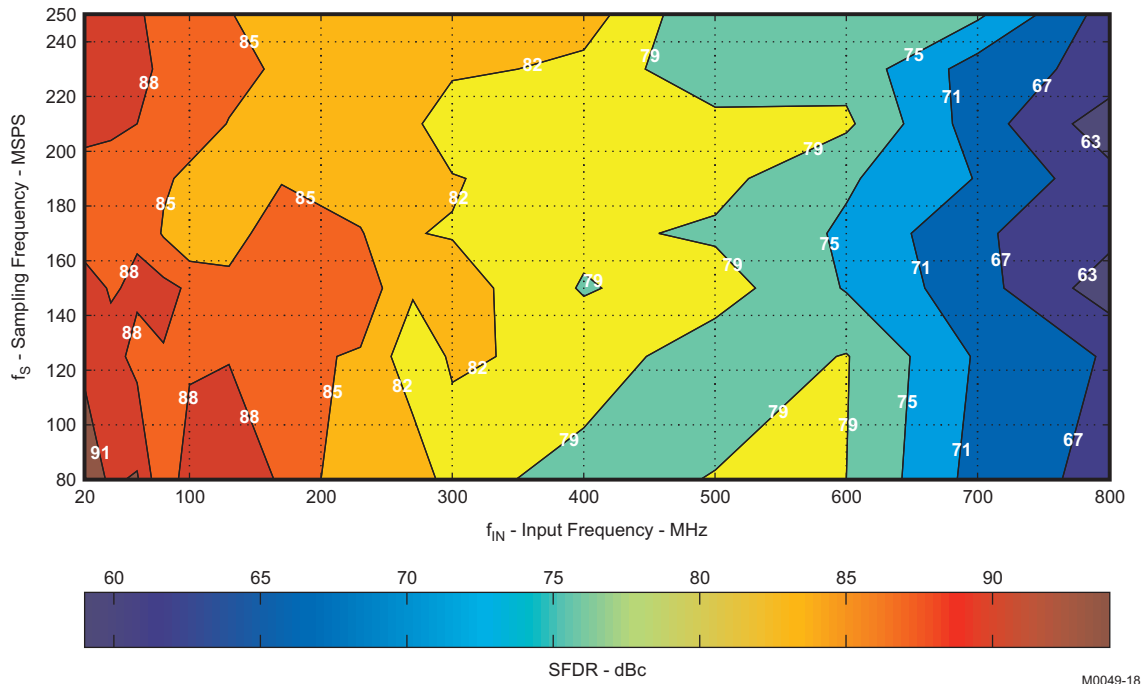
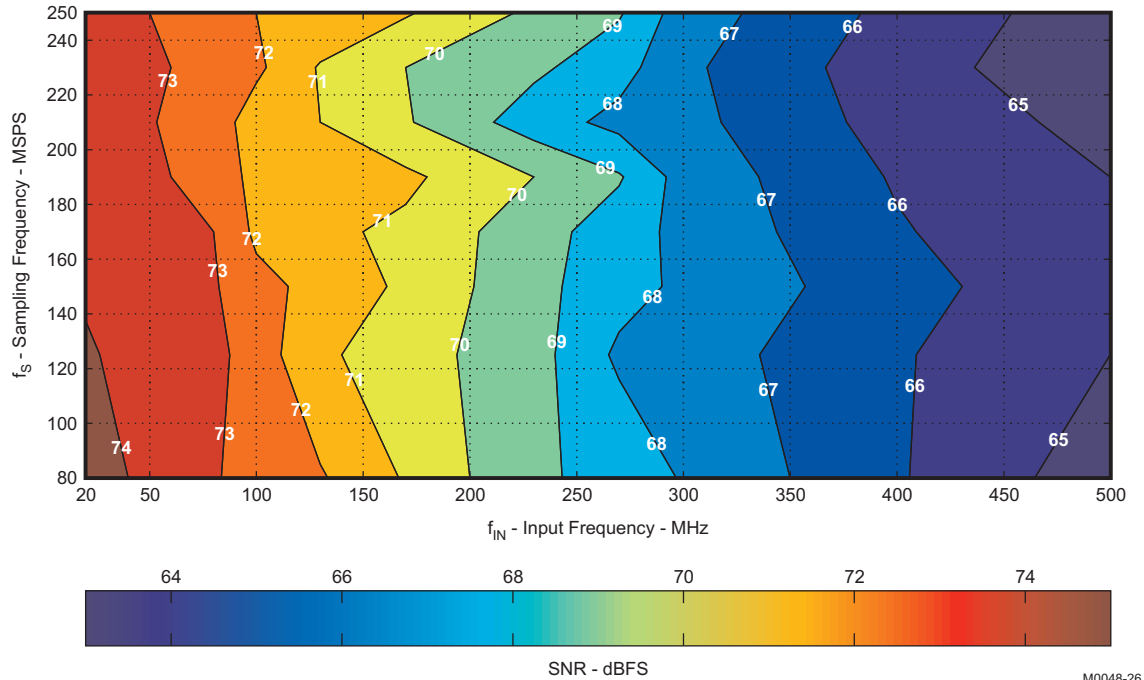

**Figure 94.**

**TYPICAL CHARACTERISTICS – ADS62P49/48**

All plots are at 25°C, AVDD = 3.3 V, DRVDD = 1.8 V, maximum rated sampling frequency, sine wave input clock. 1.5 V<sub>PP</sub> differential clock amplitude, 50% clock duty cycle, -1 dBFS differential analog input, internal reference mode, 0 dB gain, LVDS output interface, 32K point FFT (unless otherwise noted)

**SNR CONTOUR, 0 dB GAIN, UP TO 500 MHz**



**Figure 95.**

**SNR CONTOUR, 6 dB GAIN, UP TO 800 MHz**

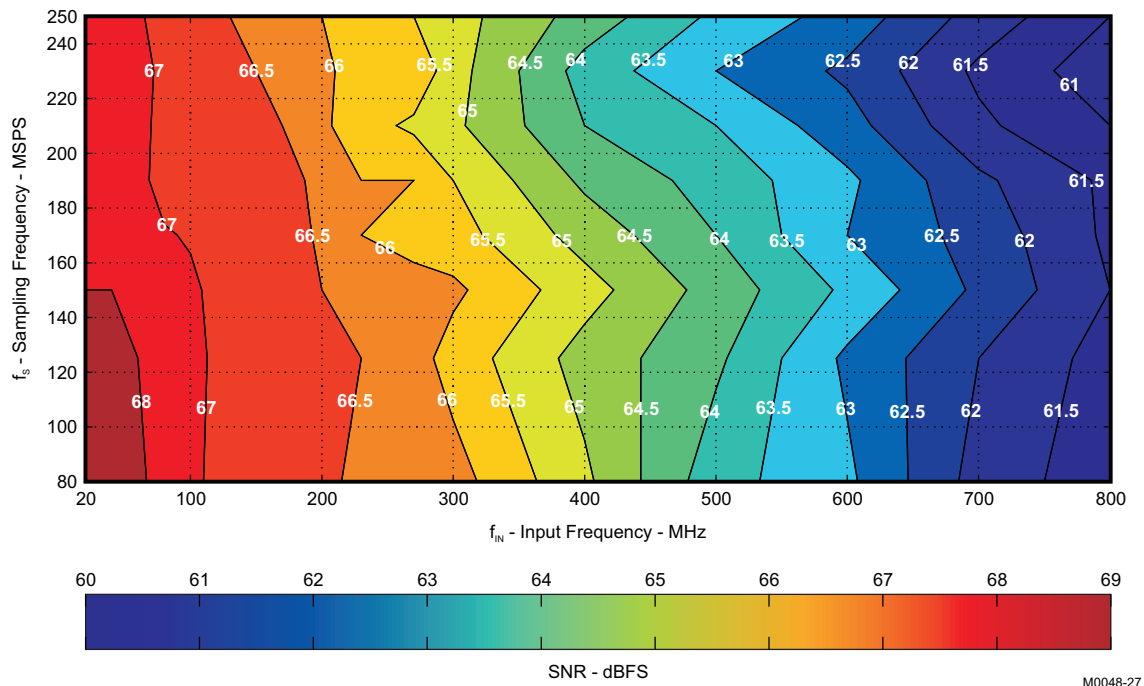
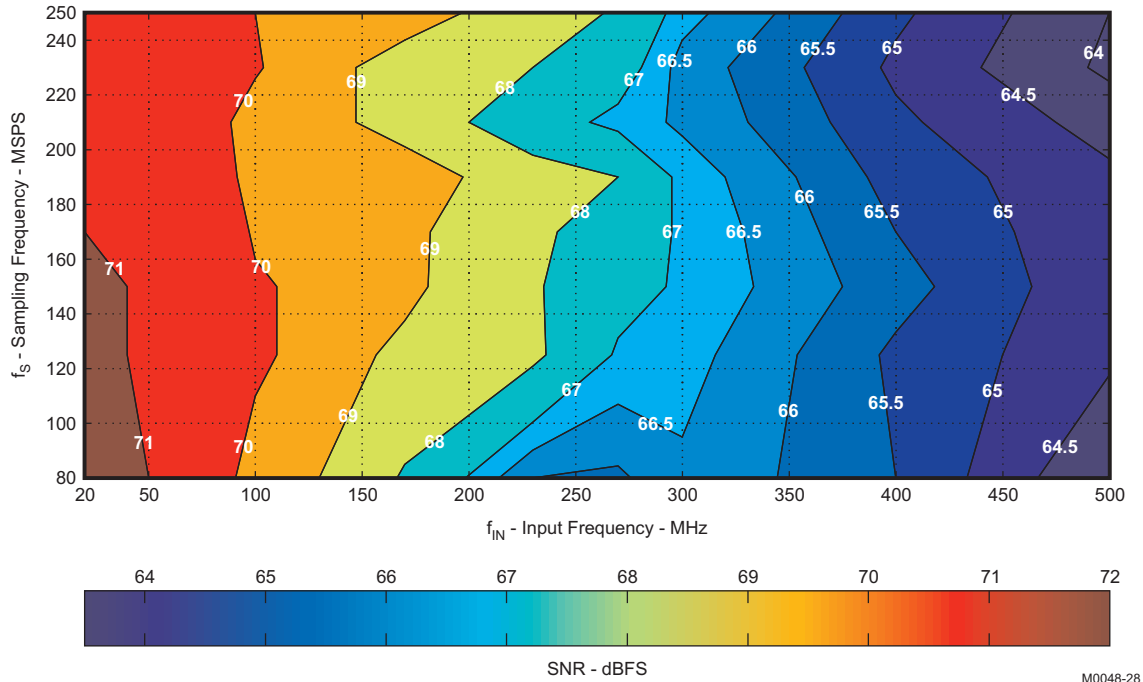

**Figure 96.**

**TYPICAL CHARACTERISTICS – ADS62P29/28**

All plots are at 25°C, AVDD = 3.3 V, DRVDD = 1.8 V, maximum rated sampling frequency, sine wave input clock. 1.5 V<sub>PP</sub> differential clock amplitude, 50% clock duty cycle, -1 dBFS differential analog input, internal reference mode, 0 dB gain, LVDS output interface, 32K point FFT (unless otherwise noted)

**SNR CONTOUR, 0 dB GAIN, UP TO 500 MHz**



**Figure 97.**

**SNR CONTOUR, 6 dB GAIN, UP TO 800 MHz**

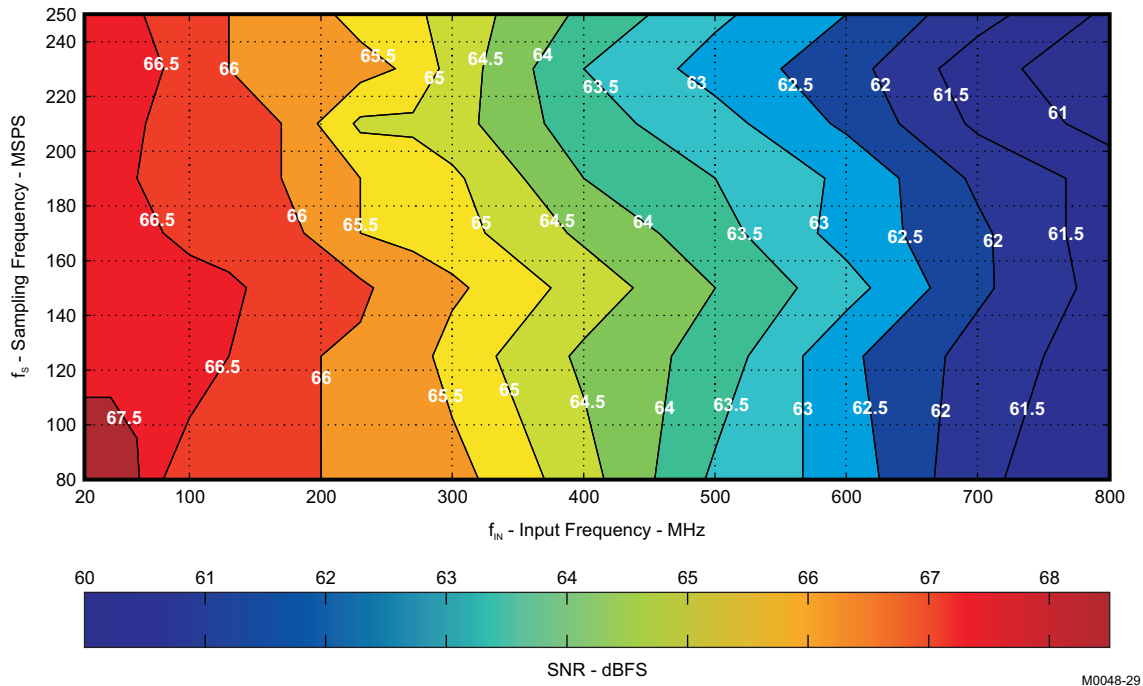

**Figure 98.**

## APPLICATION INFORMATION

### THEORY OF OPERATION

The ADS62Px9/x8 is a family of high performance and low power dual channel 14-bit/12-bit A/D converters with sampling rates up to 250 MSPS.

At every falling edge of the input clock, the analog input signal of each channel is sampled simultaneously. The sampled signal in each channel is converted by a pipeline of low resolution stages. In each stage, the sampled and held signal is converted by a high speed, low resolution flash sub-ADC. The difference (residue) between the stage input and its quantized equivalent is gained and propagates to the next stage.

At every clock, each succeeding stage resolves the sampled input with greater accuracy. The digital outputs from all stages are combined in a digital correction logic block and processed digitally to create the final code, after a data latency of 22 clock cycles.

The digital output is available as either DDR LVDS or parallel CMOS and coded in either straight offset binary or binary 2s complement format.

The dynamic offset of the first stage sub-ADC limits the maximum analog input frequency to about 500MHz (with 2V pp amplitude) and about 800MHz (with 1V pp amplitude).

### ANALOG INPUT

The analog input consists of a switched-capacitor based differential sample and hold architecture. This differential topology results in very good AC performance even for high input frequencies at high sampling rates. The INP and INM pins have to be externally biased around a common-mode voltage of 1.5V, available on VCM pin. For a full-scale differential input, each input pin INP, INM has to swing symmetrically between  $V_{CM} + 0.5V$  and  $V_{CM} - 0.5V$ , resulting in a 2Vpp differential input swing.

The input sampling circuit has a high 3-dB bandwidth that extends up to 700 MHz (measured from the input pins to the sampled voltage).

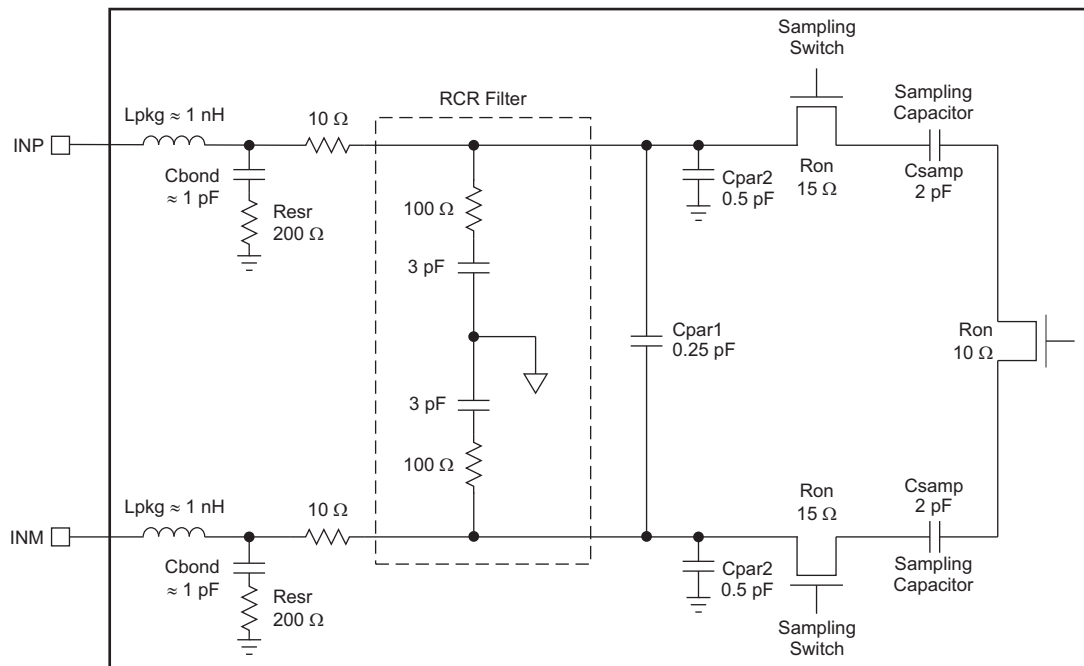

S0322-03

Figure 99. Analog Input Circuit

## Drive Circuit Requirements

For optimum performance, the analog inputs must be driven differentially. This improves the common-mode noise immunity and even order harmonic rejection. A 5-Ω to 15-Ω resistor in series with each input pin is recommended to damp out ringing caused by package parasitic.

SFDR performance can be limited due to several reasons - the effect of sampling glitches (described below), non-linearity of the sampling circuit and non-linearity of the quantizer that follows the sampling circuit. Depending on the input frequency, sample rate and input amplitude, one of these plays a dominant part in limiting performance.

At very high input frequencies (> about 300 MHz), SFDR is determined largely by the device's sampling circuit non-linearity. At low input amplitudes, the quantizer non-linearity usually limits performance.

Glitches are caused by the opening and closing of the sampling switches. The driving circuit should present a low source impedance to absorb these glitches. Otherwise, this could limit performance, mainly at low input frequencies (up to about 200 MHz). It is also necessary to present low impedance (< 50 Ω) for the common mode switching currents. This can be achieved by using two resistors from each input terminated to the common mode voltage (VCM).

The device includes an internal R-C filter from each input to ground. The purpose of this filter is to absorb the sampling glitches inside the device itself. The cut-off frequency of the R-C filter involves a trade-off. A lower cut-off frequency (larger C) absorbs glitches better, but it reduces the input bandwidth. On the other hand, with a higher cut-off frequency (smaller C), bandwidth support is maximized. But now, the sampling glitches need to be supplied by the external drive circuit. This has limitations due to the presence of the package bond-wire inductance.

In ADS62PXX, the R-C component values have been optimized while supporting high input bandwidth (up to 700 MHz). However, in applications with input frequencies up to 200-300MHz, the filtering of the glitches can be improved further using an external R-C-R filter (as shown in [Figure 102](#) and [Figure 103](#)).

In addition to the above, the drive circuit may have to be designed to provide a low insertion loss over the desired frequency range and matched impedance to the source. While doing this, the ADC input impedance must be considered. [Figure 100](#) and [Figure 101](#) show the impedance ( $Z_{in} = R_{in} \parallel C_{in}$ ) looking into the ADC input pins.

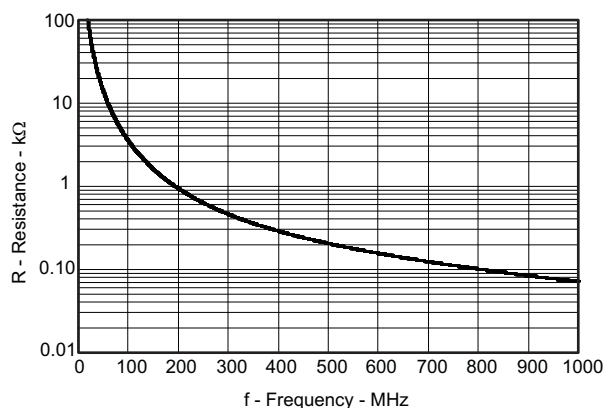

**Figure 100. ADC Analog Input Resistance ( $R_{in}$ ) Across Frequency**

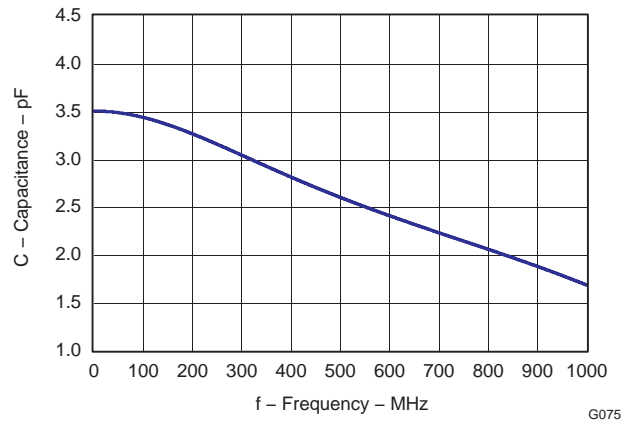

**Figure 101. ADC Analog Input Capacitance (C<sub>in</sub>) Across Frequency**

### Driving Circuit

Two example driving circuit configurations are shown in [Figure 102](#) and [Figure 103](#) one optimized for low bandwidth (low input frequencies) and the other one for high bandwidth to support higher input frequencies.

In [Figure 102](#), an external R-C-R filter using 22 pF has been used. Together with the series inductor (39 nH), this combination forms a filter and absorbs the sampling glitches. Due to the large capacitor (22 pF) in the R-C-R and the 15-Ω resistors in series with each input pin, the drive circuit has low bandwidth and supports low input frequencies (< 100MHz).

To support higher input frequencies (up to about 300 MHz, see [Figure 103](#)), the capacitance used in the R-C-R is reduced to 3.3 pF and the series inductors are shorted out. Together with the lower series resistors (5 Ω), this drive circuit provides high bandwidth and supports high input frequencies. Transformers such as ADT1-1WT or ETC1-1-13 can be used up to 300MHz.

Without the external R-C-R filter, the drive circuit has very high bandwidth and can support very high input frequencies (> 300MHz). For example, a transmission line transformer such as ADTL2-18 can be used (see [Figure 104](#)).

Note that both the drive circuits have been terminated by 50 Ω near the ADC side. The termination is accomplished by a 25-Ω resistor from each input to the 1.5-V common-mode (V<sub>CM</sub>) from the device. This allows the analog inputs to be biased around the required common-mode voltage.

The mismatch in the transformer parasitic capacitance (between the windings) results in degraded even-order harmonic performance. Connecting two identical RF transformers back to back helps minimize this mismatch and good performance is obtained for high frequency input signals. An additional termination resistor pair may be required between the two transformers as shown in the figures. The center point of this termination is connected to ground to improve the balance between the P and M side. The values of the terminations between the transformers and on the secondary side have to be chosen to get an effective 50 Ω (in the case of 50-Ω source impedance).

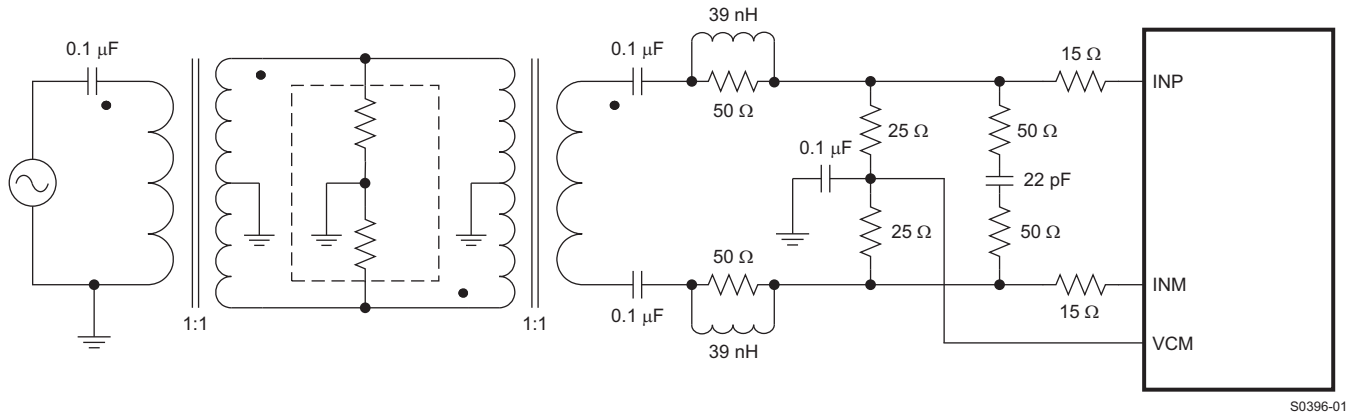

S0396-01

Figure 102. Drive Circuit With Low Bandwidth (for low input frequencies)

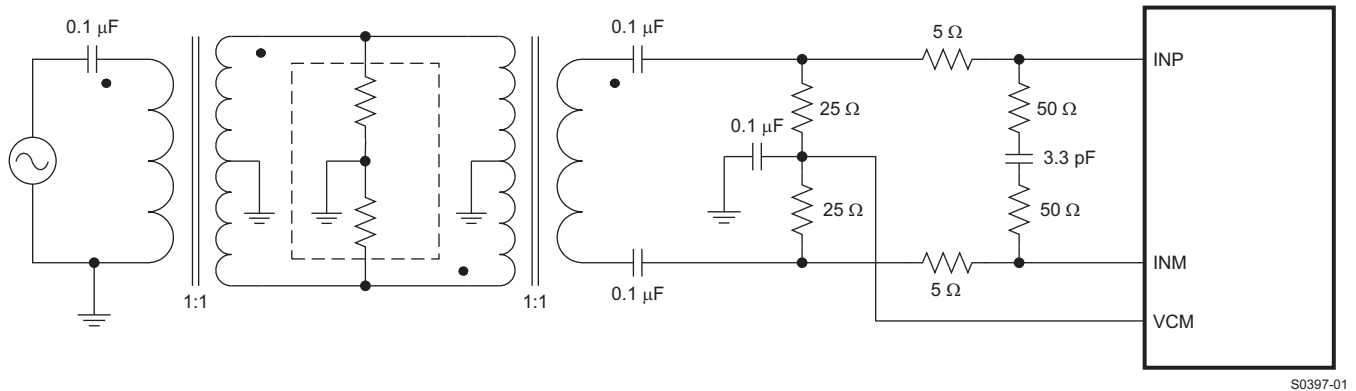

S0397-01

Figure 103. Drive Circuit With High Bandwidth (for high input frequencies)

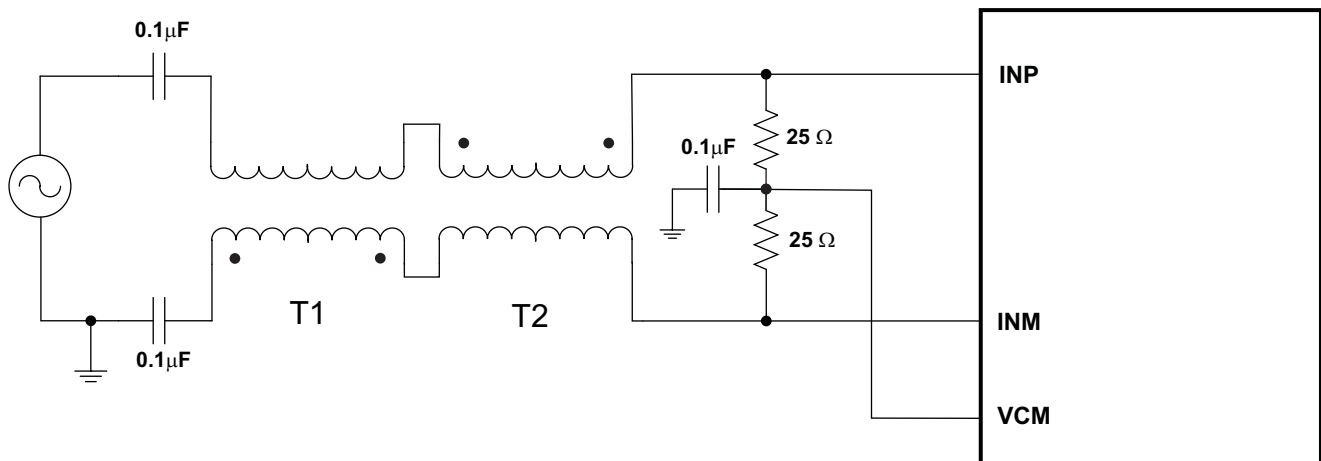

Figure 104. Drive Circuit with Very High Bandwidth (> 300 MHz)

All these examples show 1:1 transformers being used with a 50-Ω source. As explained in the “Drive Circuit Requirements”, this helps to present a low source impedance to absorb the sampling glitches. With a 1:4 transformer, the source impedance will be 200 ohms. The higher impedance can lead to degradation in performance, compared to the case with 1:1 transformers.

For applications where only a band of frequencies are used, the drive circuit can be tuned to present a low impedance for the sampling glitches. Figure 105 shows an example with 1:4 transformer, tuned for a band around 150 MHz.

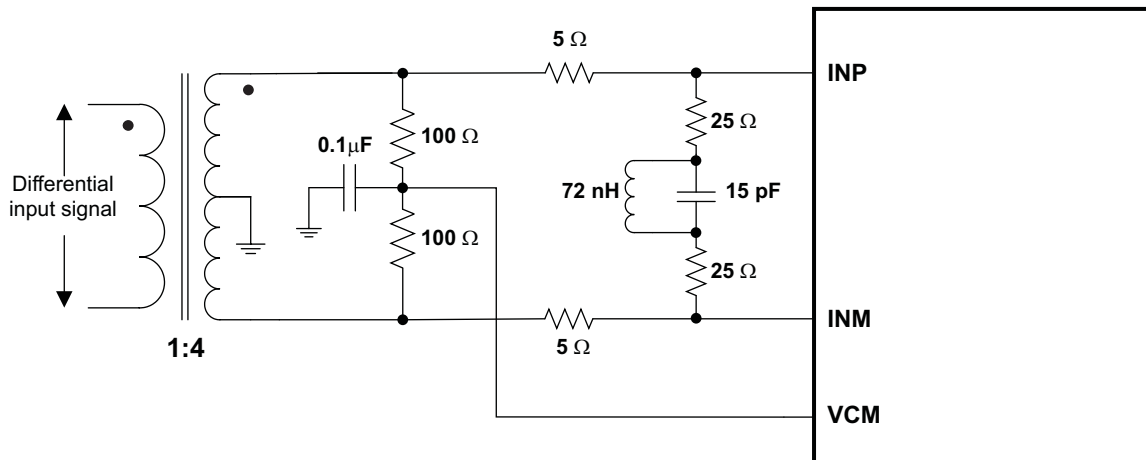

Figure 105. Drive Circuit with 1:4 Transformer

### Input Common-Mode

To ensure a low-noise common-mode reference, the VCM pin is filtered with a 0.1 μF low-inductance capacitor connected to ground. The VCM pin is designed to directly drive the ADC inputs. The input stage of the ADC sinks a common-mode current in the order of 3.6 μA / MSPS (about 900 μA at 250 MSPS).

### REFERENCE

The ADS62Px9/x8 has built-in internal references REFP and REFM, requiring no external components. Design schemes are used to linearize the converter load seen by the references; this and the on-chip integration of the requisite reference capacitors eliminates the need for external decoupling. The full-scale input range of the converter can be controlled in the external reference mode as explained below. The internal or external reference modes can be selected by programming the serial interface register bit <REF>.

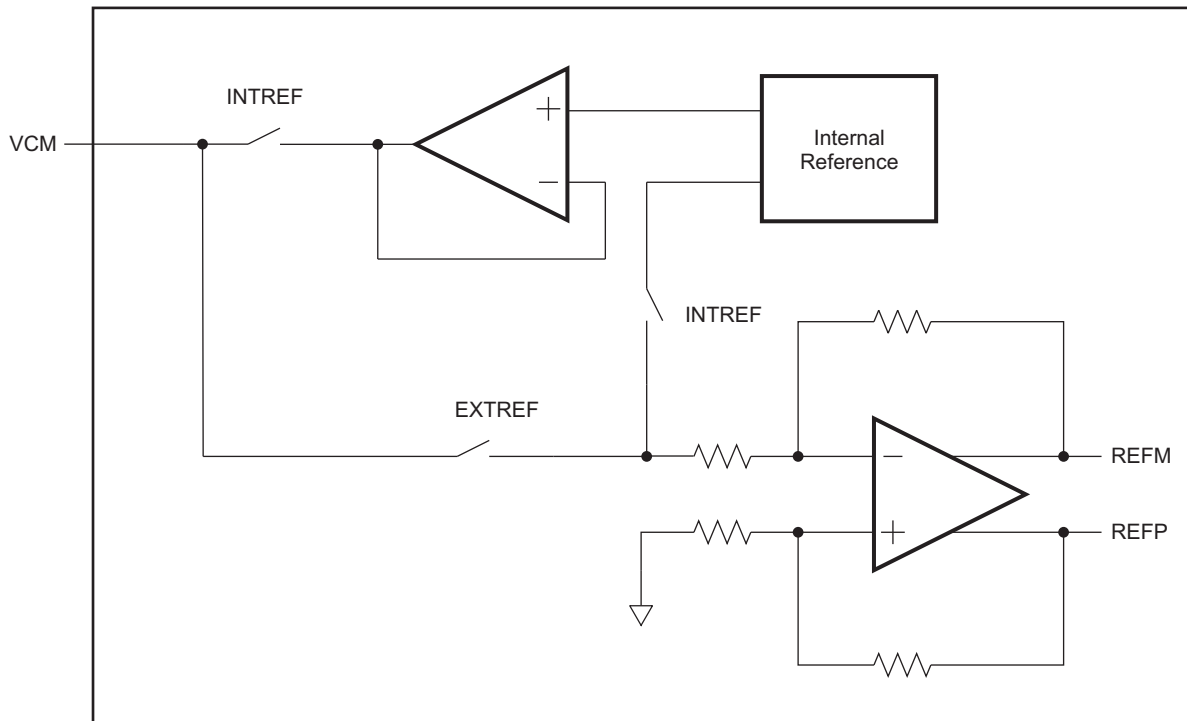

S0165-09

Figure 106. Reference Section

### Internal Reference

When the device is in internal reference mode, the REFP and REFM voltages are generated internally. Common-mode voltage (1.5V nominal) is output on VCM pin, which can be used to externally bias the analog input pins.

### External Reference

When the device is in external reference mode, the VCM acts as a reference input pin. The voltage forced on the VCM pin is buffered and gained by 1.33 internally, generating the REFP and REFM voltages. The differential input voltage corresponding to full-scale is given by the following:

$$\text{Full-scale differential input pp} = (\text{Voltage forced on VCM}) \times 1.33$$

In this mode, the 1.5V common-mode voltage to bias the input pins has to be generated externally.

### CLOCK INPUT

The ADS62Px9/x8 clock inputs can be driven differentially (sine, LVPECL or LVDS) or single-ended (LVCMOS), with little or no difference in performance between them. The common-mode voltage of the clock inputs is set to VCM using internal 5-k $\Omega$  resistors as shown in [Figure 107](#). This allows using transformer-coupled drive circuits for sine wave clock or ac-coupling for LVPECL, LVDS clock sources ([Figure 108](#), [Figure 109](#), and [Figure 110](#)).

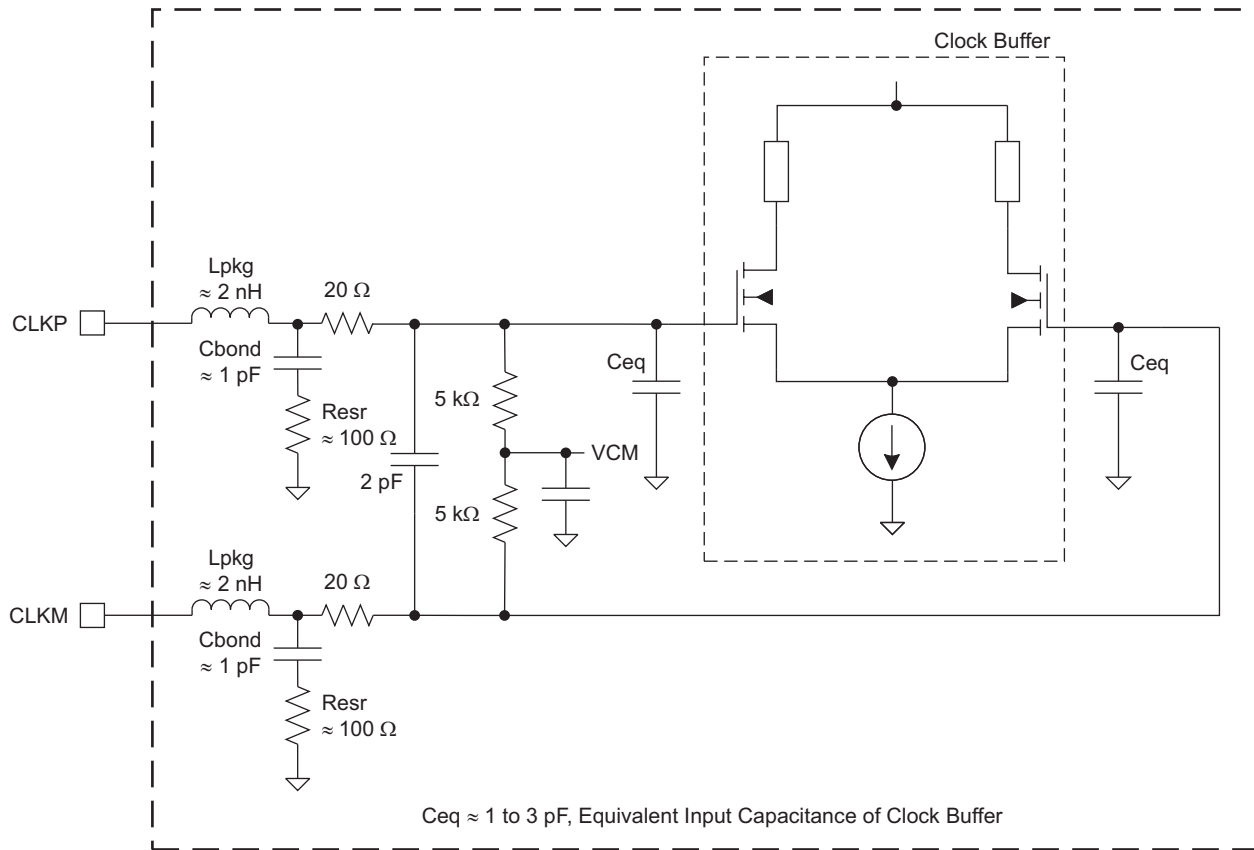

S0275-04

**Figure 107. Internal Clock Buffer**

Single-ended CMOS clock can be ac-coupled to the CLKP input, with CLKM (pin 11) connected to ground with a 0.1- $\mu$ F capacitor, as shown in Figure 111.

For best performance, the clock inputs have to be driven differentially, reducing susceptibility to common-mode noise. For high input frequency sampling, it is recommended to use a clock source with very low jitter. Bandpass filtering of the clock source can help reduce the effect of jitter. There is no change in performance with a non-50% duty cycle clock input.

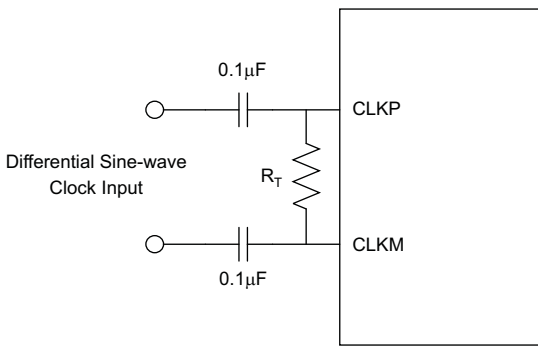

$R_T$  = termination resistor if necessary

**Figure 108. Differential Sine-Wave Clock Driving Circuit**

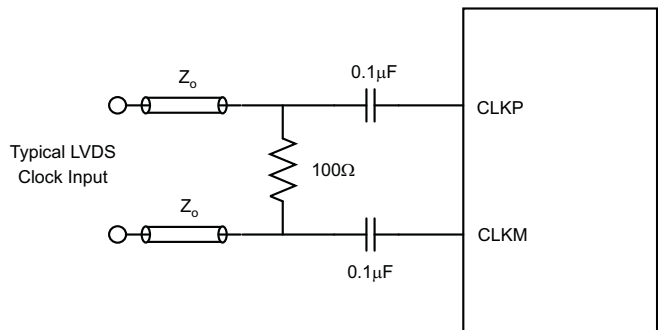

**Figure 109. Typical LVDS Clock Driving Circuit**

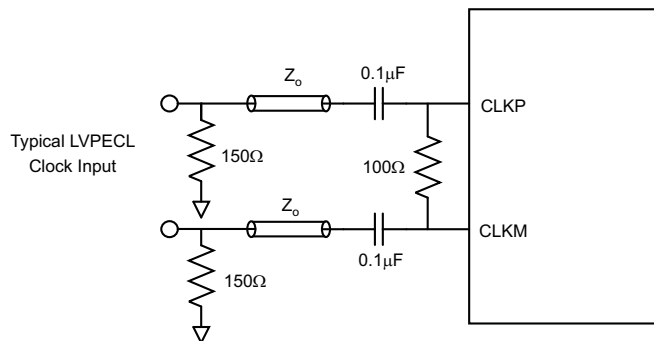

Figure 110. Typical LVPECL Clock Driving Circuit

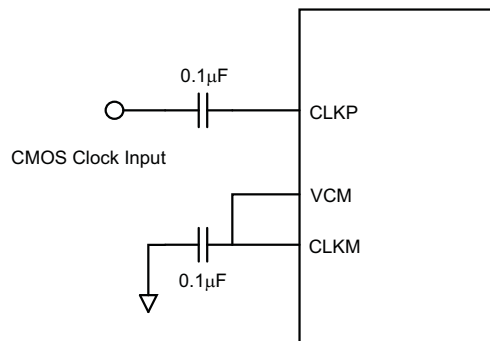

Figure 111. Typical LVCMOS Clock Driving Circuit

## GAIN PROGRAMMABILITY

The ADS62Px9/x8 includes gain settings that can be used to get improved SFDR performance (compared to no gain). The gain is programmable from 0dB to 6dB (in 0.5 dB steps). For each gain setting, the analog input full-scale range scales proportionally, as shown in [Table 9](#).

The SFDR improvement is achieved at the expense of SNR; for each 1dB gain step, the SNR degrades about 1dB. The SNR degradation is less at high input frequencies. As a result, the gain is very useful at high input frequencies as the SFDR improvement is significant with marginal degradation in SNR.

So, the gain can be used to trade-off between SFDR and SNR. Note that the default gain after reset is 0dB.

Table 9. Full-Scale Range Across Gains

GAIN, dB	TYPE	FULL-SCALE, V <sub>pp</sub>
0	Default after reset	2 V
1	Fine, programmable	1.78
2		1.59
3		1.42
4		1.26
5		1.12
6		1.00

## OFFSET CORRECTION

The ADS62Px9/x8 has an internal offset correction algorithm that estimates and corrects dc offset up to ±10mV. The correction can be enabled using the serial register bit **<ENABLE OFFSET CORRECTION>**. Once enabled, the algorithm estimates the channel offset and applies the correction every clock cycle. The time constant of the correction loop is a function of the sampling clock frequency. The time constant can be controlled using register bits **<OFFSET CORR TIME CONSTANT>** as described in [Table 10](#).

After the offset is estimated, the correction can be frozen by setting **<ENABLE OFFSET CORRECTION>** back to 0.

Once frozen, the last estimated value is used for offset correction every clock cycle. The correction does not affect the phase of the signal. Note that offset correction is disabled by default after reset.

[Figure 112](#) shows the time response of the offset correction algorithm, after it is enabled.

Table 10. Time Constant of Offset Correction Algorithm

<b>&lt;OFFSET CORR TIME CONSTANT&gt;</b> D3-D0	<b>TIME CONSTANT (TC<sub>CLK</sub>),</b> <b>NUMBER OF CLOCK CYCLES</b>	<b>TIME CONSTANT, sec</b> <b>(=TC<sub>CLK</sub> × 1/F<sub>s</sub>)<sup>(1)</sup></b>
0000	256 k	1 ms
0001	512 k	2 ms

(1) Sampling frequency, F<sub>s</sub> = 250 MSPS

Table 10. Time Constant of Offset Correction Algorithm (continued)

<OFFSET CORR TIME CONSTANT> D3-D0	TIME CONSTANT (TC <sub>CLK</sub> ), NUMBER OF CLOCK CYCLES	TIME CONSTANT, sec (=TC <sub>CLK</sub> × 1/Fs) <sup>(1)</sup>
0010	1 M	4 ms
0011	2 M	8 ms
0100	4 M	17 ms
0101	8 M	33 ms
0110	16 M	67 ms
0111	32 M	134 ms
1000	64 M	268 ms
1001	128 M	536 ms
1010	256 M	1.1 s
1011	512 M	2.2 s
1100	RESERVED	
1101	RESERVED	
1110	RESERVED	
1111	RESERVED	

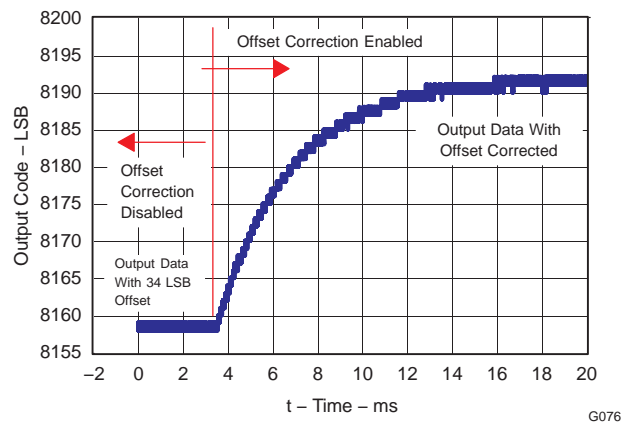

Figure 112. Time Response of Offset Correction

**POWER DOWN**

The ADS62Px9/x8 has two power down modes – global power down and individual channel standby. These can be set using either the serial register bits or using the control pins CTRL1 to CTRL3.

POWER DOWN MODES	CONFIGURE USING			WAKE-UP TIME	
	SERIAL INTERFACE	PARALLEL CONTROL PINS			
Normal operation	<POWER DOWN MODES> = 0000	low	low	low	–
Output buffer disabled for channel B	<POWER DOWN MODES> = 1001	Not Available			–
Output buffer disabled for channel A	<POWER DOWN MODES> = 1010	Not Available			–
Output buffer disabled for channel A and B	<POWER DOWN MODES> = 1011	Not Available			–
Global power down	<POWER DOWN MODES> = 1100	high	low	low	Slow (30 μs)
Channel B standby	<POWER DOWN MODES> = 1101	high	low	high	Fast (1 μs)
Channel A standby	<POWER DOWN MODES> = 1110	high	high	low	Fast (1 μs)

POWER DOWN MODES	CONFIGURE USING			WAKE-UP TIME	
	SERIAL INTERFACE	PARALLEL CONTROL PINS			
Multiplexed (MUX) mode – Output data of channel A and B is multiplexed and available on <b>DA13 to DA0</b> pins. <sup>(1)</sup>	<POWER DOWN MODES> = 1111	high	high	high	–

(1) Low Speed mode has to be enabled for Multiplexed Output mode (MUX mode). Therefore, MUX mode works with serial interface configuration only and is not supported with parallel configuration.

### Global Power Down

In this mode, the entire chip including both the A/D converters, internal reference and the output buffers are powered down resulting in reduced total power dissipation of about 45 mW. The output buffers are in high impedance state. The wake-up time from the global power down to data becoming valid in normal mode is typically 30µs.

### Channel Standby

Here, each channel's A/D converter can be powered down. The internal references are active, resulting in quick wake-up time of 1 µs. The total power dissipation in standby is about 475 mW.

### Input Clock Stop

In addition to the above, the converter enters a low-power mode when the input clock frequency falls below 1 MSPS. The power dissipation is about 275 mW.

### POWER SUPPLY SEQUENCE

During power-up, the AVDD and DRVDD supplies can come up in any sequence. The two supplies are separated in the device. Externally, they can be driven from separate supplies or from a single supply.

### DIGITAL OUTPUT INFORMATION

The ADS62Px9/x8 provides 14-bit/12-bit data and an output clock synchronized with the data.

### Output Interface

Two output interface options are available – Double Data Rate (DDR) LVDS and parallel CMOS. They can be selected using the serial interface register bit <LVDS\_CMOS> or using DFS pin in parallel configuration mode.

### DDR LVDS Outputs

In this mode, the data bits and clock are output using LVDS (Low Voltage Differential Signal) levels. Two data bits are multiplexed and output on each LVDS differential pair.

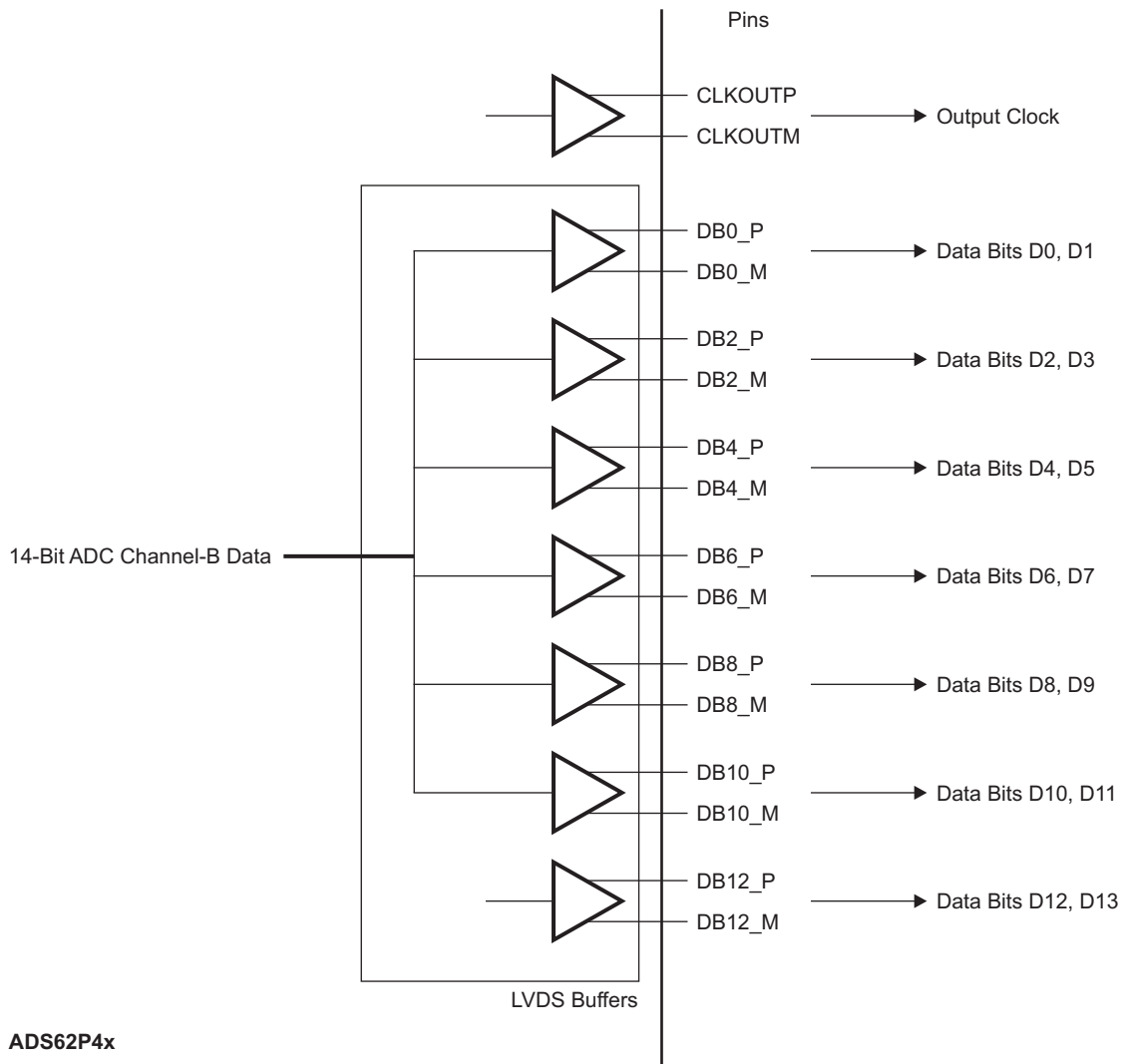

S0398-01

Figure 113. LVDS Outputs

Even data bits D0, D2, D4... are output at the rising edge of CLKOUTP and the odd data bits D1, D3, D5... are output at the falling edge of CLKOUTP. Both the rising and falling edges of CLKOUTP have to be used to capture all the data bits (see Figure 114).

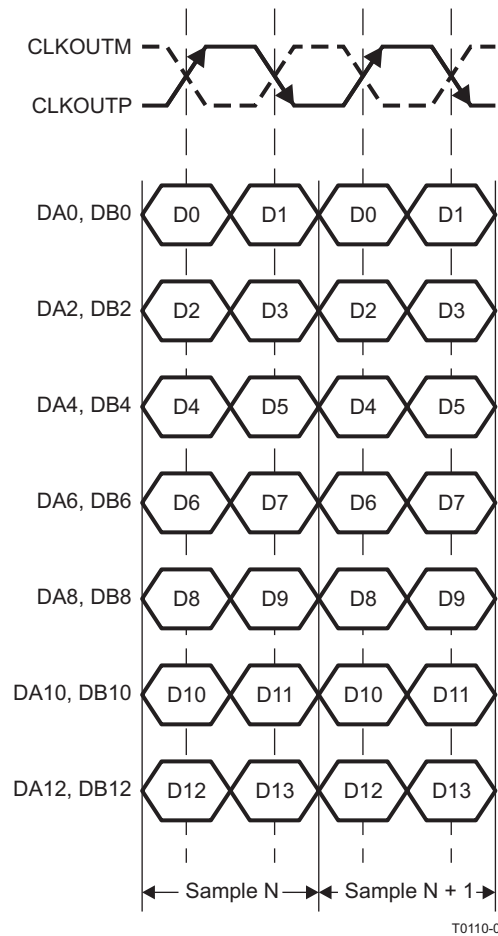
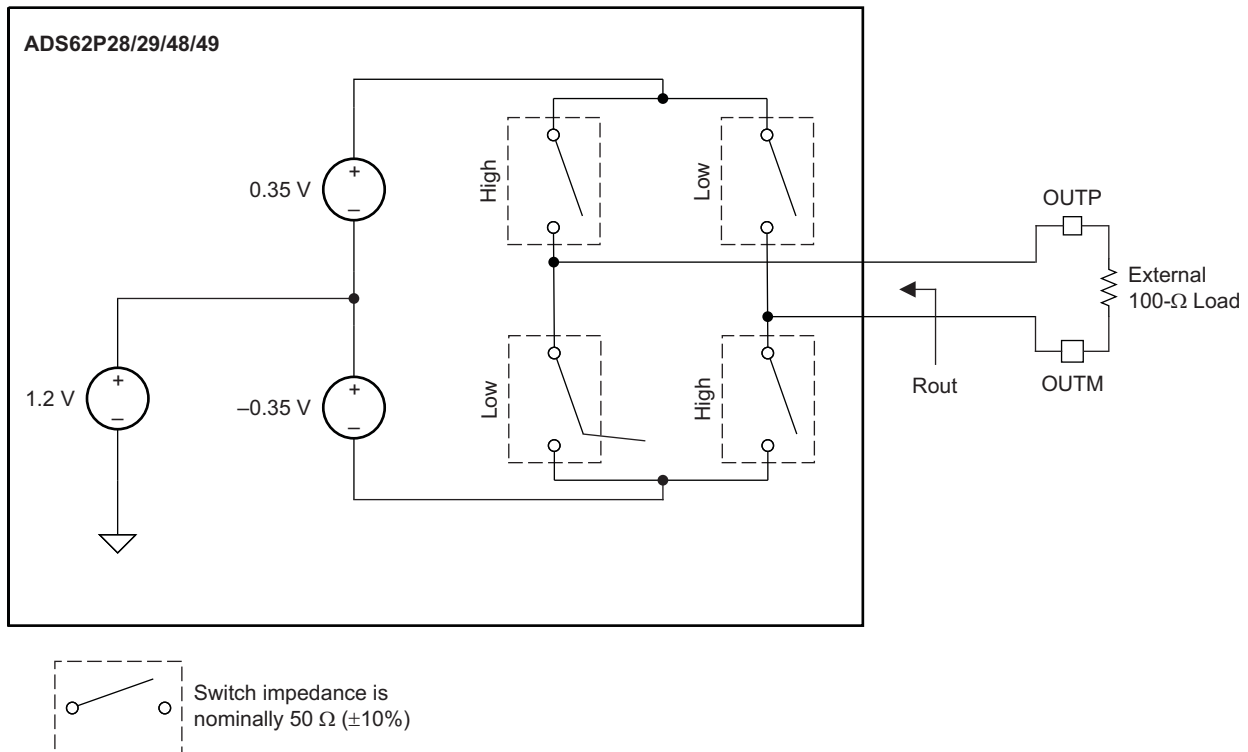

**Figure 114. DDR LVDS Interface**

### LVDS Buffer

The equivalent circuit of each LVDS output buffer is shown in [Figure 115](#). The buffer is designed to present an output impedance of 100  $\Omega$  ( $R_{out}$ ). The differential outputs can be terminated at the receive end by a 100- $\Omega$  termination.

The buffer output impedance behaves like a source-side series termination. By absorbing reflections from the receiver end, it helps to improve signal integrity. Note that this internal termination cannot be disabled and its value cannot be changed.



When the High switches are closed,  $OUTP = 1.375\text{ V}$ ,  $OUTM = 1.025\text{ V}$   
 When the Low switches are closed,  $OUTP = 1.025\text{ V}$ ,  $OUTM = 1.375\text{ V}$   
 When the High (or Low) switches are closed,  $R_{out} = 100\ \Omega$

S0374-03

**Figure 115. LVDS Buffer Equivalent Circuit**

### Parallel CMOS Interface

In CMOS mode, each data bit is output on a separate pin as a CMOS voltage level, every clock cycle. This mode is recommended only up to 210 MSPS, beyond which the CMOS data outputs do not have sufficient time to settle to valid logic levels.

For sampling frequencies up to 150 MSPS, the rising edge of the output clock CLKOUT can be used to latch data in the receiver. The setup and hold timings of the output data with respect to CLKOUT are specified in the timing specification table up to 150 MSPS.

For sampling frequencies above 150 MSPS, it is recommended to use an external clock to capture data. The delay from input clock to output data and the data valid times are specified up to 210 MSPS. These timings can be used to delay the input clock appropriately and use it to capture the data.

When using the CMOS interface, it is important to minimize the load capacitance seen by data and clock output pins by using short traces on the board.

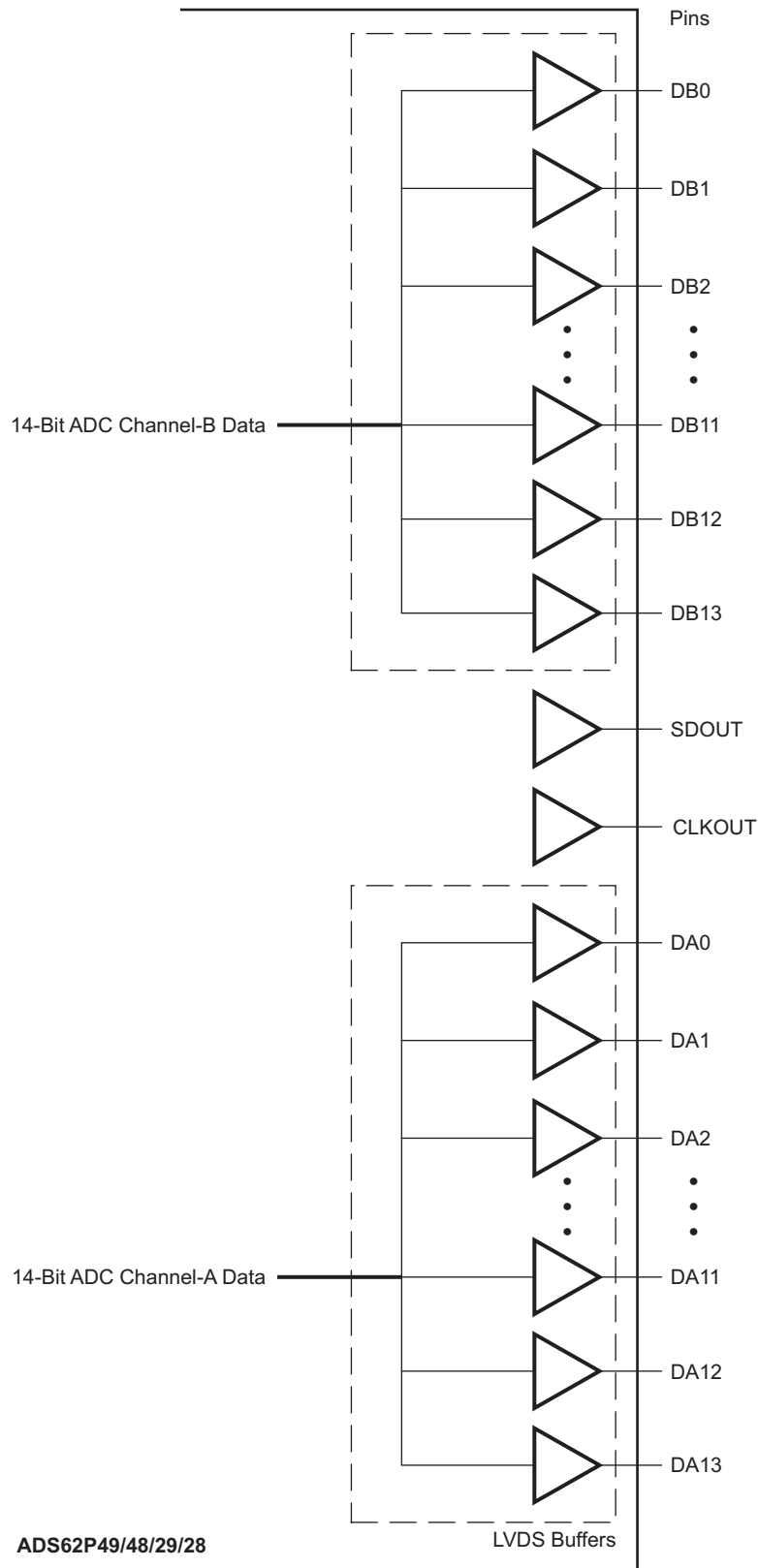

S0399-01

Figure 116. CMOS Outputs

### CMOS Interface Power Dissipation

With CMOS outputs, the DRVDD current scales with the sampling frequency and the load capacitance on every output pin. The maximum DRVDD current occurs when each output bit toggles between 0 and 1 every clock cycle. In actual applications, this condition is unlikely to occur. The actual DRVDD current would be determined by the average number of output bits switching, which is a function of the sampling frequency and the nature of the analog input signal.

$$\text{Digital current due to CMOS output switching} = C_L \times \text{DRVDD} \times (N \times F_{\text{AVG}}),$$

where

$C_L$  = load capacitance,

$N \times F_{\text{AVG}}$  = average number of output bits switching.

Figure 92 shows the current with various load capacitances across sampling frequencies at 2.5-MHz analog input frequency

### Multiplexed Output Mode (only with CMOS interface)

In this mode, the digital outputs of both channels are multiplexed and output on a single bus (DA0-DA13 pins). Channel B data bits are output at the rising edge of CLKOUT, and channel A data bits are output at the falling edge of CLKOUT. The channel B output data pins (DB0-DB13) are 3-stated (see Figure 117 for details). Since the output data rate on the DA bus is effectively doubled, this mode is recommended only for low sampling frequencies (<65MSPS).

Low Speed mode has to be enabled for Multiplexed Output Mode (MUX mode). Therefore, MUX mode works with serial interface configuration only and is not supported with parallel configuration. This mode can be enabled using register bits <POWER DOWN MODES> or using the parallel pins CTRL1-3.

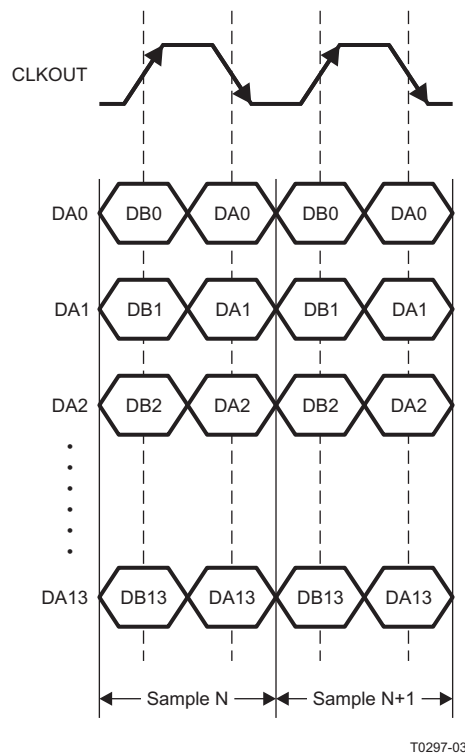

- NOTES: 1. Both channel outputs are output on the channel A output data lines.  
2. Channel A outputs are output on the falling edges whereas channel B outputs are output on the rising edges of the output clock.

Figure 117. Multiplexed Output Mode Timing

## Output Data Format

Two output data formats are supported – 2s complement and offset binary. They can be selected using the serial interface register bit **<DATA FORMAT>** or controlling the DFS pin in parallel configuration mode.

In the event of an input voltage overdrive, the digital outputs go to the appropriate full scale level. For a positive overdrive, the output code is 0x3FFF in offset binary output format, and 0x1FFF in 2s complement output format. For a negative input overdrive, the output code is 0x0000 in offset binary output format and 0x2000 in 2s complement output format.

## BOARD DESIGN CONSIDERATIONS

### Grounding

A single ground plane is sufficient to give good performance, provided the analog, digital, and clock sections of the board are cleanly partitioned. See the EVM User Guide ([SLAU237](#)) for details on layout and grounding.

### Supply Decoupling

As ADS62Px9/x8 already includes internal decoupling, minimal external decoupling can be used without loss in performance. Note that decoupling capacitors can help filter external power supply noise, so the optimum number of capacitors would depend on the actual application. The decoupling capacitors should be placed very close to the converter supply pins.

### Exposed Pad

In addition to providing a path for heat dissipation, the pad is also electrically connected to digital ground internally. So, it is necessary to solder the exposed pad to the ground plane for best thermal and electrical performance. For detailed information, see application notes *QFN Layout Guidelines* ([SLOA122](#)) and *QFN/SON PCB Attachment* ([SLUA271](#)).

## DEFINITION OF SPECIFICATIONS

**Analog Bandwidth** – The analog input frequency at which the power of the fundamental is reduced by 3 dB with respect to the low frequency value.

**Aperture Delay** – The delay in time between the rising edge of the input sampling clock and the actual time at which the sampling occurs. This delay will be different across channels. The maximum variation is specified as aperture delay variation (channel-channel).

**Aperture Uncertainty (Jitter)** – The sample-to-sample variation in aperture delay.

**Clock Pulse Width/Duty Cycle** – The duty cycle of a clock signal is the ratio of the time the clock signal remains at a logic high (clock pulse width) to the period of the clock signal. Duty cycle is typically expressed as a percentage. A perfect differential sine-wave clock results in a 50% duty cycle.

**Maximum Conversion Rate** – The maximum sampling rate at which certified operation is given. All parametric testing is performed at this sampling rate unless otherwise noted.

**Minimum Conversion Rate** – The minimum sampling rate at which the ADC functions.

**Differential Nonlinearity (DNL)** – An ideal ADC exhibits code transitions at analog input values spaced exactly 1 LSB apart. The DNL is the deviation of any single step from this ideal value, measured in units of LSBs.

**Integral Nonlinearity (INL)** – The INL is the deviation of the ADC's transfer function from a best fit line determined by a least squares curve fit of that transfer function, measured in units of LSBs.

**Gain Error** – Gain error is the deviation of the ADC's actual input full-scale range from its ideal value. The gain error is given as a percentage of the ideal input full-scale range. Gain error has two components: error due to reference inaccuracy and error due to the channel. Both these errors are specified independently as  $E_{GREF}$  and  $E_{GCHAN}$ .

To a first order approximation, the total gain error will be  $E_{TOTAL} \sim E_{GREF} + E_{GCHAN}$ .

For example, if  $E_{TOTAL} = \pm 0.5\%$ , the full-scale input varies from  $(1 - 0.5/100) \times FS_{ideal}$  to  $(1 + 0.5/100) \times FS_{ideal}$ .

**Offset Error** – The offset error is the difference, given in number of LSBs, between the ADC's actual average idle channel output code and the ideal average idle channel output code. This quantity is often mapped into mV.

**Temperature Drift** – The temperature drift coefficient (with respect to gain error and offset error) specifies the change per degree Celsius of the parameter from  $T_{MIN}$  to  $T_{MAX}$ . It is calculated by dividing the maximum deviation of the parameter across the  $T_{MIN}$  to  $T_{MAX}$  range by the difference  $T_{MAX} - T_{MIN}$ .

**Signal-to-Noise Ratio** – SNR is the ratio of the power of the fundamental (PS) to the noise floor power (PN), excluding the power at DC and the first nine harmonics.

$$SNR = 10 \log_{10} \frac{P_S}{P_N} \quad (1)$$

SNR is either given in units of dBc (dB to carrier) when the absolute power of the fundamental is used as the reference, or dBFS (dB to full scale) when the power of the fundamental is extrapolated to the converter's full-scale range.

**Signal-to-Noise and Distortion (SINAD)** – SINAD is the ratio of the power of the fundamental ( $P_S$ ) to the power of all the other spectral components including noise ( $P_N$ ) and distortion ( $P_D$ ), but excluding dc.

$$SINAD = 10 \log_{10} \frac{P_S}{P_N + P_D} \quad (2)$$

SINAD is either given in units of dBc (dB to carrier) when the absolute power of the fundamental is used as the reference, or dBFS (dB to full scale) when the power of the fundamental is extrapolated to the converter's full-scale range.

**Effective Number of Bits (ENOB)** – The ENOB is a measure of the converter performance as compared to the theoretical limit based on quantization noise.

$$\text{ENOB} = \frac{\text{SINAD} - 1.76}{6.02} \quad (3)$$

**Total Harmonic Distortion (THD)** – THD is the ratio of the power of the fundamental ( $P_S$ ) to the power of the first nine harmonics ( $P_N$ ).

$$\text{THD} = 10 \log^{10} \frac{P_S}{P_N} \quad (4)$$

THD is typically given in units of dBc (dB to carrier).

**Spurious-Free Dynamic Range (SFDR)** – The ratio of the power of the fundamental to the highest other spectral component (either spur or harmonic). SFDR is typically given in units of dBc (dB to carrier).

**Two-Tone Intermodulation Distortion** – IMD3 is the ratio of the power of the fundamental (at frequencies  $f_1$  and  $f_2$ ) to the power of the worst spectral component at either frequency  $2f_1 - f_2$  or  $2f_2 - f_1$ . IMD3 is either given in units of dBc (dB to carrier) when the absolute power of the fundamental is used as the reference, or dBFS (dB to full scale) when the power of the fundamental is extrapolated to the converter's full-scale range.

**DC Power Supply Rejection Ratio (DC PSRR)** – The DC PSRR is the ratio of the change in offset error to a change in analog supply voltage. The DC PSRR is typically given in units of mV/V.

**AC Power Supply Rejection Ratio (AC PSRR)** – AC PSRR is the measure of rejection of variations in the supply voltage by the ADC. If  $\Delta V_{SUP}$  is the change in supply voltage and  $\Delta V_{OUT}$  is the resultant change of the ADC output code (referred to the input), then

$$\text{PSRR} = 20 \log^{10} \frac{\Delta V_{OUT}}{\Delta V_{SUP}} \quad (\text{Expressed in dBc}) \quad (5)$$

**Voltage Overload Recovery** – The number of clock cycles taken to recover to less than 1% error after an overload on the analog inputs. This is tested by separately applying a sine wave signal with 6dB positive and negative overload. The deviation of the first few samples after the overload (from their expected values) is noted.

**Common Mode Rejection Ratio (CMRR)** – CMRR is the measure of rejection of variation in the analog input common-mode by the ADC. If  $\Delta V_{cm\_in}$  is the change in the common-mode voltage of the input pins and  $\Delta V_{OUT}$  is the resultant change of the ADC output code (referred to the input), then

$$\text{CMRR} = 20 \log^{10} \frac{\Delta V_{OUT}}{\Delta V_{CM}} \quad (\text{Expressed in dBc}) \quad (6)$$

**Cross-Talk (only for multi-channel ADC)**– This is a measure of the internal coupling of a signal from adjacent channel into the channel of interest. It is specified separately for coupling from the immediate neighboring channel (near-channel) and for coupling from channel across the package (far-channel). It is usually measured by applying a full-scale signal in the adjacent channel. Cross-talk is the ratio of the power of the coupling signal (as measured at the output of the channel of interest) to the power of the signal applied at the adjacent channel input. It is typically expressed in dBc.

## REVISION HISTORY

Changes from Original (April 2009) to Revision A	Page
• Changed ADS62P48, ADS62P29, ADS62P28 from product preview to production data .....	4
• Added Analog supply current max value of 320 mA .....	7
• Added Output buffer supply current, LVDS interface max value of 165 mA .....	7
• Added Analog power max value of 1.05 W .....	7
• Added Digital power, LVDS interface max value of 0.3 W .....	7
• Added SNR Signal to noise ratio, LVDS, Fin = 170 MHz, 0 dB gain min value of 68 dBFS .....	8
• Added SINAD Signal to noise and distortion ratio, LVDS, Fin = 170 MHz, 0 dB gain min value of 66.5 dBFS .....	8
• Added SNR Signal to noise ratio, LVDS, Fin = 170 MHz, 0 dB gain min value of 66.5 dBFS .....	8
• Added SNR Signal to noise ratio, LVDS, Fin = 170 MHz, 0 dB gain min value of 66.5 dBFS .....	8
• Added SINAD Signal to noise and distortion ratio, LVDS, Fin = 170 MHz, 0 dB gain min value of 66 dBFS .....	8
• Added SINAD Signal to noise and distortion ratio, LVDS, Fin = 170 MHz, 0 dB gain min value of 66 dBFS .....	8
• Added DNL Differential non-linearity min value of –0.9 LSB .....	8
• Added DNL Differential non-linearity max value of 1.3 LSB .....	8
• Added DNL Differential non-linearity min value of –0.9 LSB .....	8
• Added DNL Differential non-linearity max value of 1.3 LSB .....	8
• Added INL Integrated non-linearity min value of –5 LSB .....	8
• Added INL Integrated non-linearity max value of 5 LSB .....	8
• Added INL Integrated non-linearity min value of –5 LSB .....	8
• Added INL Integrated non-linearity max value of 5 LSB .....	8
• Added SFDR Spurious Free Dynamic Range, Fin = 170 MHz min value of 71 dBc .....	9
• Added SFDR Spurious Free Dynamic Range, excluding HD2, HD3, Fin = 170 MHz min value of 78 dBc .....	9
• Added HD2 Second Harmonic Distortion, Fin = 170 MHz min value of 71 dBc .....	9
• Added HD3 Third Harmonic Distortion, Fin = 170 MHz min value of 71 dBc .....	9
• Added THD Total harmonic distortion, Fin = 170 MHz min value of 70.5 dBc .....	9
• Added IMD2-Tone Inter-modulation Distortion, F1 = 46 MHz, F2 = 50 MHz, each tone at –7 dBFS typ value of 91 dBFS .....	9

Changes from Revision A (June 2009) to Revision B	Page
• Changed Voltage between AVDD to DRVDD in ABSOLUTE MAXIMUM RATINGS .....	4
• Changed Voltage between DRVDD to AVDD in ABSOLUTE MAXIMUM RATINGS .....	4
• Added new thermal table .....	6
• Added table note 2 .....	6
• Added table notes 5 and 6 and Figure 3 .....	6
• Changed Sine wave, ac-coupled, TYP from 3 to 1.5 V <sub>PP</sub> .....	6
• Added <a href="#">Figure 3</a> .....	6
• Changed Digital Characteristics - ADS62Px9/x8 table note 2 .....	10
• Added table note to Timing Requirements table in row t <sub>OE</sub> .....	12
• Added table note 1 to <a href="#">Table 2</a> and <a href="#">Table 3</a> .....	12
• Added for Fs ≤ 80 to <a href="#">Table 2</a> and <a href="#">Table 3</a> .....	12
• Changed To put the device in parallel configuration mode, keep RESET tied to <b>high</b> (AVDD). to To put the device in parallel configuration mode, keep RESET tied to <b>high</b> (AVDD or DRVDD). in PARALLEL CONFIGURATION ONLY section .....	15
• Changed <a href="#">Table 4</a> .....	15

• Deleted 2 in <a href="#">Table 5</a> .....	15
• Changed <a href="#">Table 6</a> .....	16
• Added note to <a href="#">Table 7</a> and changed rows to Not available .....	16
• Changed sampling frequency from 100 MSPS to 80 MSPS in serial register 20 .....	22
• Added 00 and 10 to D6-D5 of serial register 3F .....	22
• Added reference to the Multiplexed Output Mode section in the APPLICATION INFORMATION .....	22
• Changed Serial register 44 description .....	23
• Added <a href="#">Figure 12</a> .....	24
• Added <a href="#">Figure 13</a> .....	24
• Added information to serial register 62 D2-D0 test patterns .....	27
• Added <a href="#">Figure 14</a> .....	28
• Added <a href="#">Figure 15</a> .....	29
• Added <a href="#">Figure 16</a> .....	30
• Added information to serial register 75 D2-D0 test patterns .....	33
• Changed DRVDD to AVDD in Pin Assignments (LVDS MODE) pin 15 description .....	37
• Added to Pin Assignments (LVDS MODE) pin 37 description .....	37
• Deleted true from DA and DB descriptions in Pin Assignments (LVDS MODE) .....	37
• Changed SDATA to SCLK in Pin Assignments (CMOS MODE) pin 12 description .....	40
• Changed DRVDD to AVDD in Pin Assignments (CMOS MODE) pin 15 description .....	40
• Added to Pin Assignments (CMOS MODE) pin 37 description .....	40
• Changed CMSO mode CLKOUT pin number from 5 to 57 .....	40
• Changed <a href="#">Figure 96</a> .....	55
• Changed <a href="#">Figure 98</a> .....	56
• Changed <a href="#">Figure 108</a> .....	63
• Changed <a href="#">Figure 109</a> .....	63
• Added <a href="#">Figure 110</a> .....	63
• Added <a href="#">Figure 111</a> .....	63
• Changed Power Down Modes table and added note .....	65
• Changed <a href="#">Figure 115</a> .....	69
• Added Multiplexed Output Mode (only with CMOS interface) section information .....	71

**PACKAGING INFORMATION**

Orderable Device	Status (1)	Package Type	Package Drawing	Pins	Package Qty	Eco Plan (2)	Lead/Ball Finish (6)	MSL Peak Temp (3)	Op Temp (°C)	Device Marking (4/5)	Samples
ADS62P28IRGCR	ACTIVE	VQFN	RGC	64	2000	Green (RoHS & no Sb/Br)	CU NIPDAU	Level-3-260C-168 HR	-40 to 85	AZ62P28	<a href="#">Samples</a>
ADS62P28IRGCT	ACTIVE	VQFN	RGC	64	250	Green (RoHS & no Sb/Br)	CU NIPDAU	Level-3-260C-168 HR	-40 to 85	AZ62P28	<a href="#">Samples</a>
ADS62P29IRGCR	ACTIVE	VQFN	RGC	64	2000	Green (RoHS & no Sb/Br)	CU NIPDAU	Level-3-260C-168 HR	-40 to 85	AZ62P29	<a href="#">Samples</a>
ADS62P29IRGCT	ACTIVE	VQFN	RGC	64	250	Green (RoHS & no Sb/Br)	CU NIPDAU	Level-3-260C-168 HR	-40 to 85	AZ62P29	<a href="#">Samples</a>
ADS62P48IRGCR	ACTIVE	VQFN	RGC	64	2000	Green (RoHS & no Sb/Br)	CU NIPDAU	Level-3-260C-168 HR	-40 to 85	AZ62P48	<a href="#">Samples</a>
ADS62P48IRGCT	ACTIVE	VQFN	RGC	64	250	Green (RoHS & no Sb/Br)	CU NIPDAU	Level-3-260C-168 HR	-40 to 85	AZ62P48	<a href="#">Samples</a>
ADS62P49IRGCR	ACTIVE	VQFN	RGC	64	2000	Green (RoHS & no Sb/Br)	CU NIPDAU	Level-3-260C-168 HR	-40 to 85	AZ62P49	<a href="#">Samples</a>
ADS62P49IRGCT	ACTIVE	VQFN	RGC	64	250	Green (RoHS & no Sb/Br)	CU NIPDAU	Level-3-260C-168 HR	-40 to 85	AZ62P49	<a href="#">Samples</a>

(1) The marketing status values are defined as follows:

**ACTIVE:** Product device recommended for new designs.

**LIFEBUY:** TI has announced that the device will be discontinued, and a lifetime-buy period is in effect.

**NRND:** Not recommended for new designs. Device is in production to support existing customers, but TI does not recommend using this part in a new design.

**PREVIEW:** Device has been announced but is not in production. Samples may or may not be available.

**OBSOLETE:** TI has discontinued the production of the device.

(2) Eco Plan - The planned eco-friendly classification: Pb-Free (RoHS), Pb-Free (RoHS Exempt), or Green (RoHS & no Sb/Br) - please check <http://www.ti.com/productcontent> for the latest availability information and additional product content details.

**TBD:** The Pb-Free/Green conversion plan has not been defined.

**Pb-Free (RoHS):** TI's terms "Lead-Free" or "Pb-Free" mean semiconductor products that are compatible with the current RoHS requirements for all 6 substances, including the requirement that lead not exceed 0.1% by weight in homogeneous materials. Where designed to be soldered at high temperatures, TI Pb-Free products are suitable for use in specified lead-free processes.

**Pb-Free (RoHS Exempt):** This component has a RoHS exemption for either 1) lead-based flip-chip solder bumps used between the die and package, or 2) lead-based die adhesive used between the die and leadframe. The component is otherwise considered Pb-Free (RoHS compatible) as defined above.

**Green (RoHS & no Sb/Br):** TI defines "Green" to mean Pb-Free (RoHS compatible), and free of Bromine (Br) and Antimony (Sb) based flame retardants (Br or Sb do not exceed 0.1% by weight in homogeneous material)

(3) MSL, Peak Temp. - The Moisture Sensitivity Level rating according to the JEDEC industry standard classifications, and peak solder temperature.

(4) There may be additional marking, which relates to the logo, the lot trace code information, or the environmental category on the device.

(5) Multiple Device Markings will be inside parentheses. Only one Device Marking contained in parentheses and separated by a "~" will appear on a device. If a line is indented then it is a continuation of the previous line and the two combined represent the entire Device Marking for that device.

(6) Lead/Ball Finish - Orderable Devices may have multiple material finish options. Finish options are separated by a vertical ruled line. Lead/Ball Finish values may wrap to two lines if the finish value exceeds the maximum column width.

**Important Information and Disclaimer:**The information provided on this page represents TI's knowledge and belief as of the date that it is provided. TI bases its knowledge and belief on information provided by third parties, and makes no representation or warranty as to the accuracy of such information. Efforts are underway to better integrate information from third parties. TI has taken and continues to take reasonable steps to provide representative and accurate information but may not have conducted destructive testing or chemical analysis on incoming materials and chemicals. TI and TI suppliers consider certain information to be proprietary, and thus CAS numbers and other limited information may not be available for release.

In no event shall TI's liability arising out of such information exceed the total purchase price of the TI part(s) at issue in this document sold by TI to Customer on an annual basis.

## TAPE AND REEL INFORMATION

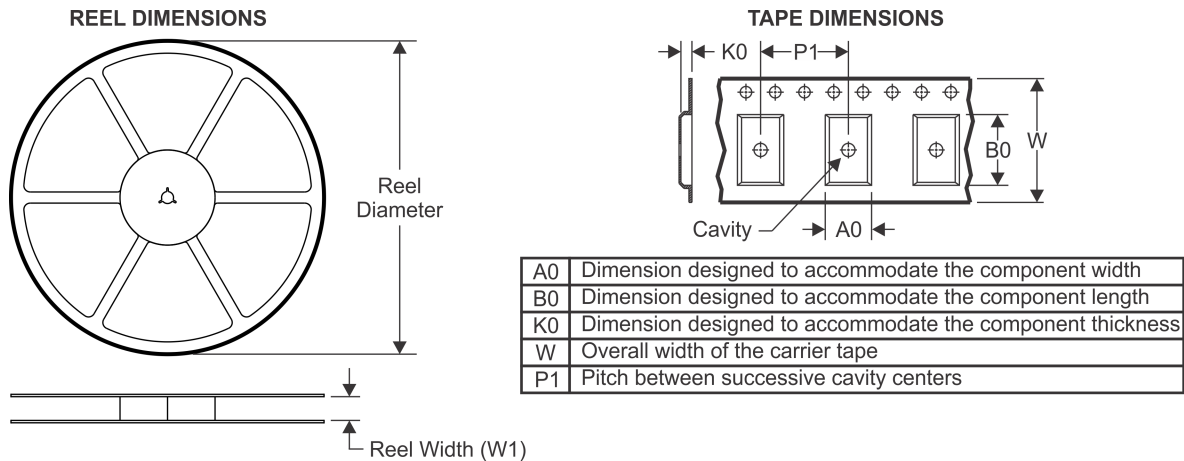

### QUADRANT ASSIGNMENTS FOR PIN 1 ORIENTATION IN TAPE

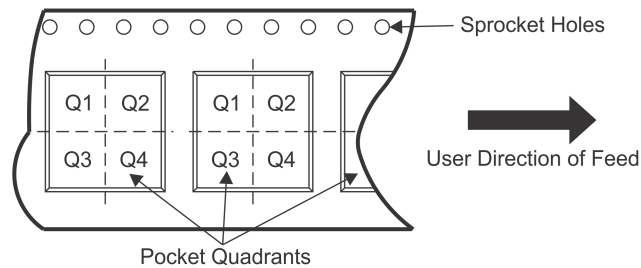

\*All dimensions are nominal

Device	Package Type	Package Drawing	Pins	SPQ	Reel Diameter (mm)	Reel Width W1 (mm)	A0 (mm)	B0 (mm)	K0 (mm)	P1 (mm)	W (mm)	Pin1 Quadrant
ADS62P28IRGCR	VQFN	RGC	64	2000	330.0	16.4	9.3	9.3	1.5	12.0	16.0	Q2
ADS62P28IRGCT	VQFN	RGC	64	250	180.0	16.4	9.3	9.3	1.5	12.0	16.0	Q2
ADS62P29IRGCR	VQFN	RGC	64	2000	330.0	16.4	9.3	9.3	1.5	12.0	16.0	Q2
ADS62P29IRGCT	VQFN	RGC	64	250	180.0	16.4	9.3	9.3	1.5	12.0	16.0	Q2
ADS62P48IRGCR	VQFN	RGC	64	2000	330.0	16.4	9.3	9.3	1.5	12.0	16.0	Q2
ADS62P48IRGCT	VQFN	RGC	64	250	180.0	16.4	9.3	9.3	1.5	12.0	16.0	Q2
ADS62P49IRGCR	VQFN	RGC	64	2000	330.0	16.4	9.3	9.3	1.5	12.0	16.0	Q2
ADS62P49IRGCT	VQFN	RGC	64	250	180.0	16.4	9.3	9.3	1.5	12.0	16.0	Q2

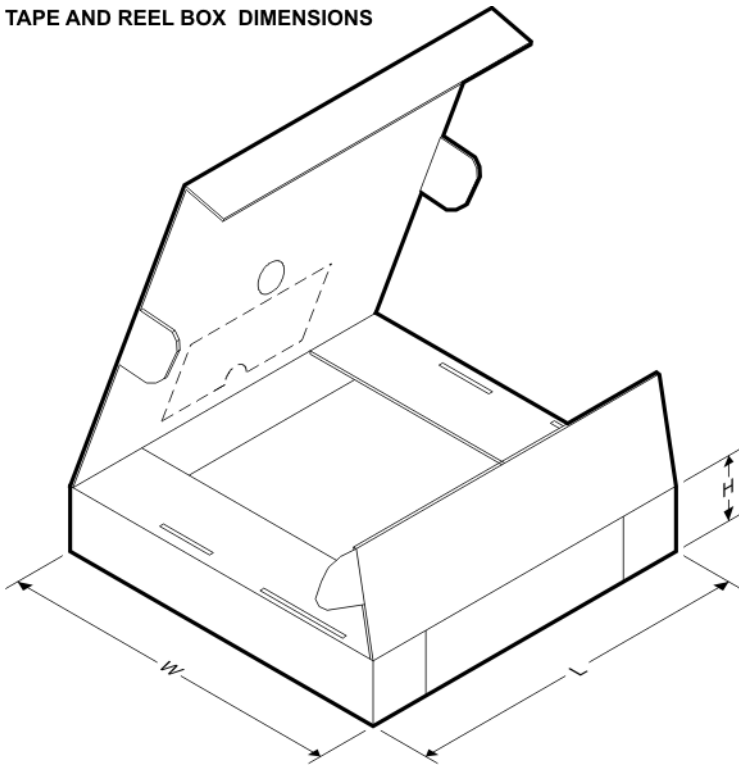
**TAPE AND REEL BOX DIMENSIONS**

\*All dimensions are nominal

Device	Package Type	Package Drawing	Pins	SPQ	Length (mm)	Width (mm)	Height (mm)
ADS62P28IRGCR	VQFN	RGC	64	2000	350.0	350.0	43.0
ADS62P28IRGCT	VQFN	RGC	64	250	213.0	191.0	55.0
ADS62P29IRGCR	VQFN	RGC	64	2000	350.0	350.0	43.0
ADS62P29IRGCT	VQFN	RGC	64	250	213.0	191.0	55.0
ADS62P48IRGCR	VQFN	RGC	64	2000	350.0	350.0	43.0
ADS62P48IRGCT	VQFN	RGC	64	250	213.0	191.0	55.0
ADS62P49IRGCR	VQFN	RGC	64	2000	350.0	350.0	43.0
ADS62P49IRGCT	VQFN	RGC	64	250	213.0	191.0	55.0

## GENERIC PACKAGE VIEW

**RGC 64**

**VQFN - 1 mm max height**

9 x 9, 0.5 mm pitch

PLASTIC QUAD FLATPACK - NO LEAD

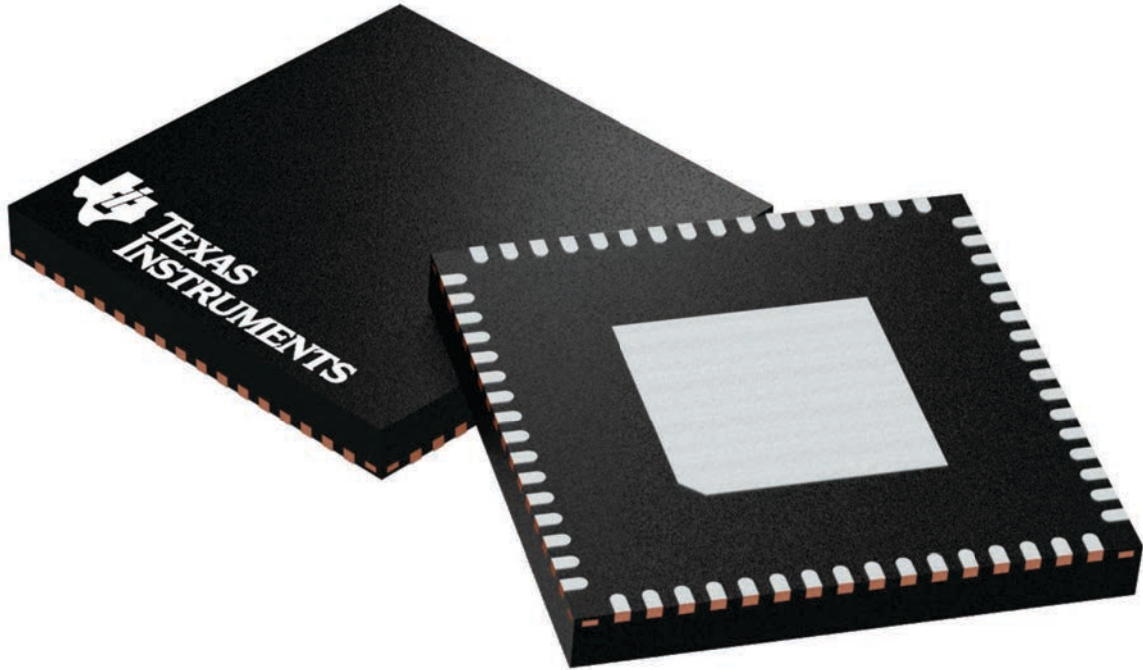

Images above are just a representation of the package family, actual package may vary.  
Refer to the product data sheet for package details.

4224597/A

# RGC0064H

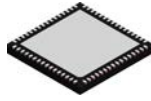

## PACKAGE OUTLINE

VQFN - 1 mm max height

PLASTIC QUAD FLATPACK - NO LEAD

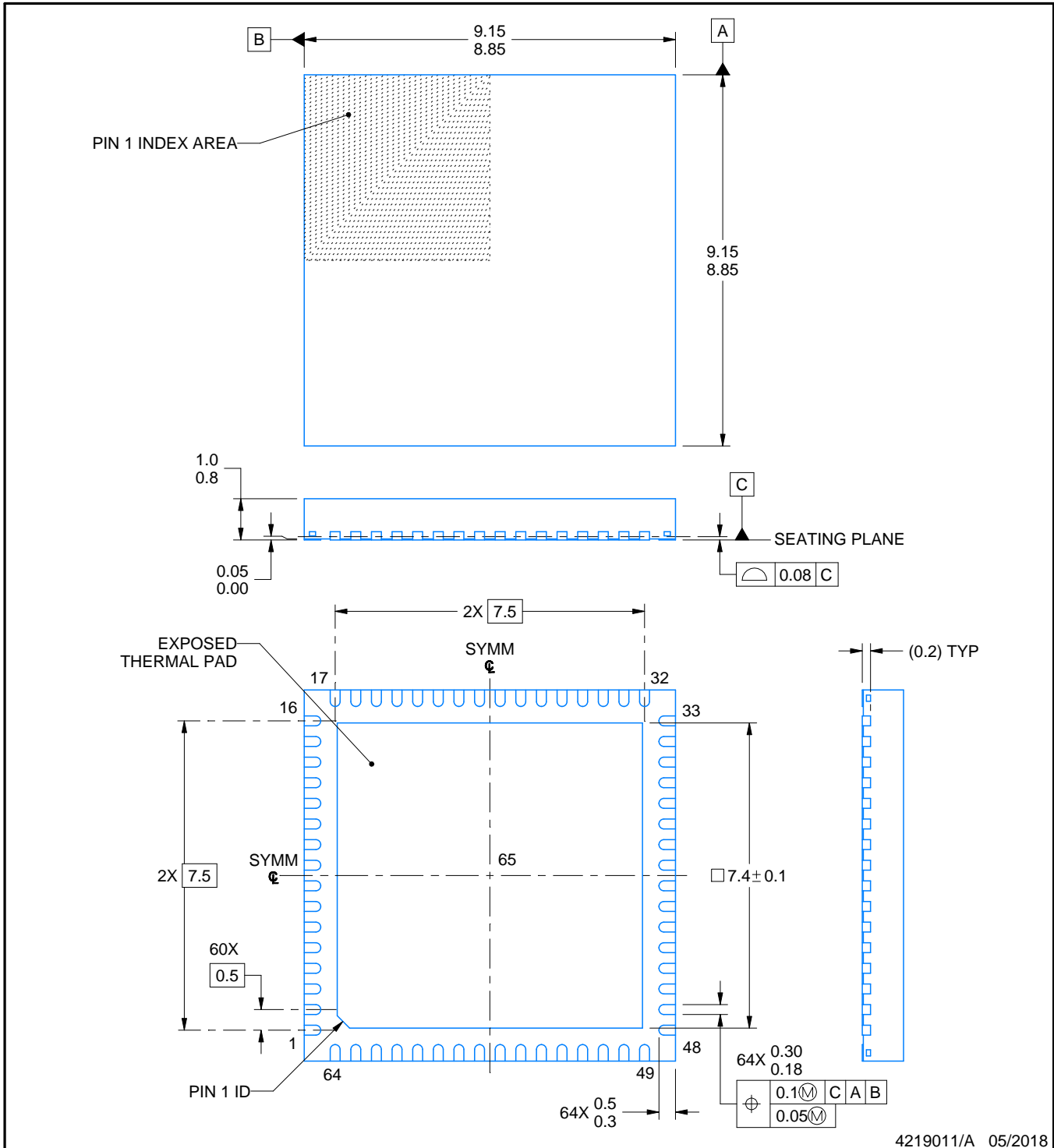

4219011/A 05/2018

**NOTES:**

1. All linear dimensions are in millimeters. Any dimensions in parenthesis are for reference only. Dimensioning and tolerancing per ASME Y14.5M.
2. This drawing is subject to change without notice.
3. The package thermal pad must be soldered to the printed circuit board for thermal and mechanical performance.

# EXAMPLE BOARD LAYOUT

RGC0064H

VQFN - 1 mm max height

PLASTIC QUAD FLATPACK - NO LEAD

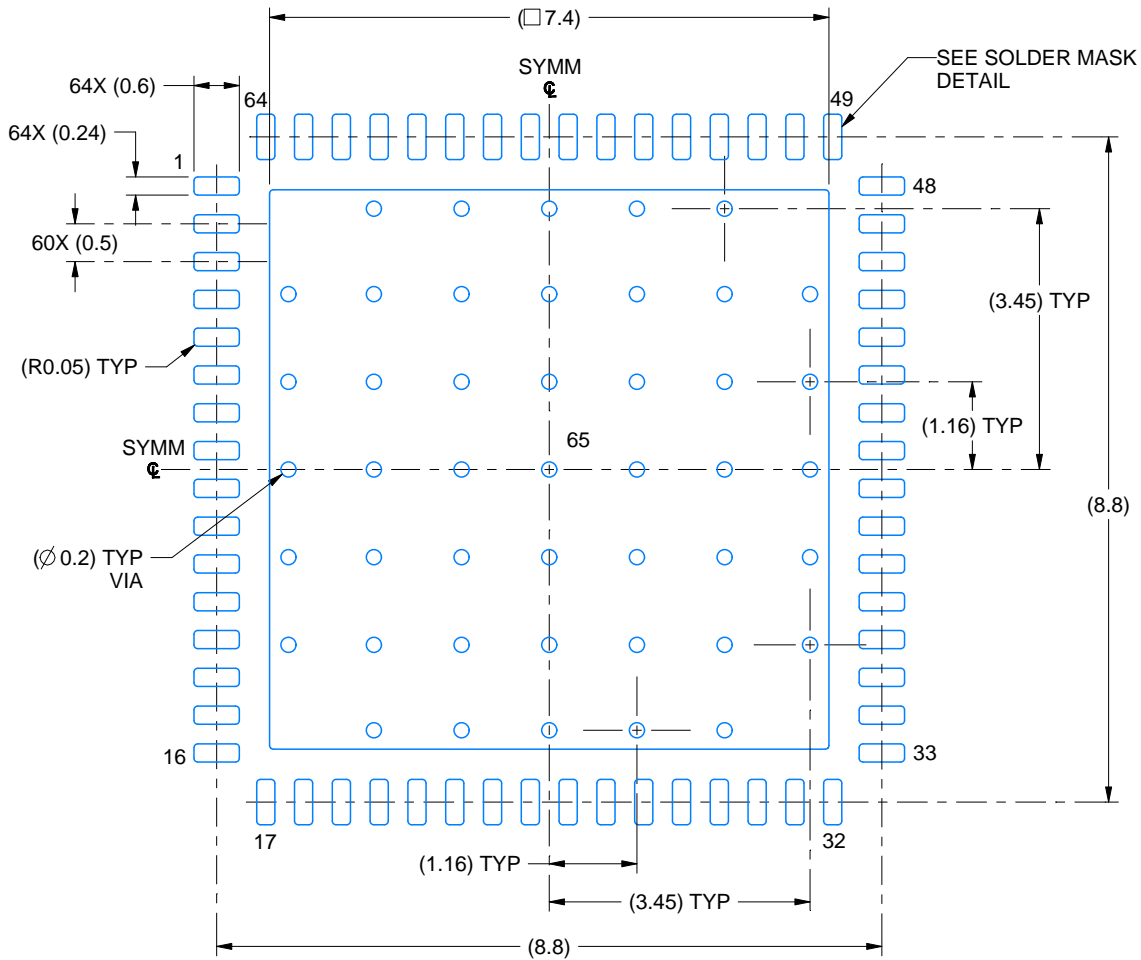

LAND PATTERN EXAMPLE  
EXPOSED METAL SHOWN  
SCALE: 10X

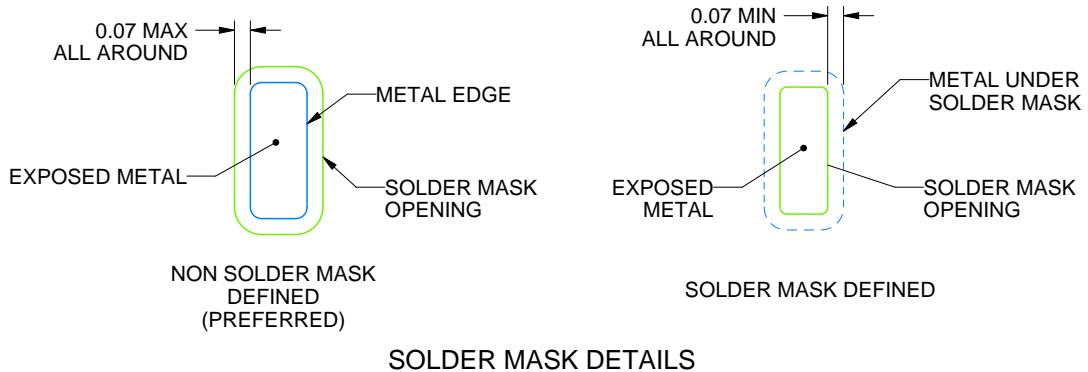

4219011/A 05/2018

NOTES: (continued)

- This package is designed to be soldered to a thermal pad on the board. For more information, see Texas Instruments literature number SLUA271 ([www.ti.com/lit/sluea271](http://www.ti.com/lit/sluea271)).
- Vias are optional depending on application, refer to device data sheet. If any vias are implemented, refer to their locations shown on this view. It is recommended that vias under paste be filled, plugged or tented.

# EXAMPLE STENCIL DESIGN

RGC0064H

VQFN - 1 mm max height

PLASTIC QUAD FLATPACK - NO LEAD

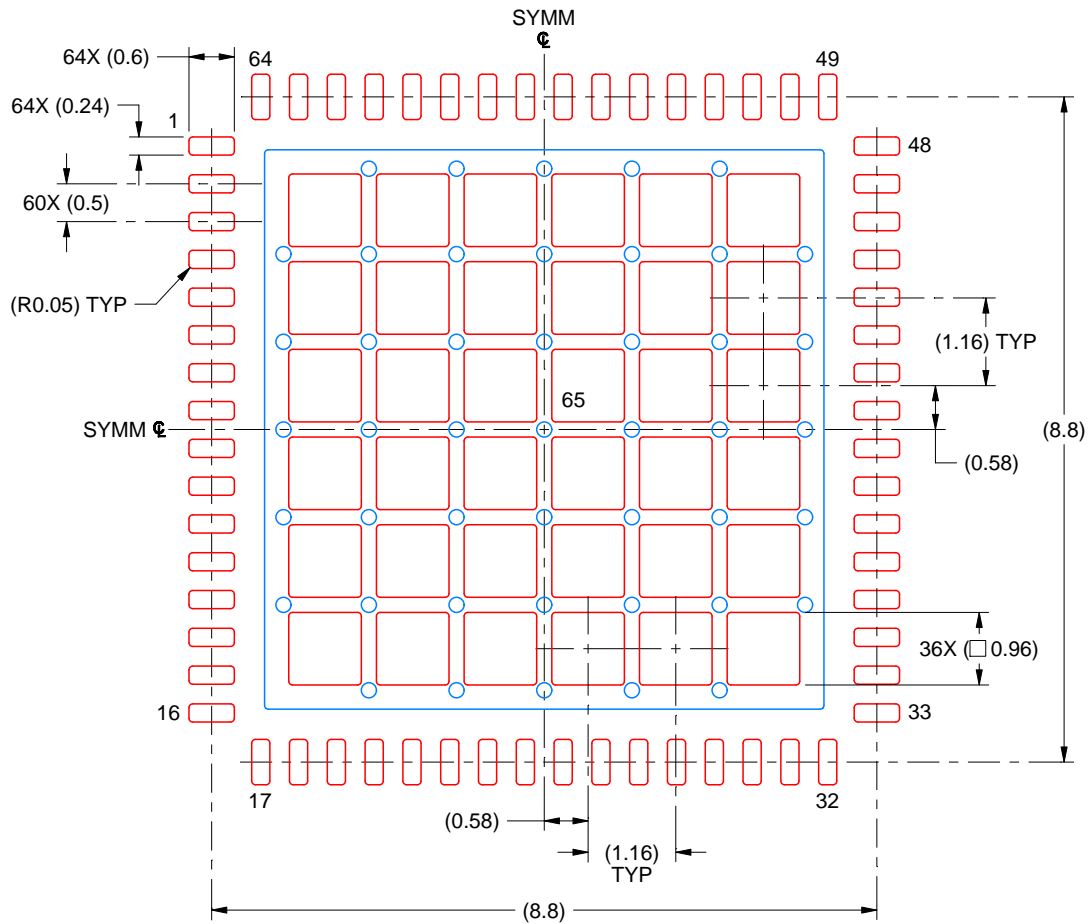

SOLDER PASTE EXAMPLE  
 BASED ON 0.125 MM THICK STENCIL  
 SCALE: 10X

EXPOSED PAD 65  
 61% PRINTED SOLDER COVERAGE BY AREA UNDER PACKAGE

4219011/A 05/2018

NOTES: (continued)

6. Laser cutting apertures with trapezoidal walls and rounded corners may offer better paste release. IPC-7525 may have alternate design recommendations.

## IMPORTANT NOTICE AND DISCLAIMER

TI PROVIDES TECHNICAL AND RELIABILITY DATA (INCLUDING DATASHEETS), DESIGN RESOURCES (INCLUDING REFERENCE DESIGNS), APPLICATION OR OTHER DESIGN ADVICE, WEB TOOLS, SAFETY INFORMATION, AND OTHER RESOURCES "AS IS" AND WITH ALL FAULTS, AND DISCLAIMS ALL WARRANTIES, EXPRESS AND IMPLIED, INCLUDING WITHOUT LIMITATION ANY IMPLIED WARRANTIES OF MERCHANTABILITY, FITNESS FOR A PARTICULAR PURPOSE OR NON-INFRINGEMENT OF THIRD PARTY INTELLECTUAL PROPERTY RIGHTS.

These resources are intended for skilled developers designing with TI products. You are solely responsible for (1) selecting the appropriate TI products for your application, (2) designing, validating and testing your application, and (3) ensuring your application meets applicable standards, and any other safety, security, or other requirements. These resources are subject to change without notice. TI grants you permission to use these resources only for development of an application that uses the TI products described in the resource. Other reproduction and display of these resources is prohibited. No license is granted to any other TI intellectual property right or to any third party intellectual property right. TI disclaims responsibility for, and you will fully indemnify TI and its representatives against, any claims, damages, costs, losses, and liabilities arising out of your use of these resources.

TI's products are provided subject to TI's Terms of Sale ([www.ti.com/legal/termsofsale.html](http://www.ti.com/legal/termsofsale.html)) or other applicable terms available either on [ti.com](http://ti.com) or provided in conjunction with such TI products. TI's provision of these resources does not expand or otherwise alter TI's applicable warranties or warranty disclaimers for TI products.

Mailing Address: Texas Instruments, Post Office Box 655303, Dallas, Texas 75265  
Copyright © 2019, Texas Instruments Incorporated

## Looking for pricing, stock, or lifecycle information?

Click below to explore more details on WIN SOURCE:

⊖ [View ADS62P49IRGCT](#) on WIN SOURCE

⊖ [Texas Instruments](#) Information

## Optimize Your Supply Chain with WIN SOURCE Solutions

- ✓ Global Sourcing Solution
- ✓ Obsolete Management
- ✓ Cost Control Management
- ✓ Shortage Management
- ✓ Alternative Solution
- ✓ Excess Inventory Management