



**THE DATASHEET OF
LM3429Q1MHX/NOPB**



LM3429/-Q1 N-Channel Controller for Constant Current LED Drivers

1 Features

- LM3429-Q1 is AEC-Q100 Grade 1 Qualified for Automotive Applications
- V_{IN} Range From 4.5 V to 75 V
- Adjustable Current Sense Voltage
- High-Side Current Sensing
- 2- Ω , 1-A Peak MosFET Gate Driver
- Input Undervoltage Protection
- Overvoltage Protection
- PWM Dimming
- Analog Dimming
- Cycle-by-Cycle Current Limit
- Programmable Switching Frequency
- Low Profile 14-lead HTSSOP Package
- Thermal Shutdown

2 Applications

- LED Drivers - Buck, Boost, Buck-Boost, SEPIC
- Indoor and Outdoor SSL
- Automotive
- General Illumination
- Constant-Current Regulators

3 Description

The LM3429 is a versatile high voltage N-channel MosFET controller for LED drivers. It can be easily configured in buck, boost, buck-boost and SEPIC topologies. This flexibility, along with an input voltage rating of 75V, makes the LM3429 ideal for illuminating LEDs in a very diverse, large family of applications.

Adjustable high-side current sense voltage allows for tight regulation of the LED current with the highest efficiency possible. The LM3429 uses Predictive Off-time (PRO) control, which is a combination of peak current-mode control and a predictive off-timer. This method of control eases the design of loop compensation while providing inherent input voltage feed-forward compensation.

The LM3429 includes a high-voltage startup regulator that operates over a wide input range of 4.5 V to 75 V. The internal PWM controller is designed for adjustable switching frequencies of up to 2 MHz, thus enabling compact solutions. Additional features include analog dimming, PWM dimming, overvoltage protection, undervoltage lock-out, cycle-by-cycle current limit, and thermal shutdown.

Device Information⁽¹⁾

PART NUMBER	PACKAGE	BODY SIZE (NOM)
LM3429	HTSSOP (14)	5.00 mm x 4.40 mm
LM3429-Q1		

(1) For all available packages, see the orderable addendum at the end of the data sheet.

Typical Boost Application Circuit

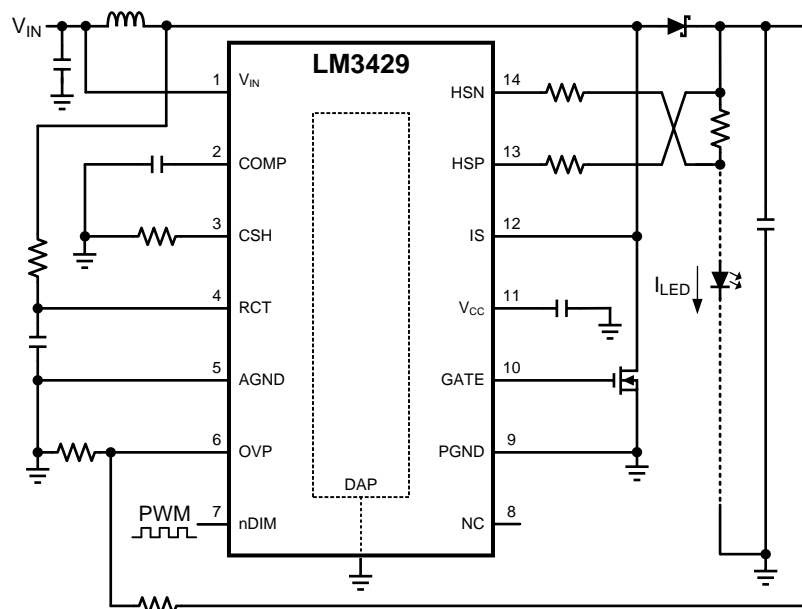

Table of Contents

1 Features	1	8 Application and Implementation	22
2 Applications	1	8.1 Application Information.....	22
3 Description	1	8.2 Typical Applications	24
4 Revision History	2	9 Power Supply Recommendations	53
5 Pin Configuration and Functions	3	9.1 Input Supply Current Limit	53
6 Specifications	4	10 Layout	53
6.1 Absolute Maximum Ratings	4	10.1 Layout Guidelines	53
6.2 ESD Ratings.....	4	10.2 Layout Example	54
6.3 Recommended Operating Conditions.....	4	11 Device and Documentation Support	55
6.4 Thermal Information	5	11.1 Device Support.....	55
6.5 Electrical Characteristics	5	11.2 Documentation Support	55
6.6 Typical Characteristics	7	11.3 Related Links	55
7 Detailed Description	9	11.4 Community Resources.....	55
7.1 Overview	9	11.5 Trademarks	55
7.2 Functional Block Diagram	9	11.6 Electrostatic Discharge Caution.....	56
7.3 Feature Description.....	10	11.7 Glossary	56
7.4 Device Functional Modes.....	21	12 Mechanical, Packaging, and Orderable Information	56

4 Revision History

NOTE: Page numbers for previous revisions may differ from page numbers in the current version.

Changes from Revision G (April 2013) to Revision H	Page
<ul style="list-style-type: none"> Added <i>Pin Configuration and Functions</i> section, <i>Handling Rating</i> table, <i>Feature Description</i> section, <i>Device Functional Modes</i>, <i>Application and Implementation</i> section, <i>Power Supply Recommendations</i> section, <i>Layout</i> section, <i>Device and Documentation Support</i> section, and <i>Mechanical, Packaging, and Orderable Information</i> section 	1

Changes from Revision F (May 2013) to Revision G	Page
<ul style="list-style-type: none"> Changed layout of National Data Sheet to TI format 	51
<ul style="list-style-type: none"> Changed layout of National Data Sheet to TI format 	52

5 Pin Configuration and Functions

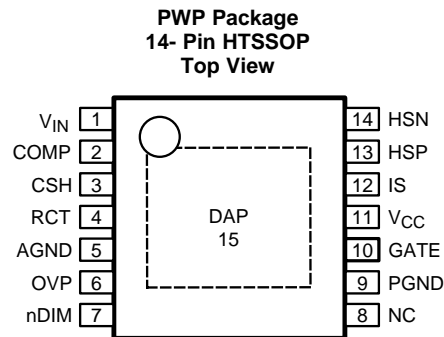

Pin Functions

PIN		I/O	DESCRIPTION	APPLICATION INFORMATION
NO.	NAME			
1	V _{IN}	I	Input Voltage	Bypass with 100 nF capacitor to AGND as close to the device as possible in the circuit board layout.
2	COMP	I	Compensation	Connect a capacitor to AGND to set compensation.
3	CSH	I	Current Sense High	Connect a resistor to AGND to set signal current. For analog dimming, connect current source or potentiometer to AGND (see Analog Dimming section).
4	RCT	I	Resistor Capacitor Timing	Connect a resistor from the switch node and a capacitor to AGND to set the switching frequency.
5	AGND	GND	Analog Ground	Connect to PGND through the DAP copper circuit board pad to provide proper ground return for CSH, COMP, and RCT.
6	OVP	I	Overvoltage Protection	Connect to a resistor divider from the output (V _O) or the input to program output overvoltage lockout (OVLO). Turn-off threshold is 1.24 V and hysteresis for turn-on is provided by 20 μA current source.
7	nDIM	I	Not DIM input	Connect a PWM signal for dimming as detailed in the PWM Dimming section and/or a resistor divider from V _{IN} to program input undervoltage lockout (UVLO). Turn-on threshold is 1.24 V and hysteresis for turn-off is provided by 20 μA current source.
8	NC		No Connection	Leave open.
9	PGND	GND	Power Ground	Connect to AGND through DAP copper pad to provide ground return for GATE.
10	GATE	O	Gate Drive Output	Connect to the gate of the external NFET.
11	V _{CC}	I	Internal Regulator Output	Bypass with a 2.2 μF–3.3 μF, ceramic capacitor to PGND.
12	IS	I	Main Switch Current Sense	Connect to the drain of the main N-channel MosFET switch for R _{DS-ON} sensing or to a sense resistor installed in the source of the same device.
13	HSP	I	LED Current Sense Positive	Connect through a series resistor to LED current sense resistor (positive).
14	HSN	I	LED Current Sense Negative	Connect through a series resistor to LED current sense resistor (negative).
DAP (15)	DAP	GND	Thermal pad on bottom of IC	Connect to AGND and PGND.

6 Specifications

6.1 Absolute Maximum Ratings

 over operating free-air temperature range (unless otherwise noted)⁽¹⁾⁽²⁾

		MIN	MAX	UNIT	
Voltage	V _{IN} , nDIM	-0.3	76	V	
	OVP, HSP, HSN	-0.3	76		
	RCT	-0.3	3		
	IS		-0.3		76
					-2 for 100 ns
	V _{CC}	-0.3	8		
	COMP, CSH	-0.3	6		
	GATE		-0.3		V _{CC}
		-2.5 for 100 ns	V _{CC} +2.5 for 100 ns		
Continuous Current	V _{IN} , nDIM		-1	mA	
				-100	μA
	RCT	-1	5	mA	
	IS		-1	mA	
	COMP, CSH	-200	200	μA	
	GATE	-1	1	mA	
Maximum Junction Temperature		Internally Limited			
Maximum Lead Temperature (Reflow and Solder) ⁽³⁾		260		°C	
Continuous Power Dissipation		Internally Limited			
Storage Temperature, T _{stg}		-65	150	°C	

- (1) Stresses beyond those listed under *Absolute Maximum Ratings* may cause permanent damage to the device. These are stress ratings only, which do not imply functional operation of the device at these or any other conditions beyond those indicated under *Recommended Operating Conditions*. Exposure to absolute-maximum-rated conditions for extended periods may affect device reliability.
- (2) If Military/Aerospace specified devices are required, contact the Texas Instruments Sales Office/Distributors for availability and specifications.
- (3) Refer to <http://www.ti.com/packaging> for more detailed information and mounting techniques.

6.2 ESD Ratings

		VALUE	UNIT
LM3429 IN PWP PACKAGE			
V _(ESD) Electrostatic discharge	Human body model (HBM), per ANSI/ESDA/JEDEC JS-001, all pins ⁽¹⁾	±2000	V
	Charged device model (CDM), per JEDEC specification JESD22-C101, all pins ⁽²⁾	±1000	
LM3429-Q1 IN PWP PACKAGE			
V _(ESD) Electrostatic discharge	Human body model (HBM), per AEC Q100-002 ⁽³⁾	±2000	V
	Charged device model (CDM), per AEC Q100-011	±1000	

- (1) JEDEC document JEP155 states that 500-V HBM allows safe manufacturing with a standard ESD control process.
- (2) JEDEC document JEP157 states that 250-V CDM allows safe manufacturing with a standard ESD control process.
- (3) AEC Q100-002 indicates HBM stressing is done in accordance with the ANSI/ESDA/JEDEC JS-001 specification.

6.3 Recommended Operating Conditions

	MIN	MAX	UNIT
Operating Junction Temperature Range	-40	125	°C
Input Voltage V _{IN}	4.5	75	V

6.4 Thermal Information

THERMAL METRIC ⁽¹⁾		LM3429-Q1	LM3429	UNIT
		PWP (HTSSOP)	PWP (HTSSOP)	
		14 PINS	14 PINS	
R _{θJA}	Junction-to-ambient thermal resistance	47.8	47.8	°C/W
R _{θJC(top)}	Junction-to-case (top) thermal resistance	26.5	26.5	°C/W
R _{θJB}	Junction-to-board thermal resistance	22.3	22.3	°C/W
ψ _{JT}	Junction-to-top characterization parameter	0.7	0.7	°C/W
ψ _{JB}	Junction-to-board characterization parameter	22.1	22.1	°C/W
R _{θJC(bot)}	Junction-to-case (bottom) thermal resistance	3.3	3.3	°C/W

(1) For more information about traditional and new thermal metrics, see the *Semiconductor and IC Package Thermal Metrics* application report, [SPRA953](#).

6.5 Electrical Characteristics

MIN and MAX limits apply T_J = (–40°C to 125°C) unless specified otherwise. Unless otherwise stated the following condition applies: V_{IN} = 14 V.

PARAMETER		TEST CONDITIONS	MIN ⁽¹⁾	TYP ⁽²⁾	MAX ⁽¹⁾	UNIT
STARTUP REGULATOR (V_{CC})						
V _{CC-REG}	V _{CC} Regulation	I _{CC} = 0 mA	6.3	6.9	7.35	V
I _{CC-LIM}	V _{CC} Current Limit	V _{CC} = 0V	20	27		mA
I _Q	Quiescent Current	Static		1.6	3	
V _{CC-UVLO}	V _{CC} UVLO Threshold	V _{CC} Increasing		4.17	4.5	V
		V _{CC} Decreasing	3.7	4.08		
V _{CC-HYS}	V _{CC} UVLO Hysteresis			0.1		
OVERVOLTAGE PROTECTION (OVP)						
V _{TH-OVP}	OVP OVLO Threshold	OVP Increasing	1.18	1.24	1.28	V
I _{HYS-OVP}	OVP Hysteresis Source Current	OVP Active (high)	10	20	30	μA
ERROR AMPLIFIER						
V _{CSH}	CSH Reference Voltage	With Respect to AGND	1.21	1.235	1.26	V
	Error Amplifier Input Bias Current	MIN, MAX: T _J = 25°C	–0.6	0	0.6	μA
	COMP Sink / Source Current		10	26	40	
	Transconductance			100		μA/V
	Linear Input Range	⁽³⁾		±125		mV
	Transconductance Bandwidth	–6dB Unloaded Response ⁽³⁾ , MIN: T _J = 25°C	0.5	1		MHz
OFF TIMER (RCT)						
t _{OFF-MIN}	Minimum Off-time	RCT = 1V through 1 kΩ		35	75	ns
R _{RCT}	RCT Reset Pulldown Resistance			36	120	Ω
V _{RCT}	V _{IN} /25 Reference Voltage	V _{IN} = 14V	540	565	585	mV
PWM COMPARATOR						
	COMP to PWM Offset		700	800	900	mV
CURRENT LIMIT (IS)						
V _{LIM}	Current Limit Threshold		215	245	275	mV
	V _{LIM} Delay to Output			35	75	ns
t _{ON-MIN}	Leading Edge Blanking Time		75	250	450	

(1) All limits specified at room temperature (TYP) and at temperature extremes (MIN/MAX). All room temperature limits are 100% production tested. All limits at temperature extremes are specified through correlation using standard Statistical Quality Control (SQC) methods. All limits are used to calculate Average Outgoing Quality Level (AOQL).

(2) Typical numbers are at 25°C and represent the most likely norm.

(3) These electrical parameters are specified by design, and are not verified by test.

Electrical Characteristics (continued)

MIN and MAX limits apply $T_J = (-40^{\circ}\text{C to } 125^{\circ}\text{C})$ unless specified otherwise. Unless otherwise stated the following condition applies: $V_{IN} = 14\text{ V}$.

PARAMETER		TEST CONDITIONS	MIN ⁽¹⁾	TYP ⁽²⁾	MAX ⁽¹⁾	UNIT
HIGH SIDE TRANSCONDUCTANCE AMPLIFIER						
Input Bias Current				10		μA
Transconductance			20	119		mA/V
Input Offset Current			-1.5	0	1.5	μA
Input Offset Voltage			-7	0	7	mV
Transconductance Bandwidth		$I_{\text{CSH}} = 100\ \mu\text{A}^{(3)}$, MIN: $T_J = 25^{\circ}\text{C}$	250	500		kHz
GATE DRIVER (GATE)						
$R_{\text{SRC(GATE)}}$	GATE Sourcing Resistance	GATE = High		2	6	Ω
$R_{\text{SNK(GATE)}}$	GATE Sinking Resistance	GATE = Low		1.3	4.5	
UNDERVOLTAGE LOCKOUT and DIM INPUT (nDIM)						
$V_{\text{TH-nDIM}}$	nDIM / UVLO Threshold		1.18	1.24	1.28	V
$I_{\text{HYS-nDIM}}$	nDIM Hysteresis Current		10	20	30	μA
THERMAL SHUTDOWN						
T_{SD}	Thermal Shutdown Threshold	⁽³⁾		165		$^{\circ}\text{C}$
T_{HYS}	Thermal Shutdown Hysteresis	⁽³⁾		25		

6.6 Typical Characteristics

$T_A = 25^\circ\text{C}$ and $V_{IN} = 14\text{ V}$ unless otherwise specified. The measurements for Figure 1 and Figure 3 were made using the standard boost evaluation board from AN-1986 (SNVA404). The measurements for Figure 2, Figure 4, and Figure 5, Figure 6 were made using the standard buck-boost evaluation board from AN-1985 (SNVA403).

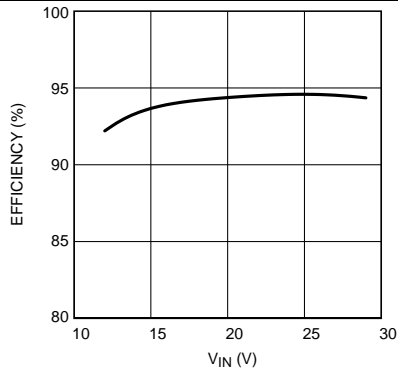

Figure 1. Boost Efficiency vs Input Voltage
 $V_O = 32\text{ V}$ (9 LEDs)

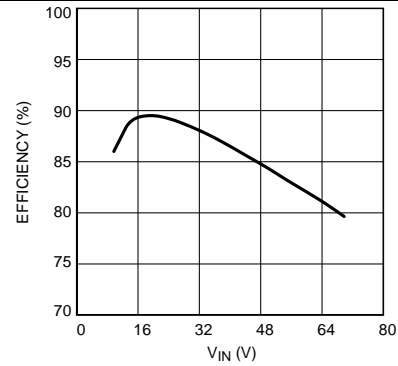

Figure 2. Buck-Boost Efficiency vs Input Voltage
 $V_O = 20\text{ V}$ (6 LEDs)

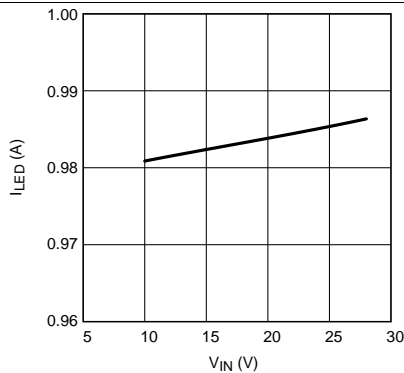

Figure 3. Boost LED Current vs Input Voltage
 $V_O = 32\text{ V}$ (9 LEDs)

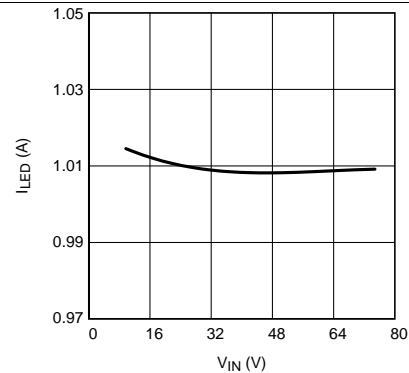

Figure 4. Buck-boost LED Current vs Input Voltage
 $V_O = 20\text{ V}$ (6 LEDs)

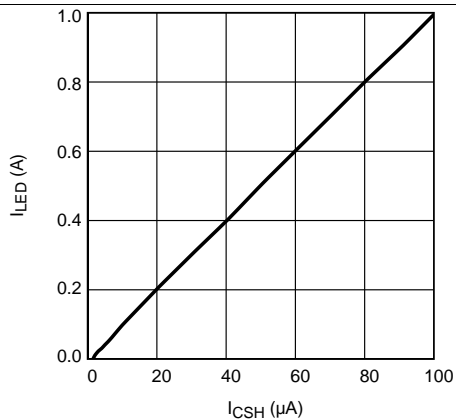

Figure 5. Analog Dimming
 $V_O = 20\text{ V}$ (6 LEDs)

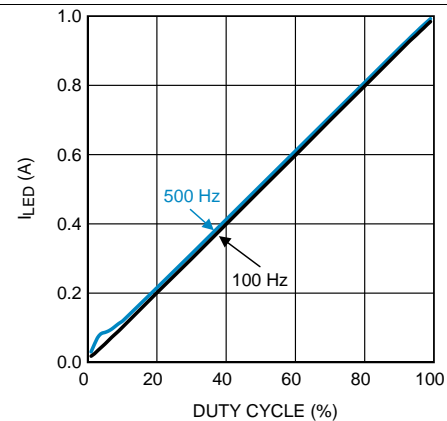

Figure 6. PWM Dimming
 $V_O = 20\text{ V}$ (6 LEDs)

Typical Characteristics (continued)

$T_A = 25^\circ\text{C}$ and $V_{IN} = 14\text{ V}$ unless otherwise specified. The measurements for [Figure 1](#) and [Figure 3](#) were made using the standard boost evaluation board from AN-1986 ([SNVA404](#)). The measurements for [Figure 2](#), [Figure 4](#), and [Figure 5](#), [Figure 6](#) were made using the standard buck-boost evaluation board from AN-1985 ([SNVA403](#)).

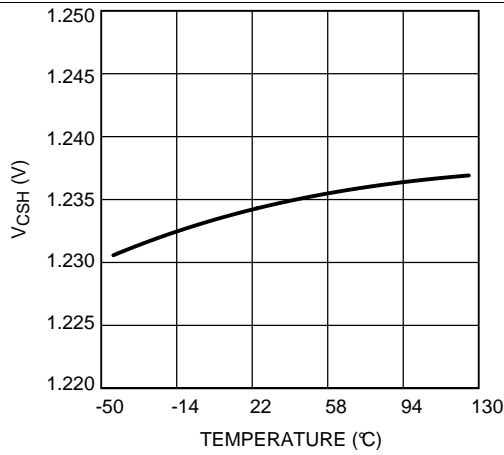

Figure 7. V_{CSH} vs. Junction Temperature

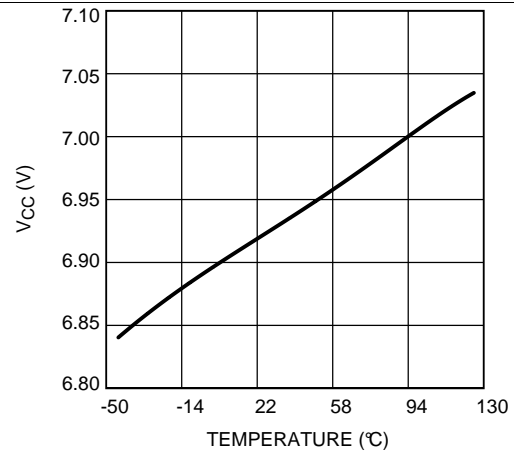

Figure 8. V_{CC} vs. Junction Temperature

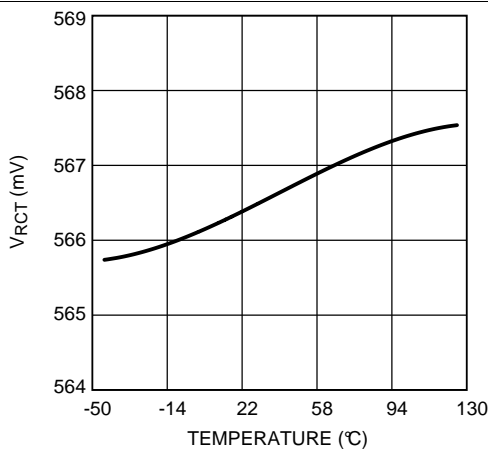

Figure 9. V_{RCT} vs. Junction Temperature

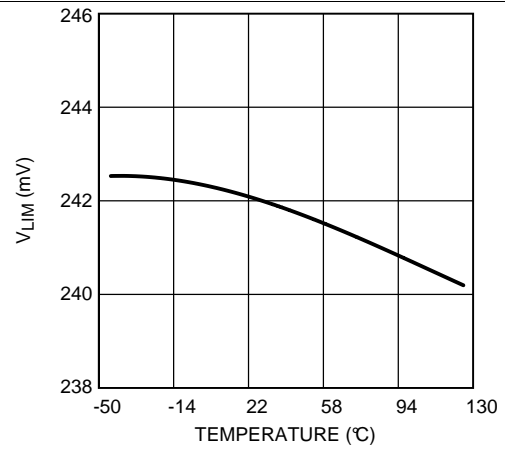

Figure 10. V_{LIM} vs. Junction Temperature

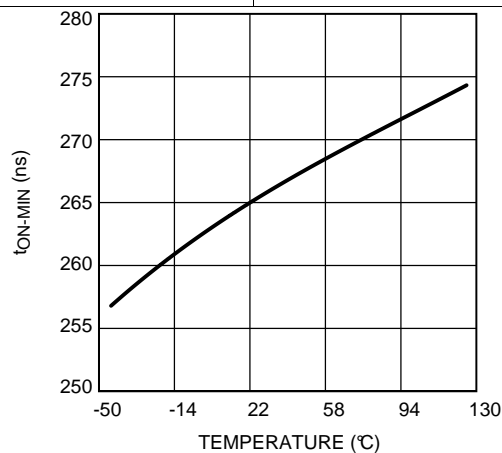

Figure 11. t_{ON-MIN} vs. Junction Temperature

7 Detailed Description

7.1 Overview

The LM3429 is an N-channel MosFET (NFET) controller for buck, boost and buck-boost current regulators which are ideal for driving LED loads. The controller has wide input voltage range allowing for regulation of a variety of LED loads. The high-side differential current sense, with low adjustable threshold voltage, provides an excellent method for regulating output current while maintaining high system efficiency. The LM3429 uses a Predictive Off-time (PRO) control architecture that allows the regulator to be operated using minimal external control loop compensation, while providing an inherent cycle-by-cycle current limit. The adjustable current sense threshold provides the capability to amplitude (analog) dim the LED current and the output enable/disable function allows for PWM dimming using no external components. When designing, the maximum attainable LED current is not internally limited because the LM3429 is a controller. Instead it is a function of the system operating point, component choices, and switching frequency allowing the LM3429 to easily provide constant currents up to 5A. This simple controller contains all the features necessary to implement a high-efficiency versatile LED driver.

7.2 Functional Block Diagram

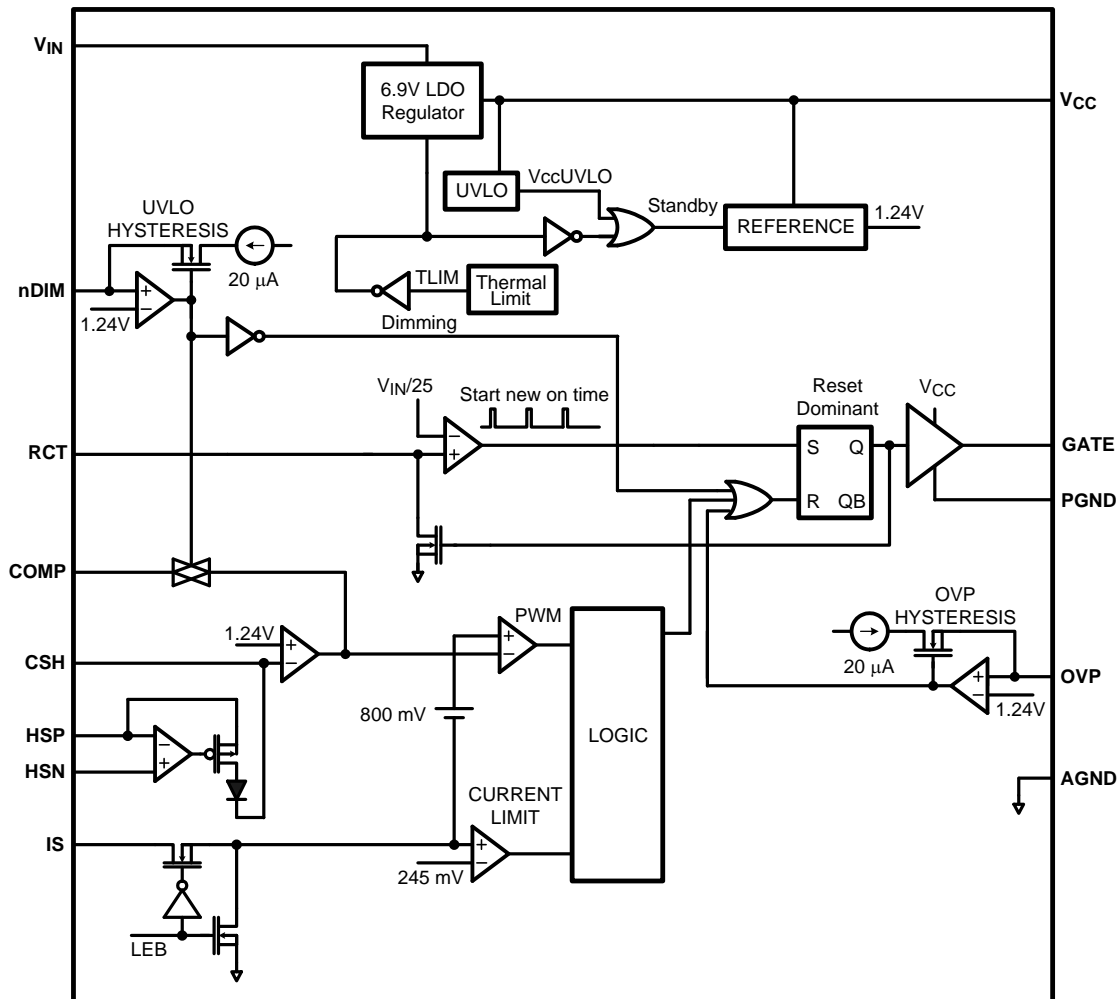

7.3 Feature Description

7.3.1 Current Regulators

Current regulators can be designed to accomplish three basic functions: buck, boost, and buck-boost. All three topologies in their most basic form contain a main switching MosFET, a recirculating diode, an inductor and capacitors. The LM3429 is designed to drive a ground referenced NFET which is perfect for a standard boost regulator. Buck and buck-boost regulators, on the other hand, usually have a high-side switch. When driving an LED load, a ground referenced load is often not necessary, therefore a ground referenced switch can be used to drive a floating load instead. The LM3429 can then be used to drive all three basic topologies as shown in the [Typical Applications](#) section.

Looking at the buck-boost design, the basic operation of a current regulator can be analyzed. During the time that the NFET (Q1) is turned on (t_{ON}), the input voltage source stores energy in the inductor (L1) while the output capacitor (C_O) provides energy to the LED load. When Q1 is turned off (t_{OFF}), the re-circulating diode (D1) becomes forward biased and L1 provides energy to both C_O and the LED load. [Figure 12](#) shows the inductor current ($i_L(t)$) waveform for a regulator operating in CCM.

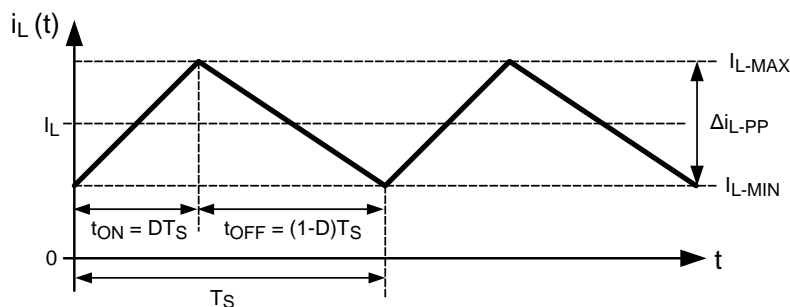

Figure 12. Ideal CCM Regulator Inductor Current $i_L(t)$

The average output LED current (I_{LED}) is proportional to the average inductor current (I_L), therefore if I_L is tightly controlled, I_{LED} will be well regulated. As the system changes input voltage or output voltage, the ideal duty cycle (D) is varied to regulate I_L and ultimately I_{LED} . For any current regulator, D is a function of the conversion ratio:

Buck

$$D = \frac{V_O}{V_{IN}} \quad (1)$$

Boost

$$D = \frac{V_O - V_{IN}}{V_O} \quad (2)$$

Buck-Boost

$$D = \frac{V_O}{V_O + V_{IN}} \quad (3)$$

7.3.2 Predictive Off-Time (PRO) Control

PRO control is used by the LM3429 to control I_{LED} . It is a combination of average peak current control and a one-shot off-timer that varies with input voltage. The LM3429 uses peak current control to regulate the average LED current through an array of HBLEDs. This method of control uses a series resistor in the LED path to sense LED current and can use either a series resistor in the MosFET path or the MosFET R_{DS-ON} for both cycle-by-cycle current limit and input voltage feed forward. D is indirectly controlled by changes in both t_{OFF} and t_{ON} , which vary depending on the operating point.

Feature Description (continued)

Even though the off-time control is quasi-hysteretic, the input voltage proportionality in the off-timer creates an essentially constant switching frequency over the entire operating range for boost and buck-boost topologies. The buck topology can be designed to give constant ripple over either input voltage or output voltage, however switching frequency is only constant at a specific operating point.

This type of control minimizes the control loop compensation necessary in many switching regulators, simplifying the design process. The averaging mechanism in the peak detection control loop provides extremely accurate LED current regulation over the entire operating range.

PRO control was designed to mitigate “current mode instability” (also called “sub-harmonic oscillation”) found in standard peak current mode control when operating near or above 50% duty cycles. When using standard peak current mode control with a fixed switching frequency, this condition is present, regardless of the topology. However, using a constant off-time approach, current mode instability cannot occur, enabling easier design and control.

Predictive off-time advantages:

- There is no current mode instability at any duty cycle.
- Higher duty cycles / voltage transformation ratios are possible, especially in the boost regulator.

The only disadvantage is that synchronization to an external reference frequency is generally not available.

7.3.3 Switching Frequency

An external resistor (R_T) connected between the RCT pin and the switch node (where D1, Q1, and L1 connect), in combination with a capacitor (C_T) between the RCT and AGND pins, sets the off-time (t_{OFF}) as shown in Figure 13. For boost and buck-boost topologies, the V_{IN} proportionality ensures a virtually constant switching frequency (f_{SW}).

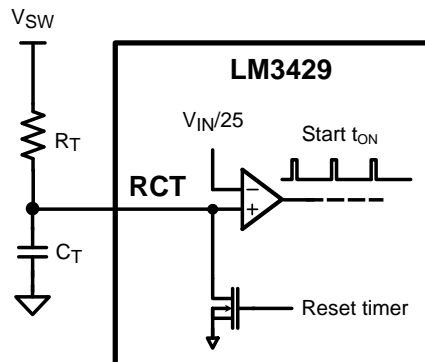
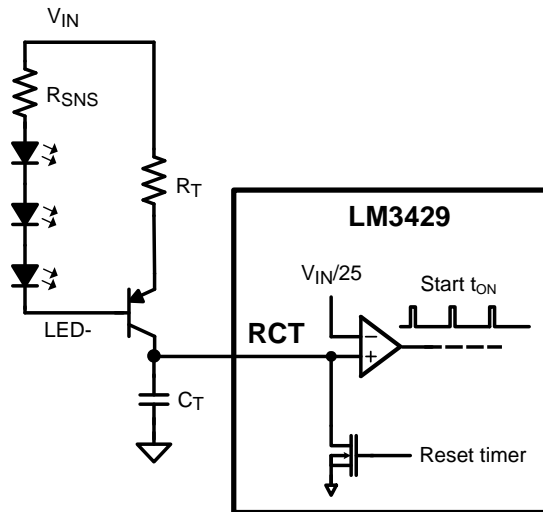

Figure 13. Off-timer Circuitry for Boost and Buck-boost Regulators

For a buck topology, R_T and C_T are also used to set t_{OFF} , however the V_{IN} proportionality will not ensure a constant switching frequency. Instead, constant ripple operation can be achieved. Changing the connection of R_T in Figure 13 from V_{SW} to V_{IN} will provide a constant ripple over varying V_{IN} . Adding a PNP transistor as shown in Figure 14 will provide constant ripple over varying V_O .

Feature Description (continued)

Figure 14. Off-timer Circuitry for Buck Regulators

The switching frequency is defined:

Buck (Constant Ripple vs. V_{IN})

$$f_{SW} = \frac{25 \times (V_{IN} - V_O)}{R_T \times C_T \times V_{IN}} \quad (4)$$

Buck (Constant Ripple vs. V_O)

$$f_{SW} = \frac{25 \times (V_{IN} \times V_O - V_O^2)}{R_T \times C_T \times V_{IN}^2} \quad (5)$$

Boost and Buck-Boost

$$f_{SW} = \frac{25}{R_T \times C_T} \quad (6)$$

For all topologies, the C_T capacitor is recommended to be 1 nF and should be located very close to the LM3429.

7.3.4 Average LED Current

The LM3429 uses an external current sense resistor (R_{SNS}) placed in series with the LED load to convert the LED current (I_{LED}) into a voltage (V_{SNS}) as shown in [Figure 15](#). The HSP and HSN pins are the inputs to the high-side sense amplifier which are forced to be equal potential ($V_{HSP}=V_{HSN}$) through negative feedback. Because of this, the V_{SNS} voltage is forced across R_{HSP} to generate the signal current (I_{CSH}) which flows out of the CSH pin and through the R_{CSH} resistor. The error amplifier will regulate the CSH pin to 1.24 V, therefore I_{CSH} can be calculated:

$$I_{CSH} = \frac{V_{SNS}}{R_{HSP}} \quad (7)$$

This means V_{SNS} will be regulated as follows:

$$V_{SNS} = 1.24V \times \frac{R_{HSP}}{R_{CSH}} \quad (8)$$

I_{LED} can then be calculated:

Feature Description (continued)

$$I_{LED} = \frac{V_{SNS}}{R_{SNS}} = \frac{1.24V}{R_{SNS}} \times \frac{R_{HSP}}{R_{CSH}} \quad (9)$$

The selection of the three resistors (R_{SNS} , R_{CSH} , and R_{HSP}) is not arbitrary. For matching and noise performance, the suggested signal current I_{CSH} is approximately 100 μ A. This current does not flow in the LEDs and will not affect either the off state LED current or the regulated LED current. I_{CSH} can be above or below this value, but the high-side amplifier offset characteristics may be affected slightly. In addition, to minimize the effect of the high-side amplifier voltage offset on LED current accuracy, the minimum V_{SNS} is suggested to be 50 mV. Finally, a resistor ($R_{HSN} = R_{HSP}$) should be placed in series with the HSN pin to cancel out the effects of the input bias current ($\sim 10 \mu$ A) of both inputs of the high-side sense amplifier. The CSH pin can also be used as a low-side current sense input regulated to 1.24 V. The high-side sense amplifier is disabled if HSP and HSN are tied to GND.

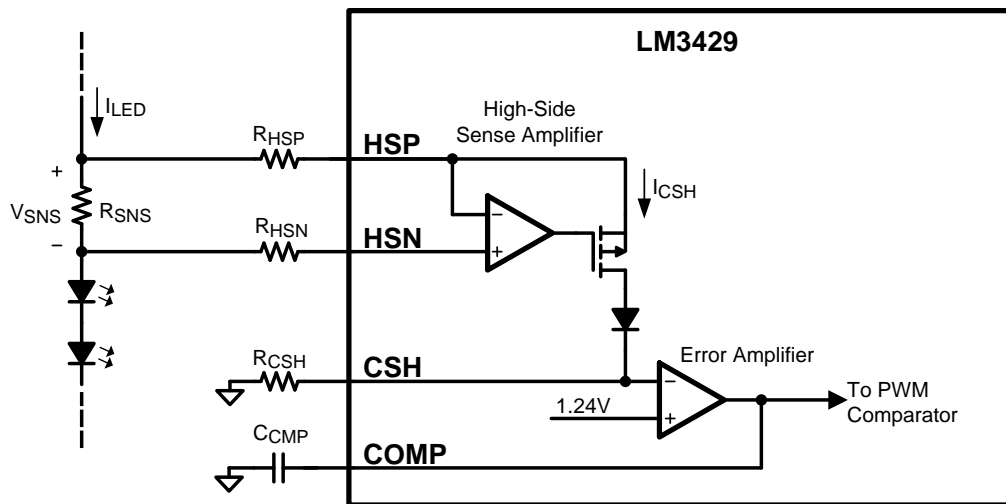

Figure 15. LED Current Sense Circuitry

7.3.5 Analog Dimming

The CSH pin can be used to analog dim the LED current by adjusting the current sense voltage (V_{SNS}). There are several different methods to adjust V_{SNS} using the CSH pin:

1. External variable resistance : Adjust a potentiometer placed in series with R_{CSH} to vary V_{SNS} .
2. External variable current source: Source current (0 μ A to I_{CSH}) into the CSH pin to adjust V_{SNS} .

In general, analog dimming applications require a lower switching frequency to minimize the effect of the leading edge blanking circuit. As the LED current is reduced, the output voltage and the duty cycle decreases. Eventually, the minimum on-time is reached. The lower the switching frequency, the wider the linear dimming range. Figure 16 shows how both methods are physically implemented.

Method 1 uses an external potentiometer in the CSH path which is a simple addition to the existing circuitry. However, the LEDs cannot dim completely because there is always some resistance causing signal current to flow. This method is also susceptible to noise coupling at the CSH pin because the potentiometer increases the size of the signal current loop.

Method 2 provides a complete dimming range and better noise performance, though it is more complex. It consists of a PNP current mirror and a bias network consisting of an NPN, 2 resistors and a potentiometer (R_{ADJ}), where R_{ADJ} controls the amount of current sourced into the CSH pin. A higher resistance value will source more current into the CSH pin causing less regulated signal current through R_{HSP} , effectively dimming the LEDs. V_{REF} should be a precise external voltage reference, while Q7 and Q8 should be a dual pair PNP for best matching and performance. The additional current (I_{ADD}) sourced into the CSH pin can be calculated:

Feature Description (continued)

$$I_{ADD} = \frac{\left(\frac{R_{ADJ} \times V_{REF}}{R_{ADJ} + R_{MAX}} \right) - V_{BE-Q6}}{R_{BIAS}} \quad (10)$$

The corresponding I_{LED} for a specific I_{ADD} is:

$$I_{LED} = (I_{CSH} - I_{ADD}) \times \left(\frac{R_{HSP}}{R_{SNS}} \right) \quad (11)$$

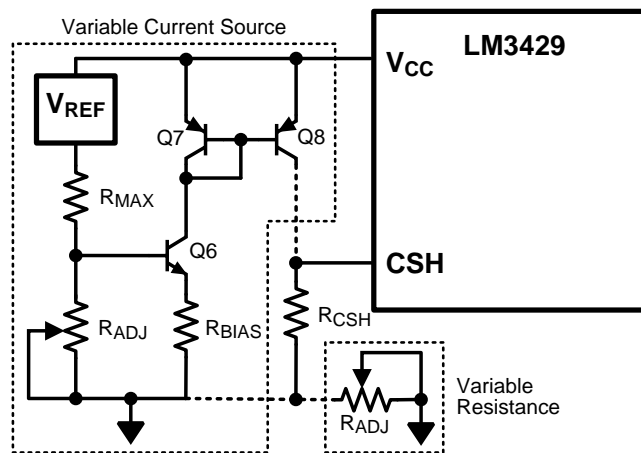

Figure 16. Analog Dimming Circuitry

7.3.6 Current Sense and Current Limit

The LM3429 achieves peak current mode control using a comparator that monitors the MosFET transistor current, comparing it with the COMP pin voltage as shown in [Figure 17](#). Further, it incorporates a cycle-by-cycle overcurrent protection function. Current limit is accomplished by a redundant internal current sense comparator. If the voltage at the current sense comparator input (IS) exceeds 245 mV (typical), the on cycle is immediately terminated. The IS input pin has an internal N-channel MosFET which pulls it down at the conclusion of every cycle. The discharge device remains on an additional 250 ns (typical) after the beginning of a new cycle to blank the leading edge spike on the current sense signal. The leading edge blanking (LEB) determines the minimum achievable on-time (t_{ON-MIN}).

Feature Description (continued)

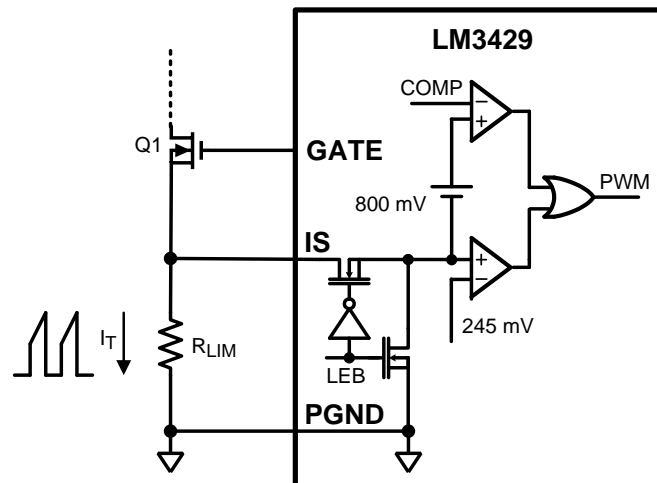

Figure 17. Current Sense / Current Limit Circuitry

There are two possible methods to sense the transistor current. The R_{DS-ON} of the main power MosFET can be used as the current sense resistance because the IS pin was designed to withstand the high voltages present on the drain when the MosFET is in the off state. Alternatively, a sense resistor located in the source of the MosFET may be used for current sensing, however a low inductance (ESL) type is suggested. The cycle-by-cycle current limit (I_{LIM}) can be calculated using either method as the limiting resistance (R_{LIM}):

$$I_{LIM} = \frac{245 \text{ mV}}{R_{LIM}} \quad (12)$$

In general, the external series resistor allows for more design flexibility, however it is important to ensure all of the noise sensitive low power ground connections are connected together local to the controller and a single connection is made to the high current PGND (sense resistor ground point).

7.3.7 Control Loop Compensation

The LM3429 control loop is modeled like any current mode controller. Using a first order approximation, the uncompensated loop can be modeled as a single pole created by the output capacitor and, in the boost and buck-boost topologies, a right half plane zero created by the inductor, where both have a dependence on the LED string dynamic resistance. There is also a high frequency pole in the model, however it is above the switching frequency and plays no part in the compensation design process therefore it will be neglected. Because ceramic capacitance is recommended for use with LED drivers due to long lifetimes and high ripple current rating, the ESR of the output capacitor can also be neglected in the loop analysis. Finally, there is a DC gain of the uncompensated loop which is dependent on internal controller gains and the external sensing network.

A buck-boost regulator will be used as an example case. See the [Typical Applications](#) section for compensation of all topologies.

The uncompensated loop gain for a buck-boost regulator is given by the following equation:

$$T_U = T_{U0} \times \frac{\left(1 - \frac{s}{\omega_{z1}}\right)}{\left(1 + \frac{s}{\omega_{p1}}\right)} \quad (13)$$

Where the uncompensated DC loop gain of the system is described as:

Feature Description (continued)

$$T_{UO} = \frac{D' \times 500V \times R_{CSH} \times R_{SNS}}{(1+D) \times R_{HSP} \times R_{LIM}} = \frac{D' \times 620V}{(1+D) \times I_{LED} \times R_{LIM}} \quad (14)$$

And the output pole (ω_{P1}) is approximated:

$$\omega_{P1} = \frac{1+D}{r_D \times C_O} \quad (15)$$

And the right half plane zero (ω_{Z1}) is:

$$\omega_{Z1} = \frac{r_D \times D'^2}{D \times L1} \quad (16)$$

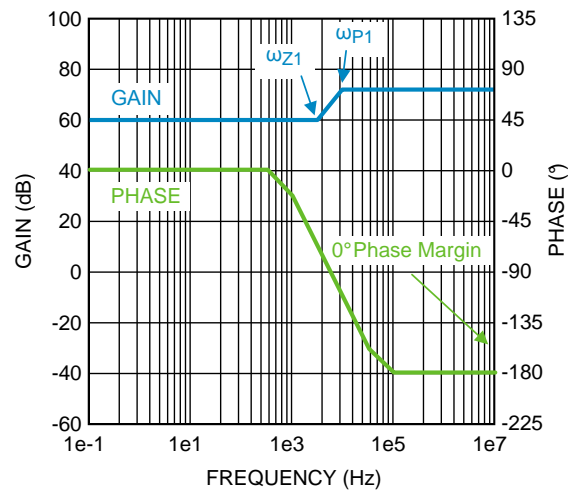

Figure 18. Uncompensated Loop Gain Frequency Response

Figure 18 shows the uncompensated loop gain in a worst-case scenario when the RHP zero is below the output pole. This occurs at high duty cycles when the regulator is trying to boost the output voltage significantly. The RHP zero adds 20dB/decade of gain while loosing 45°/decade of phase which places the crossover frequency (when the gain is zero dB) extremely high because the gain only starts falling again due to the high frequency pole (not modeled or shown in figure). The phase will be below -180° at the crossover frequency which means there is no phase margin (180° + phase at crossover frequency) causing system instability. Even if the output pole is below the RHP zero, the phase will still reach -180° before the crossover frequency in most cases yielding instability.

Feature Description (continued)

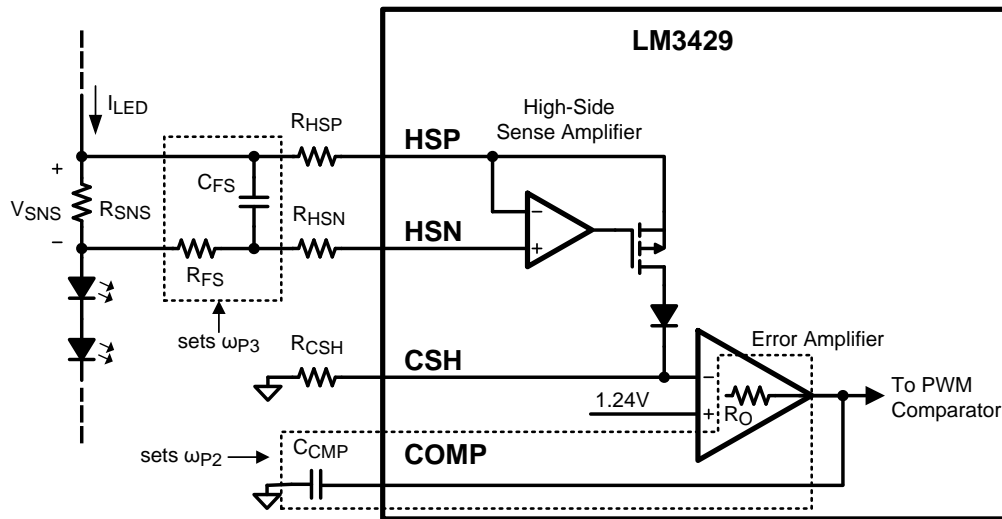

Figure 19. Compensation Circuitry

To mitigate this problem, a compensator should be designed to give adequate phase margin (above 45°) at the crossover frequency. A simple compensator using a single capacitor at the COMP pin (C_{COMP}) will add a dominant pole to the system, which will ensure adequate phase margin if placed low enough. At high duty cycles (as shown in Figure 18), the RHP zero places extreme limits on the achievable bandwidth with this type of compensation. However, because an LED driver is essentially free of output transients (except catastrophic failures open or short), the dominant pole approach, even with reduced bandwidth, is usually the best approach. The dominant compensation pole (ω_{P2}) is determined by C_{COMP} and the output resistance (R_O) of the error amplifier (typically 5 M Ω):

$$\omega_{P2} = \frac{1}{5 \times 10^6 \Omega \times C_{COMP}} \quad (17)$$

It may also be necessary to add one final pole at least one decade above the crossover frequency to attenuate switching noise and, in some cases, provide better gain margin. This pole can be placed across R_{SNS} to filter the ESL of the sense resistor at the same time. Figure 19 shows how the compensation is physically implemented in the system.

The high frequency pole (ω_{P3}) can be calculated:

$$\omega_{P3} = \frac{1}{R_{FS} \times C_{FS}} \quad (18)$$

The total system transfer function becomes:

$$T = T_{U0} \times \frac{\left(1 - \frac{s}{\omega_{Z1}}\right)}{\left(1 + \frac{s}{\omega_{P1}}\right) \times \left(1 + \frac{s}{\omega_{P2}}\right) \times \left(1 + \frac{s}{\omega_{P3}}\right)} \quad (19)$$

The resulting compensated loop gain frequency response shown in Figure 20 indicates that the system has adequate phase margin (above 45°) if the dominant compensation pole is placed low enough, ensuring stability:

Feature Description (continued)

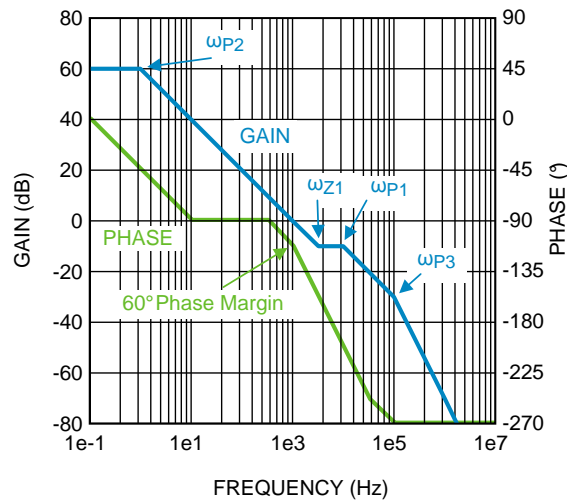

Figure 20. Compensated Loop Gain Frequency Response

7.3.8 Output Overvoltage Lockout (OVLO)

The LM3429 can be configured to detect an output (or input) overvoltage condition through the OVP pin. The pin features a precision 1.24-V threshold with 20 μ A (typical) of hysteresis current as shown in Figure 21. When the OVLO threshold is exceeded, the GATE pin is immediately pulled low and a 20 μ A current source provides hysteresis to the lower threshold of the OVLO hysteretic band.

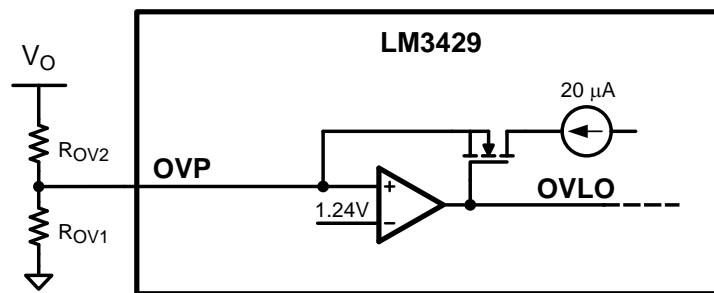

Figure 21. Overvoltage Protection Circuitry

If the LEDs are referenced to a potential other than ground (floating), as in the buck-boost and buck configuration, the output voltage (V_O) should be sensed and translated to ground by using a single PNP as shown in Figure 22.

Feature Description (continued)

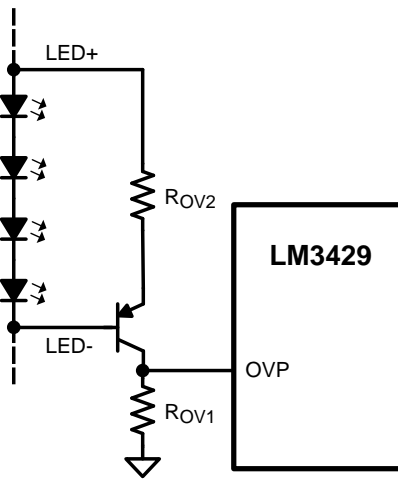

Figure 22. Floating Output OVP Circuitry

The overvoltage turnoff threshold ($V_{\text{TURN-OFF}}$) is defined as follows:

Ground Referenced

$$V_{\text{TURN-OFF}} = 1.24\text{V} \times \left(\frac{R_{\text{OV1}} + R_{\text{OV2}}}{R_{\text{OV1}}} \right) \quad (20)$$

Floating

$$V_{\text{TURN-OFF}} = 1.24\text{V} \times \left(\frac{0.5 \times R_{\text{OV1}} + R_{\text{OV2}}}{R_{\text{OV1}}} \right) \quad (21)$$

In the ground referenced configuration, the voltage across R_{OV2} is $V_{\text{O}} - 1.24\text{V}$ whereas in the floating configuration it is $V_{\text{O}} - 620\text{mV}$ where 620mV approximates the V_{BE} of the PNP transistor.

The overvoltage hysteresis (V_{HYSO}) is defined as follows:

$$V_{\text{HYSO}} = 20\ \mu\text{A} \times R_{\text{OV2}} \quad (22)$$

7.3.9 Input Undervoltage Lockout (UVLO)

The nDIM pin is a dual-function input that features an accurate 1.24V threshold with programmable hysteresis as shown in Figure 23. This pin functions as both the PWM dimming input for the LEDs and as a V_{IN} UVLO. When the pin voltage rises and exceeds the 1.24V threshold, $20\ \mu\text{A}$ (typical) of current is driven out of the nDIM pin into the resistor divider providing programmable hysteresis.

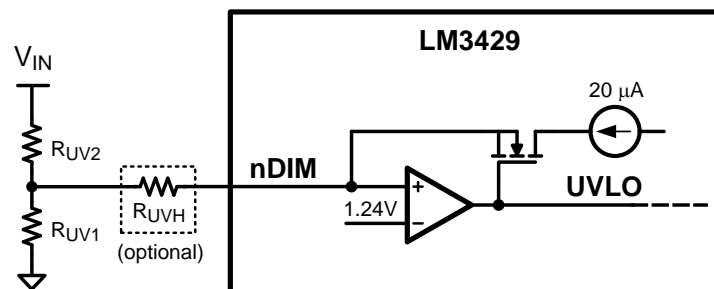

Figure 23. UVLO Circuit

Feature Description (continued)

When using the nDIM pin for UVLO and PWM dimming concurrently, the UVLO circuit can have an extra series resistor to set the hysteresis. This allows the standard resistor divider to have smaller resistor values minimizing PWM delays due to a pulldown MosFET at the nDIM pin (see [PWM Dimming](#) section). In general, at least 3V of hysteresis is necessary when PWM dimming if operating near the UVLO threshold.

The turn-on threshold ($V_{\text{TURN-ON}}$) is defined as follows:

$$V_{\text{TURN ON}} = 1.24\text{V} \times \left(\frac{R_{\text{UV1}} + R_{\text{UV2}}}{R_{\text{UV1}}} \right) \quad (23)$$

The hysteresis (V_{HYS}) is defined as follows:

UVLO Only

$$V_{\text{HYS}} = 20 \mu\text{A} \times R_{\text{UV2}} \quad (24)$$

PWM Dimming and UVLO

$$V_{\text{HYS}} = 20 \mu\text{A} \times \left(R_{\text{UV2}} + \frac{R_{\text{UVH}} \times (R_{\text{UV1}} + R_{\text{UV2}})}{R_{\text{UV1}}} \right) \quad (25)$$

7.3.10 PWM Dimming

The active low nDIM pin can be driven with a PWM signal which controls the main NFET (Q1). The brightness of the LEDs can be varied by modulating the duty cycle of this signal. LED brightness is approximately proportional to the PWM signal duty cycle, so 30% duty cycle equals approximately 30% LED brightness. This function can be ignored if PWM dimming is not required by using nDIM solely as a V_{IN} UVLO input as described in the [Input Undervoltage Lockout \(UVLO\)](#) section or by tying it directly to V_{CC} or V_{IN} (if less than 76VDC).

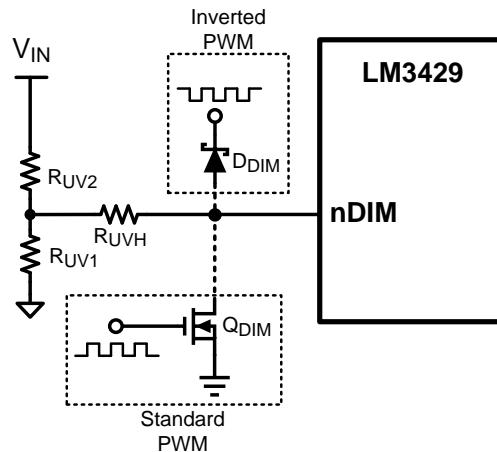

Figure 24. PWM Dimming Circuit

Figure 24 shows two ways the PWM signal can be applied to the nDIM pin:

1. Connect the dimming MosFET (Q_{DIM}) with the drain to the nDIM pin and the source to GND. Apply an external logic-level PWM signal to the gate of Q_{DIM} . A pull down resistor may be necessary to properly turn off Q_{DIM} if no signal is present.
2. Connect the anode of a Schottky diode (D_{DIM}) to the nDIM pin. Apply an external inverted logic-level PWM signal to the cathode of the same diode.

A minimum on-time must be maintained in order for PWM dimming to operate in the linear region of its transfer function. Because the controller is disabled during dimming, the PWM pulse must be long enough such that the energy intercepted from the input is greater than or equal to the energy being put into the LEDs. For boost and buck-boost regulators, the following condition must be maintained:

Feature Description (continued)

$$t_{\text{PULSE}} = \frac{2 \times I_{\text{LED}} \times V_{\text{O}} \times L1}{V_{\text{IN}}^2} \quad (26)$$

In the previous equation, t_{PULSE} is the length of the PWM pulse in seconds.

7.3.11 Startup Regulator (V_{CC} LDO)

The LM3429 includes a high voltage, low dropout (LDO) bias regulator. When power is applied, the regulator is enabled and sources current into an external capacitor connected to the V_{CC} pin. The V_{CC} output voltage is 6.9V nominally and the supply is internally current limited to 20 mA (minimum). The recommended bypass capacitance range for the V_{CC} regulator is 2.2 μF to 3.3 μF . The output of the V_{CC} regulator is monitored by an internal UVLO circuit that protects the device during startup, normal operation, and shutdown from attempting to operate with insufficient supply voltage.

7.3.12 Thermal Shutdown

The LM3429 includes thermal shutdown. If the die temperature reaches approximately 165°C the device will shut down (GATE pin low), until it reaches approximately 140°C where it turns on again.

7.4 Device Functional Modes

This device has no functional modes.

8 Application and Implementation

NOTE

Information in the following applications sections is not part of the TI component specification, and TI does not warrant its accuracy or completeness. TI's customers are responsible for determining suitability of components for their purposes. Customers should validate and test their design implementation to confirm system functionality.

8.1 Application Information

8.1.1 Inductor

The inductor (L1) is the main energy storage device in a switching regulator. Depending on the topology, energy is stored in the inductor and transferred to the load in different ways (as an example, buck-boost operation is detailed in the [Current Regulators](#) section). The size of the inductor, the voltage across it, and the length of the switching subinterval (t_{ON} or t_{OFF}) determines the inductor current ripple (Δi_{L-PP}). In the design process, L1 is chosen to provide a desired Δi_{L-PP} . For a buck regulator the inductor has a direct connection to the load, which is good for a current regulator. This requires little to no output capacitance therefore Δi_{L-PP} is basically equal to the LED ripple current Δi_{LED-PP} . However, for boost and buck-boost regulators, there is always an output capacitor which reduces Δi_{LED-PP} , therefore the inductor ripple can be larger than in the buck regulator case where output capacitance is minimal or completely absent.

In general, Δi_{LED-PP} is recommended by manufacturers to be less than 40% of the average LED current (I_{LED}). Therefore, for the buck regulator with no output capacitance, Δi_{L-PP} should also be less than 40% of I_{LED} . For the boost and buck-boost topologies, Δi_{L-PP} can be much higher depending on the output capacitance value. However, Δi_{L-PP} is suggested to be less than 100% of the average inductor current (I_L) to limit the RMS inductor current.

L1 is also suggested to have an RMS current rating at least 25% higher than the calculated minimum allowable RMS inductor current (I_{L-RMS}).

8.1.2 LED Dynamic Resistance (r_D)

When the load is a string of LEDs, the output load resistance is the LED string dynamic resistance plus R_{SNS} . LEDs are PN junction diodes, and their dynamic resistance shifts as their forward current changes. Dividing the forward voltage of a single LED (V_{LED}) by the forward current (I_{LED}) leads to an incorrect calculation of the dynamic resistance of a single LED (r_{LED}). The result can be 5 to 10 times higher than the true r_{LED} value.

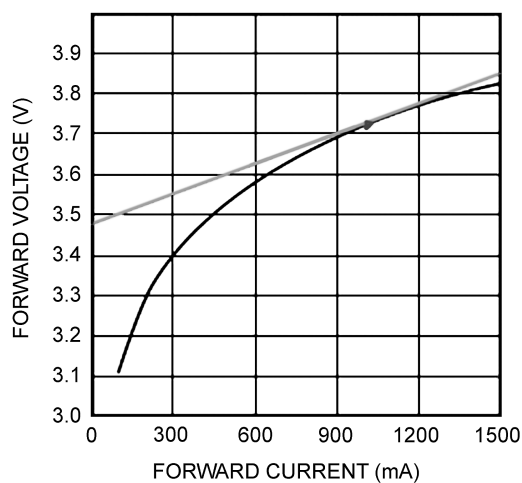

Figure 25. Dynamic Resistance

Obtaining r_{LED} is accomplished by referring to the manufacturer's LED I-V characteristic. It can be calculated as the slope at the nominal operating point as shown in [Figure 25](#). For any application with more than 2 series LEDs, R_{SNS} can be neglected allowing r_D to be approximated as the number of LEDs multiplied by r_{LED} .

Application Information (continued)

8.1.3 Output Capacitor

For boost and buck-boost regulators, the output capacitor (C_O) provides energy to the load when the recirculating diode (D1) is reverse biased during the first switching subinterval. An output capacitor in a buck topology will simply reduce the LED current ripple (Δi_{LED-PP}) below the inductor current ripple (Δi_{L-PP}). In all cases, C_O is sized to provide a desired Δi_{LED-PP} . As mentioned in the [Inductor](#) section, Δi_{LED-PP} is recommended by manufacturers to be less than 40% of the average LED current (I_{LED}).

C_O should be carefully chosen to account for derating due to temperature and operating voltage. It must also have the necessary RMS current rating. Ceramic capacitors are the best choice due to their high ripple current rating, long lifetime, and good temperature performance. An X7R dielectric rating is suggested.

8.1.4 Input Capacitors

The input capacitance (C_{IN}) provides energy during the discontinuous portions of the switching period. For buck and buck-boost regulators, C_{IN} provides energy during t_{ON} and during t_{OFF} , the input voltage source charges up C_{IN} with the average input current (I_{IN}). For boost regulators, C_{IN} only needs to provide the ripple current due to the direct connection to the inductor. C_{IN} is selected given the maximum input voltage ripple (Δv_{IN-PP}) which can be tolerated. Δv_{IN-PP} is suggested to be less than 10% of the input voltage (V_{IN}).

An input capacitance at least 100% greater than the calculated C_{IN} value is recommended to account for derating due to temperature and operating voltage. When PWM dimming, even more capacitance can be helpful to minimize the large current draw from the input voltage source during the rising transition of the LED current waveform.

The chosen input capacitors must also have the necessary RMS current rating. Ceramic capacitors are again the best choice due to their high ripple current rating, long lifetime, and good temperature performance. An X7R dielectric rating is suggested.

For most applications, TI recommends bypassing the V_{IN} pin with an 0.1- μ F ceramic capacitor placed as close as possible to the pin. In situations where the bulk input capacitance may be far from the LM3429 device, a 10- Ω series resistor can be placed between the bulk input capacitance and the bypass capacitor, creating a 150 kHz filter to eliminate undesired high frequency noise coupling.

8.1.5 N-Channel MosFET (NFET)

The LM3429 requires an external NFET (Q1) as the main power MosFET for the switching regulator. Q1 is recommended to have a voltage rating at least 15% higher than the maximum transistor voltage to ensure safe operation during the ringing of the switch node. In practice, all switching regulators have some ringing at the switch node due to the diode parasitic capacitance and the lead inductance. The current rating is recommended to be at least 10% higher than the average transistor current. The power rating is then verified by calculating the power loss given the RMS transistor current and the NFET on-resistance (R_{DS-ON}).

In general, the NFET should be chosen to minimize total gate charge (Q_g) whenever switching frequencies are high and minimize R_{DS-ON} otherwise. This will minimize the dominant power losses in the system. Frequently, higher current NFETs in larger packages are chosen for better thermal performance.

8.1.6 Re-Circulating Diode

A re-circulating diode (D1) is required to carry the inductor current during t_{OFF} . The most efficient choice for D1 is a Schottky diode due to low forward voltage drop and near-zero reverse recovery time. Similar to Q1, D1 is recommended to have a voltage rating at least 15% higher than the maximum transistor voltage to ensure safe operation during the ringing of the switch node and a current rating at least 10% higher than the average diode current. The power rating is verified by calculating the power loss through the diode. This is accomplished by checking the typical diode forward voltage from the I-V curve on the product data sheet and multiplying by the average diode current. In general, higher current diodes have a lower forward voltage and come in better performing packages minimizing both power losses and temperature rise.

8.2 Typical Applications

8.2.1 Basic Topology Schematics

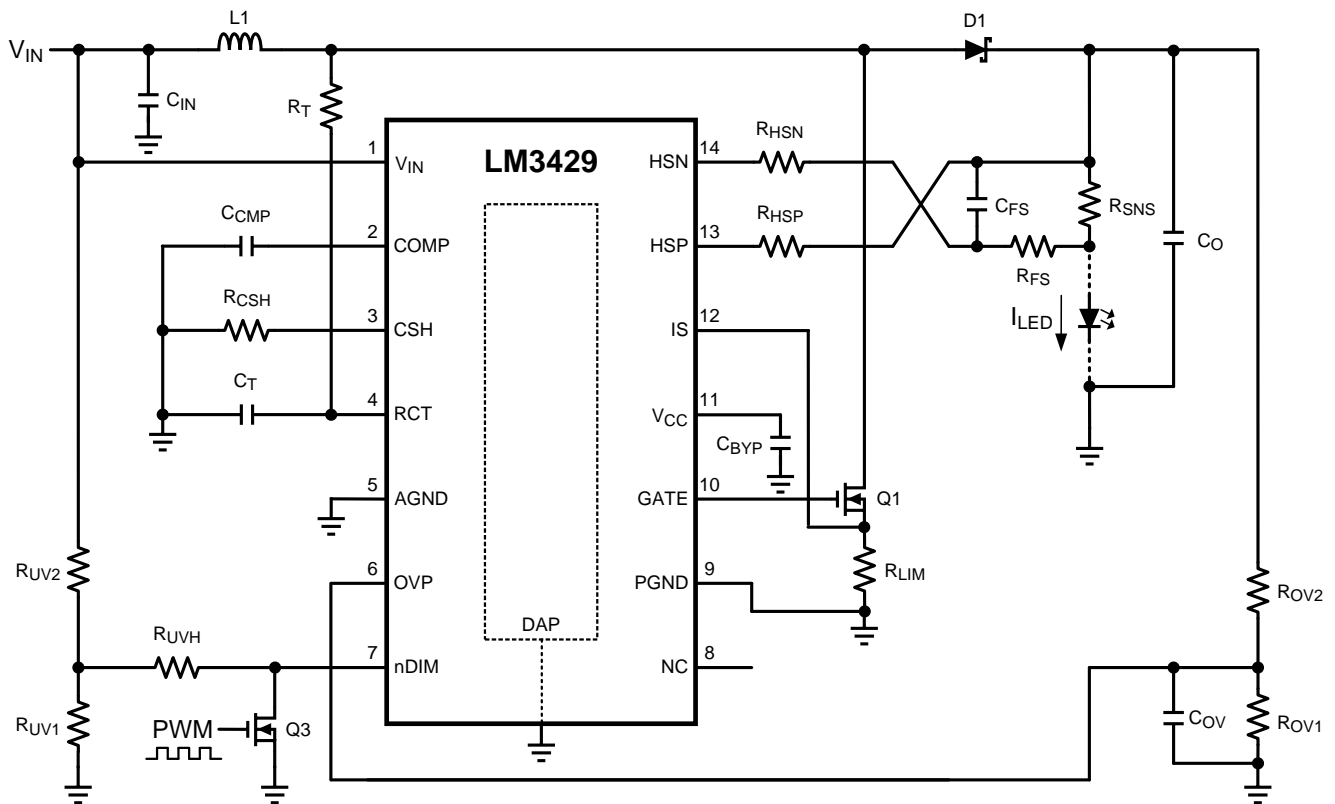

Figure 26. Boost Regulator ($V_{IN} < V_O$)

Typical Applications (continued)

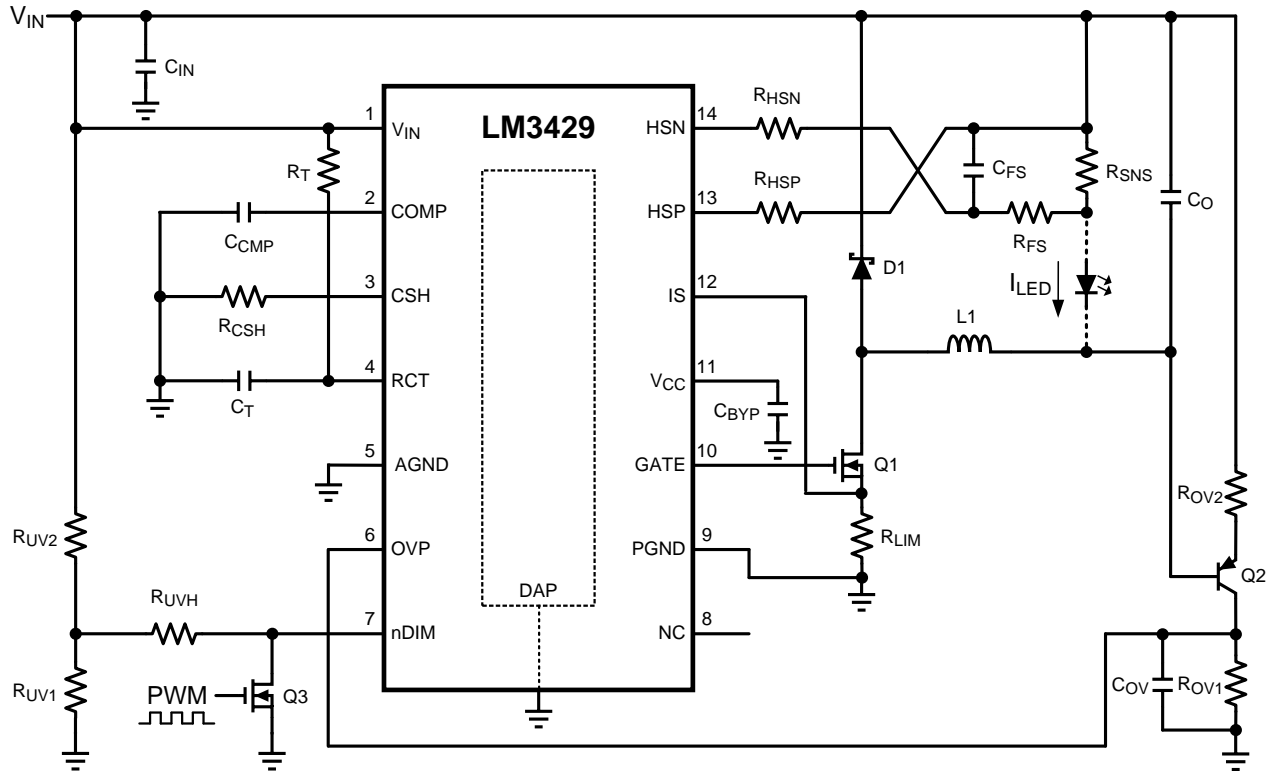
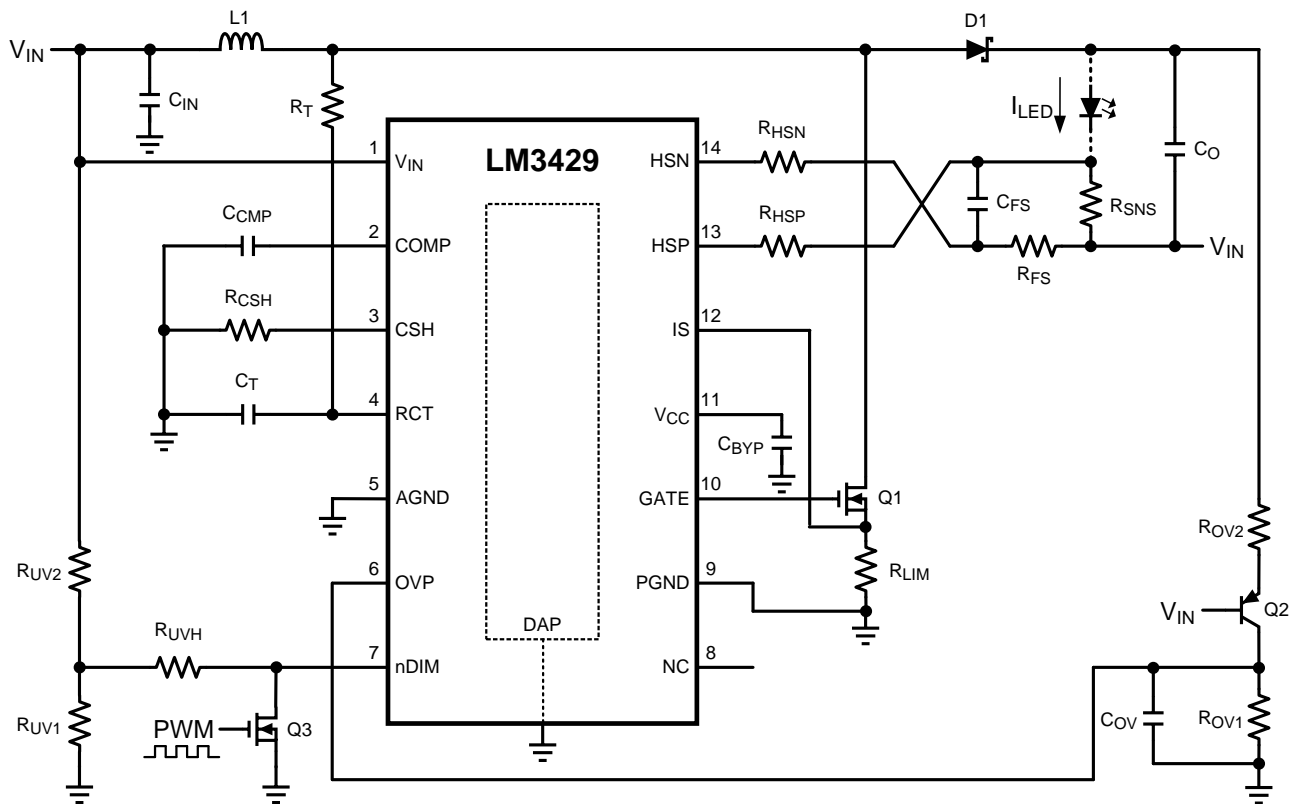

Figure 27. Buck Regulator ($V_{IN} > V_O$)

Typical Applications (continued)

Figure 28. Buck-Boost Regulator
8.2.1.1 Design Requirements

 Number of series LEDs: N

 Single LED forward voltage: V_{LED}

 Single LED dynamic resistance: r_{LED}

 Nominal input voltage: V_{IN}

 Input voltage range: V_{IN-MAX} , V_{IN-MIN}

 Switching frequency: f_{SW}

 Current sense voltage: V_{SNS}

 Average LED current: I_{LED}

 Inductor current ripple: Δi_{L-PP}

 LED current ripple: Δi_{LED-PP}

 Peak current limit: I_{LIM}

 Input voltage ripple: ΔV_{IN-PP}

 Output OVLO characteristics: $V_{TURN-OFF}$, V_{HYSD}

 Input UVLO characteristics: $V_{TURN-ON}$, V_{HYS}

Typical Applications (continued)

8.2.1.2 Detailed Design Procedure

8.2.1.2.1 Operating Point

Given the number of series LEDs (N), the forward voltage (V_{LED}) and dynamic resistance (r_{LED}) for a single LED, solve for the nominal output voltage (V_O) and the nominal LED string dynamic resistance (r_D):

$$V_O = N \times V_{LED} \quad (27)$$

$$r_D = N \times r_{LED} \quad (28)$$

Solve for the ideal nominal duty cycle (D):

Buck

$$D = \frac{V_O}{V_{IN}} \quad (29)$$

Boost

$$D = \frac{V_O - V_{IN}}{V_O} \quad (30)$$

Buck-boost

$$D = \frac{V_O}{V_O + V_{IN}} \quad (31)$$

Using the same equations, find the minimum duty cycle (D_{MIN}) using maximum input voltage (V_{IN-MAX}) and the maximum duty cycle (D_{MAX}) using the minimum input voltage (V_{IN-MIN}). Also, remember that $D' = 1 - D$.

8.2.1.2.2 Switching Frequency

Set the switching frequency (f_{SW}) by assuming a C_T value of 1 nF and solving for R_T :

Buck (Constant Ripple vs. V_{IN})

$$R_T = \frac{25 \times (V_{IN} - V_O)}{f_{SW} \times C_T \times V_{IN}} \quad (32)$$

Buck (Constant Ripple vs. V_O)

$$R_T = \frac{25 \times (V_{IN} \times V_O - V_O^2)}{f_{SW} \times C_T \times V_{IN}^2} \quad (33)$$

Boost and Buck-Boost

$$R_T = \frac{25}{f_{SW} \times C_T} \quad (34)$$

8.2.1.2.3 Average LED Current

For all topologies, set the average LED current (I_{LED}) knowing the desired current sense voltage (V_{SNS}) and solving for R_{SNS} :

$$R_{SNS} = \frac{V_{SNS}}{I_{LED}} \quad (35)$$

If the calculated R_{SNS} is too far from a desired standard value, then V_{SNS} must be adjusted to obtain a standard value.

Typical Applications (continued)

Setup the suggested signal current of 100 μA by assuming $R_{\text{CSH}} = 12.4 \text{ k}\Omega$ and solving for R_{HSP} :

$$R_{\text{HSP}} = \frac{I_{\text{LED}} \times R_{\text{CSH}} \times R_{\text{SNS}}}{1.24\text{V}} \quad (36)$$

If the calculated R_{HSP} is too far from a desired standard value, then R_{CSH} can be adjusted to obtain a standard value.

8.2.1.2.4 Inductor Ripple Current

Set the nominal inductor ripple current ($\Delta i_{\text{L-PP}}$) by solving for the appropriate inductor (L1):

Buck

$$L1 = \frac{(V_{\text{IN}} - V_{\text{O}}) \times D}{\Delta i_{\text{L-PP}} \times f_{\text{SW}}} \quad (37)$$

Boost and Buck-Boost

$$L1 = \frac{V_{\text{IN}} \times D}{\Delta i_{\text{L-PP}} \times f_{\text{SW}}} \quad (38)$$

To set the worst case inductor ripple current, use $V_{\text{IN-MAX}}$ and D_{MIN} when solving for L1.

The minimum allowable inductor RMS current rating ($I_{\text{L-RMS}}$) can be calculated as:

Buck

$$I_{\text{L-RMS}} = I_{\text{LED}} \times \sqrt{1 + \frac{1}{12} \times \left(\frac{\Delta i_{\text{L-PP}}}{I_{\text{LED}}} \right)^2} \quad (39)$$

Boost and Buck-Boost

$$I_{\text{L-RMS}} = \frac{I_{\text{LED}}}{D'} \times \sqrt{1 + \frac{1}{12} \times \left(\frac{\Delta i_{\text{L-PP}} \times D'}{I_{\text{LED}}} \right)^2} \quad (40)$$

8.2.1.2.5 LED Ripple Current

Set the nominal LED ripple current ($\Delta i_{\text{LED-PP}}$), by solving for the output capacitance (C_{O}):

Buck

$$C_{\text{O}} = \frac{\Delta i_{\text{L-PP}}}{8 \times f_{\text{SW}} \times r_{\text{D}} \times \Delta i_{\text{LED-PP}}} \quad (41)$$

Boost and Buck-Boost

$$C_{\text{O}} = \frac{I_{\text{LED}} \times D}{r_{\text{D}} \times \Delta i_{\text{LED-PP}}} \quad (42)$$

To set the worst case LED ripple current, use D_{MAX} when solving for C_{O} .

The minimum allowable RMS output capacitor current rating ($I_{\text{CO-RMS}}$) can be approximated:

Buck

$$I_{\text{CO-RMS}} = \frac{\Delta i_{\text{LED-PP}}}{\sqrt{12}} \quad (43)$$

Typical Applications (continued)

Boost and Buck-boost

$$I_{CO-RMS} = I_{LED} \times \sqrt{\frac{D_{MAX}}{1-D_{MAX}}} \quad (44)$$

8.2.1.2.6 Peak Current Limit

Set the peak current limit (I_{LIM}) by solving for the transistor path sense resistor (R_{LIM}):

$$R_{LIM} = \frac{245 \text{ mV}}{I_{LIM}} \quad (45)$$

8.2.1.2.7 Loop Compensation

Using a simple first order peak current mode control model, neglecting any output capacitor ESR dynamics, the necessary loop compensation can be determined.

First, the uncompensated loop gain (T_U) of the regulator can be approximated:

Buck

$$T_U = T_{U0} \times \frac{1}{\left(1 + \frac{s}{\omega_{P1}}\right)} \quad (46)$$

Boost and Buck-Boost

$$T_U = T_{U0} \times \frac{\left(1 - \frac{s}{\omega_{Z1}}\right)}{\left(1 + \frac{s}{\omega_{P1}}\right)} \quad (47)$$

Where the pole (ω_{P1}) is approximated:

Buck

$$\omega_{P1} = \frac{1}{r_D \times C_O} \quad (48)$$

Boost

$$\omega_{P1} = \frac{2}{r_D \times C_O} \quad (49)$$

Buck-Boost

$$\omega_{P1} = \frac{1+D}{r_D \times C_O} \quad (50)$$

And the RHP zero (ω_{Z1}) is approximated:

Boost

$$\omega_{Z1} = \frac{r_D \times D^2}{L1} \quad (51)$$

Buck-Boost

$$\omega_{Z1} = \frac{r_D \times D^2}{D \times L1} \quad (52)$$

Typical Applications (continued)

And the uncompensated DC loop gain (T_{U0}) is approximated:

Buck

$$T_{U0} = \frac{500V \times R_{CSH} \times R_{SNS}}{R_{HSP} \times R_{LIM}} = \frac{620V}{I_{LED} \times R_{LIM}} \quad (53)$$

Boost

$$T_{U0} = \frac{D' \times 500V \times R_{CSH} \times R_{SNS}}{2 \times R_{HSP} \times R_{LIM}} = \frac{D' \times 310V}{I_{LED} \times R_{LIM}} \quad (54)$$

Buck-Boost

$$T_{U0} = \frac{D' \times 500V \times R_{CSH} \times R_{SNS}}{(1+D) \times R_{HSP} \times R_{LIM}} = \frac{D' \times 620V}{(1+D) \times I_{LED} \times R_{LIM}} \quad (55)$$

For all topologies, the primary method of compensation is to place a low-frequency dominant pole (ω_{P2}) which will ensure that there is ample phase margin at the crossover frequency. This is accomplished by placing a capacitor (C_{CMP}) from the COMP pin to GND, which is calculated according to the lower value of the pole and the RHP zero of the system (shown as a minimizing function):

$$\omega_{P2} = \frac{\min(\omega_{P1}, \omega_{Z1})}{5 \times T_{U0}} \quad (56)$$

$$C_{CMP} = \frac{1}{\omega_{P2} \times 5 \times 10^6} \quad (57)$$

If analog dimming is used, C_{CMP} should be approximately 4x larger to maintain stability as the LEDs are dimmed to zero.

A high frequency compensation pole (ω_{P3}) can be used to attenuate switching noise and provide better gain margin. Assuming $R_{FS} = 10 \Omega$, C_{FS} is calculated according to the higher value of the pole and the RHP zero of the system (shown as a maximizing function):

$$\omega_{P3} = \max(\omega_{P1}, \omega_{Z1}) \times 10 \quad (58)$$

$$C_{FS} = \frac{1}{10 \times \omega_{P3}} \quad (59)$$

The total system loop gain (T) can then be written as:

Buck

$$T = T_{U0} \times \frac{1}{\left(1 + \frac{s}{\omega_{P1}}\right) \times \left(1 + \frac{s}{\omega_{P2}}\right) \times \left(1 + \frac{s}{\omega_{P3}}\right)} \quad (60)$$

Boost and Buck-boost

$$T = T_{U0} \times \frac{\left(1 - \frac{s}{\omega_{Z1}}\right)}{\left(1 + \frac{s}{\omega_{P1}}\right) \times \left(1 + \frac{s}{\omega_{P2}}\right) \times \left(1 + \frac{s}{\omega_{P3}}\right)} \quad (61)$$

8.2.1.2.8 Input Capacitance

Set the nominal input voltage ripple (Δv_{IN-PP}) by solving for the required capacitance (C_{IN}):

Buck

Typical Applications (continued)

$$C_{IN} = \frac{I_{LED} \times (1 - D) \times D}{\Delta V_{IN-PP} \times f_{SW}} \quad (62)$$

Boost

$$C_{IN} = \frac{\Delta i_{L-PP}}{8 \times \Delta V_{IN-PP} \times f_{SW}} \quad (63)$$

Buck-Boost

$$C_{IN} = \frac{I_{LED} \times D}{\Delta V_{IN-PP} \times f_{SW}} \quad (64)$$

Use D_{MAX} to set the worst case input voltage ripple, when solving for C_{IN} in a buck-boost regulator and $D_{MID} = 0.5$ when solving for C_{IN} in a buck regulator.

The minimum allowable RMS input current rating ($I_{CIN-RMS}$) can be approximated:

Buck

$$I_{CIN-RMS} = I_{LED} \times \sqrt{D_{MID} \times (1 - D_{MID})} \quad (65)$$

Boost

$$I_{CIN-RMS} = \frac{\Delta i_{L-PP}}{\sqrt{12}} \quad (66)$$

Buck-Boost

$$I_{CIN-RMS} = I_{LED} \times \sqrt{\frac{D_{MAX}}{1 - D_{MAX}}} \quad (67)$$

8.2.1.2.9 NFET

The NFET voltage rating should be at least 15% higher than the maximum NFET drain-to-source voltage (V_{T-MAX}):

Buck

$$V_{T-MAX} = V_{IN-MAX} \quad (68)$$

Boost

$$V_{T-MAX} = V_O \quad (69)$$

Buck-Boost

$$V_{T-MAX} = V_{IN-MAX} + V_O \quad (70)$$

The current rating should be at least 10% higher than the maximum average NFET current (I_{T-MAX}):

Buck

$$I_{T-MAX} = D_{MAX} \times I_{LED} \quad (71)$$

Boost and Buck-Boost

$$I_{T-MAX} = \frac{D_{MAX}}{1 - D_{MAX}} \times I_{LED} \quad (72)$$

Approximate the nominal RMS transistor current (I_{T-RMS}):

Buck

Typical Applications (continued)

$$I_{T-RMS} = I_{LED} \times \sqrt{D} \quad (73)$$

Boost and Buck-Boost

$$I_{T-RMS} = \frac{I_{LED}}{D'} \times \sqrt{D} \quad (74)$$

 Given an NFET with on-resistance (R_{DS-ON}), solve for the nominal power dissipation (P_T):

$$P_T = I_{T-RMS}^2 \times R_{DS-ON} \quad (75)$$

8.2.1.2.10 Diode

 The Schottky diode voltage rating should be at least 15% higher than the maximum blocking voltage (V_{RD-MAX}):

Buck

$$V_{RD-MAX} = V_{IN-MAX} \quad (76)$$

Boost

$$V_{RD-MAX} = V_O \quad (77)$$

Buck-Boost

$$V_{RD-MAX} = V_{IN-MAX} + V_O \quad (78)$$

 The current rating should be at least 10% higher than the maximum average diode current (I_{D-MAX}):

Buck

$$I_{D-MAX} = (1 - D_{MIN}) \times I_{LED} \quad (79)$$

Boost and Buck-Boost

$$I_{D-MAX} = I_{LED} \quad (80)$$

 Replace D_{MAX} with D in the I_{D-MAX} equation to solve for the average diode current (I_D). Given a diode with forward voltage (V_{FD}), solve for the nominal power dissipation (P_D):

$$P_D = I_D \times V_{FD} \quad (81)$$

8.2.1.2.11 Output OVLO

 For boost and buck-boost regulators, output OVLO is programmed with the turn-off threshold voltage ($V_{TURN-OFF}$) and the desired hysteresis (V_{HYSO}). To set V_{HYSO} , solve for R_{OV2} :

$$R_{OV2} = \frac{V_{HYSO}}{20 \mu A} \quad (82)$$

 To set $V_{TURN-OFF}$, solve for R_{OV1} :

Boost

$$R_{OV1} = \frac{1.24V \times R_{OV2}}{V_{TURN-OFF} - 1.24V} \quad (83)$$

Buck-Boost

$$R_{OV1} = \frac{1.24V \times R_{OV2}}{V_{TURN-OFF} - 620 \text{ mV}} \quad (84)$$

Typical Applications (continued)

A small filter capacitor ($C_{OVP} = 47 \text{ pF}$) should be added from the OVP pin to ground to reduce coupled switching noise.

8.2.1.2.12 Input UVLO

For all topologies, input UVLO is programmed with the turn-on threshold voltage ($V_{\text{TURN-ON}}$) and the desired hysteresis (V_{HYS}).

Method #1: If no PWM dimming is required, a two resistor network can be used. To set V_{HYS} , solve for R_{UV2} :

$$R_{\text{UV2}} = \frac{V_{\text{HYS}}}{20 \mu\text{A}} \quad (85)$$

To set $V_{\text{TURN-ON}}$, solve for R_{UV1} :

$$R_{\text{UV1}} = \frac{1.24\text{V} \times R_{\text{UV2}}}{V_{\text{TURN-ON}} - 1.24\text{V}} \quad (86)$$

Method #2: If PWM dimming is required, a three resistor network is suggested. To set $V_{\text{TURN-ON}}$, assume $R_{\text{UV2}} = 10 \text{ k}\Omega$ and solve for R_{UV1} as in Method #1. To set V_{HYS} , solve for R_{UVH} :

$$R_{\text{UVH}} = \frac{R_{\text{UV1}} \times (V_{\text{HYS}} - 20 \mu\text{A} \times R_{\text{UV2}})}{20 \mu\text{A} \times (R_{\text{UV1}} + R_{\text{UV2}})} \quad (87)$$

8.2.1.2.13 PWM Dimming Method

PWM dimming can be performed several ways:

Method #1: Connect the dimming MosFET (Q_3) with the drain to the nDIM pin and the source to GND. Apply an external PWM signal to the gate of Q_{DIM} . A pull down resistor may be necessary to properly turn off Q_3 .

Method #2: Connect the anode of a Schottky diode to the nDIM pin. Apply an external inverted PWM signal to the cathode of the same diode.

8.2.1.2.14 Analog Dimming Method

Analog dimming can be performed several ways:

Method #1: Place a potentiometer in series with the R_{CSH} resistor to dim the LED current from the nominal I_{LED} to near zero.

Method #2: Connect a controlled current source as detailed in the [Analog Dimming](#) section to the CSH pin. Increasing the current sourced into the CSH node will decrease the LEDs from the nominal I_{LED} to zero current.

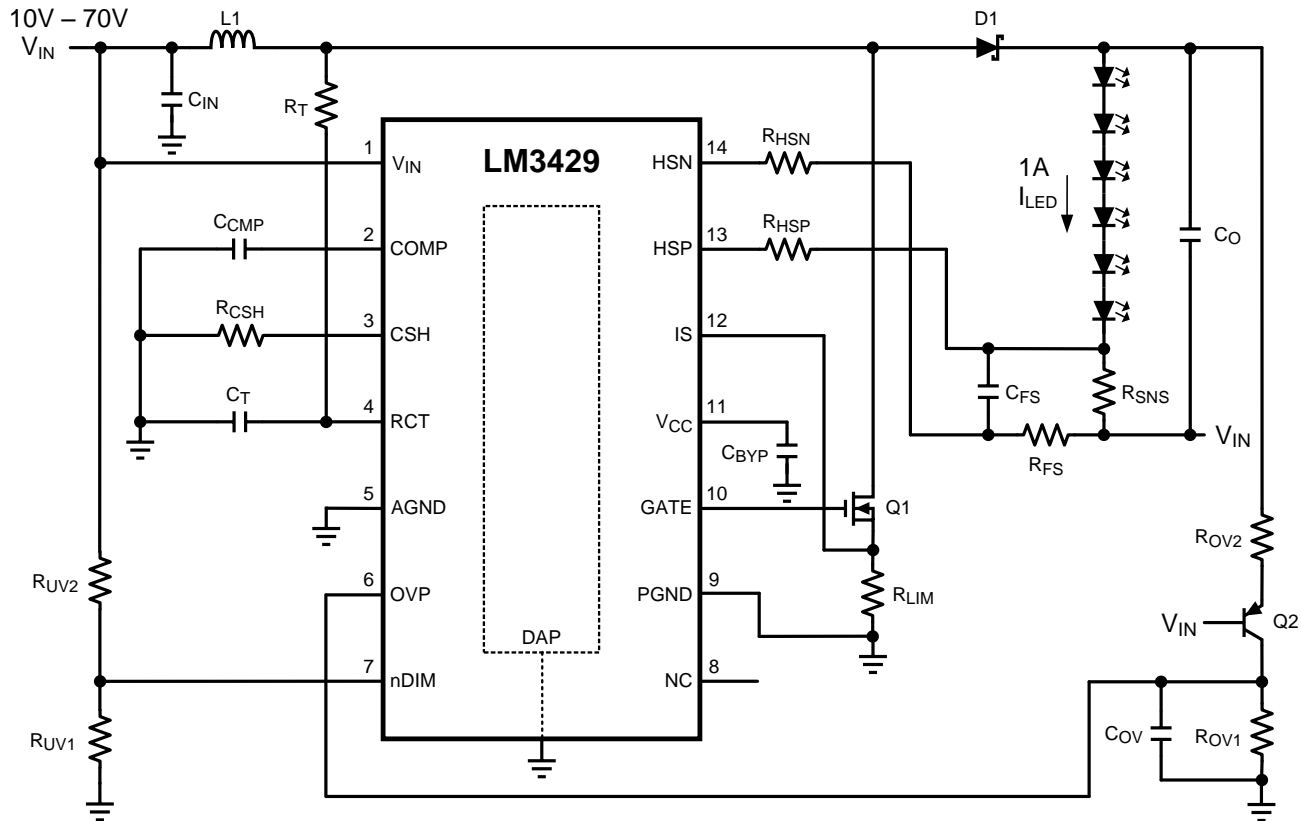
Typical Applications (continued)
8.2.2 Buck-Boost Application - 6 LEDs at 1 A

Figure 29. Buck-Boost Application - 6 LEDs at 1 A Schematic
8.2.2.1 Design Requirements

$$N = 6$$

$$V_{LED} = 3.5 \text{ V}$$

$$r_{LED} = 325 \text{ m}\Omega$$

$$V_{IN} = 24 \text{ V}$$

$$V_{IN-MIN} = 10 \text{ V}$$

$$V_{IN-MAX} = 70 \text{ V}$$

$$f_{SW} = 700 \text{ kHz}$$

$$V_{SNS} = 100 \text{ mV}$$

$$I_{LED} = 1 \text{ A}$$

$$\Delta i_{L-PP} = 500 \text{ mA}$$

$$\Delta i_{LED-PP} = 50 \text{ mA}$$

$$\Delta v_{IN-PP} = 100 \text{ mV}$$

$$I_{LIM} = 6 \text{ A}$$

$$V_{TURN-ON} = 10 \text{ V}$$

$$V_{HYS} = 3 \text{ V}$$

Typical Applications (continued)

$$V_{\text{TURN-OFF}} = 40 \text{ V}$$

$$V_{\text{HYSO}} = 10 \text{ V}$$

8.2.2.2 Detailed Design Procedure

8.2.2.2.1 Operating Point

Solve for V_O and r_D :

$$V_O = N \times V_{\text{LED}} = 6 \times 3.5\text{V} = 21\text{V} \quad (88)$$

$$r_D = N \times r_{\text{LED}} = 6 \times 325 \text{ m}\Omega = 1.95\Omega \quad (89)$$

Solve for D , D' , D_{MAX} , and D_{MIN} :

$$D = \frac{V_O}{V_O + V_{\text{IN}}} = \frac{21\text{V}}{21\text{V} + 24\text{V}} = 0.467 \quad (90)$$

$$D' = 1 - D = 1 - 0.467 = 0.533 \quad (91)$$

$$D_{\text{MIN}} = \frac{V_O}{V_O + V_{\text{IN-MAX}}} = \frac{21\text{V}}{21\text{V} + 70\text{V}} = 0.231 \quad (92)$$

$$D_{\text{MAX}} = \frac{V_O}{V_O + V_{\text{IN-MIN}}} = \frac{21\text{V}}{21\text{V} + 10\text{V}} = 0.677 \quad (93)$$

8.2.2.2.2 Switching Frequency

Assume $C_T = 1 \text{ nF}$ and solve for R_T :

$$R_T = \frac{25}{f_{\text{SW}} \times C_T} = \frac{25}{700 \text{ kHz} \times 1 \text{ nF}} = 35.7 \text{ k}\Omega \quad (94)$$

The closest standard resistor is actually $35.7 \text{ k}\Omega$ therefore the f_{SW} is:

$$f_{\text{SW}} = \frac{25}{R_T \times C_T} = \frac{25}{35.7 \text{ k}\Omega \times 1 \text{ nF}} = 700 \text{ kHz} \quad (95)$$

The chosen components from step 2 are:

$C_T = 1 \text{ nF}$
$R_T = 35.7 \text{ k}\Omega$

(96)

8.2.2.2.3 Average LED Current

Solve for R_{SNS} :

$$R_{\text{SNS}} = \frac{V_{\text{SNS}}}{I_{\text{LED}}} = \frac{100 \text{ mV}}{1\text{A}} = 0.1\Omega \quad (97)$$

Assume $R_{\text{CSH}} = 12.4 \text{ k}\Omega$ and solve for R_{HSP} :

$$R_{\text{HSP}} = \frac{I_{\text{LED}} \times R_{\text{CSH}} \times R_{\text{SNS}}}{1.24\text{V}} = \frac{1\text{A} \times 12.4 \text{ k}\Omega \times 0.1\Omega}{1.24\text{V}} = 1.0 \text{ k}\Omega \quad (98)$$

The closest standard resistor for R_{SNS} is actually 0.1Ω and for R_{HSP} is actually $1 \text{ k}\Omega$ therefore I_{LED} is:

$$I_{\text{LED}} = \frac{1.24\text{V} \times R_{\text{HSP}}}{R_{\text{SNS}} \times R_{\text{CSH}}} = \frac{1.24\text{V} \times 1.0 \text{ k}\Omega}{0.1\Omega \times 12.4 \text{ k}\Omega} = 1.0\text{A} \quad (99)$$

The chosen components from step 3 are:

Typical Applications (continued)

$$\begin{aligned} R_{\text{SNS}} &= 0.1\Omega \\ R_{\text{CSH}} &= 12.4\text{ k}\Omega \\ R_{\text{HSP}} = R_{\text{HSN}} &= 1\text{ k}\Omega \end{aligned} \quad (100)$$

8.2.2.2.4 Inductor Ripple Current

Solve for L1:

$$L1 = \frac{V_{\text{IN}} \times D}{\Delta i_{\text{L-PP}} \times f_{\text{SW}}} = \frac{24\text{V} \times 0.467}{500\text{ mA} \times 700\text{ kHz}} = 32\ \mu\text{H} \quad (101)$$

The closest standard inductor is 33 μH therefore the actual $\Delta i_{\text{L-PP}}$ is:

$$\Delta i_{\text{L-PP}} = \frac{V_{\text{IN}} \times D}{L1 \times f_{\text{SW}}} = \frac{24\text{V} \times 0.467}{33\ \mu\text{H} \times 700\text{ kHz}} = 485\text{ mA} \quad (102)$$

Determine minimum allowable RMS current rating:

$$\begin{aligned} I_{\text{L-RMS}} &= \frac{I_{\text{LED}}}{D'} \times \sqrt{1 + \frac{1}{12} \times \left(\frac{\Delta i_{\text{L-PP}} \times D'}{I_{\text{LED}}} \right)^2} \\ I_{\text{L-RMS}} &= \frac{1\text{A}}{0.533} \times \sqrt{1 + \frac{1}{12} \times \left(\frac{485\text{ mA} \times 0.533}{1\text{A}} \right)^2} \\ I_{\text{L-RMS}} &= 1.88\text{A} \end{aligned} \quad (103)$$

The chosen component from step 4 is:

$$L1 = 33\ \mu\text{H} \quad (104)$$

8.2.2.2.5 Output Capacitance

Solve for C_{O} :

$$\begin{aligned} C_{\text{O}} &= \frac{I_{\text{LED}} \times D}{r_{\text{D}} \times \Delta i_{\text{LED-PP}} \times f_{\text{SW}}} \\ C_{\text{O}} &= \frac{1\text{A} \times 0.467}{1.95\Omega \times 50\text{ mA} \times 700\text{ kHz}} = 6.84\ \mu\text{F} \end{aligned} \quad (105)$$

The closest standard capacitor is 6.8 μF therefore the actual $\Delta i_{\text{LED-PP}}$ is:

$$\begin{aligned} \Delta i_{\text{LED-PP}} &= \frac{I_{\text{LED}} \times D}{r_{\text{D}} \times C_{\text{O}} \times f_{\text{SW}}} \\ \Delta i_{\text{LED-PP}} &= \frac{1\text{A} \times 0.467}{1.95\Omega \times 6.8\ \mu\text{F} \times 700\text{ kHz}} = 50\text{ mA} \end{aligned} \quad (106)$$

Determine minimum allowable RMS current rating:

$$I_{\text{CO-RMS}} = I_{\text{LED}} \times \sqrt{\frac{D_{\text{MAX}}}{1 - D_{\text{MAX}}}} = 1\text{A} \times \sqrt{\frac{0.677}{1 - 0.677}} = 1.45\text{A} \quad (107)$$

The chosen components from step 5 are:

$$C_{\text{O}} = 6.8\ \mu\text{F} \quad (108)$$

Typical Applications (continued)

8.2.2.2.6 Peak Current Limit

Solve for R_{LIM} :

$$R_{LIM} = \frac{245 \text{ mV}}{I_{LIM}} = \frac{245 \text{ mV}}{6 \text{ A}} = 0.041 \Omega \quad (109)$$

The closest standard resistor is 0.04 Ω therefore I_{LIM} is:

$$I_{LIM} = \frac{245 \text{ mV}}{R_{LIM}} = \frac{245 \text{ mV}}{0.04 \Omega} = 6.13 \text{ A} \quad (110)$$

The chosen component from step 6 is:

$$\boxed{R_{LIM} = 0.04 \Omega} \quad (111)$$

8.2.2.2.7 Loop Compensation

ω_{P1} is approximated:

$$\omega_{P1} = \frac{1 + D}{r_D \times C_O} = \frac{1.467}{1.95 \Omega \times 6.8 \mu\text{F}} = 110 \text{ k} \frac{\text{rad}}{\text{sec}} \quad (112)$$

ω_{Z1} is approximated:

$$\omega_{Z1} = \frac{r_D \times D'^2}{D \times L1} = \frac{1.95 \Omega \times 0.533^2}{0.467 \times 33 \mu\text{H}} = 37 \text{ k} \frac{\text{rad}}{\text{sec}} \quad (113)$$

T_{U0} is approximated:

$$T_{U0} = \frac{D' \times 620 \text{ V}}{(1 + D) \times I_{LED} \times R_{LIM}} = \frac{0.533 \times 620 \text{ V}}{1.467 \times 1 \text{ A} \times 0.04 \Omega} = 5630 \quad (114)$$

To ensure stability, calculate ω_{P2} :

$$\omega_{P2} = \frac{\min(\omega_{P1}, \omega_{Z1})}{5 \times T_{U0}} = \frac{\omega_{Z1}}{5 \times 5630} = \frac{37 \text{ k} \frac{\text{rad}}{\text{sec}}}{5 \times 5630} = 1.173 \frac{\text{rad}}{\text{sec}} \quad (115)$$

Solve for C_{CMP} :

$$C_{CMP} = \frac{1}{\omega_{P2} \times 5 \times 10^6 \Omega} = \frac{1}{1.173 \frac{\text{rad}}{\text{sec}} \times 5 \times 10^6 \Omega} = 0.17 \mu\text{F} \quad (116)$$

To attenuate switching noise, calculate ω_{P3} :

$$\begin{aligned} \omega_{P3} &= \max(\omega_{P1}, \omega_{Z1}) \times 10 = \omega_{P1} \times 10 \\ \omega_{P3} &= 110 \text{ k} \frac{\text{rad}}{\text{sec}} \times 10 = 1.1 \text{ M} \frac{\text{rad}}{\text{sec}} \end{aligned} \quad (117)$$

Assume $R_{FS} = 10 \Omega$ and solve for C_{FS} :

$$C_{FS} = \frac{1}{10 \Omega \times \omega_{P3}} = \frac{1}{10 \Omega \times 1.1 \text{ M} \frac{\text{rad}}{\text{sec}}} = 0.091 \mu\text{F} \quad (118)$$

The chosen components from step 7 are:

$$\boxed{\begin{aligned} C_{COMP} &= 0.22 \mu\text{F} \\ R_{FS} &= 10 \Omega \\ C_{FS} &= 0.1 \mu\text{F} \end{aligned}} \quad (119)$$

Typical Applications (continued)

8.2.2.2.8 Input Capacitance

Solve for the minimum C_{IN} :

$$C_{IN} = \frac{I_{LED} \times D}{\Delta V_{IN-PP} \times f_{SW}} = \frac{1A \times 0.467}{100 \text{ mV} \times 700 \text{ kHz}} = 6.66 \mu\text{F} \quad (120)$$

To minimize power supply interaction a 200% larger capacitance of approximately 14 μF is used, therefore the actual ΔV_{IN-PP} is much lower. Because high voltage ceramic capacitor selection is limited, three 4.7 μF X7R capacitors are chosen.

Determine minimum allowable RMS current rating:

$$I_{IN-RMS} = I_{LED} \times \sqrt{\frac{D_{MAX}}{1 - D_{MAX}}} = 1A \times \sqrt{\frac{0.677}{1 - 0.677}} = 1.45A \quad (121)$$

The chosen components from step 8 are:

$$C_{IN} = 3 \times 4.7 \mu\text{F} \quad (122)$$

8.2.2.2.9 NFET

Determine minimum Q1 voltage rating and current rating:

$$V_{T-MAX} = V_{IN-MAX} + V_O = 70V + 21V = 91V \quad (123)$$

$$I_{T-MAX} = \frac{0.677}{1 - 0.677} \times 1A = 2.1A \quad (124)$$

A 100-V NFET is chosen with a current rating of 32A due to the low $R_{DS-ON} = 50 \text{ m}\Omega$. Determine I_{T-RMS} and P_T :

$$I_{T-RMS} = \frac{I_{LED}}{D'} \times \sqrt{D} = \frac{1A}{0.533} \times \sqrt{0.467} = 1.28A \quad (125)$$

$$P_T = I_{T-RMS}^2 \times R_{DS-ON} = 1.28A^2 \times 50 \text{ m}\Omega = 82 \text{ mW} \quad (126)$$

The chosen component from step 9 is:

$$Q1 \rightarrow 32A, 100V, \text{ DPAK} \quad (127)$$

8.2.2.2.10 Diode

Determine minimum D1 voltage rating and current rating:

$$V_{RD-MAX} = V_{IN-MAX} + V_O = 70V + 21V = 91V \quad (128)$$

$$I_{D-MAX} = I_{LED} = 1A \quad (129)$$

A 100-V diode is chosen with a current rating of 12 A and $V_{DF} = 600 \text{ mV}$. Determine P_D :

$$P_D = I_D \times V_{DF} = 1A \times 600 \text{ mV} = 600 \text{ mW} \quad (130)$$

The chosen component from step 10 is:

$$D1 \rightarrow 12A, 100V, \text{ DPAK} \quad (131)$$

8.2.2.2.11 Input UVLO

Solve for R_{UV2} :

Typical Applications (continued)

$$R_{UV2} = \frac{V_{HYS}}{20 \mu A} = \frac{3V}{20 \mu A} = 150 \text{ k}\Omega \quad (132)$$

The closest standard resistor is 150 kΩ therefore V_{HYS} is:

$$V_{HYS} = R_{UV2} \times 20 \mu A = 150 \text{ k}\Omega \times 20 \mu A = 3V \quad (133)$$

Solve for R_{UV1} :

$$R_{UV1} = \frac{1.24V \times R_{UV2}}{V_{TURN-ON} - 1.24V} = \frac{1.24V \times 150 \text{ k}\Omega}{10V - 1.24V} = 21.2 \text{ k}\Omega \quad (134)$$

The closest standard resistor is 21 kΩ making $V_{TURN-ON}$:

$$V_{TURN-ON} = \frac{1.24V \times (R_{UV1} + R_{UV2})}{R_{UV1}}$$

$$V_{TURN-ON} = \frac{1.24V \times (21 \text{ k}\Omega + 150 \text{ k}\Omega)}{21 \text{ k}\Omega} = 10.1V \quad (135)$$

The chosen components from step 11 are:

$R_{UV1} = 21 \text{ k}\Omega$
$R_{UV2} = 150 \text{ k}\Omega$

(136)

8.2.2.2.12 Output OVLO

Solve for R_{OV2} :

$$R_{OV2} = \frac{V_{HYSO}}{20 \mu A} = \frac{10V}{20 \mu A} = 500 \text{ k}\Omega \quad (137)$$

The closest standard resistor is 499 kΩ therefore V_{HYSO} is:

$$V_{HYSO} = R_{OV2} \times 20 \mu A = 499 \text{ k}\Omega \times 20 \mu A = 9.98V \quad (138)$$

Solve for R_{OV1} :

$$R_{OV1} = \frac{1.24V \times R_{OV2}}{V_{TURN-OFF} - 0.62V} = \frac{1.24V \times 499 \text{ k}\Omega}{40V - 0.62V} = 15.7 \text{ k}\Omega \quad (139)$$

The closest standard resistor is 15.8 kΩ making $V_{TURN-OFF}$:

$$V_{TURN-OFF} = \frac{1.24V \times (0.5 \times R_{OV1} + R_{OV2})}{R_{OV1}}$$

$$V_{TURN-OFF} = \frac{1.24V \times (0.5 \times 15.8 \text{ k}\Omega + 499 \text{ k}\Omega)}{15.8 \text{ k}\Omega} = 39.8V \quad (140)$$

The chosen components from step 12 are:

$R_{OV1} = 15.8 \text{ k}\Omega$
$R_{OV2} = 499 \text{ k}\Omega$

(141)

Typical Applications (continued)
Table 1. Design 1 Bill of Materials

QTY	PART ID	PART VALUE	MANUFACTURER	PART NUMBER
1	LM3429	Boost controller	TI	LM3429MH
1	C _{CMP}	0.22 μ F X7R 10% 25 V	MURATA	GRM21BR71E224KA01L
1	C _F	2.2 μ F X7R 10% 16 V	MURATA	GRM21BR71C225KA12L
1	C _{FS}	0.1 μ F X7R 10% 25 V	MURATA	GRM21BR71E104KA01L
3	C _{IN}	4.7 μ F X7R 10% 100 V	TDK	C5750X7R2A475K
1	C _O	6.8 μ F X7R 10% 50 V	TDK	C4532X7R1H685K
1	C _{OV}	47 pF COG/NPO 5% 50 V	AVX	08055A470JAT2A
1	C _T	1000 pF COG/NPO 5% 50 V	MURATA	GRM2165C1H102JA01D
1	D1	Schottky 100 V 12 A	VISHAY	12CWQ10FNPBF
1	L1	33 μ H 20% 6.3 A	COILCRAFT	MSS1278-333MLB
1	Q1	NMOS 100 V 32 A	FAIRCHILD	FDD3682
1	Q2	PNP 150 V 600 m A	FAIRCHILD	MMBT5401
1	R _{CSH}	12.4 k Ω 1%	VISHAY	CRCW080512K4FKEA
1	R _{FS}	10 Ω 1%	VISHAY	CRCW080510R0FKEA
2	R _{HSP} , R _{HSN}	1 k Ω 1%	VISHAY	CRCW08051K00FKEA
1	R _{LIM}	0.04 Ω 1% 1W	VISHAY	WSL2512R0400FEA
1	R _{OV1}	15.8 k Ω 1%	VISHAY	CRCW080515K8FKEA
1	R _{OV2}	499 k Ω 1%	VISHAY	CRCW0805499KFKEA
1	R _{SNS}	0.1 Ω 1% 1W	VISHAY	WSL2512R1000FEA
1	R _T	35.7 k Ω 1%	VISHAY	CRCW080535K7FKEA
1	R _{UV1}	21 k Ω 1%	VISHAY	CRCW080521K0FKEA
1	R _{UV2}	150 k Ω 1%	VISHAY	CRCW0805150KFKEA

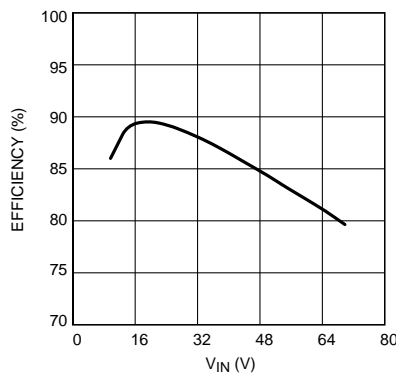
8.2.2.3 Application Curve

Figure 30. Buck-Boost Efficiency vs Input Voltage, V_O= 6 LEDs

8.2.3 Boost PWM Dimming Application - 9 LEDs at 1 A

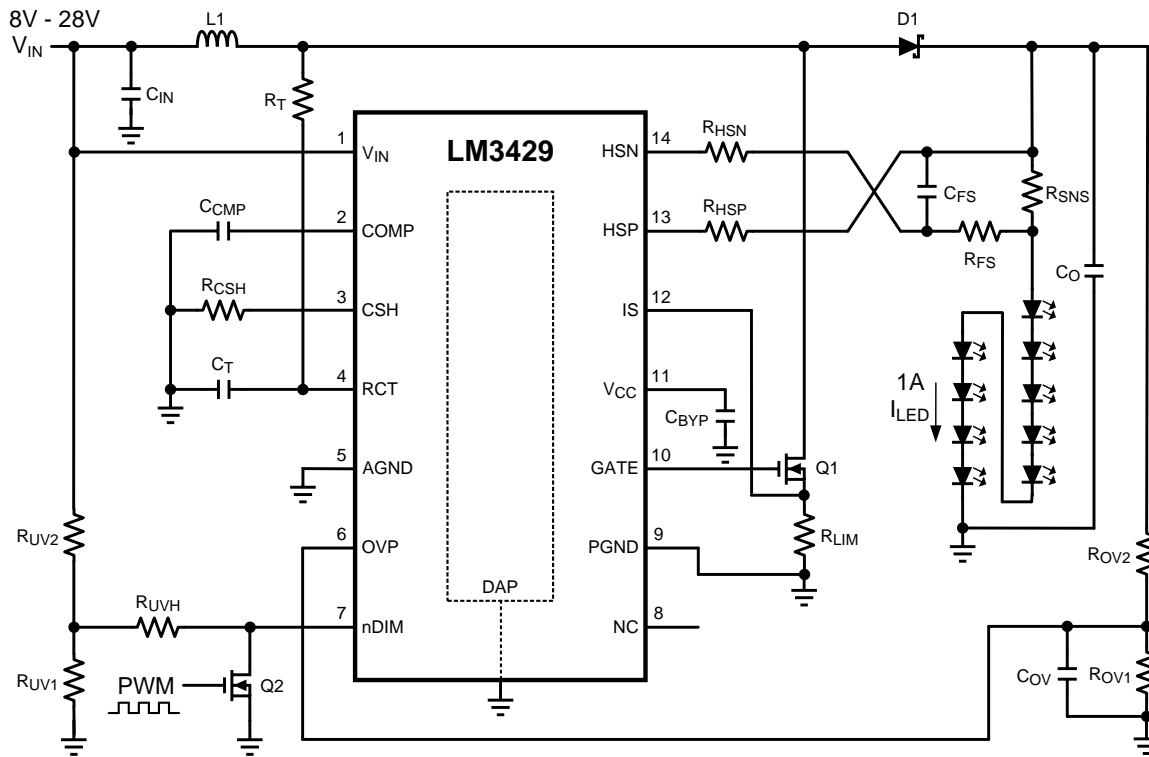
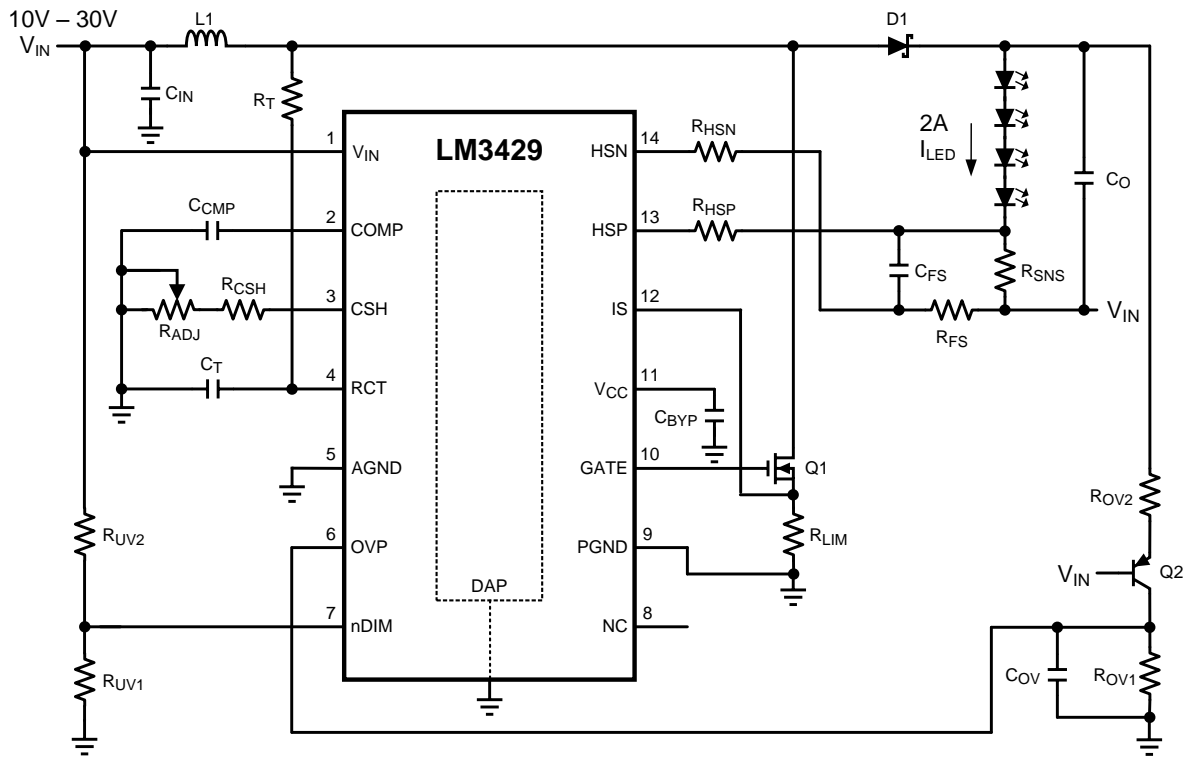

Figure 31. Boost PWM Dimming Application - 9 LEDs at 1 A Schematic

8.2.3.1 Detailed Design Procedure

Table 2. Design 2 Bill of Materials

QTY	PART ID	PART VALUE	MANUFACTURER	PART NUMBER
1	LM3429	Boost controller	TI	LM3429MH
2	C _{COMP} , C _{FS}	0.1 μF X7R 10% 25 V	MURATA	GRM21BR71E104KA01L
1	C _F	2.2 μF X7R 10% 16 V	MURATA	GRM21BR71C225KA12L
2, 1	C _{IN} , C _O	6.8 μF X7R 10% 50 V	TDK	C4532X7R1H685K
1	C _{OV}	47 pF COG/NPO 5% 50 V	AVX	08055A470JAT2A
1	C _T	1000 pF COG/NPO 5% 50 V	MURATA	GRM2165C1H102JA01D
1	D1	Schottky 60 V 5 A	COMCHIP	CDBC560-G
1	L1	33 μH 20% 6.3 A	COILCRAFT	MSS1278-333MLB
1	Q1	NMOS 60 V 8 A	VISHAY	SI4436DY
1	Q2	NMOS 60 V 115 mA	ON SEMI	2N7002ET1G
2	R _{CSH} , R _{OV1}	12.4 kΩ 1%	VISHAY	CRCW080512K4FKEA
1	R _{FS}	10 Ω 1%	VISHAY	CRCW080510R0FKEA
2	R _{HSP} , R _{HSN}	1 kΩ 1%	VISHAY	CRCW08051K00FKEA
1	R _{LIM}	0.06 Ω 1% 1 W	VISHAY	WSL2512R0600FEA
1	R _{OV2}	499 kΩ 1%	VISHAY	CRCW0805499KFKEA
1	R _{SNS}	0.1 Ω 1% 1 W	VISHAY	WSL2512R1000FEA
1	R _T	35.7 kΩ 1%	VISHAY	CRCW080535K7FKEA
1	R _{UV1}	1.82 kΩ 1%	VISHAY	CRCW08051K82FKEA
1	R _{UV2}	10 kΩ 1%	VISHAY	CRCW080510KFKEA
1	R _{UVH}	17.8 kΩ 1%	VISHAY	CRCW080517K8FKEA

8.2.4 Buck-Boost Analog Dimming Application - 4 LEDs at 2A

Figure 32. Buck-Boost Analog Dimming Application - 4 LEDs at 2 A Schematic
8.2.4.1 Detailed Design Procedure
Table 3. Bill of Materials

QTY	PART ID	PART VALUE	MANUFACTURER	PART NUMBER
1	LM3429	Boost controller	TI	LM3429MH
1	C _{COMP}	1 μ F X7R 10% 10 V	MURATA	GRM21BR71A105KA01L
1	C _F	2.2 μ F X7R 10% 16 V	MURATA	GRM21BR71C225KA12L
1	C _{FS}	0.1 μ F X7R 10% 50 V	MURATA	GRM21BR71E104KA01L
2, 1	C _{IN} , C _O	6.8 μ F X7R 10% 50 V	TDK	C4532X7R1H685K
1	C _{OV}	47 pF COG/NPO 5% 50 V	AVX	08055A470JAT2A
1	C _T	1000 pF COG/NPO 5% 50 V	MURATA	GRM2165C1H102JA01D
1	D1	Schottky 60 V 5 A	VISHAY	CDBC560-G
1	L1	22 μ H 20% 7.2 A	COILCRAFT	MSS1278-223MLB
1	Q1	NMOS 60 V 8 A	VISHAY	SI4436DY
1	Q2	PNP 150 V 600 mA	FAIRCHILD	MMBT5401
1	R _{ADJ}	1-M Ω potentiometer	BOURNS	3352P-1-105
1	R _{CSH}	12.4 k Ω 1%	VISHAY	CRCW080512K4FKEA
1	R _{FS}	10 Ω 1%	VISHAY	CRCW080510R0FKEA
2	R _{HSP} , R _{HSN}	1 k Ω 1%	VISHAY	CRCW08051K00FKEA
1	R _{LIM}	0.04 Ω 1% 1 W	VISHAY	WSL2512R0400FEA
1	R _{OV1}	18.2 k Ω 1%	VISHAY	CRCW080518K2FKEA
1	R _{OV2}	499 k Ω 1%	VISHAY	CRCW0805499KFEA
1	R _{SNS}	0.05 Ω 1% 1 W	VISHAY	WSL2512R0500FEA
1	R _T	41.2 k Ω 1%	VISHAY	CRCW080541K2FKEA

Table 3. Bill of Materials (continued)

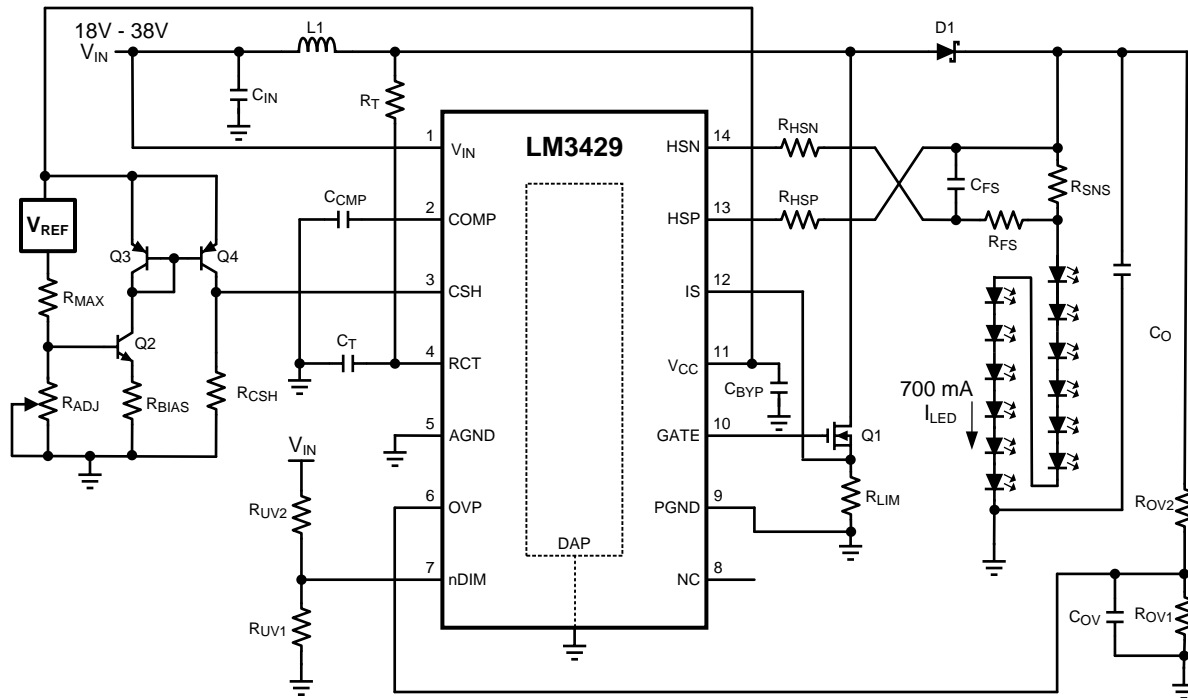
QTY	PART ID	PART VALUE	MANUFACTURER	PART NUMBER
1	R _{UV1}	21 kΩ 1%	VISHAY	CRCW080521K0FKEA
1	R _{UV2}	150 kΩ 1%	VISHAY	CRCW0805150KFKEA

8.2.5 Boost Analog Dimming Application - 12 LEDs at 700 mA

Figure 33. Boost Analog Dimming Application - 12 LEDs at 700 mA Schematic
8.2.5.1 Detailed Design Procedure
Table 4. Bill of Materials

QTY	PART ID	PART VALUE	MANUFACTURER	PART NUMBER
1	LM3429	Boost controller	TI	LM3429MH
1	C _{COMP}	1 μF X7R 10% 10 V	MURATA	GRM21BR71A105KA01L
1	C _F	2.2 μF X7R 10% 16 V	MURATA	GRM21BR71C225KA12L
1	C _{F_S}	0.1 μF X7R 10% 50 V	MURATA	GRM21BR71E104KA01L
2, 1	C _{IN} , C _O	6.8 μF X7R 10% 50 V	TDK	C4532X7R1H685K
1	C _{OV}	47 pF COG/NPO 5% 50 V	AVX	08055A470JAT2A
1	C _T	1000 pF COG/NPO 5% 50 V	MURATA	GRM2165C1H102JA01D
1	D1	Schottky 100 V 12 A	VISHAY	12CWQ10FNPNBF
1	L1	47 μH 20% 5.3 A	COILCRAFT	MSS1278-473MLB
1	Q1	NMOS 100 V 32 A	FAIRCHILD	FDD3682
1	Q2	NPN 40 V 200 mA	FAIRCHILD	MMBT3904
1	Q3, Q4 (dual pack)	Dual PNP 40 V 200 mA	FAIRCHILD	FFB3906
1	R _{ADJ}	100 kΩ potentiometer	BOURNS	3352P-1-104
1	R _{BIAS}	40.2 kΩ 1%	VISHAY	CRCW080540K2FKEA
1	R _{CSH} , R _{OV1} , R _{UV1}	12.4 kΩ 1%	VISHAY	CRCW080512K4FKEA
1	R _{FS}	10 Ω 1%	VISHAY	CRCW080510R0FKEA
2	R _{HSP} , R _{HSN}	1.05 kΩ 1%	VISHAY	CRCW08051K05FKEA
1	R _{LIM}	0.06 Ω 1% 1 W	VISHAY	WSL2512R0600FEA
1	R _{MAX}	4.99 kΩ 1%	VISHAY	CRCW08054K99FKEA
1	R _{OV2}	499 kΩ 1%	VISHAY	CRCW0805499KFEA
1	R _{SNS}	0.15 Ω 1% 1 W	VISHAY	WSL2512R1500FEA

Table 4. Bill of Materials (continued)

QTY	PART ID	PART VALUE	MANUFACTURER	PART NUMBER
1	R _T	35.7 kΩ 1%	VISHAY	CRCW080535K7FKEA
1	R _{UV2}	100 kΩ 1%	VISHAY	CRCW0805100KFKEA
1	V _{REF}	5 V precision reference	TI	LM4040

LM3429, LM3429-Q1

SNVS616H – APRIL 2009 – REVISED JULY 2015

www.ti.com

8.2.6 Buck-Boost PWM Dimming Application - 6 LEDs at 500 mA

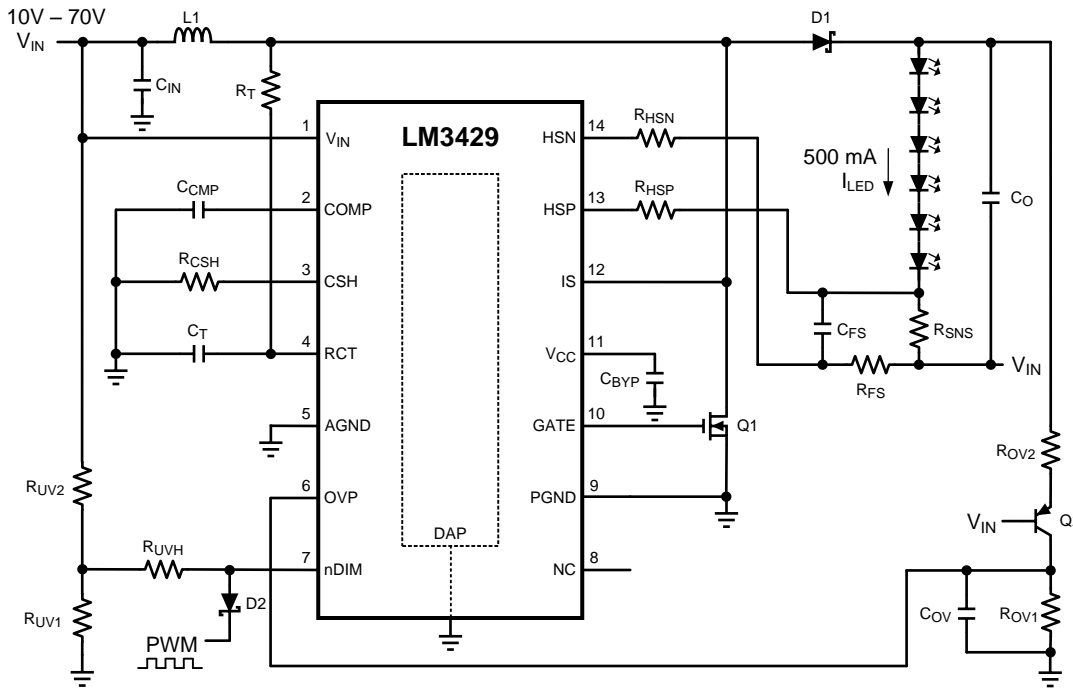

Figure 34. Buck-Boost PWM Dimming Application - 6 LEDs at 500 mA

8.2.6.1 Detailed Design Procedure

Table 5. Bill of Materials

QTY	PART ID	PART VALUE	MANUFACTURER	PART NUMBER
1	LM3429	Boost controller	TI	LM3429MH
1	C _{COMP}	0.68 μ F X7R 10% 25 V	MURATA	GRM21BR71E684KA88L
1	C _F	2.2 μ F X7R 10% 16 V	MURATA	GRM21BR71C225KA12L
1	C _{FS}	0.1 μ F X7R 10% 25 V	MURATA	GRM21BR71E104KA01L
3	C _{IN}	4.7 μ F X7R 10% 100 V	TDK	C5750X7R2A475K
1	C _O	6.8 μ F X7R 10% 50 V	TDK	C4532X7R1H685K
1	C _{OV}	47 pF COG/NPO 5% 50 V	AVX	08055A470JAT2A
1	C _T	1000 pF COG/NPO 5% 50 V	MURATA	GRM2165C1H102JA01D
1	D1	Schottky 100 V 12 A	VISHAY	12CWQ10FNPBF
1	D2	Schottky 30 V 500 mA	ON SEMI	BAT54T1G
1	L1	68 μ H 20% 4.3 A	COILCRAFT	MSS1278-683MLB
1	Q1	NMOS 100 V 32 A	VISHAY	FDD3682
1	Q2	PNP 150 V 600 mA	FAIRCHILD	MMBT5401
1	R _{CSH}	12.4 k Ω 1%	VISHAY	CRCW080512K4FKEA
1	R _{FS}	10 Ω 1%	VISHAY	CRCW080510R0FKEA
2	R _{HSP} , R _{HSN}	1 k Ω 1%	VISHAY	CRCW08051K00FKEA
1	R _{OV1}	15.8 k Ω 1%	VISHAY	CRCW080515K8FKEA
1	R _{OV2}	499 k Ω 1%	VISHAY	CRCW0805499KFKEA
1	R _{SNS}	0.2 Ω 1% 1 W	VISHAY	WSL2512R2000FEA
1	R _T	35.7 k Ω 1%	VISHAY	CRCW080535K7FKEA
1	R _{UV1}	1.43 k Ω 1%	VISHAY	CRCW08051K43FKEA
1	R _{UV2}	10 k Ω 1%	VISHAY	CRCW080510K0FKEA

Table 5. Bill of Materials (continued)

QTY	PART ID	PART VALUE	MANUFACTURER	PART NUMBER
1	RUVH	17.4 kΩ 1%	VISHAY	CRCW080517K4FKEA

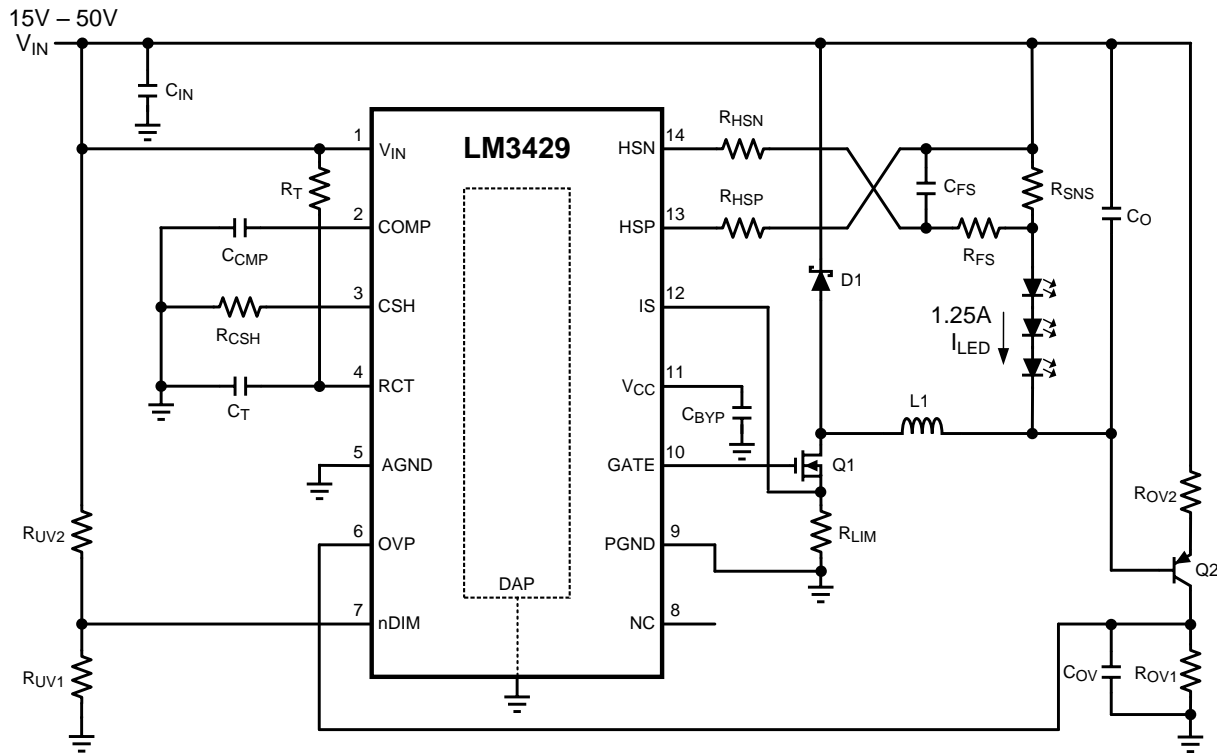
8.2.7 Buck Application - 3 LEDs at 1.25 A

Figure 35. Buck Application - 3 LEDs at 1.25 A Schematic
8.2.7.1 Detailed Design Procedure
Table 6. Bill of Materials

QTY	PART ID	PART VALUE	MANUFACTURER	PART NUMBER
1	LM3429	Boost controller	TI	LM3429MH
1	CCMP	0.015 μ F X7R 10% 50 V	MURATA	GRM21BR71H153KA01L
1	CF	2.2 μ F X7R 10% 16 V	MURATA	GRM21BR71C225KA12L
1	CFS	0.01 μ F X7R 10% 50 V	MURATA	GRM21BR71H103KA01L
2	CIN	6.8 μ F X7R 10% 50 V	TDK	C4532X7R1H685K
1	CO	1 μ F X7R 10% 50 V	TDK	C4532X7R1H105K
1	COV	47 pF COG/NPO 5% 50 V	AVX	08055A470JAT2A
1	CT	1000 pF COG/NPO 5% 50 V	MURATA	GRM2165C1H102JA01D
1	D1	Schottky 60V 5 A	COMCHIP	CDBC560-G
1	L1	22 μ H 20% 7.3 A	COILCRAFT	MSS1278-223MLB
1	Q1	NMOS 60 V 8 A	VISHAY	SI4436DY
1	Q2	PNP 150 V 600 mA	FAIRCHILD	MMBT5401
1	RCSH	12.4 k Ω 1%	VISHAY	CRCW080512K4FKEA
1	RT	49.9 k Ω 1%	VISHAY	CRCW080549K9FKEA
1	RFS	10 Ω 1%	VISHAY	CRCW080510R0FKEA
2	RHSP, RHSN	1 k Ω 1%	VISHAY	CRCW08051K00FKEA
1	RLIM	0.04 Ω 1% 1 W	VISHAY	WSL2512R0400FEA
1	ROV1	21.5 k Ω 1%	VISHAY	CRCW080521K5FKEA
1	ROV2	499 k Ω 1%	VISHAY	CRCW0805499KFKEA
1	RSNS	0.08 Ω 1% 1 W	VISHAY	WSL2512R0800FEA

Table 6. Bill of Materials (continued)

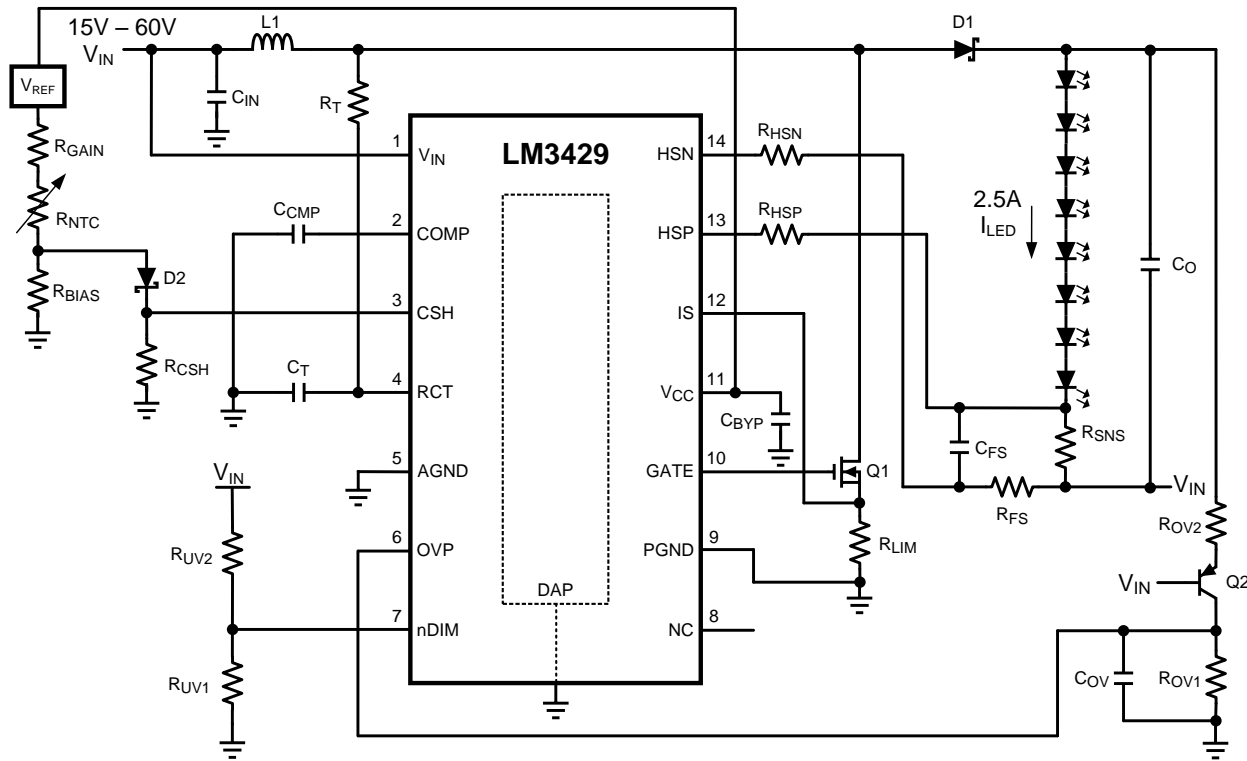
QTY	PART ID	PART VALUE	MANUFACTURER	PART NUMBER
1	R _{UV1}	11.5 kΩ 1%	VISHAY	CRCW080511K5FKEA
1	R _{UV2}	100 kΩ 1%	VISHAY	CRCW0805100KFKEA

8.2.8 Buck-Boost Thermal Foldback Application - 8 LEDs at 2.5 A

Figure 36. Buck-Boost Thermal Foldback Application - 8 LEDs at 2.5 A Schematic
8.2.8.1 Detailed Design Procedure
Table 7. Bill of Materials

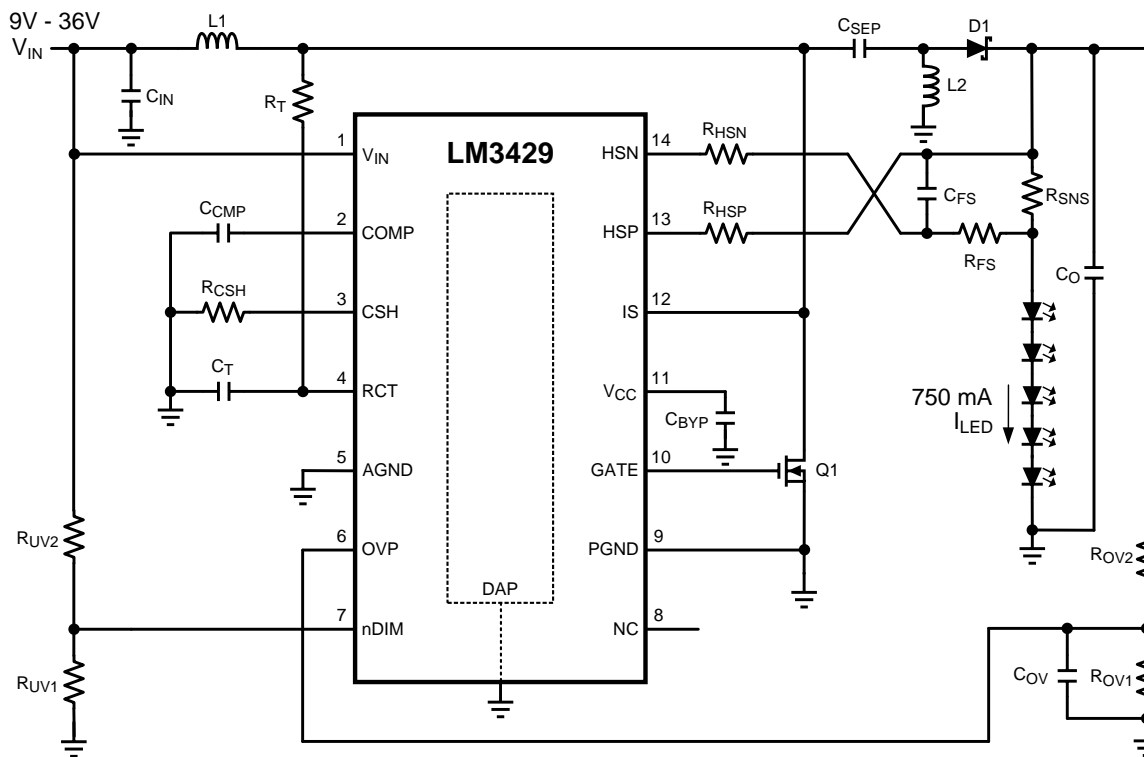
QTY	PART ID	PART VALUE	MANUFACTURER	PART NUMBER
1	LM3429	Boost controller	TI	LM3429MH
1	CCMP	0.1 μ F X7R 10% 25 V	MURATA	GRM21BR71E104KA01L
1	CF	2.2 μ F X7R 10% 16 V	MURATA	GRM21BR71C225KA12L
1	CFS	0.1 μ F X7R 10% 25 V	MURATA	GRM21BR71E104KA01L
3	CIN	4.7 μ F X7R 10% 100 V	TDK	C5750X7R2A475K
1	CO	6.8 μ F X7R 10% 50 V	TDK	C4532X7R1H685K
1	COV	47 pF COG/NPO 5% 50 V	AVX	08055A470JAT2A
1	CT	1000 pF COG/NPO 5% 50 V	MURATA	GRM2165C1H102JA01D
1	D1	Schottky 100 V 12 A	VISHAY	12CWQ10FNPBF
1	L1	22 μ H 20% 7.2 A	COILCRAFT	MSS1278-223MLB
1	Q1	NMOS 100 V 32 A	FAIRCHILD	FDD3682
1	Q2	PNP 150 V 600 mA	FAIRCHILD	MMBT5401
2	RCSH, ROV1	12.4 k Ω 1%	VISHAY	CRCW080512K4FKEA
1	RFS	10 Ω 1%	VISHAY	CRCW080510R0FKEA
2	RHSP, RLSN	1 k Ω 1%	VISHAY	CRCW08051K00FKEA
2	RLIM, RSNS	0.04 Ω 1% 1 W	VISHAY	WSL2512R0400FEA
1	ROV2	499 k Ω 1%	VISHAY	CRCW0805499KFKEA
1	RT	49.9 k Ω 1%	VISHAY	CRCW080549K9FKEA
1	RUV1	13.7 k Ω 1%	VISHAY	CRCW080513K7FKEA
1	RUV2	150 k Ω 1%	VISHAY	CRCW0805150KFKEA

8.2.9 SEPIC Application - 5 LEDs at 750 mA

Figure 37. 5 LEDs at 750 mA
8.2.9.1 Detailed Design Procedure
Table 8. Bill of Materials

QTY	PART ID	PART VALUE	MANUFACTURER	PART NUMBER
1	LM3429	Boost controller	TI	LM3429MH
1	CCMP	0.47 μ F X7R 10% 25 V	MURATA	GRM21BR71E474KA01L
1	CF	2.2 μ F X7R 10% 16 V	MURATA	GRM21BR71C225KA12L
1	CFS	0.1 μ F X7R 10% 25 V	MURATA	GRM21BR71E104KA01L
2, 1	CIN, CO	6.8 μ F X7R 10% 50 V	TDK	C4532X7R1H685K
1	COV	47 pF COG/NPO 5% 50 V	AVX	08055A470JAT2A
1	CSEP	1 μ F X7R 10% 100 V	TDK	C4532X7R2A105K
1	CT	1000 pF COG/NPO 5% 50 V	MURATA	GRM2165C1H102JA01D
1	D1	Schottky 60 V 5 A	COMCHIP	CDBC560-G
1	L1, L2	68 μ H 20% 4.3 A	COILCRAFT	DO3340P-683
1	Q1	NMOS 60 V 8 A	VISHAY	SI4436DY
1	Q2	NMOS 60 V 115 mA	ON SEMI	2N7002ET1G
1	RCSH	12.4 k Ω 1%	VISHAY	CRCW080512K4FKEA
1	RFS	10 Ω 1%	VISHAY	CRCW080510R0FKEA
2	RHSP, RHSN	750 Ω 1%	VISHAY	CRCW0805750RFKEA
1	RLIM	0.04 Ω 1% 1 W	VISHAY	WSL2512R0400FEA
2	ROV1, RUV1	15.8 k Ω 1%	VISHAY	CRCW080515K8FKEA
1	ROV2	499 k Ω 1%	VISHAY	CRCW0805499KFKEA
1	RSNS	0.1 Ω 1% 1 W	VISHAY	WSL2512R1000FEA
1	RT	49.9 k Ω 1%	VISHAY	CRCW080549K9FKEA

Table 8. Bill of Materials (continued)

QTY	PART ID	PART VALUE	MANUFACTURER	PART NUMBER
1	R _{UV2}	100 k Ω 1%	VISHAY	CRCW0805100KFKEA

9 Power Supply Recommendations

The device is designed to operate from an input voltage supply range from 4.5 V to 75 V. This input supply should be well regulated. If the input supply is located more than a few inches from the EVM or PCB, additional bulk capacitance may be required in addition to the ceramic bypass capacitors.

9.1 Input Supply Current Limit

It is important to set the output current limit of your input supply to an appropriate value to avoid delays in your converter analysis and optimization. If not set high enough, current limit can be tripped during start-up or when your converter output power is increased, causing a foldback or shut-down condition. It is a common oversight when powering up a converter for the first time.

10 Layout

10.1 Layout Guidelines

The performance of any switching regulator depends as much upon the layout of the PCB as the component selection. Following a few simple guidelines will maximize noise rejection and minimize the generation of EMI within the circuit.

Discontinuous currents are the most likely to generate EMI; therefore, take care when routing these paths. The main path for discontinuous current in the LM3429 buck regulator contains the input capacitor (C_{IN}), the recirculating diode (D1), the N-channel MosFET (Q1), and the switch sense resistor (R_{LIM}). In the LM3429 boost and buck-boost regulators, the discontinuous current flows through the output capacitor (C_O), D1, Q1, and R_{LIM} . In either case, this loop should be kept as small as possible and the connections between all the components should be short and thick to minimize parasitic inductance. In particular, the switch node (where L1, D1 and Q1 connect) should be just large enough to connect the components. To minimize excessive heating, large copper pours can be placed adjacent to the short current path of the switch node.

The RCT, COMP, CSH, IS, HSP and HSN pins are all high-impedance inputs which couple external noise easily, therefore the loops containing these nodes should be minimized whenever possible.

In some applications the LED or LED array can be far away (several inches or more) from the LM3429, or on a separate PCB connected by a wiring harness. When an output capacitor is used and the LED array is large or separated from the rest of the regulator, the output capacitor should be placed close to the LEDs to reduce the effects of parasitic inductance on the AC impedance of the capacitor.

10.2 Layout Example

Note critical paths and component placement:

- Minimize power loop containing discontinuous currents
- Minimize signal current loops (components close to IC)
- Ground plane under IC for signal routing helps minimize noise coupling

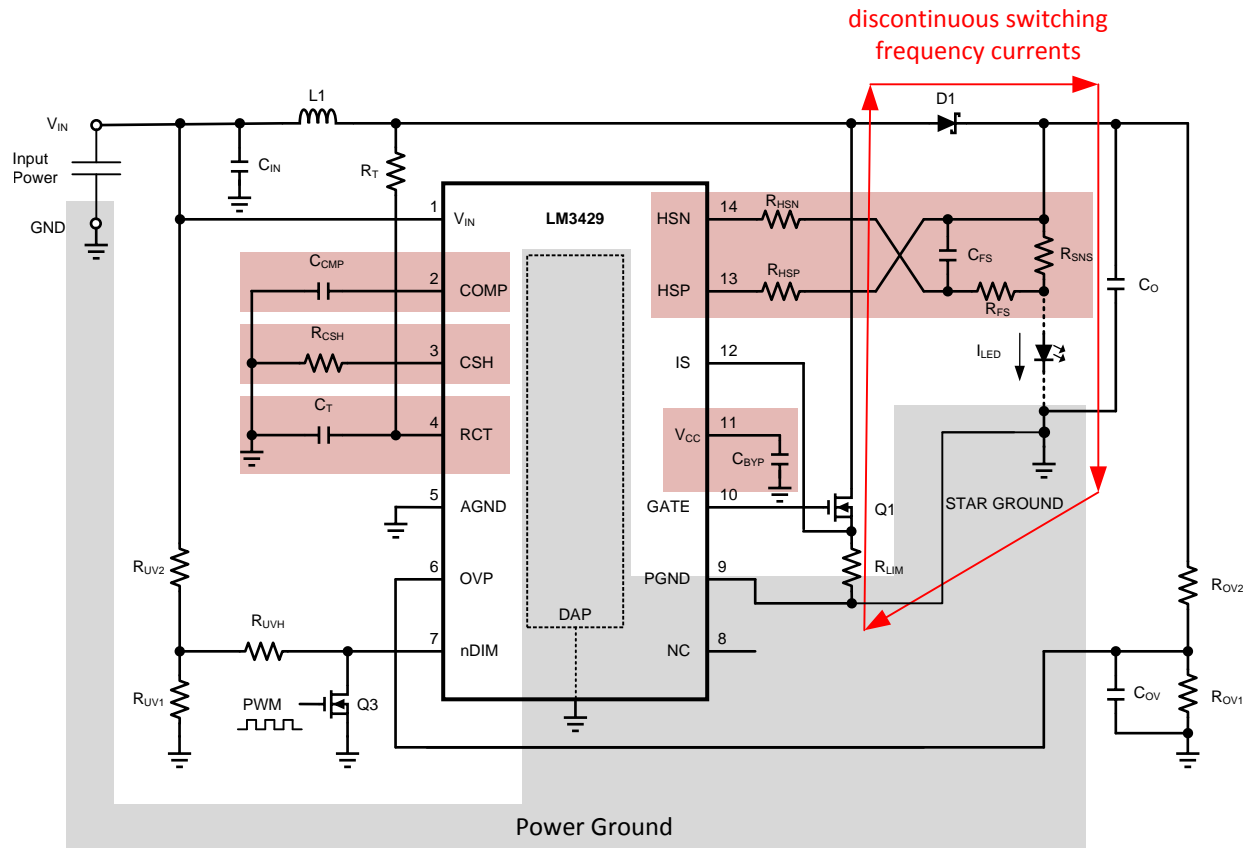

Figure 38. LM3429 Layout Guideline

11 Device and Documentation Support

11.1 Device Support

11.1.1 Third-Party Products Disclaimer

TI'S PUBLICATION OF INFORMATION REGARDING THIRD-PARTY PRODUCTS OR SERVICES DOES NOT CONSTITUTE AN ENDORSEMENT REGARDING THE SUITABILITY OF SUCH PRODUCTS OR SERVICES OR A WARRANTY, REPRESENTATION OR ENDORSEMENT OF SUCH PRODUCTS OR SERVICES, EITHER ALONE OR IN COMBINATION WITH ANY TI PRODUCT OR SERVICE.

11.2 Documentation Support

11.2.1 Related Documentation

For related documentation see the following:

- *AN-1986 LM3429 Boost Evaluation Board*, [SNVA404](#)
- *AN-1985 LM3429 Buck-Boost Evaluation Board*, [SNVA403](#)

11.3 Related Links

The table below lists quick access links. Categories include technical documents, support and community resources, tools and software, and quick access to sample or buy.

Table 9. Related Links

PARTS	PRODUCT FOLDER	SAMPLE & BUY	TECHNICAL DOCUMENTS	TOOLS & SOFTWARE	SUPPORT & COMMUNITY
LM3429	Click here	Click here	Click here	Click here	Click here
LM3429-Q1	Click here	Click here	Click here	Click here	Click here

11.4 Community Resources

The following links connect to TI community resources. Linked contents are provided "AS IS" by the respective contributors. They do not constitute TI specifications and do not necessarily reflect TI's views; see TI's [Terms of Use](#).

TI E2E™ Online Community *TI's Engineer-to-Engineer (E2E) Community*. Created to foster collaboration among engineers. At e2e.ti.com, you can ask questions, share knowledge, explore ideas and help solve problems with fellow engineers.

Design Support *TI's Design Support* Quickly find helpful E2E forums along with design support tools and contact information for technical support.

The following links connect to TI community resources. Linked contents are provided "AS IS" by the respective contributors. They do not constitute TI specifications and do not necessarily reflect TI's views; see TI's [Terms of Use](#).

TI E2E™ Online Community *TI's Engineer-to-Engineer (E2E) Community*. Created to foster collaboration among engineers. At e2e.ti.com, you can ask questions, share knowledge, explore ideas and help solve problems with fellow engineers.

Design Support *TI's Design Support* Quickly find helpful E2E forums along with design support tools and contact information for technical support.

11.5 Trademarks

E2E is a trademark of Texas Instruments.

All other trademarks are the property of their respective owners.

11.6 Electrostatic Discharge Caution



These devices have limited built-in ESD protection. The leads should be shorted together or the device placed in conductive foam during storage or handling to prevent electrostatic damage to the MOS gates.

11.7 Glossary

[SLYZ022](#) — *TI Glossary*.

This glossary lists and explains terms, acronyms, and definitions.

12 Mechanical, Packaging, and Orderable Information

The following pages include mechanical, packaging, and orderable information. This information is the most current data available for the designated devices. This data is subject to change without notice and revision of this document. For browser-based versions of this data sheet, refer to the left-hand navigation.

PACKAGING INFORMATION

Orderable Device	Status (1)	Package Type	Package Drawing	Pins	Package Qty	Eco Plan (2)	Lead finish/ Ball material (6)	MSL Peak Temp (3)	Op Temp (°C)	Device Marking (4/5)	Samples
LM3429MH/NOPB	ACTIVE	HTSSOP	PWP	14	94	RoHS & Green	Call TI SN	Level-1-260C-UNLIM	-40 to 125	LM3429 MH	Samples
LM3429MHX/NOPB	ACTIVE	HTSSOP	PWP	14	2500	RoHS & Green	Call TI SN	Level-1-260C-UNLIM	-40 to 125	LM3429 MH	Samples
LM3429Q1MH/NOPB	ACTIVE	HTSSOP	PWP	14	94	RoHS & Green	Call TI SN	Level-1-260C-UNLIM	-40 to 125	LM3429 Q1MH	Samples
LM3429Q1MHX/NOPB	ACTIVE	HTSSOP	PWP	14	2500	RoHS & Green	Call TI SN	Level-1-260C-UNLIM	-40 to 125	LM3429 Q1MH	Samples

(1) The marketing status values are defined as follows:

ACTIVE: Product device recommended for new designs.

LIFEBUY: TI has announced that the device will be discontinued, and a lifetime-buy period is in effect.

NRND: Not recommended for new designs. Device is in production to support existing customers, but TI does not recommend using this part in a new design.

PREVIEW: Device has been announced but is not in production. Samples may or may not be available.

OBSELETE: TI has discontinued the production of the device.

(2) **RoHS:** TI defines "RoHS" to mean semiconductor products that are compliant with the current EU RoHS requirements for all 10 RoHS substances, including the requirement that RoHS substance do not exceed 0.1% by weight in homogeneous materials. Where designed to be soldered at high temperatures, "RoHS" products are suitable for use in specified lead-free processes. TI may reference these types of products as "Pb-Free".

RoHS Exempt: TI defines "RoHS Exempt" to mean products that contain lead but are compliant with EU RoHS pursuant to a specific EU RoHS exemption.

Green: TI defines "Green" to mean the content of Chlorine (Cl) and Bromine (Br) based flame retardants meet JS709B low halogen requirements of <=1000ppm threshold. Antimony trioxide based flame retardants must also meet the <=1000ppm threshold requirement.

(3) MSL, Peak Temp. - The Moisture Sensitivity Level rating according to the JEDEC industry standard classifications, and peak solder temperature.

(4) There may be additional marking, which relates to the logo, the lot trace code information, or the environmental category on the device.

(5) Multiple Device Markings will be inside parentheses. Only one Device Marking contained in parentheses and separated by a "~" will appear on a device. If a line is indented then it is a continuation of the previous line and the two combined represent the entire Device Marking for that device.

(6) Lead finish/Ball material - Orderable Devices may have multiple material finish options. Finish options are separated by a vertical ruled line. Lead finish/Ball material values may wrap to two lines if the finish value exceeds the maximum column width.

Important Information and Disclaimer:The information provided on this page represents TI's knowledge and belief as of the date that it is provided. TI bases its knowledge and belief on information provided by third parties, and makes no representation or warranty as to the accuracy of such information. Efforts are underway to better integrate information from third parties. TI has taken and

continues to take reasonable steps to provide representative and accurate information but may not have conducted destructive testing or chemical analysis on incoming materials and chemicals. TI and TI suppliers consider certain information to be proprietary, and thus CAS numbers and other limited information may not be available for release.

In no event shall TI's liability arising out of such information exceed the total purchase price of the TI part(s) at issue in this document sold by TI to Customer on an annual basis.

OTHER QUALIFIED VERSIONS OF LM3429, LM3429-Q1 :

- Catalog : [LM3429](#)
- Automotive : [LM3429-Q1](#)

NOTE: Qualified Version Definitions:

- Catalog - TI's standard catalog product
- Automotive - Q100 devices qualified for high-reliability automotive applications targeting zero defects

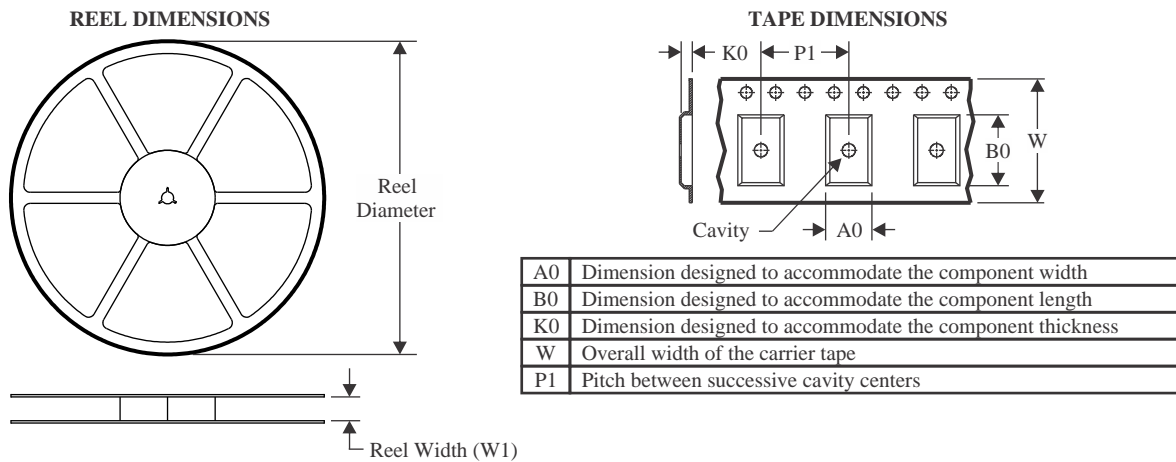
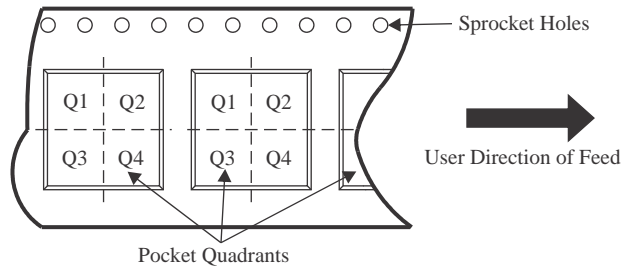
TAPE AND REEL INFORMATION

QUADRANT ASSIGNMENTS FOR PIN 1 ORIENTATION IN TAPE

*All dimensions are nominal

Device	Package Type	Package Drawing	Pins	SPQ	Reel Diameter (mm)	Reel Width W1 (mm)	A0 (mm)	B0 (mm)	K0 (mm)	P1 (mm)	W (mm)	Pin1 Quadrant
LM3429MHX/NOPB	HTSSOP	PWP	14	2500	330.0	12.4	6.95	5.6	1.6	8.0	12.0	Q1
LM3429Q1MHX/NOPB	HTSSOP	PWP	14	2500	330.0	12.4	6.95	5.6	1.6	8.0	12.0	Q1

TAPE AND REEL BOX DIMENSIONS

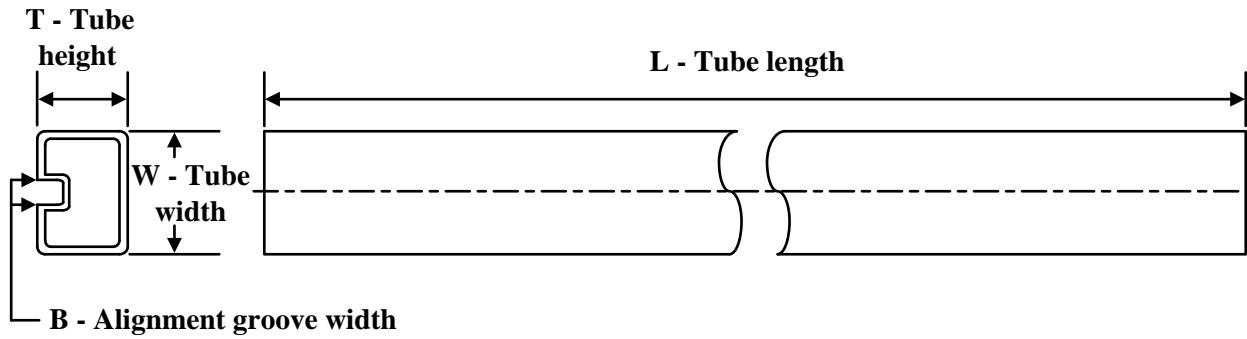

*All dimensions are nominal

Device	Package Type	Package Drawing	Pins	SPQ	Length (mm)	Width (mm)	Height (mm)
LM3429MHX/NOPB	HTSSOP	PWP	14	2500	367.0	367.0	35.0
LM3429Q1MHX/NOPB	HTSSOP	PWP	14	2500	367.0	367.0	35.0

TUBE

*All dimensions are nominal

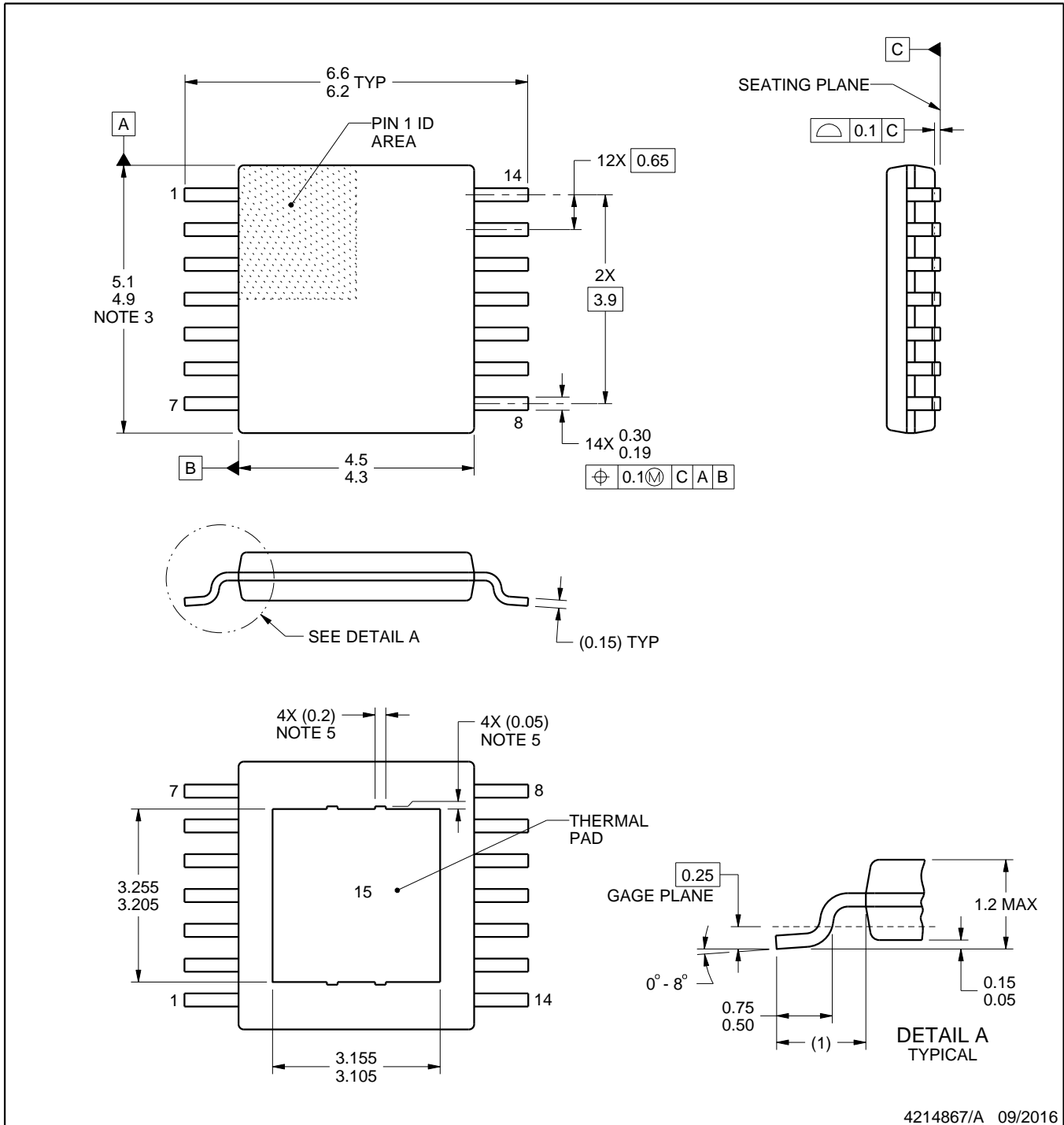
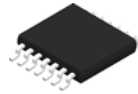
Device	Package Name	Package Type	Pins	SPQ	L (mm)	W (mm)	T (μm)	B (mm)
LM3429MH/NOPB	PWP	HTSSOP	14	94	495	8	2514.6	4.06
LM3429Q1MH/NOPB	PWP	HTSSOP	14	94	495	8	2514.6	4.06
LM3429Q1MH/NOPB	PWP	HTSSOP	14	94	495	8	2514.6	4.06



4214867/A 09/2016

NOTES:

PowerPAD is a trademark of Texas Instruments.

1. All linear dimensions are in millimeters. Any dimensions in parenthesis are for reference only. Dimensioning and tolerancing per ASME Y14.5M.
2. This drawing is subject to change without notice.
3. This dimension does not include mold flash, protrusions, or gate burrs. Mold flash, protrusions, or gate burrs shall not exceed 0.15 mm per side.
4. Reference JEDEC registration MO-153.
5. Features may differ and may not be present.

EXAMPLE STENCIL DESIGN

PWP0014A

PowerPAD™ TSSOP - 1.2 mm max height

PLASTIC SMALL OUTLINE

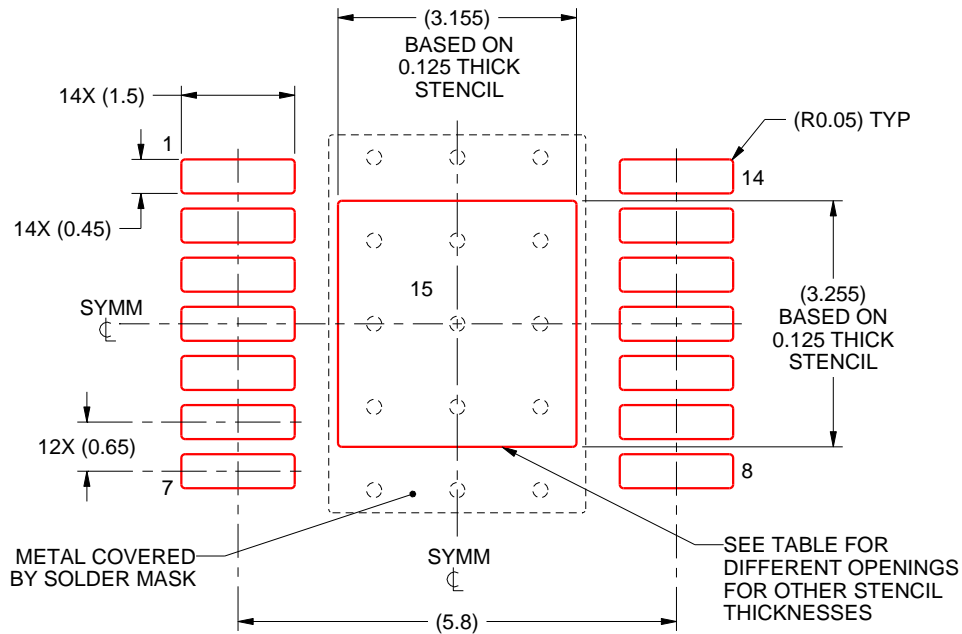

SOLDER PASTE EXAMPLE
 EXPOSED PAD
 100% PRINTED SOLDER COVERAGE BY AREA
 SCALE:10X

STENCIL THICKNESS	SOLDER STENCIL OPENING
0.1	3.53 X 3.64
0.125	3.155 X 3.255 (SHOWN)
0.15	2.88 X 2.97
0.175	2.67 X 2.75

4214867/A 09/2016

NOTES: (continued)

10. Laser cutting apertures with trapezoidal walls and rounded corners may offer better paste release. IPC-7525 may have alternate design recommendations.
11. Board assembly site may have different recommendations for stencil design.

IMPORTANT NOTICE AND DISCLAIMER

TI PROVIDES TECHNICAL AND RELIABILITY DATA (INCLUDING DATA SHEETS), DESIGN RESOURCES (INCLUDING REFERENCE DESIGNS), APPLICATION OR OTHER DESIGN ADVICE, WEB TOOLS, SAFETY INFORMATION, AND OTHER RESOURCES "AS IS" AND WITH ALL FAULTS, AND DISCLAIMS ALL WARRANTIES, EXPRESS AND IMPLIED, INCLUDING WITHOUT LIMITATION ANY IMPLIED WARRANTIES OF MERCHANTABILITY, FITNESS FOR A PARTICULAR PURPOSE OR NON-INFRINGEMENT OF THIRD PARTY INTELLECTUAL PROPERTY RIGHTS.

These resources are intended for skilled developers designing with TI products. You are solely responsible for (1) selecting the appropriate TI products for your application, (2) designing, validating and testing your application, and (3) ensuring your application meets applicable standards, and any other safety, security, regulatory or other requirements.

These resources are subject to change without notice. TI grants you permission to use these resources only for development of an application that uses the TI products described in the resource. Other reproduction and display of these resources is prohibited. No license is granted to any other TI intellectual property right or to any third party intellectual property right. TI disclaims responsibility for, and you will fully indemnify TI and its representatives against, any claims, damages, costs, losses, and liabilities arising out of your use of these resources.

TI's products are provided subject to [TI's Terms of Sale](#) or other applicable terms available either on [ti.com](https://www.ti.com) or provided in conjunction with such TI products. TI's provision of these resources does not expand or otherwise alter TI's applicable warranties or warranty disclaimers for TI products.

TI objects to and rejects any additional or different terms you may have proposed.

Mailing Address: Texas Instruments, Post Office Box 655303, Dallas, Texas 75265
Copyright © 2023, Texas Instruments Incorporated

Looking for pricing, stock, or lifecycle information?

Click below to explore more details on WIN SOURCE:

 [View LM3429Q1MHX/NOPB on WIN SOURCE](#)

 [Texas Instruments](#) Information

Optimize Your Supply Chain with WIN SOURCE Solutions

-  Global Sourcing Solution
-  Obsolete Management
-  Cost Control Management
-  Shortage Management
-  Alternative Solution
-  Excess Inventory Management