



# THE DATASHEET OF LM2903SNG



# LM393S, LM2903S

## Low Offset Voltage Dual Comparators

The LM393S and LM2903S are dual, independent, precision voltage comparators capable of single or split supply operation. These devices are designed to permit a common mode range to ground level with single supply operation. Input offset voltage specifications as low as 2.0 mV make this device an excellent selection for many applications in consumer, automotive, and industrial electronics.

### Features

- Wide Single-Supply Range: 2.0 Vdc to 36 Vdc
- Split-Supply Range:  $\pm 1.0$  Vdc to  $\pm 18$  Vdc
- Very Low Current Drain Independent of Supply Voltage: 0.4 mA
- Low Input Bias Current: 25 nA
- Low Input Offset Current: 5.0 nA
- Low Input Offset Voltage: 5.0 mV (max) with LM393S
- Input Common Mode Range to Ground Level
- Differential Input Voltage Range Equal to Power Supply Voltage
- Output Voltage Compatible with DTL, ECL, TTL, MOS, and CMOS Logic Levels
- These Devices are Pb-Free, Halogen Free/BFR Free and are RoHS Compliant

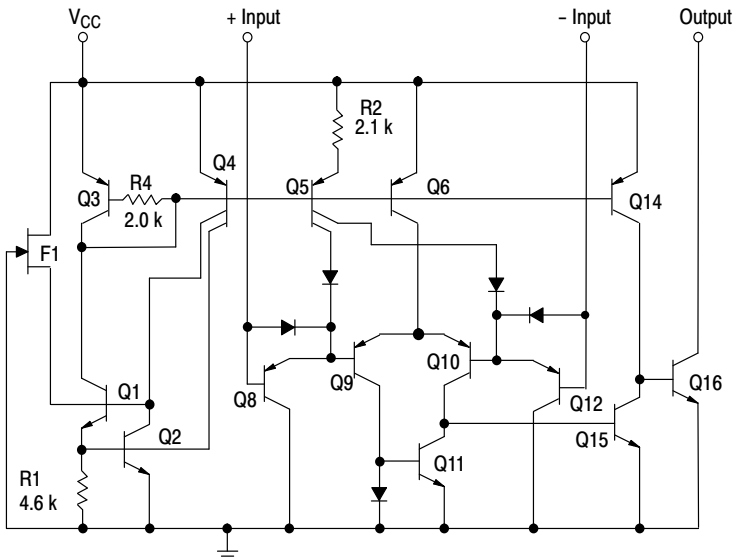

**Figure 1. Representative Schematic Diagram**  
(Diagram shown is for 1 comparator)



**ON Semiconductor®**

<http://onsemi.com>

### MARKING DIAGRAMS

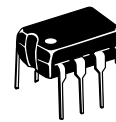

**PDIP-8  
N SUFFIX  
CASE 626**

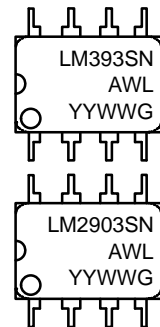

LMxxxx = Specific Device Code  
A, AL = Assembly Location  
WL = Wafer Lot  
Y, YY = Year  
W, WW = Work Week  
G or ■ = Pb-Free Package

### PIN CONNECTIONS

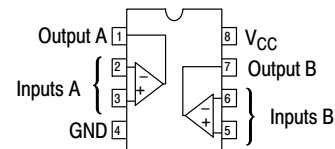

(Top View)

### ORDERING INFORMATION

See detailed marking information and ordering and shipping information on page 7 of this data sheet.

# LM393S, LM2903S

## MAXIMUM RATINGS

Rating	Symbol	Value	Unit
Power Supply Voltage	$V_{CC}$	+36 or $\pm 18$	V
Input Differential Voltage	$V_{IDR}$	36	V
Input Common Mode Voltage Range (Note 1)	$V_{ICR}$	-0.3 to +36	V
Output Voltage	$V_O$	36	V
Output Short Circuit-to-Ground Output Sink Current (Note 2)	$I_{SC}$ $I_{Sink}$	Continuous 20	mA
Power Dissipation @ $T_A = 25^\circ\text{C}$ Derate above $25^\circ\text{C}$	$P_D$ $1/R_{\theta JA}$	570 5.7	MW mW/ $^\circ\text{C}$
Operating Ambient Temperature Range  LM393S LM2903S	$T_A$	0 to +70 -40 to +105	$^\circ\text{C}$
Maximum Operating Junction Temperature	$T_{J(max)}$	150	$^\circ\text{C}$
Storage Temperature Range	$T_{stg}$	-65 to +150	$^\circ\text{C}$

Stresses exceeding those listed in the Maximum Ratings table may damage the device. If any of these limits are exceeded, device functionality should not be assumed, damage may occur and reliability may be affected.

1. For supply voltages less than 36 V, the absolute maximum input voltage is equal to the supply voltage.
2. The maximum output current may be as high as 20 mA, independent of the magnitude of  $V_{CC}$ , output short circuits to  $V_{CC}$  can cause excessive heating and eventual destruction.

# LM393S, LM2903S

## ELECTRICAL CHARACTERISTICS ( $V_{CC} = 5.0$ Vdc, $T_{low} \leq T_A \leq T_{high}$ , unless otherwise noted.)

Characteristic	Symbol	LM393S			LM2903S			Unit
		Min	Typ	Max	Min	Typ	Max	
Input Offset Voltage (Note 3) $T_A = 25^\circ\text{C}$ $T_{low} \leq T_A \leq T_{high}$	$V_{IO}$	–	$\pm 1.0$	$\pm 5.0$	–	$\pm 2.0$	$\pm 7.0$	mV
		–	–	$\pm 9.0$	–	$\pm 9.0$	$\pm 15$	
Input Offset Current $T_A = 25^\circ\text{C}$ $T_{low} \leq T_A \leq T_{high}$	$I_{IO}$	–	$\pm 5.0$	$\pm 50$	–	$\pm 5.0$	$\pm 50$	nA
		–	–	$\pm 150$	–	$\pm 50$	$\pm 200$	
Input Bias Current (Note 4) $T_A = 25^\circ\text{C}$ $T_{low} \leq T_A \leq T_{high}$	$I_{IB}$	–	25	250	–	25	250	nA
		–	–	400	–	200	500	
Input Common Mode Voltage Range (Note 5) $T_A = 25^\circ\text{C}$ $T_{low} \leq T_A \leq T_{high}$	$V_{ICR}$	0	–	$V_{CC} - 1.5$	0	–	$V_{CC} - 1.5$	V
		0	–	$V_{CC} - 2.0$	0	–	$V_{CC} - 2.0$	
Voltage Gain $R_L \geq 15$ k $\Omega$ , $V_{CC} = 15$ Vdc, $T_A = 25^\circ\text{C}$	$A_{VOL}$	50	200	–	25	200	–	V/mV
Large Signal Response Time $V_{in} =$ TTL Logic Swing, $V_{ref} = 1.4$ Vdc $V_{RL} = 5.0$ Vdc, $R_L = 5.1$ k $\Omega$ , $T_A = 25^\circ\text{C}$	–	–	200	–	–	200	–	ns
Response Time (Note 6) $V_{RL} = 5.0$ Vdc, $R_L = 5.1$ k $\Omega$ , $T_A = 25^\circ\text{C}$	$t_{TLH}$	–	1.0	–	–	1.0	–	$\mu\text{s}$
Input Differential Voltage (Note 7) All $V_{in} \geq$ GND or V– Supply (if used)	$V_{ID}$	–	–	$V_{CC}$	–	–	$V_{CC}$	V
Output Sink Current $V_{in} \geq 1.0$ Vdc, $V_{in+} = 0$ Vdc, $V_O \leq 1.5$ Vdc $T_A = 25^\circ\text{C}$	$I_{Sink}$	6.0	16	–	6.0	16	–	mA
Output Saturation Voltage $V_{in} \geq 1.0$ Vdc, $V_{in+} = 0$ , $I_{Sink} \leq 4.0$ mA, $T_A = 25^\circ\text{C}$ $T_{low} \leq T_A \leq T_{high}$	$V_{OL}$	–	150	400	–	–	400	mV
		–	–	700	–	200	700	
Output Leakage Current $V_{in-} = 0$ V, $V_{in+} \geq 1.0$ Vdc, $V_O = 5.0$ Vdc, $T_A = 25^\circ\text{C}$ $V_{in-} = 0$ V, $V_{in+} \geq 1.0$ Vdc, $V_O = 30$ Vdc, $T_{low} \leq T_A \leq T_{high}$	$I_{OL}$	–	0.1	–	–	0.1	–	nA
		–	–	1000	–	–	1000	
Supply Current $R_L = \infty$ Both Comparators, $T_A = 25^\circ\text{C}$ $R_L = \infty$ Both Comparators, $V_{CC} = 30$ V	$I_{CC}$	–	0.6	1.0	–	0.6	1.0	mA
		–	0.75	2.5	–	0.75	2.5	

Product parametric performance is indicated in the Electrical Characteristics for the listed test conditions, unless otherwise noted. Product performance may not be indicated by the Electrical Characteristics if operated under different conditions.

LM393S  $T_{low} = 0^\circ\text{C}$ ,  $T_{high} = +70^\circ\text{C}$

LM2903S  $T_{low} = -40^\circ\text{C}$ ,  $T_{high} = +105^\circ\text{C}$

3. At output switch point,  $V_O = 1.4$  Vdc,  $R_S = 0$   $\Omega$  with  $V_{CC}$  from 5.0 Vdc to 30 Vdc, and over the full input common mode range (0 V to  $V_{CC} = -1.5$  V).
4. Due to the PNP transistor inputs, bias current will flow out of the inputs. This current is essentially constant, independent of the output state, therefore, no loading changes will exist on the input lines.
5. Input common mode of either input should not be permitted to go more than 0.3 V negative of ground or minus supply. The upper limit of common mode range is  $V_{CC} - 1.5$  V.
6. Response time is specified with a 100 mV step and 5.0 mV of overdrive. With larger magnitudes of overdrive faster response times are obtainable.
7. The comparator will exhibit proper output state if one of the inputs becomes greater than  $V_{CC}$ , the other input must remain within the common mode range. The low input state must not be less than  $-0.3$  V of ground or minus supply.

# LM393S, LM2903S

## APPLICATIONS INFORMATION

These dual comparators feature high gain, wide bandwidth characteristics. This gives the device oscillation tendencies if the outputs are capacitively coupled to the inputs via stray capacitance. This oscillation manifests itself during output transitions ( $V_{OL}$  to  $V_{OH}$ ). To alleviate this situation, input resistors  $< 10\text{ k}\Omega$  should be used.

The addition of positive feedback ( $< 10\text{ mV}$ ) is also recommended. It is good design practice to ground all unused pins.

Differential input voltages may be larger than supply voltage without damaging the comparator's inputs. Voltages more negative than  $-0.3\text{ V}$  should not be used.

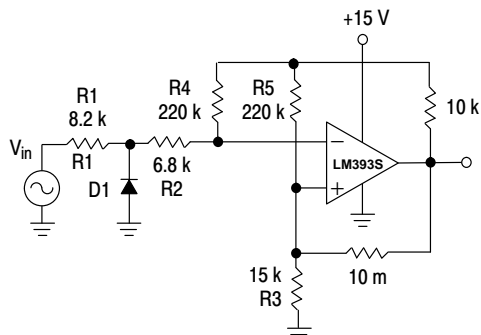

D1 prevents input from going negative by more than 0.6 V.

$$R1 + R2 = R3$$

$$R3 \leq \frac{R5}{10} \text{ for small error in zero crossing.}$$

**Figure 2. Zero Crossing Detector (Single Supply)**

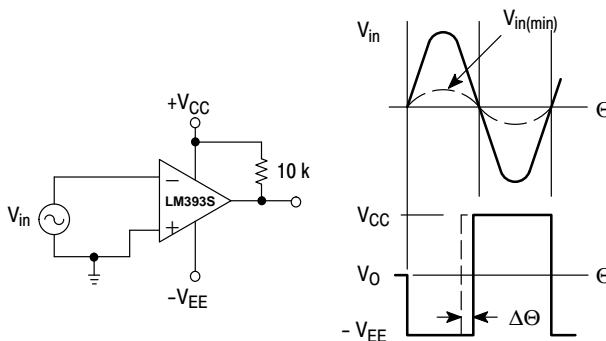

$$V_{in(min)} \approx 0.4\text{ V peak for } 1\% \text{ phase distortion } (\Delta\Theta).$$

**Figure 3. Zero Crossing Detector (Split Supply)**

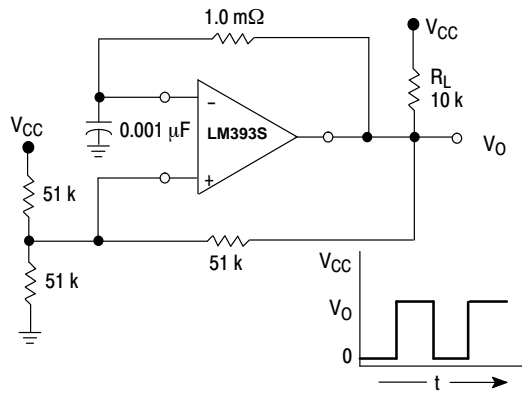

**Figure 4. Free-Running Square-Wave Oscillator**

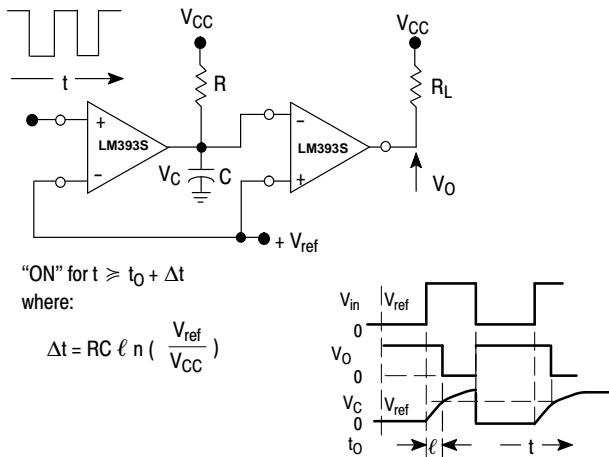

"ON" for  $t \geq t_0 + \Delta t$

where:

$$\Delta t = RC \ell n \left( \frac{V_{ref}}{V_{CC}} \right)$$

**Figure 5. Time Delay Generator**

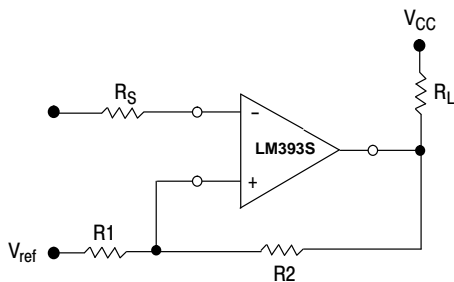

$$R_S = R1 \parallel R2$$

$$V_{th1} = V_{ref} + \frac{(V_{CC} - V_{ref}) R1}{R1 + R2 + R_L}$$

$$V_{th2} = V_{ref} - \frac{(V_{ref} - V_{O\text{ Low}}) R1}{R1 + R2}$$

**Figure 6. Comparator with Hysteresis**

# LM393S, LM2903S

## ORDERING INFORMATION

Device	Operating Temperature Range	Package	Shipping†
LM393SNG	0°C to +70°C	PDIP-8 (Pb-Free)	50 Units / Rail
LM2903SNG	-40°C to +105°C	PDIP-8 (Pb-Free)	50 Units / Rail

†For information on tape and reel specifications, including part orientation and tape sizes, please refer to our Tape and Reel Packaging Specifications Brochure, BRD8011/D.

# LM393S, LM2903S

## PACKAGE DIMENSIONS

### PDIP-8 CASE 626-05 ISSUE N

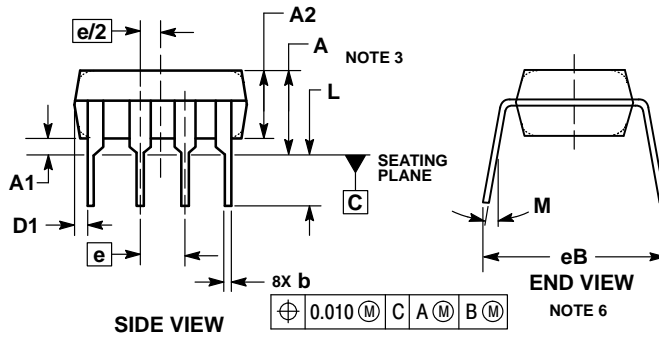
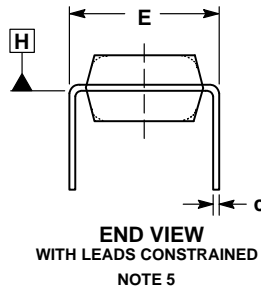
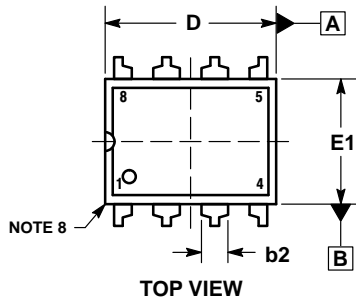

#### NOTES:

1. DIMENSIONING AND TOLERANCING PER ASME Y14.5M, 1994.
2. CONTROLLING DIMENSION: INCHES.
3. DIMENSIONS A, A1 AND L ARE MEASURED WITH THE PACKAGE SEATED IN JEDEC SEATING PLANE GAUGE GS-3.
4. DIMENSIONS D, D1 AND E1 DO NOT INCLUDE MOLD FLASH OR PROTRUSIONS. MOLD FLASH OR PROTRUSIONS ARE NOT TO EXCEED 0.10 INCH.
5. DIMENSION E IS MEASURED AT A POINT 0.015 BELOW DATUM PLANE H WITH THE LEADS CONSTRAINED PERPENDICULAR TO DATUM C.
6. DIMENSION E3 IS MEASURED AT THE LEAD TIPS WITH THE LEADS UNCONSTRAINED.
7. DATUM PLANE H IS COINCIDENT WITH THE BOTTOM OF THE LEADS, WHERE THE LEADS EXIT THE BODY.
8. PACKAGE CONTOUR IS OPTIONAL (ROUNDED OR SQUARE CORNERS).

DIM	INCHES		MILLIMETERS	
	MIN	MAX	MIN	MAX
A	----	0.210	----	5.33
A1	0.015	----	0.38	----
A2	0.115	0.195	2.92	4.95
b	0.014	0.022	0.35	0.56
b2	0.060 TYP		1.52 TYP	
C	0.008	0.014	0.20	0.36
D	0.355	0.400	9.02	10.16
D1	0.005	----	0.13	----
E	0.300	0.325	7.62	8.26
E1	0.240	0.280	6.10	7.11
e	0.100 BSC		2.54 BSC	
eB	----	0.430	----	10.92
L	0.115	0.150	2.92	3.81
M	----	10°	----	10°

**ON Semiconductor** and **ON** are registered trademarks of Semiconductor Components Industries, LLC (SCILLC). SCILLC owns the rights to a number of patents, trademarks, copyrights, trade secrets, and other intellectual property. A listing of SCILLC's product/patent coverage may be accessed at [www.onsemi.com/site/pdf/Patent-Marking.pdf](http://www.onsemi.com/site/pdf/Patent-Marking.pdf). SCILLC reserves the right to make changes without further notice to any products herein. SCILLC makes no warranty, representation or guarantee regarding the suitability of its products for any particular purpose, nor does SCILLC assume any liability arising out of the application or use of any product or circuit, and specifically disclaims any and all liability, including without limitation special, consequential or incidental damages. "Typical" parameters which may be provided in SCILLC data sheets and/or specifications can and do vary in different applications and actual performance may vary over time. All operating parameters, including "Typicals" must be validated for each customer application by customer's technical experts. SCILLC does not convey any license under its patent rights nor the rights of others. SCILLC products are not designed, intended, or authorized for use as components in systems intended for surgical implant into the body, or other applications intended to support or sustain life, or for any other application in which the failure of the SCILLC product could create a situation where personal injury or death may occur. Should Buyer purchase or use SCILLC products for any such unintended or unauthorized application, Buyer shall indemnify and hold SCILLC and its officers, employees, subsidiaries, affiliates, and distributors harmless against all claims, costs, damages, and expenses, and reasonable attorney fees arising out of, directly or indirectly, any claim of personal injury or death associated with such unintended or unauthorized use, even if such claim alleges that SCILLC was negligent regarding the design or manufacture of the part. SCILLC is an Equal Opportunity/Affirmative Action Employer. This literature is subject to all applicable copyright laws and is not for resale in any manner.

### PUBLICATION ORDERING INFORMATION

**LITERATURE FULFILLMENT:**  
Literature Distribution Center for ON Semiconductor  
P.O. Box 5163, Denver, Colorado 80217 USA  
**Phone:** 303-675-2175 or 800-344-3860 Toll Free USA/Canada  
**Fax:** 303-675-2176 or 800-344-3867 Toll Free USA/Canada  
**Email:** [orderlit@onsemi.com](mailto:orderlit@onsemi.com)

**N. American Technical Support:** 800-282-9855 Toll Free  
USA/Canada  
**Europe, Middle East and Africa Technical Support:**  
Phone: 421 33 790 2910  
**Japan Customer Focus Center**  
Phone: 81-3-5817-1050

**ON Semiconductor Website:** [www.onsemi.com](http://www.onsemi.com)  
**Order Literature:** <http://www.onsemi.com/orderlit>  
For additional information, please contact your local Sales Representative

## Looking for pricing, stock, or lifecycle information?

Click below to explore more details on WIN SOURCE:

 [View LM2903SNG](#) on WIN SOURCE

 [ON Semiconductor](#) Information

## Optimize Your Supply Chain with WIN SOURCE Solutions

-  Global Sourcing Solution
-  Obsolete Management
-  Cost Control Management
-  Shortage Management
-  Alternative Solution
-  Excess Inventory Management