



**THE DATASHEET OF
PI90LV047ALE**



3V LVDS Quad Flow-Through Differential Line Driver

Features

- >500 Mbps (250 MHz) switching rates
- Flow-through pinout simplifies PCB layout
- Low Voltage Differential Signaling with output voltages of $\pm 350\text{mV}$ into:
 - 100-ohm load (PI90LV047)
- 300ps typical differential skew
- 400ps maximum differential skew
- 1.7ns maximum propagation delay
- 3.3V power supply design
- $\pm 350\text{mV}$ differential signaling
- Bus-Pin ESD protection $>10\text{kV}$
- Interoperable with existing 5V LVDS receivers
- High impedance on LVDS outputs on power down
- Conforms to TIA/EIA-644 LVDS Standard
- Industrial operating temperature range (-40°C to $+85^{\circ}\text{C}$)
- Packages (Pb-free & Green Available):
 - 16-pin SOIC (W)
 - 16-pin TSSOP (L)

Description

The PI90LV047A is a quad flow-through differential line driver designed for applications requiring ultra-low power dissipation and high data rates. This device is designed to support data rates in excess of 400 Mbps (200 MHz) using Low Voltage Differential Signaling (LVDS) technology.

The PI90LV047A accept low-voltage TTL/CMOS input levels and translates them to low-voltage (350 mV) differential output signals.

In addition, the driver supports a 3-state function that may be used to disable the output stage, disabling the load current, and thus dropping the device to an ultra low idle power state of 13mW typical. This device has a flow-through pinout for easy PCB layout.

The EN and $\overline{\text{EN}}$ inputs are banded together and control the 3-state outputs.

The intended application of this device and signaling technique is for point-to-point baseband (PI90LV047A) data transmission over controlled impedance media.

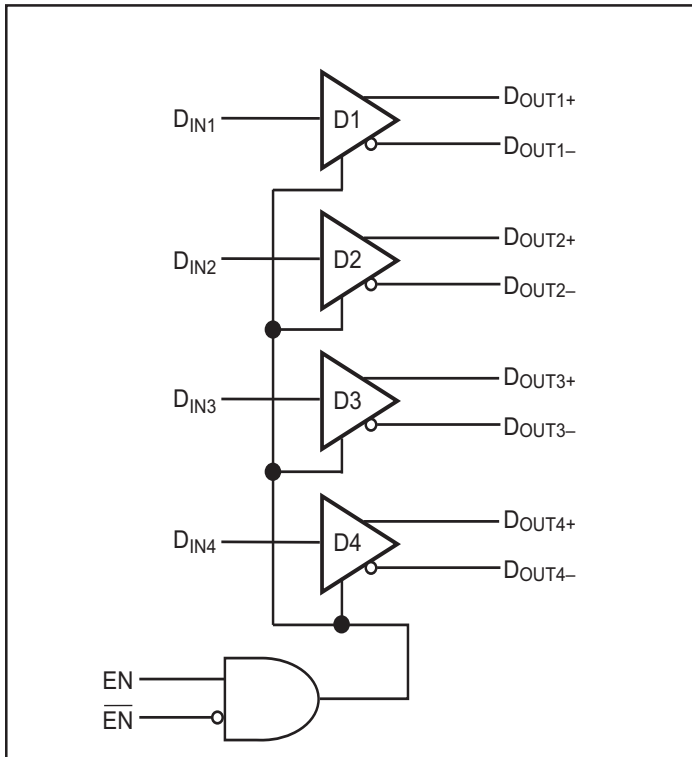
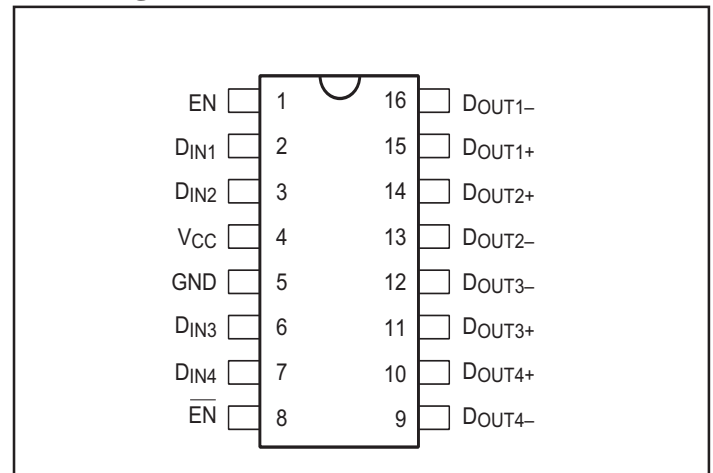
Block Diagram

Pin Configuration

Truth Table

Enables		Input	Outputs	
EN	$\overline{\text{EN}}$	D _{IN}	D _{OUT+}	D _{OUT-}
H	L or Open	L	L	H
		H	H	L
All other combinations of ENABLE inputs		X	Z	Z

Absolute Maximum Ratings

Supply Voltage (V_{CC})	-0.3V to +4V
Input Voltage (D_{IN})	-0.3V to ($V_{CC} + 0.3V$)
Enable Input Voltage (EN, \overline{EN})	-0.3V to ($V_{CC} + 0.3V$)
Output Voltage (D_{OUT+}, D_{OUT-})	-0.3V to +3.9V
Short Circuit Duration (D_{OUT+}, D_{OUT-})	Continuous
Maximum Package Power Dissipation @ +25°C	
M Package	1088mW
MTC Package	866mW
Derate M Package	8.5 mW/°C above +25°C
Derate MTC Package	6.9 mW/°C above +25°C
Storage Temperature Range	-65°C to +150°C

Lead Temperature Range	
Soldering (4 seconds)	+260°C
Maximum Junction Temperature	+150°C
ESD Rating ⁽¹⁰⁾	
(HBM, 1.5kW, 100pF)	≥10kV
(EIAJ, 0W, 200pF)	≥1200V

Recommended Operating Conditions

	Min	Typ	Max	Units
Supply Voltage (V_{CC})	+3.0	+3.3	+3.6	V
Operating Free Air Temperature (T_A)	-40	+25	+85	°C

Electrical Characteristics

Over supply voltage and operating temperature ranges, unless otherwise specified^(2,3,4).

Symbol	Parameter	Test Conditions	Pin	Min.	Typ.	Max.	Units
V_{OD1}	Differential output voltage magnitude	$R_L = 100$ ohms (LV047A) See Figure 1	D_{OUT-} D_{OUT+}	250	310	450	mV
ΔV_{OD1}	Change in Magnitude of V_{OD1} for complementary output states				1	35	mV
V_{OS}	Offset voltage			1.125	1.2	1.375	V
ΔV_{OS}	Change in magnitude of V_{OS} for complementary output states				1	25	mV
V_{OH}	Output high voltage				1.33	1.6	V
V_{OL}	Output low voltage			0.90	1.02		
V_{IH}	Input high voltage		2.0		V_{CC}	V	
V_{IL}	Input low voltage		GND		0.8		
I_{IH}	Input high current	$V_{IN} = V_{CC}$ or 2.5V	$D_{IN},$ $EN,$ \overline{EN}	-20	2	+20	μA
I_{IL}	Input low current	$V_{IN} = GND$ or 0.4V		-10	-2	+10	μA
V_{CL}	Input clamp voltage	$I_{CL} = -18mA$		-1.5	-0.8		V
I_{OS}	Output short circuit current ⁽¹¹⁾	Enabled, $D_{IN} = V_{CC},$ $D_{OUT+} = 0V$ or $D_{IN} = GND, D_{OUT-} = 0V$			-4.2	-10	
I_{OSD}	Differential output short circuit current ⁽¹¹⁾	Enabled, $V_{OD} = 0V$	D_{OUT-} D_{OUT+}		-4.2	-10	
I_{OFF}	Power-off leakage	$V_{OUT} = 0V$ or 3.6V, $V_{CC} = 0V$ or Open		-20	±1	+20	μA
I_{OZ}	Output 3-State current	$EN = 0.8V$ and $\overline{EN} = 2.0V,$ $V_{OUT} = 0V$ or V_{CC}		-10	±1	+10	
I_{CC}	No load supply current drivers enabled	$D_{IN} = V_{CC}$ or GND	V_{CC}		4.0	8.0	mA
I_{CCL}	Loaded supply current drivers enabled	$R_L = 100$ ohms, (all channels) $D_{IN} = V_{CC}$ or GND (all inputs)			20	30	
I_{CCZ}	No load supply current drivers disabled	$D_{IN} = V_{CC}$ or GND, $EN = GND, \overline{EN} = V_{CC}$			2.2	8.0	

Switching Characteristics

$V_{CC} = +3.3V \pm 10\%$, $T_A = -40^\circ C^{(3,9,12)}$

Symbol	Parameter	Test Conditions	Min.	Typ.	Max.	Units
t_{PHLD}	Differential Propagation Delay High to Low	$R_L = 100\text{ohms (LV047)}$ $C_L = 15\text{pF}$ (Figures 2 and 3)	0.5	0.8	1.9	
t_{PLHD}	Differential Propagation Delay Low to High		0.5	1.2	1.9	
t_{SKD1}	Differential Pulse Skew $t_{PHLD} - t_{PLHD}^{(5)}$		0	0.3	0.4	
t_{SKD2}	Channel-to-Channel Skew ⁽⁶⁾		0	0.4	0.5	
t_{SKD3}	Differential Part-to-Part Skew ⁽⁷⁾		0		1.0	
t_{SKD4}	Differential Part-to-Part Skew ⁽⁸⁾		0		1.2	
t_{TLH}	Rise Time			0.5	1.5	
t_{THL}	Fall Time			0.5	1.5	
t_{PHZ}	Disable Time High to Z	$R_L = 100\text{ohms (LV047)}$ $C_L = 15\text{pF}$ (Figures 4 and 5)			5	
t_{PLZ}	Disable Time Low to Z				5	
t_{PZH}	Enable Time Z to High				7	
t_{PZL}	Enable Time Z to Low				7	
f_{MAX}	Maximum Operating Frequency ⁽¹⁴⁾					

Notes

- “Absolute Maximum Ratings” are those values beyond which the safety of the device cannot be guaranteed. They are not meant to imply that the devices should be operated at these limits. The table of “Electrical Characteristics” specifies conditions of device operation.
- Current into device pins is defined as positive. Current out of device pins is defined as negative. All voltages are referenced to ground except: V_{OD1} and ΔV_{OD1} .
- All typicals are given for: $V_{CC} = +3.3V$, $T_A = +25^\circ C$.
- The PI90LV047A is a current mode device and only functions within datasheet specifications when a resistive load is applied to the driver outputs typical range is (90 ohms to 110 ohms).
- $t_{SKD1} |t_{PHLD} - t_{PLHD}|$ is the magnitude difference in differential propagation delay time between the positive going edge and the negative going edge of the same channel.
- t_{SKD2} is the Differential Channel-to-Channel Skew of any event on the same device.
- t_{SKD3} , Differential Part to Part Skew, is defined as the difference between the minimum and maximum specified differential propagation delays. This specification applies to devices at the same V_{CC} and within $5^\circ C$ of each other within the operating temperature range.
- t_{SKD4} , part to part skew, is the differential channel-to-channel skew of any event between devices. This specification applies to devices over recommended operating temperature and voltage ranges, and across process distribution. t_{SKD4} is defined as $|Max - Min|$ differential propagation delay.
- Generator waveform for all tests unless otherwise specified: $f = 1 \text{ MHz}$, $Z_O = 50 \text{ ohms}$, $t_r \leq 1 \text{ ns}$, and $t_f \leq 1 \text{ ns}$.
- ESD Ratings:
 HBM (1.5 kohms, 100pF) $\geq 10\text{kV}$
 EIAJ (0 ohm, 200pF) $\geq 1200\text{V}$
- Output short circuit current (I_{OS}) is specified as magnitude only, minus sign indicates direction only.
- C_L includes probe and jig capacitance.
- All input voltages are for one channel unless otherwise specified. Other inputs are set to GND.
- f_{MAX} generator input conditions: $t_r = t_f < 1\text{ns}$ (0% to 100%), 50% duty cycle, 0V to 3V.
 Output Criteria: duty cycle = 45%/55%, $V_{OD} > 250\text{mV}$, all channels switching.

Parameter Measurement Information

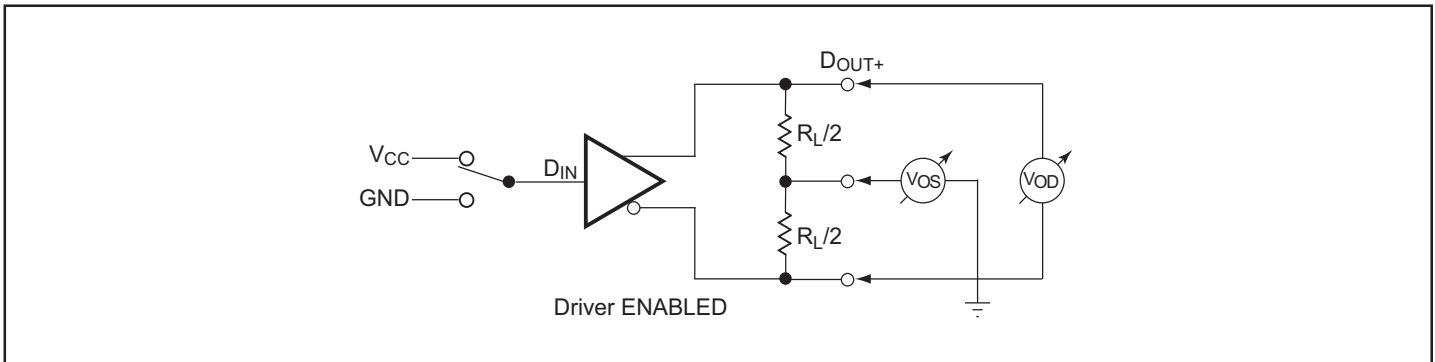

Figure 1. Driver V_{OD} and V_{OS} Test Circuit

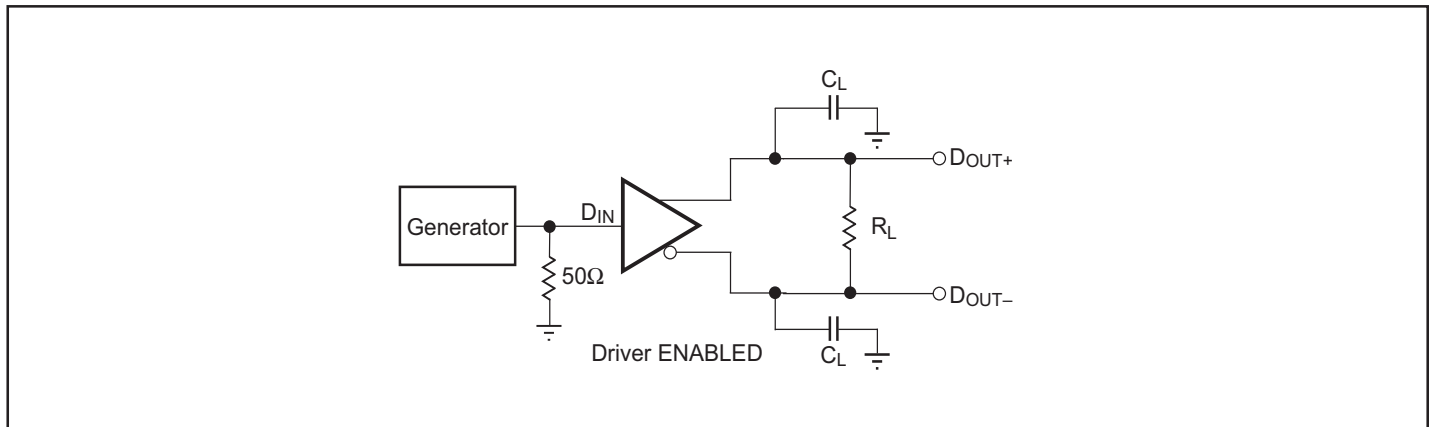

Figure 2. Driver Propagation Delay & Transition Time Test Circuit

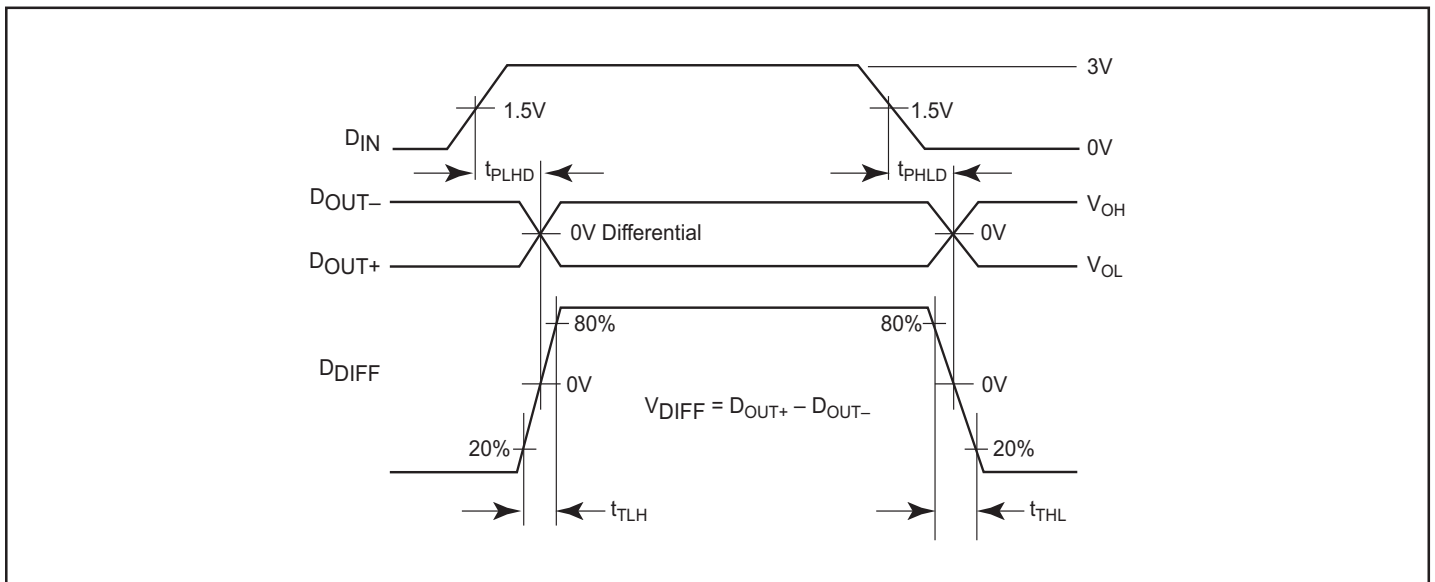

Figure 3. Driver Propagation Delay and Transition Time Waveforms

Parameter Measurement Information (continued)

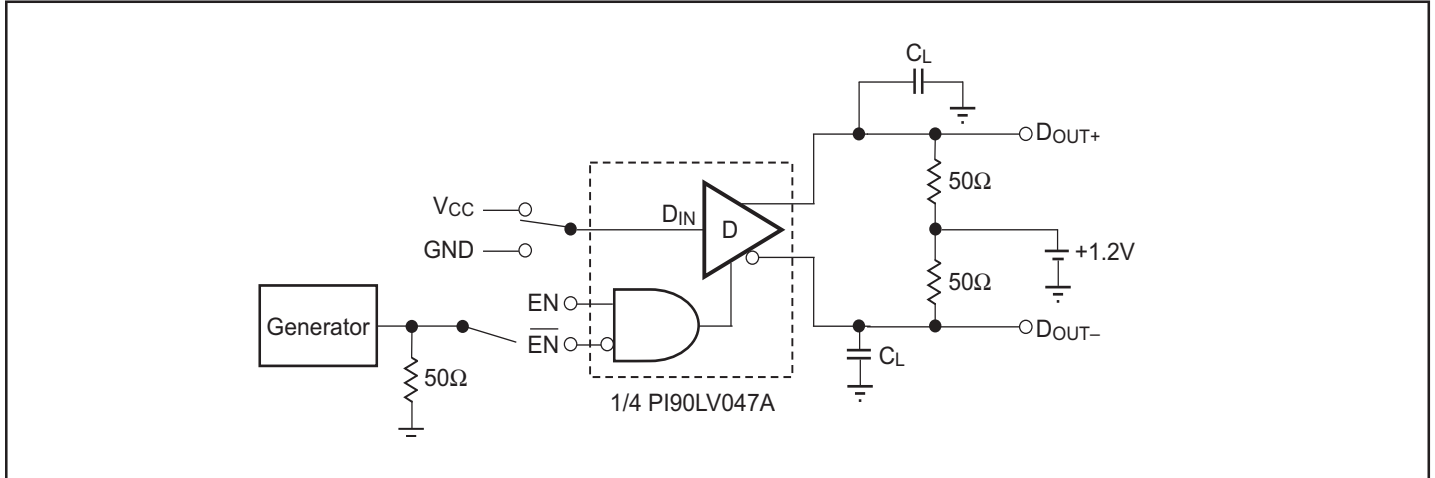

Figure 4. Drive 3-State Delay Test Circuit

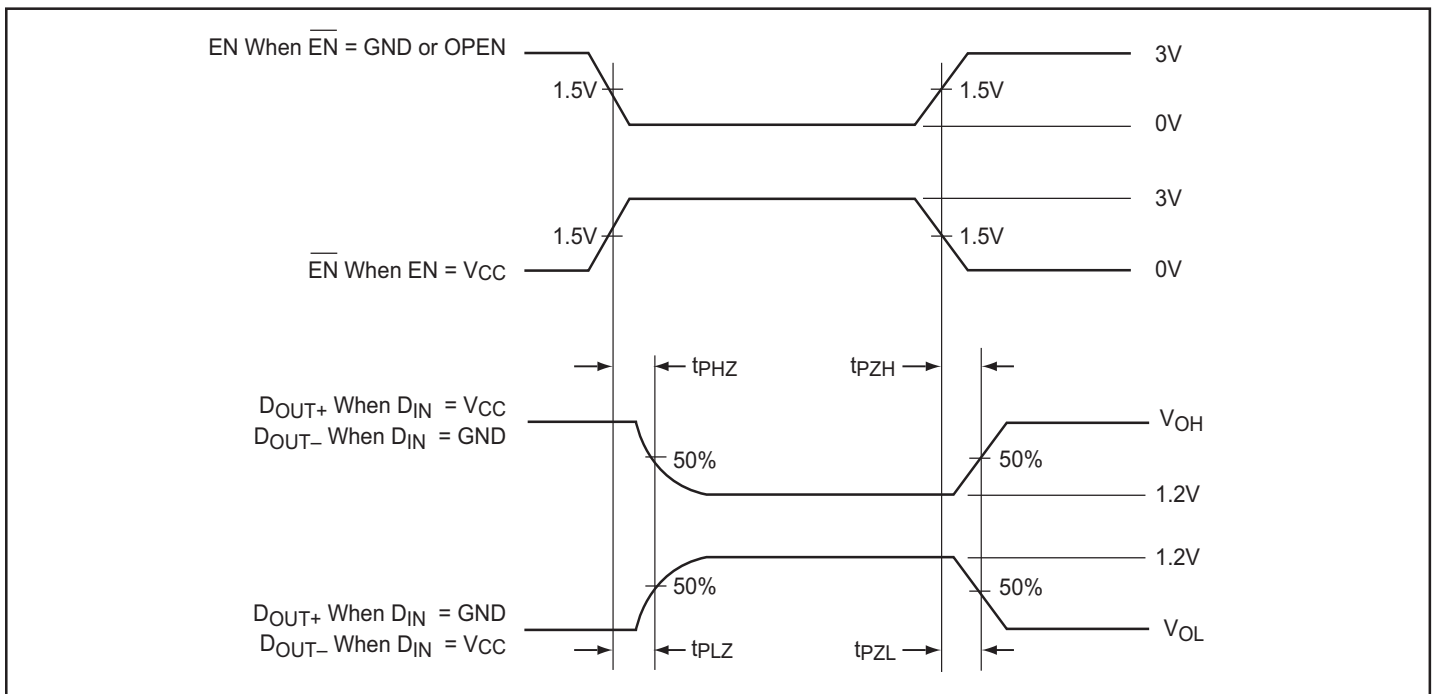

Figure 5. Driver 3-State Delay Waveform

Typical Application

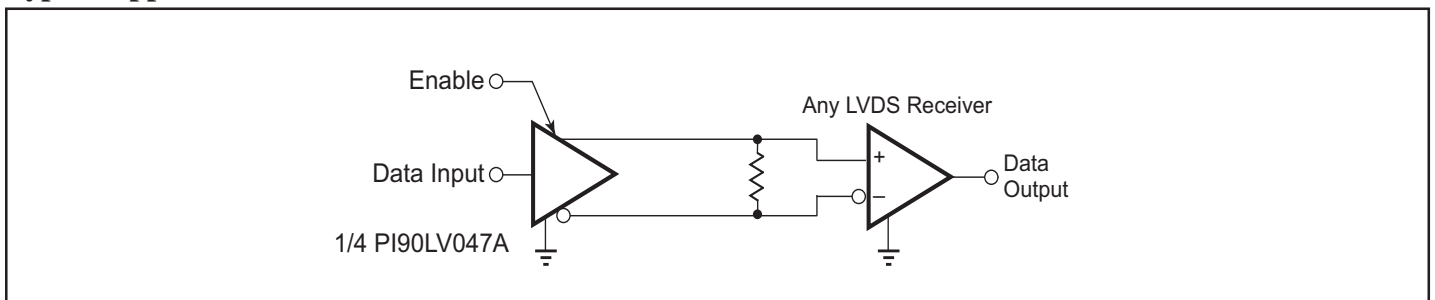
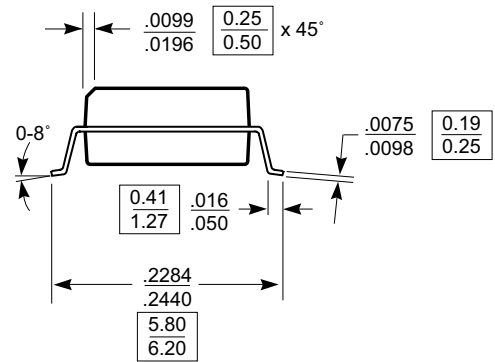
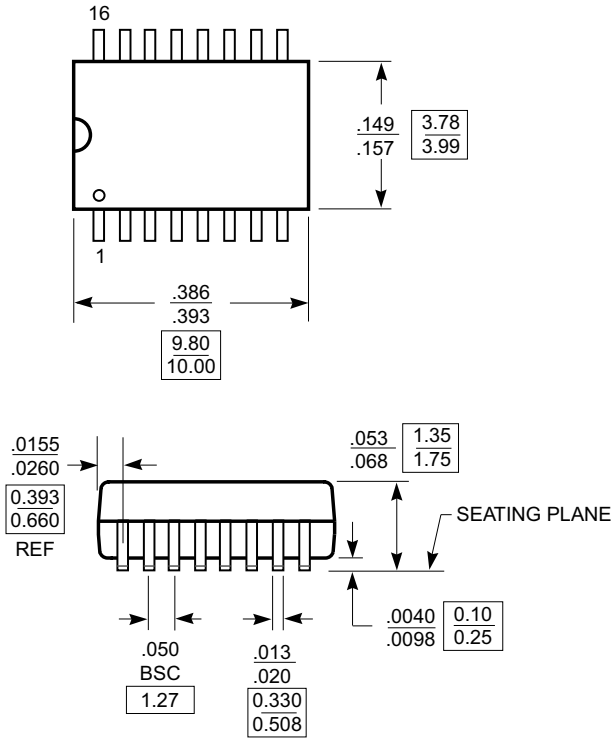

Figure 6. Point-to-Point Application

Packaging Mechanical: 16-Pin SOIC (W)

DOCUMENT CONTROL NO.
PD - 1004

REVISION: E
DATE: 03/09/05



X.XX DENOTES DIMENSIONS
X.XX IN MILLIMETERS

- Notes:
1) Controlling dimensions in millimeters.
2) Ref. JEDEC MS-012D/AC



Pericom Semiconductor Corporation
3545 N. 1st Street, San Jose, CA 95134
1-800-435-2335 • www.pericom.com

DESCRIPTION: 16-Pin, 150-Mil Wide, SOIC

PACKAGE CODE: W

Packaging Mechanical: 16-Pin TSSOP (L)

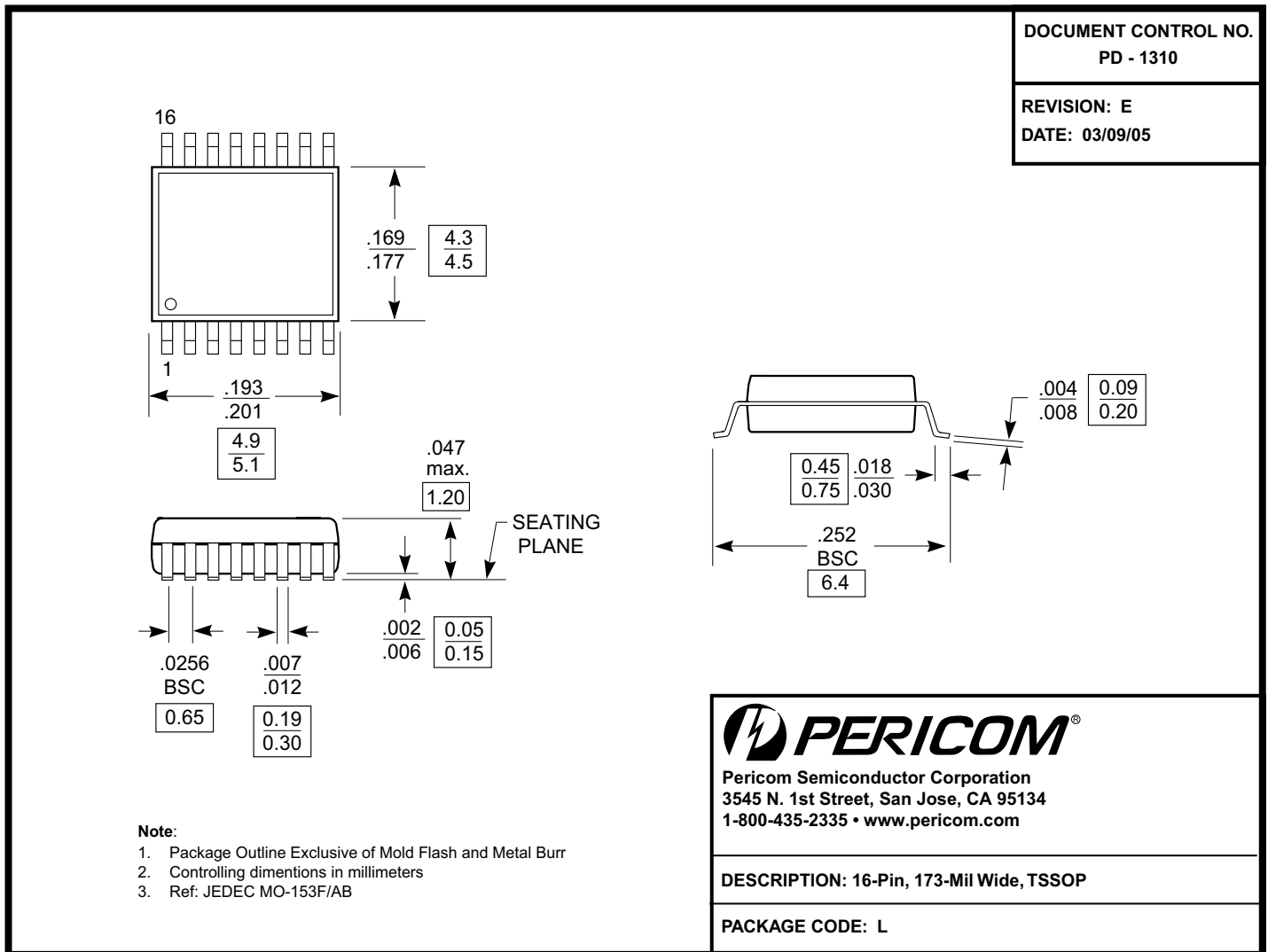

Ordering Information

Ordering Code	Package Code	Package Type
PI90LV047AWE	W	Pb-free & Green, 16-pin SOIC
PI90LV047ALE	L	Pb-free & Green, 16-pin TSSOP

Notes:

- Thermal characteristics can be found on the company web site at www.pericom.com/packaging/
- E = Pb-free and Green
- X = Tape and reel

Looking for pricing, stock, or lifecycle information?

Click below to explore more details on WIN SOURCE:

 [View PI90LV047ALE on WIN SOURCE](#)

 [Diodes Incorporated](#) Information

Optimize Your Supply Chain with WIN SOURCE Solutions

-  Global Sourcing Solution
-  Obsolete Management
-  Cost Control Management
-  Shortage Management
-  Alternative Solution
-  Excess Inventory Management