



THE DATASHEET OF TUSB211IRWBR



TUSB211 USB 2.0 High Speed Signal Conditioner

1 Features

- Compatible with USB 2.0, OTG 2.0 and BC 1.2
- Support for LS, FS, HS signaling
- Active Power Consumption of 55 mW (Typical) with 3.3-V Single Supply
- Selectable Signal Gain Via External Pulldown Resistor
- Does Not Break DP, DM Trace
- Scalable Solution – Daisy Chain Device for High Loss Applications
- Compact 1.6 mm x 1.6 mm QFN Package

2 Applications

- Notebooks
- Desktops
- Docking Stations
- Cell Phones
- Active Cable, Cable Extenders
- Backplane
- Televisions
- Tablets

3 Description

The TUSB211 is a USB High-Speed (HS) signal conditioner, designed to compensate for ISI signal loss in a transmission channel.

The device has a patent-pending design which is agnostic to USB Low Speed (LS) and Full Speed (FS) signals. LS and FS signal characteristics are unaffected by the TUSB211. HS signals are compensated.

Programmable signal gain permits fine tuning device performance to optimize High Speed signals at the connector. This helps to pass USB High Speed electrical compliance tests.

The footprint of TUSB211 does not break the continuity of the DP/DM signal path. This permits risk free system design of a complete USB channel.

In addition, TUSB211 is compatible with the USB On-The-Go (OTG) and Battery Charging (BC) protocols

Device Information ⁽¹⁾

PART NUMBER	PACKAGE	BODY SIZE (NOM)
TUSB211	X2QFN (12)	1.60 mm x 1.60 mm
TUSB211I		

(1) For all available packages, see the orderable addendum at the end of the datasheet.

Simplified Schematic

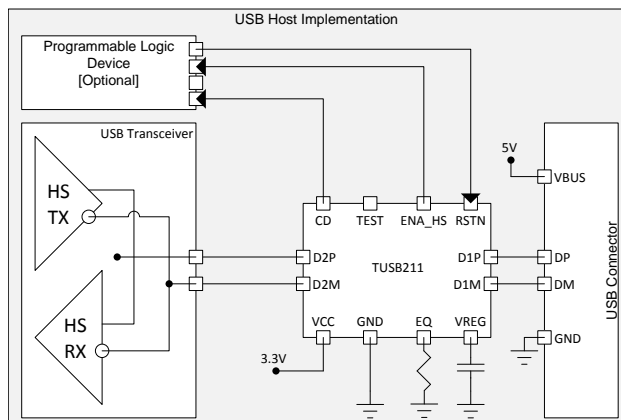

Copyright © 2016, Texas Instruments Incorporated



Table of Contents

1 Features	1	7.3 Device Functional Modes.....	7
2 Applications	1	8 Application and Implementation	8
3 Description	1	8.1 Application Information.....	8
4 Revision History	2	8.2 Typical Application	8
5 Pin Configuration and Functions	3	9 Power Supply Recommendations	11
6 Specifications	4	10 Layout	12
6.1 Absolute Maximum Ratings	4	10.1 Layout Guidelines	12
6.2 ESD Ratings.....	4	10.2 Layout Example	12
6.3 Recommended Operating Conditions.....	4	11 Device and Documentation Support	13
6.4 Thermal Information	4	11.1 Related Links	13
6.5 Electrical Characteristics.....	5	11.2 Community Resources.....	13
6.6 Switching Characteristics	6	11.3 Trademarks	13
7 Detailed Description	7	11.4 Electrostatic Discharge Caution.....	13
7.1 Overview	7	11.5 Glossary	13
7.2 Functional Block Diagram	7	12 Mechanical, Packaging, and Orderable Information	13

4 Revision History

Changes from Revision C (June 2016) to Revision D	Page
• Deleted device TUSB211-Q1 From the data sheet.....	1
• Deleted <i>Features</i> : Qualified for Automotive Applications	1
• Deleted <i>Applications</i> : Automotive Infotainment	1

Changes from Revision A (June 2015) to Revision B	Page
• Changed From: 1-page datasheet To: Full datasheet	1
• Added <i>Features</i> : Qualified for Automotive Applications	1
• Deleted <i>Features</i> : –40°C to 85°C Industrial Temperature Range.....	1
• Added <i>Applications</i> : Automotive Infotainment	1
• Changed the <i>Simplified Schematic</i>	1

Changes from Original (May 2015) to Revision A	Page
• Changed the data sheet From: Product Preview To: Production	1

5 Pin Configuration and Functions

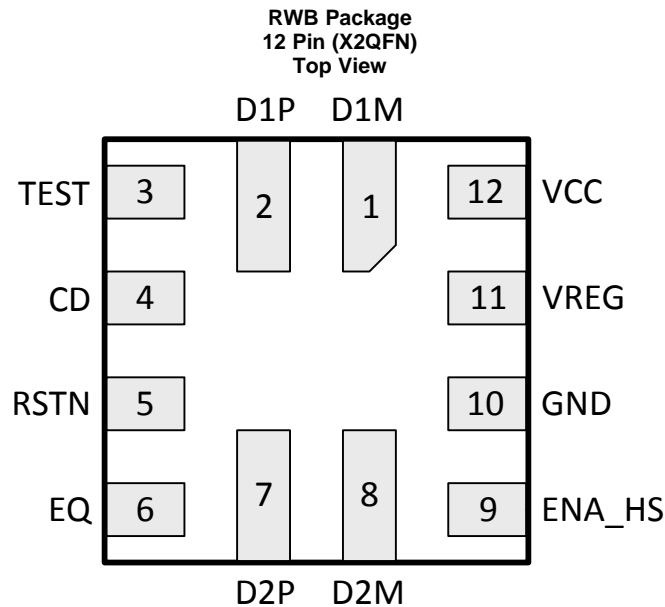

Pin Functions

PIN		I/O	INTERNAL PULLUP/PULLDOWN	DESCRIPTION
NAME	NO.			
VCC	12	P	N/A	3.3-V power
VREG	11	O	RSTN asserted: 30 kΩ PD FS, LS mode: 30 kΩ PD HS mode: N/A	1.8-V LDO output. Only enabled when operating in High Speed mode. Requires 0.1-μF external capacitor to GND to stabilize the core.
GND	10	P	N/A	Ground
RSTN	5	I	500 kΩ PU	Device disable/enable. Recommend 0.1-μF external capacitor to GND to ensure clean power on reset if not driven.
EQ	6	I	N/A	USB High Speed boost select via external pull down resistor. Sampled upon power up. Auto selects min EQ when left floating. Does not recognize real time adjustments.
D1P	2	I/O	N/A	USB High Speed positive port. Orientation independent – Can face either upstream or downstream.
D1M	1	I/O	N/A	USB High Speed negative port. Orientation independent – Can face either upstream or downstream.
D2P	7	I/O	N/A	USB High Speed positive port. Orientation independent – Can face either upstream or downstream.
D2M	8	I/O	N/A	USB High Speed negative port. Orientation independent – Can face either upstream or downstream.
TEST	3	I	RSTN asserted: 500 kΩ PD	No function. Leave floating.
ENA_HS	9	O	RSTN asserted: 500kΩ PD	Flag indicating that channel is in High Speed mode. Asserted upon: 1. Detection of USB-IF High Speed test fixture from an unconnected state followed by transmission of USB TEST_PACKET pattern. 2. Squelch detection following USB reset with a successful HS handshake [HS handshake is declared to be successful after single chirp J chirp K pair where each chirp is within 18 μs – 128 μs] De-asserted upon detection of disconnect or suspend. Can be left floating if not needed.
CD	4	O	RSTN asserted: 500 kΩ PD	Flag indicating that a USB device is attached. Asserted from an unconnected state upon detection of DP or DM pull-up resistor. De-asserted upon detection of disconnect. Can be left floating if not needed.

6 Specifications

6.1 Absolute Maximum Ratings

over operating free-air temperature range (unless otherwise noted) ⁽¹⁾

		MIN	MAX	UNIT
Supply voltage range	VCC	-0.3	3.8	V
Voltage range	D1P, D1M, D2P, D2M, RSTN, EQ	-0.3	3.8	V
Storage temperature, T _{stg}		-65	150	°C

- (1) Stresses beyond those listed under *Absolute Maximum Ratings* may cause permanent damage to the device. These are stress ratings only, which do not imply functional operation of the device at these or any other conditions beyond those indicated under *Recommended Operating Conditions*. Exposure to absolute-maximum-rated conditions for extended periods may affect device reliability.

6.2 ESD Ratings

		VALUE	UNIT
V _(ESD) Electrostatic discharge	Human-body model (HBM), per ANSI/ESDA/JEDEC JS-001 ⁽¹⁾	±3000	V
	Charged-device model (CDM), per JEDEC specification JESD22-C101 ⁽²⁾	±1000	

- (1) JEDEC document JEP155 states that 500-V HBM allows safe manufacturing with a standard ESD control process.
 (2) JEDEC document JEP157 states that 250-V CDM allows safe manufacturing with a standard ESD control process.

6.3 Recommended Operating Conditions

over operating free-air temperature range (unless otherwise noted)

		MIN	NOM	MAX	UNIT
V _{CC}	Supply voltage	3	3.3	3.6	V
T _A	Operating free-air temperature [TUSB211]	0		70	°C
	Operating free-air temperature [TUSB211I]	-40		85	

6.4 Thermal Information

THERMAL METRIC ⁽¹⁾		RWB	UNIT
		12 PINS	
R _{θJA}	Junction-to-ambient thermal resistance	161.6	°C/W
R _{θJC(top)}	Junction-to-case (top) thermal resistance	63.3	°C/W
R _{θJB}	Junction-to-board thermal resistance	75.1	°C/W
ψ _{JT}	Junction-to-top characterization parameter	1.9	°C/W
ψ _{JB}	Junction-to-board characterization parameter	75.1	°C/W
R _{θJC(bot)}	Junction-to-case (bottom) thermal resistance	N/A	°C/W

- (1) For more information about traditional and new thermal metrics, see the *Semiconductor and IC Package Thermal Metrics* application report, [SPRA953](#).

6.5 Electrical Characteristics

over operating free-air temperature range (unless otherwise noted)

PARAMETER		TEST CONDITIONS	MIN	TYP ⁽¹⁾	MAX	UNIT
$I_{(ACTIVE_HS)}$	High Speed Active Current	USB channel = HS mode. 480 Mbps traffic. V_{CC} supply stable		16	20	mA
$I_{(IDLE_HS)}$	High Speed Idle Current	USB channel = HS mode. No traffic. V_{CC} supply stable		12	15	mA
$I_{(SUSPEND_HS)}$	Suspend Current	USB channel = Suspend mode.		4.5	5.5	mA
$I_{(FS)}$	Full-Speed Current	USB channel = FS mode		4.5	5.5	mA
$I_{(LS)}$	Low-Speed Current	USB channel = LS mode		4.5	5.5	mA
$I_{(DISCONN)}$	Disconnect Power	Host side application. No device attachment.		4.5	5.5	mA
$I_{(RSTN)}$	Disable Power	RSTN driven low; V_{CC} supply stable; $V_{CC} = 3.3\text{ V}$		4.5	5.5	mA
RSTN						
V_{IH}	High level input voltage		2		V_{CC}	V
V_{IL}	Low-level input voltage		0		0.8	V
I_{IH}	High level input current	$V_{IH} = 3.6\text{ V}$, $V_{CC} = 3\text{ V}$, RPU enabled			± 2	μA
I_{IL}	Low level input current	$V_{IL} = 0\text{ V}$, $V_{CC} = 3.6\text{ V}$, RPU enabled			± 11	μA
EQ						
$R_{(EQ)}$	External pulldown resistor	Level 0 EQ			0.32	k Ω
		Level 1 EQ	1.4		2.2	k Ω
		Level 2 EQ [MAX]	3.7		4.1	k Ω
		Level 3 EQ [MIN]	6			k Ω
CD, ENA_HS						
V_{OH}	High level output voltage	$I_O = -50\ \mu\text{A}$	2.4			V
V_{OL}	Low level output voltage	$I_O = 50\ \mu\text{A}$			0.4	V
DxP, DxM						
$T_{(SHRT_GND)}$	DP, DM low voltage short circuit	DxP or DxM short circuited to GND continuously for 24 hours at $T_A = 25^\circ\text{C}$ only	0			V
$C_{IO(DXX)}$	Capacitance to GND	Measured with LCR meter and device powered down. 1 MHz sinusoid, 30 mVpp ripple		5		pF

 (1) (1) All typical values are at $V_{CC} = 3.3\text{ V}$, and $T_A = 25^\circ\text{C}$.

6.6 Switching Characteristics

over operating free-air temperature range (unless otherwise noted)

PARAMETER		TEST CONDITIONS	MIN	TYP ⁽¹⁾	MAX	UNIT
DxP, DxM						
F _(BR_DXX)	Bit Rate	USB channel = HS mode. 480 Mbps traffic. V _{CC} supply stable			480	Mbps
t _(R/F_DXX)	Rise/Fall time		100			ps
CD, ENA_HS						
t _(EN)	Enable time			20		μs
t _(DIS)	Disable time			20		μs
VCC						
t _(STABLE)	V _{CC} stable before RSTN de-assertion		100			μs
t _(RAMP)	V _{CC} ramp time		0.2		100	ms

(1) (1) All typical values are at V_{CC} = 3.3 V, and T_A = 25°C.

7 Detailed Description

7.1 Overview

The TUSB211 is a USB High-Speed (HS) signal conditioner, designed to compensate for ISI signal loss in a transmission channel. TUSB211 has a patent-pending design which is agnostic to USB Low Speed (LS) and Full Speed (FS) signals and does not alter their signal characteristics, while HS signals are compensated. In addition, the design is compatible with USB On-The-Go (OTG) and Battery Charging (BC) specifications.

Programmable signal gain through an external resistor permits fine tuning device performance to optimize signals helping to pass USB HS electrical compliance tests at the connector.

The footprint of TUSB211 allows a board layout using this device such that it does not break the continuity of the DP/DM signal traces. This permits risk free system design of a complete USB channel with flexible use of one or multiple TUSB211 devices as needed for optimal signal integrity. This allows system designers to plan for this device and use it only if signal integrity analysis and/or lab measurements show a need. If such a need is not warranted, the device can be left unpopulated without any board rework.

7.2 Functional Block Diagram

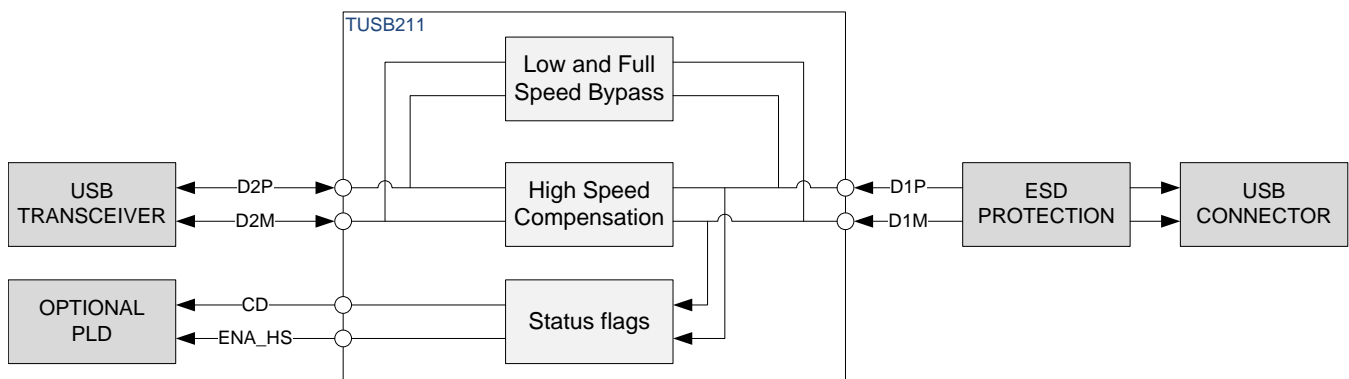

Copyright © 2016, Texas Instruments Incorporated

7.3 Device Functional Modes

7.3.1 Low Speed (LS) Mode

TUSB211 automatically detects a LS connection and does not enable signal compensation. CD pin is asserted high.

7.3.2 Full Speed (FS) Mode

TUSB211 automatically detects a FS connection and does not enable signal compensation. CD pin is asserted high.

7.3.3 High Speed (HS) Mode

TUSB211 automatically detects a HS connection and enables signal compensation as determined by the configuration of the external pulldown resistance on its EQ pin. ENA_HS pin asserted high in addition to the CD pin.

7.3.4 Disable Mode

TUSB211 can be disabled when its RSTN pin is asserted low. The USB channel is still fully operational, but there is neither signal compensation, nor any indication from the CD pin or ENA_HS pin as to the status of the channel.

8 Application and Implementation

NOTE

Information in the following applications sections is not part of the TI component specification, and TI does not warrant its accuracy or completeness. TI's customers are responsible for determining suitability of components for their purposes. Customers should validate and test their design implementation to confirm system functionality.

8.1 Application Information

The primary purpose of the TUSB211 is to re-store the signal integrity of a USB High Speed channel up to the USB connector. The loss in signal quality stems from reduced channel bandwidth due to high loss PCB trace and other components that contribute a capacitive load. This can cause the channel to fail the USB near end eye mask. Proper use of the TUSB211 can help to pass this eye mask.

A secondary purpose is to use the CD pin and ENA_HS pin of the TUSB211 to control other blocks on the customer platform if so desired.

8.2 Typical Application

A typical application is shown below. In this setup, D1P and D1M face the USB connector while D2P and D2M face the USB transceiver. If desired, the orientation may be reversed [that is, D1 faces transceiver and D2 faces connector].

Note that CD and ENA_HS are connected to PLDs. This is for platforms where other circuit blocks must be modified based on the status of the USB channel. They could also be connected to LEDs to give a physical indication of current channel status for debug purposes. If neither use is desired, they can be left floating.

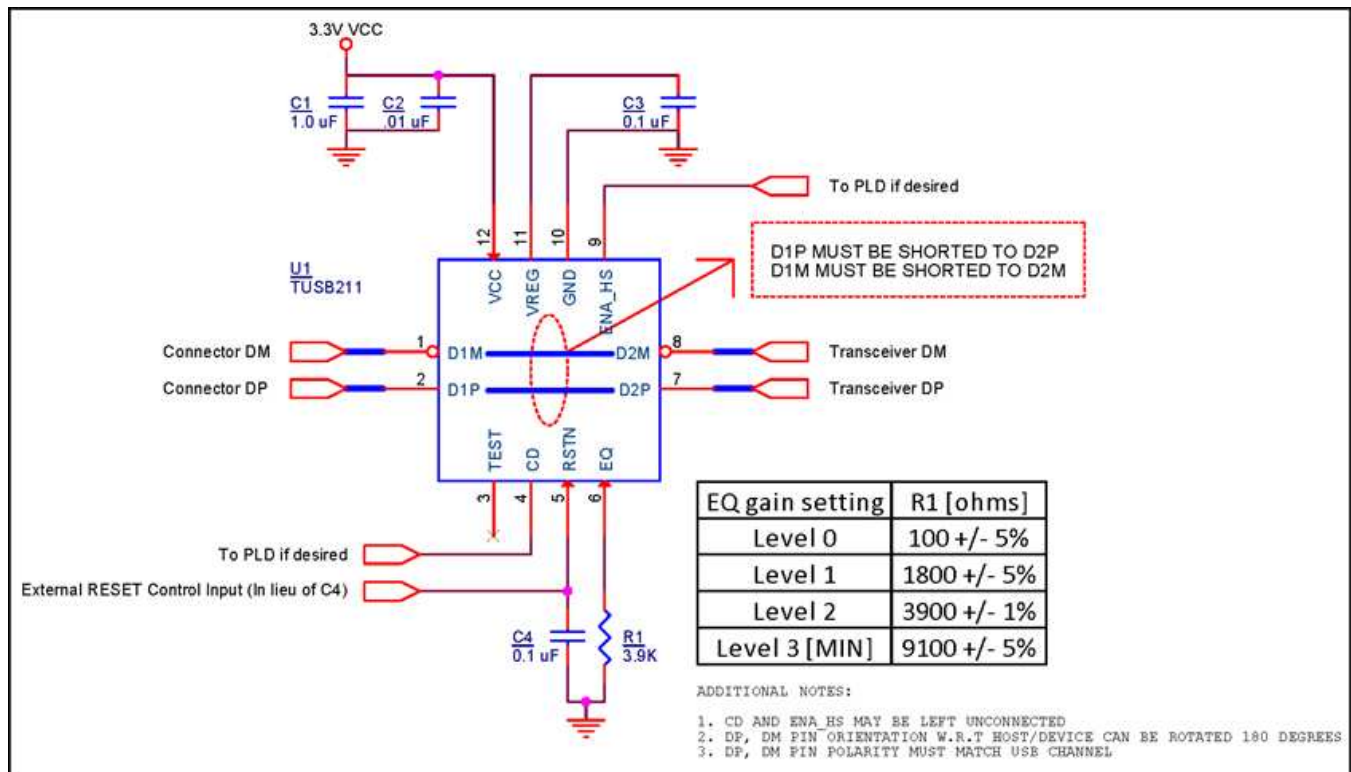

Copyright © 2016, Texas Instruments Incorporated

Figure 1. Reference Schematic

Typical Application (continued)

8.2.1 Design Requirements

TUSB211 requires a valid reset signal as described in the power supply recommendations section. The capacitor C4 is not required if a microcontroller drives the RSTN pin according to recommendations.

Pin 11 VREG is an internal LDO output that requires a 0.1 μ F external capacitor to GND to stabilize the core.

Pin 6 EQ requires an external pulldown resistor if EQ levels 0-2 are needed. If EQ level 3 is needed, then the EQ pin can be left floating.

8.2.2 Detailed Design Procedure

The ideal EQ setting is dependent upon the signal chain loss characteristics of the target platform. The general recommendation is to start with EQ level 0, and then increment to EQ level 1, and so on, if permissible.

In order for the TUSB211 to recognize any change to the EQ setting, the RSTN pin must be toggled. This is because the EQ pin is latched on power up and the pin is ignored thereafter.

In addition, TUSB211 does not compensate for any DC attenuation in the signal path. Therefore, minimizing DC loss (that is, resistance) in the system design, is suggested. As a consequence, this might lead to increased line capacitance. This is acceptable because the TUSB211 can compensate for the additional capacitive load.

Placement of the device is also dependent on the application goal. [Table 1](#) summarizes the recommendations.

Table 1. TUSB211 Platform Placement Guideline

PLATFORM GOAL	SUGGESTED TUSB211 PLACEMENT
Pass USB Near End Mask	Close to measurement point
Pass USB Far End Eye Mask	Close to USB PHY
Cascade multiple 211s to improve device enumeration	Midway between each USB interconnect

NOTE

USB-IF certification tests for High Speed eye masks require the *mandated use* of the USB-IF developed test fixtures. These test fixtures do not require the use of oscilloscope probes. Instead they use SMA cables. More information can be found at the USB-IF Compliance Updates Page. It is located under the 'Electricals' section, ID 86 dated March 2013.

The following procedure must be followed before using any oscilloscope compliance software to construct a USB High Speed Eye Mask:

8.2.2.1 For a Host Side Application

1. Configure the TUSB211 to the desired EQ setting
2. Power on (or toggle the RSTN pin if already powered on) the TUSB211
3. Using SMA cables, connect the oscilloscope and the USB-IF host-side test fixture to the TUSB211
4. Enable the host to transmit USB TEST_PACKET
5. Execute the oscilloscope's USB compliance software.
6. Repeat the above steps in order to re-test TUSB211 with a different EQ setting

8.2.2.2 For a Device Side Application

1. Configure the TUSB211 to the desired EQ setting
2. Power on (or toggle the RSTN pin if already powered on) the TUSB211
3. Connect a USB host, the USB-IF device-side test fixture, and USB device to the TUSB211. Ensure that the USB-IF device test fixture is configured to the 'INIT' position
4. Allow the host to enumerate the device
5. Enable the device to transmit USB TEST_PACKET
6. Using SMA cables, connect the oscilloscope to the USB-IF device-side test fixture and ensure that the device-side test fixture is configured to the 'TEST' position.
7. Execute the oscilloscope's USB compliance software.
8. Repeat the above steps in order to re-test TUSB211 with a different EQ setting

8.2.3 Application Curves

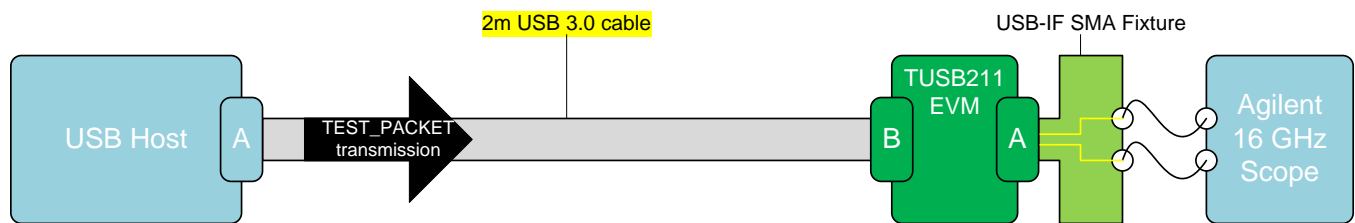

Figure 2. Eye Diagram Bench Setup

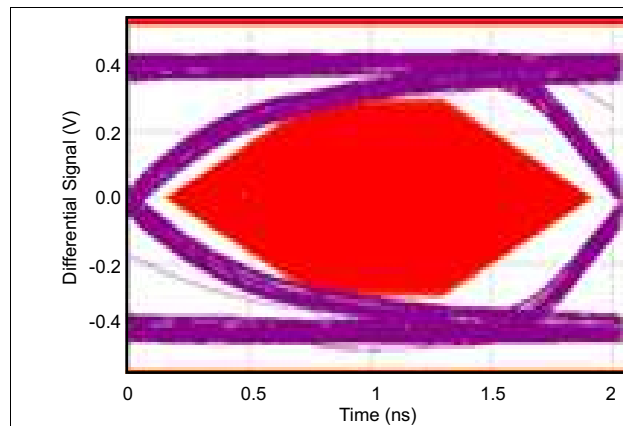

Figure 3. TUSB211 Disabled

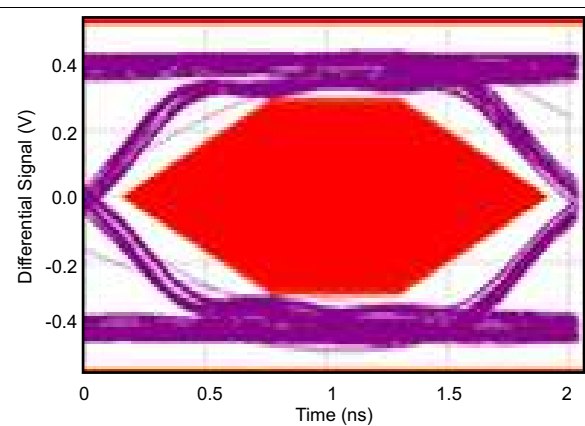

Figure 4. EQ Level 0

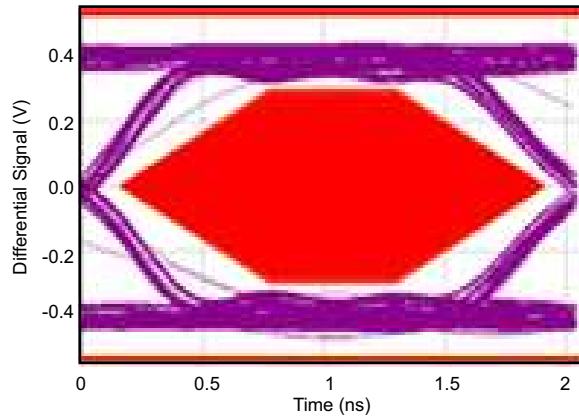

Figure 5. EQ Level 1

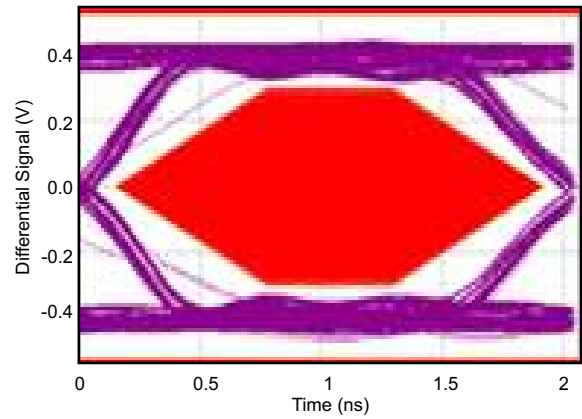

Figure 6. EQ Level 2

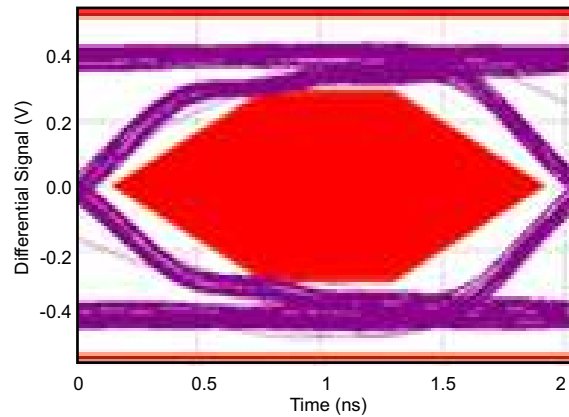

Figure 7. EQ Level 3

9 Power Supply Recommendations

On power up, the interaction of the RSTN pin and power on ramp could result in digital circuits not being set correctly. The device should not be enabled until the power on ramp has settled to 3 V or higher to guarantee a correct power on reset of the digital circuitry. If RSTN cannot be held low by microcontroller or other circuitry until the power on ramp has settled, then an external capacitor from the RSTN pin to GND is required to hold the device in the low power reset state.

The RC time constant should be larger than five times of the power on ramp time (0 to V_{CC}). With a typical internal pullup resistance of 500 k Ω , the recommended minimum external capacitance is calculated as:

$$[\text{Ramp Time} \times 5] \div [500 \text{ k}\Omega] \quad (1)$$

10 Layout

10.1 Layout Guidelines

There is no need to break the USB signal trace. Thus, even with the TUSB211 powered down, or not populated, the USB link is still fully operational. To avoid the need for signal vias, routing the High Speed traces directly underneath the TUSB211 package, as illustrated in the PCB land pattern shown in [Figure 8](#), is recommended.

Although the land pattern shown below has matched trace width to pad width, optimal impedance control is based on the user's own PCB stack-up. It is recommended to maintain 90 Ω differential routing underneath the device.

All dimensions are in millimetres (mm).

10.2 Layout Example

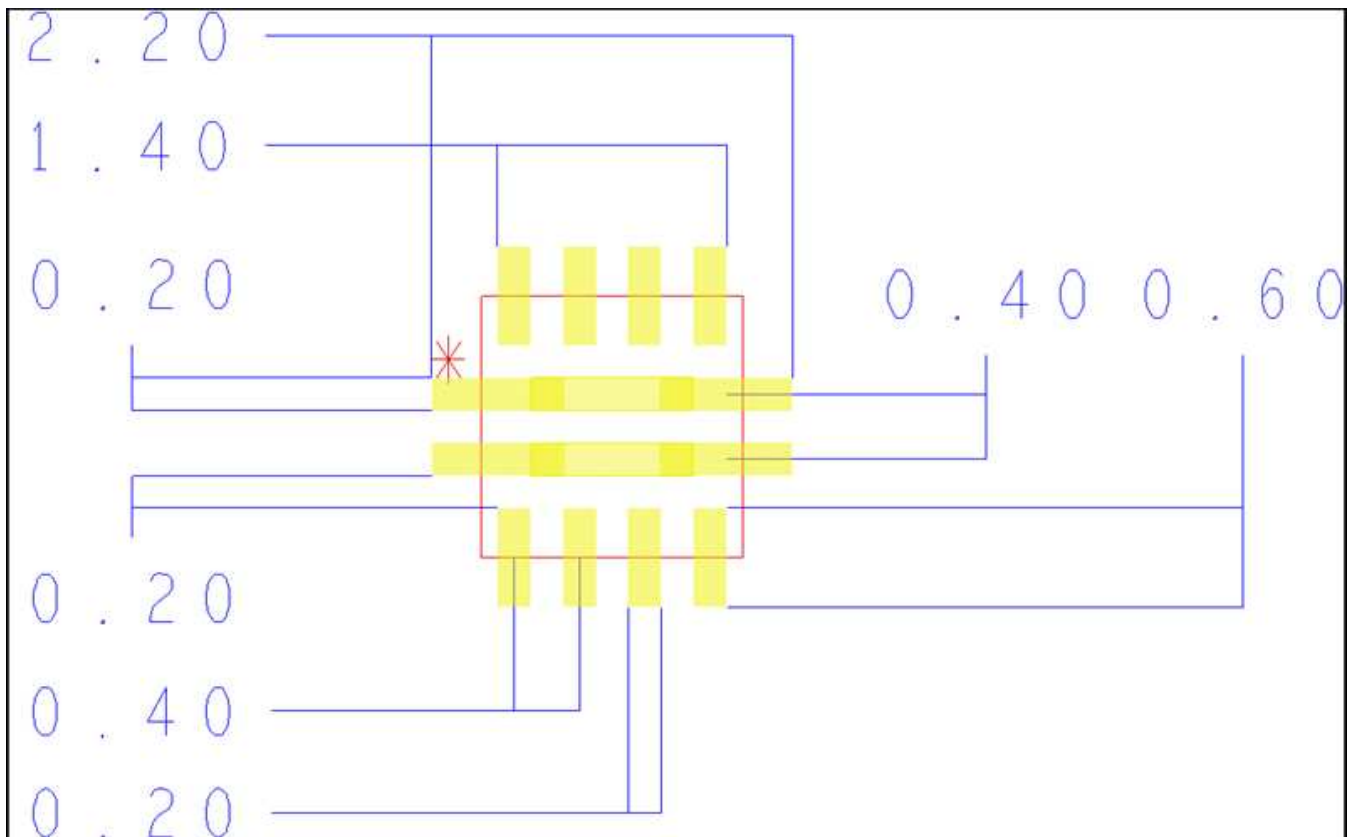

Figure 8. DP and DM Routing Underneath Device Package

11 Device and Documentation Support

11.1 Related Links

The table below lists quick access links. Categories include technical documents, support and community resources, tools and software, and quick access to order now.

Table 2. Related Links

PARTS	PRODUCT FOLDER	ORDER NOW	TECHNICAL DOCUMENTS	TOOLS & SOFTWARE	SUPPORT & COMMUNITY
TUSB211	Click here	Click here	Click here	Click here	Click here
TUSB211I	Click here	Click here	Click here	Click here	Click here

11.2 Community Resources

The following links connect to TI community resources. Linked contents are provided "AS IS" by the respective contributors. They do not constitute TI specifications and do not necessarily reflect TI's views; see TI's [Terms of Use](#).

TI E2E™ Online Community *TI's Engineer-to-Engineer (E2E) Community*. Created to foster collaboration among engineers. At e2e.ti.com, you can ask questions, share knowledge, explore ideas and help solve problems with fellow engineers.

Design Support *TI's Design Support* Quickly find helpful E2E forums along with design support tools and contact information for technical support.

11.3 Trademarks

E2E is a trademark of Texas Instruments.
All other trademarks are the property of their respective owners.

11.4 Electrostatic Discharge Caution



These devices have limited built-in ESD protection. The leads should be shorted together or the device placed in conductive foam during storage or handling to prevent electrostatic damage to the MOS gates.

11.5 Glossary

SLYZ022 — *TI Glossary*.

This glossary lists and explains terms, acronyms, and definitions.

12 Mechanical, Packaging, and Orderable Information

The following pages include mechanical, packaging, and orderable information. This information is the most current data available for the designated devices. This data is subject to change without notice and revision of this document. For browser-based versions of this data sheet, refer to the left-hand navigation.

PACKAGING INFORMATION

Orderable Device	Status (1)	Package Type	Package Drawing	Pins	Package Qty	Eco Plan (2)	Lead finish/ Ball material (6)	MSL Peak Temp (3)	Op Temp (°C)	Device Marking (4/5)	Samples
TUSB2111RWBR	NRND	X2QFN	RWB	12	3000	RoHS & Green	NIPDAU	Level-2-260C-1 YEAR	-40 to 85	I1	
TUSB2111RWBR	NRND	X2QFN	RWB	12	3000	RoHS & Green	NIPDAU	Level-2-260C-1 YEAR	0 to 70	C1	

(1) The marketing status values are defined as follows:

ACTIVE: Product device recommended for new designs.

LIFEBUY: TI has announced that the device will be discontinued, and a lifetime-buy period is in effect.

NRND: Not recommended for new designs. Device is in production to support existing customers, but TI does not recommend using this part in a new design.

PREVIEW: Device has been announced but is not in production. Samples may or may not be available.

OBSOLETE: TI has discontinued the production of the device.

(2) **RoHS:** TI defines "RoHS" to mean semiconductor products that are compliant with the current EU RoHS requirements for all 10 RoHS substances, including the requirement that RoHS substance do not exceed 0.1% by weight in homogeneous materials. Where designed to be soldered at high temperatures, "RoHS" products are suitable for use in specified lead-free processes. TI may reference these types of products as "Pb-Free".

RoHS Exempt: TI defines "RoHS Exempt" to mean products that contain lead but are compliant with EU RoHS pursuant to a specific EU RoHS exemption.

Green: TI defines "Green" to mean the content of Chlorine (Cl) and Bromine (Br) based flame retardants meet JS709B low halogen requirements of <=1000ppm threshold. Antimony trioxide based flame retardants must also meet the <=1000ppm threshold requirement.

(3) MSL, Peak Temp. - The Moisture Sensitivity Level rating according to the JEDEC industry standard classifications, and peak solder temperature.

(4) There may be additional marking, which relates to the logo, the lot trace code information, or the environmental category on the device.

(5) Multiple Device Markings will be inside parentheses. Only one Device Marking contained in parentheses and separated by a "~" will appear on a device. If a line is indented then it is a continuation of the previous line and the two combined represent the entire Device Marking for that device.

(6) Lead finish/Ball material - Orderable Devices may have multiple material finish options. Finish options are separated by a vertical ruled line. Lead finish/Ball material values may wrap to two lines if the finish value exceeds the maximum column width.

Important Information and Disclaimer:The information provided on this page represents TI's knowledge and belief as of the date that it is provided. TI bases its knowledge and belief on information provided by third parties, and makes no representation or warranty as to the accuracy of such information. Efforts are underway to better integrate information from third parties. TI has taken and continues to take reasonable steps to provide representative and accurate information but may not have conducted destructive testing or chemical analysis on incoming materials and chemicals. TI and TI suppliers consider certain information to be proprietary, and thus CAS numbers and other limited information may not be available for release.

In no event shall TI's liability arising out of such information exceed the total purchase price of the TI part(s) at issue in this document sold by TI to Customer on an annual basis.

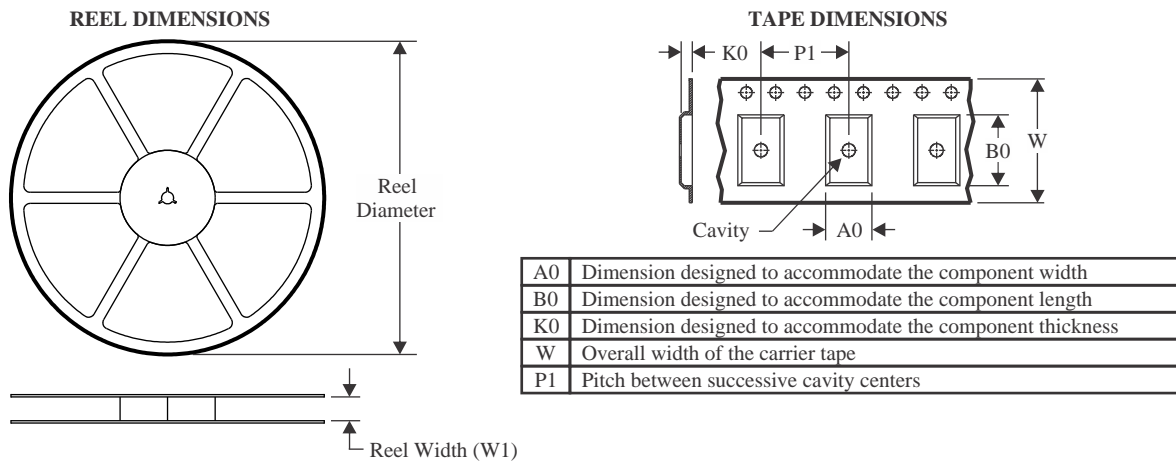
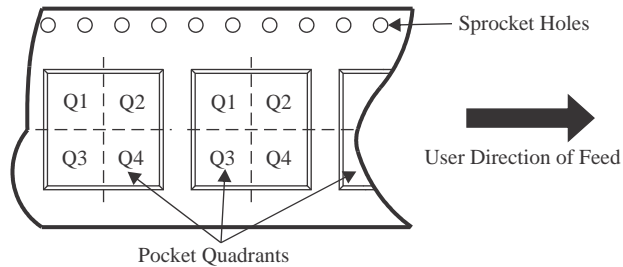
TAPE AND REEL INFORMATION

QUADRANT ASSIGNMENTS FOR PIN 1 ORIENTATION IN TAPE

*All dimensions are nominal

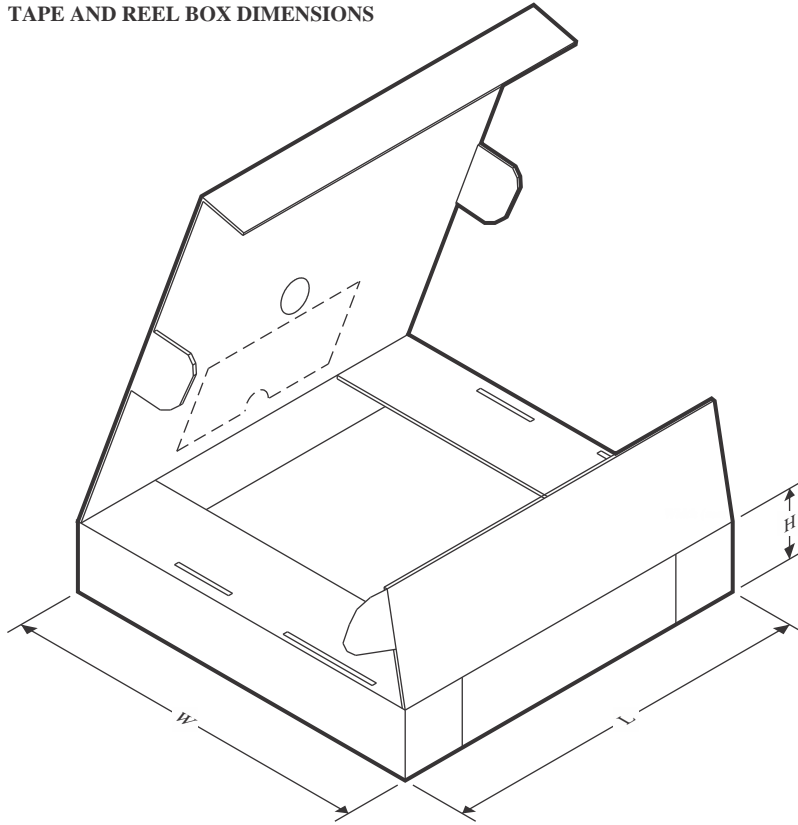
Device	Package Type	Package Drawing	Pins	SPQ	Reel Diameter (mm)	Reel Width W1 (mm)	A0 (mm)	B0 (mm)	K0 (mm)	P1 (mm)	W (mm)	Pin1 Quadrant
TUSB211RWBR	X2QFN	RWB	12	3000	180.0	8.4	1.8	1.8	0.48	4.0	8.0	Q2
TUSB211RWBR	X2QFN	RWB	12	3000	180.0	8.4	1.8	1.8	0.61	4.0	8.0	Q2
TUSB211RWBR	X2QFN	RWB	12	3000	180.0	8.4	1.8	1.8	0.48	4.0	8.0	Q2

TAPE AND REEL BOX DIMENSIONS

*All dimensions are nominal

Device	Package Type	Package Drawing	Pins	SPQ	Length (mm)	Width (mm)	Height (mm)
TUSB211IRWBR	X2QFN	RWB	12	3000	210.0	185.0	35.0
TUSB211RWBR	X2QFN	RWB	12	3000	213.0	191.0	35.0
TUSB211RWBR	X2QFN	RWB	12	3000	210.0	185.0	35.0

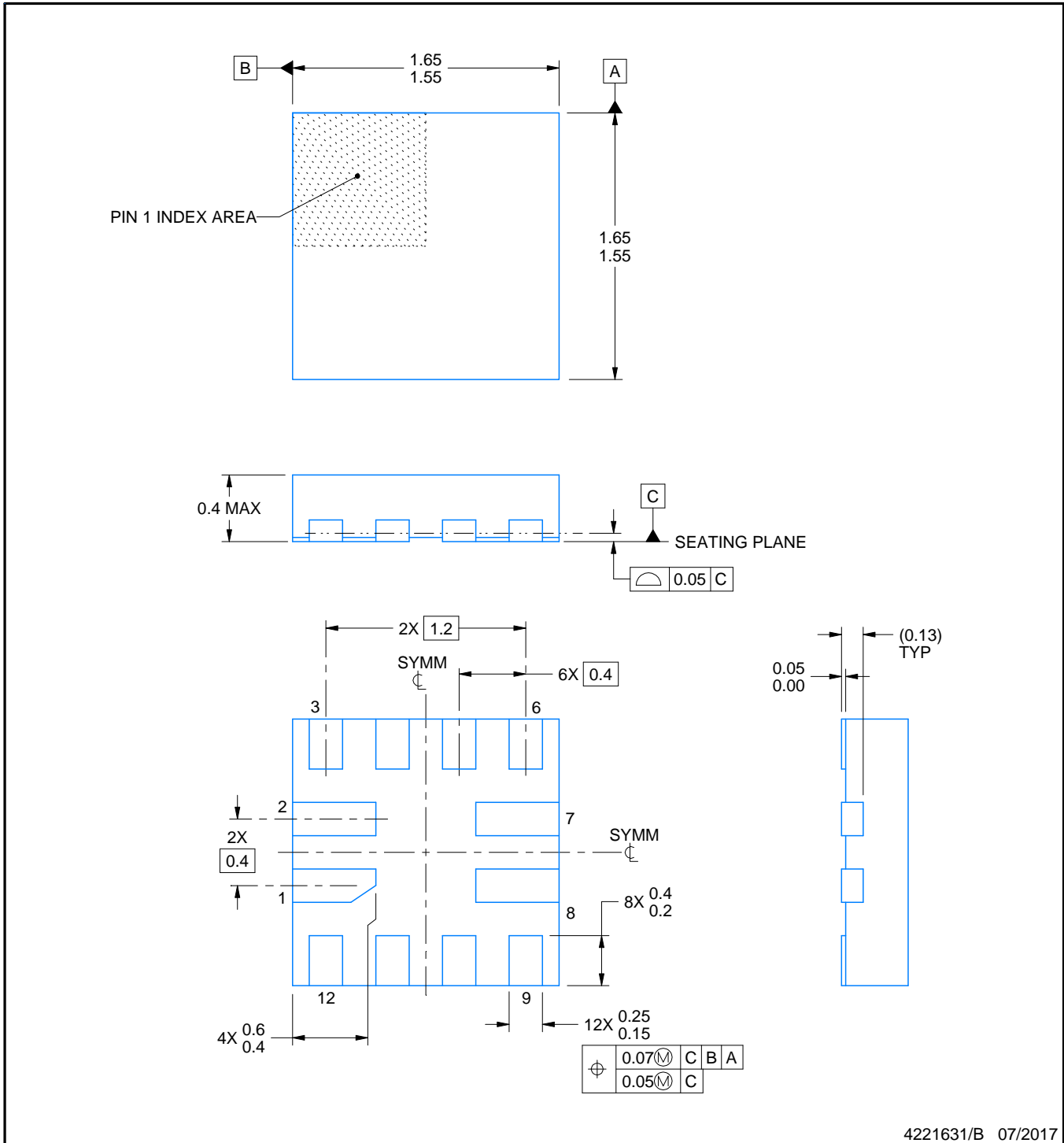
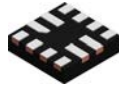

4221631/B 07/2017

NOTES:

1. All linear dimensions are in millimeters. Any dimensions in parenthesis are for reference only. Dimensioning and tolerancing per ASME Y14.5M.
2. This drawing is subject to change without notice.

EXAMPLE BOARD LAYOUT

RWB0012A

X2QFN - 0.4 mm max height

PLASTIC QUAD FLATPACK - NO LEAD

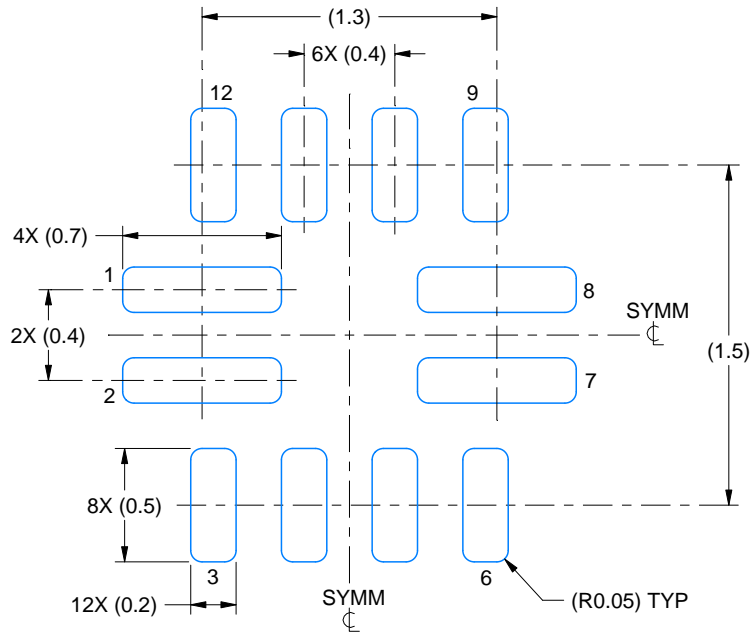

LAND PATTERN EXAMPLE
EXPOSED METAL SHOWN
SCALE:30X

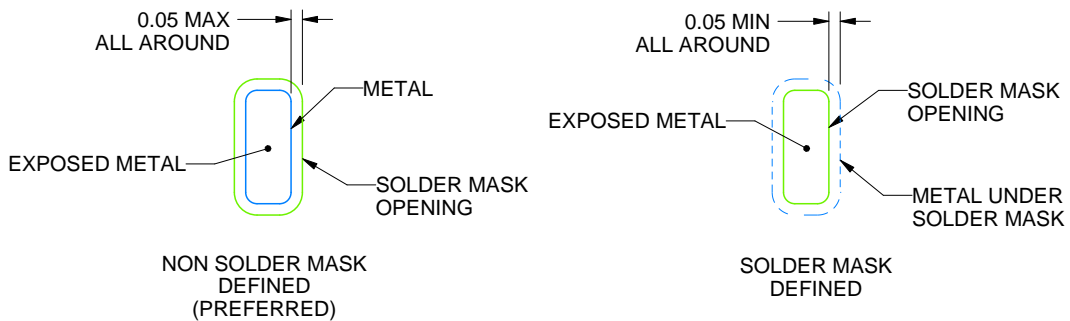

SOLDER MASK DETAILS

4221631/B 07/2017

NOTES: (continued)

3. For more information, see Texas Instruments literature number SLUA271 (www.ti.com/lit/slua271).

EXAMPLE STENCIL DESIGN

RWB0012A

X2QFN - 0.4 mm max height

PLASTIC QUAD FLATPACK - NO LEAD

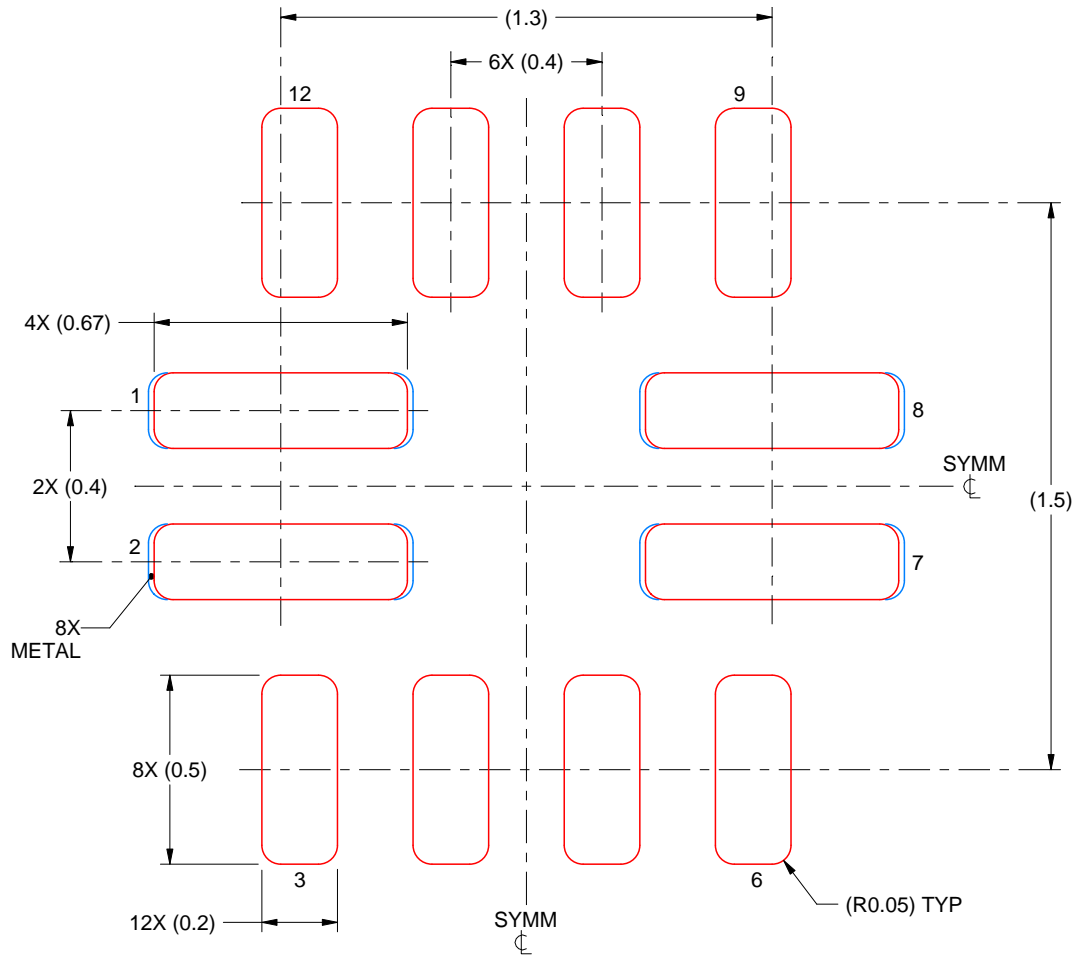

SOLDER PASTE EXAMPLE
BASED ON 0.1 mm THICK STENCIL
PADS 1,2,7 & 8
96% PRINTED SOLDER COVERAGE BY AREA
SCALE:50X

4221631/B 07/2017

NOTES: (continued)

4. Laser cutting apertures with trapezoidal walls and rounded corners may offer better paste release. IPC-7525 may have alternate design recommendations.

IMPORTANT NOTICE AND DISCLAIMER

TI PROVIDES TECHNICAL AND RELIABILITY DATA (INCLUDING DATA SHEETS), DESIGN RESOURCES (INCLUDING REFERENCE DESIGNS), APPLICATION OR OTHER DESIGN ADVICE, WEB TOOLS, SAFETY INFORMATION, AND OTHER RESOURCES "AS IS" AND WITH ALL FAULTS, AND DISCLAIMS ALL WARRANTIES, EXPRESS AND IMPLIED, INCLUDING WITHOUT LIMITATION ANY IMPLIED WARRANTIES OF MERCHANTABILITY, FITNESS FOR A PARTICULAR PURPOSE OR NON-INFRINGEMENT OF THIRD PARTY INTELLECTUAL PROPERTY RIGHTS.

These resources are intended for skilled developers designing with TI products. You are solely responsible for (1) selecting the appropriate TI products for your application, (2) designing, validating and testing your application, and (3) ensuring your application meets applicable standards, and any other safety, security, regulatory or other requirements.

These resources are subject to change without notice. TI grants you permission to use these resources only for development of an application that uses the TI products described in the resource. Other reproduction and display of these resources is prohibited. No license is granted to any other TI intellectual property right or to any third party intellectual property right. TI disclaims responsibility for, and you will fully indemnify TI and its representatives against, any claims, damages, costs, losses, and liabilities arising out of your use of these resources.

TI's products are provided subject to [TI's Terms of Sale](#) or other applicable terms available either on [ti.com](https://www.ti.com) or provided in conjunction with such TI products. TI's provision of these resources does not expand or otherwise alter TI's applicable warranties or warranty disclaimers for TI products.

TI objects to and rejects any additional or different terms you may have proposed.

Mailing Address: Texas Instruments, Post Office Box 655303, Dallas, Texas 75265
Copyright © 2024, Texas Instruments Incorporated

Looking for pricing, stock, or lifecycle information?

Click below to explore more details on WIN SOURCE:

 [View TUSB211IRWBR on WIN SOURCE](#)

 [Texas Instruments](#) Information

Optimize Your Supply Chain with WIN SOURCE Solutions

-  Global Sourcing Solution
-  Obsolete Management
-  Cost Control Management
-  Shortage Management
-  Alternative Solution
-  Excess Inventory Management