



**THE DATASHEET OF
STGB10NB40LZT4**



Automotive-grade 10 A, 410 V internally clamped IGBT

Datasheet - production data

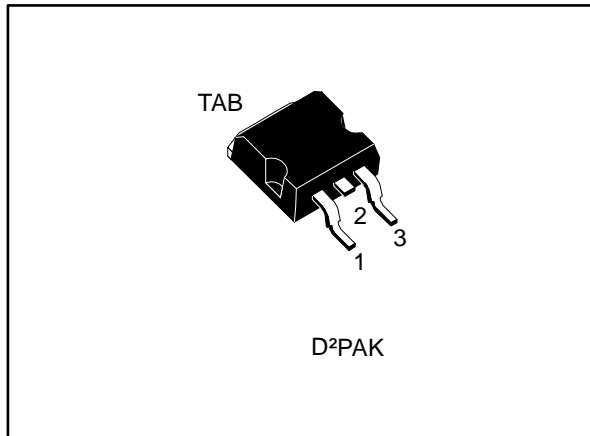
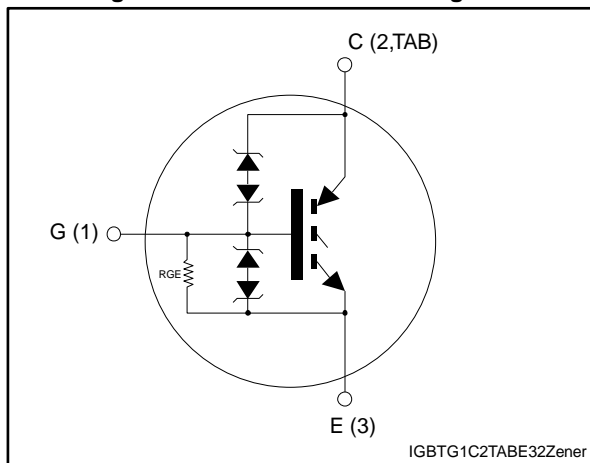

Figure 1: Internal schematic diagram



Features

Order code	V _{CES}	V _{CE(sat)} max.	I _C
STGB10NB40LZT4	Clamped	1.8 V	20 A

- AEC-Q101 qualified
- Low threshold voltage
- Low on-voltage drop
- Low gate charge
- High current capability
- High voltage clamping feature



Applications

- Switching applications

Description

Using the latest high voltage technology based on a patented strip layout, STMicroelectronics has designed an advanced family of IGBTs, PowerMESH™ with an overall outstanding performance. The built-in collector-gate Zener exhibits a very precise active clamping while the gate-emitter Zener supplies the ESD protection.

Table 1: Device summary

Order code	Marking	Package	Packing
STGB10NB40LZT4	GB10NB40LZ	D²PAK	Tape and reel

Contents

1	Electrical ratings	3
2	Electrical characteristics	4
	2.1 Electrical characteristics (curves).....	6
3	Test circuits	9
4	Package information	10
	4.1 D ² PAK (TO-263) type A package information	10
	4.2 Packing information.....	13
5	Revision history	15

1 Electrical ratings

Table 2: Absolute maximum ratings

Symbol	Parameter	Value	Unit
V_{CES}	Collector-emitter voltage ($V_{GE} = 0\text{ V}$)	$V_{CES(\text{clamped})}$	V
V_{ECS}	Emitter-collector voltage ($V_{GE} = 0\text{ V}$)	18	V
I_C	Continuous collector current at $T_C = 25\text{ °C}$	20	A
	Continuous collector current at $T_C = 100\text{ °C}$	10	A
$I_{CM}^{(1)}$	Collector current (pulsed)	40	A
E_{AS}	Single pulse energy $T_C = 25\text{ °C}$	300	mJ
V_{GE}	Gate-emitter voltage	$V_{GE(\text{clamped})}$	V
P_{TOT}	Total dissipation at $T_C = 25\text{ °C}$	150	W
ESD	Human body model, $R = 1.5\text{ k}\Omega$, $C = 100\text{ pF}$	4	kV
T_{STG}	Storage temperature range	- 55 to 175	°C
T_J	Operating junction temperature range		

Notes:

⁽¹⁾Pulse width limited by safe operating area.

Table 3: Thermal data

Symbol	Parameter	Value	Unit
R_{thJC}	Thermal resistance junction-case	1	°C/W
R_{thJA}	Thermal resistance junction-ambient	62.5	°C/W

2 Electrical characteristics

$T_C = 25\text{ °C}$ unless otherwise specified

Table 4: Static characteristics

Symbol	Parameter	Test conditions	Min.	Typ.	Max.	Unit
$V_{CES(\text{clamped})}$	Collector-emitter clamped voltage	$I_C = 2\text{ mA}$, $V_{GE} = 0\text{ V}$, $T_J = -40\text{ °C}$ to 150 °C	380	410	440	V
$V_{(BR)ECS}$	Emitter-collector break-down voltage	$I_C = 75\text{ mA}$, $V_{GE} = 0\text{ V}$	18			V
$V_{GE(\text{clamped})}$	Gate-emitter clamped voltage	$I_G = \pm 2\text{ mA}$	12		16	V
$V_{CE(\text{sat})}$	Collector-emitter saturation voltage	$V_{GE} = 4.5\text{ V}$, $I_C = 10\text{ A}$		1.2	1.8	V
		$V_{GE} = 4.5\text{ V}$, $I_C = 20\text{ A}$		1.3		
$V_{GE(\text{th})}$	Gate-threshold voltage	$V_{CE} = V_{GE}$, $I_C = 250\text{ }\mu\text{A}$, $T_J = -40\text{ °C}$ to 150 °C	0.6		2.2	V
I_{CES}	Collector cut-off current	$V_{CE} = 15\text{ V}$, $V_{GE} = 0\text{ V}$, $T_J = 150\text{ °C}$			10	μA
		$V_{CE} = 200\text{ V}$, $V_{GE} = 0\text{ V}$, $T_J = 150\text{ °C}$			100	μA
I_{GES}	Gate-emitter leakage current	$V_{GE} = \pm 10\text{ V}$, $V_{CE} = 0\text{ V}$			± 700	μA
R_{GE}	Gate emitter resistance			20		k Ω

Table 5: Dynamic characteristics

Symbol	Parameter	Test conditions	Min.	Typ.	Max.	Unit
g_{fs}	Forward transconductance	$V_{CE} = 15\text{ V}$, $I_C = 10\text{ A}$	-	18	-	S
C_{ies}	Input capacitance	$V_{CE} = 25\text{ V}$, $f = 1\text{ MHz}$, $V_{GE} = 0\text{ V}$	-	1300	-	pF
C_{oes}	Output capacitance		-	105	-	
C_{res}	Reverse transfer capacitance		-	12	-	
Q_g	Total gate charge	$V_{CE} = 328\text{ V}$, $I_C = 10\text{ A}$, $V_{GE} = 5\text{ V}$	-	28	-	nC

Table 6: Functional characteristics

Symbol	Parameter	Test conditions	Min.	Typ.	Max.	Unit
I_{CL}	Latching current	$V_{\text{Clamp}} = 328\text{ V}$, $T_C = 125\text{ °C}$ $R_{\text{GOFF}} = 1\text{ k}\Omega$, $V_{GE} = 5\text{ V}$		40	-	A
U.I.S.	Functional test open secondary coil	$R_{\text{GOFF}} = 1\text{ k}\Omega$, $L = 1\text{ mH}$, $T_C = 125\text{ °C}$	13		-	A

Table 7: IGBT switching characteristics (inductive load)

Symbol	Parameter	Test conditions	Min.	Typ.	Max.	Unit
$t_{d(on)}$	Turn-on delay time	$V_{CC} = 328 \text{ V}$, $I_C = 10 \text{ A}$, $R_G = 1 \text{ k}\Omega$, $V_{GE} = 5 \text{ V}$	-	1300	-	ns
t_r	Rise time		-	270	-	ns
$(di/dt)_{on}$	Turn-on current slope		-	60	-	A/ μ s
E_{on}	Turn-on switching energy	$V_{CC} = 328 \text{ V}$, $I_C = 10 \text{ A}$, $R_G = 1 \text{ k}\Omega$, $V_{GE} = 5 \text{ V}$	-	2.4	-	mJ
		$V_{CC} = 328 \text{ V}$, $I_C = 10 \text{ A}$, $R_G = 1 \text{ k}\Omega$, $V_{GE} = 5 \text{ V}$, $T_c = 125 \text{ }^\circ\text{C}$	-	2.6	-	mJ
t_c	Cross-over time	$V_{CC} = 328 \text{ V}$, $I_C = 10 \text{ A}$, $R_{GE} = 1 \text{ k}\Omega$, $V_{GE} = 5 \text{ V}$	-	3.6	-	μ s
$t_{r(Voff)}$	Off voltage rise time		-	2	-	μ s
$t_{d(off)}$	Turn-off-delay time		-	8	-	μ s
t_f	Fall time		-	1.4	-	μ s
$E_{off}^{(1)}$	Turn-off switching energy		-	5	-	mJ
t_c	Cross-over time		-	5.7	-	μ s
$t_{r(Voff)}$	Off voltage rise time	$V_{CC} = 328 \text{ V}$, $I_C = 10 \text{ A}$, $R_{GE} = 1 \text{ k}\Omega$, $V_{GE} = 5 \text{ V}$, $T_J = 125 \text{ }^\circ\text{C}$	-	2.7	-	μ s
$t_{d(off)}$	Turn-off-delay time		-	9.2	-	μ s
t_f	Fall time		-	2.8	-	μ s
$E_{off}^{(1)}$	Turn-off switching energy		-	8.7	-	mJ

Notes:

⁽¹⁾Including the tail of the collector current.

2.1 Electrical characteristics (curves)

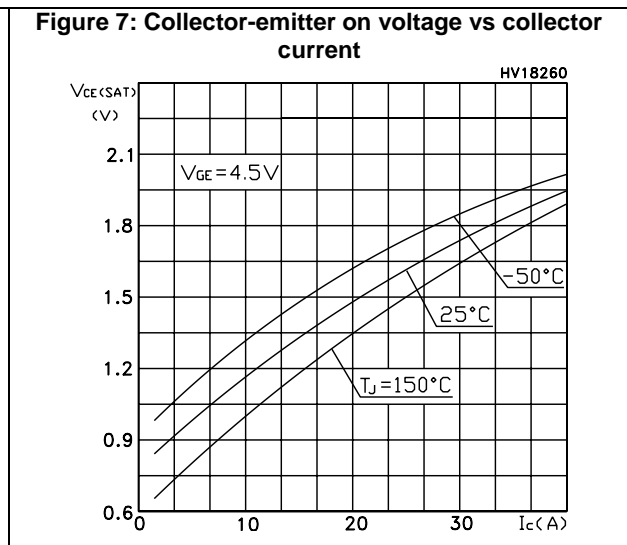
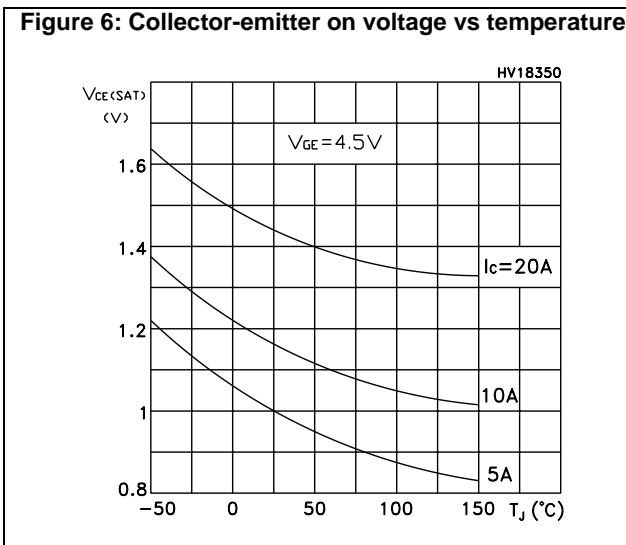
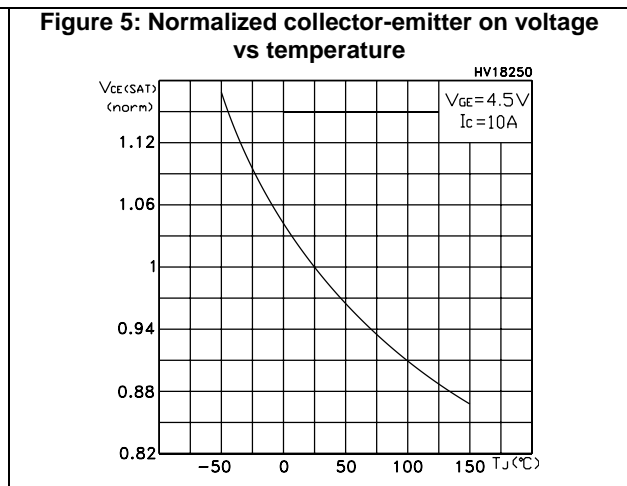
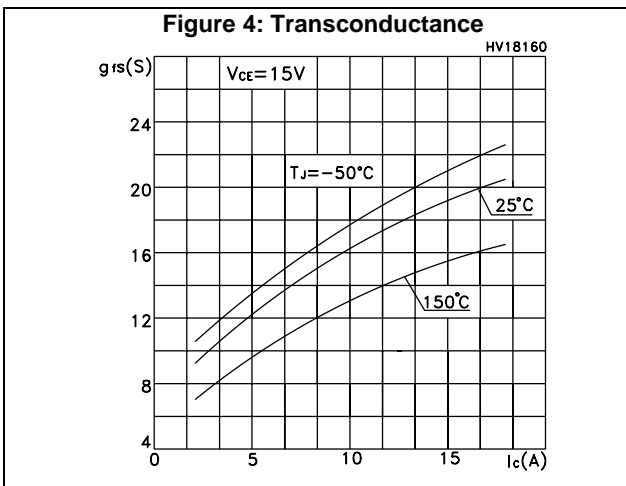
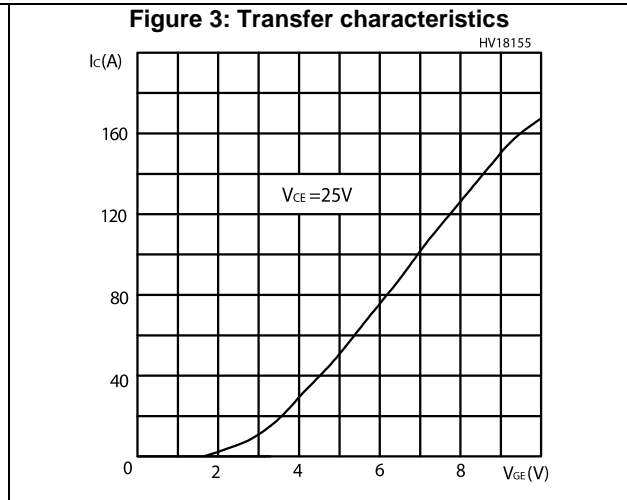
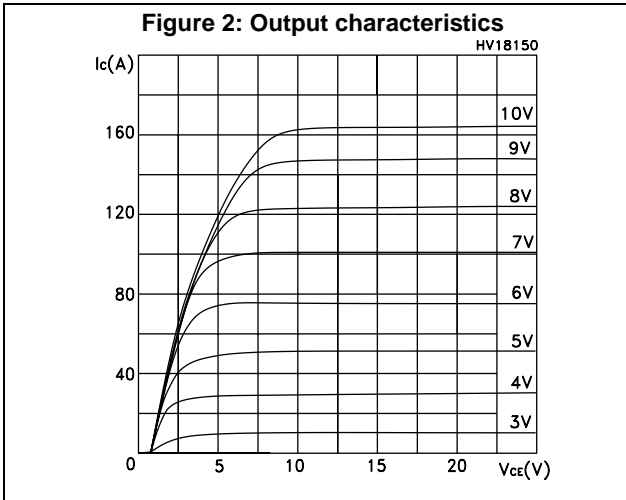

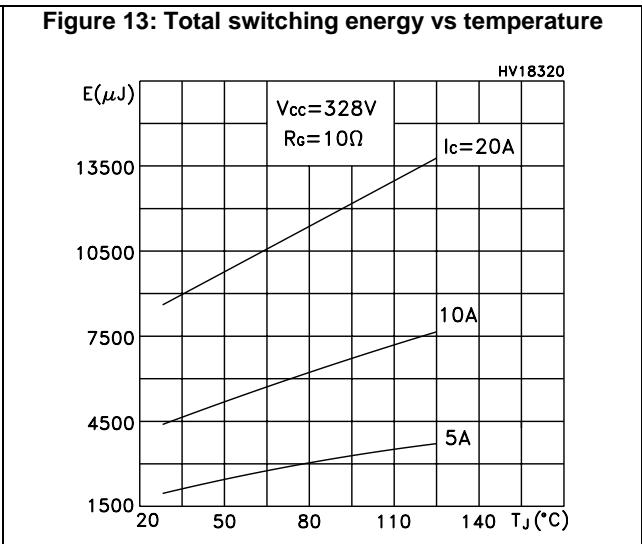
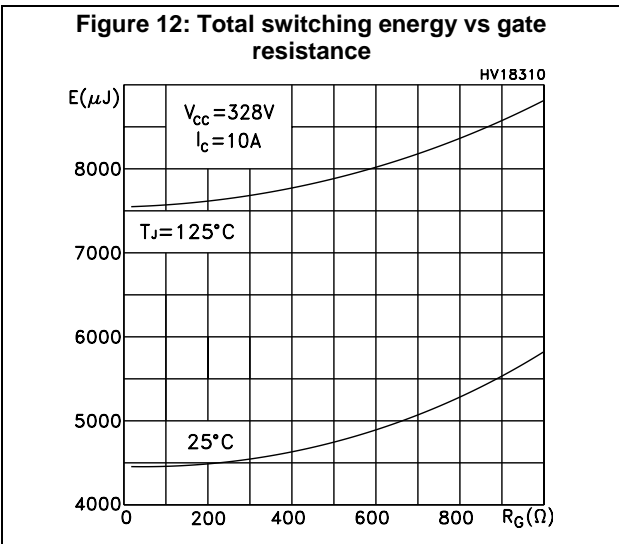
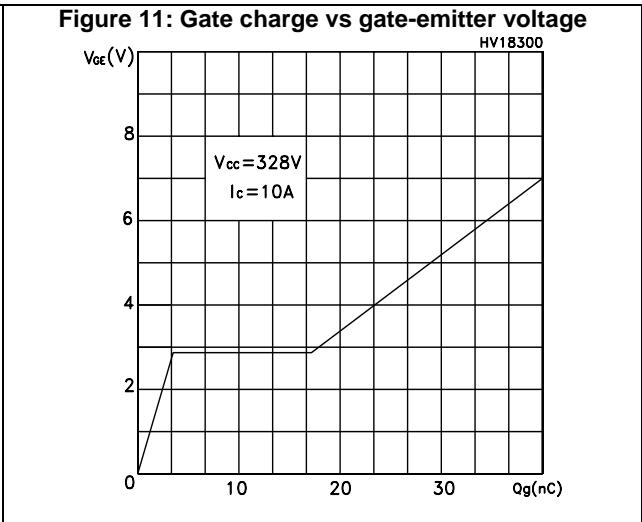
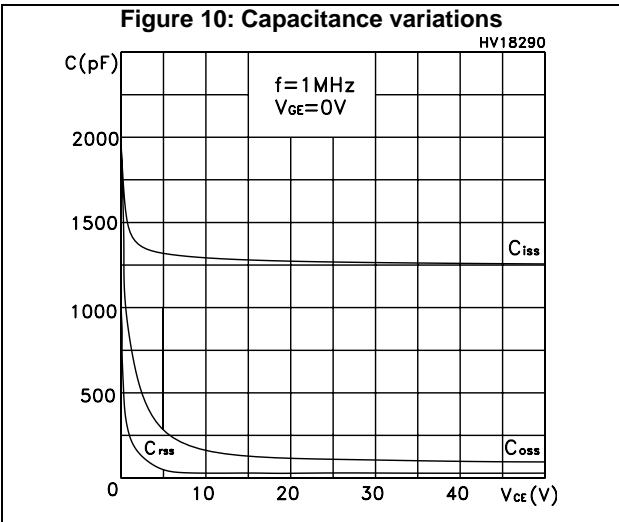
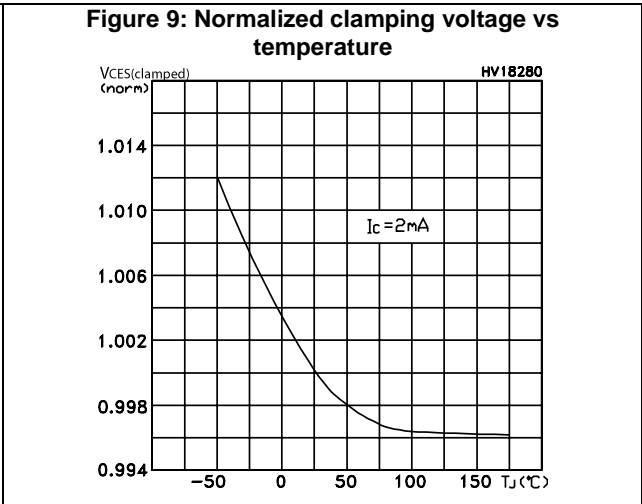
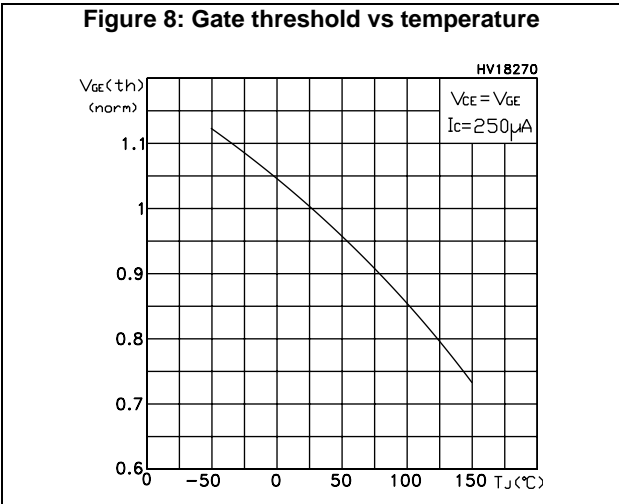

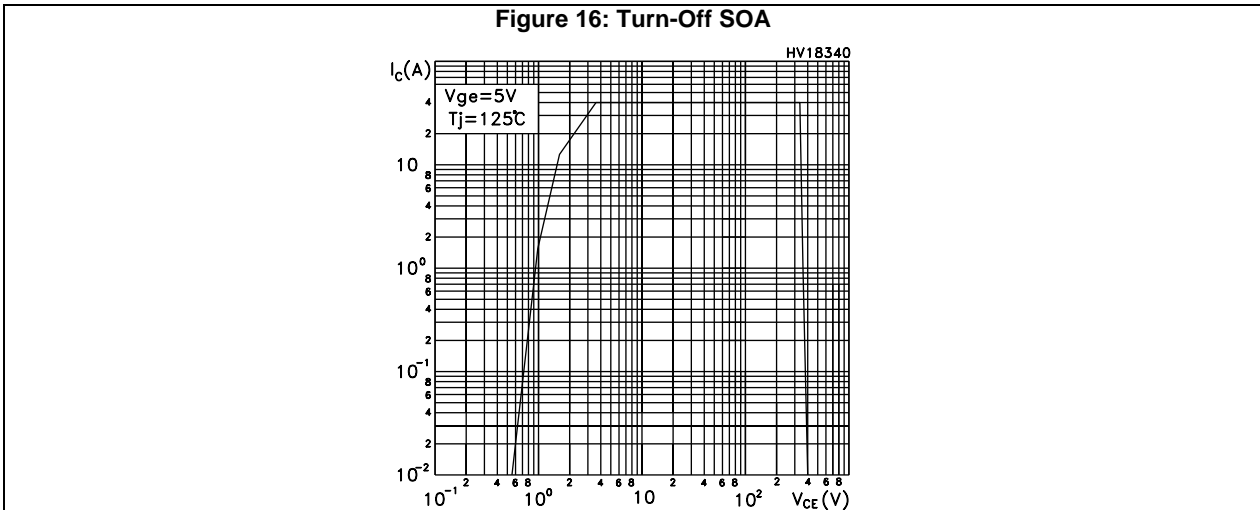
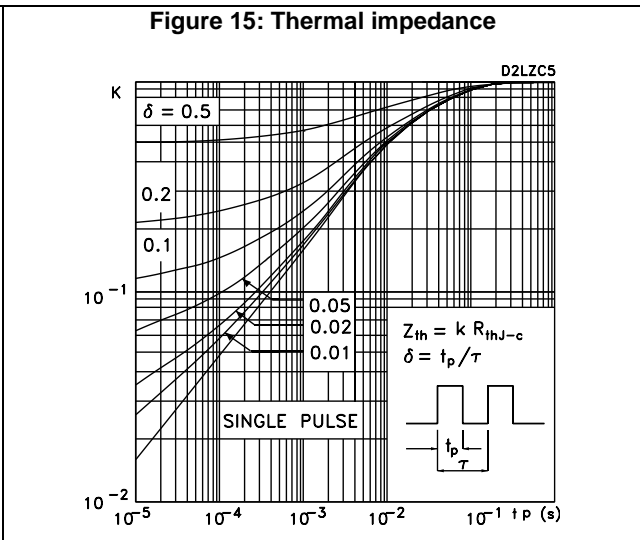
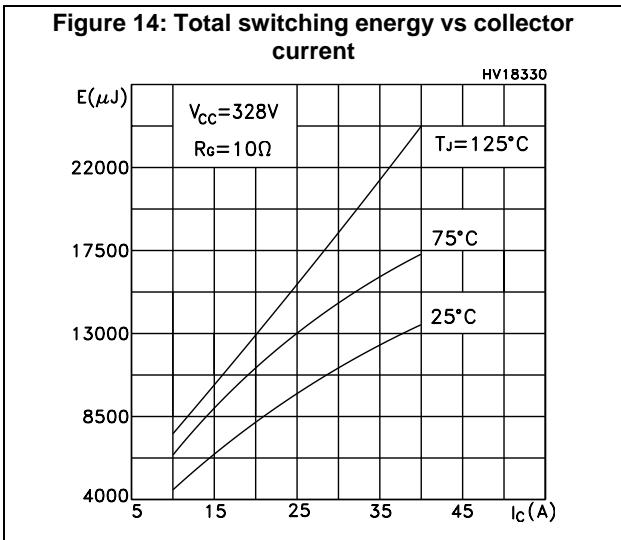

3 Test circuits

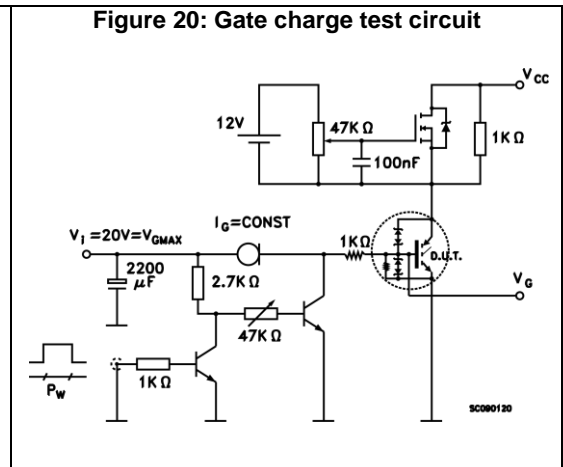
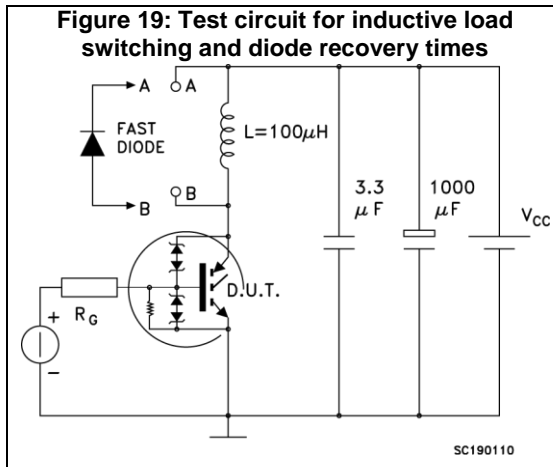
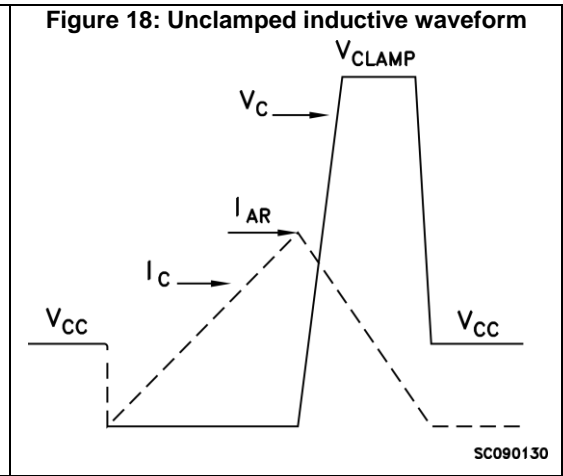
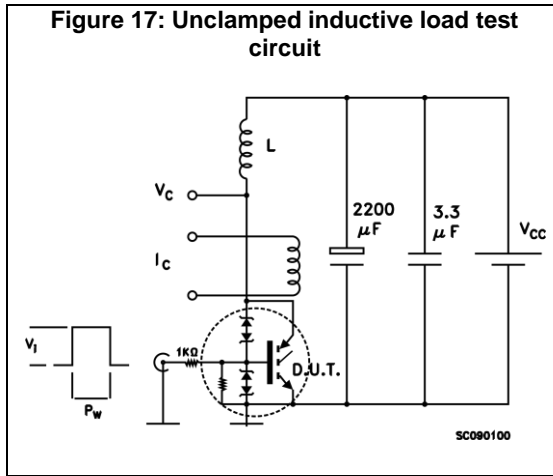

4 Package information

In order to meet environmental requirements, ST offers these devices in different grades of ECOPACK® packages, depending on their level of environmental compliance. ECOPACK® specifications, grade definitions and product status are available at: www.st.com. ECOPACK® is an ST trademark.

4.1 D²PAK (TO-263) type A package information

Figure 21: D²PAK (TO-263) type A package outline

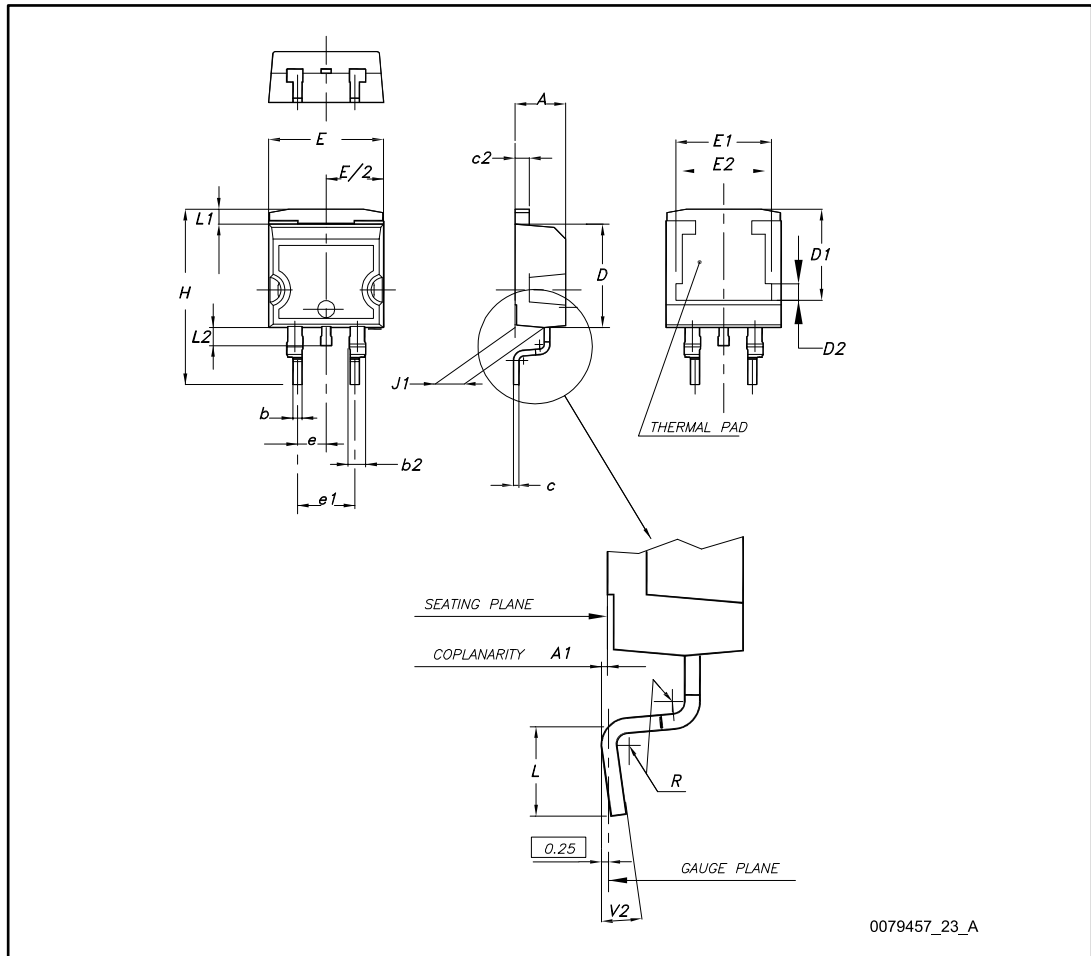
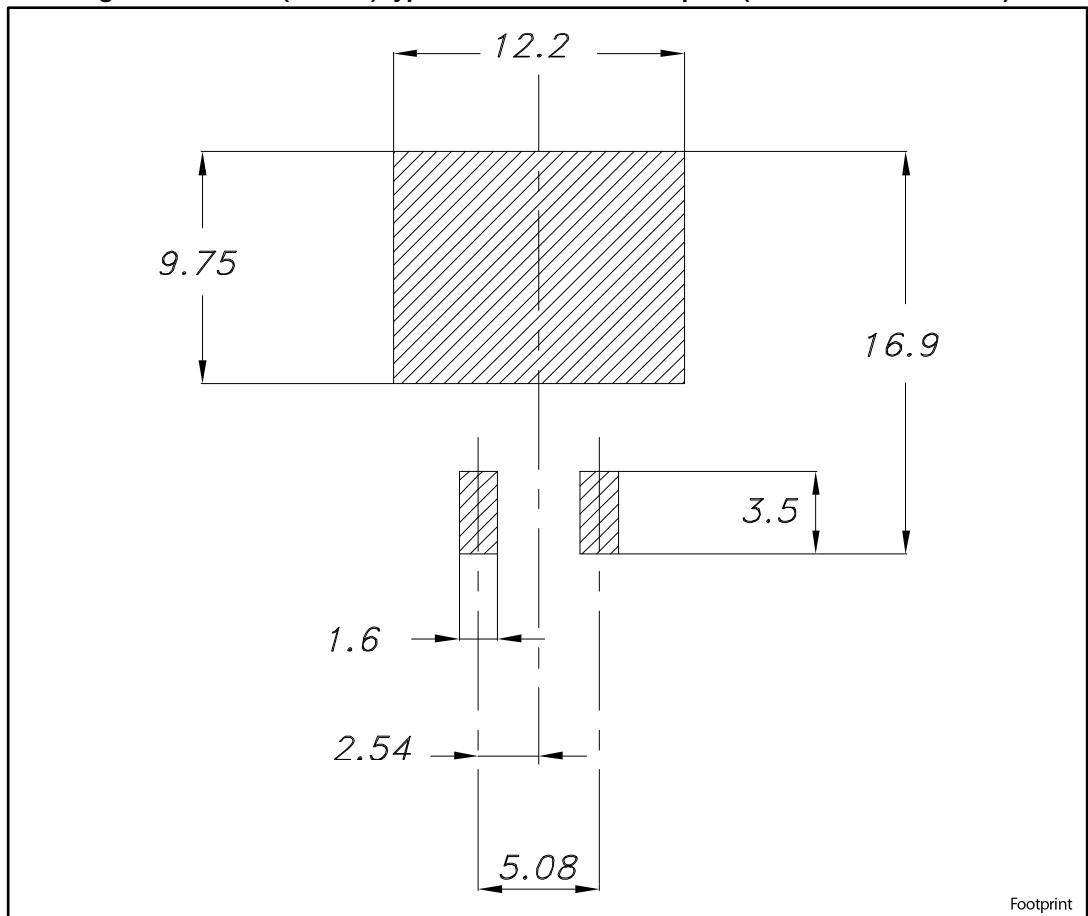

Table 8: D²PAK (TO-263) type A package mechanical data

Dim.	mm		
	Min.	Typ.	Max.
A	4.40		4.60
A1	0.03		0.23
b	0.70		0.93
b2	1.14		1.70
c	0.45		0.60
c2	1.23		1.36
D	8.95		9.35
D1	7.50	7.75	8.00
D2	1.10	1.30	1.50
E	10.00		10.40
E1	8.50	8.70	8.90
E2	6.85	7.05	7.25
e		2.54	
e1	4.88		5.28
H	15.00		15.85
J1	2.49		2.69
L	2.29		2.79
L1	1.27		1.40
L2	1.30		1.75
R		0.40	
V2	0°		8°

Figure 22: D²PAK (TO-263) type A recommended footprint (dimensions are in mm)



Footprint

4.2 Packing information

Figure 23: D2PAK type A tape outline

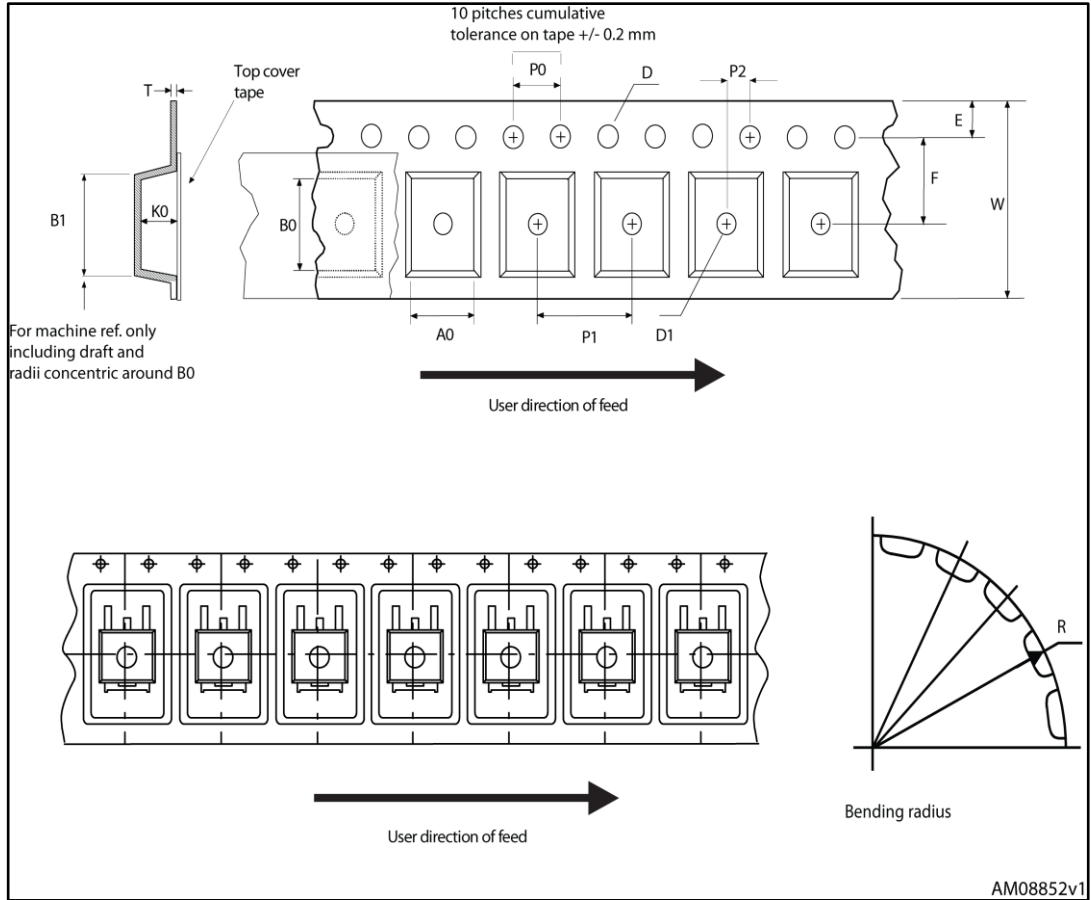

5 Revision history

Table 10: Document revision history

Date	Revision	Changes
01-Mar-2017	1	First release.

IMPORTANT NOTICE – PLEASE READ CAREFULLY

STMicroelectronics NV and its subsidiaries ("ST") reserve the right to make changes, corrections, enhancements, modifications, and improvements to ST products and/or to this document at any time without notice. Purchasers should obtain the latest relevant information on ST products before placing orders. ST products are sold pursuant to ST's terms and conditions of sale in place at the time of order acknowledgement.

Purchasers are solely responsible for the choice, selection, and use of ST products and ST assumes no liability for application assistance or the design of Purchasers' products.

No license, express or implied, to any intellectual property right is granted by ST herein.

Resale of ST products with provisions different from the information set forth herein shall void any warranty granted by ST for such product.



ST and the ST logo are trademarks of ST. All other product or service names are the property of their respective owners.

Information in this document supersedes and replaces information previously supplied in any prior versions of this document.

© 2017 STMicroelectronics – All rights reserved

Looking for pricing, stock, or lifecycle information?

Click below to explore more details on WIN SOURCE:

-  [View STGB10NB40LZT4 on WIN SOURCE](#)
-  [STMicroelectronics Information](#)

Optimize Your Supply Chain with WIN SOURCE Solutions

-  Global Sourcing Solution
-  Obsolete Management
-  Cost Control Management
-  Shortage Management
-  Alternative Solution
-  Excess Inventory Management