





THE DATASHEET OF ES1JF



SPECIFICATION SHEET

| | |
|--------------------------------|--|
| SPECIFICATION SHEET NO. | N0310-SMAFES1JF0S160 |
| DATE | Mar. 10, 2021 |
| REVISION | A0 |
| DESCRIPTION | <p>SMD Super Fast Recovery Rectifier, SMAF series, ES1JF Type, 2 Pads</p> <p>Reverse recovery Time 35 ns Max.</p> <p>Reverse Voltage 600V Max. Forward Current 1.0A Max.</p> <p>Operating Temp. Range -55°C ~+150°C</p> <p>Package in Tape/Reel, 2000pcs/Reel</p> <p>RoHS/RoHS III compliant</p> |
| CUSTOMER | |
| CUSTOMER PART NUMBER | |
| CROSS REF. PART NUMBER | |
| ORIGINAL PART NUMBER | MDD ES1JF |
| PART CODE | SMAFES1JF0S160 |

| | | | |
|-------------------------|---|--|---|
| VENDOR APPROVE | | | |
| Issued/Checked/Approved |  |  |  |
| DATE: March 10, 2021 | | | |

| |
|-------------------------|
| CUSTOMER APPROVE |
| |
| DATE: |

SMD SUPER FAST RECOVERY RECTIFIER SMAF SERIES

MAIN FEATURE



- The plastic package carries Underwriters Laboratory Flammability Classification 94V-0
- Low reverse leakage
- Built-in strain relief
- High forward surge current capability
- High temperature soldering guaranteed: 250°C/ 10 seconds at terminals
- Glass passivated chip junction

APPLICATION

- For SMD application

RFQ

[Request For Quotation](#)

PART CODE GUIDE

| SMAF | ES1JFO | S | 160 |
|------|--------|---|-----|
| 1 | 2 | 3 | 4 |

- 1) **SMAF**: SMD Super Fast Recovery Rectifier, SMAF series code
- 2) **ES1JFO**: Type code for ES1JF
- 3) **S**: Package code, Tape/reel, 2000pcs/reel.
- 4) **160**: Specification code for Forward Current 1.0A Max. Reverse Voltage 600V Max.

MORE ITEMS AVAILABLE

| | | | | |
|----------------|-----------------------|----------------|----------------|----------------|
| SMAFES1AF0S105 | SMAFES1BF0S110 | SMAFES1CF0S115 | SMAFES1DF0S120 | SMAFES1EF0S130 |
| SMAFES1GF0S140 | SMAFES1JF0S160 | | | |
| SMAFES2AF0S205 | SMAFES2BF0S210 | SMAFES2CF0S215 | SMAFES2DF0S220 | SMAFES2EF0S230 |
| SMAFES2GF0S240 | SMAFES2JF0S260 | | | |
| SMAFES3AF0S305 | SMAFES3BF0S310 | SMAFES3CF0S315 | SMAFES3DF0S320 | SMAFES3EF0S330 |
| SMAFES3GF0S340 | SMAFES3JF0S360 | | | |
| | | | | |

SMD SUPER FAST RECOVERY RECTIFIER SMAF SERIES

DIMENSION (Unit: Inch/mm)

Image for reference



Marking: ES1JF

SMAF

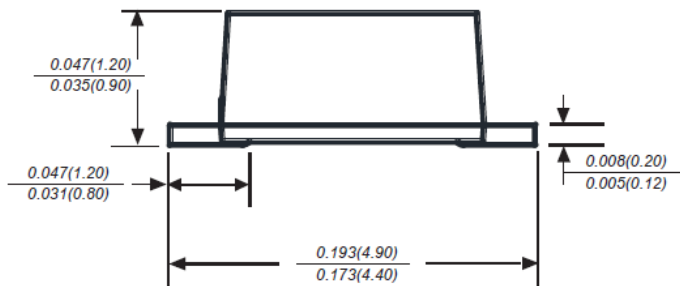
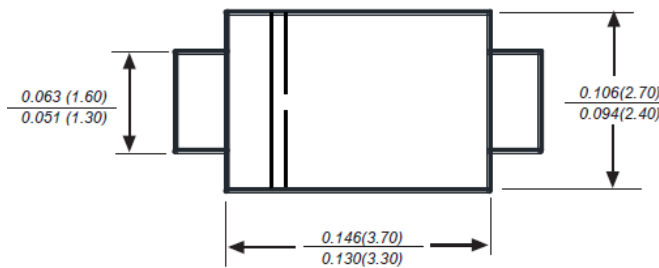

Recommend Pad Layout

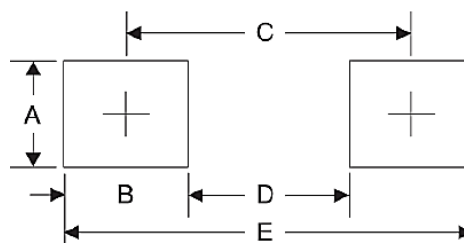

| Symbol | Unit (Inch) | Unit (mm) |
|--------|-------------|-----------|
| A | 0.071 | 1.80 |
| B | 0.063 | 1.60 |
| C | 0.150 | 3.80 |
| D | 0.087 | 2.21 |
| E | 0.213 | 5.40 |

SMD SUPER FAST RECOVERY RECTIFIER SMAF SERIES
MECHANICAL DATA

| Case | Terminals | Polarity | Mounting Position | Weight per piece |
|--------------------------------|--|--------------------------------|-------------------|----------------------------|
| JEDEC SMAF molded plastic body | Solder plated, Solderable per MIL-STD-750, Method 2026 | Color band denotes cathode end | Any | 0.0018 Ounce, 0.0510 grams |

MAX. RATING & CHARACTERISTICS

| Parameter | SYMBOLS | VALUE | | | UNITS |
|--|------------------|----------|---------|------|-------|
| | | Min. | Typical | Max. | |
| Repetitive peak reverse voltage | V _{RRM} | | | 600 | Volts |
| RMS voltage | V _{RMS} | | | 420 | Volts |
| DC blocking voltage | V _{DC} | | | 600 | Volts |
| Average forward output rectified current at TL= 55°C | I _{AV} | | | 1.0 | A |
| Peak forward surge current 8.3ms single half sine-wave superimposed on rated load (JEDEC Method) | I _{FSM} | | 30 | | A |
| Instantaneous forward voltage at 1.0A | V _F | | | 1.70 | Volts |
| DC reverse current at rated DC blocking voltage | I _R | TA=25°C | | 5 | μA |
| | | TA=125°C | | 50 | μA |
| Reverse recovery Time (Note 2) | t _{rr} | | | 35 | ns |
| Junction capacitance (NOTE 3) | C _J | | 15 | | pF |
| Thermal resistance (Note 4) | R _{QJA} | | 60 | | °C/W |
| Operating junction temperature range | T _J | -55 | | +150 | °C |
| Storage temperature range | T _{STG} | -55 | | +150 | °C |

Note

- Ratings at 25 C ambient temperature unless otherwise specified. Single phase half-wave 60Hz, resistive or inductive load, for capacitive load current derate by 20%.
- Reverse recovery condition IF=0.5A,IR=1.0A,Irr=0.25A
- Measured at 1.0MHz and applied reverse voltage of 4.0Voltage
- P.C.B. mounted with 0.2x0.2"(5.0x5.0mm) copper pad areas.

SMD SUPER FAST RECOVERY RECTIFIER SMAF SERIES
RELIABILITY

| Number | Experiment Items | Experiment Method And Conditions | Reference Documents |
|--------|------------------------------------|--|---------------------------------|
| 1 | Solder Resistance Test | Test 260°C± 5°C for 10 ± 2 sec. Immerse body into solder 1/16" ± 1/32" | MIL-STD-750D METHOD-2031.2 |
| 2 | Solderability Test | 230°C ±5°C for 5 sec. | MIL-STD-750D METHOD-2026.1 0 |
| 3 | Pull Test | 1 kg in axial lead direction for 10 sec. | MIL-STD-750D METHOD-2036.4 |
| 4 | Bend Test | 0.5Kg Weight Applied To Each Lead, Bending Arcs 90 °C ± 5 °C For 3 Times | MIL-STD-750D METHOD-2036.4 |
| 5 | High Temperature Reverse Bias Test | TA=100°C for 1000 Hours at VR=80% Rated VR | MIL-STD-750D METHOD-1038.4 |
| 6 | Forward Operation Life Test | TA=25°C Rated Average Rectified Current | MIL-STD-750D METHOD-1027.3 |
| 7 | Intermittent Operation Life Test | On state: 5 min with rated IRMS Power Off state: 5 min with Cool Forced Air. On and off for 1000 cycles. | MIL-STD-750D METHOD-1036.3 |
| 8 | Pressure Cooker Test | 15 PSIG, TA=121°C, 4 hours | MIL-S-19500 APPENOIXC |
| 9 | Temperature Cycling Test | -55°C~+125°C; 30 Minutes For Dwelled Time 5 minutes for transferred time. Total: 10 cycles. | MIL-STD-750D METHOD-1051.7 |
| 10 | Thermal Shock Test | 0°C for 5 minutes., 100°C for 5minutes, Total: 10 cycles | MIL-STD-750D METHOD-1056.7 |
| 11 | Forward Surge Test | 8.3ms Single Sale Sine-wave One Surge. | MIL-STD-750D METHOD-4066.4 |
| 12 | Humidity Test | TA=65°C, RH=98% for 1000 hours. | MIL-STD-750D METHOD-1021.3 |
| 13 | High Temperature Storage life Test | 150°C for 1000 Hours | MIL-STD-750D METHOD-1031.5 |

SMD SUPER FAST RECOVERY RECTIFIER SMAF SERIES

SUGGESTED REFLOW PROFILE (For Reference Only)

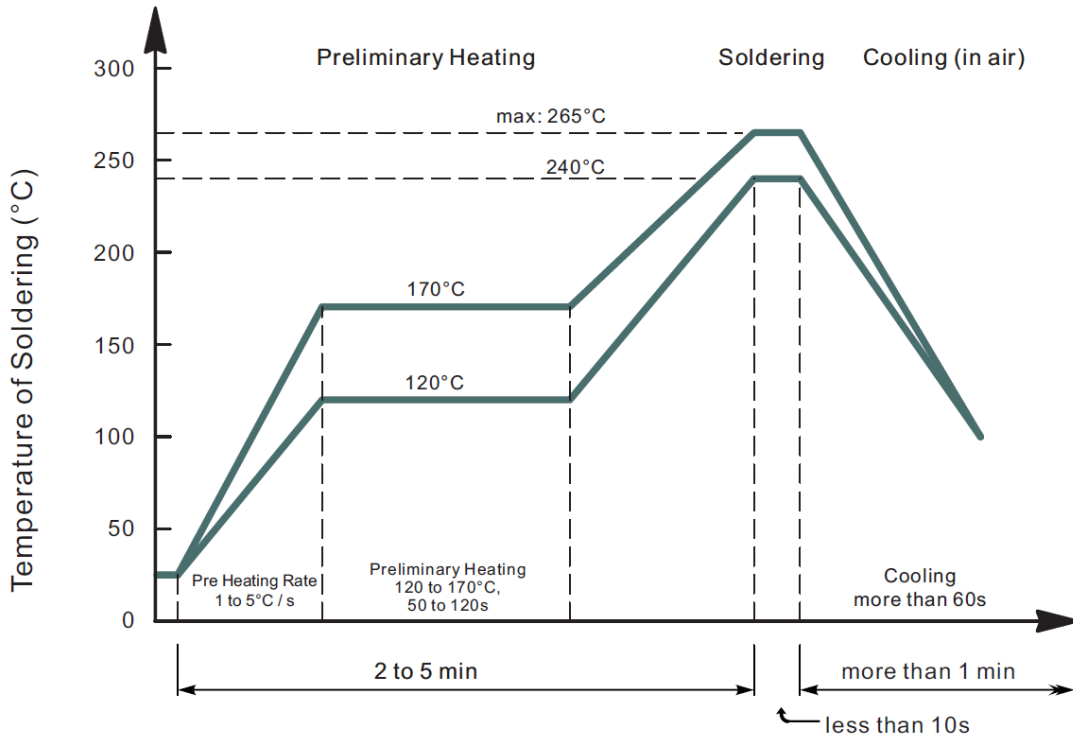

- Recommended peak temperature is over 245°C, If peak temperature is below 245 °C, you may adjust the following parameters; time length of peak temperature (longer), time length of soldering (longer), thickness of solder paste (thicker)
- Welding shall not exceed 2 times
- Remark: lead free solder paste (96.5 sn/3.0 Ag/0.5Cu)

SMD SUPER FAST RECOVERY RECTIFIER SMAF SERIES

RATINGS AND CHARACTERISTIC CURVES (For Reference Only)

AVERAGE FORWARD RECTIFIED CURRENT, AMPERES

FIG. 1- FORWARD CURRENT DERATING CURVE

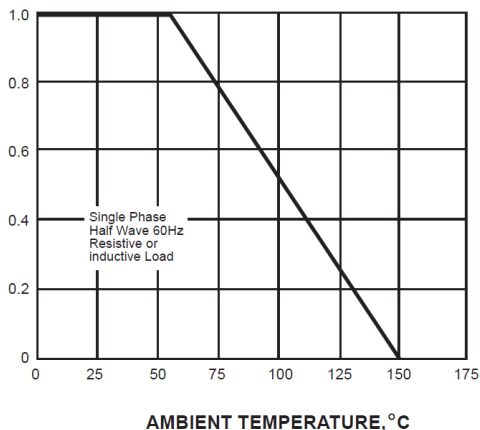

PEAK FORWARD SURGE CURRENT, AMPERES

FIG. 2-MAXIMUM NON-REPETITIVE PEAK FORWARD SURGE CURRENT

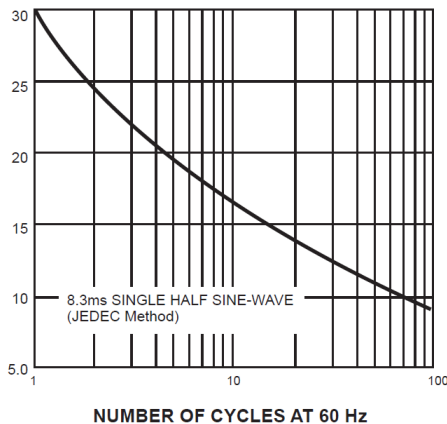

INSTANTANEOUS FORWARD CURRENT, AMPERES

FIG. 3-TYPICAL INSTANTANEOUS FORWARD CHARACTERISTICS

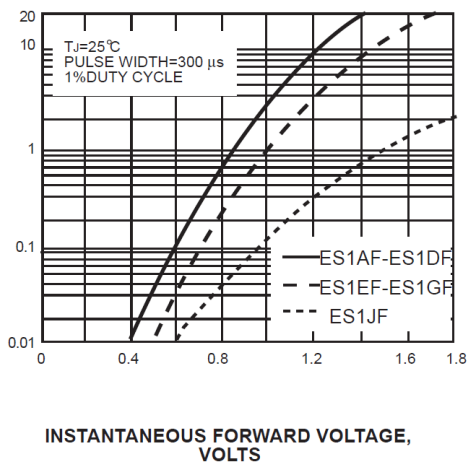

INSTANTANEOUS REVERSE CURRENT, MICROAMPERES

FIG. 4-TYPICAL REVERSE CHARACTERISTICS

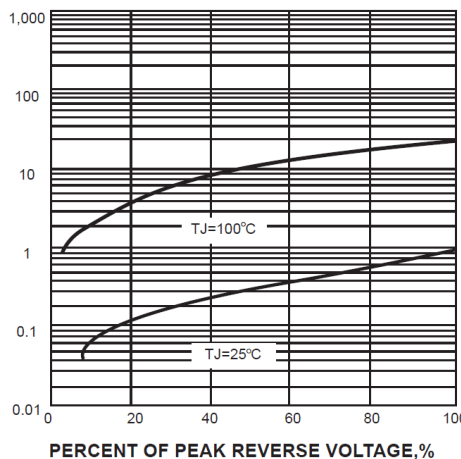

JUNCTION CAPACITANCE, pF

FIG. 5-TYPICAL JUNCTION CAPACITANCE

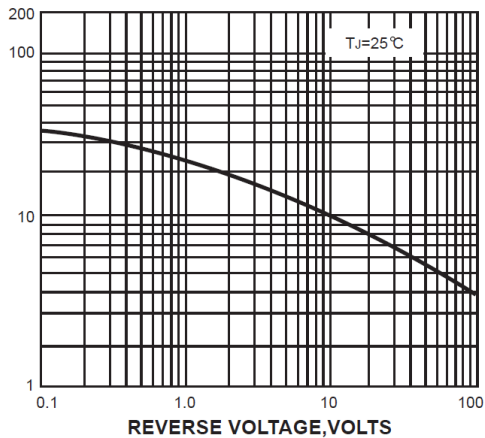

TRANSIENT THERMAL IMPEDANCE, °C/W

FIG. 6-TYPICAL TRANSIENT THERMAL IMPEDANCE

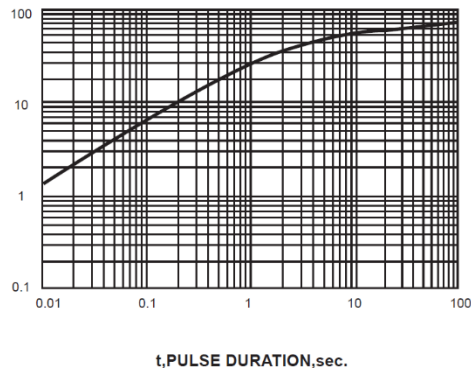

SMD SUPER FAST RECOVERY RECTIFIER SMAF SERIES

PACKAGE

| Case Code | Reel Size | MPQ (pcs) | Component Spacing (mm) | Qty. Per Box (pcs) | Inner Box L*W*H (mm) | Reel Size (mm) | Carton size L*W*H (mm) | Qty. Per Carton (pcs) | G. W (kg) |
|-----------|-----------|-----------|------------------------|--------------------|----------------------|----------------|------------------------|-----------------------|-----------|
| SMAF | 7" | 3,000 | | 6,000 | 210*208*203 | 178 | 400*400*250 | 120,000 | 10.0 |
| | | | | | | | | | |
| | | | | | | | | | |

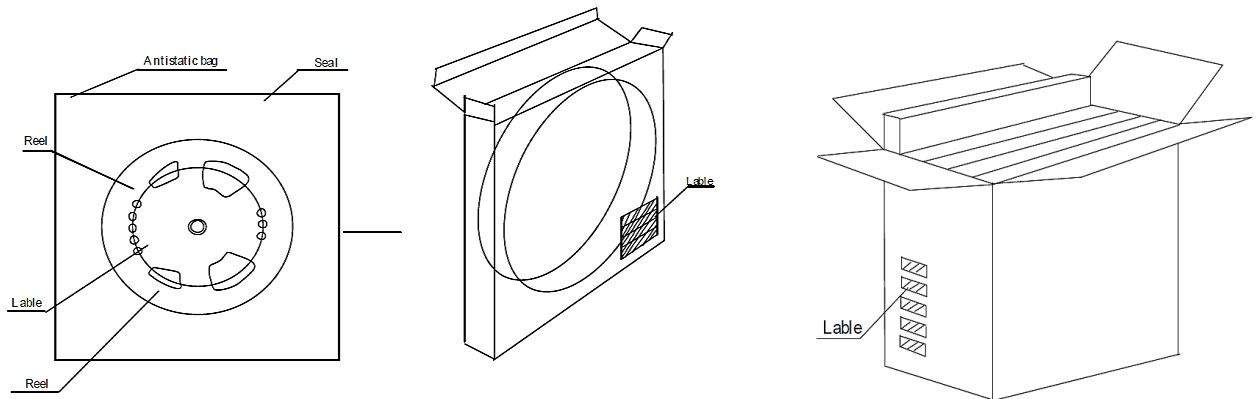

DISCLAIMER

NextGen Component, Inc. reserves the right to make changes to the product(s) and or information contained herein without notice. No liability is assumed as a result of their use or application. No rights under any patent accompany the sale of any such product(s) or information





Looking for pricing, stock, or lifecycle information?

Click below to explore more details on WIN SOURCE:

 [View ES1JF on WIN SOURCE](#)

 [MDD Information](#)

Optimize Your Supply Chain with WIN SOURCE Solutions

-  Global Sourcing Solution
-  Obsolete Management
-  Cost Control Management
-  Shortage Management
-  Alternative Solution
-  Excess Inventory Management