



**THE DATASHEET OF
ADP5588ACPZ-R7**



FEATURES

- 18-GPIO port expander or 10 × 8 keypad matrix**
- GPIOs configurable to GPIs, GPOs, and keypad rows or columns**
- Dual light sensor inputs (C8 and C9)**
- I²C interface**
- I²C register read autoincrement**
- 1.8 V to 3.0 V operation**
- Keypad lock capability**
- Open-drain interrupt output**
- Key press and key release interrupts**
- GPI interrupt with level programmability**
- Programmable pull-ups**
- Key event counter with overflow interrupt**
- 50 μs debounce on the reset line and GPIs**
- 1 μA typical idle current, 55 μA typical polling current drain for one key press**
- Small 4 mm × 4 mm LFCSP package**

APPLICATIONS

Keypad and I/O expander designed for QWERTY type phones that require a large keypad matrix

GENERAL DESCRIPTION

The ADP5588 is an I/O port expander and keypad matrix designed for QWERTY type phones that require a large keypad matrix and expanded I/O lines. I/O expander ICs are used in mobile platforms as a solution to the limited number of GPIOs available in the main processor.

In its small 4 mm × 4 mm package, the ADP5588 contains enough power to handle all key scanning and decoding and flag the processor of key presses and releases via the I²C[®] interface and interrupt. It frees the main microprocessor from having to monitor the keypad, thereby minimizing current drain and increasing processor bandwidth. It is also equipped with a buffer/FIFO and key event counter to handle and keep track of up to 10 unprocessed key or GPI events with overflow wrap and interrupt capability.

The ADP5588 has a keylock capability with an option to trigger or not trigger an interrupt at key presses and releases. All communication to the main processor is done using one interrupt line and two I²C-compatible interface lines. The ADP5588 can be configured to have a keypad matrix of up to 8 rows × 10 columns (a maximum of 80 keys).

FUNCTIONAL BLOCK DIAGRAM

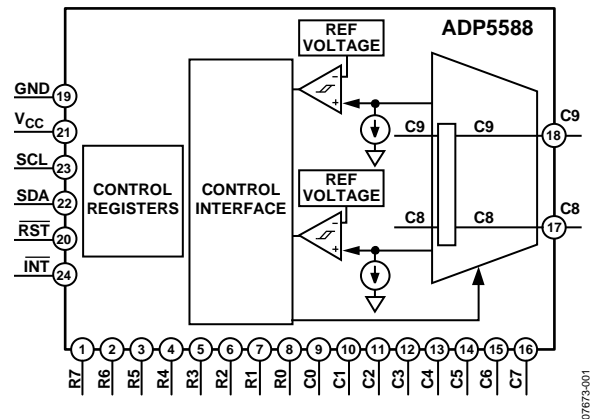

Figure 1.

When used for smaller keypad matrices, unused row and column pins can be reconfigured to act as general-purpose inputs, outputs, or light sensor inputs. R0, R1, R2, R3, R4, R5, R6, and R7 denote the row pins of the matrix, while C0, C1, C2, C3, C4, C5, C6, C7, C8, and C9 denote the column pins. At power-up, all rows and columns default as GPIs and must be programmed to function as part of the keypad matrix, GPOs, or light sensor inputs. In addition to keypad and GPIO functionalities, C8 and C9 can also be configured as light sensor inputs.

When configured as keypad lines, the function of the C8 and C9 lines is straightforward: the control interface disconnects these lines from the comparator inputs, disables the light sensor comparator, and connects them to the keypad columns of the keypad matrix. When used as light sensor comparator inputs, the control interface disconnects these pins from the keypad, enables the comparators, and connects these lines to the comparator inputs. Two external capacitors (0.1 μF) are required when these pins are configured as light sensor inputs. When used as GPIOs, these pins are removed from the keypad and the light sensor interface, and the light sensor comparators are disabled, along with the logic for the sensors.

Rev. C

Information furnished by Analog Devices is believed to be accurate and reliable. However, no responsibility is assumed by Analog Devices for its use, nor for any infringements of patents or other rights of third parties that may result from its use. Specifications subject to change without notice. No license is granted by implication or otherwise under any patent or patent rights of Analog Devices. Trademarks and registered trademarks are the property of their respective owners.

TABLE OF CONTENTS

Features	1	Keypad Operation	7
Applications	1	General-Purpose Inputs and Outputs	9
Functional Block Diagram	1	I ² C Programming and Digital Control	14
General Description	1	Registers.....	15
Revision History	2	Register Descriptions	16
Specifications.....	3	Comparator Register Descriptions	21
DC Electrical Characteristics.....	3	Applications Information	24
Absolute Maximum Ratings.....	5	Applications Overview	24
Thermal Resistance	5	Keypad Current	24
ESD Caution.....	5	Backlight Control Application.....	24
Pin Configuration and Function Descriptions.....	6	Outline Dimensions	26
Theory of Operation	7	Ordering Guide	26

REVISION HISTORY

2/12—Rev. B to Rev. C

Changes to Table 12.....	8
Changes to Table 27.....	18

4/09—Rev. A to Rev. B

Changes to Title	1
Changes to Ordering Guide	26

11/08—Rev. Sp0 to Rev. A

SPECIFICATIONS

$T_A = T_J = -40^{\circ}\text{C}$ to $+85^{\circ}\text{C}$, unless otherwise noted.

DC ELECTRICAL CHARACTERISTICS

Table 1. General DC Electrical Characteristics

Parameter	Symbol	Conditions	Min	Typ	Max	Unit
SUPPLY VOLTAGE						
VCC Input Voltage Range	V_{CC}		1.7		3.0	V
Photosensor Voltage	$V_{\text{PHOTOSENSOR}}$				$V_{CC} + 0.2$	
Supply Current ¹	I_{CC}	$V_{CC} = 1.8\text{ V to }3.0\text{ V}, T_A = -40^{\circ}\text{C to }+85^{\circ}\text{C}$		1	10	μA
With One Key Press	I_{CC}	$V_{CC} = 1.8\text{ V}, T_A = -40^{\circ}\text{C to }+85^{\circ}\text{C}$		55	90	μA
With One Key Press	I_{CC}	$V_{CC} = 3.0\text{ V}, T_A = -40^{\circ}\text{C to }+85^{\circ}\text{C}$		100	200	μA
With GPI Low (Pull-Up Enabled) ²	I_{CC}	$V_{CC} = 1.8\text{ V to }3.0\text{ V}, T_A = -40^{\circ}\text{C to }+85^{\circ}\text{C}$		20	50	μA
With GPI Low (Pull-Up Disabled)	I_{CC}	$V_{CC} = 1.8\text{ V to }3.0\text{ V}, T_A = -40^{\circ}\text{C to }+85^{\circ}\text{C}$		2	10	μA
With One GPO Active ³	I_{CC}	$V_{CC} = 1.8\text{ V}, T_A = -40^{\circ}\text{C to }+85^{\circ}\text{C}$			50	μA
AMBIENT LIGHT SENSOR (CMP_IN1, CMP_IN2)						
Maximum Sensor Range	I_{SENSOR}	$V_{CC} = 1.8\text{ V to }3.0\text{ V}, T_A = 25^{\circ}\text{C}$	0.85	1.0	1.15	mA
Sensor Supply Current (One Comparator Enabled, 0 Minimum Input Current) ⁴	I_{CC}	$V_{CC} = 1.8\text{ V to }3.0\text{ V}$		100	150	μA
Sensor Current (One Comparator Enabled, Maximum Input Current) ⁴	I_{CC}	$V_{CC} = 1.8\text{ V to }3.0\text{ V}$		160	200	μA
Sensor Current (Both Comparators Enabled, Minimum Input Current) ⁴	I_{CC}	$V_{CC} = 1.8\text{ V to }3.0\text{ V}$		130	180	μA
Sensor Current (Both Comparators Enabled, Maximum Input Current) ⁴	I_{CC}	$V_{CC} = 1.8\text{ V to }3.0\text{ V}$		240	400	μA
OSCILLATOR CURRENT						
Oscillator Current (Enabled)	I_{CC}	$V_{CC} = 1.8\text{ V to }3.0\text{ V}$		40		μA

¹ Operating current measured with I/Os defaulting as GPIOs with all pull-ups enabled and all inputs open.

² With one GPI low.

³ Load = 100 k Ω

⁴ Photosensor maximum voltage = $V_{CC} + 0.2$.

Table 2. I/O DC Electrical Characteristics

Parameter	Symbol	Conditions	Min	Typ	Max	Unit
INPUT LOGIC LEVELS (SCL, SDA, RST, C0 to C9, R0 to R7)¹						
Logic Low Input Voltage	V_{IL}	$1.7\text{ V} \leq V_{IO} \leq 3.0\text{ V}$			$0.2 \times V_{CC}$	V
Logic High Input Voltage	V_{IH}	$1.7\text{ V} \leq V_{IO} \leq 3.0\text{ V}$	$0.65 \times V_{CC}$			V
Schmitt Trigger Hysteresis	V_{HYST}			0.10		V
Input Leakage Current	$V_{\text{I-LEAKAGE}}$	$1.7\text{ V} \leq V_{IO} \leq 3.0\text{ V}$	-1		1	μA
OUTPUT LOGIC LEVELS (C0 to C9, R0 to R7)						
Logic Low Output Voltage	V_{OL}	$I_{\text{SINK}} = 1\text{ mA}$			0.40	V
Output High Voltage	V_{OH}	$I_{\text{SOURCE}} = 1\text{ mA}$		$V_{CC} - 0.3\text{ V}$		V
OUTPUT LOGIC LEVELS (INT, SDA)						
Output Low Voltage	V_{OL}	$I_{\text{SINK}} = 3\text{ mA}$ $1.7\text{ V} \leq V_{CC} \leq 3.0\text{ V}$			0.40	V
Output High Voltage	V_{OH}	$1.7\text{ V} \leq V_{CC} \leq 3.0\text{ V}$		$0.95 \times V_{CC}$		V
Logic High Leakage Current	$V_{\text{O-LEAKAGE}}$	$1.7\text{ V} \leq V_{CC} \leq 3.0\text{ V}$		0.1	1	μA
PULL-UP RESISTANCE FOR GPIOs (C0 to C9, R0 to R7) ²	$R_{\text{PULL-UP}}$			100		k Ω

¹ Power-up default current. All I/Os default as GPIOs and are open; C8 and C9 default as GPIOs; I²C is idle.

² GPIO internal pull-ups are designed to 100 k Ω .

Table 3. Comparator Input Capacitor

Parameter	Symbol	Min	Typ	Max	Unit
Comparator Input Capacitor Value	C _{COMP}		0.1		μF

Table 4. Capacitance Loading¹

Parameter	Symbol	Min	Typ	Max	Unit
I/O Input Capacitance	C _{IN}		1	10	pF
I/O Output Loading Capacitance	C _{OUT}			50	pF
Capacitive Load for Each Bus Line	C _B ²			400	pF

¹ Guaranteed by design.

² C_B = total capacitance of one bus line in picofarads.

Table 5. AC Characteristics¹

Parameter	Symbol	Min	Typ	Max	Unit
Delay from Reset Deassertion to I ² C Access	R _{STD}	60			μs
Keypad Unlock Timer	T _{KUT}		7		sec
Keypad Interrupt Mask Timer	T _{KIMT}		31		sec
Debounce	T _D		50		μs
Filter Time	T _{TTR}	0.070		12	sec

¹ Guaranteed by design.

Table 6. I²C AC Electrical Characteristics¹

Parameter	Symbol	Min	Typ	Max	Unit
SCL Clock Frequency	f _{SCL}			400	kHz
SCL High Time	t _{HIGH}	0.6			μs
SCL Low Time	t _{LOW}	1.3			μs
Data Setup Time	t _{SU, DAT}	100			ns
Data Hold Time	t _{HD, DAT}	0		0.9	μs
Setup Time for Repeated Start	t _{SU, STA}	0.6			μs
Hold Time for Start/Repeated Start	t _{HD, STA}	0.6			μs
Bus Free Time for Stop and Start	t _{BUF}	1.3			μs
Setup Time for Stop Condition	t _{SU, STO}	0.6			μs
Rise Time for SCL and SDA ²	t _R	20 + 0.1 C _B		300	ns
Fall Time for SCL and SDA ²	t _F	20 + 0.1 C _B		300	ns
Pulse Width of Suppressed Spike	t _{SP}	0		50	μs

¹ Guaranteed by design.

² t_R and t_F are measured between 0.3 × V_{CC} and 0.7 × V_{CC}.

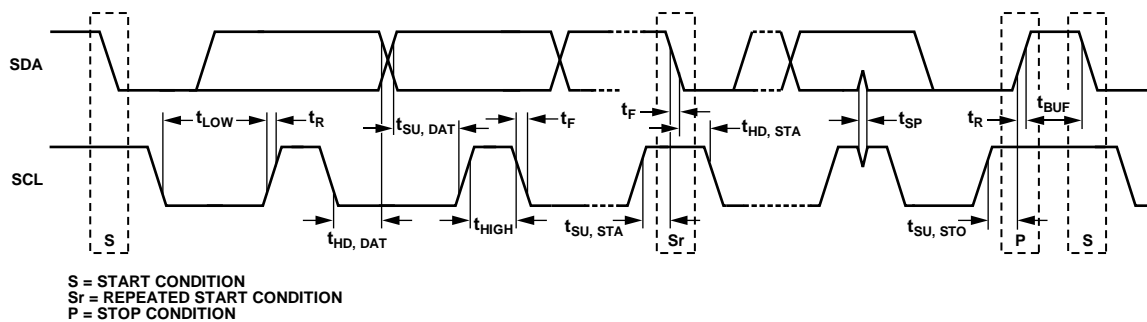

Figure 2. I²C Interface Timing Diagram

07673-002

ABSOLUTE MAXIMUM RATINGS

Table 7.

Parameter	Rating
V _{CC}	-3 V to +4.0 V
R0 to R7, C0 to C9	-3 V to V _{CC} + 0.3 V
SCL	-3 V to V _{CC} + 0.3 V
SDA	-3 V to V _{CC} + 0.3 V
RST	-3 V to V _{CC} + 0.3 V
INT	-3 V to V _{CC} + 0.3 V
GND	-0.3 V to +0.3 V
Operating Ambient Temperature Range	-40°C to +85°C
Operating Junction Temperature Range	-40°C to +125°C
Storage Temperature Range	-65°C to +150°C
ESD Machine Model	±200 V
ESD Human Body Model	±2000 V
ESD Charged Device Model	±1000 V
Soldering Condition	JEDEC J-STD-020

Stresses above those listed under Absolute Maximum Ratings may cause permanent damage to the device. This is a stress rating only; functional operation of the device at these or any other conditions above those indicated in the operational section of this specification is not implied. Exposure to absolute maximum rating conditions for extended periods may affect device reliability.

THERMAL RESISTANCE

θ_{JA} is specified for the worst-case conditions, that is, a device soldered in a circuit board for surface-mount packages.

Table 8. Thermal Resistance

Package Type	θ_{JA}	θ_{JC}	Unit
24-Lead LFCSP_VQ	57.8	9.4	°C/W
Maximum Power	600		mW

ESD CAUTION



ESD (electrostatic discharge) sensitive device. Charged devices and circuit boards can discharge without detection. Although this product features patented or proprietary protection circuitry, damage may occur on devices subjected to high energy ESD. Therefore, proper ESD precautions should be taken to avoid performance degradation or loss of functionality.

PIN CONFIGURATION AND FUNCTION DESCRIPTIONS

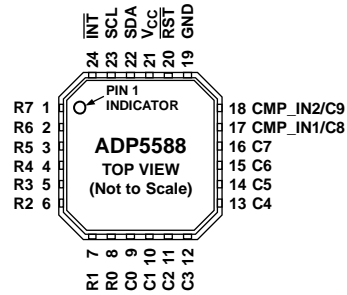

NOTES

1. NC = NO CONNECT.
2. EXPOSED PAD MUST BE CONNECTED TO GROUND.

07673-003

Figure 3. Pin Configuration

Table 9. Pin Function Descriptions

Pin No.	Mnemonic	Description
1	R7	GPIO, Row 7 in the Keypad Matrix.
2	R6	GPIO, Row 6 in the Keypad Matrix.
3	R5	GPIO, Row 5 in the Keypad Matrix.
4	R4	GPIO, Row 4 in the Keypad Matrix.
5	R3	GPIO, Row 3 in the Keypad Matrix.
6	R2	GPIO, Row 2 in the Keypad Matrix.
7	R1	GPIO, Row 1 in the Keypad Matrix.
8	R0	GPIO, Row 0 in the Keypad Matrix.
9	C0	GPIO, Column 0 in the Keypad Matrix.
10	C1	GPIO, Column 1 in the Keypad Matrix.
11	C2	GPIO, Column 2 in the Keypad Matrix.
12	C3	GPIO, Column 3 in the Keypad Matrix.
13	C4	GPIO, Column 4 in the Keypad Matrix.
14	C5	GPIO, Column 5 in the Keypad Matrix.
15	C6	GPIO, Column 6 in the Keypad Matrix.
16	C7	GPIO, Column 7 in the Keypad Matrix.
17	CMP_IN1/C8	GPIO, Column 8 in the Keypad Matrix; Comparator Input for Photosensor 1.
18	CMP_IN2/C9	GPIO, Column 9 in the Keypad Matrix; Comparator Input for Photosensor 2.
19	GND	Ground.
20	RST	Hardware Reset (Active Low). This bit resets the device to the power default conditions. The reset pin must be driven for a minimum of 50 μ s to be valid and to prevent falsing due to ESD glitches or noise in the system. If not used, RST must be tied high with a pull-up.
21	VCC	VCC = 1.7 V to 3.3 V.
22	SDA	I ² C Serial Data (Open Drain Requires External Pull-up).
23	SCL	I ² C Clock.
24	INT	Processor Interrupt, Active Low, Open Drain. This pin can be pulled up to 2.7 V or 1.8 V for selection flexibility in the processor GPIO supply group.
EP	EPAD	Exposed Pad. The exposed pad must be connected to ground.

THEORY OF OPERATION

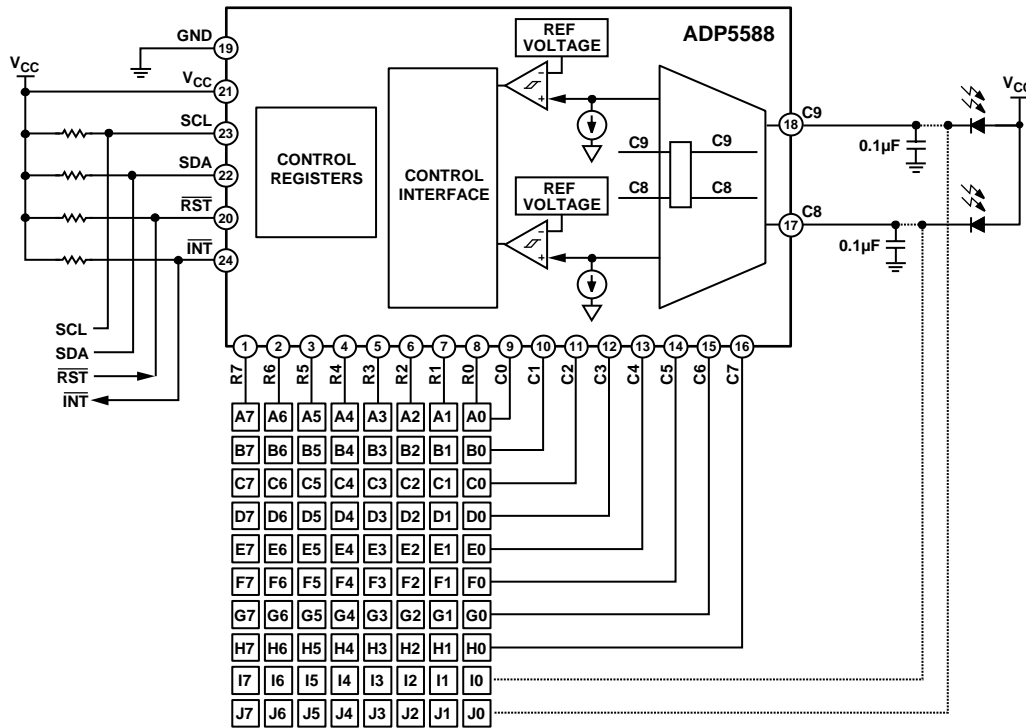

Figure 4. Typical Operating Circuit

The ADP5588 is a GPIO expander that can be configured either as an 18-I/O port expander or as a 10 column × 8 row keypad matrix (80 keys maximum). It is ideal for cellular phone designs and other portable devices that require a large extended keypad and/or expanded I/Os (see the Applications Information section for various configurations). When smaller size keypads are required, unused GPIOs in the keypad matrix can be used as I/Os (GPOs and GPIs). Two of the columns (C8 and C9) can also be configured as comparator inputs for single or dual light sensors. All GPIOs (rows and columns) default as GPIs at power-up with pull-ups and debounce enabled.

KEYPAD OPERATION

Any number of rows and columns, up to 10 columns × 8 rows, can be configured to be part of the keypad matrix. The rows and columns that make up the keypad matrix must be configured by setting the corresponding bits in Register 0x1D through Register 0x1F. Keys on the keypad matrix appear on the key event table with a decimal value of 1 (0x01 hexadecimal or 0000001 binary) and run through 80 decimals (0x50 hexadecimal or 1010000 binary). See Table 10 for key event number assignments. The keypad, in idle mode, is configured with columns being driven low and rows as inputs high with pull-ups.

Table 10. Key Event Number Assignment Table

Row	C0	C1	C2	C3	C4	C5	C6	C7	C8	C9
R0	1	2	4	4	5	6	7	8	9	10
R1	11	12	13	14	15	16	17	18	19	20
R2	21	22	23	24	25	26	27	28	29	30
R3	31	32	33	34	35	36	37	38	39	40
R4	41	42	43	44	45	46	47	48	49	50
R5	51	52	53	54	55	56	57	58	59	60
R6	61	62	63	64	65	66	67	68	69	70
R7	71	72	73	74	75	76	77	78	79	80

When one key press or multiple key presses (short between column and row) occur, the internal state machine checks the row pins to determine which one is driven low and then triggers an interrupt. The state machine then starts a key scan cycle to determine which keys are pressed. After a key has been pressed for 25 ms, the state machine sets the appropriate key(s) in the key event status register with the key-pressed bits set (the MSB in the key event register) in the order detected. If the KE_IEN field in Register 0x01 is set, the state machine then sets the KE_INT field in Register 0x01 and generates an interrupt to the host processor.

To prevent glitches or narrow press times registering as valid key presses, the key scanner requires the key to be pressed for two scan cycles. The key scanner has a sampling period of 25 ms, so the key must be pressed and held for at least 25 ms to register as pressed. If the key is continuously pressed, the key scanner continues to sample every 25 ms. If a key that was pressed is released for 25 ms or greater, the state machine sets the appropriate keys in the key event status register with the key pressed bits cleared in the order detected. Because the release of a key is not necessarily in sync with the key scan sampling period, it may take between 25 ms and 50 ms for a key to register as released. After the key is registered as released, the key scanner goes back to idle mode. Figure 5 shows the row and column pins connected to a typical 10 × 8, 80-switch keypad matrix.

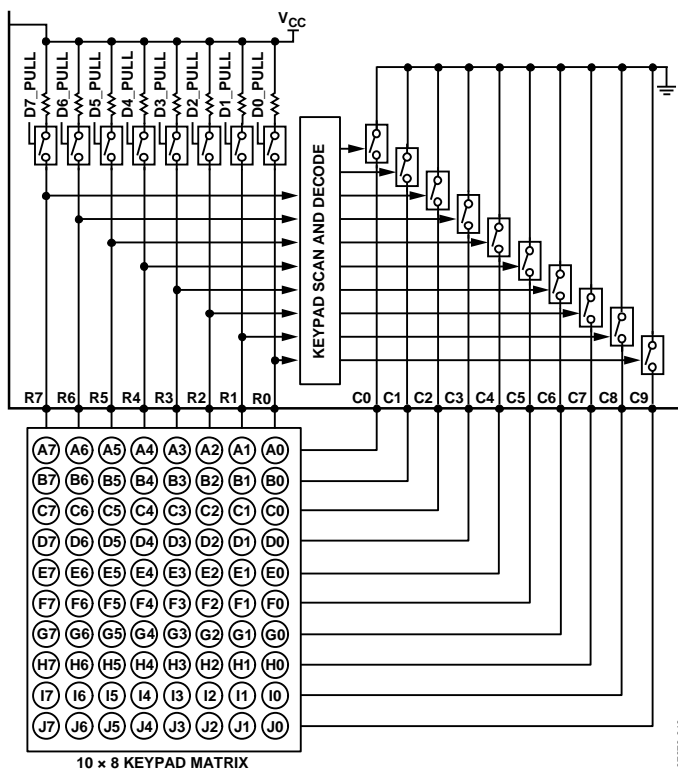

Figure 5. Keypad Decode Configuration

Key Event Tracking

The 10-key event registers are set to act as a FIFO, meaning that reading any of the 10-key event registers yields the key events in the order they were pressed and released.

Tracking of key events is done with the help of the key event counter (the KEC field in Register 0x03) and the FIFO/key event registers (Register 0x04 through Register 0x0D). The KEC count increases as keys are pressed and released; up to 10 events can be logged in the counter. The FIFO/key event registers, on the other hand, display the key events and their status (pressed or released) as they are read out of the FIFO. The FIFO registers are made of eight bits, with the MSB dedicated as the status bit (1 indicates a press and 0 indicates a release); the remaining seven bits are used to display binary representation of the keys that are pressed or released.

The first read of any of the FIFO registers displays the first event that happened and its status. Subsequent reads of the same register replace the register data with the next event that happens. If tracking of all the events is important, it is best to use a single register per event. After all the events in the FIFO are read, reading of any of the event registers yields a zero value.

Table 11 and Table 12 show the event sequences as they are logged in and read from the FIFO. The 10 FIFO registers are labeled A through J, and keys are labeled A0 through J7.

Table 11. Example of Event Sequence

Key Pressed/Released	Status	Key Event Counter
A0	Pressed	1
B1	Pressed	2
A0	Released	3
C2	Pressed	4
B1	Released	5
D3	Pressed	6
C2	Released	7
E4	Pressed	8
E4	Released	9
D3	Released	10

Table 12. Interpretation of FIFO Event Reading

Key Event Counter	Key Event Register Read	Key Event Register Content (Binary) ¹	Key Event Register Interpretation
10	N/A	N/A	N/A
9	D	1 0000001	Key A0 pressed
8	E	1 0001100	Key B1 pressed
7	C	0 0000001	Key A0 released
6	F	1 0010111	Key C2 pressed
5	G	0 0001100	Key B1 released
4	A	1 0100010	Key D3 pressed
3	B	0 0010111	Key C2 released
2	H	1 0101101	Key E4 pressed
1	J	0 0101101	Key E4 released
0	I	0 0100010	Key D3 released

¹ The first number indicates a key press or key release in Bit 7 of the key event register: 1 = key press; 0 = key release.

Key Event Overflow

The ADP5588 is equipped with an overflow feature to handle key events beyond the FIFO capacity. When all events are filled, any additional events set the OVR_FLOW_INT bit in Register 0x02; if the OVR_FLOW_IEN bit in Register 0x01 is set, the host processor is also interrupted when overflow occurs. When the FIFO is not full, new events are added as the last events.

The OVR_FLOW_M bit in Register 0x01 sets the mode of operation during overflows. Clearing the OVR_FLOW_M bit causes new incoming events to be discarded, and setting this bit rolls over and overwrites old data with new data starting at the first event.

Autoincrement

The ADP5588 features automatic increment during I²C read access. This allows the user to increment the address pointer without having to send a read command for subsequent addresses. This minimizes processor intervention and, therefore, saves processor bandwidth and current drain. Bit 7 of Register 0x01 must be set to initiate autoincrement (see Figure 16 for the full write and read sequence).

Key Event Interrupt

On a key event (KE) interrupt, the processor reads the interrupt register to determine the cause of the interrupt. If the KE_INT bit in Register 0x02 is the cause of the interrupt, the state machine sets the KE_INT bit and reads the key event count from the KEC[3:0] field in Register 0x03 to determine the number of events. It then reads the INT_STAT register (Register 0x02) to make sure that no new events have come in. After all the events are read, the KEC field is decremented to zero (KEC = 0) and the KE_INT bit can be cleared by writing a 1 to it. Both key presses and key releases are capable of generating key event interrupts. The KE_INT bit cannot be cleared, and the INT pin cannot be deasserted, until the FIFO is cleared of all events.

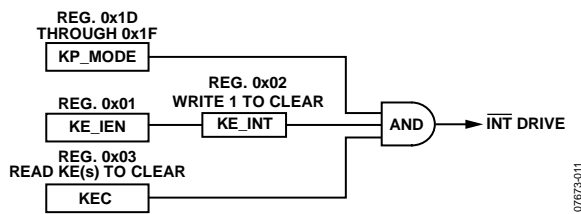

Figure 6. Key Event Interrupt Generation

Keypad Lock/Unlock Feature

The ADP5588 has a locking feature that allows the user to lock the keypad or GPIs (configured to be part of the event table). Once enabled, the keypad lock can prevent generation of key event interrupts and key events to be recorded in the key event table. This feature comprises the Unlock Key 1 and Unlock Key 2 registers (Register 0x0F and Register 0x10), the keypad lock interrupt mask, the keypad unlock timers (Register 0x0E), and the LCK1 and LCK2 bits, and the keylock enable bit (Register 0x03).

The unlock keys can be programmed with any value of the keys in the keypad matrix or any GPI values that are part of the key event table. When the keypad lock interrupt mask timer is enabled, the user must press two specific keys before a keylock interrupt is generated or keypad events are recorded. After the keypad is locked (set Bit 6, Register 0x03 to enable the lock), the first time that the user presses any key, a key event interrupt is generated. No additional interrupt is generated unless both unlock key sequences are correct; then a keylock interrupt is generated.

If the correct unlock keys are not pressed before the mask timer expires, the state machine starts over. The first key event interrupt is generated to allow the software to see that the user has pressed a key so that the host can turn on the LCD and

display the unlock message. The host then reads the lock status register to see if the keypad is unlocked. After the first key event interrupt, the state machine does not interrupt the processor again unless the correct sequence is keyed. The state machine resets if the correct sequences are not keyed before the keypad lock interrupt mask timer expires.

The state of the keypad lock interrupt mask bit (Register 0x01, Bit 2) in the configuration register determines whether the interrupt pin is asserted when the keylock interrupt status bit (Register 0x02, Bit 2) is set. Setting the keylock interrupt mask bit causes the INT pin to be asserted when the keylock interrupt status bit is set in Register 0x02; clearing that bit masks the interrupt, causing the interrupt pin not to respond to the keylock interrupt status bit. The mask interrupt timer should be set for the time that it takes for the LCD to dim or turn off so that, if a key is pressed, the backlight is set to bright mode again or reset to turn on the LCD.

When the unlock mask interrupt timer equals 0, only the correct unlock sequence can generate an interrupt. Disabling the unlock mask interrupt timer allows the processor to remain undisturbed for situations in which the user has the phone in a pocket or purse and the keys are constantly pressed. The flow chart in Figure 6 shows the interaction of the interrupt mask timer and interrupt generation.

GENERAL-PURPOSE INPUTS AND OUTPUTS

The ADP5588 supports up to 18 programmable GPIOs that can be configured to address a variety of uses. Figure 7 shows the makeup of a typical GPIO block where GPIOx represents any of the 18 I/O lines.

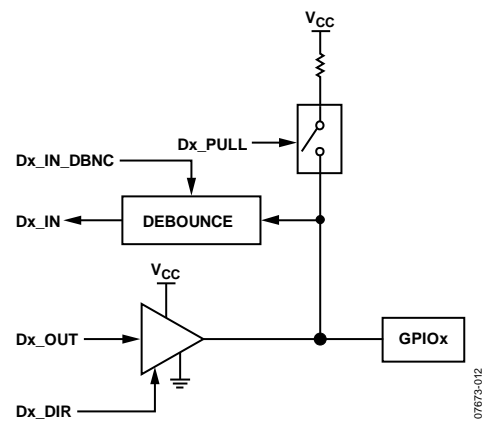

Figure 7. Typical GPIO Block

General Purpose Inputs (GPI)

The ADP5588 allows the user to configure all or some of its GPIOs into GPIs (general-purpose inputs). After the GPIOs are configured as GPIs, the user can opt to also turn on pull-up resistors and interrupt generation capability, thus reducing the amount of software monitoring and processor interaction and saving power.

The programmed level of the GPI interrupt determines the active level of the GPI pin. For example, if a GPI interrupt level

is programmed as high, a high on that pin is considered active and meets the interrupt requirement. If the interrupt is programmed as low, a low on that pin is considered active and meets the interrupt requirement.

GPI data and interrupt status are reflected in the GPIO interrupt and data status registers (Register 0x11 through Register 0x16). Caution must be taken during software implementation because an interrupt may be set immediately after register settings. To prevent this, correct logic levels must be present at the GPIs, and the GPIO interrupt level must be set before GPIO interrupt enable or GPI event FIFO enable registers are set. Figure 8 shows the interrupt generation scheme, where Dx represents any one of the 18 GPIOs.

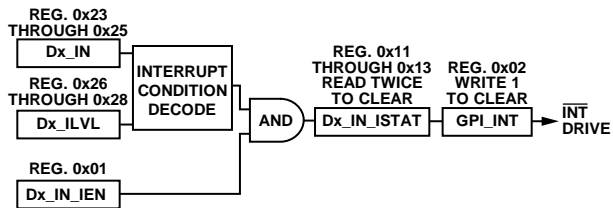

Figure 8. GPIO Interrupt Generation

GPI Events

A column or row configured as a GPI can be programmed to be part of the key event table and therefore also capable of generating a key event interrupt. A key event interrupt caused by a GPI follows the same process flow as a key event interrupt caused by a key press. GPIs configured as part of the key event table allow single key switches and other GPI interrupts to be monitored. As part of the event table, GPIs are represented by the decimal value 97 (0x61 or 1100001) through the decimal value 114 (0x72 or 1110010). See Table 13 and Table 14 for GPI event number assignments for rows and columns.

Table 13. GPI Event Number Assignments for Rows

R0	R1	R2	R3	R4	R5	R6	R7
97	98	99	100	101	102	103	104

Table 14. GPI Event Number Assignments for Columns

C0	C1	C2	C3	C4	C5	C6	C7	C8	C9
105	106	107	108	109	110	111	112	113	114

For a GPI that is set as active high, and is enabled in the key event table, the state machine adds an event to the event count and event table whenever that GPI goes high. If the GPI is set to active low, a transition from high to low is considered a press and is also added to the event count and event table. After the interrupt state is met, the state machine internally sets an interrupt for the opposite state programmed in the register to prevent polling for the released state, thereby saving current. After the released state is achieved, it is added to the event table. The press and release are still indicated by Bit 7 in the event register (Register 0x04 through Register 0x0D). The GPI events can also be used as unlocked sequences.

When the GPI_EM_REGx bit in Register 0x20 through Register 0x22 is set, GPI events are not tracked when the keypad is locked. The GPIEM_CFG bit (Register 0x01, Bit 6) must be cleared for the GPI events to be tracked in the event counter and event table when the keypad is locked.

50 Microsecond Interrupt Configuration

The ADP5588 gives the user the flexibility of deasserting the interrupt for 50 μs while there is a pending event. When the INT_CFG bit in Register 0x01 is set, any attempt to clear the interrupt bit while the interrupt pin is already asserted results in a 50 μs deassertion. When the INT_CFG bit is cleared, processor interrupt remains asserted if the host tries to clear the interrupt. This feature is particularly useful for software development and edge triggering applications.

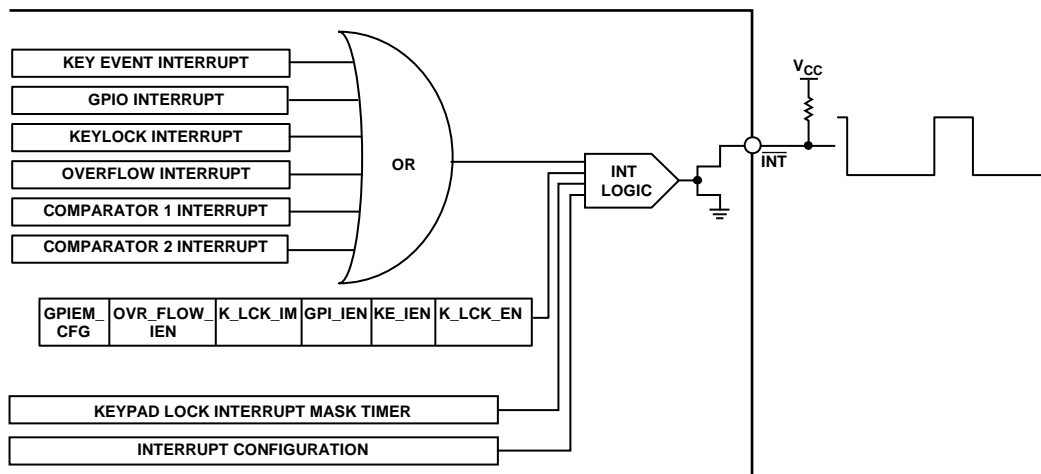

Figure 9. INT Pin Drive

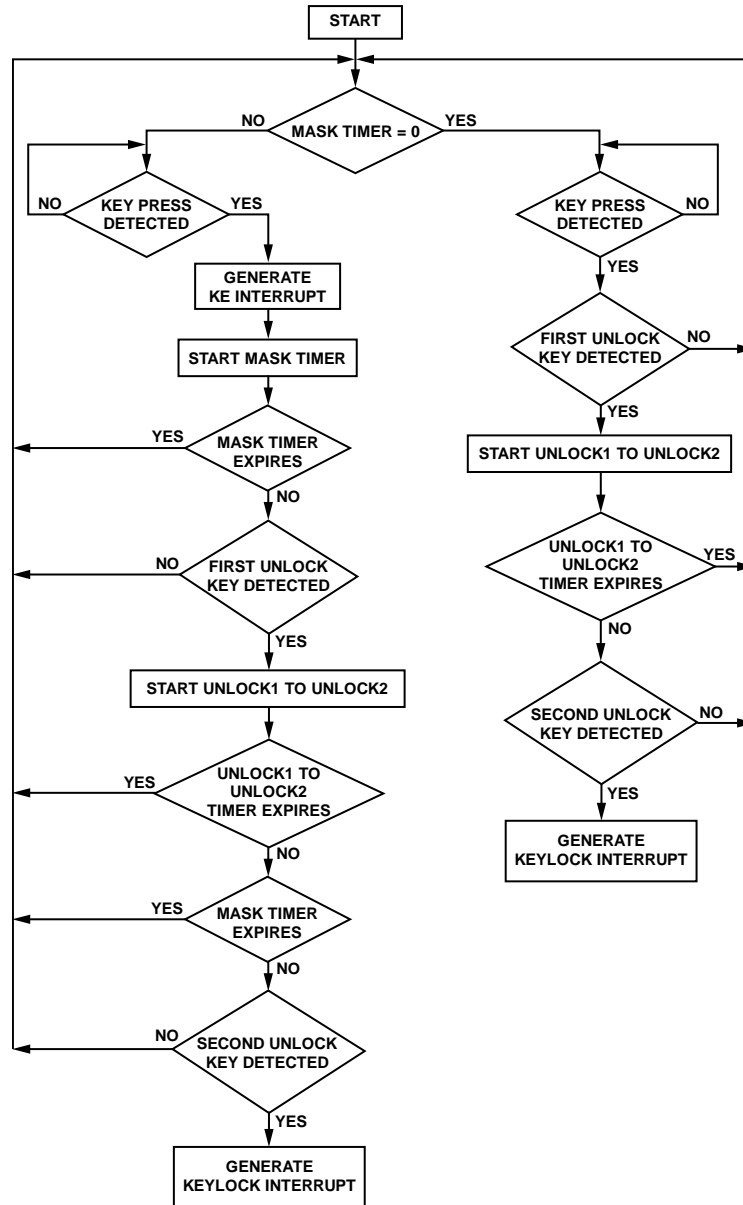

Figure 10. Keypad Lock Interrupt Mask Timer Flowchart

07673-015

Debouncing

The ADP5588 has a 50 μs debounce time for GPIOs configured as GPIs and rows in keypad scanning mode. The reset line always has a 50 μs debounce time.

General Purpose Outputs (GPOs)

The ADP5588 allows the user to configure all or some of its GPIOs as GPOs. These GPOs can be used as extra enables for the host processor or simply as trigger outputs. When configured as an output (GPO), a digital buffer drives the pin to 0 V for a 0 and to V_{CC} for a 1. To set any GPIO as a GPO, make sure that the corresponding bits in Register 0x1D through Register 0x1F are set for GPIO mode; then use Register 0x23 through Register 0x25 to set the corresponding bits for GPO mode.

Power-On Reset

For built-in power-up initialization for applications lacking a power-on reset signal, a reset pin, RST, allows the user to reset the registers to default values in the event of a brownout or other reset conditions.

Ambient Light Sensing

The ADP5588 has built in light sensor comparator inputs to detect ambient light conditions. An ADC samples the output of external photosensors connected to the comparator inputs, and the result is fed into programmable trip comparators. The ADC has an input range of 0 μA to 1000 μA (typical). The device can handle up to two photosensors (use Register 0x30 through Register 0x3A to configure the photosensor inputs).

Light Sensor Inputs

Each light sensor input has two built-in comparators (the L2 comparator and the L3 comparator) with two programmable trip points, L2 and L3. The trip points are used to select among three operation modes based on ambient lighting conditions: outdoor, office, and dark modes.

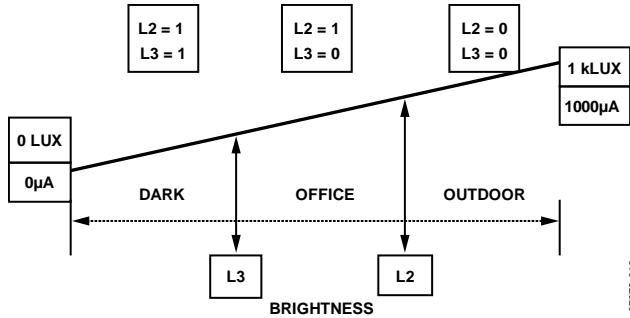

Figure 11. Light Sensor Comparator Modes and Trip Points

L2 Comparator

The L2 comparator is used to detect when the photosensor output drops below the programmable L2_TRIP point. When this event occurs, the L2_OUT status signal is set. L2_CMPR contains programmable hysteresis, meaning that the photo-sensor output must rise above L2_TRIP + L2_HYS before L2_OUT is cleared.

L2_CMPR is enabled via the L2_EN bit (Bit 0, Register 0x31 for Sensor 1 and Bit 0, Register 0x32 for Sensor 2). The L2_TRIP and L2_HYS values of L2_CMPR can be set between 0 μA and 1000 μA in steps of 4 μA.

L3 Comparator

The L3 comparator is used to detect when the photosensor output drops below the programmable L3_TRIP point. When this event occurs, the L3_OUT status signal is set. L3_CMPR contains programmable hysteresis, meaning that the photo-sensor output must rise above L3_TRIP + L3_HYS before L3_OUT is cleared. L3_CMPR is enabled via the L3_EN bit. The L3_TRIP and L3_HYS values of L3_CMPR can be set between 0 μA and 127.5 μA in steps of 0.5 μA.

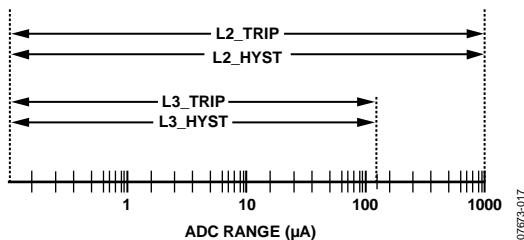

Figure 12. Comparator Ranges

The L2_CMPR and L3_CMPR comparators can be enabled independently of each other, and the ADC and comparator(s) run continuously when L2_EN and/or L3_EN is set.

Photosensor Operation

The comparator inputs remain idle until enabled, at which point they detect lighting conditions from the photosensor output. Depending on lighting conditions, and where the L2 and L3 trip points are set in the comparator level trip registers (Register 0x33 through Register 0x3A), the comparators set a value of 1 or 0 to L2_OUT and L3_OUT. The values of L2 and L3 determine what mode or setting adjustment is required for a particular lighting condition. Figure 11, Figure 12, and Table 15 summarize the mode settings and logical values of L2 and L3.

Table 15. L2_OUT and L3_OUT Comparator Mode Combination

L3	L2	Mode
0	0	Outdoor
0	1	Office
1	1	Dark

It is also possible to use the light sensor comparators in single-shot mode. A single-shot measurement is done when the FORCE_RD bit in Register 0x31 is set. After the single-shot measurement is completed, the internal state machine clears the FORCE_RD bit. It takes 80 ms for a complete conversion. To reduce the potential for flickering, the sensors can be programmed for a number of sequential readings. The filter settings in Register 0x31 and Register 0x32 determine the number of sequential readings needed by the user; these settings range from 80 ms to 10.24 sec.

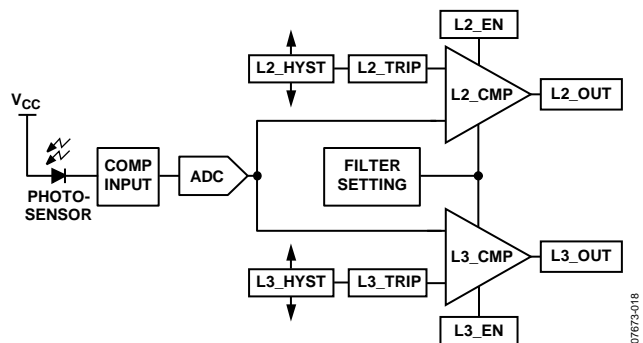

Figure 13. Light Sensor and Trip Points Block Diagram

Comparator Interrupt

The ADP5588 allows the user to trigger an interrupt based on the light sensor comparator inputs. Changes in lighting condition that cause the settings of L2 and L3 to jump from one mode to another (dark, office, outdoor) set the comparator interrupt bits

in Register 0x02. If the comparator interrupt enable bits are set, the interrupt pin is asserted every time the comparator interrupt bits are set. The comparator interrupt flag can be cleared only by writing a 1 to it.

Table 16. Device Configuration

Keypad			GPIO		Photosensor Inputs	
Matrix	Active Pins	Number of Keys	Available GPIO	Number of GPIOs	Photosensor Input Pin(s)	Number of Photosensor Inputs
10 × 8	C0 to C9, R0 to R7	80	0	0	None	0
8 × 8	C0 to C7, R0 to R7	64	0	0	C8, C9	2
			C8	1	C9	1
			C9	1	C8	1
8 × 7	C0 to C7, R0 to R6	56	R7	1	C8, C9	2
			C8, R7	2	C9	1
			R7, C8, C9	3	None	0
8 × 6	C0 to C7, R0 to R5	48	R6, R7	2	C8, C9	2
			R6, R7, C8	3	C9	1
			R6, R7, C8, C9	4	None	0
8 × 5	C0 to C7, R0 to R4	40	R5, R7	3	C8, C9	2
			R5 to R7, C8	4	C9	1
			R5 to R7, C8 to C9	5	None	0
7 × 7	C0 to C6, R0 to R6	49	R7, C7	2	C8, C9	2
			R7, C7 to C8	3	C9	1
			R7, C7 to C9	4	None	0
7 × 6	C0 to C6, R0 to R5	42	R6 to R7, C7	3	C8, C9	2
			R6 to R7, C7 to C8	4	C9	1
			R6 to R7, C7 to C9	5	None	0
7 × 5	C0 to C6, R0 to R4	35	R5 to R7, C7	4	C8, C9	2
			R5 to R7, C7 to C8	5	C9	1
			R5 to R7, C7 to C9	6	None	0
6 × 6	C0 to C5, R0 to R5	36	R6 to R7, C6 to C7	4	C8, C9	2
			R6 to R7, C6 to C8	5	C9	1
			R6 to R7, C6 to C9	6	None	0
6 × 5	C0 to C5, R0 to R4	30	R5 to R7, C6 to C7	5	C8, C9	2
			R5 to R7, C6 to C8	6	C9	1
			R5 to R7, C6 to C9	7	None	0
6 × 4	C0 to C5, R0 to R3	24	R4 to R7, C6 to C7	6	C8, C9	2
			R4 to R7, C6 to C8	7	C9	1
			R4 to R7, C6 to C9	8	None	0
...
0 × 0	None	0	R0 to R7, C0 to C9	18	None	0

I²C PROGRAMMING AND DIGITAL CONTROL

The ADP5588 provides full software programmability to facilitate its adoption in various product architectures. All register programming is done via the I²C bus at Address 0x69 (01101001) for a read and Address 0x68 (01101000) for a write.

All communication to the ADP5588 is done via its I²C-compatible serial interface. Figure 14 shows a typical write sequence for programming an internal register. The cycle begins with a start condition followed by the chip write address (0x68). The ADP5588 acknowledges the chip write address byte by pulling the data line low. The address of the register to which data is to be written is sent next. The ADP5588 acknowledges the register address byte by pulling the data line low. The data byte to be written is sent next. The ADP5588 acknowledges the data byte by pulling the data line low. A stop condition completes the sequence.

Figure 15 shows a typical read sequence for reading back an internal register. The cycle begins with a start condition followed by the chip write address (0x68). The ADP5588 acknowledges the chip write address byte by pulling the data line low. The address of the register from which data is to be read is sent next. The ADP5588 acknowledges the register address byte by pulling the data line low. The cycle continues with a repeat start followed by the chip read address (0x69). The ADP5588 acknowledges the chip read address byte by pulling the data line low. The ADP5588 places the contents of the previously addressed register on the bus for readback. There is no acknowledge following the readback data byte, and the cycle is completed with a stop condition.

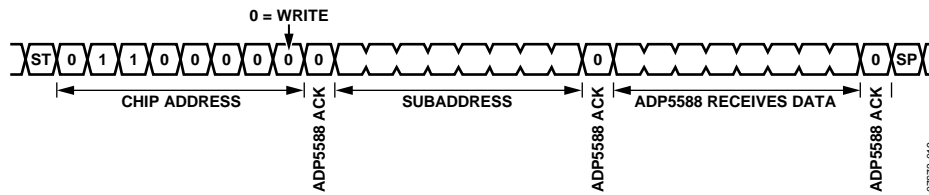

Figure 14. I²C Write Sequence

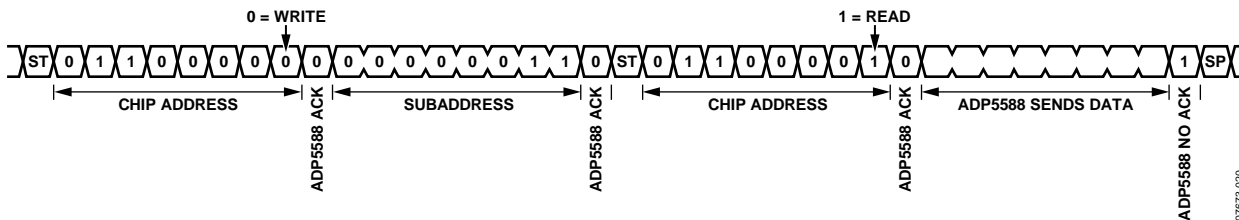

Figure 15. I²C Read and Write Sequences

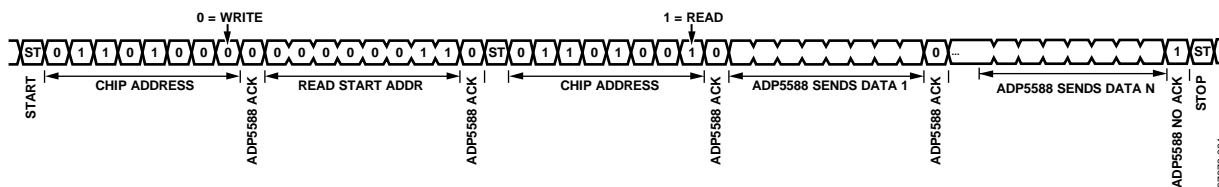

Figure 16. I²C Read Autoincrement

REGISTERS

The general behavior of registers is as follows:

- All registers are 0 on reset.
- All registers are read/write unless otherwise specified.
- Unused bits are read as 0.
- Interrupt bits are cleared by writing 1 to the flag; writing 0 or reading the flag has no effect, with the exception of the key press, key release, and GPIO interrupt status registers, which are cleared on a read.

Table 17.

Address	Register Name	Description
0x00	DEV_ID	Device ID
0x01	CFG	Configuration Register 1
0x02	INT_STAT	Interrupt status register
0x03	KEY_LCK_EC_STAT	Keylock and event counter register
0x04	KEY_EVENTA	Key Event Register A
0x05	KEY_EVENTB	Key Event Register B
0x06	KEY_EVENTC	Key Event Register C
0x07	KEY_EVENTD	Key Event Register D
0x08	KEY_EVENTE	Key Event Register E
0x09	KEY_EVENTF	Key Event Register F
0x0A	KEY_EVENTG	Key Event Register G
0x0B	KEY_EVENTH	Key Event Register H
0x0C	KEY_EVENTI	Key Event Register I
0x0D	KEY_EVENTJ	Key Event Register J
0x0E	KP_LCK_TMR	Keypad Unlock 1 to Keypad Unlock 2 timer
0x0F	UNLOCK1	Unlock Key 1
0x10	UNLOCK2	Unlock Key 2
0x11	GPIO_INT_STAT1	GPIO interrupt status
0x12	GPIO_INT_STAT2	GPIO interrupt status
0x13	GPIO_INT_STAT3	GPIO interrupt status
0x14	GPIO_DAT_STAT1	GPIO data status, read twice to clear
0x15	GPIO_DAT_STAT2	GPIO data status, read twice to clear
0x16	GPIO_DAT_STAT3	GPIO data status, read twice to clear
0x17	GPIO_DAT_OUT1	GPIO data out
0x18	GPIO_DAT_OUT2	GPIO data out
0x19	GPIO_DAT_OUT3	GPIO data out
0x1A	GPIO_INT_EN1	GPIO interrupt enable
0x1B	GPIO_INT_EN2	GPIO interrupt enable
0x1C	GPIO_INT_EN3	GPIO interrupt enable
0x1D	KP_GPIO1	Keypad or GPIO selection
0x1E	KP_GPIO2	Keypad or GPIO selection
0x1F	KP_GPIO3	Keypad or GPIO selection
0x20	GPI_EM_REG1	GPI Event Mode 1
0x21	GPI_EM_REG2	GPI Event Mode 2
0x22	GPI_EM_REG3	GPI Event Mode 3
0x23	GPIO_DIR1	GPIO data direction
0x24	GPIO_DIR2	GPIO data direction
0x25	GPIO_DIR3	GPIO data direction
0x26	GPIO_INT_LVL1	GPIO edge/level detect
0x27	GPIO_INT_LVL2	GPIO edge/level detect
0x28	GPIO_INT_LVL3	GPIO edge/level detect
0x29	DEBOUNCE_DIS1	Debounce disable
0x2A	DEBOUNCE_DIS2	Debounce disable
0x2B	DEBOUNCE_DIS3	Debounce disable
0x2C	GPIO_PULL1	GPIO pull disable
0x2D	GPIO_PULL2	GPIO pull disable

Address	Register Name	Description
0x2E	GPIO_PULL3	GPIO pull disable
0x2F	Not used	Not used
0x30	CMP_CFG_STAT	Comparator configuration and status register
0x31	CMP_CONFIG_SENS1	Sensor 1 comparator configuration register
0x32	CMP_CONFIG_SENS2	Sensor 2 comparator configuration register
0x33	CMP1_LVL2_TRIP	L2 light sensor reference level (output falling for Sensor 1)
0x34	CMP1_LVL2_HYS	L2 light sensor hysteresis (active when output rising) for Sensor 1
0x35	CMP1_LVL3_TRIP	L3 light sensor reference level (output falling for Sensor 1)
0x36	CMP1_LVL3_HYS	L3 light sensor hysteresis (active when output rising) for Sensor 1
0x37	CMP2_LVL2_TRIP	L2 light sensor reference level (output falling for Sensor 2)
0x38	CMP2_LVL2_HYS	L2 light sensor hysteresis (active when output rising) for Sensor 2
0x39	CMP2_LVL3_TRIP	L3 light sensor reference level (output falling for Sensor 2)
0x3A	CMP2_LVL3_HYS	L3 light sensor hysteresis (active when output rising) for Sensor 2
0x3B	CMP1_ADC_DAT_R1	Comparator 1 ADC Data Register 1
0x3C	CMP1_ADC_DAT_R2	Comparator 1 ADC Data Register 2
0x3D	CMP2_ADC_DAT_R1	Comparator 2 ADC Data Register 1
0x3E	CMP2_ADC_DAT_R2	Comparator 2 ADC Data Register 2

REGISTER DESCRIPTIONS

Table 18. DEV_ID—Register 0x00 (Device ID)

Register Name	Register Description	Bit 7	Bit 6	Bit 5	Bit 4	Bit 3	Bit 2	Bit 1	Bit 0
DEV_ID	Device ID[3:0], MFG ID[7:4]	MFID3	MFID2	MFID1	MFID0	DID3	DID2	DID1	DID0

Table 19. CFG—Register 0x01 (Configuration Register 1)

Field	Bit	Description
AUTO_INC	7	I ² C autoincrement. Burst read is supported; burst write is not supported. 1: I ² C autoincrement is on. 0: I ² C autoincrement is off.
GPIEM_CFG	6	GPI event mode configuration. 1: GPI events are not tracked when the keypad is locked. 0: GPI events are tracked when the keypad is locked.
OVR_FLOW_M	5	Overflow mode. 1: Overflow mode is on; register overflow data shifts in, starting at the last event and losing first event data. 0: Overflow mode is off; register overflow data is lost.
INT_CFG	4	Interrupt configuration. 1: Processor interrupt deasserts for 50 μ s and reasserts with pending key events. 0: Processor interrupt remains asserted when host tries to clear interrupt while there is a pending key event.
OVR_FLOW_IEN	3	Overflow interrupt enable. 1: Overflow interrupt is enabled. 0: Overflow interrupt is disabled.
K_LCK_IM	2	Keypad lock interrupt mask. 1: Keypad lock interrupt is enabled. 0: Keypad lock interrupt is disabled.
GPI_IEN	1	GPI interrupt enable. 1: GPI interrupt is enabled. 0: GPI interrupt is disabled.
KE_IEN	0	Key events interrupt enable. 1: Key events interrupt is enabled. 0: Key events interrupt is disabled.

Table 20. INT_STAT—Register 0x02 (Interrupt Status Register)

Field	Bit	Description
CMP2_INT	5	Comparator interrupt status. When set, write 1 to clear. 1: Comparator 2 interrupt is detected. 0: Comparator 2 interrupt is not detected.
CMP1_INT	4	Comparator interrupt status. When set, write 1 to clear. 1: Comparator 1 interrupt is detected. 0: Comparator 1 interrupt is not detected.
OVR_FLOW_INT ¹	3	Overflow interrupt status. When set, write 1 to clear. 1: Overflow interrupt is detected. 0: Overflow interrupt is not detected.
K_LCK_INT ²	2	Keylock interrupt status. When set, write 1 to clear. 1: Keylock interrupt is detected. 0: Keylock interrupt is not detected.
GPI_INT ^{1,3}	1	GPI interrupt status. When set, write 1 to clear. 1: GPI interrupt is detected. 0: GPI interrupt is not detected.
KE_INT ^{1,3}	0	Key events interrupt status. When set, write 1 to clear. 1: Key events interrupt is detected. 0: Key events interrupt is not detected.

¹ The KE_INT, GPI_INT, and OVR_FLOW_INT bits reflect the status of the interrupts when the interrupt types are enabled even if the processor interrupt is masked.

² The K_LCK_INT bit is the interrupt to the processor when the keypad lock sequence is triggered.

³ If there is a pending key event or GPI interrupt in their respective registers, KE_INT does not clear until the FIFO is empty, and the GPI_INT bit does not clear until the cause of the interrupt is resolved. The host must write a 1 to the INT bits to clear.

Table 21. KEY_LCK_EC_STAT—Register 0x03 (Keylock and Event Counter Register)

Field	Bit	Description
K_LCK_EN	[6]	0: Lock feature is disabled. 1: Lock feature is enabled.
LCK2, LCK1	[5:4]	Keypad lock status[1:0] (00 = unlocked; 11 = locked; read only bits).
KEC ¹	[3:0]	Key event count of key event register.

¹ The KEC bit indicates the key event count of key event registers that have values in the bit (KEC(0000) = 0 events, KEC(0001) = 1 event, KEC(1010) = 10 events. As the key events are read and cleared, the state machine automatically reduces the event count on KEC.

Table 22. KEY_EVENTx—Register 0x04 to Register 0x0D (Key Event Register A to Key Event Register J)¹

Register Name	Register Description	Bit 7	Bit 6	Bit 5	Bit 4	Bit 3	Bit 2	Bit 1	Bit 0
KEY_EVENTA (Register 0x04)	Key Event Register A status (KE[6:0] = Key number), KP[7] = 0: released, 1: pressed (cleared on read)	KA7	KA6	KA5	KA4	KA3	KA2	KA1	KA0
KEY_EVENTB (Register 0x05)	Key Event Register B status (KE[6:0] = Key number), KP[7] = 0: released, 1: pressed (cleared on read)	KB7	KB6	KB5	KB4	KB3	KB2	KB1	KB0
KEY_EVENTC (Register 0x06)	Key Event Register C status (KE[6:0] = Key number), KP[7] = 0: released, 1: pressed (cleared on read)	KC7	KC6	KC5	KC4	KC3	KC2	KC1	KC0
KEY_EVENTD (Register 0x07)	Key Event Register B status (KE[6:0] = Key number), KP[7] = 0: released, 1: pressed (cleared on read)	KD7	KD6	KD5	KD4	KD3	KD2	Kd1	KD0
KEY_EVENTE ² (Register 0x08)	Key Event Register B status (KE[6:0] = Key number), KP[7] = 0: released, 1: pressed (cleared on read)	KE7	KE6	KE5	KE4	KE3	KE2	KE1	KE0
KEY_EVENTF (Register 0x09)	Key Event Register B status (KE[6:0] = Key number), KP[7] = 0: released, 1: pressed (cleared on read)	KF7	KF6	KF5	KF4	KF3	KF2	KF1	KF0
KEY_EVENTG (Register 0x0A)	Key Event Register B status (KE[6:0] = Key number), KP[7] = 0: released, 1: pressed (cleared on read)	KG7	KG6	KG5	KG4	KG3	KG2	KG1	KG0
KEY_EVENTH (Register 0x0B)	Key Event Register B status (KE[6:0] = Key number), KP[7] = 0: released, 1: pressed (cleared on read)	KH7	KH6	KH5	KH4	KH3	KH2	KH1	KH0

Register Name	Register Description	Bit 7	Bit 6	Bit 5	Bit 4	Bit 3	Bit 2	Bit 1	Bit 0
KEY_EVENTI (Register 0x0C)	Key Event Register B status (KE[6:0] = Key number), KP[7] = 0: released, 1: pressed (cleared on read)	KI7	KI6	KI5	KI4	KI3	KI2	KI1	KI0
KEY_EVENTJ (Register 0x0D)	Key Event Register B status (KE[6:0] = Key number), KP[7] = 0: released, 1: pressed (cleared on read)	KJ7	KJ6	KJ5	KJ4	KJ3	KJ2	KJ1	KJ0

¹ Data in key events is provided as a FIFO, where data is sequentially provided on each read, regardless of an event register read. The user can read register Event A only for an event count or can read registers sequentially.

² KE[6:0] reflects the value 1 to 80 for key press events and the value 97 to 114 for GPI events. For KE[7:0], 0 = key released event, 1 = key pressed event. For GPIEM_CFG, 0 reflects a change in the GPI from GPI_INT_LVL = true to GPI_INT_LVL = false; 1 reflects a change in the GPI in which the GPI_INT_LVL condition becomes true.

Table 23. KP_LCK_TMR—Register 0x0E (Keypad Unlock 1 to Keypad Unlock 2 Timer)

Register Name	Register Description	Bit 7	Bit 6	Bit 5	Bit 4	Bit 3	Bit 2	Bit 1	Bit 0
KP_LCK_TMR (Register 0x0E)	Keypad UnLock 1 to Keypad UnLock 2 timer[2:0] (0: disabled, 1 sec to 7 sec) Keypad Lock Interrupt Mask Timer[7:3] (0: disabled, 0 sec to 31 sec) ^{1, 2}	KIMT7	KIMT6	KIMT5	KIMT4	KIMT3	KLLT2	KLLT1	KLLT0

¹ When the keypad lock interrupt mask timer is enabled, the user must press two specific keys before a keylock interrupt is generated or keypad events are recorded. After the keypad is locked, the first time that the user presses any key, a key event interrupt is generated. No additional interrupt is generated unless both unlock key sequences are correct; then a keylock interrupt is generated. When the interrupt mask timer is disabled (0), an interrupt is generated only when the correct full unlock sequence is completed.

² The Unlock 1 and Unlock 2 timer keys can be either a key sequence or GPIEM_CFG sequence. The unlock timer keys can be programmed with any value of the keys in the keypad matrix or any GPI values that are part of the key event table. The keylock enable bit (Bit 6, Register 0x03) must be set to lock the keypad.

Table 24. UNLOCK1—Register 0x0F (Unlock Key 1)

Register Name	Register Description	Bit 7	Bit 6	Bit 5	Bit 4	Bit 3	Bit 2	Bit 1	Bit 0
UNLOCK1 (Register 0x0F)	Unlock Key 1[6:0] (contains key number for Unlock Key 1; 0: disabled)	N/A	ULK6	ULK5	ULK4	ULK3	ULK2	ULK1	ULK0

Table 25. UNLOCK2—Register 0x10 (Unlock Key 2)

Register Name	Register Description	Bit 7	Bit 6	Bit 5	Bit 4	Bit 3	Bit 2	Bit 1	Bit 0
UNLOCK2 (Register 0x10)	Unlock Key 2[6:0] (contains key number for Unlock Key 2; 0: disabled)	N/A	ULK6	ULK5	ULK4	ULK3	ULK2	ULK1	ULK0

Table 26. GPIO_INT_STATx—Register 0x11 to Register 0x13 (GPIO Interrupt Status)

Register Name	Register Description	Bit 7	Bit 6	Bit 5	Bit 4	Bit 3	Bit 2	Bit 1	Bit 0
GPIO_INT_STAT1 (Register 0x11)	GPIO interrupt status (used to check GPIO interrupt status, cleared on read)	R7IS	R6IS	R5IS	R4IS	R3IS	R2IS	R1IS	R0IS
GPIO_INT_STAT2 (Register 0x12)	GPIO interrupt status (used to check GPIO interrupt status, cleared on read)	C7IS	C6IS	C5IS	C4IS	C3IS	C2IS	C1IS	C0IS
GPIO_INT_STAT3 (Register 0x13)	GPIO interrupt status (used to check GPIO interrupt status, cleared on read)	N/A	N/A	N/A	N/A	N/A	N/A	C9IS	C8IS

Table 27. GPIO_DAT_STATx—Register 0x14 to Register 0x16 (GPIO Data Status)

Register Name	Register Description	Bit 7	Bit 6	Bit 5	Bit 4	Bit 3	Bit 2	Bit 1	Bit 0
GPIO_DAT_STAT1 (Register 0x14)	GPIO data status (shows GPIO state when read for inputs)	R7DS	R6DS	R5DS	R4DS	R3DS	R2DS	R1DS	R0DS
GPIO_DAT_STAT2 (Register 0x15)	GPIO data status (shows GPIO state when read for inputs)	C7DS	C6DS	C5DS	C4DS	C3DS	C2DS	C1DS	C0DS
GPIO_DAT_STAT3 (Register 0x16)	GPIO data status (shows GPIO state when read for inputs)	N/A	N/A	N/A	N/A	N/A	N/A	C9DS	C8DS

Table 28. GPIO_DAT_OUTx—Register 0x17 to Register 0x19 (GPIO Data Out)

Register Name	Register Description	Bit 7	Bit 6	Bit 5	Bit 4	Bit 3	Bit 2	Bit 1	Bit 0
GPIO_DAT_OUT1 (Register 0x17)	GPIO data out (GPIO data to be written to GPIO out driver, inputs are not affected). This is needed so that the value can be written prior to being set as an output.	R7DO	R6DO	R5DO	R4DO	R3DO	R2DO	R1DO	R0DO
GPIO_DAT_OUT2 (Register 0x18)	GPIO data out (GPIO data to be written to GPIO out driver, inputs are not affected). This is needed so that the value can be written prior to being set as an output.	C7DO	C6DO	C5DO	C4DO	C3DO	C2DO	C1DO	C0DO
GPIO_DAT_OUT3 (Register 0x19)	GPIO data out (GPIO data to be written to GPIO out driver, inputs are not affected). This is needed so that the value can be written prior to being set as an output.	N/A	N/A	N/A	N/A	N/A	N/A	C9DO	C8DO

Table 29. GPIO_INT_ENx—Register 0x1A to Register 0x1C (GPIO Interrupt Enable)

Register Name	Register Description	Bit 7	Bit 6	Bit 5	Bit 4	Bit 3	Bit 2	Bit 1	Bit 0
GPIO_INT_EN1 (Register 0x1A)	GPIO interrupt enable (enables interrupts for GP inputs only)	R7IE	R6IE	R5IE	R4IE	R3IE	R2IE	R1IE	R0IE
GPIO_INT_EN2 (Register 0x1B)	GPIO interrupt enable (enables interrupts for GP inputs only)	C7IE	C6IE	C5IE	C4IE	C3IE	C2IE	C1IE	C0IE
GPIO_INT_EN3 (Register 0x1C)	GPIO interrupt enable (enables interrupts for GP inputs only)	N/A	N/A	N/A	N/A	N/A	N/A	C9IE	C8IE

Table 30. KP_GPIOx—Register 0x1D to Register 0x1F (Keypad or GPIO Selection)

Register Name	Register Description	Bit 7	Bit 6	Bit 5	Bit 4	Bit 3	Bit 2	Bit 1	Bit 0
KP_GPIO1 (Register 0x1D)	Keypad or GPIO selection 0: GPIO 1: KP matrix	R7	R6	R5	R4	R3	R2	R1	R0
KP_GPIO2 (Register 0x1E)	Keypad or GPIO selection 0: GPIO 1: KP matrix	C7	C6	C5	C4	C3	C2	C1	C0
KP_GPIO3 (Register 0x1F)	Keypad or GPIO selection 0: GPIO 1: KP matrix	N/A	N/A	N/A	N/A	N/A	N/A	C9	C8

Table 31. GPI_EM_REGx—Register 0x20 to Register 0x22 (GPI Event Mode 1 to GPI Event Mode 3)

Register Name	Register Description	Bit 7	Bit 6	Bit 5	Bit 4	Bit 3	Bit 2	Bit 1	Bit 0
GPI_EM_REG1 (Register 0x20)	GPI Event Mode Register 1 0: GPI not part of event FIFO 1: GPI part of event FIFO (R0 to R7)	R7_EM	R6_EM	R5_EM	R4_EM	R3_EM	R2_EM	R1_EM	R0_EM
GPI_EM_REG2 (Register 0x21)	GPI Event Mode Register 2 0: GPI not part of event FIFO 1: GPI part of event FIFO (C0 to C7)	C7_EM	C6_EM	C5_EM	C4_EM	C3_EM	C2_EM	C1_EM	C0_EM
GPI_EM_REG3 (Register 0x22)	GPI Event Mode Register 3 0: GPI not part of event FIFO 1: GPI part of event FIFO (C8 to C9)	NA	NA	NA	NA	NA	NA	C9_EM	C8_EM

Table 32. GPIO_DIRx—Register 0x23 to Register 0x25 (GPIO Data Direction)

Register Name	Register Description	Bit 7	Bit 6	Bit 5	Bit 4	Bit 3	Bit 2	Bit 1	Bit 0
GPIO_DIR1 (Register 0x23)	GPIO data direction 0: GPIO 1: Output	R7D	R6D	R5D	R4D	R3D	R2D	R1D	R0D
GPIO_DIR2 (Register 0x24)	GPIO data direction 0: GPIO 1: Output	C7D	C6D	C5D	C4D	C3D	C2D	C1D	C0D
GPIO_DIR3 (Register 0x25)	GPIO data direction 0: GPIO 1: Output	N/A	N/A	N/A	N/A	N/A	N/A	C9D	C8D

Table 33. GPIO_INT_LVLx—Register 0x26 to Register 0x28 (GPIO Edge/Level Detect)

Register Name	Register Description	Bit 7	Bit 6	Bit 5	Bit 4	Bit 3	Bit 2	Bit 1	Bit 0
GPIO_INT_LVL1 (Register 0x26)	GPIO INT level detect 0: Low 1: High	R7IL	R6IL	R5IL	R4IL	R3IL	R2IL	R1IL	R0IL
GPIO_INT_LVL2 (Register 0x27)	GPIO INT level detect 0: Low 1: High	C7IL	C6IL	C5IL	C4IL	C3IL	C2IL	C1IL	C0IL
GPIO_INT_LVL3 (Register 0x28)	GPIO INT level detect 0: Low 1: High	N/A	N/A	N/A	N/A	N/A	N/A	C9IL	C8IL

Table 34. DEBOUNCE_DISx—Register 0x29 to Register 0x2B (Debounce Disable)

Register Name	Register Description	Bit 7	Bit 6	Bit 5	Bit 4	Bit 3	Bit 2	Bit 1	Bit 0
DEBOUNCE_DIS1 (Register 0x29)	Debounce disable (inputs) 0: Enabled 1: Disabled	R7DD	R6DD	R5DD	R4DD	R3DD	R2DD	R1DD	R0DD
DEBOUNCE_DIS2 (Register 0x2A)	Debounce disable (inputs) 0: Enabled 1: Disabled	C7DD	C6DD	C5DD	C4DD	C3DD	C2DD	C1DD	C0DD
DEBOUNCE_DIS3 (Register 0x2B)	Debounce disable (inputs) 0: Enabled 1: Disabled	N/A	N/A	N/A	N/A	N/A	N/A	C9DD	C8DD

Table 35. GPIO_PULLx—Register 0x2C to Register 0x2E (GPIO Pull Disable)

Register Name	Register Description	Bit 7	Bit 6	Bit 5	Bit 4	Bit 3	Bit 2	Bit 1	Bit 0
GPIO_PULL1 (Register 0x2C)	GPIO pull disable (remove pull-ups from inputs) 0: Pull enabled 1: Pull disabled	R7PD	R6PD	R5PD	R4PD	R3PD	R2PD	R1PD	R0PD
GPIO_PULL2 (Register 0x2D)	GPIO pull disable (remove pull-ups from inputs) 0: Pull enabled 1: Pull disabled	C7PD	C6PD	C5PD	C4PD	C3PD	C2PD	C1PD	C0PD
GPIO_PULL3 (Register 0x2E)	GPIO pull disable (remove pull-ups from inputs) 0: Pull enabled 1: Pull disabled	N/A	N/A	N/A	N/A	N/A	N/A	C9PD	C8PD

Table 36. Register 0x2F

Field	Bit	Description
Not Used	N/A	Not used

COMPARATOR REGISTER DESCRIPTIONS

Table 37. CMP_CFG_STAT—Register 0x30 (Comparator Configuration and Status Register)

Field	Bit	Description
CMP2_L3_OUT	7	Sensor 2 Comparator L3 output. 0: Ambient light is greater than Level 3 (dark). 1: L3_CMP has detected a change in ambient light from Level 2 (office) to L3 (dark).
CMP2_L2_OUT	6	Sensor 2 Comparator L2 output. 0: Ambient light is greater than Level 2 (office). 1: L2_CMP has detected a change in ambient light from Level 1 (outdoor) to L2 (office).
CMP1_L3_OUT	5	Sensor 1 Comparator L3 output. 0: Ambient light is greater than Level 3 (dark). 1: L3_CMP has detected a change in ambient light from Level 2 (office) to L3 (dark).
CMP1_L2_OUT	4	Sensor 1 Comparator L2 output. 0: Ambient light is greater than Level 2 (office). 1: L2_CMP has detected a change in ambient light from Level 1 (outdoor) to L2 (office).
CMP2_IEN	3	Sensor 2 comparator interrupt. 0: Interrupt disabled. 1: Interrupt enabled.
CMP1_IEN	2	Sensor 1 comparator interrupt. 0: Interrupt disabled. 1: Interrupt enabled.
CMP2_EN	1	Sensor 2 comparator input. 0: Input disabled. 1: Input enabled.
CMP1_EN	0	Sensor 1 comparator input. 0: Input disabled. 1: Input enabled.

Table 38. CMP_CONFIG_SENS1—Register 0x31 (Sensor 1 Comparator Configuration Register)

Field	Bit	Description		
	[7:6]	Not used.		
FILT (2-0)	[5:3]	Programs the number of consecutive measurements required to transition the L2 and L3 levels.		
		FILT	Number Required	Approximate Time (sec)
		000	1	0.08
		001	2	0.16
		010	4	0.32
		011	8	0.64
		100	16	1.28
		101	32	2.56
		110	64	5.12
111	128	10.24		
FORCE_RD	2	1: Forces a read of the light sensor; reset by the internal state machine after conversion is complete and L2_OUT and L3_OUT are valid. ¹		
L3_EN	1	1: Enables the L3 comparator for Sensor 1 input. 0: Disables the L3 comparator for Sensor 1 input.		
L2_EN	0	1: Enables the L2 comparator for Sensor 1 input. 0: Disables the L2 comparator for Sensor 1 input. Note that the L3 comparator has priority over the L2 comparator.		

¹ When the software forces a conversion, the state machine clears the forced bit after the conversion is done and the proper registers have been updated.

Table 39. CMP_CONFIG_SENS2—Register 0x32 (Sensor 2 Comparator Configuration Register)

Field	Bit	Description		
	[7:6]	Not used.		
FILT (2-0)	[5:3]	Programs the number of consecutive measurements required to transition the L2 and L3 levels.		
		FILT	Number Required	Approximate Time (sec)
		000	1	0.08
		001	2	0.16
		010	4	0.32
		011	8	0.64
		100	16	1.28
		101	32	2.56
		110	64	5.12
	111	128	10.24	
FORCE_RD	2	1: Forces a read of the light sensor; reset by the internal state machine after conversion is complete and L2_OUT and L3_OUT are valid. ¹		
L3_EN	1	1: Enables the L3 comparator for Sensor 2 input. 0: Disables the L3 comparator for Sensor 2 input.		
L2_EN	0	1: Enables the L3 comparator for Sensor 2 input. 0: Disables the L3 comparator for Sensor 2 input. Note that the L3 comparator has priority over the L2 comparator.		

¹ When the software forces a conversion, the state machine clears the forced bit after the conversion is complete and the proper registers have been updated.

Table 40. CMP1_LVL2_TRIP—Register 0x33 (L2 Light Sensor Reference Level (Output Falling for Sensor 1))

Field	Bit	Description
L2_T7 to L2_T0	[7:0]	Sensor 1 comparator Level 2 (Office) reference. If the comparator input is below this trip point, the comparator trips and enters Level 2 (office) mode and L2_OUT is set. The programmable range is from 0 μ A to 1000 μ A (0 lux to 2550 lux) in steps of 4 μ A.

Table 41. CMP1_LVL2_HYS—Register 0x34 (L2 Light Sensor Hysteresis (Active When Output Rising) for Sensor 1)

Field	Bit	Description
L2_H7 to L2_H0	[7:0]	Sensor 1 comparator Level 2 (Office) hysteresis. If the comparator input is above L2_TRP + L2_HYS, the comparator trips and enters Level 1 (outdoor) mode and L2_OUT is cleared. The programmable range is from 0 μ A to 1000 μ A (0 lux to 2550 lux) in steps of 4 μ A.

Table 42. CMP1_LVL3_TRIP—Register 0x35 (L3 Light Sensor Reference Level (Output Falling for Sensor 1))

Field	Bit	Description
L3_T7 to L3_T0	[7:0]	Sensor 1 comparator Level 3 (Dark) reference. If the comparator input is below L3_TRP, the comparator trips and enters Level 3 (dark) mode and L3_OUT is set. The programmable range is from 0 μ A to 127.5 μ A (0 lux to 318.75 lux) in steps of 0.5 μ A.

Table 43. CMP1_LVL3_HYS—Register 0x36 (L3 Light Sensor Hysteresis (Active When Output Rising) for Sensor 1)

Field	Bit	Description
L3_H	[7:0]	Sensor 1 comparator Level 3 (Dark) hysteresis. If the comparator input is above L3_TRP + L3_HYS, the comparator trips and enters Level 2 (office) mode and L3_OUT is cleared. The programmable range is from 0 μ A to 127.5 μ A (0 lux to 318.75 lux) in steps of 0.5 μ A.

Table 44. CMP2_LVL2_TRIP—Register 0x37 (L2 Light Sensor Reference Level (Output Falling for Sensor 2))

Field	Bit	Description
L2_T7 to L2_T0	[7:0]	Sensor 2 comparator Level 2 (Office) reference. If the comparator input is below this trip point, the comparator trips and enters Level 2 (office) mode and L2_OUT is set. The programmable range is from 0 μ A to 1000 μ A (0 lux to 2550 lux) in steps of 4 μ A.

Table 45. CMP2_LVL2_HYS—Register 0x38 (L2 Light Sensor Hysteresis (Active When Output Rising) for Sensor 2)

Field	Bit	Description
L2_H7 to L2_H0	[7:0]	Sensor 2 comparator Level 2 (Office) hysteresis. If the comparator input is above L2_TRP + L2_HYS, the comparator trips and enters Level 1 (outdoor) mode and L2_OUT is cleared. The programmable range is from 0 μ A to 1000 μ A (0 lux to 2550 lux) in steps of 4 μ A.

Table 46. CMP2_LVL3_TRIP—Register 0x39 (L3 Light Sensor Reference Level (Output Falling for Sensor 2))

Field	Bit	Description
L3_T7 to L3_T0	[7:0]	Sensor 2 Comparator Level 3 (Dark) Reference. If the comparator input is below L3_TRP, the comparator trips and enters Level 3 (dark) mode and L3_OUT is set. The programmable range is from 0 μ A to 127.5 μ A (0 lux to 318.75 lux) in steps of 0.5 μ A.

Table 47. CMP2_LVL3_HYS—Register 0x3A (L3 Light Sensor Hysteresis (Active When Output Rising) for Sensor 2)

Field	Bit	Description
L3_H	[7:0]	Sensor 2 comparator Level 3 (Dark) hysteresis. If the comparator input is above L3_TRP + L3_HYS, the comparator trips and enters Level 2 (office) mode and L3_OUT is cleared. The programmable range is from 0 μ A to 127.5 μ A (0 lux to 318.75 lux) in steps of -.5 μ A.

Table 48. CMP1_ADC_DAT_R1—Register 0x3B (Comparator 1 ADC Data Register 1)

Register Name	Register Description	Bit 7	Bit 6	Bit 5	Bit 4	Bit 3	Bit 2	Bit 1	Bit 0
CMP1_ADC_DAT	Comparator ADC data register, Bits[7:0]	NA	NA	NA	ADC12	ADC11	ADC10	ADC9	ADC8

Table 49. CMP1_ADC_DAT_R2—Register 0x3C (Comparator 1 ADC Data Register 2)¹

Register Name	Register Description	Bit 7	Bit 6	Bit 5	Bit 4	Bit 3	Bit 2	Bit 1	Bit 0
CMP1_ADC_DAT	Comparator ADC data register, Bits[7:0]	ADC7	ADC6	ADC5	ADC4	ADC3	ADC2	ADC1	ADC0

¹ Read-only register; contains the most current 13-bit ADC data of the comparator for Sensor 1.

Table 50. CMP2_ADC_DAT_R1—Register 0x3D (Comparator 2 ADC Data Register 1)

Register Name	Register Description	Bit 7	Bit 6	Bit 5	Bit 4	Bit 3	Bit 2	Bit 1	Bit 0
CMP1_ADC_DAT	Comparator ADC Data Register [7:0]	N/A	N/A		ADC12	ADC11	ADC10	ADC9	ADC8

Table 51. CMP2_ADC_DAT_R2—Register 0x3E (Comparator 2 ADC Data Register 2)¹

Register Name	Register Description	Bit 7	Bit 6	Bit 5	Bit 4	Bit 3	Bit 2	Bit 1	Bit 0
CMP1_ADC_DAT	Comparator ADC data register, Bits[7:0]	ADC7	ADC6	ADC5	ADC	ADC3	ADC2	ADC1	ADC0

¹ Read-only register; contains the most current 13-bit ADC data of the comparator for Sensor 2.

APPLICATIONS INFORMATION

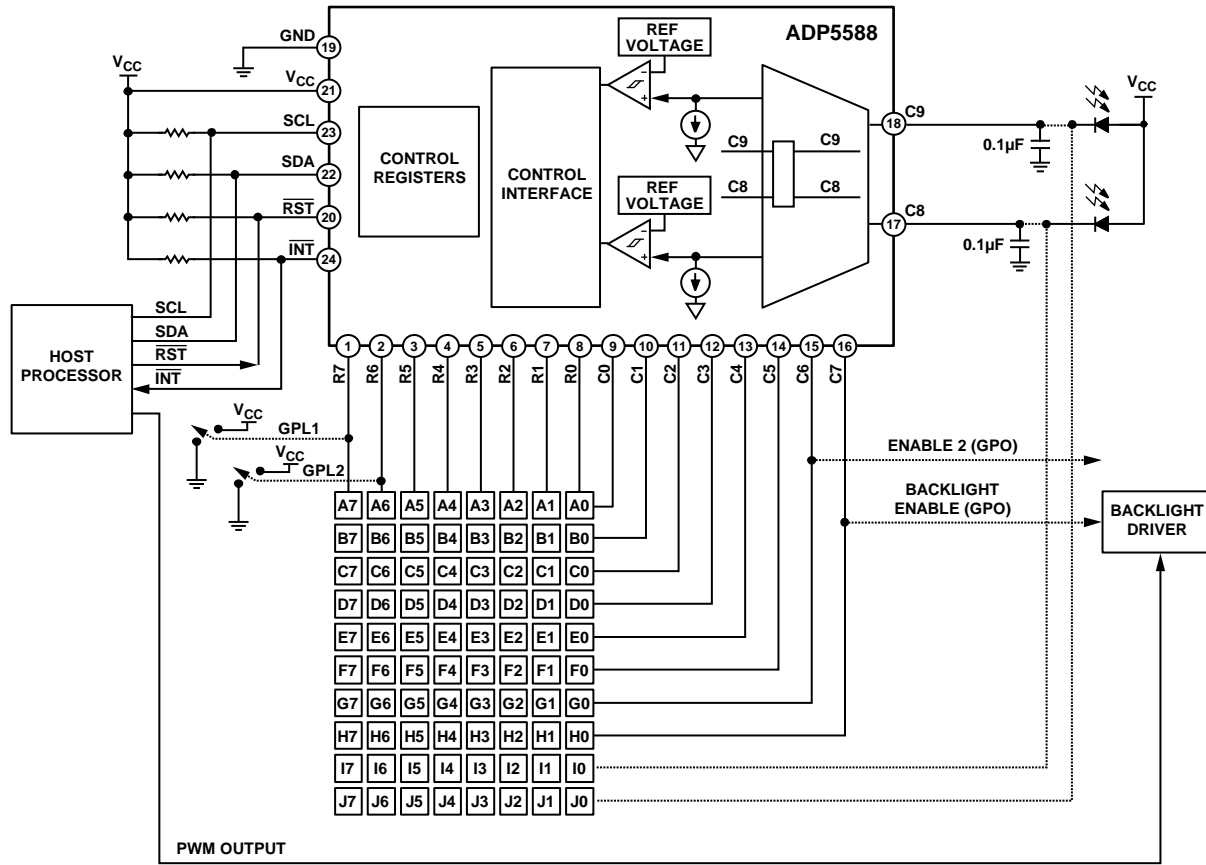

Figure 17. ADP5588 Detailed Application Block Diagram

APPLICATIONS OVERVIEW

The ADP5588 is designed to complement host processors in a variety of ways. Its versatility makes it the ideal solution for mobile platforms that require extended keypads and GPIO expanders. The programmable registers give the designer the flexibility to configure any or all its GPIOs in a variety of ways. Figure 17 shows a detailed application diagram.

KEYPAD CURRENT

Keypad current drain varies based on how many keys and how many rows and columns are pressed during multiple key presses. Table 52 shows typical current drain for a single press and for two key presses.

Table 52. Typical Current Drain

Key Presses	Conditions ¹	Typical	Unit
1	V _{CC} = 1.8 V to 3.0 V	55	µA
2	V _{CC} = 1.8 V to 3.0 V	100	µA

¹T_A = T_J = -40°C to +85°C.

BACKLIGHT CONTROL APPLICATION

Although the ADP5588 is not designed with a backlight driver, the built-in light sensor comparator inputs, with programmable registers and trip points, give the backlight designer all the necessary tools to control the backlight based on lighting conditions or environment. With a few I²C commands, the designer can program the device to monitor lighting conditions and trigger an interrupt based on preset trip points. Once programmed, the state machine uses these trip points and hysteresis values to alert the microprocessor of any change in lighting conditions. In addition to the L2_OUT and L3_OUT bits, four additional registers (Register 0x3B through Register 0x3E, two registers per light sensor) provide detailed accounts of the internal ADC due to light condition changes. The ADC has a full-scale current of 1000 µA and a dynamic range of 8000, which translates to 0.125 µA or 0.3125 lux per step. These two corresponding registers per sensor form a 13-bit register that can be read to provide detailed translation of the light sensor input at any instant.

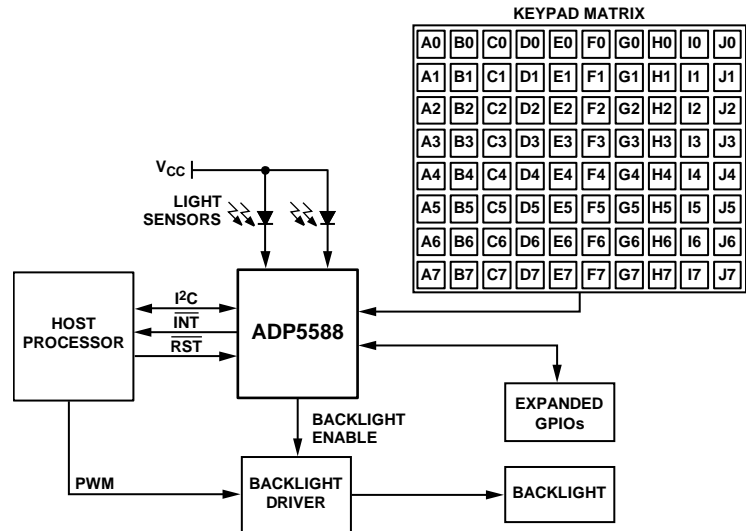
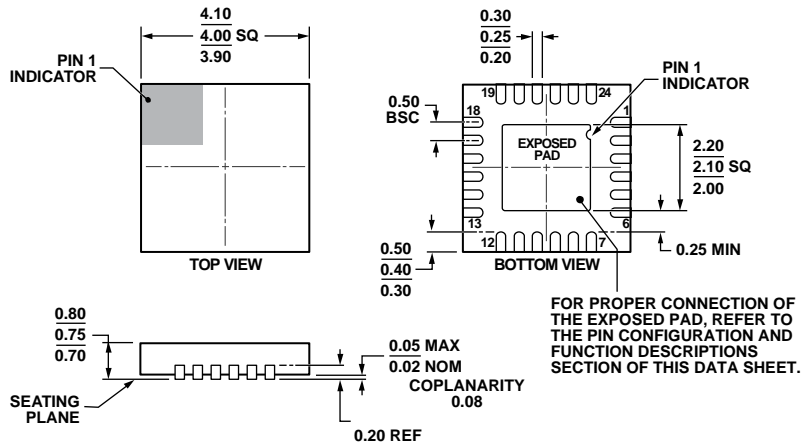

Figure 18. Integration Block Diagram

07679-023

OUTLINE DIMENSIONS



COMPLIANT TO JEDEC STANDARDS MO-220-WGGD-8.

Figure 19. 24-Lead Lead Frame Chip Scale Package [LFCSP_WQ]
 4 mm × 4 mm Body, Very Very Thin Quad
 (CP-24-10)
 Dimensions shown in millimeters

072899A

ORDERING GUIDE

Model ¹	Temperature Range	Package Description	Package Option
ADP5588ACPZ-R7	-40°C to +85°C	24-Lead Lead Frame Chip Scale Package [LFCSP_WQ]	CP-24-10
ADP5588-EVALZ		Evaluation Board	

¹ Z = RoHS Compliant Part.

NOTES

NOTES

Looking for pricing, stock, or lifecycle information?

Click below to explore more details on WIN SOURCE:

 [View ADP5588ACPZ-R7 on WIN SOURCE](#)

 [Analog Devices Inc. Information](#)

Optimize Your Supply Chain with WIN SOURCE Solutions

-  Global Sourcing Solution
-  Obsolete Management
-  Cost Control Management
-  Shortage Management
-  Alternative Solution
-  Excess Inventory Management