



**THE DATASHEET OF  
ADP3806JRU-REEL7**





# ADP3806—SPECIFICATIONS<sup>1</sup> (@ 0°C ≤ T<sub>A</sub> ≤ 100°C, VCC = 16 V, unless otherwise noted.)

Parameter	Conditions	Symbol	Min	Typ	Max	Unit
BATTERY SENSE INPUT ADP3806-12.6 V and 16.8 V ADP3806-12.525 V and 16.7 V	T <sub>A</sub> = 25°C, 13 V ≤ VCC ≤ 20 V 5°C ≤ T <sub>A</sub> ≤ 55°C 0°C ≤ T <sub>A</sub> ≤ 85°C	V <sub>BAT</sub> V <sub>BAT</sub> V <sub>BAT</sub>	-0.4 -0.6 -0.7		+0.4 +0.6 +0.7	% % %
Input Resistance	Part in Operation	R <sub>BAT</sub>	250	350		kΩ
Input Current	Part in Shutdown	I <sub>BAT(SD)</sub>		0.2	1.0	μA
BATTERY SENSE INPUT ADP3806 V <sub>BAT</sub> = 2.5 V	T <sub>A</sub> = 25°C, 13 V ≤ VCC ≤ 20 V 0°C ≤ T <sub>A</sub> ≤ 85°C	V <sub>BAT</sub> V <sub>BAT</sub>	-0.5 -0.7		+0.5 +0.7	% %
Input Current Operating	BATSEL = Open, Part in Operation			0.2	1.0	μA
Input Current Shutdown	BATSEL = 100 kΩ to GND, Part in Shutdown			0.2	1.0	μA
OSCILLATOR Maximum Frequency <sup>2</sup> Frequency Variation <sup>3</sup> CT Charge Current 0% Duty Cycle Threshold Maximum Duty Cycle Threshold SYNC Input High SYNC Input Low SYNC Input Current	CT = 180 pF  @ COMP Pin @ COMP Pin	f <sub>CT</sub> f <sub>CT</sub> I <sub>CT</sub>  SYNCH SYNCL I <sub>SYNC</sub>	1000 210 125	250 150 1.0 2.5	290 175	kHz kHz μA V V V μA
GATE DRIVE On Resistance Rise, Fall Time Overlap Protection Delay  SW Bias Current BST Cap Refresh Threshold	I <sub>L</sub> = 10 mA C <sub>L</sub> = 1 nF, DRVL and DRVH DRVL Falling to DRVH Rising, DRVH Falling to DRVL Rising Part in Shutdown, V <sub>SW</sub> = 12.6 V V <sub>BST</sub> - V <sub>SW</sub>	R <sub>ON</sub> t <sub>r</sub> , t <sub>f</sub> t <sub>OP</sub>		6 35 50	10	Ω ns ns
CURRENT SENSE AMPLIFIER Input Common-Mode Range Input Differential Mode Range Input Offset Voltage <sup>5</sup> Gain <sup>5</sup> Input Bias Current Input Offset Current Input Bias Current DRVL Shutdown Threshold	V <sub>CS+</sub> and V <sub>CS-</sub> V <sub>CS</sub> <sup>4</sup> 0 V ≤ V <sub>CS(CM)</sub> ≤ VCC	V <sub>CS(CM)</sub> V <sub>CS(DM)</sub> V <sub>CS(VOS)</sub>	0.0 0.0		VCC + 0.3 160	V mV mV
	0 V ≤ V <sub>CS(CM)</sub> ≤ VCC, Part in Operation	V <sub>CS(IB)</sub>		1.0 25		mV/V
	0 V ≤ V <sub>CS(CM)</sub> ≤ VCC	V <sub>CS(IB)</sub>		50	100	μA
	Part in Shutdown	V <sub>CS(IOS)</sub>		1.0	2.0	μA
	Measured between V <sub>CS+</sub> and V <sub>CS-</sub>	V <sub>CS(SD)</sub>		0.2	1.0	μA
				48		mV
SYSTEM CURRENT SENSE <sup>6</sup> Input Common-Mode Range Input Differential Range Input Offset Voltage Input Bias Current, SYS+ Input Bias Current, SYS- Voltage Gain Output Range Limit Output Threshold Limit Output Voltage	SYS+ and SYS-, I <sub>L</sub> = 0 mA, V <sub>ISYS</sub> = 3 V (V <sub>SYS+</sub> ) - (V <sub>SYS-</sub> )  V <sub>SYS(DM)</sub> = 0 V, V <sub>SYS(CM)</sub> = 16 V V <sub>SYS(DM)</sub> = 0 V, V <sub>SYS(CM)</sub> = 16 V 10 V ≤ V <sub>SYS(CM)</sub> ≤ VCC + 0.3 V, I <sub>L</sub> = 100 μA I <sub>L</sub> = 1 mA <sup>7</sup> , V <sub>SYS(CM)</sub> > 6 V V <sub>LIMIT</sub> ≤ 0.2 V, 50 kΩ Pull-up to 5 V V <sub>ISYS</sub> > 2.65 V, I <sub>SINK</sub> = 700 μA	V <sub>SYS(CM)</sub> V <sub>SYS(DM)</sub>  I <sub>B(SYS+)</sub> I <sub>B(SYS-)</sub>  V <sub>ISYS</sub> V <sub>TH(LIMIT)</sub> V <sub>O(LIMIT)</sub>	4.0 0	0.5 200 70 48.5 0 2.3	VCC + 0.3 100 300 125 51.5 5.0 2.7	V mV mV μA μA V/V V V V
ISET INPUT Charge Current Programming Function Programming Function Accuracy	0.0 V < V <sub>ISET</sub> ≤ 4.0 V V <sub>ISET</sub> = 4.0 V, 1 V ≤ V <sub>CS(CM)</sub> ≤ 16 V V <sub>ISET</sub> = 0.50 V, 1 V ≤ V <sub>CS(CM)</sub> ≤ 10 V 5°C ≤ T <sub>A</sub> ≤ 55°C, V <sub>ISET</sub> = 206 mV, V <sub>CS(CM)</sub> = 5 V and 10 V	V <sub>ISET/VCS</sub>		25		V/V
			-5 -30 -46.7	±1.0 ±10	+5 +30 +33	% % %
ISET Bias Current	0.0 V ≤ V <sub>ISET</sub> ≤ 4.0 V	I <sub>B</sub>		0.2	1.0	μA

Parameter	Conditions	Symbol	Min	Typ	Max	Unit
BATSEL INPUT $V_{BAT} = 12.6\text{ V}$ $V_{BAT} = 16.8\text{ V}$ BATSEL Input Current			2.0		0.8	V V $\mu\text{A}$
BOOST REGULATOR OUTPUT Output Voltage Output Current <sup>8</sup>	$C_L = 0.1\ \mu\text{F}$	$V_{BSTREG}$ $I_{BSTREG}$	6.8 3.0	7.0 5.0	7.2	V mA
ANALOG REGULATOR OUTPUT Output Voltage Output Current <sup>8</sup>	$C_L = 10\ \text{nF}$	$V_{REG}$ $I_{REG}$	5.8 3.0	6.0 5.0	6.2	V mA
PRECISION REFERENCE OUTPUT Output Voltage Output Current <sup>8</sup>		$V_{REF}$ $I_{REF}$	2.47 0.5	2.5 1.1	2.53	V mA
SHUTDOWN ( $\overline{SD}$ ) ON OFF $\overline{SD}$ Input Current		$\overline{SD}_H$ $\overline{SD}_L$	2.0		0.8	V V $\mu\text{A}$
POWER SUPPLY ON Supply Current OFF Supply Current UVLO Threshold Voltage UVLO Hysteresis	No External Loads, $UVLO \leq VCC \leq 20\text{ V}$ No External Loads, $VCC \leq 20\text{ V}$ Turn On Turn Off	$I_{SYON}$ $I_{SYOFF}$ $V_{UVLO}$		6.0 1.0 6.0 0.3	8.0 5.0 6.25 0.5	mA $\mu\text{A}$ V V
LC OUTPUT Output Voltage Low Output Voltage High	High Current Mode <sup>9</sup> , $I_{SINK} = 100\ \mu\text{A}$ Low Current Mode <sup>10</sup>			0.1 External	0.4	V V
OUTPUT REVERSE LEAKAGE PROTECTION Leakage Current	$VCC = \text{Floating}, V_{BAT} = 12.6\text{ V}$	$I_{DISCH}$		1	5	$\mu\text{A}$
OVERCURRENT COMPARATOR Overcurrent Threshold Response Time	$V_{CS} > 180\text{ mV to COMP} < 1\text{ V}$	$V_{CS(OC)}$ $t_{OC}$		180 2		mV $\mu\text{s}$
OVERVOLTAGE COMPARATOR Overvoltage Threshold Response Time	$V_{BAT} > 120\% \text{ to COMP} < 1\text{ V}$	$V_{BAT(OV)}$ $t_{OV}$		120 2		% $\mu\text{s}$

## NOTES

<sup>1</sup>All limits at temperature extremes are guaranteed via correlation using standard Statistical Quality Control (SQC) methods.

<sup>2</sup>Guaranteed by design, not tested in production.

<sup>3</sup>If SYNC function is used, then  $f_{SYNC}$  must be greater than  $f_{CT}$  but less than 120% of  $f_{CT}$ .

<sup>4</sup> $V_{CS} = (V_{CS+}) - (V_{CS-})$ .

<sup>5</sup>Accuracy guaranteed by ISET input, programming function accuracy specification.

<sup>6</sup>System current sense is active during shutdown.

<sup>7</sup>Load current is supplied through SYS+ pin.

<sup>8</sup>Guaranteed output current from 0 to min specified value to maintain regulation.

<sup>9</sup> $V_{BAT} < 93\%$  of final or  $V_{CS} > 25\text{ mV}$ .

<sup>10</sup> $V_{BAT} \geq 93\%$  of final and  $V_{CS} \leq 25\text{ mV}$ .

Specifications subject to change without notice.

# ADP3806

## ABSOLUTE MAXIMUM RATINGS\*

Input Voltage (VCC)	-0.3 V to +25 V
BAT, CS+, CS-	-0.3 V to VCC + 0.3 V
SYS+, SYS-	-25 V to +25 V
BST	-0.3 V to +30 V
BST to SW	-0.3 V to +8 V
SW to PGND	-4 V to +25 V
DRV1 to PGND	-0.3 V to +8 V
ISET, BATSEL, $\overline{SD}$ , SYNC, CT, LIMIT, ISYS, LC	-0.3 V to +10 V
COMP	-0.3 V to +3 V
GND to PGND	-0.3 V to +0.3 V

Operating Ambient Temperature Range	0°C to 100°C
$\theta_{JA}$	115°C/W
Operating Junction Temperature Range	0°C to 125°C
Storage Temperature Range	-65°C to +150°C
Lead Temperature Range (Soldering 10 sec)	300°C

\*Stresses above those listed under Absolute Maximum Ratings may cause permanent damage to the device. This is a stress rating only; functional operation of the device at these or any other conditions above those listed in the operational sections of this specification is not implied. Exposure to absolute maximum rating conditions for extended periods may affect device reliability. Absolute maximum ratings apply individually only, not in combination. Unless otherwise specified all other voltages are referenced to GND.

## ORDERING GUIDE

Model	Battery Voltage	Package Description	Package Option	Quantity per Reel
ADP3806JRU-REEL	Adjustable	TSSOP-24	RU-24	2500
ADP3806JRU-REEL7	Adjustable	TSSOP-24	RU-24	1000
ADP3806JRU-12.5-RL	12.525 V/16.7 V	TSSOP-24	RU-24	2500
ADP3806JRUZ-12.5RL*	12.525 V/16.7 V	TSSOP-24	RU-24	2500
ADP3806JRU-12.5-R7	12.525 V/16.7 V	TSSOP-24	RU-24	1000
ADP3806JRU-12.6-RL	12.600 V/16.8 V	TSSOP-24	RU-24	2500
ADP3806JRU-12.6-R7	12.600 V/16.8 V	TSSOP-24	RU-24	1000

\*Z = Pb-free part.

## CAUTION

ESD (electrostatic discharge) sensitive device. Electrostatic charges as high as 4000 V readily accumulate on the human body and test equipment and can discharge without detection. Although the ADP3806 features proprietary ESD protection circuitry, permanent damage may occur on devices subjected to high energy electrostatic discharges. Therefore, proper ESD precautions are recommended to avoid performance degradation or loss of functionality.



### PIN CONFIGURATION

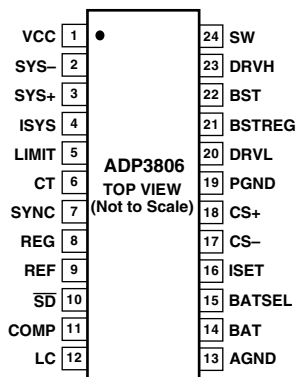

### PIN FUNCTION DESCRIPTION

Pin No.	Mnemonic	Function
1	VCC	Supply Voltage.
2	SYS-	Negative System Current Sense Input.
3	SYS+	Positive System Current Sense Input.
4	ISYS	System Current Sense Output.
5	LIMIT	System Current Sense Limit Output.
6	CT	Oscillator Timing Capacitor.
7	SYNC	Oscillator Synchronization Pin.
8	REG	6.0 V Analog Regulator Output.

### PIN FUNCTION DESCRIPTION(continued)

Pin No.	Mnemonic	Function
9	REF	2.5 V Precision Reference Output.
10	$\overline{SD}$	Shutdown Control Input.
11	COMP	External Compensation Node.
12	LC	Low Current Output.
13	AGND	Analog Ground.
14	BAT	Battery Sense Input. 2.5 V for ADP3806. 12.525 V/16.7 V for ADP3806-12.5. 12.6 V/16.8 V for ADP3806-12.6.
15	BATSEL	Battery Voltage Sense Input. High = 3 Cells, Low = 4 Cells.
16	ISET	Charge Current Program Input.
17	CS-	Negative Current Sense Input.
18	CS+	Positive Current Sense Input.
19	PGND	Power Ground.
20	DRVL	Low Drive Output Switches between REG and PGND.
21	BSTREG	7.0 V Regulator Output for Boost.
22	BST	Floating Bootstrap Supply for DRVH.
23	DRVH	High Drive Output Switches between SW and BST.
24	SW	Buck Switching Node Reference for DRVH.

# ADP3806—Typical Performance Characteristics

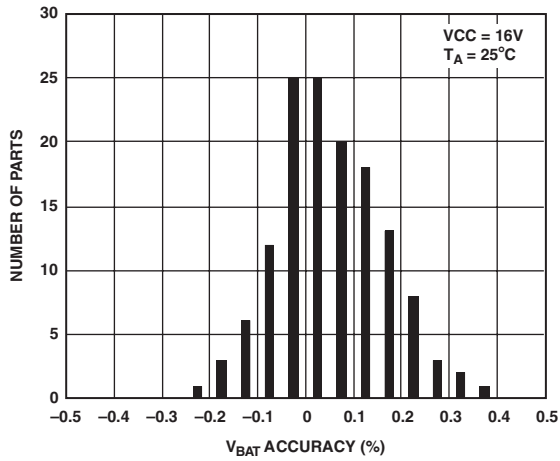

TPC 1.  $V_{BAT}$  Accuracy Distribution

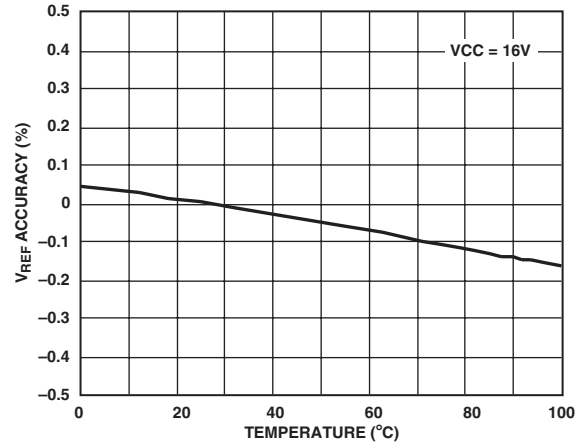

TPC 4.  $V_{REF}$  Accuracy vs. Temperature

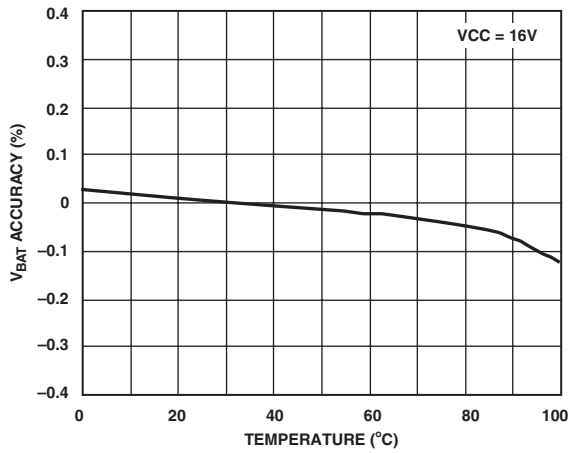

TPC 2.  $V_{BAT}$  Accuracy vs. Temperature

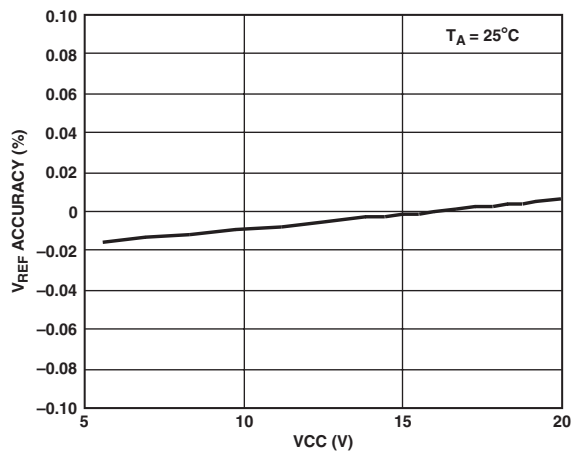

TPC 5.  $V_{REF}$  Accuracy vs. VCC

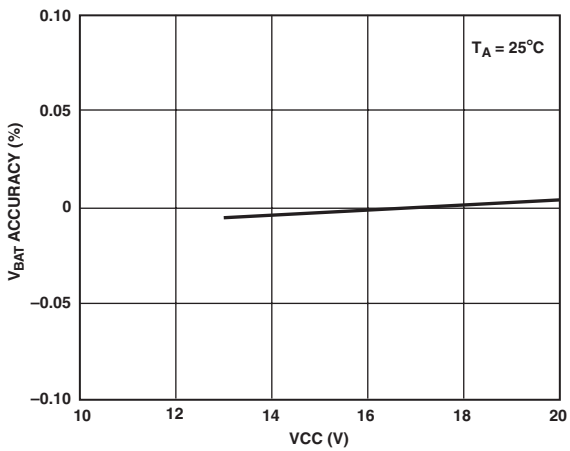

TPC 3.  $V_{BAT}$  Accuracy vs. VCC

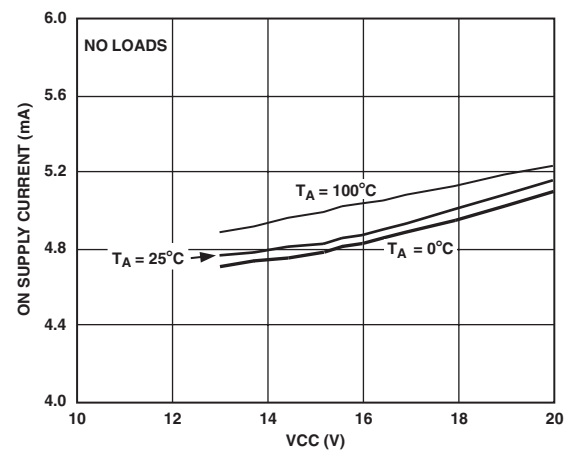

TPC 6. ON Supply Current vs. VCC

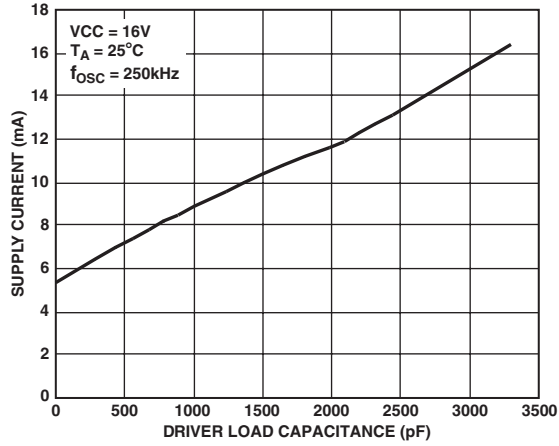

TPC 7. Supply Current vs. Driver Load Capacitance

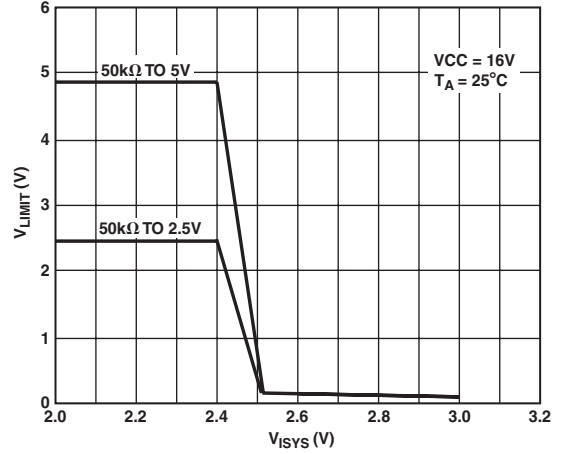

TPC 10.  $V_{LIMIT}$  vs.  $V_{ISYS}$

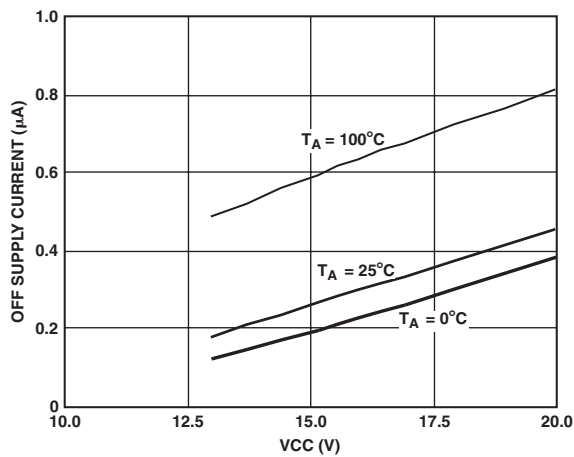

TPC 8. Off Supply Current vs. VCC

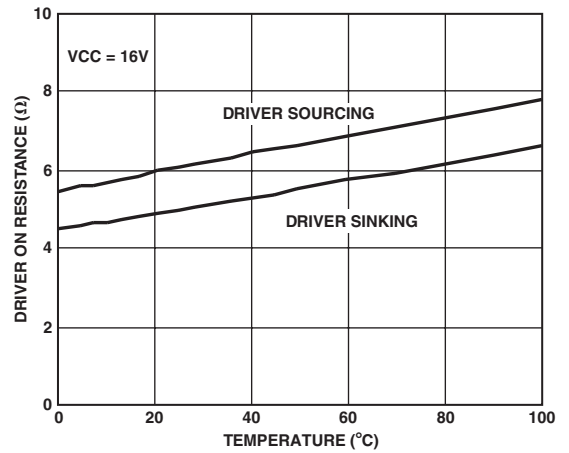

TPC 11. Driver On Resistance vs. Temperature

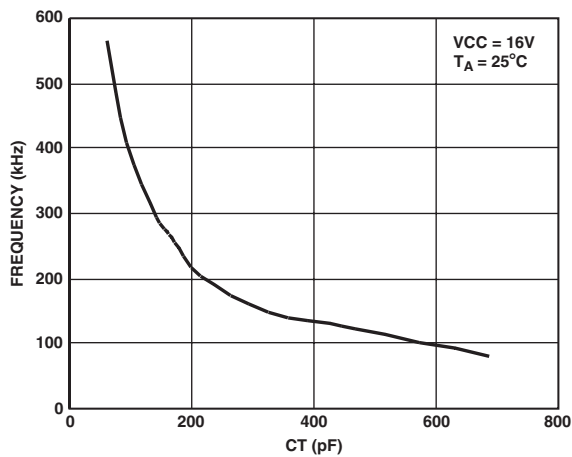

TPC 9. Oscillator Frequency vs. CT

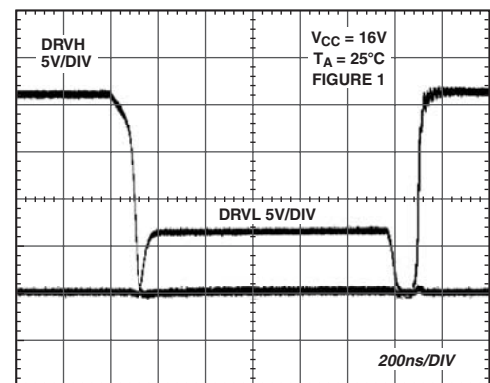

TPC 12. Driver Waveforms

# ADP3806

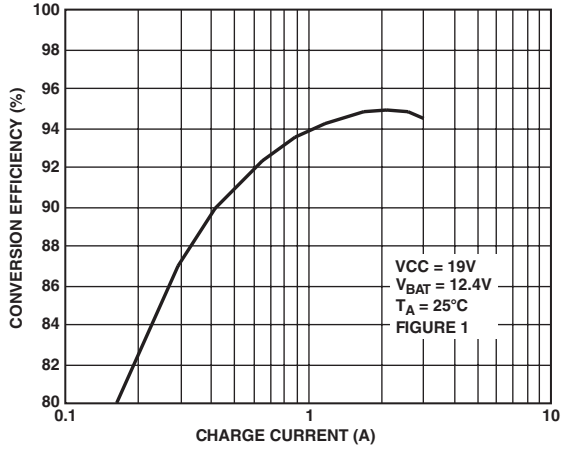

TPC 13. Conversion Efficiency vs. Charge Current

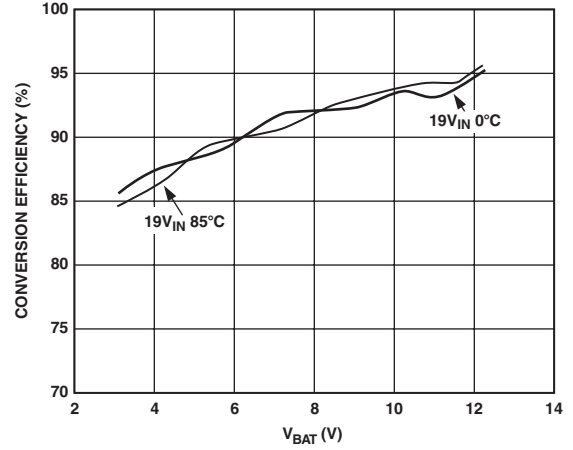

TPC 15. Conversion Efficiency vs. Battery Voltage at Given Temperatures

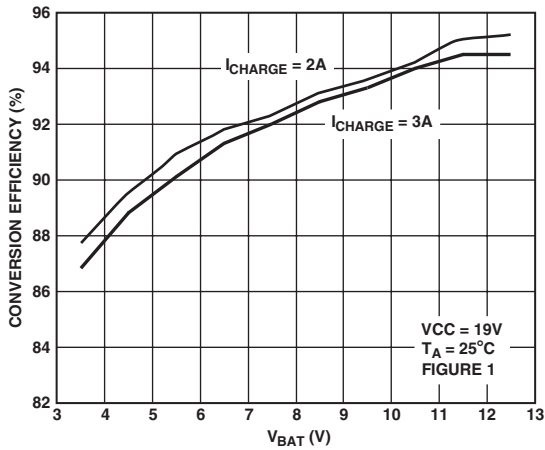

TPC 14. Conversion Efficiency vs. Battery Voltage

## THEORY OF OPERATION

The ADP3806 combines a bootstrapped synchronous switching driver with programmable current control and accurate final battery voltage control in a constant-current, constant-voltage (CCCV) Li-Ion battery charger. High accuracy voltage control is needed to safely charge Li-Ion batteries, which are typically specified at  $4.2\text{ V} \pm 1\%$  per cell. For a typical notebook computer battery pack, three or four cells are in series giving a total voltage of 12.6 V or 16.8 V. The ADP3806 is available in three versions, a selectable 12.525 V/16.7 V output, a selectable 12.6 V/16.8 V output, and an adjustable output. The adjustable output can be programmed for a wide range of battery voltages using two external precision resistors.

Another requirement for safely charging Li-Ion batteries is accurate control of the charge current. The actual charge current depends on the number of cells in parallel within the battery pack. Typically, this is in the range of 2 A to 3 A. The ADP3806 provides flexibility in programming the charge current over a wide range. An external resistor is used to sense the charge current and this voltage is compared to a dc input voltage. This programmability allows the current to be changed during charging. For example, the charge current can be reduced for trickle charging.

The synchronous driver provides high efficiency when charging at high currents. Efficiency is important mainly to reduce the amount of heat generated in the charger but also to stay within the power limits of the ac adapter. With the addition of a bootstrapped high side driver, the ADP3806 drives two external power NMOS transistors for a simple, lower cost power stage.

The ADP3806 also provides an uncommitted current sense amplifier. This amplifier provides an analog output pin for monitoring the current through an external sense resistor. The amplifier can be used anywhere in the system that high side current sensing is needed.

## Charge Current Control

AMP1 in Figure 1 has a differential input to amplify the voltage drop across an external sense resistor RCS. The input common-mode range is from ground to VCC, allowing current control in short circuit and low dropout conditions. The gain of AMP1 is internally set to 25 V/V for low voltage drop across the sense resistor. During CC mode,  $g_{m1}$  forces the voltage at the output of AMP1 to be equal to the external voltage at the ISET pin. By choosing  $R_{CS}$  and  $V_{ISET}$  appropriately, a wide range of charge currents can be programmed.

$$I_{CHARGE} = \frac{V_{REF}}{25 \times R_{CS}} \quad (1)$$

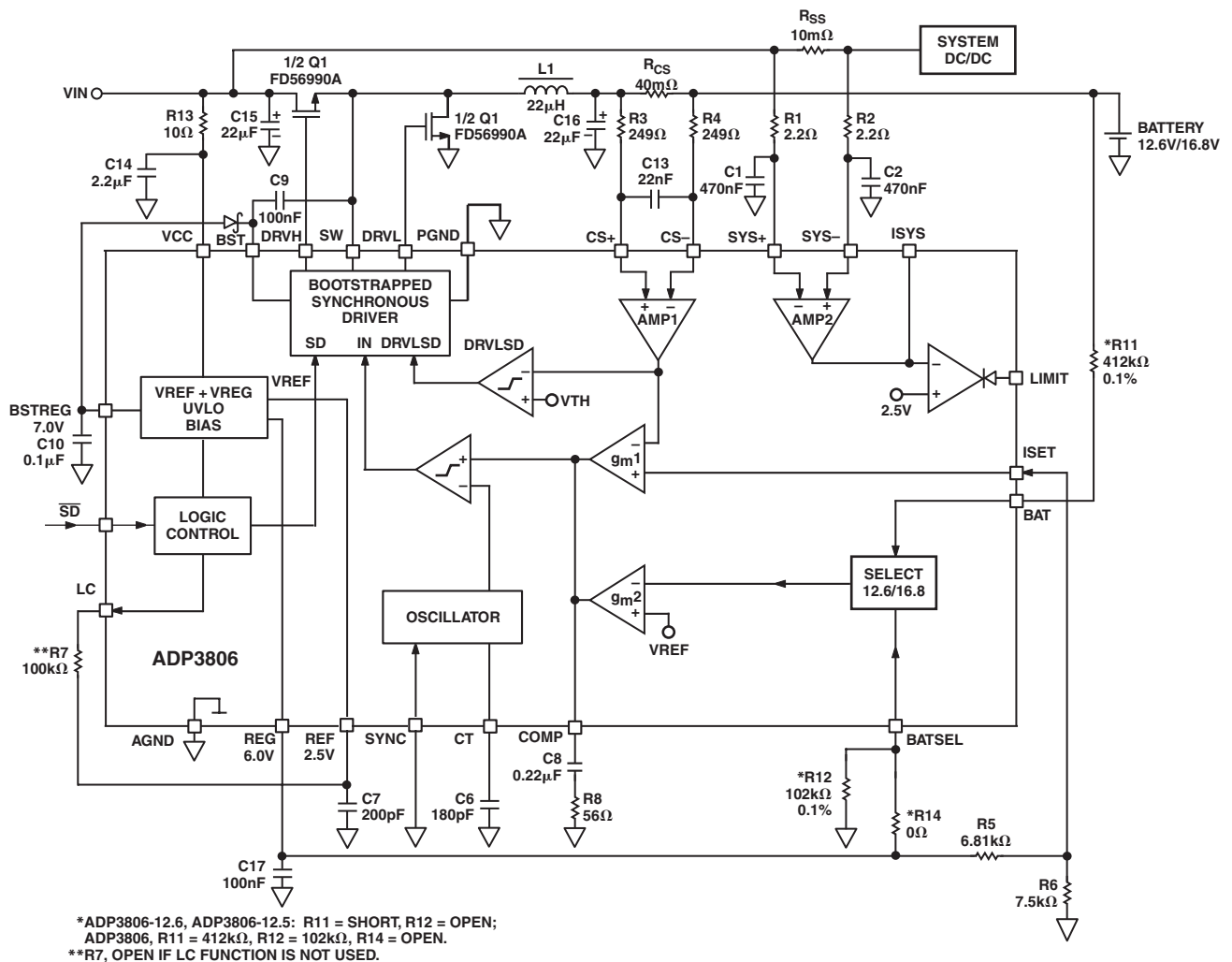

Figure 1. Typical Application

# ADP3806

Typical values of  $R_{CS}$  range from 25 m $\Omega$  to 50 m $\Omega$ , and the input range of ISET is from 0 V to 4 V. If, for example, a 3 A charger is required,  $R_{CS}$  could be set to 40 m $\Omega$  and  $V_{ISET} = 3$  V. The power dissipation in  $R_{CS}$  should be kept below 500 mW. In this example, the power is a maximum of 360 mW. Once  $R_{CS}$  has been chosen, the charge current can be adjusted during operation with  $V_{ISET}$ . Lowering  $V_{ISET}$  to 125 mV gives a charge current of 125 mA for trickle charging. Components R3, R4, and C13 provide high frequency filtering for the current sense signal.

## Final Battery Voltage Control

As the battery approaches its final voltage, the ADP3806 switches from CC mode to CV mode. The change is achieved by the common output node of  $g_{m1}$  and  $g_{m2}$ . Only one of the two outputs controls the voltage at the COMP pin. Both amplifiers can only pull down on COMP, such that when either amplifier has a positive differential input voltage, its output is not active. For example, when the battery voltage,  $V_{BAT}$ , is low,  $g_{m2}$  does not control  $V_{COMP}$ . When the battery voltage reaches the desired final voltage,  $g_{m2}$  takes control of the loop, and the charge current is reduced.

Amplifier  $g_{m2}$  compares the battery voltage to the internal reference voltage of 2.5 V. In the case of the ADP3806-12.5 and ADP3806-12.6, an internal resistor divider sets the selectable final battery voltage.

When BATSEL is high, the final battery voltage is set to three cells (12.6 V or 12.525 V). BATSEL can be tied to REG for this state. When BATSEL is tied to ground,  $V_{BAT}$  equals four cells (16.8 V or 16.7 V). BATSEL has a 2  $\mu$ A pull-up current as a fail-safe to select three cells when it is left open.

The reference and internal resistor divider are referenced to the AGND pin, which should be connected close to the negative terminal of the battery to minimize sensing errors.

In contrast, the ADP3806 requires external, precision resistors. The divider ratio should be set to divide the desired final voltage down to 2.5 V at the BAT pin

$$\frac{R11}{R12} = \frac{V_{BATTERY}}{2.5V} - 1 \quad (2)$$

These resistors should have a parallel impedance of approximately 80 k $\Omega$  to minimize bias current errors. When the ADP3806 is in shutdown, an internal switch disconnects the BAT pin as shown in Figure 2. This disconnects the resistor, R11, from the battery and minimizes leakage. The resistance of the internal switch is less than 200  $\Omega$ .

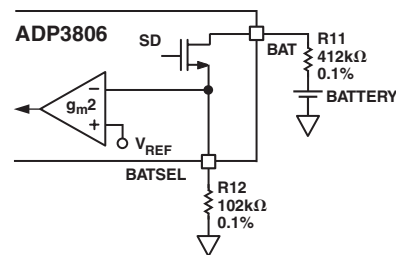

Figure 2. Battery Sense Disconnect Circuit

## Oscillator and PWM

The oscillator generates a triangle waveform between 1 V and 2.5 V, which is compared to the voltage at the COMP pin, setting the duty cycle of the driver stage. When  $V_{COMP}$  is below 1 V, the duty cycle is zero. Above 2.5 V, the duty cycle reaches its maximum.

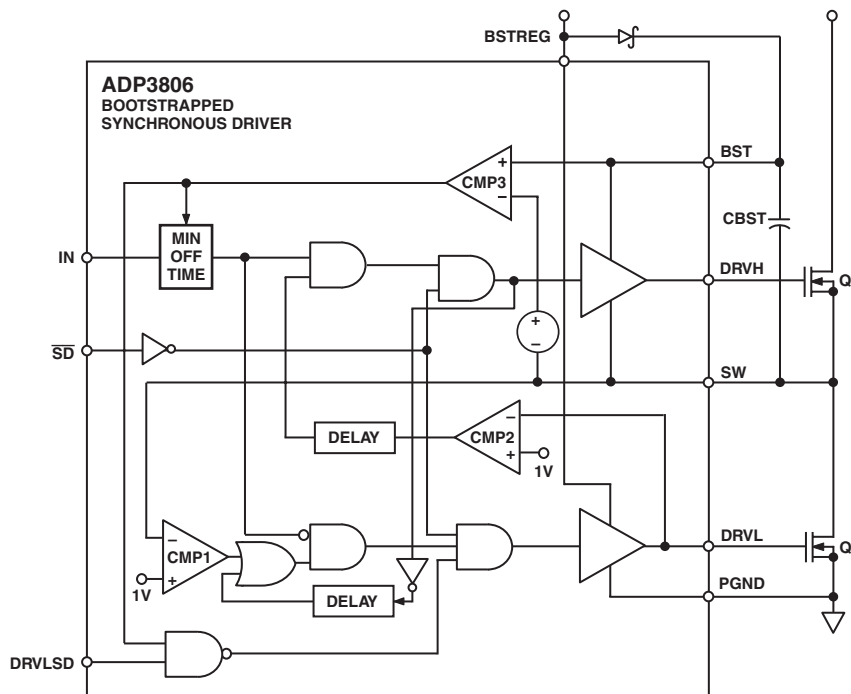

Figure 3. Bootstrapped Synchronous Driver

The oscillator frequency is set by the external capacitor at the CT pin and the internal current source of 150  $\mu\text{A}$  according to the following formula:

$$f_{osc} = \frac{150 \mu\text{A}}{2.2 \times Cr \times 1.5V} \quad (3)$$

A 180 pF capacitor sets the frequency to 250 kHz. The frequency can also be synchronized to an external oscillator by applying a square wave input on SYNC. The SYNC function is designed to allow increases only in the oscillator frequency. The  $f_{SYNC}$  should be no more than 20% higher than  $f_{OSC}$ . The duty cycle of the SYNC input is not important and can be anywhere between 5% and 95%.

### 7 V Bootstrap Regulator

The driver stage is powered by the internal 7 V bootstrap regulator, which is available at the BSTREG pin. Because the switching currents are supplied by this regulator, decoupling must be added. A 0.1  $\mu\text{F}$  capacitor should be placed close to the ADP3806, with the ground side connected close to the power ground pin, PGND. This supply is not recommended for use externally due to high switching noise.

### Bootstrapped Synchronous Driver

The PWM comparator controls the state of the synchronous driver shown in Figure 3. A high output from the PWM comparator forces DRVH on and DRVL off. The drivers have an on resistance of approximately 6  $\Omega$  for fast rise and fall times when driving external MOSFETs. Furthermore, the bootstrapped drive allows an external NMOS transistor for the main switch instead of a PMOS. An external boost diode should be connected between BSTREG and BST, and a boost capacitor of 0.1  $\mu\text{F}$  must be added externally between BST and SW. The voltage between BST and SW is typically 6.5 V.

The DRVL pin switches between BSTREG and PGND. The 7 V output of BSTREG drives the external NMOS with high VGS to lower the on resistance. PGND should be connected close to the source pin of the external synchronous NMOS. When DRVL is high, this turns on the lower NMOS and pulls the SW node to ground. At this point, the boost capacitor is charged up through the boost diode. When the PWM switches high, DRVL is turned off and DRVH turns on. DRVH switches between BST and SW. When DRVH is on, the SW pin is pulled up to the input supply (typically 16 V), and BST rises above this voltage by approximately 6.5 V.

Overlap protection is included in the driver to ensure that both external MOSFETs are not on at the same time. When DRVH turns off the upper MOSFET, the SW node goes low due to the inductor current. The ADP3806 monitors the SW voltage, and DRVL goes high to turn on the lower MOSFET when SW goes below 1 V. When DRVL turns off, an internal timer adds a delay of 50 ns before turning DRVH on.

When the charge current is low, the DRVLSD comparator signals the driver to turn off the low side MOSFET and DRVL is held low. As shown in Figure 1, the DRVLSD comparator looks at the output of AMP1. The DRVLSD threshold is set to 1.2 V, corresponding to 48 mV differential voltage between the CS pins.

The driver stage monitors the voltage across the BST capacitor with CMP3. When this voltage is less than 4 V, CMP3 forces a minimum offtime of 200 ns. This ensures that the BST capacitor is charged even during DRVLSD. However, because a minimum off time is only forced when needed, the maximum duty cycle is greater than 99%.

### 2.5 V Precision Reference

The voltage at the BAT pin is compared to an internal precision, low temperature drift reference of 2.5 V. The reference is available externally at the REF pin. This pin should be bypassed with a 100 pF capacitor to the analog ground pin, AGND. The reference can be used as a precision voltage externally. However, the current draw should not be greater than 100  $\mu\text{A}$ , and noisy, switching type loads should not be connected.

### 6 V Regulator

The 6 V regulator supplies power to most of the analog circuitry on the ADP3806. This regulator should be bypassed to AGND with a 0.1  $\mu\text{F}$  capacitor. This reference has a 3 mA source capability to power external loads if needed.

### LC

The ADP3806 provides a low current (LC) logic output to signal when the current sense voltage ( $V_{CS}$ ) is below a fixed threshold and the battery voltage is greater than 95%. LC is an open-drain output that is pulled low when  $V_{CS}$  is above the threshold. When the low current threshold condition is reached, LC is pulled high by an external resistor to REF or another appropriate pull-up voltage. To determine when LC goes low, an internal comparator senses when the current falls below 12.5% of full scale (20 mV across the CS pins). The comparator has hysteresis to prevent oscillation around the trip point.

To prevent false triggering (such as during soft-start), the comparator is only enabled when the battery voltage is within 5% of its final voltage. As the battery is charging up, the comparator will not go low even if the current falls below 12.5% as long as the battery voltage is below 95% of full scale. Once the battery has risen above 95%, the comparator is enabled. This pin can be used to indicate the end of the charge process.

### System Current Sense

An uncommitted differential amplifier is provided for additional high side current sensing. This amplifier, AMP2, has a fixed gain of 50 V/V from the SYS+ and SYS- pins to the analog output at ISYS. ISYS has a 1 mA source capability to drive an external load. The common-mode range of the input pins is from 4 V to VCC. This amplifier is the only part of the ADP3806 that remains active during shutdown. The power to this block is derived from the bias current on the SYS+ and SYS- pins.

A separate comparator at the LIMIT pin signals when the voltage on the ISYS pin exceeds 2.5 V typically. The internal comparator has an open-drain output, which produces the function shown in the TPC 10 graph of  $V_{LIMIT}$  versus  $V_{ISYS}$ . The LIMIT pin should be externally pulled up to 5 V, 2.5 V, or some other voltage as needed through a resistor. This graph was taken with a 50 k $\Omega$  pull-up resistor to 5 V and to 2.5 V. When ISYS is below 2.4 V, the LIMIT pin has high output impedance. The open-drain output is capable of sinking 700  $\mu\text{A}$  when the threshold is exceeded. This comparator is turned off during shutdown to conserve power.

# ADP3806

## Shutdown

A high impedance CMOS logic input is provided to turn off the ADP3806. When the voltage on  $\overline{SD}$  is less than 0.8 V, the ADP3806 is placed in low power shutdown. With the exception of the system current sense amplifier, AMP2, all other circuitry is turned off. The reference and regulators are pulled to ground during shutdown and all switching is stopped. During this state, the supply current is less than 5  $\mu$ A. Also, the BAT, CS+, CS-, and SW pins go to high impedance to minimize current drain from the battery.

## UVLO

Undervoltage lock-out, UVLO, is included in the ADP3806 to ensure proper startup. As VCC rises above 1 V, the reference and regulators will track VCC until they reach their final voltages. However, the rest of the circuitry is held off by the UVLO comparator. The UVLO comparator monitors both regulators to ensure that they are above 5 V before turning on the main charger circuitry. This occurs when VCC reaches 6 V. Monitoring the regulator outputs makes sure that the charger circuitry and driver stage have sufficient voltage to operate normally. The UVLO comparator includes 300 mV of hysteresis to prevent oscillations near the threshold.

## Startup Sequence

During a startup from either  $\overline{SD}$  going high or VCC exceeding the UVLO threshold, the ADP3806 initiates a soft-start sequence. The soft-start timing is set by the compensation capacitor at the COMP pin and an internal 40  $\mu$ A source. Initially, both DRVH and DRVL are held low until VCOMP reaches 1 V. This delay time is set by

$$t_{DELAY} = \frac{C_{COMP} \times 1V}{40 \mu A} \quad (4)$$

For a 0.22  $\mu$ F COMP capacitor,  $t_{DELAY}$  is 5 ms. After this initial delay, the duty cycle is very low and then ramps up to its final value with the same ramp rate given for  $t_{DELAY}$ . For example, if  $V_{IN}$  is 16 V and the battery is 10 V when charging is started, the duty cycle will be approximately 65%, corresponding to a  $V_{COMP}$  of ~2 V. The time for the duty cycle to ramp from 0% at  $V_{COMP} = 1$  V to 65% at  $V_{COMP} = 2$  V is approximately 5 ms. Because the charge current is equal to zero at first, DRVLS is active and DRVL will not turn on. However, if the BST capacitor is discharged, DRVL will be forced on for a minimum on time of 200 ns each clock period until the BST capacitor is charged to greater than 4 V. Typically the BST capacitor is charged in five to ten clock cycles.

## Loop Feed Forward

As the startup sequence discussion shows, the response time at COMP is slowed by the large compensation capacitor. To speed up the response, two comparators can quickly feed forward around the normal control loop and pull the COMP node down to limit any overshoot in either short-circuit or overvoltage conditions. The overvoltage comparator has a trip point set to 20% higher than the final battery voltage. The overcurrent comparator threshold is set to 180 mV across the CS pins, which is 15% above the maximum programmable threshold. When these comparators are tripped, a normal soft-start sequence is initiated. The overvoltage comparator is valuable when the battery is removed during charging. In this case, the current in the inductor causes the output voltage to spike up, and the comparator limits the maximum voltage. Neither of these comparators affects the loop under normal charging conditions.

## APPLICATION INFORMATION

### Design Procedure

Refer to Figure 1, the typical application circuit, for the following description. The design follows that of a buck converter. With Li-Ion cells it is important to have a regulator with accurate output voltage control.

### Battery Voltage Settings

The ADP3806 has three options for voltage selection:

1. 12.525 V/16.7 V as selectable fixed voltages
2. 12.6 V/16.8 V as selectable fixed voltages
3. Adjustable

When using the fixed versions, R11 should be a short or 0  $\Omega$  wire jumper and R12 should be an open circuit. When using the adjustable version, the following equation gives the ratio of the two resistors:

$$\frac{R11}{R12} = \left( \frac{V_{BAT}}{2.5} \right) - 1 \quad (5)$$

Often 0.1% resistors are required to maintain the overall accuracy budget in the design.

### Inductor Selection

Usually the inductor is chosen based on the assumption that the inductor ripple current is  $\pm 15\%$  of the maximum output dc current at maximum input voltage. As long as the inductor used has a value close to this, the system should work fine. The final choice affects the trade-offs between cost, size, and efficiency. For example, the lower the inductance, the size is smaller but ripple current is higher. This situation, if taken too far, will lead to higher ac losses in the core and the windings. Conversely, a higher inductance results in lower ripple current and smaller output filter capacitors, but the transient response will be slower. With these considerations, the required inductance can be found from

$$L1 = \frac{V_{IN,MAX} - V_{BAT}}{\Delta I} \times D_{MIN} \times T_S \quad (6)$$

where the maximum input voltage  $V_{IN,MAX}$  is used with the minimum duty ratio  $D_{MIN}$ . The duty ratio is defined as the ratio of the output voltage to the input voltage,  $V_{BAT}/V_{IN}$ . The ripple current is found from

$$\Delta I = 0.3 \times I_{BAT,MAX} \quad (7)$$

the maximum peak-to-peak ripple is 30%, that is 0.3, and maximum battery current,  $I_{BAT,MAX}$ , is used.

For example, with  $V_{IN,MAX} = 19$  V,  $V_{BAT} = 12.6$  V,  $I_{BAT,MAX} = 3$  A, and  $T_S = 4$   $\mu$ s, the value of L1 is calculated as 18.9  $\mu$ H. Choosing the closest standard value gives L1 = 22  $\mu$ H.

### Output Capacitor Selection

An output capacitor is needed in the charger circuit to absorb the switching frequency ripple current and smooth the output voltage. The rms value of the output ripple current is given by

$$I_{rms} = \frac{V_{IN,MAX}}{fL1\sqrt{12}} D(1-D) \quad (8)$$

The maximum value occurs when the duty cycle is 0.5. Thus

$$I_{rms,MAX} = 0.072 \frac{V_{IN,MAX}}{fL1} \quad (9)$$

For an input voltage of 19 V and a 22  $\mu\text{H}$  inductance, the maximum rms current is 0.26 A. A typical 10  $\mu\text{F}$  or 22  $\mu\text{F}$  ceramic capacitor is a good choice to absorb this current.

#### Input Capacitor Ripple

As is the case with a normal buck converter, the pulse current at the input has a high rms component. Therefore, since the input capacitor has to absorb this current ripple, it must have an appropriate rms current rating. The maximum input rms current is given by

$$I_{rms} = \frac{P_{BAT}}{\eta \times D \times V_{IN}} \times \frac{\sqrt{D(1-D)}}{D} \quad (10)$$

where  $\eta$  is the estimated converter efficiency (approximately 90%, 0.9) and  $P_{BAT}$  is the maximum battery power consumed. This is a worst-case calculation and, depending on total charge time, the calculated number could be relaxed. Consult the capacitor manufacturer for further technical information.

#### Decoupling the VCC Pin

It is a good idea to use an RC filter (R13 and C14) from the input voltage to the IC both to filter out switching noise and to supply bypass to the chip. During layout, this capacitor should be placed as close to the IC as possible. Values between 0.1  $\mu\text{F}$  and 2.2  $\mu\text{F}$  are recommended.

#### Current-Sense Filtering

During normal circuit operation, the current-sense signals can have high frequency transients that need filtering to ensure proper operation. In the case of the CS+ and CS- inputs, the resistors (R3 and R4) are set to 249  $\Omega$  while the filter capacitor (C13) value is 22 nF. For the system current sense circuits, common-mode filtering from SYS+ and SYS- to ground is needed. 470 nF ceramic capacitors (C1, C2) with 2.2  $\Omega$  resistors (R1, R2) will often do. These time constants can be adjusted in the laboratory if required but represent a good starting point.

#### MOSFET Selection

One of the features of the ADP3806 is that it allows use of a high side NMOS switch instead of a more costly PMOS device. The converter also uses synchronous rectification for optimal efficiency. In order to use a high side NMOS, an internal bootstrap regulator automatically generates a 7 V supply across C9.

Maximum output current determines the  $R_{DS(ON)}$  requirement for the two power MOSFETs. When the ADP3806 is operating in continuous mode, the simplifying assumption can be made that one of the two MOSFETs is always conducting the load current. The power dissipation for each MOSFET is given by:

Upper MOS

$$P_{DISS} = R_{DS(ON)} \times (I_{BAT} \times \sqrt{D})^2 + V_{IN} \times I_{BAT} \times \sqrt{D} \times T_{SW} \times f \quad (11)$$

Lower MOS

$$P_{DISS} = R_{DS(ON)} \times (I_{BAT} \times \sqrt{1-D})^2 + V_{IN} \times I_{BAT} \times \sqrt{1-D} \times T_{SW} \times f \quad (12)$$

where  $f$  is the switching frequency and  $T_{SW}$  is the switch transition time, usually 10 ns. The first term accounts for conduction losses while the second term estimates switching losses. Using these equations and the manufacturer's data sheets, the proper device can be selected.

A Schottky diode, D1, in parallel with Q2 conducts only during dead time between the two power MOSFETs. D1's purpose is to prevent the body diode of the lower N-channel MOSFET from turning on, which could cost as much as 1% in efficiency. One option is to use a combined MOSFET with the Schottky diode in a single package; these integrated packages often work better in practice. Examples are the IRF7807D2 and the Si4832.

## OUTLINE DIMENSIONS

### 24-Lead Thin Shrink Small Outline Package [TSSOP] (RU-24)

Dimensions shown in millimeters

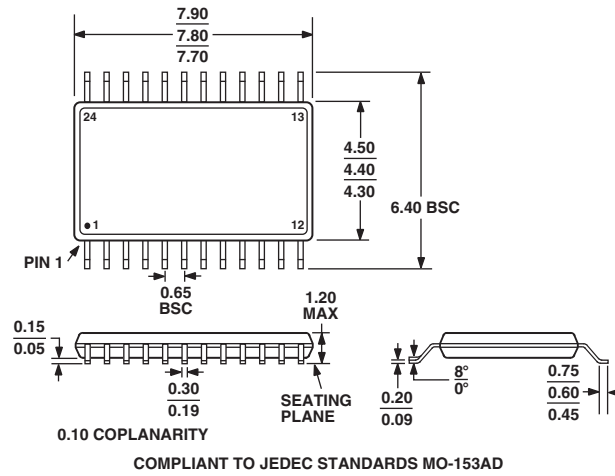

## Revision History

<b>Location</b>	<b>Page</b>
<b>2/04—Data Sheet changed from REV. A to REV. B.</b>	
Changes to SPECIFICATIONS .....	2
Changes to ORDERING GUIDE .....	4
Updated OUTLINE DIMENSIONS .....	14
<b>6/03—Data Sheet changed from REV. 0 to REV. A.</b>	
Updated SPECIFICATIONS .....	2
Updated ABSOLUTE MAXIMUM RATINGS .....	4
Changes to ORDERING GUIDE .....	4
Updated OUTLINE DIMENSIONS .....	14



## Looking for pricing, stock, or lifecycle information?

Click below to explore more details on WIN SOURCE:

- ⊖ [View ADP3806JRU-REEL7 on WIN SOURCE](#)
- ⊖ [Analog Devices Inc. Information](#)

## Optimize Your Supply Chain with WIN SOURCE Solutions

- ✓ Global Sourcing Solution
- ✓ Obsolete Management
- ✓ Cost Control Management
- ✓ Shortage Management
- ✓ Alternative Solution
- ✓ Excess Inventory Management