



**THE DATASHEET OF  
BQ24765RUVR**



# bq24765 SMBus-Controlled Multi-Chemistry Battery Charger With Integrated Power MOSFETs

## 1 Features

- Integrated Power MOSFETs, NMOS-NMOS, Synchronous Buck Converter
- >95% Efficiency
- Frequency 700kHz Allows Smaller Inductor (5 mm x 5 mm)
- Thermal Regulation Loop for Safety, Limit  $T_J = 120^\circ\text{C}$
- Adaptive Driver Dead-time and 99.5% Maximum Effective Duty Cycle
- High-Accuracy Voltage and Current Regulation
  - $\pm 0.5\%$  Charge Voltage Accuracy
  - $\pm 3\%$  Charge Current Accuracy
  - $\pm 3\%$  Adapter Current Accuracy
  - $\pm 2\%$  Input Current Sense Amp Accuracy
- Integration
  - Integrated Power MOSFETs
  - Input Current Comparator
  - Internal Soft-Start
- Safety
  - Thermal Regulation Loop and Thermal Shutdown
  - Dynamic Power Management (DPM)
  - Power FETs Over Current Protection
- 7 V–24 V AC/DC-Adapter Operating Range
- Simplified SMBus Control
  - Charge Voltage DAC (1.024 V–19.2 V)
  - Charge Current DAC (128 mA–8.064 A)
  - Adapter Current Limit DPM DAC (256 mA–11.008 A)
- Status and Monitoring Outputs
  - AC/DC Adapter Present With Adjustable Voltage Threshold
  - Input Current Comparator, With Adjustable Threshold and Hysteresis
  - Current Sense Amplifier for Current Drawn From Input Source
- Charge Any Battery Chemistry: Li+, LiFePO<sub>4</sub>, NiCd, NiMH, Lead Acid (2, 3, and 4 Li-Ion Cells)
- Charge Enable Pin (CE)
- Energy Star Low I<sub>q</sub>
  - < 10- $\mu\text{A}$  Battery Current with Adapter Removed
  - < 1 mA Input DCINA Current When Adapter

Present and Charge Disabled

- 34-pin, 3.50 mm x 7.00 mm QFN Package

## 2 Applications

- Notebook and Ultra-Mobile Computers
- Portable Data-Capture Terminals
- Portable Printers
- Medical Diagnostics Equipment
- Battery Bay Chargers
- Battery Back-up Systems

## 3 Description

The bq24765 is a high-efficiency, synchronous battery charger with two integrated 30-m $\Omega$  NMOS power MOSFETs, and an integrated input current comparator, offering low component count for space-constraint, multi-chemistry battery charging applications. Input current, charge current, and charge voltage DACs allow for very high regulation accuracies that can be easily programmed by the system power management micro-controller using SMBus. The bq24765 has switching frequency of 700 kHz. The bq24765 charges 2, 3, or 4 series Li+ cells, and is available in a 34-pin, 3.50 mm x 7.00 mm VQFN package.

### Device Information<sup>(1)</sup>

PART NUMBER	PACKAGE	BODY SIZE (NOM)
bq24765	VQFN (34)	3.50 mm x 7.00 mm

(1) For all available packages, see the orderable addendum at the end of the data sheet.

### Simplified Schematic

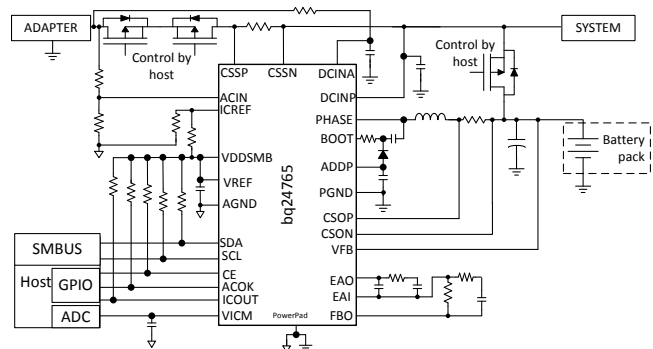

## Table of Contents

<b>1 Features</b> .....	<b>1</b>	8.4 Device Functional Modes.....	<b>21</b>
<b>2 Applications</b> .....	<b>1</b>	8.5 Programming.....	<b>21</b>
<b>3 Description</b> .....	<b>1</b>	8.6 Register Maps .....	<b>25</b>
<b>4 Revision History</b> .....	<b>2</b>	<b>9 Application and Implementation</b> .....	<b>28</b>
<b>5 Description (Continued)</b> .....	<b>3</b>	9.1 Application Information.....	<b>28</b>
<b>6 Pin Configuration and Functions</b> .....	<b>3</b>	9.2 Typical Application .....	<b>28</b>
<b>7 Specifications</b> .....	<b>5</b>	<b>10 Power Supply Recommendations</b> .....	<b>33</b>
7.1 Absolute Maximum Ratings .....	<b>5</b>	<b>11 Layout</b> .....	<b>33</b>
7.2 ESD Ratings.....	<b>5</b>	11.1 Layout Guidelines .....	<b>33</b>
7.3 Recommended Operating Conditions.....	<b>6</b>	11.2 Layout Example .....	<b>34</b>
7.4 Thermal Information .....	<b>6</b>	<b>12 Device and Documentation Support</b> .....	<b>35</b>
7.5 Electrical Characteristics.....	<b>7</b>	12.1 Device Support.....	<b>35</b>
7.6 SMB Timing Requirements .....	<b>10</b>	12.2 Documentation Support .....	<b>35</b>
7.7 Typical Characteristics .....	<b>12</b>	12.3 Community Resources.....	<b>35</b>
<b>8 Detailed Description</b> .....	<b>14</b>	12.4 Trademarks .....	<b>35</b>
8.1 Overview .....	<b>14</b>	12.5 Electrostatic Discharge Caution.....	<b>35</b>
8.2 Functional Block Diagram .....	<b>15</b>	12.6 Glossary .....	<b>35</b>
8.3 Feature Description.....	<b>16</b>	<b>13 Mechanical, Packaging, and Orderable Information</b> .....	<b>36</b>

## 4 Revision History

NOTE: Page numbers for previous revisions may differ from page numbers in the current version.

### Changes from Original (November 2009) to Revision A

Page

- Added *ESD Ratings* table, *Feature Description* section, *Device Functional Modes*, *Application and Implementation* section, *Power Supply Recommendations* section, *Layout* section, *Device and Documentation Support* section, and *Mechanical, Packaging, and Orderable Information* section .....
- Deleted Ordering Information table .....

## 5 Description (Continued)

The bq24765 features Dynamic Power Management (DPM) and input power limiting. These features reduce battery charge current when the input power limit is reached to avoid overloading the AC adaptor when supplying the load and the battery charger simultaneously. A high-accuracy current sense amplifier enables accurate measurement of input current from the AC adapter, allowing monitoring the overall system power. If the adapter current is above the programmed low-power threshold, a signal is sent to host so that the system optimizes its power performance according to what is available from the adapter. An integrated comparator allows monitoring the input current through the current sense amplifier, and indicating when the input current exceeds a programmable threshold limit. The bq24765 features a thermal regulation loop to reduce battery charge current when the  $T_j$  limit is reached. This feature protects internal power FETs from overheating when charging with high current.

## 6 Pin Configuration and Functions

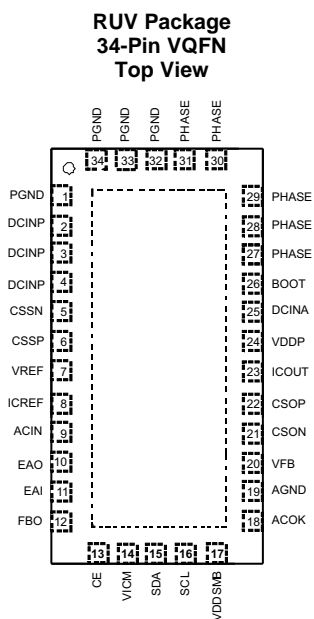

**Pin Functions**

PIN		TYPE	DESCRIPTION
NAME	NO.		
ACIN	9	I	Adapter detected voltage set input. Program the adapter detect threshold by connecting a resistor divider from adapter input to ACIN pin to AGND pin. ACOK open-drain output is pulled high and charge is allowed when ACIN pin voltage is greater than 2.4V. VREF regulator and VICM current sense amplifier are active when ACIN pin voltage is greater than 0.6V, and $DCINA > V_{DCIN\_UVLO}$ .
ACOK	18	O	Valid adapter active-high detect logic open-drain output. Pulled HI when Input voltage is above ACIN programmed threshold and DCINA is above UVLO threshold. Connect a 10-k $\Omega$ pull-up resistor from ACOK pin to pull-up supply rail.
AGND	19	AGND	Analog Ground. On PCB layout, connect to the analog ground plane, and only connect to PGND through the power-pad underneath the IC.
BOOT	26	P	PWM high side driver positive supply. Connect a 0.1 $\mu$ F bootstrap ceramic capacitor from BOOT to PHASE. Connect a small bootstrap Schottky diode from VDDP to BOOT.
CE	13	I	Charge enable active-high logic input. HI enables charge. LO disables charge. Pull up CE using 10kOhm resistor or connect directly to VREF to enable charger.
CSON	21	P	Charge current sense resistor, negative input. An optional 0.1- $\mu$ F ceramic capacitor is placed from CSON pin to AGND for common-mode filtering. A 0.1- $\mu$ F ceramic capacitor is placed from CSON to CSOP to provide differential-mode filtering. The capacitor of the output LC filter is placed on CSON.
CSOP	22	P	Charge current sense resistor, positive input. A 0.1- $\mu$ F ceramic capacitor is placed from CSOP pin to AGND for common mode filtering. A 0.1- $\mu$ F ceramic capacitor is placed from CSON to CSOP to provide differential-mode filtering.

**Pin Functions (continued)**

PIN		TYPE	DESCRIPTION
NAME	NO.		
CSSN	5	P	Adapter current sense resistor, negative input. An optional 0.1-uF ceramic capacitor is placed from CSSN pin to AGND for common-mode filtering. A 0.1-uF ceramic capacitor is placed from CSSN to CSSP to provide differential-mode filtering.
CSSP	6	P	Adapter current sense resistor, positive input. A 0.1-uF ceramic capacitor is placed from CSSP pin to AGND for common-mode filtering. A 0.1-uF ceramic capacitor is placed from CSSN to CSSP to provide differential-mode filtering.
DCINA	25	P	Analog sense of IC power positive supply for internal reference bias circuit. Connect directly to adapter input, or to diode-OR point of adapter and battery. Place a 20Ω and 0.5uF ceramic capacitor filter from adapter to AGND pin close to the IC and connect to DCINA on the node between the resistor and capacitor.
DCINP	2	P	High current input for IC power positive supply, and connection to drain of high-side power MOSFET. Place two 10uF ceramic capacitors from DCINP to PGND pin close to the IC.
DCINP	3	P	High current input for IC power positive supply, and connection to drain of high-side power MOSFET. Place two 10uF ceramic capacitors from DCINP to PGND pin close to the IC.
DCINP	4	P	High current input for IC power positive supply, and connection to drain of high-side power MOSFET. Place two 10uF ceramic capacitors from DCINP to PGND pin close to the IC.
EAI	11	I	Error Amplifier Input for compensation. Connect the feedback compensation components from EAI to EAO. Connect the input compensation from FBO to EAI.
EAO	10	I	Error Amplifier Output for compensation. Connect the feedback compensation components from EAO to EAI. Typically, a capacitor in parallel with a series resistor and capacitor. This node is internally compared to the PWM saw-tooth oscillator signal.
FBO	12	O	Feedback Output for compensation. Connect the input compensation from FBO to EAI. Typically, a resistor in parallel with a series resistor and capacitor.
ICOUT	23	O	Low power mode detect active-high open-drain logic output. Place a 10kohm pull-up resistor from ICOUT pin to the pull-up voltage rail. Place a positive feedback resistor from ICOUT pin to ICREF pin for programming hysteresis. The output is HI when VICM pin voltage is lower than ICREF pin voltage. The output is LO when VICM pin voltage is higher than ICREF pin voltage.
ICREF	8	I	Low power voltage set input. Connect a resistor divider from VREF to ICREF, and AGND to program the reference for the LOPWR comparator. The ICREF pin voltage is compared to the VICM pin voltage and the logic output is given on the ICOUT open-drain pin. Connecting a positive feedback resistor from ICREF pin to ICOUT pin programs the hysteresis.
PGND	1	PGND	Power ground. Connection to source of integrated low-side power MOSFET. On PCB layout, connect to ground connection of input and output capacitors of the charger. Only connect to AGND through the power-pad underneath the IC.
PGND	32	PGND	Power ground. Connection to source of integrated low-side power MOSFET. On PCB layout, connect to ground connection of in put and out put capacitors of the charger. Only connect to AGND through the power-pad underneath the IC.
PGND	33	PGND	Power ground. Connection to source of integrated low-side power MOSFET. On PCB layout, connect to ground connection of in put and out put capacitors of the charger. Only connect to AGND through the power-pad underneath the IC
PGND	34	PGND	Power ground. Connection to source of integrated low-side power MOSFET. On PCB layout, connect to ground connection of in put and out put capacitors of the charger. Only connect to AGND through the power-pad underneath the IC.
PHASE	28	P	Phase switching node (junction of the integrated high-side power MOSFET source and the integrated low-side power MOSFET drain). Connect to the output inductor. Connect the 0.1uF bootstrap ceramic capacitor from PHASE to BOOT
PHASE	27	P	Phase switching node (junction of the integrated high-side power MOSFET source and the integrated low-side power MOSFET drain). Connect to the output inductor. Connect the 0.1uF bootstrap ceramic capacitor from PHASE to BOOT.
PHASE	29	P	Phase switching node (junction of the integrated high-side power MOSFET source and the integrated low-side power MOSFET drain). Connect to the output inductor. Connect the 0.1uF bootstrap ceramic capacitor from PHASE to BOOT
PHASE	30	P	Phase switching node (junction of the integrated high-side power MOSFET source and the integrated low-side power MOSFET drain). Connect to the output inductor. Connect the 0.1uF bootstrap ceramic capacitor from PHASE to BOOT.
PHASE	31	P	Phase switching node (junction of the integrated high-side power MOSFET source and the integrated low-side power MOSFET drain). Connect to the output inductor. Connect the 0.1uF bootstrap ceramic capacitor from PHASE to BOOT.

### Pin Functions (continued)

PIN		TYPE	DESCRIPTION
NAME	NO.		
SCL	16	I	SMBus Clock input. Connect to SMBus clock line from the host controller. A 10-kohm pull-up resistor to the host controller power rail is needed.
SDA	15	I	SMBus Data input. Connect to SMBus data line from the host controller. A 10-kohm pull-up resistor to the host controller power rail is needed.
VDDP	24	P	PWM low side driver positive 6V supply output. Connect a 1uF ceramic capacitor from VDDP to PGND pin, close to the IC. Use for high-side driver bootstrap voltage by connecting a small signal Schottky diode from VDDP to BOOT.
VDDSMB	17	I	Input voltage for SMBus logic. Connect a 3.3V always supply rail, or 5V always rail to VDDSMB pin. Connect a 0.1uF ceramic capacitor from VDDSMB to AGND for decoupling.
VFB	20	I	Battery voltage remote sense. Directly connect a Kelvin sense trace from the battery pack positive terminal to the VFB pin to accurately sense the battery pack voltage. Place a 0.1-uF capacitor from VFB to AGND close to the IC to filter high frequency noise.
VICM	14	O	Adapter current sense amplifier output. VICM voltage is 20 times the differential voltage across CSSP-CSSN. Place a 100pF (max) or less ceramic decoupling capacitor from VICM to AGND.
VREF	7	P	3.3V regulated voltage output. Place a 1uF ceramic capacitor from VREF to AGND pin close to the IC. This voltage could be used for programming the ICREF threshold. VREF can directly connect to VDDSMB as SMBus supply, or serve as pull up supply rail for CE, ACOK and ICOUT.
Power Pad		GND	Exposed pad beneath the IC. AGND and PGND star-connected only at the Power Pad plane. Always solder Power Pad to the board, and have vias on the Power Pad plane connecting to AGND and PGND planes. It also serves as a thermal pad to dissipate heat.

## 7 Specifications

### 7.1 Absolute Maximum Ratings

over operating free-air temperature range (unless otherwise noted)<sup>(1)(2)</sup>

		MIN	MAX	UNIT
Voltage	DCINP, DCINA, CSOP, CSON, CSSP, CSSN, VFB, ACOK	-0.3	30	V
	PHASE	-1	30	
	EAI, EAO, FBO, VDDP, ACIN, VICM, ICOUT, ICREF, CE	-0.3	7	
	VDDSMB, SDA, SCL	-0.3	6	
	VREF	-0.3	3.6	
	BOOT (with respect to AGND and PGND)	-0.3	36	
Maximum difference voltage: CSOP-CSON, CSSP-CSSN		-0.5	0.5	V
Operating junction temperature, T <sub>J</sub>		-40	155	°C
Storage temperature, T <sub>stg</sub>		-55	155	°C

- (1) Stresses beyond those listed under *Absolute Maximum Ratings* may cause permanent damage to the device. These are stress ratings only, which do not imply functional operation of the device at these or any other conditions beyond those indicated under *Recommended Operating Conditions*. Exposure to absolute-maximum-rated conditions for extended periods may affect device reliability.
- (2) All voltages are with respect to AGND and PGND if not specified. Currents are positive into, and negative out of the specified terminal. Consult Packaging Section of the data book for thermal limitations and considerations of packages.

### 7.2 ESD Ratings

		VALUE	UNIT
V <sub>(ESD)</sub> Electrostatic discharge	Human-body model (HBM), per ANSI/ESDA/JEDEC JS-001 <sup>(1)</sup>	±2000	V
	Charged-device model (CDM), per JEDEC specification JESD22-C101 <sup>(2)</sup>	±500	

- (1) JEDEC document JEP155 states that 500-V HBM allows safe manufacturing with a standard ESD control process.
- (2) JEDEC document JEP157 states that 250-V CDM allows safe manufacturing with a standard ESD control process.

### 7.3 Recommended Operating Conditions

		MIN	NOM	MAX	UNIT
Voltage	PHASE	-1		24	V
	DCINP, DCINA, CSOP, CSON, CSSP, CSSN, VFB, ACOK	0		24	
	VDDP	0		6.5	
	VREF			3.3	
	VDDSMB, SDA, SCL	0		5.5	
	EAI, EAO, FBO, ACIN, VICM, ICOUT, ICREF, CE	0		5.5	
	BOOT (with respect to GND and PGND)	0		30	
Maximum difference voltage: CSOP–CSON, CSSP–CSSN		-0.3		0.3	V
Junction temperature		-40		125	°C
Storage temperature		-55		150	°C

### 7.4 Thermal Information

THERMAL METRIC <sup>(1)</sup>		bq24765		UNIT
		RUV (VQFN)		
		34 PINS		
R <sub>θJA</sub>	Junction-to-ambient thermal resistance	33.7		°C/W
R <sub>θJC(top)</sub>	Junction-to-case (top) thermal resistance	23		°C/W
R <sub>θJB</sub>	Junction-to-board thermal resistance	6.3		°C/W
Ψ <sub>JT</sub>	Junction-to-top characterization parameter	0.3		°C/W
Ψ <sub>JB</sub>	Junction-to-board characterization parameter	6.1		°C/W
R <sub>θJC(bot)</sub>	Junction-to-case (bottom) thermal resistance	1.9		°C/W

(1) For more information about traditional and new thermal metrics, see the *Semiconductor and IC Package Thermal Metrics* application report, [SPRA953](#).

## 7.5 Electrical Characteristics

7.0 V ≤ V(DCINA) ≤ 24 V, 0°C < T<sub>J</sub> < +125°C, typical values are at T<sub>A</sub> = 25°C, with respect to AGND (unless otherwise noted)

PARAMETER		TEST CONDITIONS	MIN	TYP	MAX	UNIT
<b>OPERATING CONDITIONS</b>						
V <sub>DCIN_OP</sub>	DCINA/DCINP input voltage operating range		7		24	V
<b>CHARGE VOLTAGE REGULATION</b>						
V <sub>VFB_OP</sub>	VFB input voltage range		0	DCINA		V
V <sub>VFB_REG_ACC</sub>	VFB charge voltage regulation accuracy	ChargeVoltage() = 0x41A0	16.716	16.8	16.884	V
			-0.5%		0.5%	
		ChargeVoltage() = 0x3130	12.529	12.592	12.655	V
			-0.5%		0.5%	
		ChargeVoltage() = 0x20D0	8.350	8.4	8.450	V
			-0.6%		0.6%	
V <sub>VFB_REG_RNG</sub>	Charge voltage regulation range		1.024		19.2	V
<b>CHARGE CURRENT REGULATION</b>						
V <sub>IREG_CHG_RNG</sub>	Charge current regulation differential voltage range	V <sub>IREG_CHG</sub> = V <sub>CSOP</sub> - V <sub>CSOIN</sub> , Maximum charge current is 8.064 A with 10-mΩ sense resistor.	0		8064	mV
I <sub>CHRG_REG_ACC</sub>	Charge current regulation accuracy	ChargeCurrent() = 0x0F80		3968		mA
			-3%		3%	
		ChargeCurrent() = 0x0800		2048		mA
			-5%		5%	
		ChargeCurrent() = 0x0200		512		mA
			-25%		25%	
		ChargeCurrent() = 0x0080		128		mA
			-33%		33%	
<b>INPUT CURRENT REGULATION</b>						
V <sub>IREG_DPM_RNG</sub>	Adapter current regulation differential voltage range	V <sub>IREG_DPM</sub> = V <sub>CSSP</sub> - V <sub>CSSN</sub>	0		110.08	mV
I <sub>INPUT_REG_ACC</sub>	Input current regulation accuracy	InputCurrent() ≥ 0x0800		4096		mA
			-3%		3%	
		InputCurrent() = 0x0400		2048		mA
			-5%		5%	
		InputCurrent() = 0x0100		512		mA
			-25%		25%	
InputCurrent() = 0x0080		256		mA		
	-33%		33%			
<b>THERMAL REGULATION</b>						
T <sub>J_REG_ACC</sub>	Junction temperature regulation accuracy	CE=High; Charging	110	120	130	°C
<b>VREF REGULATOR</b>						
V <sub>VREF_REG</sub>	VREF regulator voltage	V <sub>DCIN</sub> > V <sub>DCIN_UVLO</sub> ; V <sub>ACIN</sub> > 0.6 V	3.267	3.3	3.333	V
I <sub>VREF_LIM</sub>	VREF current limit	V <sub>VREF</sub> = 0 V, V <sub>DCIN_UVLO</sub> ; V <sub>ACIN</sub> > 0.6 V	35		75	mA
<b>VDDP REGULATOR</b>						
V <sub>VDDP_REG</sub>	VDDP regulator voltage	V <sub>DCIN</sub> > V <sub>DCIN_UVLO</sub> ; V <sub>ACIN</sub> > 2.4 V, CE=High	5.7	6.0	6.3	V
I <sub>VDDP_LIM</sub>	VDDP current limit	V <sub>VDDP</sub> = 0 V, V <sub>DCIN</sub> > V <sub>DCIN_UVLO</sub> ; V <sub>ACIN</sub> > 2.4 V, CE=High	90		135	mA
		V <sub>VDDP</sub> = 5 V, V <sub>DCIN</sub> > V <sub>DCIN_UVLO</sub> ; V <sub>ACIN</sub> > 2.4 V, CE=High	80			

**Electrical Characteristics (continued)**

 7.0 V ≤ V(DCINA) ≤ 24 V, 0°C < T<sub>J</sub> < +125°C, typical values are at T<sub>A</sub> = 25°C, with respect to AGND (unless otherwise noted)

PARAMETER		TEST CONDITIONS	MIN	TYP	MAX	UNIT
<b>ADAPTER CURRENT SENSE AMPLIFIER</b>						
V <sub>CSSP/N_OP</sub>	Input common mode	Voltage on CSSP/CSSN	0		24	V
V <sub>VICM</sub>	VICM output voltage		0		2	V
I <sub>VICM</sub>	VICM Output Current		0		1	mA
A <sub>VICM</sub>	Current sense amplifier voltage gain	A <sub>VICM</sub> = V <sub>VICM</sub> / V <sub>I<sub>REG_DPM</sub></sub>		20		V/V
	Adapter current sense accuracy	V <sub>I<sub>REG_DPM</sub></sub> = V(CSSP–CSSN) ≥ 40 mV	–2%		2%	
		V <sub>I<sub>REG_DPM</sub></sub> = V(CSSP–CSSN) = 20 mV	–3%		3%	
		V <sub>I<sub>REG_DPM</sub></sub> = V(CSSP–CSSN) = 5 mV	–25%		25%	
		V <sub>I<sub>REG_DPM</sub></sub> = V(CSSP–CSSN) = 1.5 mV	–33%		33%	
I <sub>VICM_LIM</sub>	Output current limit	V <sub>VICM</sub> = 0 V	1			mA
C <sub>VICM_MAX</sub>	Maximum output load capacitance	For stability with 0-mA to 1-mA load			100	pF
<b>ACIN COMPARATOR (Adapter Detect)</b>						
V <sub>DCIN_VFB_OP</sub>	Differential voltage from DCINA to VFB		–20		24	V
V <sub>ACIN_CHG</sub>	ACIN rising threshold	Min voltage to enable charging, V <sub>ACIN</sub> rising	2.376	2.40	2.424	V
V <sub>ACIN_CHG_HYS</sub>	ACIN falling hysteresis	V <sub>ACIN</sub> falling		40		mV
	ACIN rising deglitch <sup>(1)</sup>	V <sub>ACIN</sub> rising		100		μs
V <sub>ACIN_BIAS</sub>	Adapter present rising threshold	Min voltage to enable all bias, V <sub>ACIN</sub> rising	0.56	0.62	0.68	V
V <sub>ACIN_BIAS_HYS</sub>	Adapter present falling hysteresis	V <sub>ACIN</sub> falling		20		mV
<b>V(DCIN–VFB) COMPARATOR (Reverse Discharging Protection)</b>						
V <sub>DCIN-VFB_FALL</sub>	DCIN to VFB falling threshold	V <sub>DCIN</sub> – V <sub>VFB</sub> falling	140	185	240	mV
V <sub>DCIN-VFB_HYS</sub>	DCIN to VFB hysteresis			50		mV
	DCIN to VFB rising deglitch	V <sub>DCIN</sub> – V <sub>VFB</sub> > V <sub>DCIN-VFB_RISE</sub>		1		ms
<b>VFB OVERVOLTAGE COMPARATOR</b>						
V <sub>OV_RISE</sub>	Over-voltage rising threshold	As percentage of V <sub>VFB_REG</sub>		104%		
V <sub>OV_FALL</sub>	Over-voltage falling threshold	As percentage of V <sub>VFB_REG</sub>		102%		
<b>VFB BATSHORT COMPARATOR (Undervoltage)</b>						
V <sub>VFB_SHORT_RISE</sub>	VFB short rising threshold		2.6	2.7	2.85	V
V <sub>VFB_SHORT_HYS</sub>	VFB short falling hysteresis			250		mV
V <sub>VFB_SHORT_ICHG</sub>	VFB short precharge current		60	220		mA
<b>VFB BATLOWV COMPARATOR</b>						
V <sub>VFB_LOWV_RISE</sub>	VFB LOWV rising threshold		3.9	4	4.1	V
V <sub>VFB_LOWV_HYS</sub>	VFB LOWV falling hysteresis			400		mV
	VFB LOWV one-shot reset time	Time to time charger		2		ms
V <sub>VFB_LOWV_ICHG</sub>	VFB LOWV max DAC output	VFB falling, on 10-mΩ resistor			3	A
<b>CHARGE OVER-CURRENT COMPARATOR – Average current using sense resistor</b>						
	Charge overcurrent falling threshold	V(CSOP–CSON) > 33 mV, as percentage of I <sub>REG_CHG</sub>		145%		
	Minimum current limit	V(CSOP–CSON) < 33 mV		50		mV
	Internal filter pole frequency			160		kHz
<b>CHARGE OVER-CURRENT COMPARATOR – Cycle-by-Cycle Maximum current using High-Side SenseFet</b>						
V <sub>OCP_CycleByCycle</sub>	Charge over-current rising threshold, latches off high-side MOSFET until next cycle.	High-side drain current rising-edge.	8	10	12	A

(1) Verified by design.

## Electrical Characteristics (continued)

7.0 V ≤ V(DCINA) ≤ 24 V, 0°C < T<sub>J</sub> < +125°C, typical values are at T<sub>A</sub> = 25°C, with respect to AGND (unless otherwise noted)

PARAMETER		TEST CONDITIONS	MIN	TYP	MAX	UNIT
<b>DCIN INPUT UNDERVOLTAGE LOCK-OUT COMPARATOR (UVLO)</b>						
V <sub>DCIN_UVLO</sub>	DCINA undervoltage rising threshold	Measure on DCINA pin	3.5	4	4.5	V
V <sub>DCIN_UVLO_HYS</sub>	DCINA undervoltage hysteresis, falling			260		mV
<b>INPUT CURRENT COMPARATOR</b>						
V <sub>ICOMP_OFFSET</sub>	AC low power mode comparator offset voltage	On ICREF	-8		8	mV
<b>THERMAL SHUTDOWN COMPARATOR</b>						
T <sub>SHUT</sub>	Thermal shutdown threshold with rising temperature	Temperature rising		155		°C
T <sub>SHUT_HYS</sub>	Thermal shutdown hysteresis, falling	Temperature falling		20		
<b>PWM HIGH SIDE POWER MOSFET</b>						
R <sub>DSON_HI</sub>	High side power MOSFET drain to source on resistance	V <sub>BOOT</sub> – V <sub>PHASE</sub> = 5.5 V, Drain current = 4 A, T <sub>J</sub> = 25°C		27	32	mΩ
		V <sub>BOOT</sub> – V <sub>PHASE</sub> = 5.5 V, Drain current = 4 A, T <sub>J</sub> = 0 to 125°C		27	46	
V <sub>BOOT_REFRESH</sub>	Bootstrap refresh comparator threshold voltage	V <sub>BOOT</sub> – V <sub>PHASE</sub> when low side refresh pulse is requested	4			V
I <sub>BOOT_LEAK</sub>	BOOT leakage current	High Side is on; Charge enabled			200	μA
<b>PWM LOW SIDE POWER MOSFET</b>						
R <sub>DS_LO_ON</sub>	Low side power MOSFET drain to source on resistance	V <sub>VDDP</sub> = 6 V, Drain Current = 4 A, T <sub>J</sub> = 25°C		38	45	mΩ
		V <sub>VDDP</sub> = 6 V, Drain Current = 4 A, T <sub>J</sub> = 0 to 125°C		38	66	
<b>PWM DRIVERS TIMING</b>						
	Minimum driver dead time	Dead time when switching between High-Side MOSFET and Low-Side MOSFET. Adaptive protective dead-time could be more.		25		ns
<b>PWM OSCILLATOR</b>						
F <sub>SW</sub>	PWM switching frequency		540	700	840	kHz
V <sub>RAMP_OFFSET</sub>	PWM ramp offset			200		mV
V <sub>RAMP_HEIGHT</sub>	PWM ramp height	As percentage of DCINA		6.67		%DCINA
<b>QUIESCENT CURRENT</b>						
I <sub>OFF_STATE</sub>	Total off-state battery current from CSOP, CSON, VFB, DCINA, DCINP, BOOT, PHASE, etc., Adapter removed	V <sub>VFB</sub> = 16.8 V, V <sub>ACIN</sub> < 0.6 V, V <sub>DCINA</sub> > 5 V, ≤ T <sub>J</sub> = 0°C to 85°C		7	10	μA
I <sub>BAT_ON</sub>	Battery on-state quiescent current	V <sub>VFB</sub> = 16.8 V, 0.6 V < V <sub>ACIN</sub> < 2.4 V, V <sub>DCINA</sub> > 5 V		1		mA
I <sub>BAT_LOAD_CD</sub>	Internal battery load current, during charge disabled, adapter connected	Charge is disabled: V <sub>VFB</sub> = 16.8 V, V <sub>ACIN</sub> > 2.4 V, V <sub>DCINA</sub> > 5 V		0.5	1	mA
I <sub>BAT_LOAD_CE</sub>	Internal battery load current during charge enabled, charging. CSOP, CSON, VFB, BOOT, PHASE	CE = high, V <sub>VFB</sub> = 16.8 V, V <sub>ACIN</sub> > 2.4 V, V <sub>DCINA</sub> > 5 V	6	10	12	mA
I <sub>AC</sub>	Adapter quiescent current, charge disabled	CE = low, V <sub>DCINA</sub> = 20 V		0.5	1	mA
I <sub>AC_SWITCH</sub>	Adapter switching quiescent current	Charge enabled, V <sub>DCINA</sub> = 20 V, converter switching		25		mA
<b>INTERNAL SOFT START (8 Steps to Regulation Current ICHG)</b>						
	Soft start steps			8		step
	Soft start step time			1.6		ms
<b>CHARGER SECTION POWER-UP SEQUENCING</b>						
	Charge-Enable Delay after Power-up	Delay from when adapter is detected and CE is high to when the charger is allowed to turn on		2		ms

## Electrical Characteristics (continued)

7.0 V ≤ V(DCINA) ≤ 24 V, 0°C < T<sub>J</sub> < +125°C, typical values are at T<sub>A</sub> = 25°C, with respect to AGND (unless otherwise noted)

PARAMETER		TEST CONDITIONS	MIN	TYP	MAX	UNIT
<b>CHARGE UNDERCURRENT COMPARATOR (Cycle-by-Cycle Synchronous to Non-Synchronous)</b>						
V <sub>UCP</sub>	Cycle-by-cycle Synchronous to Non-Synchronous Transition Threshold	Cycle-by-cycle, (CSOP-CSON) voltage, falling, LGATE turns-off and latches off until next cycle	5	10	15	mV
<b>LOGIC INPUT PIN CHARACTERISTICS (CE, SDA, SCL)</b>						
V <sub>IN_LO</sub>	Input low threshold voltage				0.8	V
V <sub>IN_HI</sub>	Input high threshold voltage	Pull-up CE with ≥ 2 kΩ resistor, or connect directly to VREF.	2.1			V
V <sub>BIAS</sub>	Input bias current	V = 0 to 7 V			1	μA
<b>OPEN-DRAIN LOGIC OUTPUT PIN CHARACTERISTICS (ACOK, ICOUT)</b>						
V <sub>OUT_LO</sub>	Output low saturation voltage	Sink Current = 5 mA			0.5	V
<b>VDDSMB INPUT SUPPLY FOR SMBUS</b>						
V <sub>VDDSMB_RANGE</sub>	VDDSMB input voltage range		2.7		5.5	V
V <sub>VDDSMB_UVLO_Threshold_Rising</sub>	VDDSMB undervoltage lockout threshold voltage, rising	V <sub>VDDSMB</sub> Rising	2.4	2.5	2.6	V
V <sub>VDDSMB_UVLO_Hyst_Rising</sub>	VDDSMB undervoltage lockout hysteresis voltage, falling	V <sub>VDDSMB</sub> Falling	100	150	200	mV
I <sub>VDDSMB_Iq</sub>	VDDSMB quiescent current	V <sub>VDDSMB</sub> = SCL = SDA = 3.3 V		20	30	μA

## 7.6 SMB Timing Requirements

PARAMETER		TEST CONDITIONS	MIN	TYP	MAX	UNIT
t <sub>R</sub>	SCLK/SDATA rise time				1	μs
t <sub>F</sub>	SCLK/SDATA fall time				300	ns
t <sub>W(H)</sub>	SCLK pulse width high		4		50	μs
t <sub>W(L)</sub>	SCLK Pulse Width Low		4.7			μs
t <sub>SU(STA)</sub>	Setup time for START condition		4.7			μs
t <sub>H(STA)</sub>	START condition hold time after which first clock pulse is generated		4			μs
t <sub>SU(DAT)</sub>	Data setup time		250			ns
t <sub>H(DAT)</sub>	Data hold time		300			ns
t <sub>SU(STOP)</sub>	Setup time for STOP condition		4			μs
t <sub>(BUF)</sub>	Bus free time between START and STOP condition		4.7			μs
F <sub>S(CL)</sub>	Clock Frequency		10		100	kHz
<b>HOST COMMUNICATION FAILURE</b>						
t <sub>timeout</sub>	SMBus bus release timeout		22	25	35	ms
t <sub>BOOT</sub>	Deglintch for watchdog reset signal		10			ms
t <sub>WDI</sub>	Watchdog timeout period		140	170	200	s
<b>OUTPUT BUFFER CHARACTERISTICS</b>						
V <sub>(SDAL)</sub>	Output LO voltage at SDA, I <sub>(SDA)</sub> = 3 mA				0.4	V

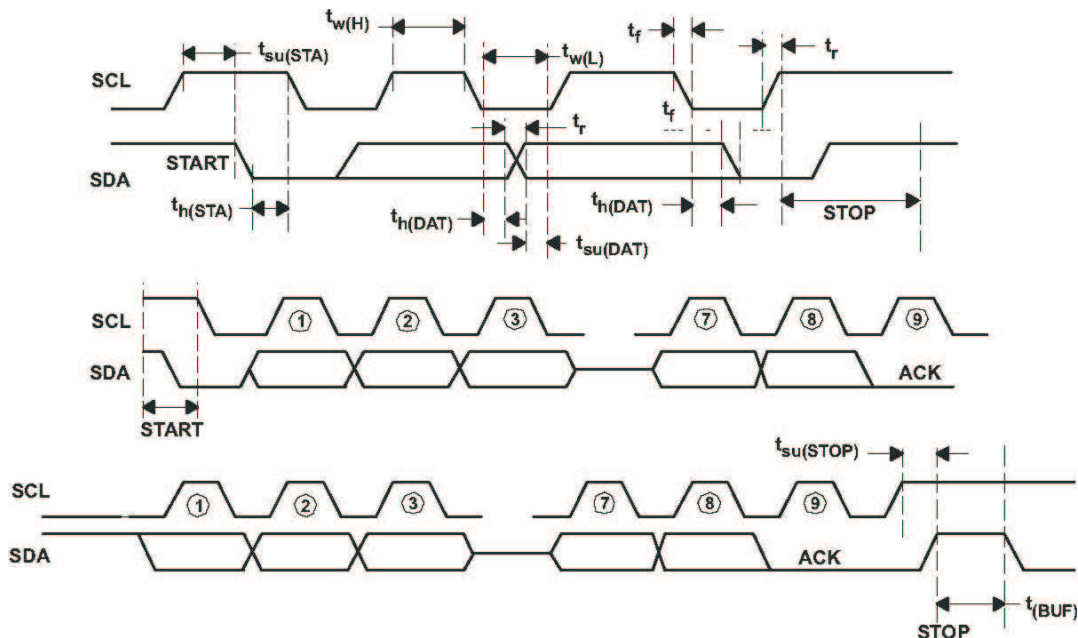

**Figure 1. SMBus Communication Timing Waveforms**

## 7.7 Typical Characteristics

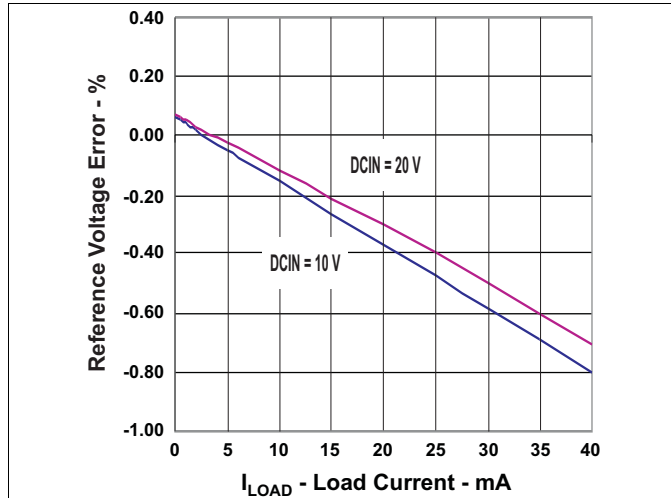

Figure 2. VREF Load and Line Regulation vs Load Current

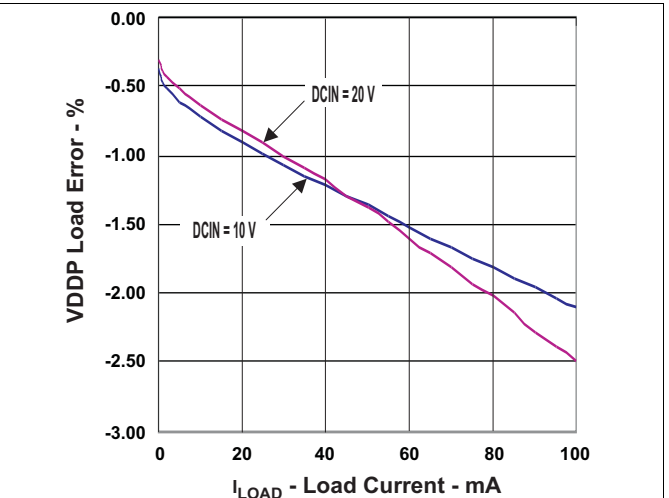

Figure 3. VDDP Load and Line Regulation vs Load Current

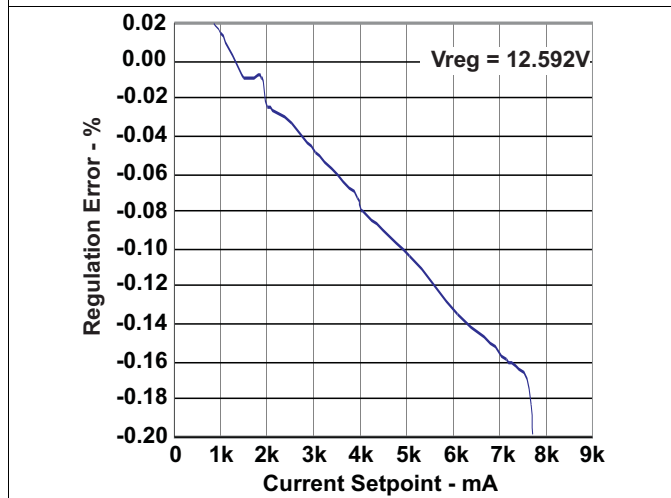

Figure 4. VFB Voltage Regulation Accuracy vs Charge Current

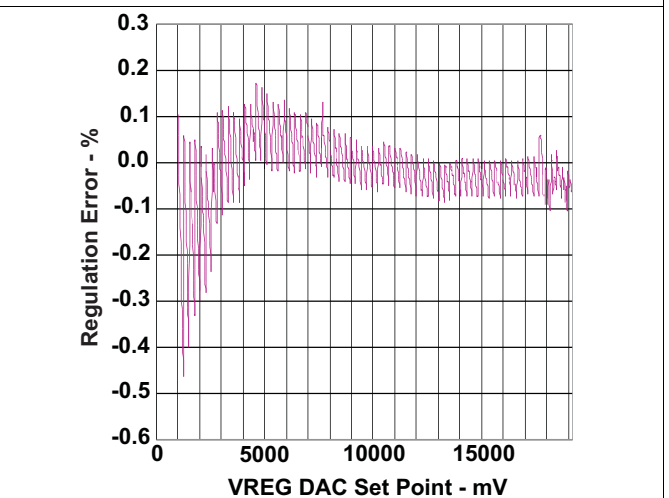

Figure 5. VFB Voltage Regulation Accuracy vs Set Point

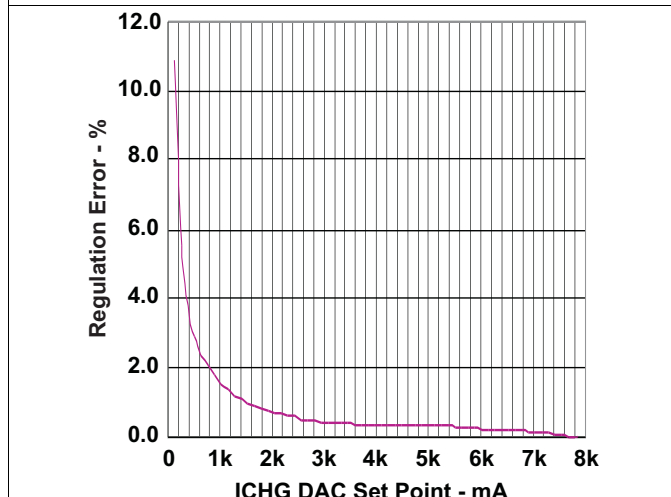

Figure 6. Charge Current Regulation Accuracy vs V(CSOP-CSON) Voltage Set Point

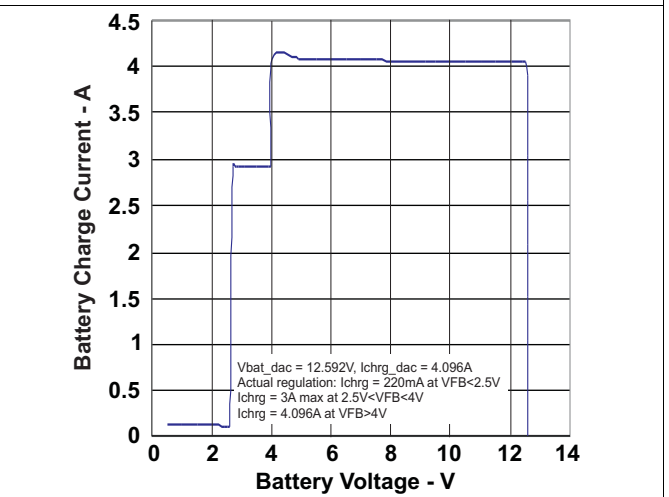

Figure 7. Charge Current Regulation vs VFB Voltage

Typical Characteristics (continued)

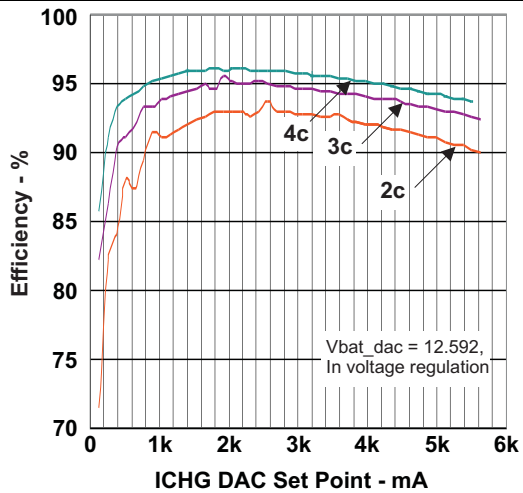

Figure 8. Efficiency vs Battery Charge Current

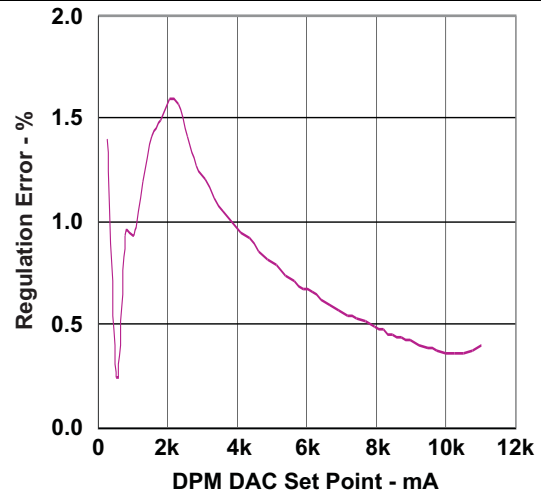

Figure 9. Input Current Regulation (DPM) Accuracy vs V(CSSP-CSSN) Voltage Set Point

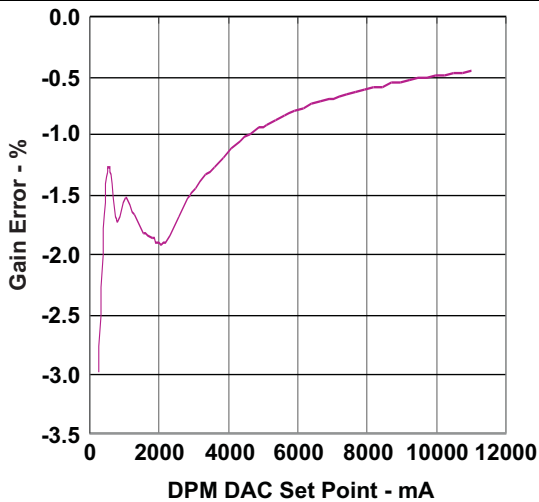

Figure 10. VICM Input Current Sense Amplifier Accuracy vs V(CSSP-CSSN) Voltage

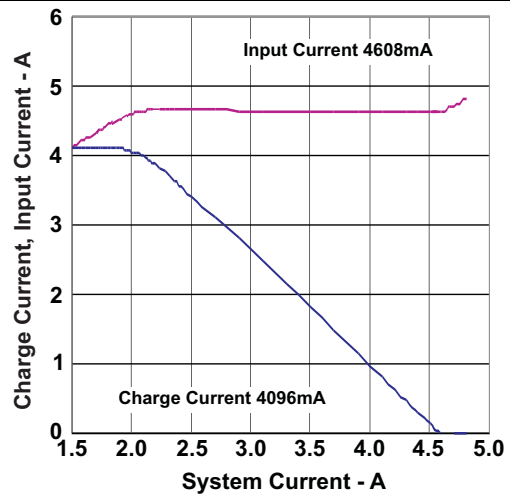

Figure 11. Input Regulation Current (DPM) and Charge Current vs System Current

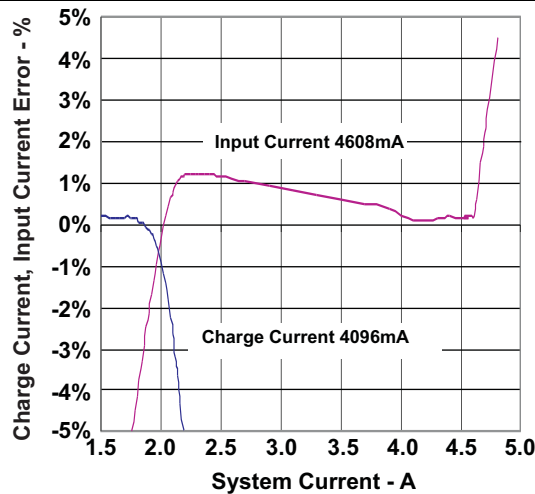

Figure 12. Input Regulation Current (DPM), and Charge Current Accuracy vs System Current

## 8 Detailed Description

### 8.1 Overview

The bq24765 integrates buck switching FETs with 700kHz operation for space-constrained, multi-chemistry portable applications such as notebook and detachable ultrabook. It supports wide input range of input sources from 7 V to 24 V, and 1~19.2-V charge voltage setting.

The bq24765 features Dynamic Power Management (DPM) to limit the input power and avoid AC adapter overloading. During battery charging, as the system power increases, the charging current will reduce to maintain total input current below adapter rating.

The SMBus controls input current, charge current and charge voltage registers with high resolution, high accuracy regulation limits.

## 8.2 Functional Block Diagram

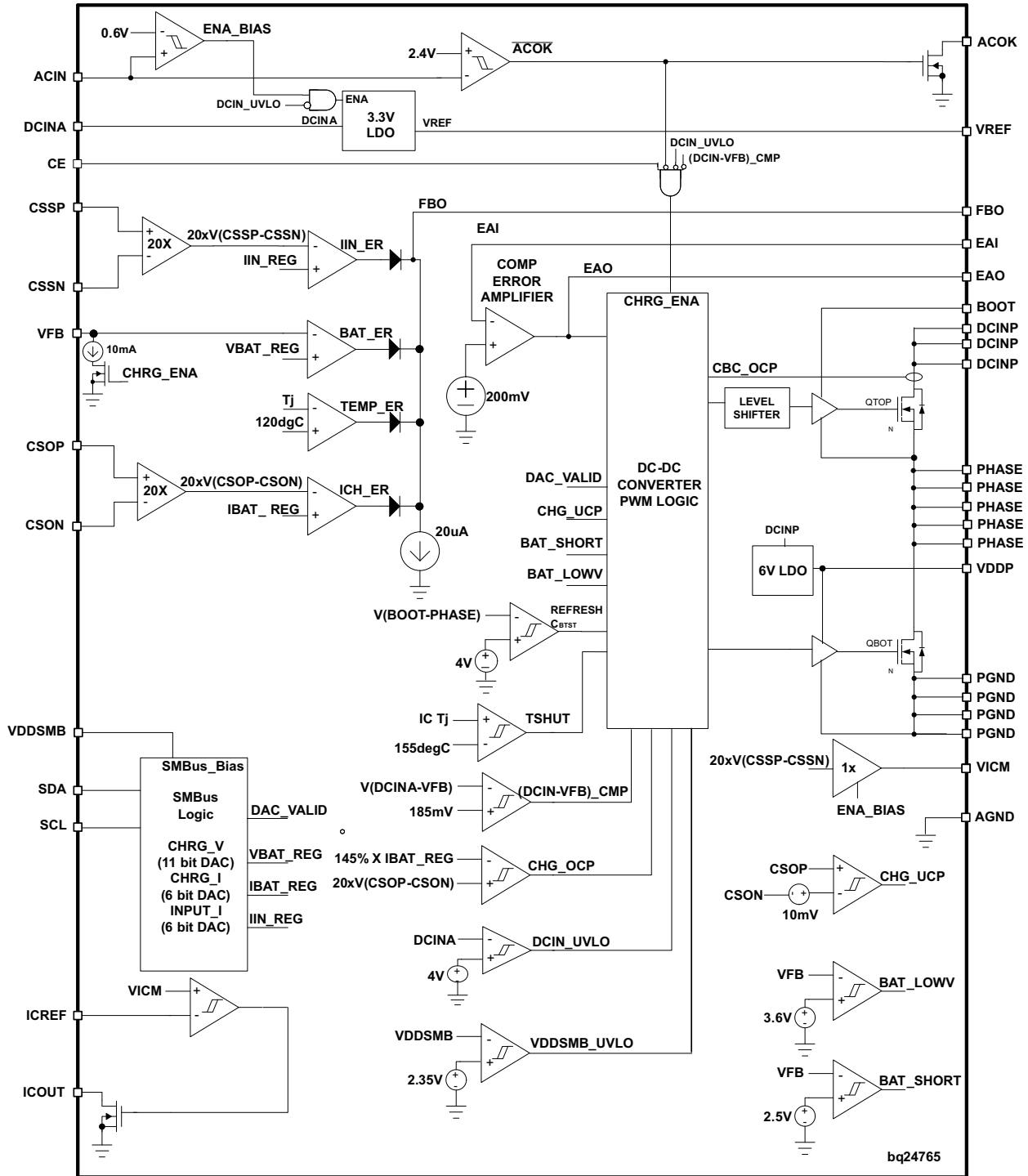

## 8.3 Feature Description

### 8.3.1 Adapter Detect and Power Up

An external resistor voltage divider attenuates the adapter voltage before it goes to ACIN. The adapter detect threshold should typically be programmed to a value greater than the maximum battery voltage and lower than the minimum allowed adapter voltage. The ACIN divider should be placed before the input power path selector in order to sense the true adapter input voltage.

If DCINA is below 4 V, the device is disabled.

If ACIN is below 0.6 V but DCINA is above 4.5 V, ACOK and VICM are disabled and pulled down to GND. The total quiescent current is less than 10  $\mu$ A.

Once ACIN rises above 0.6 V and DCINA is above 4.5 V, VREF goes to 3.3 V and all the bias circuits are enabled, ACOK low indicated ACIN is still below 2.4 V and the valid adaptor is not available. VICM becomes valid to proportionally reflect the adapter current.

When ACIN keeps rising and passes 2.4 V, a valid AC adapter is present. 100  $\mu$ s later, the following occurs:

- ACOK becomes high through external pull-up resistor to the VREF rail
- Charger turns on if all the conditions are satisfied (refer to )

### 8.3.2 Enable and Disable Charging

The following conditions must be valid before charging is enabled:

- Not in UVLO (DCINA > 4.5 V, and VDDSMB > 2.5 V)
- Adapter is detected (ACIN > 2.4 V)
- Adapter – Battery voltage is higher than V(DCINA-VFB) Comparator threshold
- SMBus ChargeVoltage(), ChargeCurrent(), and InputCurrent() DAC registers are inside the valid range
- CE is HIGH
- 2 ms delay is complete after adapter detected and CE goes high
- VDDP and VREF are valid
- Not in Thermal Shutdown (TSHUT)

One of the following conditions will stop the on-going charging:

- SMBus ChargeVoltage(), ChargeCurrent(), or InputCurrent() DAC registers are outside the valid range
- CE is LOW
- Adapter is removed; (DCINA < 4 V)
- VDDSMB supply is removed. (VDDSMB < 2.35 V)
- Adapter – Battery voltage is less than V(DCINA-VFB) Comparator threshold
- Battery is over voltage
- In Thermal Shutdown: TSHUT IC temperature threshold is above 155°C

### 8.3.3 Automatic Internal Soft-Start Charger Current

The charger automatically soft-starts the output regulation current every time the charger is enabled to ensure there is no overshoot or stress on the output capacitors or the power converter. The soft-start consists of stepping-up the charge regulation current into 8 evenly divided steps up to the programmed charge current. Each step lasts around 1.6 ms, for a typical rise time of 10ms. No external components are needed for this function. The regulation limits can be changed in the middle of charging without soft start.

### 8.3.4 Switching Frequency

The bq24765 switching frequency is 700 kHz. A high switching frequency allows a smaller inductor to give the same ripple current, or can be used to reduce the ripple current for the same inductor. A smaller inductor value may allow using a smaller inductor physical size, for a smaller board footprint area.

**Table 1. Output LC Filter Component Selection Table**

bq24765 (Fs = 700 kHz)				
Vin	Vout	Iout	Lout	Cout
19.5 V	3s/4s 12.6 V/16.8 V	1.5 A	4.7 µH	10 µF
		3 A	4.7 µH	10 µF, 20 µF
		4.5 A	3.3 µH	20 µF
		6 A	3.3 µH	20 µF, 30 µF
12 V	2 s 8.4 V	1.5 A	5.6 µH	10 µF
		3 A	4.7 µH	10 µF, 20 µF
		4.5 A	3.3 µH	20 µF
		6 A	2.2 µH	20 µF, 30 µF

- Shaded areas are the most likely applications.
- External compensation can be recalculated if need other values.
- Lower current applications can use the inductance used at higher currents, but would operate in DCM more often.

### 8.3.5 Converter Operation

The synchronous buck PWM converter uses a fixed frequency (700 kHz) voltage mode with feed-forward control scheme. A type III compensation network allows using ceramic capacitors at the output of the converter. The compensation input stage is connected between the feedback output (FBO) and the error amplifier input (EAI). The feedback compensation stage is connected between the error amplifier input (EAI) and error amplifier output (EAO). The LC output filter selected gives a characteristic resonant frequency that is used to determine the compensation to ensure there is sufficient phase margin for the target bandwidth.

$$f_o = \frac{1}{2\pi\sqrt{L_o C_o}}$$

The resonant frequency,  $f_o$ , is given by:

An internal saw-tooth ramp is compared to the internal EAO error control signal to vary the duty-cycle of the converter. The ramp height is one-fifteenth of the input adapter voltage making it always directly proportional to the input adapter voltage. This cancels out any loop gain variation due to a change in input voltage, and simplifies the loop compensation. The ramp is offset by 200 mV in order to allow zero percent duty-cycle, when the EAO signal is below the ramp. The EAO signal is also allowed to exceed the saw-tooth ramp signal in order to get a 100% duty-cycle PWM request. Internal gate drive logic allows achieving 99.98% duty-cycle while ensuring the N-channel upper device always has enough voltage to stay fully on. If the BOOT pin to PHASE pin voltage falls below 4 V for more than 3 cycles, then the high-side n-channel power MOSFET is turned off and the low-side n-channel power MOSFET is turned on to pull the PHASE node down and recharge the BOOT capacitor. Then the high-side driver returns to 100% duty-cycle operation until the (BOOT-PHASE) voltage is detected to fall low again due to leakage current discharging the BOOT capacitor below the 4 V, and the recharge pulse is reissued.

The fixed frequency oscillator keeps tight control of the switching frequency under all conditions of input voltage, battery voltage, charge current, and temperature, simplifying output filter design and keeping it out of the audible noise region. The type III compensation provides phase boost near the cross-over frequency, giving sufficient phase margin.

### 8.3.6 Refresh BTST Capacitor

If the BOOT pin to PHASE pin voltage falls below 4 V for more than 3 cycles, then the high-side n-channel power MOSFET is turned off and the low-side n-channel power MOSFET is turned on for 40ns to pull the PHASE node down and recharge the BOOT capacitor. The 40ns low-side MOSFET on-time is required protect from ringing noise, and to ensure the bootstrap capacitor is always recharged and able to keep the high-side power MOSFET on during the next cycle.

### 8.3.7 UCP (Charge Undercurrent): Using Sense Resistor

In bq24765, the cycle-by-cycle UCP allows using very small inductors seamlessly, even if they have large ripple current. Every cycle when the low-side MOSFET turns-on, if the CSOP-CSON voltage falls below 10 mV (inductor current falls below 1 A if using 10-mΩ sense resistor), the low-side MOSFET is latched off until the next cycle begins and resets the latch.

The converter automatically detects when to turn-off the low-side MOSFET every cycle. The inductor current ripple is given by

$$I_{DCM} < \frac{I_{RIPPLE}}{2}$$

$$\text{and } I_{RIPPLE} = \frac{(V_{IN} - V_{BAT}) \times \left(\frac{V_{BAT}}{V_{IN}}\right) \times \left(\frac{1}{f_S}\right)}{L_{out}}$$

where

- $V_{IN}$ : adapter voltage
- $V_{VFB}$ : Output Voltage = VFB voltage
- $f_S$ : switching frequency = 700 kHz
- $L_{OUT}$ : output inductor

(1)

For proper cycle-by-cycle UCP sensing, the output filter capacitor should sit on CSON. Only 0.1μF capacitor is on CSOP, close to the device input.

### 8.3.8 Cycle-By-Cycle Charge Overcurrent Protection, Using High-Side Sense-FET

The charger has a cycle-to-cycle over-current protection to protect from exceeding the maximum current capability of the integrated power MOSFETs. It monitors the drain current of the high-side power MOSFET using a sense-FET, and prevents the current from exceeding 10 A peak. The integrated high-side power MOSFET turns off when the over-current is detected, and latches off until the following cycle.

### 8.3.9 Average Charge Overcurrent Protection, Using Sense Resistor

The charger has an average over-current protection using the V(CSON-CSOP) voltage across the charge current sense resistor. It monitors the charge current, and prevents the current from exceeding 145% of programmed regulated charge current. If the charge current limit falls below 3.3 A (on 10 mΩ), the over current limit is fixed at 5 A. The high-side gate drive turns off when the over-current is detected, and automatically resumes when the current falls below the over-current threshold. There is an internal 160-kHz filter pole, to filter the switching frequency and prevent false tripping. This will add a small delay depending on the amount of overdrive over the threshold.

### 8.3.10 Battery Overvoltage Protection, Using Remote Sensing VFB

The converter will not allow switching when the battery voltage at VFB exceeds 104% of the regulation voltage set-point. Once the VFB voltage returns below 102% of the regulation voltage, switching resumes. This allows quick response to an over-voltage condition – such as occurs when the load is removed or the battery is disconnected. A 10-mA current sink from CSOP and CSON to AGND is on only during charging and allows discharging the stored output inductor energy that is transferred to the output capacitors.

### 8.3.11 Battery Short Protection

The bq24765 has a BAT LOWV comparator monitoring the output battery VFB voltage. If the voltage falls below 3.6 V, the battery short status is detected. Once the short status is detected, charger immediately stops for 2 ms to avoid inductor peak current surge. After 2 ms, the charger will soft-start again. If the battery voltage is still below 2.5 V, a 220-mA trickle charge current is applied. Otherwise, the charge current limit is set by ChargeCurrent(). Refer to [Electrical Characteristics](#).

### 8.3.12 Battery Trickle Charging

The bq24765 automatically reduces the charge current limit to a fixed 220 mA to trickle charge the battery, when the voltage on the VFB pin falls below 2.5 V. The charge current returns to the value programmed on the ChargeCurrent(0x14) register, when the VFB pin voltage rises above 2.7 V. This function provides a safe trickle charge to close deeply discharged open packs.

### 8.3.13 High Accuracy VICM Using Current Sense Amplifier (CSA)

An industry standard, high accuracy current sense amplifier (CSA) is used to monitor the input current by the host or some discrete logic through the analog voltage output of the VICM pin. The CSA amplifies the input sensed voltage of C<sub>SSP</sub>-C<sub>SSN</sub> by 20x through the VICM pin. Once DCIN is above 4.5 V and ACIN is above 0.6 V, VICM no longer stays at ground, but becomes active. If the user wants to lower the voltage, they could use a resistor divider from VICM to AGND, and still achieve accuracy over temperature as the resistors can be matched their thermal coefficients.

A 100pF capacitor connected on the output is recommended for decoupling high-frequency noise.

### 8.3.14 VDDSMB Input Supply

The VDDSMB input provides bias power to the SMBus interface logic. Connect VDDSMB to an external 3.3-V or 5-V supply rail. SMBus communication can occur between host and charger when VDDSMB voltage above 2.5 V and VREF voltage at 3.3 V. Bypass VDDSMB to AGND with a 0.1- $\mu$ F or greater ceramic capacitor.

### 8.3.15 Input Undervoltage Lockout (UVLO)

The system must have a minimum 4.5 V DCINA voltage to allow proper operation. When the DCINA voltage is below 4 V, VREF LDO stays inactive, even with ACIN above 0.6 V. VREF turns-on When DCINA > 4.5 V and ACIN > 0.6 V. To enable VDDP requires DCINA > 4.5 V, ACIN > 2.4 V and CE = HIGH.

### 8.3.16 VDDP Gate Drive Regulator

An integrated low-dropout (LDO) linear regulator provides a 6 V supply derived from DCINP, for high efficiency, and delivers over 90 mA of load current. The LDO powers the gate drivers of the n-channel switching MOSFETs. Bypass VDDP to PGND with a 1- $\mu$ F or greater ceramic capacitor. During thermal shut down, VDDP LDO is disabled.

### 8.3.17 Input Current Comparator Trip Detection

In order to optimize the system performance, the host keeps an eye on the adapter current. Once the adapter current is above a threshold set via ICREF, the ICOUT pin sends signal to the HOST. The signal alarms the host that input power has exceeded the programmed limit, allowing the host to throttle back system power by reducing clock frequency, lowering rail voltages, or disabling certain parts of the system. The ICOUT pin is an open-drain output. Connect a pull-up resistor to ICOUT. The output is logic HI when the VICM output voltage (VICM = 20 x V(C<sub>SSP</sub>-C<sub>SSN</sub>)) is lower than the ICREF input voltage. The ICREF threshold is set by an external resistor divider using VREF. A hysteresis can be programmed by a positive feedback resistor from ICOUT pin to the ICREF pin.

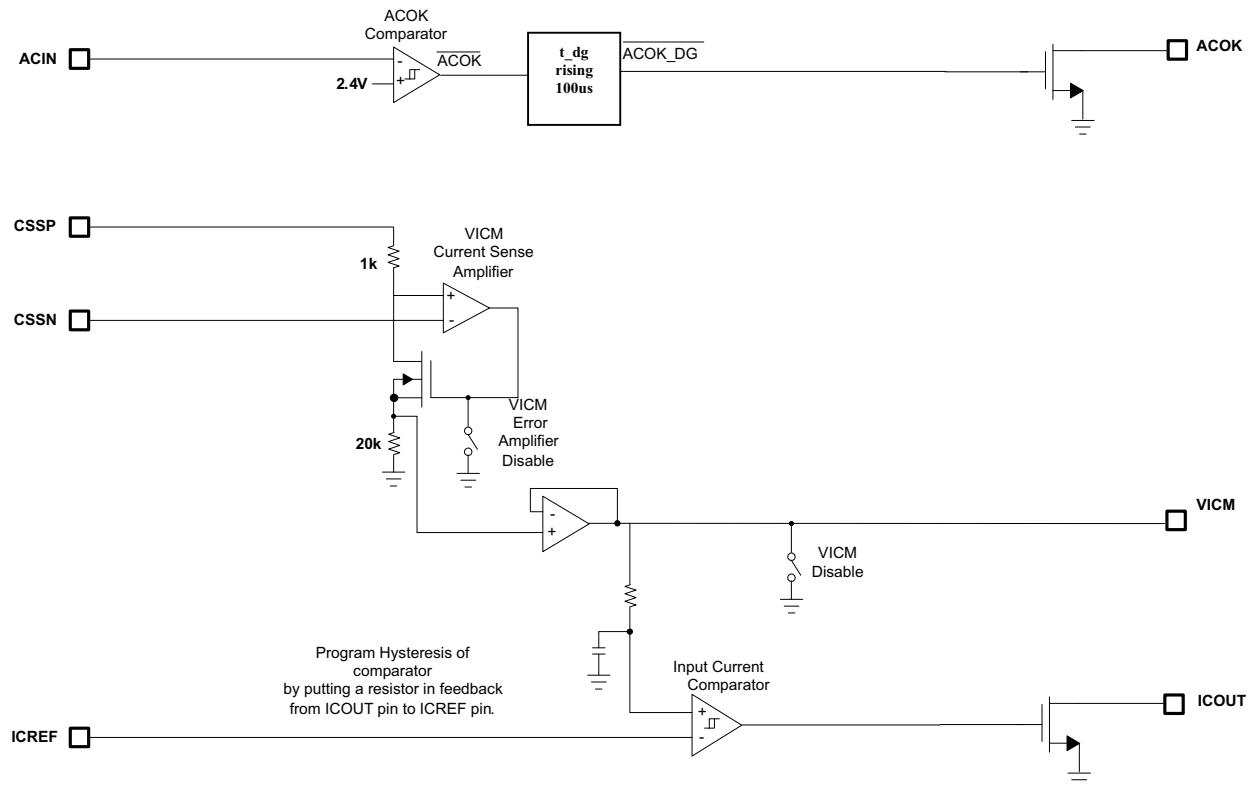
**Figure 13. ACOK, ICREF, and ICOUT Logic**

### 8.3.18 Open-Drain Status Outputs (ACOK, ICOUT Pins)

Two status outputs are available, and they both require external pull up resistors to pull the pins to system digital rail for a high level. ACOK open-drain output goes high when ACIN is above 2.4 V. It indicates a good adapter is connected because of valid input voltage. ICOUT open-drain output goes low when the input current is higher than the programmed threshold via ICREF pin. Hysteresis can be programmed by putting a resistor from ICREF pin to ICOUT pin.

### 8.3.19 Thermal Shutdown Protection

The QFN package has low thermal impedance, which provides good thermal conduction from the silicon to the ambient, to keep junctions temperatures low. As added level of protection, the charger converter turns off and self-protects whenever the junction temperature exceeds the TSHUT threshold of 155°C. VDDP LDO is disabled as well during thermal shut down. The charger stays off until the junction temperature falls below 135°C. Once the temperature drops below 135°C, VDDP LDO is enabled. If all the conditions described in “Enable and Disable Charging” section are valid, charge will soft start again.

### 8.3.20 Charger Timeout

The bq24765 includes a timer to terminate charging if the charger does not receive a ChargeVoltage() or ChargeCurrent() command within 170s. If a timeout occurs, both ChargeVoltage() and ChargeCurrent() commands must be resent to re-enable charging.

### 8.3.21 Charge Termination For Li-Ion or Li-Polymer

The primary termination method for Li-Ion and Li-Polymer is minimum current. Secondary temperature termination (see [Electrical Characteristics](#)) also provides additional safety. The host controls the charge initiation and the termination. A battery pack gas gauge assists the hosts on setting the voltages and determining when to terminate based on the battery pack state of charge.

### 8.3.22 Remote Sense

The bq24765 has a dedicated remote sense pin, VFB, which allows the rejection of board resistance and selector resistance. To fully utilize remote sensing, connect VFB directly to the battery interface through an unshared battery sense Kelvin trace, and place a 0.1- $\mu$ F ceramic capacitor near the VFB pin to AGND.

Remote Kelvin Sensing provides higher regulation accuracy, by eliminating parasitic voltage drops. Remote sensing cancels the effect of impedance in series with the battery. This impedance normally causes the battery charger to prematurely enter constant-voltage mode with reducing charge current.

## 8.4 Device Functional Modes

### 8.4.1 Continuous Conduction Mode and Discontinuous Conduction Mode

In Continuous Conduction Mode (CCM), the inductor current always flows to charge battery, and the charger always operates in synchronized mode. At the beginning of each clock cycle, high-side n-channel power MOSFET turns on, and the turn-on time is set by the voltage on the EAO pin. After the high-side power MOSFET turns off, the low-side n-channel power MOSFET turns on. During CCM, the low-side n-channel power MOSFET stays on until the end of the clock cycle. The internal gate drive logic ensures there is break-before-make switching to prevent shoot-through currents. During the 25 ns dead time where both FETs are off, the back-diode of the low-side power MOSFET conducts the inductor current. Having the low-side FET turn-on keeps the power dissipation low, and allows safely charging at high currents. With type III compensation, the loop has a fixed 2-pole system.

As the ripple valley current gets close to zero, charger operation goes to non-synchronized mode. During non-synchronous operation, after the high-side n-channel power MOSFET turns off, and after the break-before-make dead-time, the low-side n-channel power MOSFET will turn-on 40 ns. After the 40 ns blank out time is over, if V(CSOP-CSON) voltage falls below UCP threshold (typical 10 mV), the low-side power MOSFET will turn-off and stay off until the beginning of the next cycle, where the high-side power MOSFET is turned on again. After the low-side MOSFET turns off, the inductor current flows through back-gate diode until it reaches zero. The negative inductor current is blocked by the diode, and the inductor current will become discontinuous. This mode is called Discontinuous Conduction Mode (DCM).

During the DCM mode the loop response automatically changes and has a single pole system at which the pole is proportional to the load current, because the converter does not sink current, and only the load provides a current sink. This means at very low currents the loop response is slower, as there is less sinking current available to discharge the output voltage. At very low currents during non-synchronous operation, there may be a small amount of negative inductor current during the 40 ns recharge pulse. The charge should be low enough to be absorbed by the input capacitance.

Whenever the converter goes into zero percent duty-cycle, the high-side MOSFET does not turn on, and the low-side MOSFET does not turn on (no 40 ns recharge pulse) either, and there is no discharge from the battery; unless the BOOT to PHASE voltage discharges below 4 V. In that case, it pulses once to recharge the boot-strap capacitor.

## 8.5 Programming

### 8.5.1 Battery-Charger Commands

The bq24765 supports five battery-charger commands that use either Write-Word or Read-Word protocols, as summarized in [Table 2](#). ManufacturerID() and DeviceID() can be used to identify the bq24765. On the bq24765, the ManufacturerID() command always returns 0x0040 and the DeviceID() command always returns 0x0006.

**Table 2. Battery Charger SMBus Registers**

REGISTER ADDRESS	REGISTER NAME	READ/WRITE	DESCRIPTION	POR STATE	POR VOLTAGE/CURRENT
0x14	ChargeCurrent()	Read or Write	6-Bit Charge Current Setting	0x0000	0mA
0x15	ChargeVoltage()	Read or Write	11-Bit Charge Voltage Setting	0x0000	0mV
0x3F	InputCurrent()	Read or Write	6-Bit Input Current Setting	0x0080	256mA (10m $\Omega$ RAC)
0xFE	ManufacturerID()	Read Only	Manufacturer ID	0x0040	–
0xFF	DeviceID()	Read Only	Device ID	0x0007	–

### 8.5.1.1 SMBus Interface

The bq24765 operates as a slave, receiving control inputs from the embedded controller host through the SMBus interface.

The bq24765 receives control inputs from the SMBus interface. The bq24765 uses a simplified subset of the commands documented in System Management Bus Specification V1.1, which can be downloaded from [www.smbus.org](http://www.smbus.org). The bq24765 uses the SMBus Read-Word and Write-Word protocols (see Figure 14) to communicate with the smart battery. The bq24765 performs only as an SMBus slave device with address 0b0001001\_ (0x12) and does not initiate communication on the bus. In addition, the bq24765 has two identification (ID) registers (0xFE): a 16-bit device ID register and a 16-bit manufacturer ID register (0xFF).

The data (SDA) and clock (SCL) pins have Schmitt-trigger inputs that can accommodate slow edges. Choose pullup resistors (10 kΩ) for SDA and SCL to achieve rise times according to the SMBus specifications.

Communication starts when the master signals a START condition, which is a high-to-low transition on SDA, while SCL is high. When the master has finished communicating, the master issues a STOP condition, which is a low-to-high transition on SDA, while SCL is high. The bus is then free for another transmission. Figure 15 and Figure 16 show the timing diagram for signals on the SMBus interface. The address byte, command byte, and data bytes are transmitted between the START and STOP conditions. The SDA state changes only while SCL is low, except for the START and STOP conditions. Data is transmitted in 8-bit bytes and is sampled on the rising edge of SCL. Nine clock cycles are required to transfer each byte in or out of the bq24765 because either the master or the slave acknowledges the receipt of the correct byte during the ninth clock cycle.

#### a) Write-Word Format

S	SLAVE ADDRESS	W	ACK	COMMAND BYTE	ACK	LOW DATA BYTE	ACK	HIGH DATA BYTE	ACK	P
	7 BITS	1b	1b	8 BITS	1b	8 BITS	1b	8 BITS	1b	
	MSB LSB	0	0	MSB LSB	0	MSB LSB	0	MSB L SB	0	

Preset to 0b0001001

**ChargerMode() = 0x12** D7 D0  
**ChargeCurrent() = 0x14**  
**ChargeVoltage() = 0x15**  
**InputCurrent() = 0x3F** D15 D8

#### b) Read-Word Format

S	SLAVE ADDRESS	W	ACK	COMMAND BYTE	ACK	S	SLAVE ADDRESS	R	ACK	LOW DATA BYTE	ACK	HIGH DATA BYTE	NACK	P
	7 BITS	1b	1b	8 BITS	1b		7 BITS	1b	1b	8 BITS	1b	8 BITS	1b	
	MSB LSB	0	0	MSB LSB	0		MSB LSB	1	0	MSB LSB	0	MSB LSB	1	

Preset to 0b0001001

Register Preset to 0b0001001  
**ChargerMode() = 0x12** D7 D0  
**ChargerMode() = 0x14** D15 D8  
**ChargerMode() = 0x15**  
**ChargerMode() = 0x3F**

#### LEGEND:

S = START CONDITION OR REPEATED START CONDITION

ACK = ACKNOWLEDGE (LOGIC-LOW)

W = WRITE BIT (LOGIC-LOW)

P = STOP CONDITION

NACK = NOT ACKNOWLEDGE (LOGIC-HIGH)

R = READ BIT (LOGIC-HIGH)

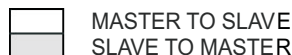

**Figure 14. SMBus Write-Word and Read-Word Protocols**

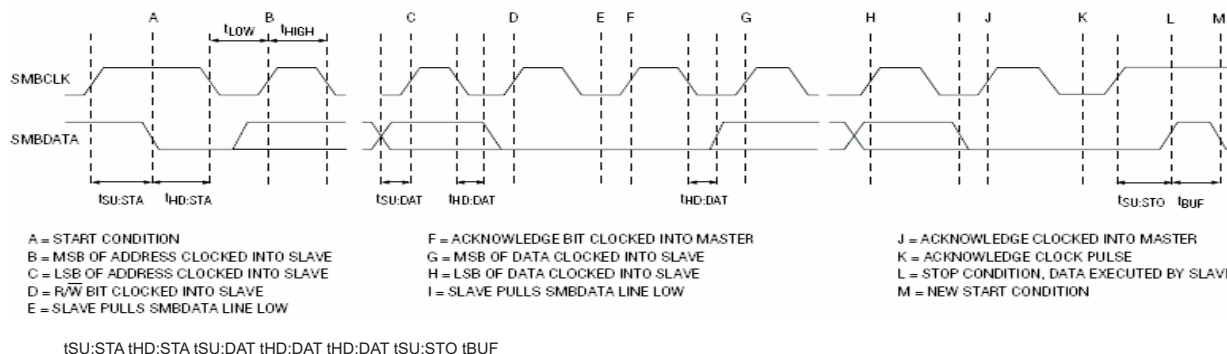

**Figure 15. SMBus Write Timing**

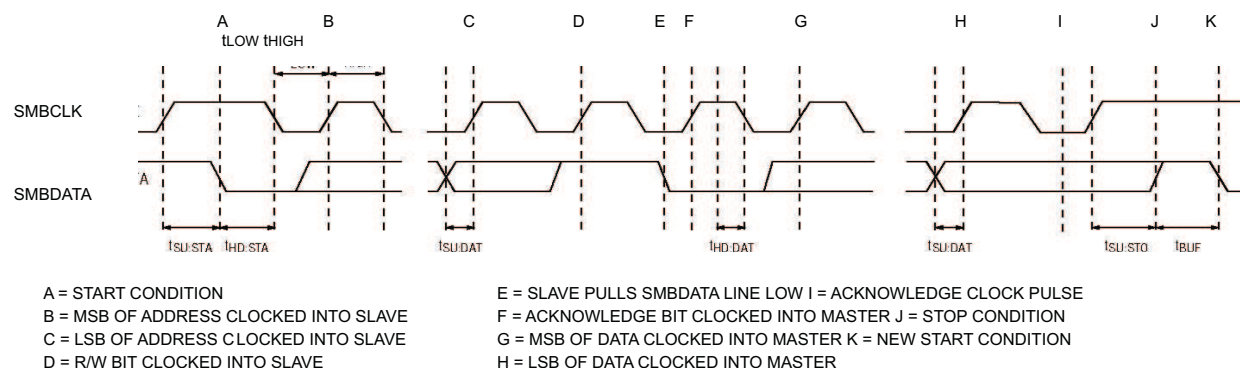

**Figure 16. SMBus Read Timing**

### 8.5.2 Battery Voltage Regulation

The bq24765 uses a high-accuracy voltage regulator for charging voltage. The battery voltage regulation setting is programmed by the host microcontroller ( $\mu\text{C}$ ), through the SMBus interface that sets an 11 bit DAC. The battery termination voltage is function of the battery chemistry. Consult the battery manufacturer to determine this voltage.

The VFB pin is used to sense the battery voltage for voltage regulation and should be connected as close to the battery as possible, or directly on the output capacitor. A 0.1- $\mu\text{F}$  ceramic capacitor from VFB to AGND is recommended to be as close to the VFB pin as possible to decouple high frequency noise.

To set the output charge voltage regulation limit, use the SMBus to write a 16 bit ChargeVoltage() command using the data format listed in Table 3. The ChargeVoltage() command uses the Write-Word protocol (see Figure 14). The command code for ChargeVoltage() is 0x15 (0b00010101). The bq24765 provides a 1.024-V to 19.200-V charge voltage range, with 16 mV resolution. Setting ChargeVoltage() below 1.024 V or above 19.2 V clears DAC, and terminates charge.

Upon reset, the ChargeVoltage() and ChargeCurrent() values are cleared (0) and the charger remains off until both the ChargeVoltage() and the ChargeCurrent() command are sent. During reset, both high side and low side fets remain off until the charger gets started.

### 8.5.3 Battery Current Regulation

The Charge Current SMBus 6 bit DAC register sets the maximum charging current. Battery current is sensed by resistor RSR connected between CSOP and CSON. The maximum full-scale differential voltage between CSOP and CSON is 80.64 mV. Thus, for a 0.010- $\Omega$  sense resistor, the maximum charging current is 8.064 A.

The CSOP and CSON pins are used to sense across RSR with default value of 10 m $\Omega$ . However, resistors of other values can also be used. For a larger the sense resistor, you get a larger sense voltage, and a higher regulation accuracy; but, at the expense of higher conduction loss.

To set the charge current, use the SMBus to write a 16bit ChargeCurrent() command using the data format listed in [Table 4](#). The ChargeCurrent() command uses the Write-Word protocol (see [Figure 14](#)). The command code for ChargeCurrent() is 0x14 (0b00010100). When using a 10-mΩ sense resistor, the bq24765 provides a charge current range of 128 mA to 8.064 A, with 128 mA resolution. Set ChargeCurrent() to 0 to terminate charging. Setting ChargeCurrent() below 128 mA, or above 8.064 A clears DAC and terminates charge

As charging goes on, the power loss on the switching fets causes the junction temperature to rise. The bq24765 provides a thermal regulation loop to throttle back the maximum charge current when the maximum junction temperature limit is reached. Once the device junction temperature exceeds thermal regulation limit (typical 120°C), the thermal regulator reduces the charging current to keep the junction temperature at 120°C. When the junction temperature rises to 125°C, the charging current decreases down close to 0 A.

The bq24765 includes a foldback current limit when the battery voltage is low. If the battery voltage is less than 3.6 V but above 2.5 V, any charge current limit above 3 A will be clamped at 3 A. If the battery voltage is less than 2.5 V, the charge current is set to 220 mA until that voltage rises above 2.7 V. The ChargeCurrent() register is preserved and becomes active again when the battery voltage is higher than 2.7 V. This function effectively provides a fold-back current limit, which protects the charger during short circuit and overload.

Upon reset, the ChargeVoltage() and ChargeCurrent() values are cleared (0) and the charger remains off until both the ChargeVoltage() and the ChargeCurrent() command are sent. During reset, both high side and low side fets remain off until the charger gets started.

#### 8.5.4 Input Adapter Current Regulation

The total Input Current from an AC adapter or other DC sources is a function of the system supply current and the battery charging current. System current normally fluctuates as portions of the system are powered up or down. Without Dynamic Power Management (DPM), the source must be able to supply the maximum system current and the maximum charger input current simultaneously. By using DPM, the input current regulator reduces the charging current to keep the input current from exceeding the limit set by the Input Current SMBus 6 bit DAC register. With the high accuracy limiting, the current capability of the AC adaptor can be lowered, reducing system cost.

The CSSP and CSSN pins are used to sense  $R_{AC}$  with default value of 10 mΩ. However, resistors of other values can also be used. For a larger the sense resistor, you get a larger sense voltage, and a higher regulation accuracy; but, at the expense of higher conduction loss.

The total input current, from a wall cube or other DC source, is the sum of the system supply current and the current required by the charger. When the input current exceeds the set input current limit, the bq24765 decreases the charge current to provide priority to system load current. As the system supply rises, the available charge current drops linearly to zero.

where  $\eta$  is the efficiency of the DC-DC converter (typically 85% to 95%).

$$I_{INPUT} = I_{LOAD} + \left[ \frac{I_{LOAD} \times V_{BATTERY}}{V_{IN} \times \eta} \right] + I_{BIAS} \quad (2)$$

To set the input current limit, use the SMBus to write a 16-bit InputCurrent() command using the data format listed in [Table 5](#). The InputCurrent() command uses the Write-Word protocol (see [Figure 14](#)). The command code for InputCurrent() is 0x3F (0b00111111). When using a 10-mΩ sense resistor, the bq24765 provides an input-current limit range of 256 mA to 11.004 A, with 256 mA resolution. InputCurrent() settings from 1 mA to 256 mA clears DAC and terminates charge. Upon reset the input current limit is 256 mA.

## 8.6 Register Maps

**Table 3. Charge Voltage Register (0x15)**

BIT	BIT NAME	DESCRIPTION
0	–	Not used
1	–	Not used
2	–	Not used
3	–	Not used
4	Charge Voltage, DACV 0	0 = Adds 0 mV of charger voltage, 1024 mV min 1 = Adds 16 mV of charger voltage
5	Charge Voltage, DACV 1	0 = Adds 0 mV of charger voltage, 1024 mV min 1 = Adds 32 mV of charger voltage
6	Charge Voltage, DACV 2	0 = Adds 0 mV of charger voltage, 1024 mV min 1 = Adds 64 mV of charger voltage
7	Charge Voltage, DACV 3	0 = Adds 0 mV of charger voltage, 1024 mV min 1 = Adds 128 mV of charger voltage.
8	Charge Voltage, DACV 4	0 = Adds 0 mV of charger voltage, 1024 mV min 1 = Adds 256 mV of charger voltage.
9	Charge Voltage, DACV 5	0 = Adds 0 mV of charger voltage, 1024 mV min 1 = Adds 512 mV of charger voltage.
10	Charge Voltage, DACV 6	0 = Adds 0 mV of charger voltage 1 = Adds 1024 mV of charger voltage
11	Charge Voltage, DACV 7	0 = Adds 0 mV of charger voltage 1 = Adds 2048 mV of charger voltage
12	Charge Voltage, DACV 8	0 = Adds 0 mV of charger voltage 1 = Adds 4096 mV of charger voltage
13	Charge Voltage, DACV 9	0 = Adds 0 mV of charger voltage 1 = Adds 8192 mV of charger voltage
14	Charge Voltage, DACV 10	0 = Adds 0 mV of charger voltage 1 = Adds 16384 mV of charger voltage
15	–	Not used

**Table 4. Charge Current Register (0x14), Using 10-m $\Omega$  Sense Resistor**

BIT	BIT NAME	DESCRIPTION
0	–	Not used
1	–	Not used
2	–	Not used
3	–	Not used
4	–	Not used
5	–	Not used
6	–	Not used
7	Charge Current, DACI 0	0 = Adds 0 mA of charger current 1 = Adds 128 mA of charger current.
8	Charge Current, DACI 1	0 = Adds 0 mA of charger current 1 = Adds 256 mA of charger current.
9	Charge Current, DACI 2	0 = Adds 0 mA of charger current 1 = Adds 512 mA of charger current.
10	Charge Current, DACI 3	0 = Adds 0 mA of charger current 1 = Adds 1024 mA of charger current.
11	Charge Current, DACI 4	0 = Adds 0 mA of charger current 1 = Adds 2048 mA of charger current.
12	Charge Current, DACI 5	0 = Adds 0 mA of charger current 1 = Adds 4096 mA of charger current, (Maximum charge current 8064 mA.)
13	–	Not used
14	–	Not used
15	–	Not used

**Table 5. Input Current Register (0x3f), Using 10-m $\Omega$  Sense Resistor**

BIT	BIT NAME	DESCRIPTION
0	–	Not used
1	–	Not used
2	–	Not used
3	–	Not used
4	–	Not used
5	–	Not used
6	–	Not used
7	Charge Current, DACS 0	0 = Adds 0 mA of charger current 1 = Adds 256 mA of charger current.
8	Charge Current, DACS 1	0 = Adds 0 mA of charger current 1 = Adds 512 mA of charger current.
9	Charge Current, DACS 2	0 = Adds 0 mA of charger current 1 = Adds 1024 mA of charger current.
10	Charge Current, DACS 3	0 = Adds 0 mA of charger current 1 = Adds 2048 mA of charger current.
11	Charge Current, DACS 4	0 = Adds 0 mA of charger current 1 = Adds 4096 mA of charger current, (Maximum charge current 8064 mA.)
12	Charge Current, DACS 5	0 = Adds 0 mA of charger current 1 = Adds 8192 mA of charger current, 11004 mA max)
13	–	Not used
14	–	Not used
15	–	Not used

## 9 Application and Implementation

### NOTE

Information in the following applications sections is not part of the TI component specification, and TI does not warrant its accuracy or completeness. TI's customers are responsible for determining suitability of components for their purposes. Customers should validate and test their design implementation to confirm system functionality.

### 9.1 Application Information

The bq24765EVM-349 evaluation module (EVM) is a complete charger module for evaluating the bq24765. The application curves were taken using the bq24765EVM-349. Refer to the *bq24765 EVM (HPA349) User's Guide, SLUU415* for EVM information.

### 9.2 Typical Application

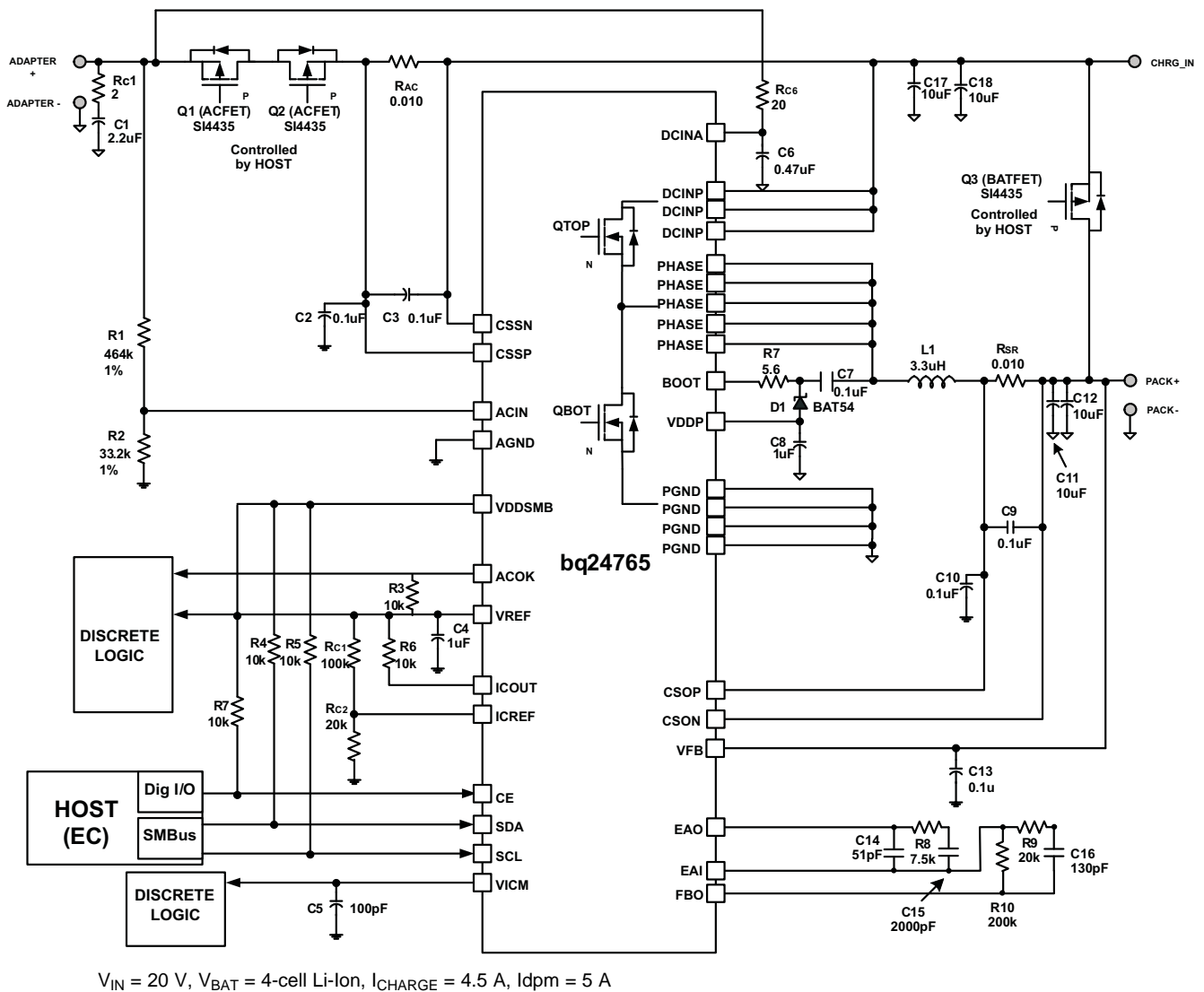

Figure 17. Typical System Schematic, Using Internal Input Current Comparator

## Typical Application (continued)

### 9.2.1 Design Requirements

For this design example, use the parameters listed in [Table 6](#).

**Table 6. Design Parameters**

DESIGN PARAMETER	EXAMPLE VALUE
Input Voltage <sup>(1)</sup>	17.7 V < Adapter Voltage < 24 V
Input Current Limit <sup>(1)</sup>	3.2 A for 65 W adapter
Battery Charge Voltage <sup>(2)</sup>	12592 mV for 3s battery
Battery Charge Current <sup>(2)</sup>	4096 mA for 3s battery
Battery Discharge Current <sup>(2)</sup>	6144 mA for 3s battery

- (1) Refer to adapter specification for Input Voltage and Input Current Limit.  
 (2) Refer to battery specification for settings.

### 9.2.2 Detailed Design Procedure

The parameters are configurable using the evaluation software, [SLVC309](#). The simplified application circuit (see [Figure 17](#)) shows the minimum capacitance requirements for each pin. Inductor, capacitor, and MOSFET selection are explained in the rest of this section. Refer to the *bq24765 EVM (HPA349) User's Guide*, [SLUU415](#) for the full application schematic.

**Table 7. Component List For Typical System Circuit of bq24765**

PART DESIGNATOR	Qty	DESCRIPTION
Q1, Q2, Q6	3	P-channel MOSFET, –30 V, –7.5 A, SO-8, Vishay-Siliconix, Si4835
RAC, RSR	2	Sense Resistor, 10 mΩ, 1 W, 2010, Vishay-Dale, WSL2010R0100F
L1	1	Inductor, 2.2 μH, 8 A, 20 mΩ, Vishay, IHLP2525CZ01-2R2
4xC2, 2xC9, 3xC13	9	Capacitor, Ceramic, 10 μF, 35 V, 20%, X5R, 1206, Panasonic, ECJ-3YB1E106M
C1	1	Capacitor, Ceramic, 2.2 μF, 25 V, 1210
C3, C7, C11	3	Capacitor, Ceramic, 1 μF, 25 V, 10%, X7R, 2012, TDK, C2012X7R1E105K
C6	1	Capacitor, Ceramic, 0.47 μF, 25 V, 0805
C4, C5, C10, C11, C12, C13, C15	7	Capacitor, Ceramic, 0.1 μF, 50 V, 10%, X7R, 0805, Kemet, C0805C104K5RACTU
C8	1	Capacitor, Ceramic, 100 pF, 25 V, 10%, X7R, 0805, Kemet
C16	1	Capacitor, Ceramic, 51 pF, 25 V, 10%, X7R, 0805, Kemet
C17	1	Capacitor, Ceramic, 2000 pF, 25 V, 10%, X7R, 0805, Kemet
C18	1	Capacitor, Ceramic, 130 pF, 25 V, 10%, X7R, 0805, Kemet
RC1	1	Resistor, thick film chip paralleling, 2x3.9 Ω, 25 V, 1210
RC6	1	Resistor, thick film chip, 20 Ω, 0805
R3, R4, R5, R6, R7	5	Resistor, Chip, 10 kΩ, 1/16 W, 5%, 0402
R1	1	Resistor, Chip, 309 kΩ, 1/16 W, 1%, 0402
R2	1	Resistor, Chip, 49.9 kΩ, 1/16 W, 1%, 0402
R8	1	Resistor, Chip, 51.1 kΩ, 1/16 W, 1%, 0402
R9	1	Resistor, Chip, 17.4 kΩ, 1/16 W, 1%, 0402
R10	1	Resistor, Chip, 7.5 kΩ, 1/16 W, 5%, 0402
R11	1	Resistor, Chip, 4.7 kΩ, 1/16 W, 5%, 0402
R12	1	Resistor, Chip, 200 kΩ, 1/16 W, 5%, 0402
R13	1	Resistor, Chip, 1.4 MegΩ, 1/16 W, 1%, 0402

9.2.3 Application Curves

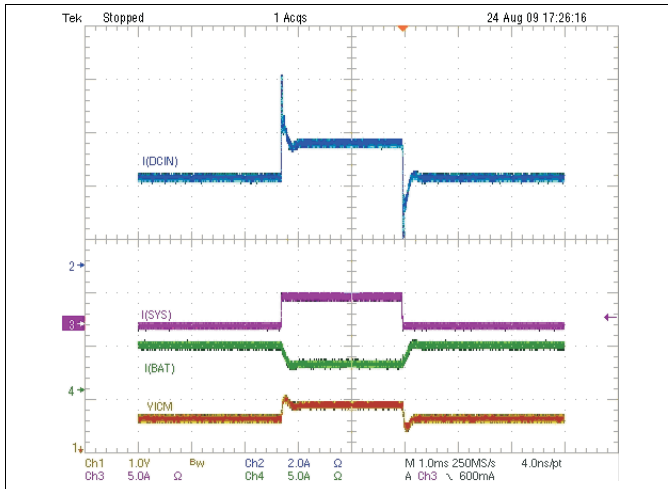

Figure 18. Transient System Load (DPM) Response: Charge Current Dropped From 4A to 2A

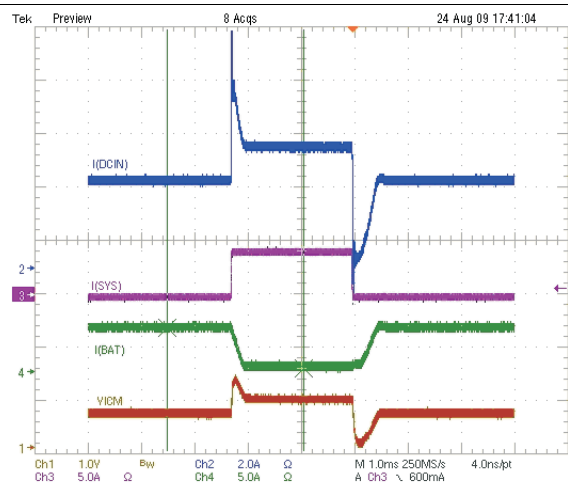

Figure 19. Transient System Load (DPM) Response: Charge Current Dropped From 4A to 0A

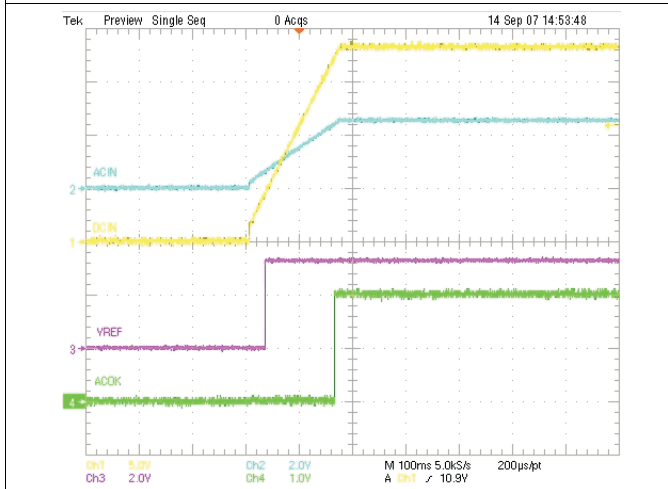

Figure 20. Charger When Adapter Inserted

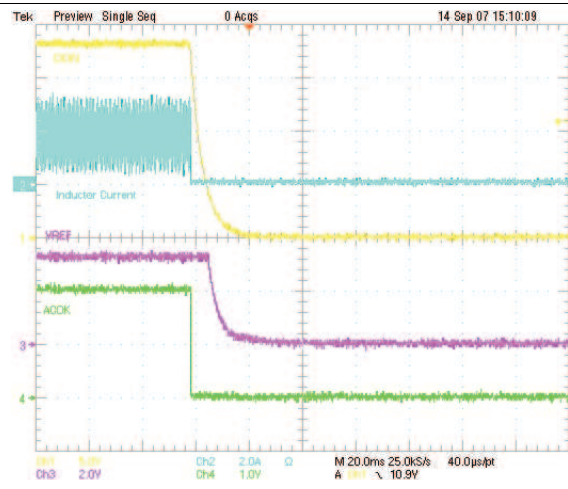

Figure 21. Charger When Adapter Removed

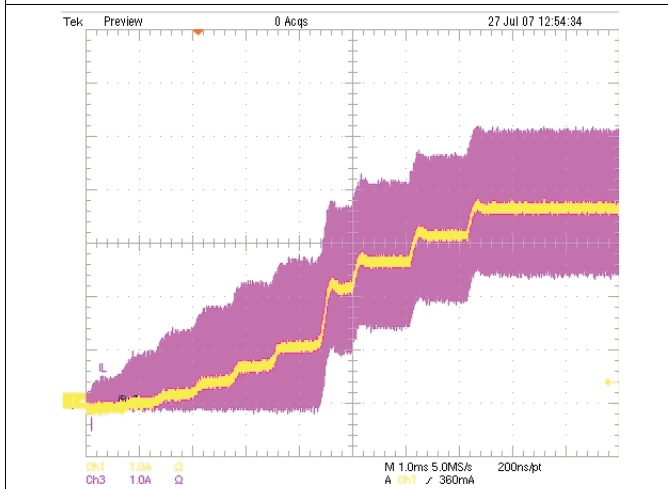

Figure 22. Inductor Current and Battery Current Soft-Start

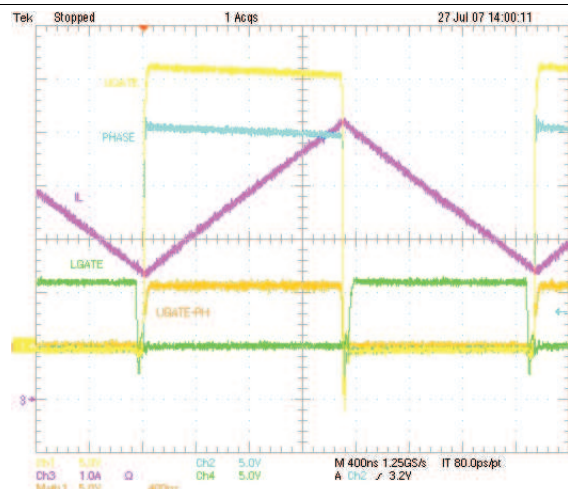

Figure 23. Continuous Conduction Mode (CCM) Switching Waveforms

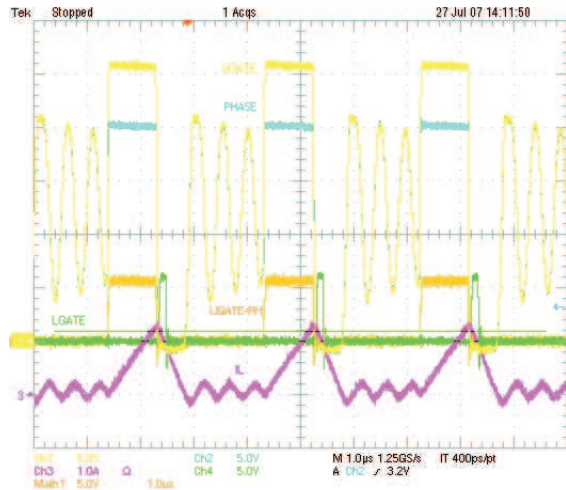

Figure 24. Discontinuous Conduction Mode (DCM) Switching Waveforms

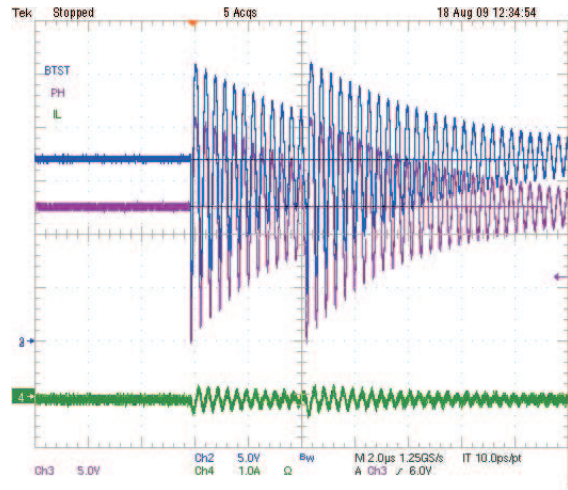

Figure 25. Near 100% Duty Cycle Bootstrap Recharge Pulse

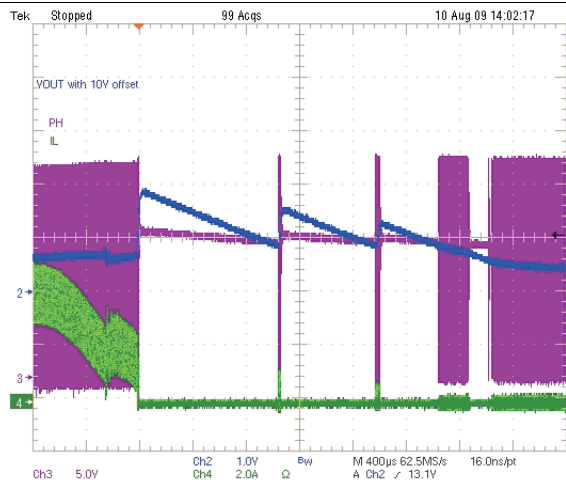

Figure 26. Battery Removal (From Constant Current Mode)

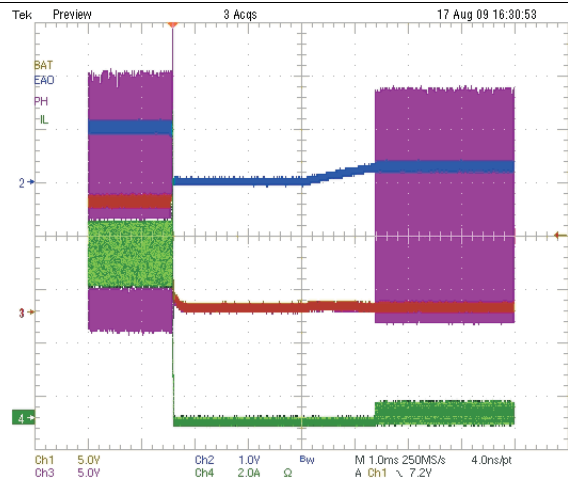

Figure 27. Battery Shorted Charger Response, Reset Charger

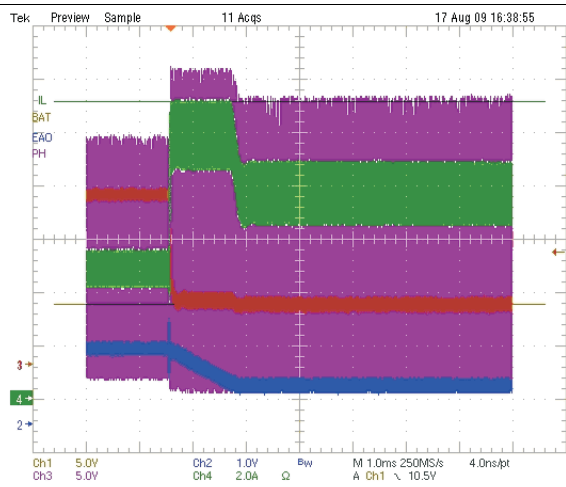

Figure 28. Power FET Overcurrent Protection

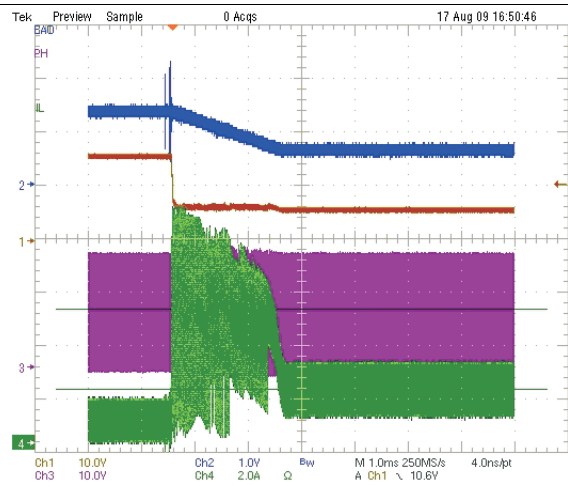
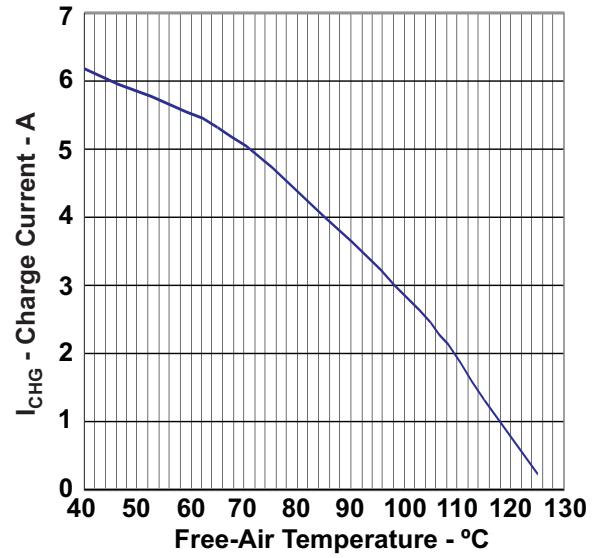
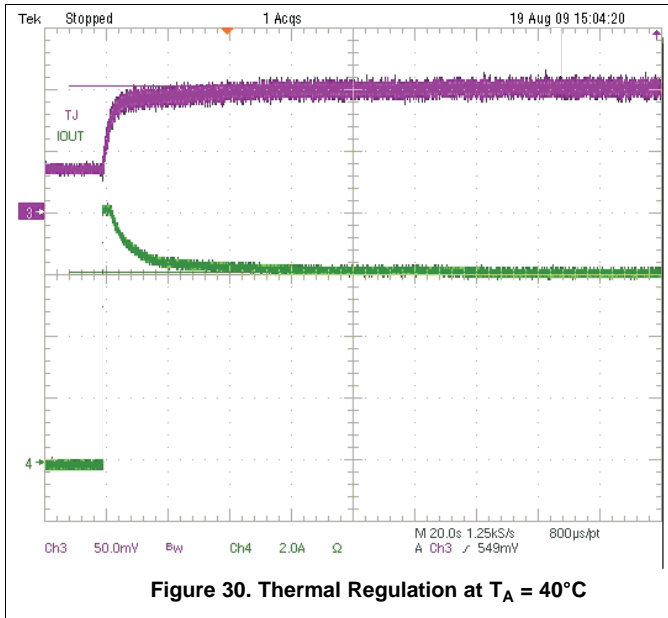

Figure 29. Charge Overcurrent Protection



## 10 Power Supply Recommendations

The bq24765 requires a minimum 4.5 V DCINA voltage to allow proper operation. To have 6 V VDDP voltage and high efficiency operation, a 7-V to 24-V power supply voltage range is recommended.

## 11 Layout

### 11.1 Layout Guidelines

It is critical that the exposed power pad on the backside of the IC package be soldered to the PCB ground. Ensure that there are sufficient thermal vias directly under the IC, connecting to the ground plane on the other layers. The control stage and the power stage should be routed separately. At each layer, the signal ground and the power ground are connected only at the power pad.

- The AC current-sense resistor must be connected to CSSP (pin 28) and CSSN (pin 27) with a Kelvin contact. The area of this loop must be minimized. The decoupling capacitors for these pins should be placed as close to the IC as possible.
- The charge-current sense resistor must be connected to CSOP (pin 18), CSON (pin 17) with a Kelvin contact. The area of this loop must be minimized. The decoupling capacitors for these pins should be placed as close to the IC as possible.
- Decoupling capacitors for DCIN (pin 22), VREF (pin 3), and VDDP (pin 21) should be placed underneath the IC (on the bottom layer) with the interconnections to the IC as short as possible.
- Decoupling capacitors for VFB (pin 15), VICM (pin 8), and VDDSMB (pin 11) must be placed close to the corresponding IC pins with the interconnections to the IC as short as possible. Decoupling capacitors for BOOT (pin 25) must be placed close to the corresponding IC pins with the interconnections to the IC as short as possible.
- Decoupling capacitor for the charger input must be placed very close to the top switch drains and bottom source. Make the loop from input capacitor to top switch drain, top switch source, bottom switch drain, bottom switch source and return back to input capacitor power ground as small as possible.
- Make the loop from top switch source (bottom switch drain) to inductor, output capacitor, and return back to bottom switch source power ground as small as possible.
- The pcb area for top switch source and bottom switch drain should keep as small as possible to reduce EMI but keep large enough for thermal release.
- Feedback loop compensation components should be placed close to the IC EAI (pin 5), EAO (pin 4), and FBO (pin 6) with the interconnections to the IC as short as possible.
- IC UGATE (pin 24), PHASE (pin 23), and LGATE (pin 20) should use short interconnections to the MOSFET terminals to reduce parasitic inductance. LGATE (pin 20) should keep distance from PHASE (pin 23) to avoid high dv/dt noise. Make the loop from UGATE (pin 24) to top switch gate, top switch source, and return back to PHASE (pin 23) as small as possible.

## 11.2 Layout Example

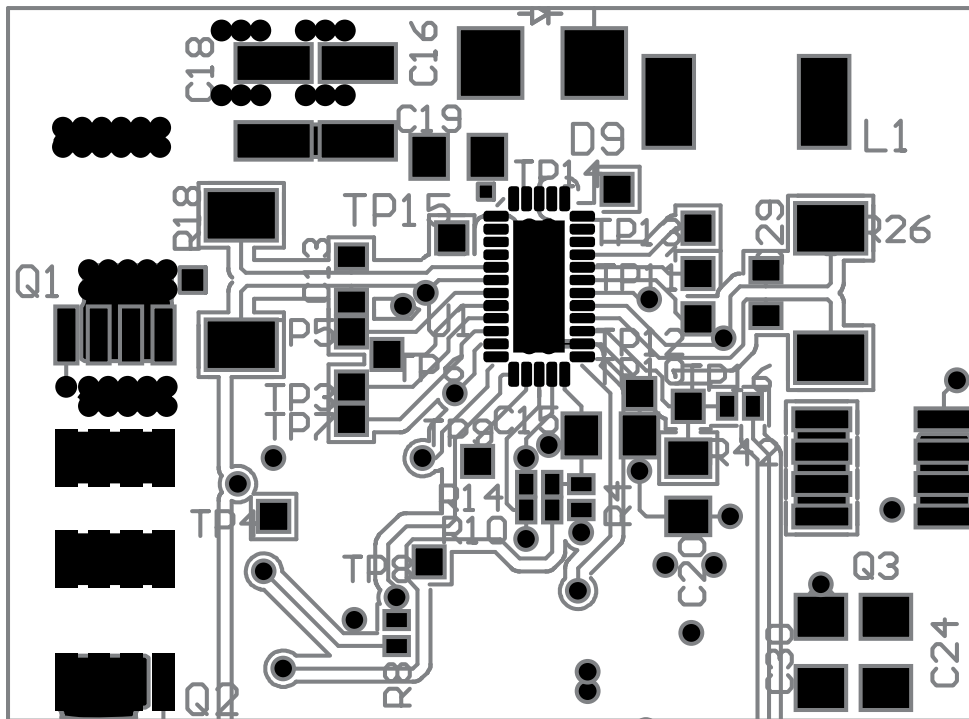

**Figure 32. bq24765 Board Layout**

## 12 Device and Documentation Support

### 12.1 Device Support

#### 12.1.1 Third-Party Products Disclaimer

TI'S PUBLICATION OF INFORMATION REGARDING THIRD-PARTY PRODUCTS OR SERVICES DOES NOT CONSTITUTE AN ENDORSEMENT REGARDING THE SUITABILITY OF SUCH PRODUCTS OR SERVICES OR A WARRANTY, REPRESENTATION OR ENDORSEMENT OF SUCH PRODUCTS OR SERVICES, EITHER ALONE OR IN COMBINATION WITH ANY TI PRODUCT OR SERVICE.

#### 12.1.2 Device Nomenclature

**VICM** Output Voltage of Input Current Monitor

**ICREF** Input Current Reference - sets the threshold for the input current limit

**DPM** Dynamic Power Management

**CSOP, CSON** Current Sense Output of battery positive and negative

These pins are used with an external low-value series resistor to monitor the current to and from the battery pack.

**CSSP, CSSN** Current Sense Supply positive and negative

These pins are used with an external low-value series resistor to monitor the current from the adapter supply.

**POR** Power on reset

### 12.2 Documentation Support

#### 12.2.1 Related Documentation

- [bq24765 EVM \(HPA349\) User's Guide, SLUU415](#)
- [bq24765 SMB evaluation software SLVC309](#)

### 12.3 Community Resources

The following links connect to TI community resources. Linked contents are provided "AS IS" by the respective contributors. They do not constitute TI specifications and do not necessarily reflect TI's views; see TI's [Terms of Use](#).

**TI E2E™ Online Community** *TI's Engineer-to-Engineer (E2E) Community*. Created to foster collaboration among engineers. At [e2e.ti.com](http://e2e.ti.com), you can ask questions, share knowledge, explore ideas and help solve problems with fellow engineers.

**Design Support** *TI's Design Support* Quickly find helpful E2E forums along with design support tools and contact information for technical support.

### 12.4 Trademarks

E2E is a trademark of Texas Instruments.  
All other trademarks are the property of their respective owners.

### 12.5 Electrostatic Discharge Caution



These devices have limited built-in ESD protection. The leads should be shorted together or the device placed in conductive foam during storage or handling to prevent electrostatic damage to the MOS gates.

### 12.6 Glossary

[SLYZ022](#) — *TI Glossary*.

This glossary lists and explains terms, acronyms, and definitions.

### 13 Mechanical, Packaging, and Orderable Information

The following pages include mechanical, packaging, and orderable information. This information is the most current data available for the designated devices. This data is subject to change without notice and revision of this document. For browser-based versions of this data sheet, refer to the left-hand navigation.

**PACKAGING INFORMATION**

Orderable Device	Status (1)	Package Type	Package Drawing	Pins	Package Qty	Eco Plan (2)	Lead/Ball Finish	MSL Peak Temp (3)	Op Temp (°C)	Top-Side Markings (4)	Samples
BQ24765RUVR	ACTIVE	VQFN	RUV	34	3000	Green (RoHS & no Sb/Br)	CU NIPDAU	Level-2-260C-1 YEAR	-40 to 155	BQ24765	<a href="#">Samples</a>
BQ24765RUVT	ACTIVE	VQFN	RUV	34	250	Green (RoHS & no Sb/Br)	CU NIPDAU	Level-2-260C-1 YEAR	-40 to 155	BQ24765	<a href="#">Samples</a>

(1) The marketing status values are defined as follows:

**ACTIVE:** Product device recommended for new designs.

**LIFEBUY:** TI has announced that the device will be discontinued, and a lifetime-buy period is in effect.

**NRND:** Not recommended for new designs. Device is in production to support existing customers, but TI does not recommend using this part in a new design.

**PREVIEW:** Device has been announced but is not in production. Samples may or may not be available.

**OBSOLETE:** TI has discontinued the production of the device.

(2) Eco Plan - The planned eco-friendly classification: Pb-Free (RoHS), Pb-Free (RoHS Exempt), or Green (RoHS & no Sb/Br) - please check <http://www.ti.com/productcontent> for the latest availability information and additional product content details.

**TBD:** The Pb-Free/Green conversion plan has not been defined.

**Pb-Free (RoHS):** TI's terms "Lead-Free" or "Pb-Free" mean semiconductor products that are compatible with the current RoHS requirements for all 6 substances, including the requirement that lead not exceed 0.1% by weight in homogeneous materials. Where designed to be soldered at high temperatures, TI Pb-Free products are suitable for use in specified lead-free processes.

**Pb-Free (RoHS Exempt):** This component has a RoHS exemption for either 1) lead-based flip-chip solder bumps used between the die and package, or 2) lead-based die adhesive used between the die and leadframe. The component is otherwise considered Pb-Free (RoHS compatible) as defined above.

**Green (RoHS & no Sb/Br):** TI defines "Green" to mean Pb-Free (RoHS compatible), and free of Bromine (Br) and Antimony (Sb) based flame retardants (Br or Sb do not exceed 0.1% by weight in homogeneous material)

(3) MSL, Peak Temp. -- The Moisture Sensitivity Level rating according to the JEDEC industry standard classifications, and peak solder temperature.

(4) Multiple Top-Side Markings will be inside parentheses. Only one Top-Side Marking contained in parentheses and separated by a "~" will appear on a device. If a line is indented then it is a continuation of the previous line and the two combined represent the entire Top-Side Marking for that device.

**Important Information and Disclaimer:** The information provided on this page represents TI's knowledge and belief as of the date that it is provided. TI bases its knowledge and belief on information provided by third parties, and makes no representation or warranty as to the accuracy of such information. Efforts are underway to better integrate information from third parties. TI has taken and continues to take reasonable steps to provide representative and accurate information but may not have conducted destructive testing or chemical analysis on incoming materials and chemicals. TI and TI suppliers consider certain information to be proprietary, and thus CAS numbers and other limited information may not be available for release.

In no event shall TI's liability arising out of such information exceed the total purchase price of the TI part(s) at issue in this document sold by TI to Customer on an annual basis.

**TAPE AND REEL INFORMATION**

**REEL DIMENSIONS**

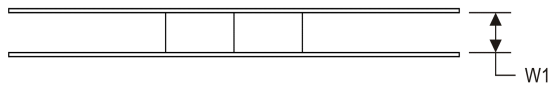
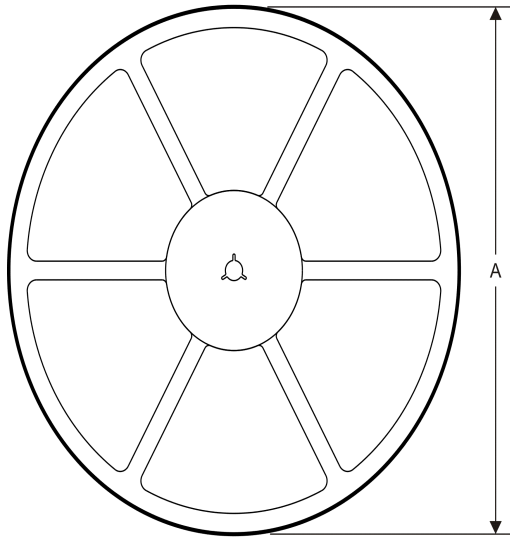

**TAPE DIMENSIONS**

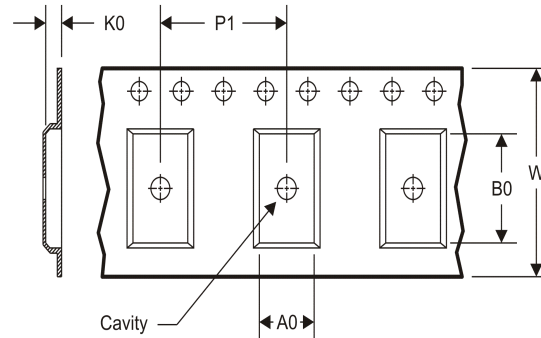

A0	Dimension designed to accommodate the component width
B0	Dimension designed to accommodate the component length
K0	Dimension designed to accommodate the component thickness
W	Overall width of the carrier tape
P1	Pitch between successive cavity centers

**TAPE AND REEL INFORMATION**

\*All dimensions are nominal

Device	Package Type	Package Drawing	Pins	SPQ	Reel Diameter (mm)	Reel Width W1 (mm)	A0 (mm)	B0 (mm)	K0 (mm)	P1 (mm)	W (mm)	Pin1 Quadrant
BQ24765RUVR	VQFN	RUV	34	3000	330.0	16.4	3.85	7.35	1.2	8.0	16.0	Q1
BQ24765RUVT	VQFN	RUV	34	250	180.0	16.4	3.85	7.35	1.2	8.0	16.0	Q1

**TAPE AND REEL BOX DIMENSIONS**

\*All dimensions are nominal

Device	Package Type	Package Drawing	Pins	SPQ	Length (mm)	Width (mm)	Height (mm)
BQ24765RUVR	VQFN	RUV	34	3000	367.0	367.0	38.0
BQ24765RUVT	VQFN	RUV	34	250	210.0	185.0	35.0

RUV (R-PVQFN-N34)

PLASTIC QUAD FLATPACK NO-LEAD

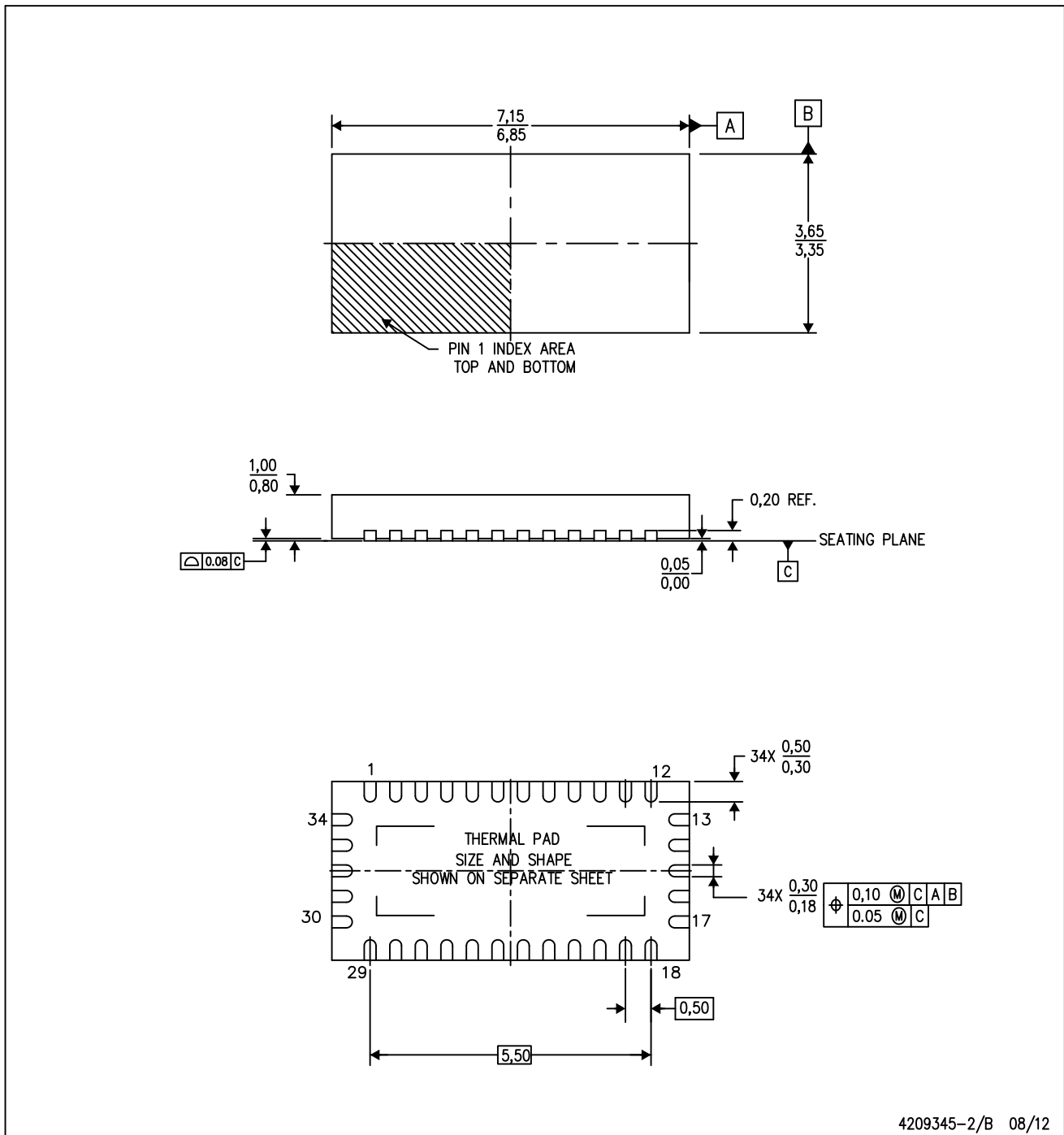

- NOTES:
- All linear dimensions are in millimeters. Dimensioning and tolerancing per ASME Y14.5M-1994.
  - This drawing is subject to change without notice.
  - Quad Flatpack, No-leads (QFN) package configuration.
  - The package thermal pad must be soldered to the board for thermal and mechanical performance.
  - See the additional figure in the Product Data Sheet for details regarding the exposed thermal pad features and dimensions.
  - Falls within JEDEC MO-220.

# THERMAL PAD MECHANICAL DATA

RUV (S-PVQFN-N34)

PLASTIC QUAD FLATPACK NO-LEAD

## THERMAL INFORMATION

This package incorporates an exposed thermal pad that is designed to be attached directly to an external heatsink. The thermal pad must be soldered directly to the printed circuit board (PCB). After soldering, the PCB can be used as a heatsink. In addition, through the use of thermal vias, the thermal pad can be attached directly to the appropriate copper plane shown in the electrical schematic for the device, or alternatively, can be attached to a special heatsink structure designed into the PCB. This design optimizes the heat transfer from the integrated circuit (IC).

For information on the Quad Flatpack No-Lead (QFN) package and its advantages, refer to Application Report, QFN/SON PCB Attachment, Texas Instruments Literature No. SLUA271. This document is available at [www.ti.com](http://www.ti.com).

The exposed thermal pad dimensions for this package are shown in the following illustration.

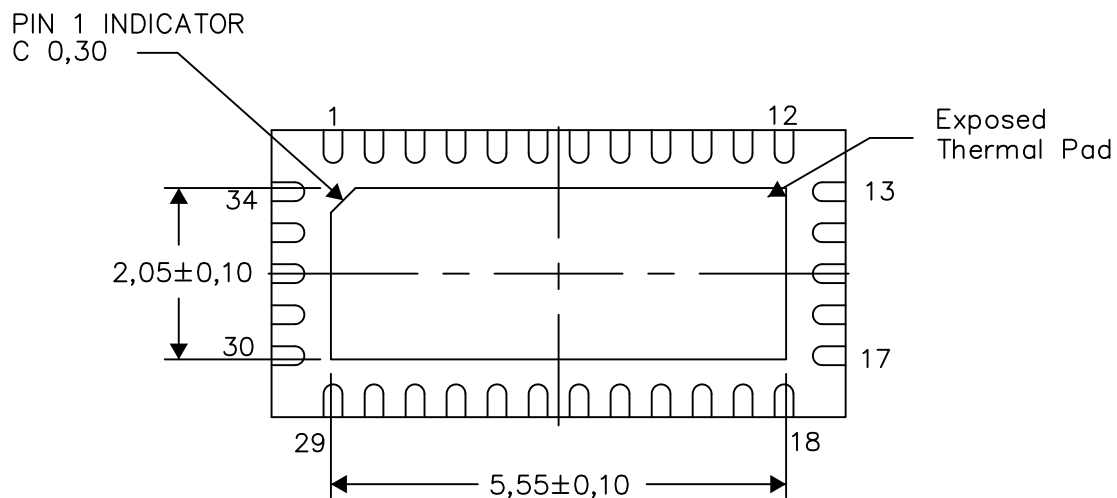

Bottom View

Exposed Thermal Pad Dimensions

4209552-3/E 06/13

NOTE: All linear dimensions are in millimeters

RUV (R-PVQFN-N34)

PLASTIC QUAD FLATPACK NO-LEAD

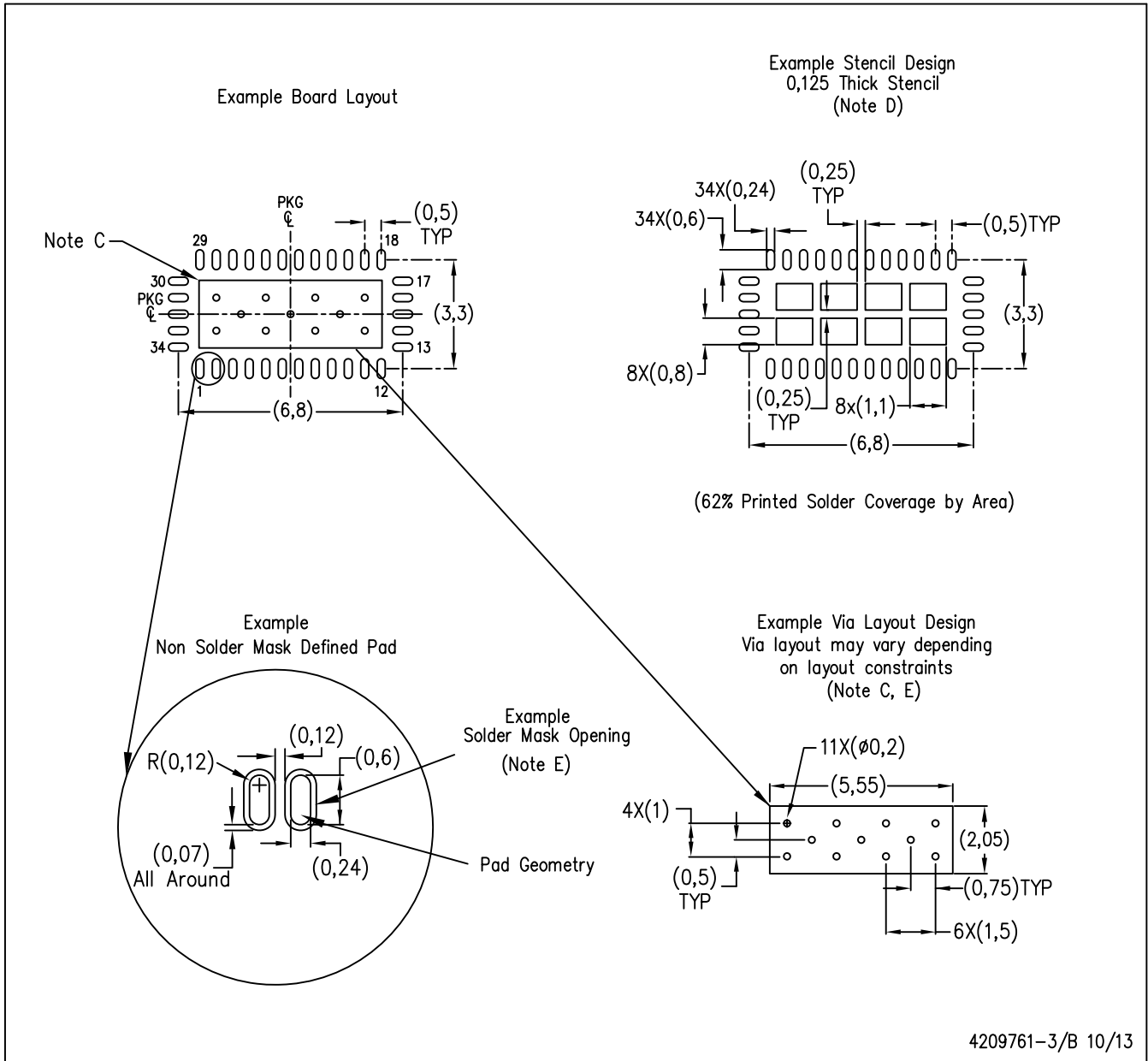

- NOTES:
- All linear dimensions are in millimeters.
  - This drawing is subject to change without notice.
  - This package is designed to be soldered to a thermal pad on the board. Refer to Application Note, Quad Flat-Pack Packages, Texas Instruments Literature No. SLUA271, and also the Product Data Sheets for specific thermal information, via requirements, and recommended board layout. These documents are available at [www.ti.com](http://www.ti.com) <<http://www.ti.com>>.
  - Laser cutting apertures with trapezoidal walls and also rounding corners will offer better paste release. Customers should contact their board assembly site for stencil design recommendations. Refer to IPC 7525 for stencil design considerations.
  - Customers should contact their board fabrication site for recommended solder mask tolerances and via tenting recommendations for vias placed in the thermal pad.

## IMPORTANT NOTICE

Texas Instruments Incorporated and its subsidiaries (TI) reserve the right to make corrections, enhancements, improvements and other changes to its semiconductor products and services per JESD46, latest issue, and to discontinue any product or service per JESD48, latest issue. Buyers should obtain the latest relevant information before placing orders and should verify that such information is current and complete. All semiconductor products (also referred to herein as "components") are sold subject to TI's terms and conditions of sale supplied at the time of order acknowledgment.

TI warrants performance of its components to the specifications applicable at the time of sale, in accordance with the warranty in TI's terms and conditions of sale of semiconductor products. Testing and other quality control techniques are used to the extent TI deems necessary to support this warranty. Except where mandated by applicable law, testing of all parameters of each component is not necessarily performed.

TI assumes no liability for applications assistance or the design of Buyers' products. Buyers are responsible for their products and applications using TI components. To minimize the risks associated with Buyers' products and applications, Buyers should provide adequate design and operating safeguards.

TI does not warrant or represent that any license, either express or implied, is granted under any patent right, copyright, mask work right, or other intellectual property right relating to any combination, machine, or process in which TI components or services are used. Information published by TI regarding third-party products or services does not constitute a license to use such products or services or a warranty or endorsement thereof. Use of such information may require a license from a third party under the patents or other intellectual property of the third party, or a license from TI under the patents or other intellectual property of TI.

Reproduction of significant portions of TI information in TI data books or data sheets is permissible only if reproduction is without alteration and is accompanied by all associated warranties, conditions, limitations, and notices. TI is not responsible or liable for such altered documentation. Information of third parties may be subject to additional restrictions.

Resale of TI components or services with statements different from or beyond the parameters stated by TI for that component or service voids all express and any implied warranties for the associated TI component or service and is an unfair and deceptive business practice. TI is not responsible or liable for any such statements.

Buyer acknowledges and agrees that it is solely responsible for compliance with all legal, regulatory and safety-related requirements concerning its products, and any use of TI components in its applications, notwithstanding any applications-related information or support that may be provided by TI. Buyer represents and agrees that it has all the necessary expertise to create and implement safeguards which anticipate dangerous consequences of failures, monitor failures and their consequences, lessen the likelihood of failures that might cause harm and take appropriate remedial actions. Buyer will fully indemnify TI and its representatives against any damages arising out of the use of any TI components in safety-critical applications.

In some cases, TI components may be promoted specifically to facilitate safety-related applications. With such components, TI's goal is to help enable customers to design and create their own end-product solutions that meet applicable functional safety standards and requirements. Nonetheless, such components are subject to these terms.

No TI components are authorized for use in FDA Class III (or similar life-critical medical equipment) unless authorized officers of the parties have executed a special agreement specifically governing such use.

Only those TI components which TI has specifically designated as military grade or "enhanced plastic" are designed and intended for use in military/aerospace applications or environments. Buyer acknowledges and agrees that any military or aerospace use of TI components which have **not** been so designated is solely at the Buyer's risk, and that Buyer is solely responsible for compliance with all legal and regulatory requirements in connection with such use.

TI has specifically designated certain components as meeting ISO/TS16949 requirements, mainly for automotive use. In any case of use of non-designated products, TI will not be responsible for any failure to meet ISO/TS16949.

### Products

Audio	<a href="http://www.ti.com/audio">www.ti.com/audio</a>
Amplifiers	<a href="http://amplifier.ti.com">amplifier.ti.com</a>
Data Converters	<a href="http://dataconverter.ti.com">dataconverter.ti.com</a>
DLP® Products	<a href="http://www.dlp.com">www.dlp.com</a>
DSP	<a href="http://dsp.ti.com">dsp.ti.com</a>
Clocks and Timers	<a href="http://www.ti.com/clocks">www.ti.com/clocks</a>
Interface	<a href="http://interface.ti.com">interface.ti.com</a>
Logic	<a href="http://logic.ti.com">logic.ti.com</a>
Power Mgmt	<a href="http://power.ti.com">power.ti.com</a>
Microcontrollers	<a href="http://microcontroller.ti.com">microcontroller.ti.com</a>
RFID	<a href="http://www.ti-rfid.com">www.ti-rfid.com</a>
OMAP Applications Processors	<a href="http://www.ti.com/omap">www.ti.com/omap</a>
Wireless Connectivity	<a href="http://www.ti.com/wirelessconnectivity">www.ti.com/wirelessconnectivity</a>

### Applications

Automotive and Transportation	<a href="http://www.ti.com/automotive">www.ti.com/automotive</a>
Communications and Telecom	<a href="http://www.ti.com/communications">www.ti.com/communications</a>
Computers and Peripherals	<a href="http://www.ti.com/computers">www.ti.com/computers</a>
Consumer Electronics	<a href="http://www.ti.com/consumer-apps">www.ti.com/consumer-apps</a>
Energy and Lighting	<a href="http://www.ti.com/energy">www.ti.com/energy</a>
Industrial	<a href="http://www.ti.com/industrial">www.ti.com/industrial</a>
Medical	<a href="http://www.ti.com/medical">www.ti.com/medical</a>
Security	<a href="http://www.ti.com/security">www.ti.com/security</a>
Space, Avionics and Defense	<a href="http://www.ti.com/space-avionics-defense">www.ti.com/space-avionics-defense</a>
Video and Imaging	<a href="http://www.ti.com/video">www.ti.com/video</a>

### TI E2E Community

[e2e.ti.com](http://e2e.ti.com)

## Looking for pricing, stock, or lifecycle information?

Click below to explore more details on WIN SOURCE:

 [View BQ24765RUVR](#) on WIN SOURCE

 [Texas Instruments](#) Information

## Optimize Your Supply Chain with WIN SOURCE Solutions

-  Global Sourcing Solution
-  Obsolete Management
-  Cost Control Management
-  Shortage Management
-  Alternative Solution
-  Excess Inventory Management