



THE DATASHEET OF TMP709AIDBVR



TMP709 Resistor-Programmable Temperature Switch in SOT Package

1 Features

- Threshold Accuracy:
 - $\pm 0.5^{\circ}\text{C}$ Typical
 - $\pm 3^{\circ}\text{C}$ Maximum (60°C to 100°C)
- Temperature Threshold Set By 1% External Resistor
- Low Quiescent Current: $40\ \mu\text{A}$ Typical
- Open-Drain, Active-Low Output Stage
- Pin-Selectable 2°C or 10°C Hysteresis
- Reset Operation Specified at $V_{\text{CC}} = 0.8\ \text{V}$
- Supply Range: $2.7\ \text{V}$ to $5.5\ \text{V}$
- Package: 5-Pin SOT-23

2 Applications

- Computers (Laptops and Desktops)
- Servers
- Industrial and Medical Equipment
- Storage Area Networks
- Automotive

3 Description

The TMP709 is a fully-integrated, resistor-programmable temperature switch with a temperature threshold that is set by just one external resistor within the entire operating range. The TMP709 provides an open-drain, active-low output and has a 2.7-V to 5.5-V supply-voltage range.

The temperature threshold accuracy is typically $\pm 0.5^{\circ}\text{C}$, with a maximum of $\pm 3^{\circ}\text{C}$ (60°C to 100°C). The quiescent current consumption is typically $40\ \mu\text{A}$. Hysteresis is pin-selectable to 2°C or 10°C .

The TMP709 is available in a 5-pin, SOT-23 package.

Device Information⁽¹⁾

| PART NUMBER | PACKAGE | BODY SIZE (NOM) |
|-------------|------------|-------------------|
| TMP709 | SOT-23 (5) | 2.90 mm x 1.60 mm |

(1) For all available packages, see the package option addendum at the end of the datasheet.

Typical Application

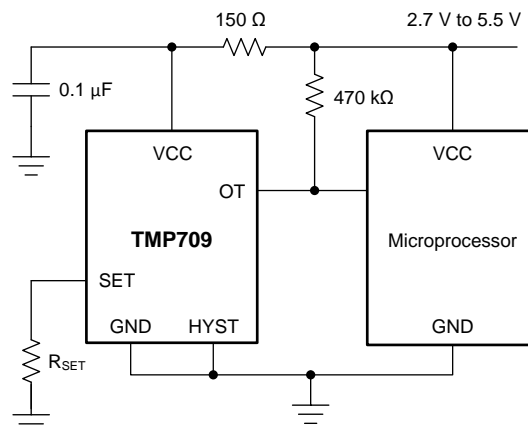

Copyright © 2016, Texas Instruments Incorporated



Table of Contents

| | |
|---|--|
| 1 Features 1 2 Applications 1 3 Description 1 4 Revision History 2 5 Pin Configuration and Functions 3 6 Specifications 4 6.1 Absolute Maximum Ratings 4 6.2 ESD Ratings..... 4 6.3 Recommended Operating Conditions 4 6.4 Thermal Information 4 6.5 Electrical Characteristics 5 6.6 Typical Characteristics 6 7 Detailed Description 7 7.1 Overview 7 7.2 Functional Block Diagram 7 7.3 Feature Description..... 8 | 7.4 Device Functional Modes..... 8 8 Applications and Implementation 9 8.1 Application Information..... 9 8.2 Typical Application 9 9 Power Supply Recommendations 11 10 Layout 11 10.1 Layout Guidelines 11 10.2 Layout Example 11 10.3 Thermal Considerations 11 11 Device and Documentation Support 12 11.1 Receiving Notification of Documentation Updates 12 11.2 Community Resources..... 12 11.3 Trademarks 12 11.4 Electrostatic Discharge Caution..... 12 11.5 Glossary 12 12 Mechanical, Packaging, and Orderable Information 12 |
|---|--|

4 Revision History

NOTE: Page numbers for previous revisions may differ from page numbers in the current version.

| Changes from Revision A (February 2012) to Revision B | Page |
|---|-------------|
| <ul style="list-style-type: none"> • Added <i>Device Information</i>, <i>ESD Ratings</i>, and <i>Recommended Operating Conditions</i> tables, and <i>Detailed Description</i>, <i>Application and Implementation</i>, <i>Power Supply Recommendations</i>, <i>Layout</i>, <i>Device and Documentation Support</i>, and <i>Mechanical, Packaging, and Orderable Information</i> sections..... | 1 |
| <ul style="list-style-type: none"> • Deleted <i>Package and Ordering Information</i> table; information now available in package option addendum located at the end of this data sheet | 2 |

| Changes from Original (December 2011) to Revision A | Page |
|---|-------------|
| <ul style="list-style-type: none"> • Updated threshold accuracy feature bullet | 1 |
| <ul style="list-style-type: none"> • Updated threshold accuracy text in second paragraph of <i>Description</i> section | 1 |
| <ul style="list-style-type: none"> • Updated temperature error parameter in the Electrical Characteristics | 5 |

5 Pin Configuration and Functions

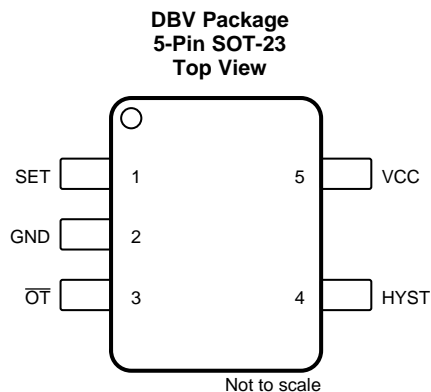

Pin Functions

| PIN | | TYPE | DESCRIPTION |
|-----------------|-----|----------------|---|
| NAME | NO. | | |
| GND | 2 | Analog power | Device ground |
| HYST | 4 | Digital input | Hysteresis selection. For 10°C, HYST = VCC; for 2°C, HYST = GND. |
| \overline{OT} | 3 | Digital output | Open-drain, active low output |
| SET | 1 | Analog input | Temperature set point. Connect an external 1% resistor between SET and GND. |
| VCC | 5 | Analog power | Power-supply voltage (2.7 V to 5.5 V) |

6 Specifications

6.1 Absolute Maximum Ratings

over operating free-air temperature range (unless otherwise noted)⁽¹⁾

| | | MIN | MAX | UNIT |
|-------------|---------------------------|------|-----------------------|------|
| Voltage | Supply, V _{CC} | -0.3 | 6 | V |
| | Input, SET and HYST | -0.3 | V _{CC} + 0.3 | |
| | Output, OT | -0.3 | 6 | |
| Current | Input | | 20 | mA |
| | Output | | 20 | |
| Temperature | Operating, T _A | -40 | 125 | °C |
| | Junction, T _J | | 150 | |
| | Storage, T _{stg} | -65 | 150 | |

- (1) Stresses beyond those listed under *Absolute Maximum Ratings* may cause permanent damage to the device. These are stress ratings only, which do not imply functional operation of the device at these or any other conditions beyond those indicated under *Recommended Operating Conditions*. Exposure to absolute-maximum-rated conditions for extended periods may affect device reliability.

6.2 ESD Ratings

| | | VALUE | UNIT |
|--------------------|--|-------|------|
| V _(ESD) | Electrostatic discharge | | V |
| | Human-body model (HBM), per ANSI/ESDA/JEDEC JS-001 ⁽¹⁾ | ±4000 | |
| | Charged-device model (CDM), per JEDEC specification JESD22-C101 ⁽²⁾ | ±1000 | |
| | Machine model (MM) | ±200 | |

- (1) JEDEC document JEP155 states that 500-V HBM allows safe manufacturing with a standard ESD control process.

- (2) JEDEC document JEP157 states that 250-V CDM allows safe manufacturing with a standard ESD control process.

6.3 Recommended Operating Conditions

over operating free-air temperature range (unless otherwise noted)

| | | MIN | NOM | MAX | UNIT |
|-----------------|-----------------------|-----|-----|-----|------|
| V _{CC} | Supply voltage | 2.7 | | 5.5 | V |
| T _A | Operating temperature | 0 | | 125 | °C |

6.4 Thermal Information

| THERMAL METRIC ⁽¹⁾ | | TMP709 | UNIT |
|-------------------------------|--|--------------|------|
| | | DBV (SOT-23) | |
| | | 5 PINS | |
| R _{θJA} | Junction-to-ambient thermal resistance | 217.9 | °C/W |
| R _{θJC(top)} | Junction-to-case (top) thermal resistance | 86.3 | °C/W |
| R _{θJB} | Junction-to-board thermal resistance | 44.6 | °C/W |
| ψ _{JT} | Junction-to-top characterization parameter | 4.4 | °C/W |
| ψ _{JB} | Junction-to-board characterization parameter | 43.8 | °C/W |
| R _{θJC(bot)} | Junction-to-case (bottom) thermal resistance | N/A | °C/W |

- (1) For more information about traditional and new thermal metrics, see the [Semiconductor and IC Package Thermal Metrics](#) application report.

6.5 Electrical Characteristics

 at $T_A = 0^\circ\text{C}$ to 125°C and $V_{CC} = 2.7\text{ V}$ to 5.5 V (unless otherwise noted)

| PARAMETER | | TEST CONDITIONS | MIN | TYP | MAX | UNIT |
|---|--------------------------|---|---------------------|-----------|---------------------|------------------|
| POWER SUPPLY | | | | | | |
| I_{CC} | Supply current | $V_{CC} = 5\text{ V}$ | | 40 | 55 | μA |
| | | $V_{CC} = 2.7\text{ V}$ | | 40 | 55 | μA |
| TEMPERATURE | | | | | | |
| T_E | Temperature error | $T_A = 60^\circ\text{C}$ to 100°C | | ± 0.5 | ± 3 | $^\circ\text{C}$ |
| DIGITAL INPUT (HYST) | | | | | | |
| V_{IH} | High-level input voltage | | $0.7 \times V_{CC}$ | | | V |
| V_{IL} | Low-level input voltage | | | | $0.3 \times V_{CC}$ | V |
| C_{IN} | Input capacitance | | | 10 | | pF |
| ANALOG INPUT (SET) | | | | | | |
| V_{IN} | Input voltage range | | 0 | | V_{CC} | V |
| I_{lk_in} | Input leakage current | | | 1 | | μA |
| DIGITAL OPEN-DRAIN OUTPUT (\overline{OT}) | | | | | | |
| $I_{(OT_SINK)}$ | Output sink current | $V_{OT} = 0.3\text{ V}$ | 5 | 12 | | mA |
| $I_{lk(OT)}$ | Output leakage current | $V_{OT} = V_{CC}$ | | 1 | | μA |

TMP709

SBOS583B – DECEMBER 2011 – REVISED DECEMBER 2016

www.ti.com

6.6 Typical Characteristics

at $T_A = 25^\circ\text{C}$ and $V_{CC} = 2.7\text{ V}$ to 5.5 V (unless otherwise noted)

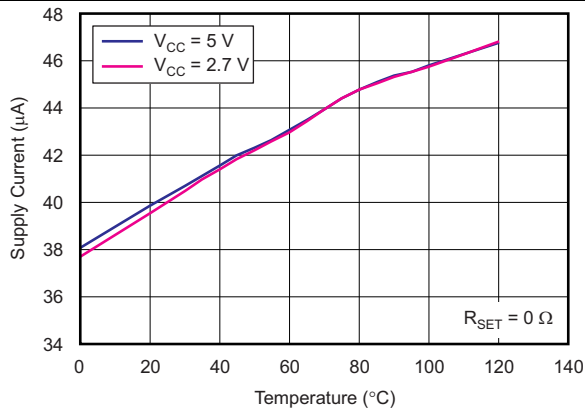

Figure 1. Supply Current vs Temperature

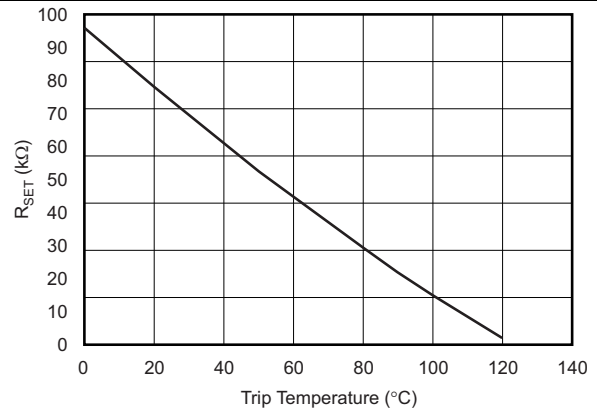

Figure 2. R_{SET} vs Trip Temperature

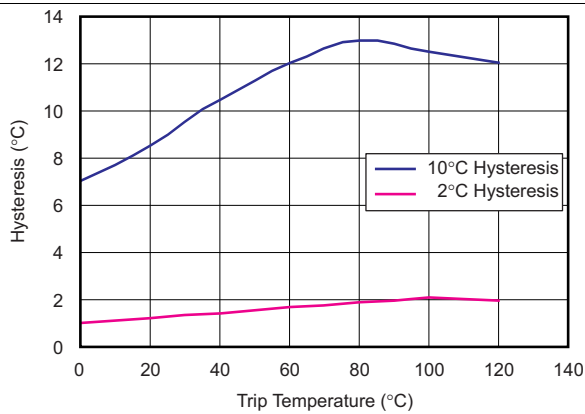

Figure 3. Hysteresis vs Trip Temperature

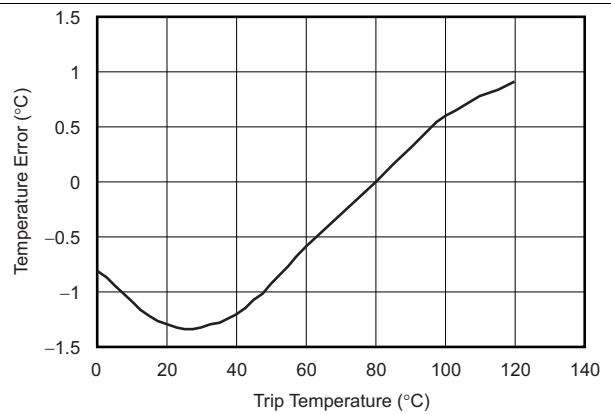

Figure 4. Temperature Error vs Trip Temperature

7 Detailed Description

7.1 Overview

The TMP709 is a fully-integrated, resistor-programmable temperature switch that incorporates two temperature-dependent voltage references and one comparator. One voltage reference exhibits a positive temperature coefficient (tempco), and the other voltage reference exhibits a negative tempco. The temperature at which both voltage references are equal determines the temperature trip point.

The [Functional Block Diagram](#) shows the comparator, the NFET open-drain device connected to the \overline{OT} pin, the positive tempco reference using the external R_{SET} resistor, the negative tempco reference, and the hysteresis control. The voltage of the positive tempco reference is controlled by external resistor R_{SET} .

7.2 Functional Block Diagram

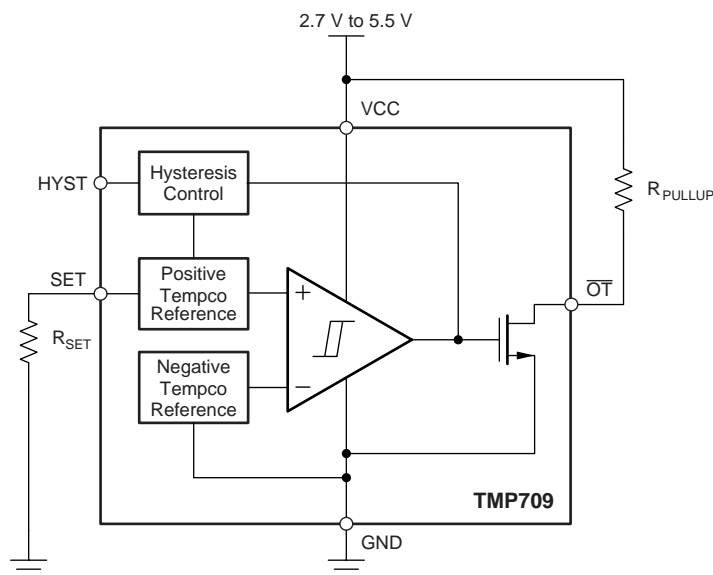

Copyright © 2016, Texas Instruments Incorporated

7.3 Feature Description

7.3.1 Temperature Switch

The TMP709 temperature threshold is programmable from 0°C to 125°C and is set by an external 1% resistor from the SET pin to the GND pin. The TMP709 has an open-drain, active-low output structure that easily interfaces with a microprocessor.

The TMP709 reaches the temperature trip point when the voltage from the positive tempco reference exceeds the voltage from the negative tempco reference. This difference causes the output of the comparator to switch from logic 0 to logic 1. The comparator output drives the gate of the NFET open-drain device, and pulls the voltage on the \overline{OT} pin from logic 1 to logic 0 under these conditions; in other words, the output *trips*. Furthermore, the logic 1 output from the comparator causes the hysteresis control to increase the voltage of the positive tempco reference by an amount set by the logic setting on the HYST pin (10°C for logic 1 on the HYST pin; 2°C for logic 0 on the HYST pin). Increase the voltage of the positive tempco reference after the TMP709 trips to stop the TMP709 from untripping (voltage on the \overline{OT} pin changing from logic 0 to logic 1) until the local temperature reduces by the amount set by the HYST pin. After the local temperature reduces, and the voltage from the positive tempco reference is less than the voltage from the negative tempco reference, the output of the comparator switches from logic 1 to logic 0. This condition causes the voltage on the \overline{OT} pin to change from logic 0 to logic 1 (device untrips).

7.3.2 Hysteresis Input

The HYST pin is a digital input that allows the input hysteresis to be set at either 10°C (when HYST = VCC) or 2°C (when HYST = GND). The hysteresis function keeps the \overline{OT} pin from oscillating when the temperature is near the threshold. Thus, always connect the HYST pin to either VCC or GND. Other input voltages on this pin can cause abnormal supply currents or a device malfunction.

7.3.3 Set-Point Resistor (R_{SET})

Set the temperature threshold by connecting R_{SET} from the SET pin to GND. The value of R_{SET} is determined using either [Figure 2](#) or [Equation 1](#):

$$R_{SET} \text{ (k}\Omega\text{)} = 0.0012T^2 - 0.9308T + 96.147$$

where

- T = temperature threshold in degrees Celsius. (1)

7.4 Device Functional Modes

The TMP709 device has a single functional mode. Normal operation for the TMP709 device occurs when the power-supply voltage applied across the VCC and GND pins is within the specified operating range of 2.7 V to 5.5 V.

8 Applications and Implementation

NOTE

Information in the following applications sections is not part of the TI component specification, and TI does not warrant its accuracy or completeness. TI's customers are responsible for determining suitability of components for their purposes. Customers should validate and test their design implementation to confirm system functionality.

8.1 Application Information

The TMP709 device is simple to configure. The only external components that the device requires are a bypass capacitor and pullup resistor. Power-supply bypassing is strongly recommended. Use a 0.1- μ F capacitor placed as close as possible to the VCC supply pin. To minimize the internal power dissipation of the TMP709 family of devices, use a pullup resistor value greater than 10 k Ω from the $\overline{\text{OT}}$ pin to the VCC pin. See the [Hysteresis Input](#) section for hysteresis configuration, and the [Set-Point Resistor \(\$R_{\text{SET}}\$ \)](#) section for configuring the temperature threshold.

8.2 Typical Application

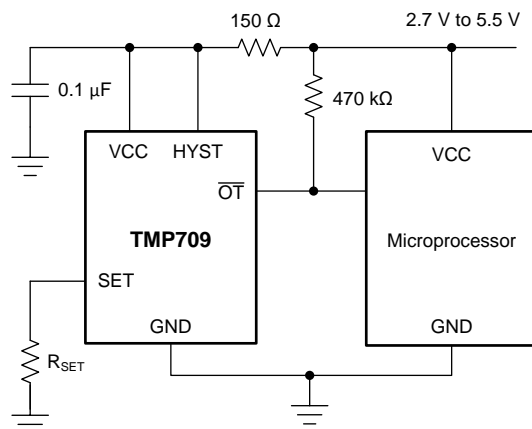

Copyright © 2016, Texas Instruments Incorporated

Figure 5. Overtemperature Protection for a 60°C Trip Point

8.2.1 Design Requirements

For this design example, a 2.7-V to 5.5-V power supply, 60°C trip point, and 10°C hysteresis are used.

Typical Application (continued)

8.2.2 Detailed Design Procedure

Connect the HYST pin to VCC for 10°C hysteresis. For a 60°C temperature threshold, see the [Set-Point Resistor \(\$R_{SET}\$ \)](#) section to compute an ideal R_{SET} resistor value of 44.619 k Ω . Select the closest standard value resistor available; in this case, 44.2 k Ω . Use a 10-k Ω pullup resistor from the \overline{OT} pin to the VCC pin. To minimize power, a larger-value pullup resistor can be used, but must not exceed 470 k Ω . Place a 0.1- μ F bypass capacitor close to the TMP709 device in order to reduce noise coupled from the power supply.

8.2.3 Application Curves

Figure 6 shows an example of the hysteresis feature. The HYST pin is connected to VCC, so the TMP709 device is configured for 10°C of hysteresis. The device is configured for a 60°C trip temperature by the R_{SET} resistor value; therefore, the \overline{OT} output asserts low when the 60°C threshold is exceeded. The \overline{OT} output remains asserted low until the sensor reaches 50°C.

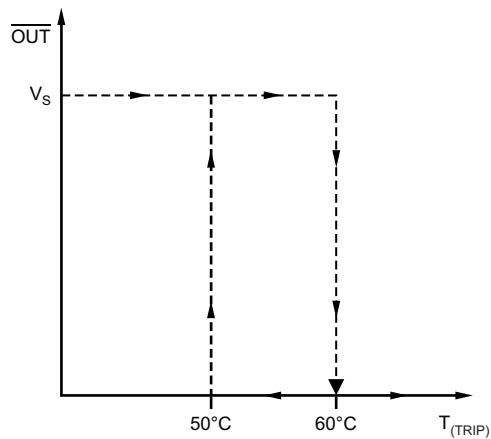

Figure 6. TMP709 Hysteresis Function

9 Power Supply Recommendations

The TMP709 low supply current and supply range allow this device to be powered from many sources. Any significant noise on the VCC pin can result in a trip-point error. Minimize this noise by low-pass filtering the device supply (V_{CC}) using a 150- Ω resistor and a 0.1- μ F capacitor.

10 Layout

10.1 Layout Guidelines

The TMP709 is extremely simple to lay out. [Figure 7](#) shows the recommended board layout.

10.2 Layout Example

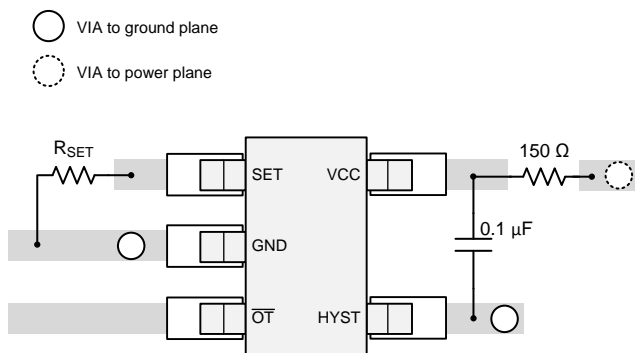

Figure 7. Recommended Layout

10.3 Thermal Considerations

The TMP709 quiescent current is typically 40 μ A. The device dissipates negligible power when the output drives a high-impedance load. Thus, the die temperature is the same as the package temperature. In order to maintain accurate temperature monitoring, provide a good thermal contact between the TMP709 package and the device being monitored. The rise in die temperature as a result of self-heating is given by [Equation 2](#):

$$\Delta T_J = P_{DISS} \times \theta_{JA}$$

where

- P_{DISS} = power dissipated by the device.
- θ_{JA} = package thermal resistance. Typical thermal resistance for SOT-23 package is 217.9°C/W. (2)

To limit the effects of self-heating, keep the output current at a minimum level.

11 Device and Documentation Support

11.1 Receiving Notification of Documentation Updates

To receive notification of documentation updates, navigate to the device product folder on ti.com. In the upper right corner, click on *Alert me* to register and receive a weekly digest of any product information that has changed. For change details, review the revision history included in any revised document.

11.2 Community Resources

The following links connect to TI community resources. Linked contents are provided "AS IS" by the respective contributors. They do not constitute TI specifications and do not necessarily reflect TI's views; see TI's [Terms of Use](#).

TI E2E™ Online Community *TI's Engineer-to-Engineer (E2E) Community*. Created to foster collaboration among engineers. At e2e.ti.com, you can ask questions, share knowledge, explore ideas and help solve problems with fellow engineers.

Design Support *TI's Design Support* Quickly find helpful E2E forums along with design support tools and contact information for technical support.

11.3 Trademarks

E2E is a trademark of Texas Instruments.
All other trademarks are the property of their respective owners.

11.4 Electrostatic Discharge Caution



This integrated circuit can be damaged by ESD. Texas Instruments recommends that all integrated circuits be handled with appropriate precautions. Failure to observe proper handling and installation procedures can cause damage.

ESD damage can range from subtle performance degradation to complete device failure. Precision integrated circuits may be more susceptible to damage because very small parametric changes could cause the device not to meet its published specifications.

11.5 Glossary

[SLYZ022](#) — *TI Glossary*.

This glossary lists and explains terms, acronyms, and definitions.

12 Mechanical, Packaging, and Orderable Information

The following pages include mechanical, packaging, and orderable information. This information is the most current data available for the designated devices. This data is subject to change without notice and revision of this document. For browser-based versions of this data sheet, refer to the left-hand navigation.

PACKAGING INFORMATION

| Orderable Device | Status (1) | Package Type | Package Drawing | Pins | Package Qty | Eco Plan (2) | Lead/Ball Finish (6) | MSL Peak Temp (3) | Op Temp (°C) | Device Marking (4/5) | Samples |
|------------------|---------------|--------------|-----------------|------|-------------|-------------------------|-------------------------|----------------------|--------------|-------------------------|-------------------------|
| TMP709AIDBVR | ACTIVE | SOT-23 | DBV | 5 | 3000 | Green (RoHS & no Sb/Br) | CU NIPDAU | Level-2-260C-1 YEAR | -40 to 125 | SBJ | Samples |
| TMP709AIDBVT | ACTIVE | SOT-23 | DBV | 5 | 250 | Green (RoHS & no Sb/Br) | CU NIPDAU | Level-2-260C-1 YEAR | -40 to 125 | SBJ | Samples |

(1) The marketing status values are defined as follows:

ACTIVE: Product device recommended for new designs.

LIFEBUY: TI has announced that the device will be discontinued, and a lifetime-buy period is in effect.

NRND: Not recommended for new designs. Device is in production to support existing customers, but TI does not recommend using this part in a new design.

PREVIEW: Device has been announced but is not in production. Samples may or may not be available.

OBSOLETE: TI has discontinued the production of the device.

(2) Eco Plan - The planned eco-friendly classification: Pb-Free (RoHS), Pb-Free (RoHS Exempt), or Green (RoHS & no Sb/Br) - please check <http://www.ti.com/productcontent> for the latest availability information and additional product content details.

TBD: The Pb-Free/Green conversion plan has not been defined.

Pb-Free (RoHS): TI's terms "Lead-Free" or "Pb-Free" mean semiconductor products that are compatible with the current RoHS requirements for all 6 substances, including the requirement that lead not exceed 0.1% by weight in homogeneous materials. Where designed to be soldered at high temperatures, TI Pb-Free products are suitable for use in specified lead-free processes.

Pb-Free (RoHS Exempt): This component has a RoHS exemption for either 1) lead-based flip-chip solder bumps used between the die and package, or 2) lead-based die adhesive used between the die and leadframe. The component is otherwise considered Pb-Free (RoHS compatible) as defined above.

Green (RoHS & no Sb/Br): TI defines "Green" to mean Pb-Free (RoHS compatible), and free of Bromine (Br) and Antimony (Sb) based flame retardants (Br or Sb do not exceed 0.1% by weight in homogeneous material)

(3) MSL, Peak Temp. - The Moisture Sensitivity Level rating according to the JEDEC industry standard classifications, and peak solder temperature.

(4) There may be additional marking, which relates to the logo, the lot trace code information, or the environmental category on the device.

(5) Multiple Device Markings will be inside parentheses. Only one Device Marking contained in parentheses and separated by a "~" will appear on a device. If a line is indented then it is a continuation of the previous line and the two combined represent the entire Device Marking for that device.

(6) Lead/Ball Finish - Orderable Devices may have multiple material finish options. Finish options are separated by a vertical ruled line. Lead/Ball Finish values may wrap to two lines if the finish value exceeds the maximum column width.

Important Information and Disclaimer: The information provided on this page represents TI's knowledge and belief as of the date that it is provided. TI bases its knowledge and belief on information provided by third parties, and makes no representation or warranty as to the accuracy of such information. Efforts are underway to better integrate information from third parties. TI has taken and continues to take reasonable steps to provide representative and accurate information but may not have conducted destructive testing or chemical analysis on incoming materials and chemicals. TI and TI suppliers consider certain information to be proprietary, and thus CAS numbers and other limited information may not be available for release.

In no event shall TI's liability arising out of such information exceed the total purchase price of the TI part(s) at issue in this document sold by TI to Customer on an annual basis.

TAPE AND REEL INFORMATION

QUADRANT ASSIGNMENTS FOR PIN 1 ORIENTATION IN TAPE

*All dimensions are nominal

| Device | Package Type | Package Drawing | Pins | SPQ | Reel Diameter (mm) | Reel Width W1 (mm) | A0 (mm) | B0 (mm) | K0 (mm) | P1 (mm) | W (mm) | Pin1 Quadrant |
|--------------|--------------|-----------------|------|------|--------------------|--------------------|---------|---------|---------|---------|--------|---------------|
| TMP709AIDBVR | SOT-23 | DBV | 5 | 3000 | 178.0 | 9.0 | 3.3 | 3.2 | 1.4 | 4.0 | 8.0 | Q3 |
| TMP709AIDBVT | SOT-23 | DBV | 5 | 250 | 178.0 | 9.0 | 3.3 | 3.2 | 1.4 | 4.0 | 8.0 | Q3 |

TAPE AND REEL BOX DIMENSIONS

*All dimensions are nominal

| Device | Package Type | Package Drawing | Pins | SPQ | Length (mm) | Width (mm) | Height (mm) |
|--------------|--------------|-----------------|------|------|-------------|------------|-------------|
| TMP709AIDBVR | SOT-23 | DBV | 5 | 3000 | 180.0 | 180.0 | 18.0 |
| TMP709AIDBVT | SOT-23 | DBV | 5 | 250 | 180.0 | 180.0 | 18.0 |

EXAMPLE BOARD LAYOUT

DBV0005A

SOT-23 - 1.45 mm max height

SMALL OUTLINE TRANSISTOR



LAND PATTERN EXAMPLE
EXPOSED METAL SHOWN
SCALE:15X



SOLDER MASK DETAILS

4214839/D 11/2018

NOTES: (continued)

- 5. Publication IPC-7351 may have alternate designs.
- 6. Solder mask tolerances between and around signal pads can vary based on board fabrication site.

EXAMPLE STENCIL DESIGN

DBV0005A

SOT-23 - 1.45 mm max height

SMALL OUTLINE TRANSISTOR



SOLDER PASTE EXAMPLE
BASED ON 0.125 mm THICK STENCIL
SCALE:15X

4214839/D 11/2018

NOTES: (continued)

7. Laser cutting apertures with trapezoidal walls and rounded corners may offer better paste release. IPC-7525 may have alternate design recommendations.
8. Board assembly site may have different recommendations for stencil design.

IMPORTANT NOTICE AND DISCLAIMER

TI PROVIDES TECHNICAL AND RELIABILITY DATA (INCLUDING DATASHEETS), DESIGN RESOURCES (INCLUDING REFERENCE DESIGNS), APPLICATION OR OTHER DESIGN ADVICE, WEB TOOLS, SAFETY INFORMATION, AND OTHER RESOURCES "AS IS" AND WITH ALL FAULTS, AND DISCLAIMS ALL WARRANTIES, EXPRESS AND IMPLIED, INCLUDING WITHOUT LIMITATION ANY IMPLIED WARRANTIES OF MERCHANTABILITY, FITNESS FOR A PARTICULAR PURPOSE OR NON-INFRINGEMENT OF THIRD PARTY INTELLECTUAL PROPERTY RIGHTS.

These resources are intended for skilled developers designing with TI products. You are solely responsible for (1) selecting the appropriate TI products for your application, (2) designing, validating and testing your application, and (3) ensuring your application meets applicable standards, and any other safety, security, or other requirements. These resources are subject to change without notice. TI grants you permission to use these resources only for development of an application that uses the TI products described in the resource. Other reproduction and display of these resources is prohibited. No license is granted to any other TI intellectual property right or to any third party intellectual property right. TI disclaims responsibility for, and you will fully indemnify TI and its representatives against, any claims, damages, costs, losses, and liabilities arising out of your use of these resources.

TI's products are provided subject to TI's Terms of Sale (www.ti.com/legal/termsofsale.html) or other applicable terms available either on ti.com or provided in conjunction with such TI products. TI's provision of these resources does not expand or otherwise alter TI's applicable warranties or warranty disclaimers for TI products.

Mailing Address: Texas Instruments, Post Office Box 655303, Dallas, Texas 75265
Copyright © 2019, Texas Instruments Incorporated

Looking for pricing, stock, or lifecycle information?

Click below to explore more details on WIN SOURCE:

 [View TMP709AIDBVR on WIN SOURCE](#)

 [Texas Instruments](#) Information

Optimize Your Supply Chain with WIN SOURCE Solutions

-  Global Sourcing Solution
-  Obsolete Management
-  Cost Control Management
-  Shortage Management
-  Alternative Solution
-  Excess Inventory Management