



**THE DATASHEET OF  
LMH0302SQ/NOPB**



## LMH0302 3-Gbps HD/SD SDI Cable Driver

### 1 Features

- Supports ST 424 (3G), 292 (HD), and 259 (SD)
- Data Rates up to 2.97 Gbps
- Supports DVB-ASI at 270 Mbps
- 100-Ω Differential Input
- 75-Ω Single-Ended Outputs
- Selectable Slew Rate
- Output Driver Power-Down Control
- Single 3.3-V Supply Operation
- Industrial Temperature Range:  $-40^{\circ}\text{C}$  to  $85^{\circ}\text{C}$
- Typical Power Consumption: 125 mW in SD Mode and 165 mW in HD Mode
- 16-Pin WQFN Package
- Footprint Compatible With the LMH0002SQ
- Replaces the Gennum GS2978

### 2 Applications

- ST 424, ST 292, ST 344, and ST 259 Serial Digital Interfaces
- Digital Video Routers and Switches
- Distribution Amplifiers

### 3 Description

The LMH0302 3-Gbps HD/SD SDI cable driver is designed for use in ST 424, ST 292, ST 344, and ST 259 serial digital video applications. The LMH0302 drives 75-Ω transmission lines (Belden 1694A, Belden 8281, or equivalent) at data rates up to 2.97 Gbps.

The LMH0302 provides two selectable slew rates for ST 259 and ST 424 or 292 compliance. The output driver may be powered down through the output driver enable pin.

The LMH0302 is powered from a single 3.3-V supply. Power consumption is typically 125 mW in SD mode and 165 mW in HD mode. The LMH0302 is available in a 16-pin WQFN package.

#### Device Information<sup>(1)</sup>

PART NUMBER	PACKAGE	BODY SIZE (NOM)
LMH0302	WQFN (16)	4.00 mm × 4.00 mm

(1) For all available packages, see the orderable addendum at the end of the data sheet.

#### Typical Application

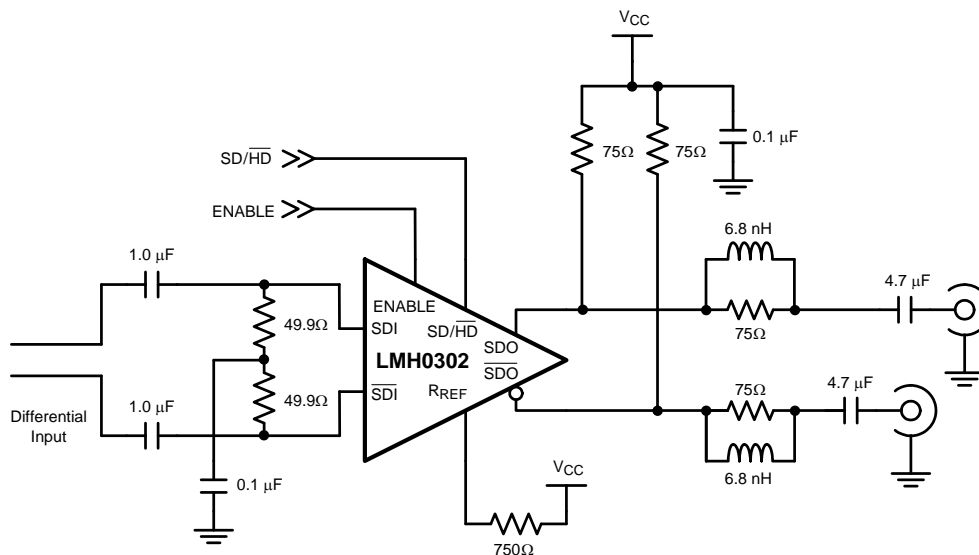

Copyright © 2016, Texas Instruments Incorporated



## Table of Contents

<b>1 Features</b> ..... 1 <b>2 Applications</b> ..... 1 <b>3 Description</b> ..... 1 <b>4 Revision History</b> ..... 2 <b>5 Pin Configuration and Functions</b> ..... 3 <b>6 Specifications</b> ..... 4 6.1 Absolute Maximum Ratings ..... 4 6.2 ESD Ratings..... 4 6.3 Recommended Operating Conditions ..... 4 6.4 Thermal Information ..... 4 6.5 Electrical Characteristics – DC ..... 4 6.6 Electrical Characteristics – AC..... 5 6.7 Typical Characteristics ..... 5 <b>7 Detailed Description</b> ..... 6 7.1 Overview ..... 6 7.2 Functional Block Diagram ..... 6	7.3 Feature Description ..... 6 7.4 Device Functional Modes..... 7 <b>8 Application and Implementation</b> ..... 8 8.1 Application Information ..... 8 8.2 Typical Application ..... 8 <b>9 Power Supply Recommendations</b> ..... 10 <b>10 Layout</b> ..... 10 10.1 Layout Guidelines ..... 10 10.2 Layout Example ..... 11 <b>11 Device and Documentation Support</b> ..... 12 11.1 Community Resources..... 12 11.2 Trademarks ..... 12 11.3 Electrostatic Discharge Caution..... 12 11.4 Glossary ..... 12 <b>12 Mechanical, Packaging, and Orderable Information</b> ..... 12
--------------------------------------------------------------------------------------------------------------------------------------------------------------------------------------------------------------------------------------------------------------------------------------------------------------------------------------------------------------------------------------------------------------------------------------------------------------------------------------------------------------------------------------------------------------------------------------------------------------------------	------------------------------------------------------------------------------------------------------------------------------------------------------------------------------------------------------------------------------------------------------------------------------------------------------------------------------------------------------------------------------------------------------------------------------------------------------------------------------------------------------------------------------------------------------------------------------------------------------------------------------

## 4 Revision History

NOTE: Page numbers for previous revisions may differ from page numbers in the current version.

### Changes from Revision G (April 2013) to Revision H

**Page**

- Added *ESD Ratings* table, *Feature Description* section, *Device Functional Modes*, *Application and Implementation* section, *Power Supply Recommendations* section, *Layout* section, *Device and Documentation Support* section, and *Mechanical, Packaging, and Orderable Information* section ..... 1

### Changes from Revision F (April 2013) to Revision G

**Page**

- Changed layout of National Data Sheet to TI format ..... 1

## 5 Pin Configuration and Functions

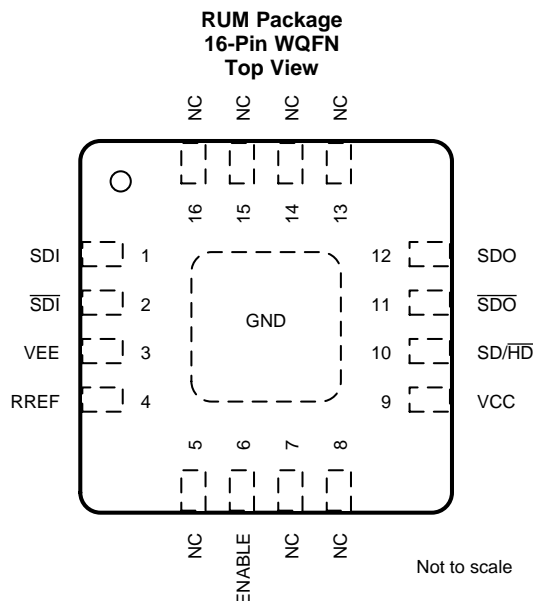

### Pin Functions

PIN		TYPE <sup>(1)</sup>	DESCRIPTION
NAME	NO.		
ENABLE	6	I	Output driver enable. When low, the SDO/ $\overline{\text{SDO}}$ output driver is powered off. ENABLE has an internal pullup. H = Normal operation. L = Output driver powered off.
EP	—	G	EP is the exposed pad at the bottom of the WQFN package. The exposed pad must be connected to the ground plane through a via array. See <a href="#">Figure 6</a> for details.
NC	5, 7, 8, 13, 14, 15, 16	—	No connect. Not bonded internally.
$R_{\text{REF}}$	4	I	Output driver level control. Connect a resistor to $V_{\text{CC}}$ to set output voltage swing.
$\text{SD}/\overline{\text{HD}}$	10	I	Output slew rate control. Output rise/fall time complies with ST 424 or 292 when low and ST 259 when high.
SDI	1	I	Serial data true input.
$\overline{\text{SDI}}$	2	I	Serial data complement input.
SDO	12	O	Serial data true output.
$\overline{\text{SDO}}$	11	O	Serial data complement output.
$V_{\text{CC}}$	9	P	Positive power supply (3.3 V).
$V_{\text{EE}}$	3	G	Negative power supply (ground).

(1) G = Ground, I = Input, O = Output, and P = Power

## 6 Specifications

### 6.1 Absolute Maximum Ratings

over operating free-air temperature range (unless otherwise noted)<sup>(1)</sup>

	MIN	MAX	UNIT
Supply voltage	-0.5	3.6	V
Input voltage (all inputs)	-0.3	$V_{CC} + 0.3$	V
Output current		28	mA
Lead temperature, soldering (4 s)		260	°C
Junction temperature, $T_J$		125	°C
Storage temperature, $T_{stg}$	-65	150	°C

- (1) Stresses beyond those listed under *Absolute Maximum Ratings* may cause permanent damage to the device. These are stress ratings only, which do not imply functional operation of the device at these or any other conditions beyond those indicated under *Recommended Operating Conditions*. Exposure to absolute-maximum-rated conditions for extended periods may affect device reliability.

### 6.2 ESD Ratings

		VALUE	UNIT
$V_{(ESD)}$ Electrostatic discharge	Human-body model (HBM), per ANSI/ESDA/JEDEC JS-001 <sup>(1)</sup>	±4500	V
	Charged-device model (CDM), per JEDEC specification JESD22-C101 <sup>(2)</sup>	±2000	
	Machine model (MM)	±250	

- (1) JEDEC document JEP155 states that 500-V HBM allows safe manufacturing with a standard ESD control process.  
 (2) JEDEC document JEP157 states that 250-V CDM allows safe manufacturing with a standard ESD control process.

### 6.3 Recommended Operating Conditions

over operating free-air temperature range (unless otherwise noted)

	MIN	NOM	MAX	UNIT
Supply voltage ( $V_{CC} - V_{EE}$ )	3.13	3.3	3.46	V
Operating junction temperature			100	°C
Operating free air temperature, $T_A$	-40	25	85	°C

### 6.4 Thermal Information

THERMAL METRIC <sup>(1)</sup>		LMH0302	UNIT
		RUM (WQFN)	
		16 PINS	
$R_{\theta JA}$	Junction-to-ambient thermal resistance	47.8	°C/W
$R_{\theta JC(top)}$	Junction-to-case (top) thermal resistance	47.2	°C/W
$R_{\theta JB}$	Junction-to-board thermal resistance	25.6	°C/W
$\Psi_{JT}$	Junction-to-top characterization parameter	1.7	°C/W
$\Psi_{JB}$	Junction-to-board characterization parameter	25.7	°C/W
$R_{\theta JC(bot)}$	Junction-to-case (bottom) thermal resistance	14.5	°C/W

- (1) For more information about traditional and new thermal metrics, see the *Semiconductor and IC Package Thermal Metrics* application report, [SPRA953](#).

### 6.5 Electrical Characteristics – DC

Over supply voltage and operating free-air temperature range (unless otherwise noted)<sup>(1)(2)</sup>

PARAMETER	TEST CONDITIONS	MIN	TYP	MAX	UNIT
$V_{CMIN}$ Input common mode voltage	SDI, $\overline{SDI}$	$1.1 + V_{SDI}/2$		$V_{CC} - V_{SDI}/2$	V
$V_{SDI}$ Input voltage swing	Differential, SDI, $\overline{SDI}$	100		2200	mV <sub>P-P</sub>

- (1) Current flow into device pins is defined as positive. Current flow out of device pins is defined as negative. All voltages are stated referenced to  $V_{EE} = 0$  V.  
 (2) Typical values are stated for  $V_{CC} = 3.3$  V and  $T_A = 25^\circ\text{C}$ .

## Electrical Characteristics – DC (continued)

Over supply voltage and operating free-air temperature range (unless otherwise noted) <sup>(1)(2)</sup>

PARAMETER	TEST CONDITIONS	MIN	TYP	MAX	UNIT
V <sub>CMOUT</sub>	Output common mode voltage	V <sub>CC</sub> – V <sub>SDO</sub>			V
V <sub>SDO</sub>	Output voltage swing	720	800	880	mV <sub>P-P</sub>
V <sub>IH</sub>	Input voltage high level	SD/ $\overline{\text{HD}}$ , ENABLE			V
V <sub>IL</sub>	Input voltage low level	SD/ $\overline{\text{HD}}$ , ENABLE			V
I <sub>CC</sub>	Supply current	SD/ $\overline{\text{HD}}$ = 0, SDO/ $\overline{\text{SDO}}$ enabled		50	59
		SD/ $\overline{\text{HD}}$ = 0, SDO/ $\overline{\text{SDO}}$ disabled		26	33
		SD/ $\overline{\text{HD}}$ = 1, SDO/ $\overline{\text{SDO}}$ enabled		38	48
		SD/ $\overline{\text{HD}}$ = 1, SDO/ $\overline{\text{SDO}}$ disabled		15	22

## 6.6 Electrical Characteristics – AC

Over supply voltage and operating free-air temperature range (unless otherwise noted) <sup>(1)</sup>

PARAMETER	TEST CONDITIONS	MIN	TYP	MAX	UNIT	
DR <sub>SDI</sub>	Input data rate	SDI, $\overline{\text{SDI}}$			2970	Mbps
T <sub>jit</sub>	Additive jitter	2.97 Gbps, SDO, $\overline{\text{SDO}}$		20	pSP-P	
		1.485 Gbps, SDO, $\overline{\text{SDO}}$		18		
		270 Mbps, SDO, $\overline{\text{SDO}}$		15		
t <sub>r</sub> , t <sub>f</sub>	Output rise time, fall time	SD/ $\overline{\text{HD}}$ = 0, 20% – 80%, SDO, $\overline{\text{SDO}}$		90	130	ps
		SD/ $\overline{\text{HD}}$ = 1, 20% – 80%, SDO, $\overline{\text{SDO}}$		400	800	
T <sub>MATCH</sub>	Mismatch in rise time, fall time	SD/ $\overline{\text{HD}}$ = 0, SDO, $\overline{\text{SDO}}$		30		ps
		SD/ $\overline{\text{HD}}$ = 1, SDO, $\overline{\text{SDO}}$		50		
T <sub>DCCD</sub>	Duty cycle distortion	SD/ $\overline{\text{HD}}$ = 0, 2.97 Gbps, SDO, $\overline{\text{SDO}}$ <sup>(2)</sup>		27		ps
		SD/ $\overline{\text{HD}}$ = 0, 1.485 Gbps, SDO, $\overline{\text{SDO}}$ <sup>(2)</sup>		30		
		SD/ $\overline{\text{HD}}$ = 1, SDO, $\overline{\text{SDO}}$ <sup>(2)</sup>		100		
T <sub>OS</sub>	Output overshoot	SD/ $\overline{\text{HD}}$ = 0, SDO, $\overline{\text{SDO}}$ <sup>(2)</sup>		10%		
		SD/ $\overline{\text{HD}}$ = 1, SDO, $\overline{\text{SDO}}$ <sup>(2)</sup>		8%		
RL <sub>SDO</sub>	Output return loss	5 MHz to 1.5 GHz, SDO, $\overline{\text{SDO}}$ <sup>(3)</sup>		15		dB
		1.5 GHz to 3.0 GHz, SDO, $\overline{\text{SDO}}$ <sup>(3)</sup>		10		

(1) Typical values are stated for V<sub>CC</sub> = 3.3 V and T<sub>A</sub> = 25°C.

(2) Specification is ensured by characterization.

(3) Output return loss is dependent on board design. The LMH0302 meets this specification on the SD302 evaluation board.

## 6.7 Typical Characteristics

Typical device characteristics at T<sub>A</sub> = 25°C and V<sub>CC</sub> = 3.3 V (unless otherwise noted)

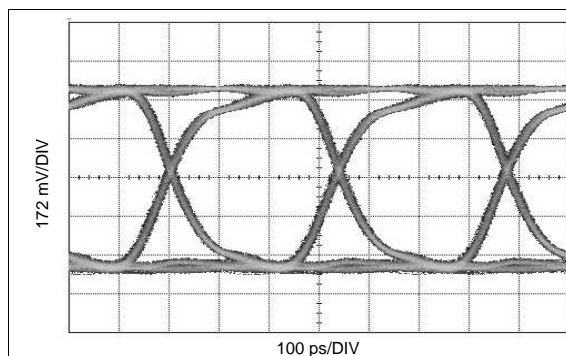

Figure 1. SDO PRBS10 at 2.97 Gbps

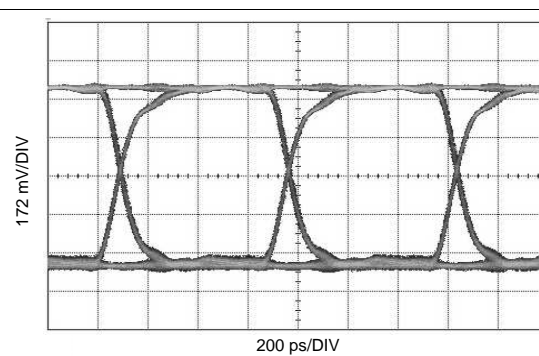

Figure 2. SDO PRBS10 at 1.485 Gbps

## 7 Detailed Description

### 7.1 Overview

The LMH0302 ST 424, ST292, ST259 serial digital cable driver is a monolithic, high-speed cable driver designed for use in serial digital video data transmission applications. The LMH0302 drives 75- $\Omega$  transmission lines (Belden 8281, 1694A, Canare L-5CFB, or equivalent) at data rates up to 2.97 Gbps.

The LMH0302 provides two selectable slew rates for ST 259 and ST 292/424 compliance. The output voltage swing is adjustable through a single external resistor ( $R_{REF}$ ).

The LMH0302 is powered from a single 3.3-V supply. Power consumption is typically 125 mW in SD mode and 165 mW in HD mode. The LMH0302 is available in a 16-pin WQFN package.

### 7.2 Functional Block Diagram

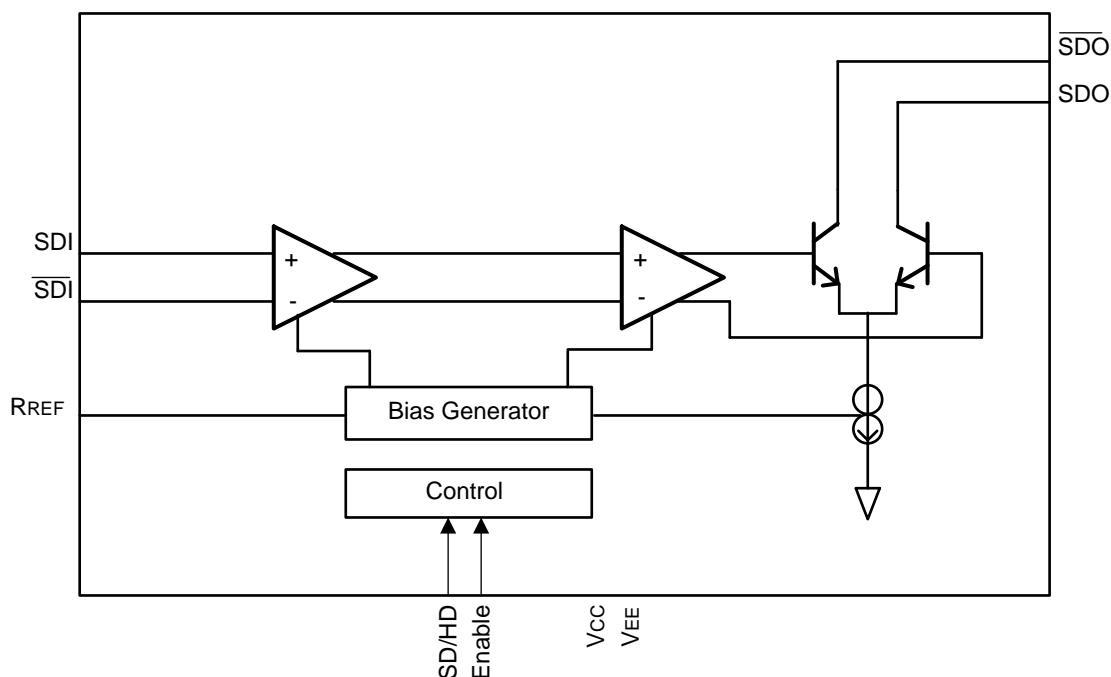

Copyright © 2016, Texas Instruments Incorporated

### 7.3 Feature Description

The LMH0302 data path consists of several key blocks:

- Input interfacing
- Output interfacing
- Output slew rate control
- Output enable

#### 7.3.1 Input Interfacing

The LMH0302 accepts either differential or single-ended input. The inputs are self-biased, allowing for simple AC or DC coupling. DC-coupled inputs must be kept within the specified common-mode range.

#### 7.3.2 Output Interfacing

The LMH0302 uses current mode outputs. Single-ended output levels are 800 mV<sub>P-P</sub> into 75- $\Omega$  AC-coupled coaxial cable with an  $R_{REF}$  resistor of 750  $\Omega$ . The  $R_{REF}$  resistor is connected between the  $R_{REF}$  pin and  $V_{CC}$ .

## Feature Description (continued)

The  $R_{REF}$  resistor must be placed as close as possible to the  $R_{REF}$  pin. In addition, the copper in the plane layers below the  $R_{REF}$  network must be removed to minimize parasitic capacitance.

### 7.3.3 Output Slew Rate Control

The LMH0302 output rise and fall times are selectable for either ST 259, ST 424, or 292 compliance through the  $\overline{SD/HD}$  pin. For slower rise and fall times, or ST 259 compliance,  $\overline{SD/HD}$  is set high. For faster rise and fall times, ST 424 and ST 292 compliance,  $\overline{SD/HD}$  is set low.

### 7.3.4 Output Enable

The  $\overline{SDO/SDO}$  output driver are enabled or disabled with the ENABLE pin. When set low, the output driver is powered off. ENABLE has an internal pullup.

## 7.4 Device Functional Modes

The LMH0302 features are programmed using pin mode only.

## 8 Application and Implementation

### NOTE

Information in the following applications sections is not part of the TI component specification, and TI does not warrant its accuracy or completeness. TI's customers are responsible for determining suitability of components for their purposes. Customers should validate and test their design implementation to confirm system functionality.

### 8.1 Application Information

The LMH0302 is a single-channel SDI cable driver that supports different application spaces. The following sections describe the typical use cases and common implementation practices.

#### 8.1.1 General Guidance for All Applications

The SMPTE specifications define the use of AC-coupling capacitors for transporting uncompressed serial data streams with heavy low-frequency content. This specification requires the use of a 4.7- $\mu\text{F}$  AC-coupling capacitor to avoid low frequency DC wander. The 75- $\Omega$  signal is also required to meet certain rise and fall timing to facilitate highest eye opening for the receiving device.

SMPTE specifies the requirements for the Serial Digital Interface to transport digital video at SD, HD, 3 Gbps, and higher data rates over coaxial cables. One of the requirements is meeting the required return loss. This requirement specifies how closely the port resembles 75- $\Omega$  impedance across a specified frequency band. Output return loss is dependent on board design. The LMH0302 supports these requirements.

### 8.2 Typical Application

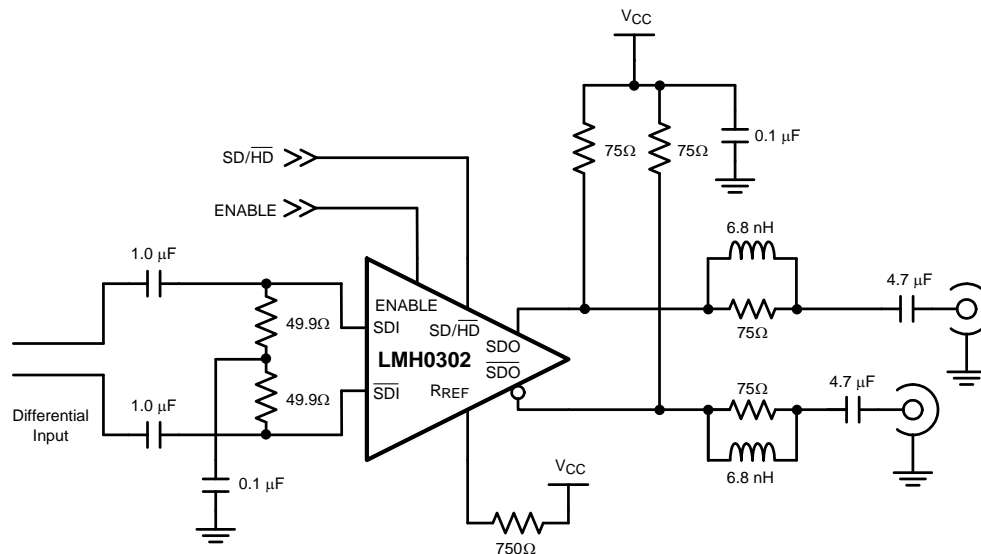

Copyright © 2016, Texas Instruments Incorporated

**Figure 3. Application Circuit**

## Typical Application (continued)

### 8.2.1 Design Requirements

For the LMH0302 design example, [Table 1](#) lists the design parameters.

**Table 1. LMH0302 Design Parameters**

PARAMETER	REQUIREMENT
Input termination	Required; 49.9 $\Omega$ are recommended (see <a href="#">Figure 3</a> ).
Output AC-coupling capacitors	Required; both SDO and $\overline{\text{SDO}}$ require AC-coupling capacitors. SDO AC-coupling capacitors are expected to be 4.7 $\mu\text{F}$ to comply with SMPTE wander requirement.
DC power supply coupling capacitors	To minimize power supply noise, place 0.1- $\mu\text{F}$ capacitor as close to the device $V_{\text{CC}}$ pin as possible.
Distance from device to BNC	Keep this distance as short as possible.
High speed SDI and $\overline{\text{SDI}}$ trace impedance	Design differential trace impedance of SDI and $\overline{\text{SDI}}$ with 100 $\Omega$ .
High speed SDO and $\overline{\text{SDO}}$ trace impedance	Single-ended trace impedance for SDO and $\overline{\text{SDO}}$ with 75 $\Omega$ .

### 8.2.2 Detailed Design Procedure

The following design procedure is recommended:

1. Select a suitable power supply voltage for the LMH0302. It can be powered from a single 3.3-V supply.
2. Check that the power supply meets the DC requirements in [Electrical Characteristics – DC](#).
3. Select the proper pull-high or pull-low for SD/ $\overline{\text{HD}}$  to set the slew rate.
4. Select proper pull-high or pull-low for ENABLE to enable or disable the output driver.
5. Choose a high-quality 75- $\Omega$  BNC that is capable to support 2.97-Gbps applications. Consult a BNC supplier regarding insertion loss, impedance specifications, and recommended BNC footprint for meeting SMPTE return loss requirements.
6. Choose small 0402 surface-mount ceramic capacitors for the AC-coupling and bypass capacitors.
7. Use proper footprint for BNC and AC-coupling capacitors. Anti-pads are commonly used in power and ground planes under these landing pads to achieve optimum return loss.

### 8.2.3 Application Curves

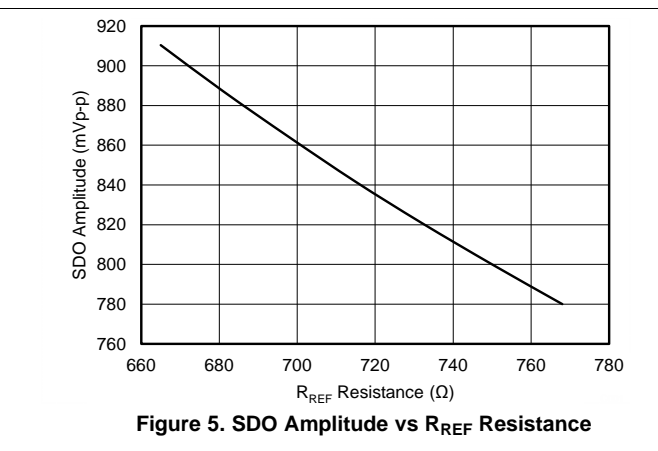
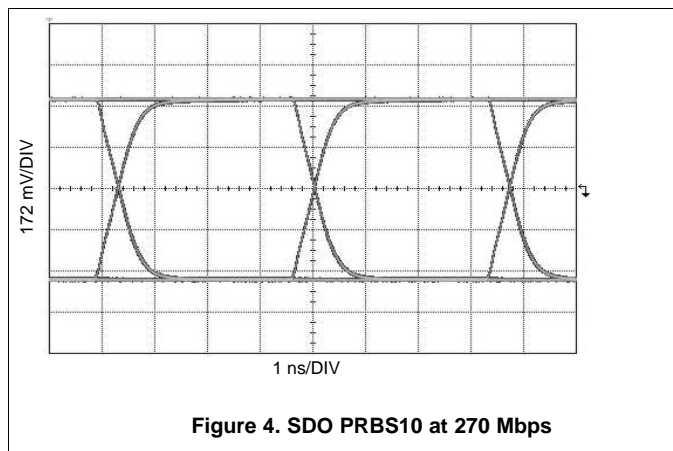

## 9 Power Supply Recommendations

Follow these general guidelines when designing the power supply:

1. The power supply must be designed to provide the recommended operating conditions (see [Recommended Operating Conditions](#)).
2. The maximum current draw for the LMH0302 is provided in [Electrical Characteristics – DC](#). This figure can be used to calculate the maximum current the supply must provide.
3. The LMH0302 does not require any special power supply filtering, provided the recommended operating conditions are met. Only standard supply coupling is required.

## 10 Layout

### 10.1 Layout Guidelines

TI recommends the following layout guidelines for the LMH0302:

1. The  $R_{REF}$  1% tolerance resistor must be placed as close as possible to the  $R_{REF}$  pin. In addition, the copper in the plane layers below the  $R_{REF}$  network must be removed to minimize parasitic capacitance.
2. Choose a suitable board stackup that supports 75- $\Omega$  single-ended trace and 100- $\Omega$  differential trace routing on the top layer of the board. This is typically done with a Layer 2 ground plane reference for the 100- $\Omega$  differential traces and a second ground plane at Layer 3 reference for the 75- $\Omega$  single-ended traces.
3. Use single-ended uncoupled trace designed with 75- $\Omega$  impedance for signal routing to SDO and  $\overline{SDO}$ . The trace width is typically 8-10 mil reference to a ground plane at Layer 3.
4. Use coupled differential traces with 100- $\Omega$  impedance for signal routing to SDI and  $\overline{SDI}$ . They are usually 5-mil to 8-mil trace width reference to a ground plane at Layer 2.
5. Place anti-pad (ground relief) on the power and ground planes directly under the 4.7- $\mu$ F AC-coupling capacitor, return loss network, and IC landing pads to minimize parasitic capacitance. The size of the anti-pad depends on the board stackup and can be determined by a 3-dimension electromagnetic simulation tool.
6. Use a well-designed BNC footprint to ensure the BNC's signal landing pad achieves 75- $\Omega$  characteristic impedance. BNC suppliers usually provide recommendations on BNC footprint for best results.
7. Keep trace length short between the BNC and SDO. The trace routing for SDO and  $\overline{SDO}$  must be symmetrical, approximately equal lengths, and equal loading.
8. The exposed pad EP of the package must be connected to the ground plane through an array of vias. These vias are solder-masked to avoid solder flow into the plated-through holes during the board manufacturing process.
9. Connect each supply pin ( $V_{CC}$  and  $V_{EE}$ ) to the power or ground planes with a short via. The via is usually placed tangent to the landing pads of the supply pins with the shortest trace possible.
10. Power-supply bypass capacitors must be placed close to the supply pins.



## 11 Device and Documentation Support

### 11.1 Community Resources

The following links connect to TI community resources. Linked contents are provided "AS IS" by the respective contributors. They do not constitute TI specifications and do not necessarily reflect TI's views; see TI's [Terms of Use](#).

**TI E2E™ Online Community** *TI's Engineer-to-Engineer (E2E) Community*. Created to foster collaboration among engineers. At [e2e.ti.com](http://e2e.ti.com), you can ask questions, share knowledge, explore ideas and help solve problems with fellow engineers.

**Design Support** *TI's Design Support* Quickly find helpful E2E forums along with design support tools and contact information for technical support.

### 11.2 Trademarks

E2E is a trademark of Texas Instruments.  
All other trademarks are the property of their respective owners.

### 11.3 Electrostatic Discharge Caution



These devices have limited built-in ESD protection. The leads should be shorted together or the device placed in conductive foam during storage or handling to prevent electrostatic damage to the MOS gates.

### 11.4 Glossary

[SLYZ022](#) — *TI Glossary*.

This glossary lists and explains terms, acronyms, and definitions.

## 12 Mechanical, Packaging, and Orderable Information

The following pages include mechanical, packaging, and orderable information. This information is the most current data available for the designated devices. This data is subject to change without notice and revision of this document. For browser-based versions of this data sheet, refer to the left-hand navigation.

**PACKAGING INFORMATION**

Orderable Device	Status (1)	Package Type	Package Drawing	Pins	Package Qty	Eco Plan (2)	Lead/Ball Finish (6)	MSL Peak Temp (3)	Op Temp (°C)	Device Marking (4/5)	Samples
LMH0302SQ/NOPB	ACTIVE	WQFN	RUM	16	1000	Green (RoHS & no Sb/Br)	CU SN	Level-3-260C-168 HR	-40 to 85	L0302	<a href="#">Samples</a>
LMH0302SQE/NOPB	ACTIVE	WQFN	RUM	16	250	Green (RoHS & no Sb/Br)	CU SN	Level-3-260C-168 HR	-40 to 85	L0302	<a href="#">Samples</a>
LMH0302SQX/NOPB	ACTIVE	WQFN	RUM	16	4500	Green (RoHS & no Sb/Br)	CU SN	Level-3-260C-168 HR	-40 to 85	L0302	<a href="#">Samples</a>

(1) The marketing status values are defined as follows:

**ACTIVE:** Product device recommended for new designs.

**LIFEBUY:** TI has announced that the device will be discontinued, and a lifetime-buy period is in effect.

**NRND:** Not recommended for new designs. Device is in production to support existing customers, but TI does not recommend using this part in a new design.

**PREVIEW:** Device has been announced but is not in production. Samples may or may not be available.

**OBsolete:** TI has discontinued the production of the device.

(2) Eco Plan - The planned eco-friendly classification: Pb-Free (RoHS), Pb-Free (RoHS Exempt), or Green (RoHS & no Sb/Br) - please check <http://www.ti.com/productcontent> for the latest availability information and additional product content details.

**TBD:** The Pb-Free/Green conversion plan has not been defined.

**Pb-Free (RoHS):** TI's terms "Lead-Free" or "Pb-Free" mean semiconductor products that are compatible with the current RoHS requirements for all 6 substances, including the requirement that lead not exceed 0.1% by weight in homogeneous materials. Where designed to be soldered at high temperatures, TI Pb-Free products are suitable for use in specified lead-free processes.

**Pb-Free (RoHS Exempt):** This component has a RoHS exemption for either 1) lead-based flip-chip solder bumps used between the die and package, or 2) lead-based die adhesive used between the die and leadframe. The component is otherwise considered Pb-Free (RoHS compatible) as defined above.

**Green (RoHS & no Sb/Br):** TI defines "Green" to mean Pb-Free (RoHS compatible), and free of Bromine (Br) and Antimony (Sb) based flame retardants (Br or Sb do not exceed 0.1% by weight in homogeneous material)

(3) MSL, Peak Temp. - The Moisture Sensitivity Level rating according to the JEDEC industry standard classifications, and peak solder temperature.

(4) There may be additional marking, which relates to the logo, the lot trace code information, or the environmental category on the device.

(5) Multiple Device Markings will be inside parentheses. Only one Device Marking contained in parentheses and separated by a "~" will appear on a device. If a line is indented then it is a continuation of the previous line and the two combined represent the entire Device Marking for that device.

(6) Lead/Ball Finish - Orderable Devices may have multiple material finish options. Finish options are separated by a vertical ruled line. Lead/Ball Finish values may wrap to two lines if the finish value exceeds the maximum column width.

**Important Information and Disclaimer:** The information provided on this page represents TI's knowledge and belief as of the date that it is provided. TI bases its knowledge and belief on information provided by third parties, and makes no representation or warranty as to the accuracy of such information. Efforts are underway to better integrate information from third parties. TI has taken and

continues to take reasonable steps to provide representative and accurate information but may not have conducted destructive testing or chemical analysis on incoming materials and chemicals. TI and TI suppliers consider certain information to be proprietary, and thus CAS numbers and other limited information may not be available for release.

In no event shall TI's liability arising out of such information exceed the total purchase price of the TI part(s) at issue in this document sold by TI to Customer on an annual basis.

**TAPE AND REEL INFORMATION**

**QUADRANT ASSIGNMENTS FOR PIN 1 ORIENTATION IN TAPE**

\*All dimensions are nominal

Device	Package Type	Package Drawing	Pins	SPQ	Reel Diameter (mm)	Reel Width W1 (mm)	A0 (mm)	B0 (mm)	K0 (mm)	P1 (mm)	W (mm)	Pin1 Quadrant
LMH0302SQ/NOPB	WQFN	RUM	16	1000	178.0	12.4	4.3	4.3	1.3	8.0	12.0	Q1
LMH0302SQE/NOPB	WQFN	RUM	16	250	178.0	12.4	4.3	4.3	1.3	8.0	12.0	Q1
LMH0302SQX/NOPB	WQFN	RUM	16	4500	330.0	12.4	4.3	4.3	1.3	8.0	12.0	Q1

**TAPE AND REEL BOX DIMENSIONS**

\*All dimensions are nominal

Device	Package Type	Package Drawing	Pins	SPQ	Length (mm)	Width (mm)	Height (mm)
LMH0302SQ/NOPB	WQFN	RUM	16	1000	210.0	185.0	35.0
LMH0302SQE/NOPB	WQFN	RUM	16	250	210.0	185.0	35.0
LMH0302SQX/NOPB	WQFN	RUM	16	4500	367.0	367.0	35.0



## IMPORTANT NOTICE

Texas Instruments Incorporated and its subsidiaries (TI) reserve the right to make corrections, enhancements, improvements and other changes to its semiconductor products and services per JESD46, latest issue, and to discontinue any product or service per JESD48, latest issue. Buyers should obtain the latest relevant information before placing orders and should verify that such information is current and complete. All semiconductor products (also referred to herein as "components") are sold subject to TI's terms and conditions of sale supplied at the time of order acknowledgment.

TI warrants performance of its components to the specifications applicable at the time of sale, in accordance with the warranty in TI's terms and conditions of sale of semiconductor products. Testing and other quality control techniques are used to the extent TI deems necessary to support this warranty. Except where mandated by applicable law, testing of all parameters of each component is not necessarily performed.

TI assumes no liability for applications assistance or the design of Buyers' products. Buyers are responsible for their products and applications using TI components. To minimize the risks associated with Buyers' products and applications, Buyers should provide adequate design and operating safeguards.

TI does not warrant or represent that any license, either express or implied, is granted under any patent right, copyright, mask work right, or other intellectual property right relating to any combination, machine, or process in which TI components or services are used. Information published by TI regarding third-party products or services does not constitute a license to use such products or services or a warranty or endorsement thereof. Use of such information may require a license from a third party under the patents or other intellectual property of the third party, or a license from TI under the patents or other intellectual property of TI.

Reproduction of significant portions of TI information in TI data books or data sheets is permissible only if reproduction is without alteration and is accompanied by all associated warranties, conditions, limitations, and notices. TI is not responsible or liable for such altered documentation. Information of third parties may be subject to additional restrictions.

Resale of TI components or services with statements different from or beyond the parameters stated by TI for that component or service voids all express and any implied warranties for the associated TI component or service and is an unfair and deceptive business practice. TI is not responsible or liable for any such statements.

Buyer acknowledges and agrees that it is solely responsible for compliance with all legal, regulatory and safety-related requirements concerning its products, and any use of TI components in its applications, notwithstanding any applications-related information or support that may be provided by TI. Buyer represents and agrees that it has all the necessary expertise to create and implement safeguards which anticipate dangerous consequences of failures, monitor failures and their consequences, lessen the likelihood of failures that might cause harm and take appropriate remedial actions. Buyer will fully indemnify TI and its representatives against any damages arising out of the use of any TI components in safety-critical applications.

In some cases, TI components may be promoted specifically to facilitate safety-related applications. With such components, TI's goal is to help enable customers to design and create their own end-product solutions that meet applicable functional safety standards and requirements. Nonetheless, such components are subject to these terms.

No TI components are authorized for use in FDA Class III (or similar life-critical medical equipment) unless authorized officers of the parties have executed a special agreement specifically governing such use.

Only those TI components which TI has specifically designated as military grade or "enhanced plastic" are designed and intended for use in military/aerospace applications or environments. Buyer acknowledges and agrees that any military or aerospace use of TI components which have **not** been so designated is solely at the Buyer's risk, and that Buyer is solely responsible for compliance with all legal and regulatory requirements in connection with such use.

TI has specifically designated certain components as meeting ISO/TS16949 requirements, mainly for automotive use. In any case of use of non-designated products, TI will not be responsible for any failure to meet ISO/TS16949.

### Products

Audio	<a href="http://www.ti.com/audio">www.ti.com/audio</a>
Amplifiers	<a href="http://amplifier.ti.com">amplifier.ti.com</a>
Data Converters	<a href="http://dataconverter.ti.com">dataconverter.ti.com</a>
DLP® Products	<a href="http://www.dlp.com">www.dlp.com</a>
DSP	<a href="http://dsp.ti.com">dsp.ti.com</a>
Clocks and Timers	<a href="http://www.ti.com/clocks">www.ti.com/clocks</a>
Interface	<a href="http://interface.ti.com">interface.ti.com</a>
Logic	<a href="http://logic.ti.com">logic.ti.com</a>
Power Mgmt	<a href="http://power.ti.com">power.ti.com</a>
Microcontrollers	<a href="http://microcontroller.ti.com">microcontroller.ti.com</a>
RFID	<a href="http://www.ti-rfid.com">www.ti-rfid.com</a>
OMAP Applications Processors	<a href="http://www.ti.com/omap">www.ti.com/omap</a>
Wireless Connectivity	<a href="http://www.ti.com/wirelessconnectivity">www.ti.com/wirelessconnectivity</a>

### Applications

Automotive and Transportation	<a href="http://www.ti.com/automotive">www.ti.com/automotive</a>
Communications and Telecom	<a href="http://www.ti.com/communications">www.ti.com/communications</a>
Computers and Peripherals	<a href="http://www.ti.com/computers">www.ti.com/computers</a>
Consumer Electronics	<a href="http://www.ti.com/consumer-apps">www.ti.com/consumer-apps</a>
Energy and Lighting	<a href="http://www.ti.com/energy">www.ti.com/energy</a>
Industrial	<a href="http://www.ti.com/industrial">www.ti.com/industrial</a>
Medical	<a href="http://www.ti.com/medical">www.ti.com/medical</a>
Security	<a href="http://www.ti.com/security">www.ti.com/security</a>
Space, Avionics and Defense	<a href="http://www.ti.com/space-avionics-defense">www.ti.com/space-avionics-defense</a>
Video and Imaging	<a href="http://www.ti.com/video">www.ti.com/video</a>

### TI E2E Community

[e2e.ti.com](http://e2e.ti.com)

## Looking for pricing, stock, or lifecycle information?

Click below to explore more details on WIN SOURCE:

 [View LMH0302SQ/NOPB on WIN SOURCE](#)

 [Texas Instruments](#) Information

## Optimize Your Supply Chain with WIN SOURCE Solutions

-  Global Sourcing Solution
-  Obsolete Management
-  Cost Control Management
-  Shortage Management
-  Alternative Solution
-  Excess Inventory Management