

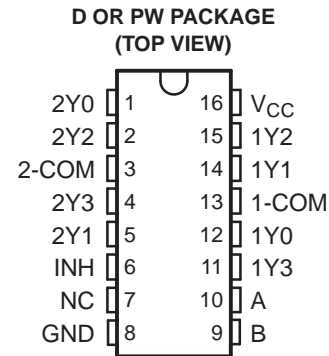

## FEATURES

- Qualified for Automotive Applications
- Injection-Current Cross Coupling <1 mV/mA (see [Figure 1](#))
- Low Crosstalk Between Switches
- Pin Compatible With SN74HC4052, SN74LV4052A, and CD4052B
- 2-V to 6-V  $V_{CC}$  Operation



NC – No internal connection

## DESCRIPTION/ORDERING INFORMATION

This dual 4-to-1 CMOS analog multiplexer/demultiplexer is pin compatible with the 4052 function and also features injection-current effect control. This feature has excellent value in automotive applications where voltages in excess of normal supply voltages are common.

The injection-current effect control allows signals at disabled analog input channels to exceed the supply voltage without affecting the signal of the enabled analog channel. This eliminates the need for external diode/resistor networks typically used to keep the analog channel signals within the supply voltage range.

### ORDERING INFORMATION<sup>(1)</sup>

$T_A$	PACKAGE <sup>(2)</sup>		ORDERABLE PART NUMBER	TOP-SIDE MARKING
–40°C to 125°C	SOIC – D	Reel of 2500	SN74HC4852QDRQ1	HC4852Q
	TSSOP – PW	Reel of 2000	SN74HC4852QPWRQ1	HC4852Q

- (1) For the most current package and ordering information, see the Package Option Addendum at the end of this document, or see the TI web site at [www.ti.com](http://www.ti.com).
- (2) Package drawings, thermal data, and symbolization are available at [www.ti.com/packaging](http://www.ti.com/packaging).

### FUNCTION TABLE

INPUTS			ON CHANNEL
INH	B	A	
L	L	L	1Y0, 2Y0
L	L	H	1Y1, 2Y1
L	H	L	1Y2, 2Y2
L	H	H	1Y3, 2Y3
H	X	X	None



Please be aware that an important notice concerning availability, standard warranty, and use in critical applications of Texas Instruments semiconductor products and disclaimers thereto appears at the end of this data sheet.

# SN74HC4852-Q1

## DUAL 4-TO-1 CHANNEL ANALOG MULTIPLEXER/DEMULTIPLEXER

### WITH INJECTION-CURRENT EFFECT CONTROL

SCLS705A—DECEMBER 2006—REVISED FEBRUARY 2008

#### LOGIC DIAGRAM (POSITIVE LOGIC)

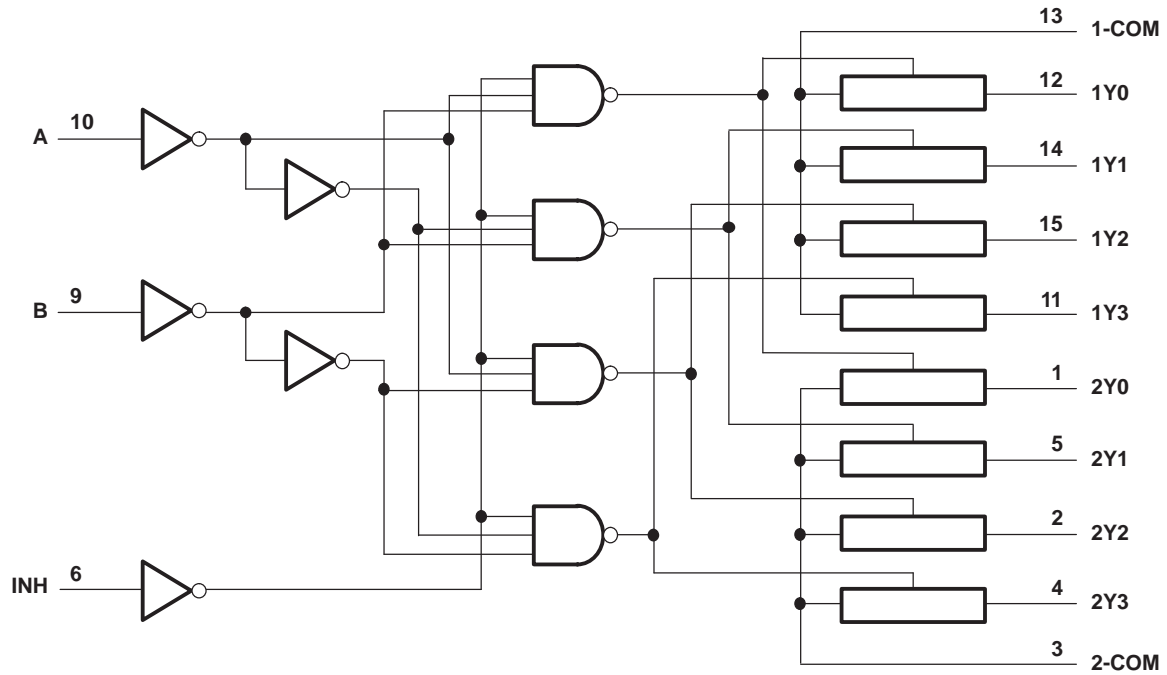

### Absolute Maximum Ratings<sup>(1)</sup>

over operating free-air temperature range (unless otherwise noted)

		MIN	MAX	UNIT
V <sub>CC</sub>	Supply voltage range	−0.5	7	V
V <sub>I</sub>	Input voltage range <sup>(2)</sup>	−0.5	V <sub>CC</sub> + 0.5	V
V <sub>IO</sub>	Switch I/O voltage range <sup>(2)(3)</sup>	−0.5	V <sub>CC</sub> + 0.5	V
I <sub>IK</sub>	Input clamp current	V <sub>I</sub> < 0 or V <sub>I</sub> > V <sub>CC</sub>		±20 mA
I <sub>IOK</sub>	I/O diode current	V <sub>IO</sub> < 0 or V <sub>IO</sub> > V <sub>CC</sub>		±20 mA
I <sub>S</sub>	Switch through current	V <sub>IO</sub> = 0 to V <sub>CC</sub>		±25 mA
Continuous current through V <sub>CC</sub> or GND				±50 mA
θ <sub>JA</sub>	Package thermal impedance <sup>(4)</sup>	D package		73 °C/W
		PW package		108
T <sub>stg</sub>	Storage temperature range	−65	150	°C
ESD	Electrostatic discharge protection	Human-Body Model (HBM)		2000 V
		Machine Model (MM)		200
		Charged-Device Model (CDM)		1000

- (1) Stresses beyond those listed under "absolute maximum ratings" may cause permanent damage to the device. These are stress ratings only, and functional operation of the device at these or any other conditions beyond those indicated under "recommended operating conditions" is not implied. Exposure to absolute-maximum-rated conditions for extended periods may affect device reliability.
- (2) The input and output voltage ratings may be exceeded if the input and output current ratings are observed.
- (3) This value is limited to 5.5 V maximum.
- (4) The package thermal impedance is calculated in accordance with JEDEC 51-7.

### Recommended Operating Conditions<sup>(1)</sup>

		MIN	MAX	UNIT
V <sub>CC</sub>	Supply voltage	2	6	V
V <sub>IH</sub>	High-level input voltage, control inputs	V <sub>CC</sub> = 2 V		1.5
		V <sub>CC</sub> = 3 V		2.1
		V <sub>CC</sub> = 3.3 V		2.3
		V <sub>CC</sub> = 4.5 V		3.15
		V <sub>CC</sub> = 6 V		4.2
V <sub>IL</sub>	Low-level input voltage, control inputs	V <sub>CC</sub> = 2 V		0.5
		V <sub>CC</sub> = 3 V		0.9
		V <sub>CC</sub> = 3.3 V		1
		V <sub>CC</sub> = 4.5 V		1.35
		V <sub>CC</sub> = 6 V		1.8
V <sub>I</sub>	Control input voltage	0	V <sub>CC</sub>	V
V <sub>IO</sub>	Input/output voltage	0	V <sub>CC</sub>	V
Δt/Δv	Input transition rise or fall rate	V <sub>CC</sub> = 2 V		1000
		V <sub>CC</sub> = 3 V		800
		V <sub>CC</sub> = 3.3 V		700
		V <sub>CC</sub> = 4.5 V		500
		V <sub>CC</sub> = 6 V		400
T <sub>A</sub>	Operating free-air temperature	−40	125	°C

- (1) All unused inputs of the device must be held at V<sub>CC</sub> or GND to ensure proper device operation. Refer to the TI application report, *Implications of Slow or Floating CMOS Inputs*, literature number SCBA004.

# SN74HC4852-Q1

## DUAL 4-TO-1 CHANNEL ANALOG MULTIPLEXER/DEMULTIPLEXER WITH INJECTION-CURRENT EFFECT CONTROL

SCLS705A–DECEMBER 2006–REVISED FEBRUARY 2008

### Electrical Characteristics

over recommended operating free-air temperature range (unless otherwise noted)

PARAMETER	TEST CONDITIONS	V <sub>CC</sub>	T <sub>A</sub> = 25°C			–40°C to 85°C		–40°C to 125°C		UNIT
			MIN	TYP	MAX	MIN	MAX	MIN	MAX	
r <sub>on</sub>	On-state switch resistance	I <sub>S</sub> ≤ 2 mA, V <sub>I</sub> = V <sub>CC</sub> to GND, V <sub>INH</sub> = V <sub>IL</sub> (see Figure 5)	2 V	500	650	670		700		Ω
			3 V	215	280	320		360		
			3.3 V	210	270	305		345		
			4.5 V	160	210	240		270		
			6 V	150	195	220		250		
Δr <sub>on</sub>	Difference in on-state resistance between switches	I <sub>S</sub> ≤ 2 mA, V <sub>I</sub> = V <sub>CC</sub> /2, V <sub>INH</sub> = V <sub>IL</sub>	2 V	4	20	24		26		Ω
			3 V	2	14	16		18		
			3.3 V	2	14	16		18		
			4.5 V	2	10	14		18		
			6 V	3	11	15		20		
I <sub>I</sub>	Control input current	V <sub>I</sub> = V <sub>CC</sub> or GND	6 V		±0.1		±0.1		±1	μA
I <sub>S(off)</sub>	Off-state switch leakage current (any one channel)	V <sub>I</sub> = V <sub>CC</sub> or GND, V <sub>INH</sub> = V <sub>IH</sub> (see Figure 6)	6 V		±0.1		±0.5		±1	μA
	Off-state switch leakage current (common channel)	V <sub>I</sub> = V <sub>CC</sub> or GND, V <sub>INH</sub> = V <sub>IH</sub> (see Figure 7)			±0.2		±2		±4	
I <sub>S(on)</sub>	On-state switch leakage current	V <sub>I</sub> = V <sub>CC</sub> or GND, V <sub>INH</sub> = V <sub>IL</sub> (see Figure 8)	6 V		±0.1		±0.5		±1	μA
I <sub>CC</sub>	Supply current	V <sub>I</sub> = V <sub>CC</sub> or GND	6 V		2		5		10	μA
C <sub>IC</sub>	Control input capacitance	A, B, INH		3.5	10		10		10	pF
C <sub>IS</sub>	Common terminal capacitance	Switch off		22	40		40		40	pF
C <sub>OS</sub>	Switch terminal capacitance	Switch off		6.7	15		15		15	pF

### Injection-Current Coupling Specifications

T<sub>A</sub> = –40°C to 125°C (see Figure 1)

PARAMETER	V <sub>CC</sub>	TEST CONDITIONS		MIN	TYP <sup>(1)</sup>	MAX	UNIT
V <sub>Δout</sub>	3.3 V	I <sub>I</sub> <sup>(2)</sup> ≤ 1 mA	R <sub>S</sub> ≤ 3.9 kΩ	0.05		1	mV
	5 V			0.1		1	
	3.3 V	I <sub>I</sub> <sup>(2)</sup> ≤ 10 mA	R <sub>S</sub> ≤ 3.9 kΩ	0.345		5	
	5 V			0.067		5	
	3.3 V	I <sub>I</sub> <sup>(2)</sup> ≤ 1 mA	R <sub>S</sub> ≤ 20 kΩ	0.05		2	
	5 V			0.11		2	
	3.3 V	I <sub>I</sub> <sup>(2)</sup> ≤ 10 mA	R <sub>S</sub> ≤ 20 kΩ	0.05		20	
	5 V			0.024		20	

(1) Typical values are measured at T<sub>A</sub> = 25°C.

(2) I<sub>I</sub> = total current injected into all disabled channels

### Switching Characteristics

$V_{CC} = 2\text{ V}$ ,  $C_L = 50\text{ pF}$ , over recommended operating free-air temperature range (unless otherwise noted) (see [Figure 9](#) through [Figure 14](#))

PARAMETER	FROM (INPUT)	TO (OUTPUT)	$T_A = 25^\circ\text{C}$			$-40^\circ\text{C to } 85^\circ\text{C}$		$-40^\circ\text{C to } 125^\circ\text{C}$		UNIT	
			MIN	TYP	MAX	MIN	MAX	MIN	MAX		
$t_{PLH}$ $t_{PHL}$	Propagation delay time	COM or Yn	Yn or COM	9.5	19.5	33	8	34	7	35	ns
$t_{PLH}$ $t_{PHL}$	Propagation delay time	Channel Select	COM or Yn	14.6	24.5	38	14.4	40	12.8	42	ns
$t_{PZH}$ $t_{PZL}$	Enable delay time	INH	COM or Yn	15	23.6	47.5	13.8	52.5	12.5	57.5	ns
$t_{PHZ}$ $t_{PLZ}$	Disable delay time	INH	COM or Yn	34.5	48.4	100	34.3	105	34	115	ns

### Switching Characteristics

$V_{CC} = 3\text{ V}$ ,  $C_L = 50\text{ pF}$ , over recommended operating free-air temperature range (unless otherwise noted) (see [Figure 9](#) through [Figure 14](#))

PARAMETER	FROM (INPUT)	TO (OUTPUT)	$T_A = 25^\circ\text{C}$			$-40^\circ\text{C to } 85^\circ\text{C}$		$-40^\circ\text{C to } 125^\circ\text{C}$		UNIT	
			MIN	TYP	MAX	MIN	MAX	MIN	MAX		
$t_{PLH}$ $t_{PHL}$	Propagation delay time	COM or Yn	Yn or COM	3.6	12	17.5	4.5	19	3.2	20.5	ns
$t_{PLH}$ $t_{PHL}$	Propagation delay time	Channel Select	COM or Yn	7.4	14.6	21	8.3	22.5	7.2	24	ns
$t_{PZH}$ $t_{PZL}$	Enable delay time	INH	COM or Yn	7.9	13.8	45	6.2	50	5.5	55	ns
$t_{PHZ}$ $t_{PLZ}$	Disable delay time	INH	COM or Yn	31.2	44.5	90	31.5	100	31	110	ns

### Switching Characteristics

$V_{CC} = 3.3\text{ V}$ ,  $C_L = 50\text{ pF}$ , over recommended operating free-air temperature range (unless otherwise noted) (see [Figure 9](#) through [Figure 14](#))

PARAMETER	FROM (INPUT)	TO (OUTPUT)	$T_A = 25^\circ\text{C}$			$-40^\circ\text{C to } 85^\circ\text{C}$		$-40^\circ\text{C to } 125^\circ\text{C}$		UNIT	
			MIN	TYP	MAX	MIN	MAX	MIN	MAX		
$t_{PLH}$ $t_{PHL}$	Propagation delay time	COM or Yn	Yn or COM	3.9	11	15.5	4	17	3.2	18.5	ns
$t_{PLH}$ $t_{PHL}$	Propagation delay time	Channel Select	COM or Yn	6.4	13.5	19	6.5	20.5	5.5	22.5	ns
$t_{PZH}$ $t_{PZL}$	Enable delay time	INH	COM or Yn	7	12.7	42.5	6.4	47.5	5.4	52.5	ns
$t_{PHZ}$ $t_{PLZ}$	Disable delay time	INH	COM or Yn	30	43.9	85	29.6	95	29.5	105	ns

# SN74HC4852-Q1

## DUAL 4-TO-1 CHANNEL ANALOG MULTIPLEXER/DEMULTIPLEXER WITH INJECTION-CURRENT EFFECT CONTROL

SCLS705A–DECEMBER 2006–REVISED FEBRUARY 2008

### Switching Characteristics

$V_{CC} = 4.5\text{ V}$ ,  $C_L = 50\text{ pF}$ , over recommended operating free-air temperature range (unless otherwise noted) (see [Figure 9](#) through [Figure 14](#))

PARAMETER	FROM (INPUT)	TO (OUTPUT)	$T_A = 25^\circ\text{C}$			$-40^\circ\text{C to } 85^\circ\text{C}$		$-40^\circ\text{C to } 125^\circ\text{C}$		UNIT	
			MIN	TYP	MAX	MIN	MAX	MIN	MAX		
$t_{PLH}$ $t_{PHL}$	Propagation delay time	COM or Yn	Yn or COM	2.3	8.6	13	2.1	13.8	2	15.2	ns
$t_{PLH}$ $t_{PHL}$	Propagation delay time	Channel Select	COM or Yn	5.3	11	16.6	5.5	18	4.6	19	ns
$t_{PZH}$ $t_{PZL}$	Enable delay time	INH	COM or Yn	4	9.9	40	4.3	45	3.4	50	ns
$t_{PHZ}$ $t_{PLZ}$	Disable delay time	INH	COM or Yn	24.5	41.4	80	24.2	90	24	100	ns

### Switching Characteristics

$V_{CC} = 6\text{ V}$ ,  $C_L = 50\text{ pF}$ , over recommended operating free-air temperature range (unless otherwise noted) (see [Figure 9](#) through [Figure 14](#))

PARAMETER	FROM (INPUT)	TO (OUTPUT)	$T_A = 25^\circ\text{C}$			$-40^\circ\text{C to } 85^\circ\text{C}$		$-40^\circ\text{C to } 125^\circ\text{C}$		UNIT	
			MIN	TYP	MAX	MIN	MAX	MIN	MAX		
$t_{PLH}$ $t_{PHL}$	Propagation delay time	COM or Yn	Yn or COM	2	8	11.8	2.3	13	1.8	13.5	ns
$t_{PLH}$ $t_{PHL}$	Propagation delay time	Channel Select	COM or Yn	3.4	9.5	14.6	3.7	16	2.8	17.5	ns
$t_{PZH}$ $t_{PZL}$	Enable delay time	INH	COM or Yn	2.8	8.4	39	3	40	2	40	ns
$t_{PHZ}$ $t_{PLZ}$	Disable delay time	INH	COM or Yn	12.4	38	78	11.5	80	11	80	ns

### Operating Characteristics

$T_A = 25^\circ\text{C}$  (see [Figure 15](#))

PARAMETER		$V_{CC}$	TEST CONDITIONS	TYP	UNIT
$C_{pd}$	Power dissipation capacitance	3.3 V	No load	48	pF
		5 V		60	

**APPLICATION INFORMATION**

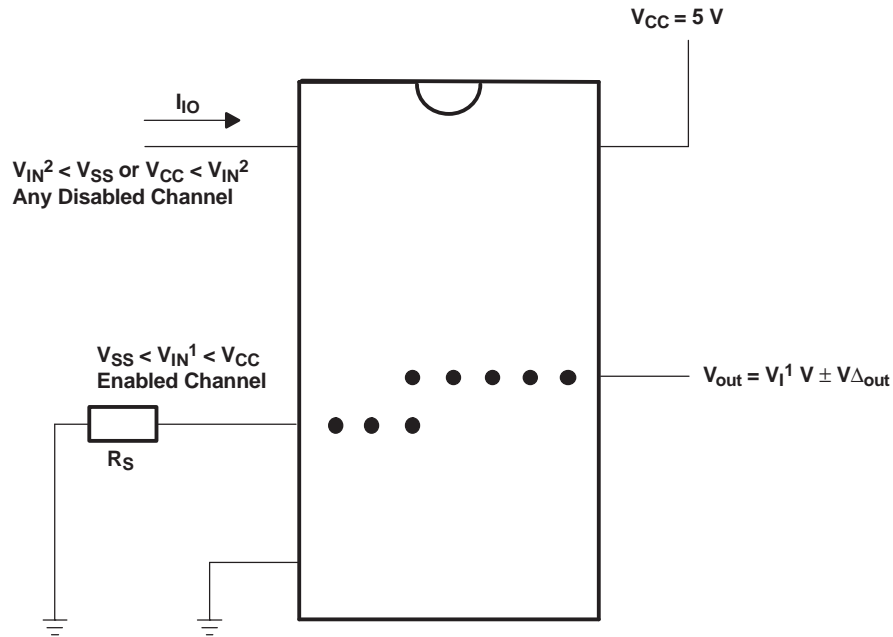

**Figure 1. Injection-Current Coupling Specification**

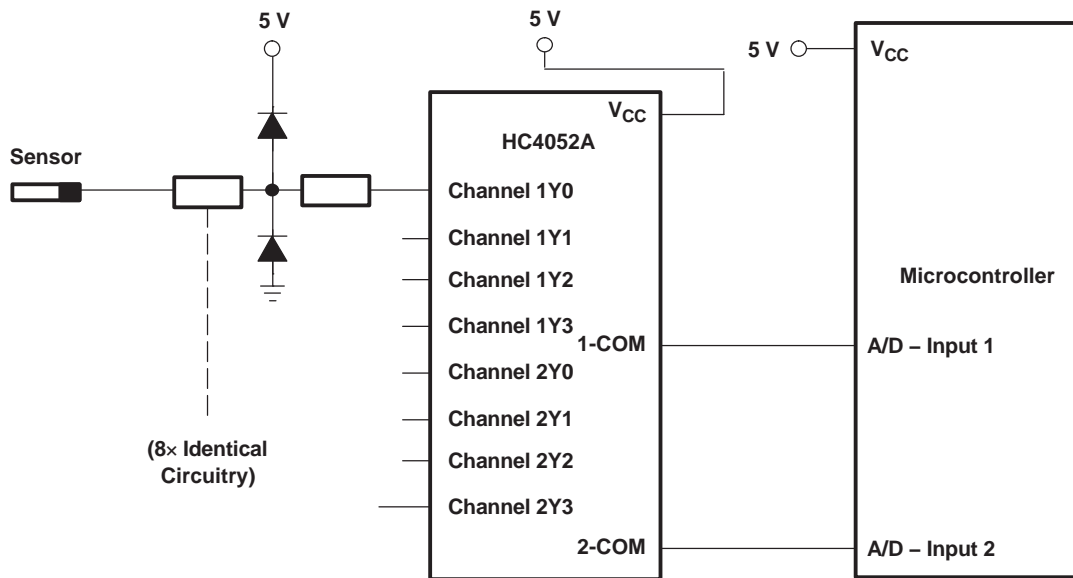

**Figure 2. Actual Technology Requires 32 Passive Components and One Extra 6-V Regulator to Suppress Injection Current Into a Standard HC4052 Multiplexer**

**SN74HC4852-Q1**  
**DUAL 4-TO-1 CHANNEL ANALOG MULTIPLEXER/DEMULTIPLEXER**  
**WITH INJECTION-CURRENT EFFECT CONTROL**

SCLS705A—DECEMBER 2006—REVISED FEBRUARY 2008

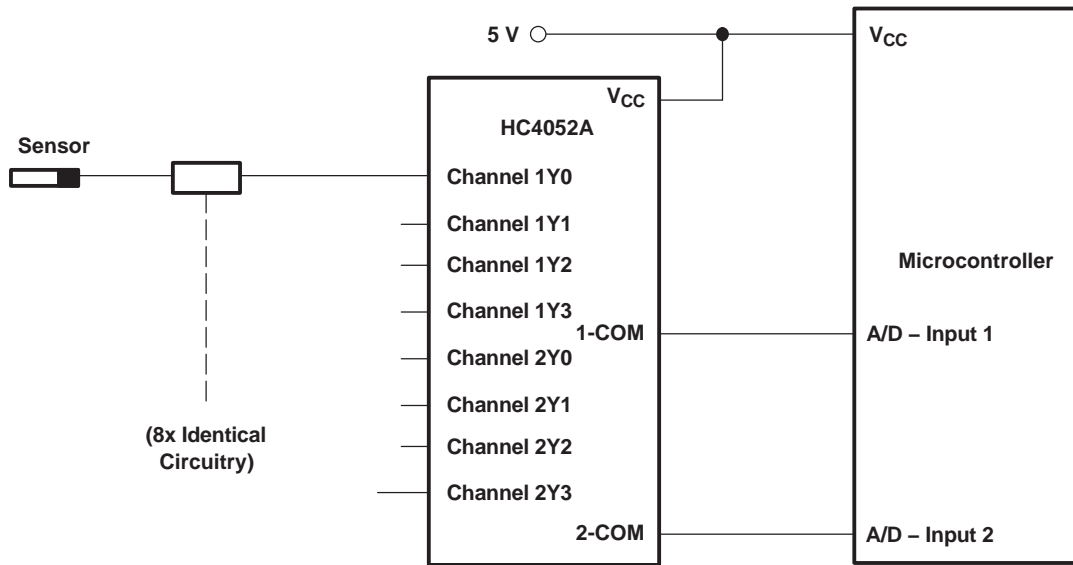

**Figure 3. Solution by Applying the HC4852 Multiplexer**

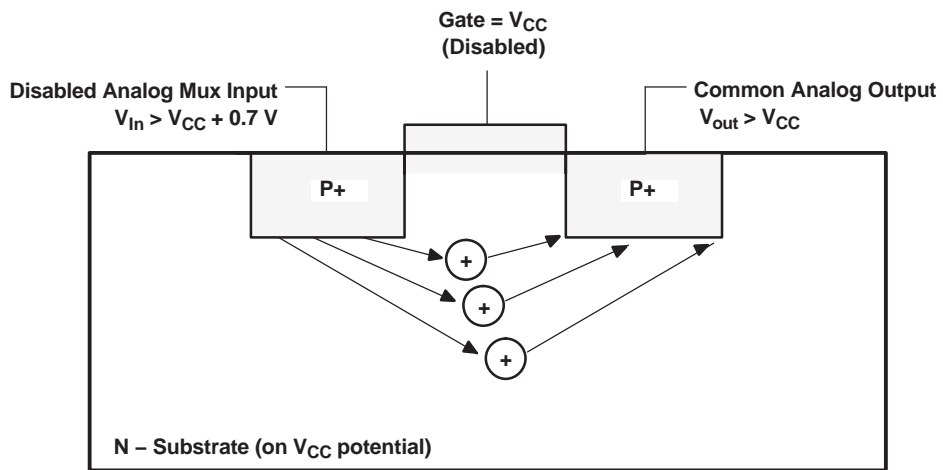

**Figure 4. Diagram of Bipolar Coupling Mechanism**  
**(Appears if  $V_{IN}$  Exceeds  $V_{CC}$ , Driving Injection Current Into the Substrate)**

PARAMETER MEASUREMENT INFORMATION

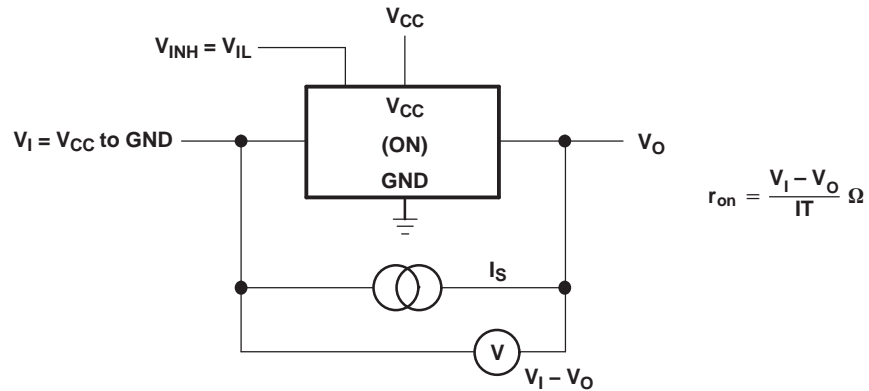

Figure 5. On-State Resistance Test Circuit

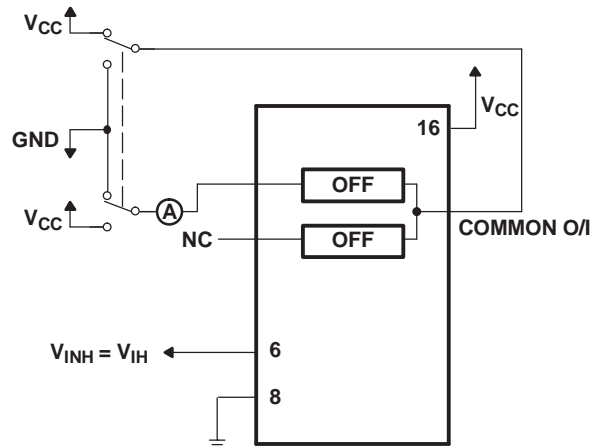

Figure 6. Maximum Off-Channel Leakage Current, Any One Channel, Test Setup

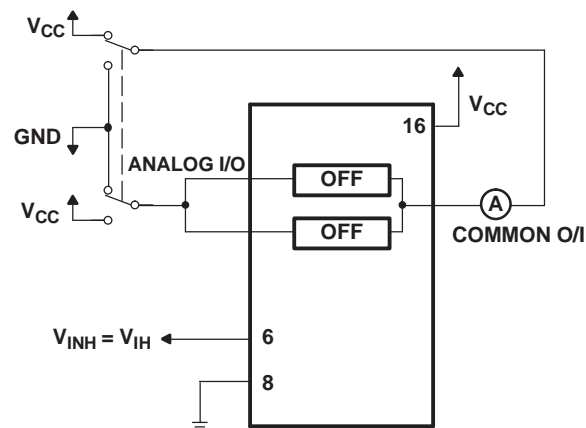
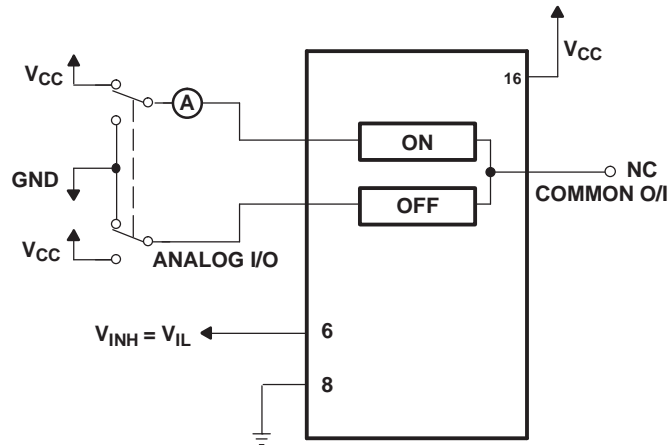
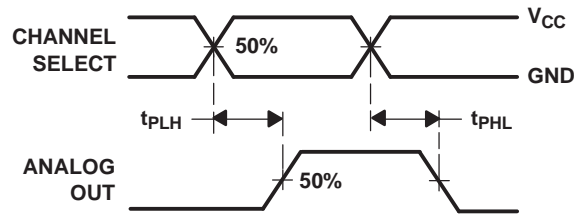

Figure 7. Maximum Off-Channel Leakage Current, Common Channel, Test Setup

**PARAMETER MEASUREMENT INFORMATION (continued)**



**Figure 8. Maximum On-Channel Leakage Current, Channel to Channel, Test Setup**



**Figure 9. Propagation Delays, Channel Select to Analog Out**

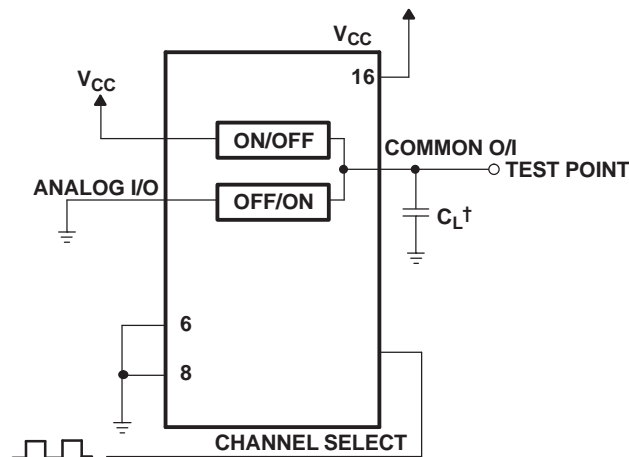

† Includes all probe and jig capacitance

**Figure 10. Propagation Delay, Channel Select to Analog Out, Test Setup**

PARAMETER MEASUREMENT INFORMATION (continued)

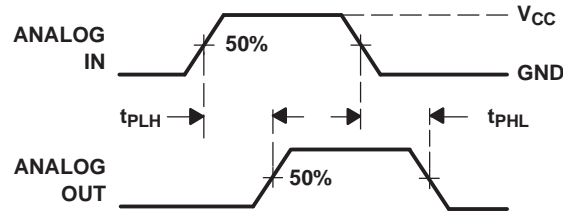
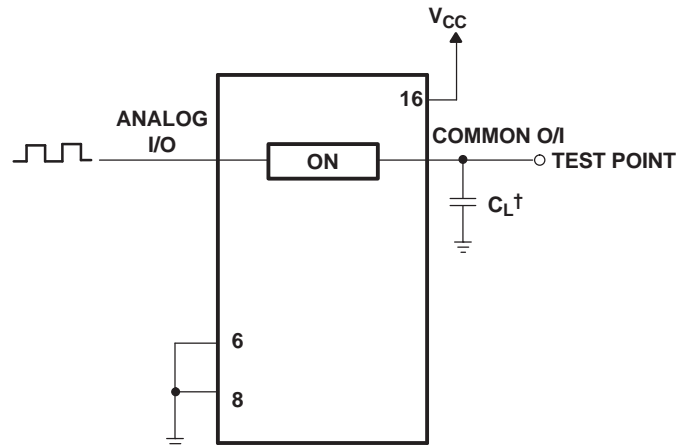

Figure 11. Propagation Delays, Analog In to Analog Out



† Includes all probe and jig capacitance

Figure 12. Propagation Delay, Analog In to Analog Out, Test Setup

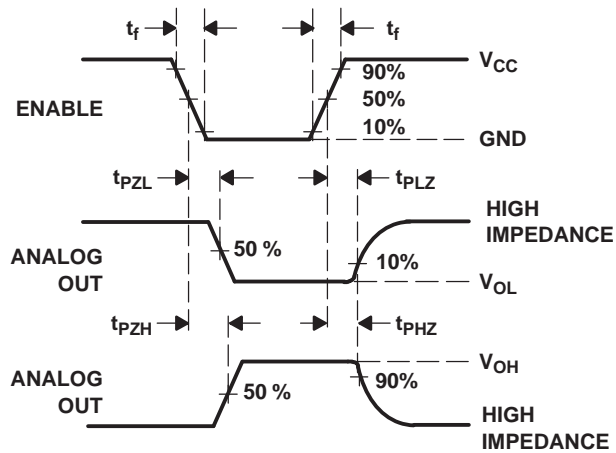
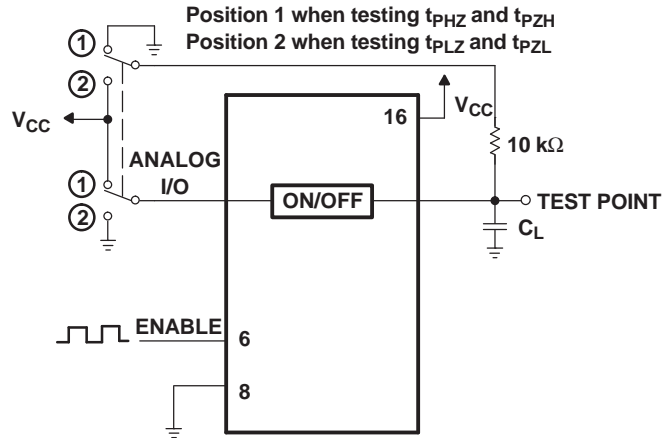
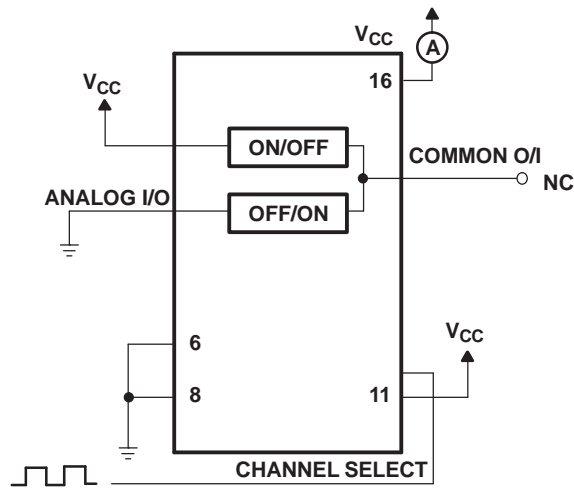

Figure 13. Propagation Delays, Enable to Analog Out

**PARAMETER MEASUREMENT INFORMATION (continued)**



**Figure 14. Propagation Delay, Enable to Analog Out, Test Setup**



**Figure 15. Power-Dissipation Capacitance, Test Setup**

**PACKAGING INFORMATION**

Orderable Device	Status (1)	Package Type	Package Drawing	Pins	Package Qty	Eco Plan (2)	Lead/Ball Finish	MSL Peak Temp (3)	Op Temp (°C)	Top-Side Markings (4)	Samples
SN74HC4852QDRQ1	ACTIVE	SOIC	D	16	2500	Green (RoHS & no Sb/Br)	CU NIPDAU	Level-1-260C-UNLIM	-40 to 125	HC4852Q	<a href="#">Samples</a>
SN74HC4852QPWRQ1	ACTIVE	TSSOP	PW	16	2000	Green (RoHS & no Sb/Br)	CU NIPDAU	Level-1-260C-UNLIM	-40 to 125	HC4852Q	<a href="#">Samples</a>

(1) The marketing status values are defined as follows:

**ACTIVE:** Product device recommended for new designs.

**LIFEBUY:** TI has announced that the device will be discontinued, and a lifetime-buy period is in effect.

**NRND:** Not recommended for new designs. Device is in production to support existing customers, but TI does not recommend using this part in a new design.

**PREVIEW:** Device has been announced but is not in production. Samples may or may not be available.

**OBsolete:** TI has discontinued the production of the device.

(2) Eco Plan - The planned eco-friendly classification: Pb-Free (RoHS), Pb-Free (RoHS Exempt), or Green (RoHS & no Sb/Br) - please check <http://www.ti.com/productcontent> for the latest availability information and additional product content details.

**TBD:** The Pb-Free/Green conversion plan has not been defined.

**Pb-Free (RoHS):** TI's terms "Lead-Free" or "Pb-Free" mean semiconductor products that are compatible with the current RoHS requirements for all 6 substances, including the requirement that lead not exceed 0.1% by weight in homogeneous materials. Where designed to be soldered at high temperatures, TI Pb-Free products are suitable for use in specified lead-free processes.

**Pb-Free (RoHS Exempt):** This component has a RoHS exemption for either 1) lead-based flip-chip solder bumps used between the die and package, or 2) lead-based die adhesive used between the die and leadframe. The component is otherwise considered Pb-Free (RoHS compatible) as defined above.

**Green (RoHS & no Sb/Br):** TI defines "Green" to mean Pb-Free (RoHS compatible), and free of Bromine (Br) and Antimony (Sb) based flame retardants (Br or Sb do not exceed 0.1% by weight in homogeneous material)

(3) MSL, Peak Temp. -- The Moisture Sensitivity Level rating according to the JEDEC industry standard classifications, and peak solder temperature.

(4) Multiple Top-Side Markings will be inside parentheses. Only one Top-Side Marking contained in parentheses and separated by a "~" will appear on a device. If a line is indented then it is a continuation of the previous line and the two combined represent the entire Top-Side Marking for that device.

**Important Information and Disclaimer:** The information provided on this page represents TI's knowledge and belief as of the date that it is provided. TI bases its knowledge and belief on information provided by third parties, and makes no representation or warranty as to the accuracy of such information. Efforts are underway to better integrate information from third parties. TI has taken and continues to take reasonable steps to provide representative and accurate information but may not have conducted destructive testing or chemical analysis on incoming materials and chemicals. TI and TI suppliers consider certain information to be proprietary, and thus CAS numbers and other limited information may not be available for release.

In no event shall TI's liability arising out of such information exceed the total purchase price of the TI part(s) at issue in this document sold by TI to Customer on an annual basis.

**OTHER QUALIFIED VERSIONS OF SN74HC4852-Q1 :**

- Catalog: [SN74HC4852](#)

NOTE: Qualified Version Definitions:

- Catalog - TI's standard catalog product

## TAPE AND REEL INFORMATION



### QUADRANT ASSIGNMENTS FOR PIN 1 ORIENTATION IN TAPE



\*All dimensions are nominal

Device	Package Type	Package Drawing	Pins	SPQ	Reel Diameter (mm)	Reel Width W1 (mm)	A0 (mm)	B0 (mm)	K0 (mm)	P1 (mm)	W (mm)	Pin1 Quadrant
SN74HC4852QPWRQ1	TSSOP	PW	16	2000	330.0	12.4	6.9	5.6	1.6	8.0	12.0	Q1

**TAPE AND REEL BOX DIMENSIONS**



\*All dimensions are nominal

Device	Package Type	Package Drawing	Pins	SPQ	Length (mm)	Width (mm)	Height (mm)
SN74HC4852QPWRQ1	TSSOP	PW	16	2000	367.0	367.0	35.0

D (R-PDSO-G16)

PLASTIC SMALL OUTLINE



- NOTES:
- A. All linear dimensions are in inches (millimeters).
  - B. This drawing is subject to change without notice.
  - C. Body length does not include mold flash, protrusions, or gate burrs. Mold flash, protrusions, or gate burrs shall not exceed 0.006 (0,15) each side.
  - D. Body width does not include interlead flash. Interlead flash shall not exceed 0.017 (0,43) each side.
  - E. Reference JEDEC MS-012 variation AC.

D (R-PDSO-G16)

PLASTIC SMALL OUTLINE



- NOTES:
- All linear dimensions are in millimeters.
  - This drawing is subject to change without notice.
  - Publication IPC-7351 is recommended for alternate designs.
  - Laser cutting apertures with trapezoidal walls and also rounding corners will offer better paste release. Customers should contact their board assembly site for stencil design recommendations. Refer to IPC-7525 for other stencil recommendations.
  - Customers should contact their board fabrication site for solder mask tolerances between and around signal pads.



NOTES:

1. All linear dimensions are in millimeters. Any dimensions in parenthesis are for reference only. Dimensioning and tolerancing per ASME Y14.5M.
2. This drawing is subject to change without notice.
3. This dimension does not include mold flash, protrusions, or gate burrs. Mold flash, protrusions, or gate burrs shall not exceed 0.15 mm per side.
4. This dimension does not include interlead flash. Interlead flash shall not exceed 0.25 mm per side.
5. Reference JEDEC registration MO-153.

# EXAMPLE BOARD LAYOUT

PW0016A

TSSOP - 1.2 mm max height

SMALL OUTLINE PACKAGE



LAND PATTERN EXAMPLE  
EXPOSED METAL SHOWN  
SCALE: 10X



SOLDER MASK DETAILS

4220204/A 02/2017

NOTES: (continued)

- 6. Publication IPC-7351 may have alternate designs.
- 7. Solder mask tolerances between and around signal pads can vary based on board fabrication site.

# EXAMPLE STENCIL DESIGN

PW0016A

TSSOP - 1.2 mm max height

SMALL OUTLINE PACKAGE



SOLDER PASTE EXAMPLE  
BASED ON 0.125 mm THICK STENCIL  
SCALE: 10X

4220204/A 02/2017

NOTES: (continued)

8. Laser cutting apertures with trapezoidal walls and rounded corners may offer better paste release. IPC-7525 may have alternate design recommendations.
9. Board assembly site may have different recommendations for stencil design.

## IMPORTANT NOTICE AND DISCLAIMER

TI PROVIDES TECHNICAL AND RELIABILITY DATA (INCLUDING DATASHEETS), DESIGN RESOURCES (INCLUDING REFERENCE DESIGNS), APPLICATION OR OTHER DESIGN ADVICE, WEB TOOLS, SAFETY INFORMATION, AND OTHER RESOURCES "AS IS" AND WITH ALL FAULTS, AND DISCLAIMS ALL WARRANTIES, EXPRESS AND IMPLIED, INCLUDING WITHOUT LIMITATION ANY IMPLIED WARRANTIES OF MERCHANTABILITY, FITNESS FOR A PARTICULAR PURPOSE OR NON-INFRINGEMENT OF THIRD PARTY INTELLECTUAL PROPERTY RIGHTS.

These resources are intended for skilled developers designing with TI products. You are solely responsible for (1) selecting the appropriate TI products for your application, (2) designing, validating and testing your application, and (3) ensuring your application meets applicable standards, and any other safety, security, or other requirements. These resources are subject to change without notice. TI grants you permission to use these resources only for development of an application that uses the TI products described in the resource. Other reproduction and display of these resources is prohibited. No license is granted to any other TI intellectual property right or to any third party intellectual property right. TI disclaims responsibility for, and you will fully indemnify TI and its representatives against, any claims, damages, costs, losses, and liabilities arising out of your use of these resources.

TI's products are provided subject to TI's Terms of Sale ([www.ti.com/legal/termsofsale.html](http://www.ti.com/legal/termsofsale.html)) or other applicable terms available either on [ti.com](http://ti.com) or provided in conjunction with such TI products. TI's provision of these resources does not expand or otherwise alter TI's applicable warranties or warranty disclaimers for TI products.

Mailing Address: Texas Instruments, Post Office Box 655303, Dallas, Texas 75265  
Copyright © 2018, Texas Instruments Incorporated

## Looking for pricing, stock, or lifecycle information?

Click below to explore more details on WIN SOURCE:

 [View SN74HC4852QDRQ1 on WIN SOURCE](#)

 [Texas Instruments](#) Information

## Optimize Your Supply Chain with WIN SOURCE Solutions

-  Global Sourcing Solution
-  Obsolete Management
-  Cost Control Management
-  Shortage Management
-  Alternative Solution
-  Excess Inventory Management