



THE DATASHEET OF TCA9554PWR



TCA9554 Low Voltage 8-Bit I²C and SMBus Low-Power I/O Expander With Interrupt Output and Configuration Registers

1 Features

- I²C to Parallel Port Expander
- Open-Drain Active-Low Interrupt Output
- Operating Power-Supply Voltage Range of 1.65 V to 5.5 V
- 5-V Tolerant I/O Ports
- 400-kHz Fast I²C Bus
- Three Hardware Address Pins Allow up to Eight Devices on the I²C/SMBus
- Input and Output Configuration Register
- Polarity Inversion Register
- Internal Power-On Reset
- Low Standby Current Consumption
- Power-Up With All Channels Configured as Inputs
- No Glitch on Power Up
- Noise Filter on SCL/SDA Inputs
- Latched Outputs With High-Current Drive Maximum Capability for Directly Driving LEDs
- Latch-Up Performance Exceeds 100 mA Per JESD 78, Class II
- ESD Protection Exceeds JESD 22
 - 2000-V Human-Body Model (A114-A)
 - 1000-V Charged-Device Model (C101)

2 Applications

- Servers
- Routers (Telecom Switching Equipment)
- Personal Computers
- Personal Electronics (for example: Gaming Consoles)
- Industrial Automation
- Products With GPIO-Limited Processors

3 Description

The TCA9554 is a 16-pin device that provides 8 bits of general purpose parallel input and output (I/O) expansion for the two-line bidirectional I²C bus (or SMBus) protocol. The device can operate with a power supply voltage ranging from 1.65 V to 5.5 V. The device supports both 100-kHz (Standard-mode) and 400-kHz (Fast-mode) clock frequencies. I/O expanders such as the TCA9554 provide a simple solution when additional I/Os are needed for switches, sensors, push-buttons, LEDs, fans, and other similar devices.

The features of the TCA9554 include an interrupt that is generated on the INT pin whenever an input port changes state. The A0, A1, and A2 hardware selectable address pins allow up to eight TCA9554 devices on the same I²C bus. The device can also be reset to its default state by cycling the power supply and causing a power-on reset.

Device Information⁽¹⁾

PART NUMBER	PACKAGE	BODY SIZE (NOM)
TCA9554	TSSOP (16)	5.00 mm × 4.40 mm
	SSOP (16)	4.90 mm × 3.90 mm
	SSOP (16)	6.20 mm × 5.30 mm
	SOIC (16)	7.50 mm × 10.30 mm

(1) For all available packages, see the orderable addendum at the end of the datasheet.

Simplified Block Diagram

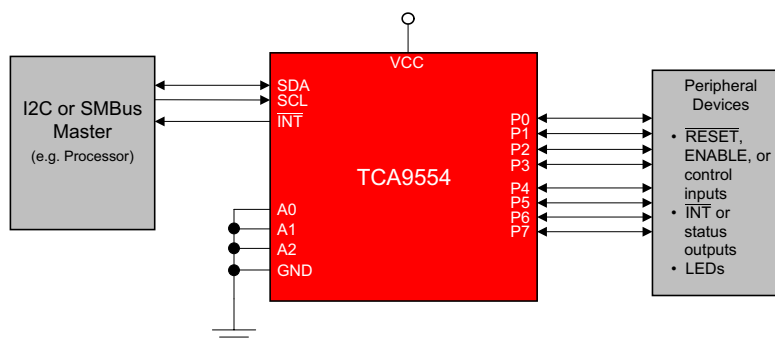

Table of Contents

1 Features	1	8.4 Device Functional Modes.....	17
2 Applications	1	8.5 Programming.....	17
3 Description	1	8.6 Register Maps	19
4 Revision History	2	9 Application and Implementation	24
5 Pin Configuration and Functions	4	9.1 Application Information.....	24
6 Specifications	5	9.2 Typical Application	24
6.1 Absolute Maximum Ratings	5	10 Power Supply Recommendations	27
6.2 ESD Ratings	5	10.1 Power-On Reset Requirements	27
6.3 Recommended Operating Conditions.....	5	11 Layout	29
6.4 Thermal Information	6	11.1 Layout Guidelines	29
6.5 Electrical Characteristics.....	6	11.2 Layout Example	29
6.6 I ² C Interface Timing Requirements.....	8	12 Device and Documentation Support	30
6.7 Switching Characteristics	8	12.1 Documentation Support	30
6.8 Typical Characteristics.....	9	12.2 Receiving Notification of Documentation Updates	30
7 Parameter Measurement Information	11	12.3 Community Resources.....	30
8 Detailed Description	14	12.4 Trademarks	30
8.1 Overview	14	12.5 Electrostatic Discharge Caution.....	30
8.2 Functional Block Diagram	15	12.6 Glossary	30
8.3 Feature Description.....	16	13 Mechanical, Packaging, and Orderable Information	30

4 Revision History

NOTE: Page numbers for previous revisions may differ from page numbers in the current version.

Changes from Revision D (August 2015) to Revision E	Page
• Added DW package.....	1
• Added Maximum junction temperature to the <i>Absolute Maximum Ratings</i> table	5
• Added I _{OL} for different T _j to the <i>Recommended Operating Conditions</i> table.....	5
• Changed I _{CC} standby into different input states, with increased maximums	7
• Changed C _{io} , C _i maximum	7
• Removed ΔI _{CC} spec from the <i>Electrical Characteristics</i> table, added ΔI _{CC} typical characteristics graph	7
• Clarified interrupt reset time (t _{ir}) with respect to falling edge of ACK related SCL pulse.	12
• Made changes to the <i>Interrupt Output (INT)</i> section.....	16
• Made changes to the <i>Reads</i> section	22
• Added the <i>Calculating Junction Temperature and Power Dissipation</i> section.....	25
• Changed recommended supply sequencing values	27
• Power on reset requirements relaxed	27

Changes from Revision C (May 2015) to Revision D	Page
• Added DB package.....	1

Changes from Revision B (October 2014) to Revision C	Page
• Added standby mode current for V _I = V _{CC} test condition.....	7
• Changed ΔI _{CC} for one P-port input at V _I = V _{CC} - 0.6, and other P-port I/O at V _I = V _{CC} or GND.	7
• Added clarification in datasheet that raising voltage above V _{CC} on P-port I/O will result in current flow from P-port to V _{CC}	16

Changes from Revision A (March 2012) to Revision B**Page**

- Added Handling Rating table, Feature Description section, Device Functional Modes, Application and Implementation section, Power Supply Recommendations section, Layout section, Device and Documentation Support section, and Mechanical, Packaging, and Orderable Information section. 1
 - Updated I_{OL} PARAMETER in the Electrical Characteristics table. 6
-

Changes from Original (November 2011) to Revision A**Page**

- Initial release of full version. 1
-

5 Pin Configuration and Functions

PW, DB, DBQ, or DW Package
16-Pin TSSOP, SSOP, SOIC
Top View

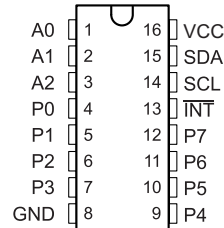

Pin Functions

PIN		I/O	DESCRIPTION
NAME	NO.		
A0	1	I	Address input. Connect directly to V_{CC} or ground
A1	2	I	Address input. Connect directly to V_{CC} or ground
A2	3	I	Address input. Connect directly to V_{CC} or ground
GND	8	—	Ground
INT	13	O	Interrupt output. Connect to V_{CC} through a pull-up resistor
P0	4	I/O	P-port input-output. Push-pull design structure. At power on, P0 is configured as an input
P1	5	I/O	P-port input-output. Push-pull design structure. At power on, P1 is configured as an input
P2	6	I/O	P-port input-output. Push-pull design structure. At power on, P2 is configured as an input
P3	7	I/O	P-port input-output. Push-pull design structure. At power on, P3 is configured as an input
P4	9	I/O	P-port input-output. Push-pull design structure. At power on, P4 is configured as an input
P5	10	I/O	P-port input-output. Push-pull design structure. At power on, P5 is configured as an input
P6	11	I/O	P-port input-output. Push-pull design structure. At power on, P6 is configured as an input
P7	12	I/O	P-port input-output. Push-pull design structure. At power on, P7 is configured as an input
SCL	14	I	Serial clock bus. Connect to V_{CC} through a pull-up resistor
SDA	15	I/O	Serial data bus. Connect to V_{CC} through a pull-up resistor
VCC	16	—	Supply voltage

6 Specifications

6.1 Absolute Maximum Ratings

over operating free-air temperature range (unless otherwise noted) ⁽¹⁾

		MIN	MAX	UNIT	
V _{CC}	Supply voltage	-0.5	6	V	
V _I	Input voltage ⁽²⁾	-0.5	6	V	
V _O	Output voltage ⁽²⁾	-0.5	6	V	
I _{IK}	Input clamp current		V _I < 0	-20	mA
I _{OK}	Output clamp current		V _O < 0	-20	mA
I _{I_{OK}}	Input-output clamp current		V _O < 0 or V _O > V _{CC}	±20	mA
I _{OL}	Continuous output low current through a single P-port		V _O = 0 to V _{CC}	50	mA
I _{OH}	Continuous output high current through a single P-port		V _O = 0 to V _{CC}	-50	mA
I _{CC}	Continuous current through GND by all P-ports			250	mA
	Continuous current through V _{CC}			-160	
T _{j(MAX)}	Maximum junction temperature			100	°C
T _{stg}	Storage temperature	-65	150		°C

- (1) Stresses beyond those listed under *Absolute Maximum Ratings* may cause permanent damage to the device. These are stress ratings only, which do not imply functional operation of the device at these or any other conditions beyond those indicated under *Recommended Operating Conditions*. Exposure to absolute-maximum-rated conditions for extended periods may affect device reliability.
- (2) The input negative-voltage and output voltage ratings may be exceeded if the input and output current ratings are observed.

6.2 ESD Ratings

		VALUE	UNIT
V _(ESD)	Electrostatic discharge	Human-body model (HBM), per ANSI/ESDA/JEDEC JS-001 ⁽¹⁾	±2000
		Charged-device model (CDM), per JEDEC specification JESD22-C101 ⁽²⁾	±1000

- (1) JEDEC document JEP155 states that 500-V HBM allows safe manufacturing with a standard ESD control process. Manufacturing with less than 500-V HBM is possible with the necessary precautions.
- (2) JEDEC document JEP157 states that 250-V CDM allows safe manufacturing with a standard ESD control process. Manufacturing with less than 250-V CDM is possible with the necessary precautions.

6.3 Recommended Operating Conditions

		MIN	MAX	UNIT	
V _{CC}	Supply voltage	1.65	5.5	V	
V _{IH}	High-level input voltage	SCL, SDA	V _{CC} = 1.65 V to 5.5 V	0.7 × V _{CC}	V _{CC} ⁽¹⁾
		A0, A1, A2, P7–P0	V _{CC} = 1.65 V to 2.7 V	0.7 × V _{CC}	5.5
			V _{CC} = 3 V to 5.5 V	0.8 × V _{CC}	5.5
V _{IL}	Low-level input voltage	SCL, SDA	V _{CC} = 1.65 V to 5.5 V	-0.5	0.3 × V _{CC}
		A0, A1, A2, P7–P0	V _{CC} = 1.65 V to 2.7 V	-0.5	0.3 × V _{CC}
			V _{CC} = 3 V to 5.5 V	-0.5	0.2 × V _{CC}
I _{OL}	Low-level output current ⁽²⁾	P00–P07, P10–P17	T _j ≤ 65°C	25	mA
			T _j ≤ 85°C	18	
			T _j ≤ 100°C	9	
		INT, SDA	T _j ≤ 85°C	6	
			T _j ≤ 100°C	3	
I _{OH}	High-level output current	Any P-port, P7–P0		-10	mA
I _{CC}	Continuous current through GND	All P-ports P7-P0, INT, and SDA		200	mA
	Continuous current through V _{CC}	All P-ports P7-P0		-80	

- (1) For voltages applied above V_{CC}, an increase in I_{CC} will result.
- (2) The values shown apply to specific junction temperatures, which depend on the R_{θJA} of the package used. See the [Calculating Junction Temperature and Power Dissipation](#) section on how to calculate the junction temperature.

Recommended Operating Conditions (continued)

		MIN	MAX	UNIT
T _A	Operating free-air temperature	-40	85	°C

6.4 Thermal Information

THERMAL METRIC ⁽¹⁾	TCA9554				UNIT	
	PW (TSSOP)	DBQ (SSOP)	DB (SSOP)	DW (SOIC)		
	16 PINS	16 PINS	16 PINS	16 PINS		
R _{θJA}	Junction-to-ambient thermal resistance	122	121.7	113.2	84.7	°C/W
R _{θJC(top)}	Junction-to-case (top) thermal resistance	56.4	72.9	63.6	48	°C/W
R _{θJB}	Junction-to-board thermal resistance	67.1	64.2	64	49.1	°C/W
Ψ _{JT}	Junction-to-top characterization parameter	10.8	24.4	21.2	22.7	°C/W
Ψ _{JB}	Junction-to-board characterization parameter	66.5	63.8	63.4	48.7	°C/W

(1) For more information about traditional and new thermal metrics, see the [Semiconductor and IC Package Thermal Metrics](#) application report.

6.5 Electrical Characteristics

over operating free-air temperature range (unless otherwise noted)

PARAMETER		TEST CONDITIONS	V _{CC}	MIN	TYP ⁽¹⁾	MAX	UNIT
V _{IK}	Input diode clamp voltage	I _I = -18 mA	1.65 V to 5.5 V	-1.2			V
V _{PORR}	Power-on reset voltage, V _{CC} rising	V _I = V _{CC} or GND, I _O = 0			1.2	1.5	V
V _{PORF}	Power-on reset voltage, V _{CC} falling	V _I = V _{CC} or GND, I _O = 0		0.75	1		V
V _{OH}	P-port high-level output voltage ⁽²⁾	I _{OH} = -8 mA	1.65 V	1.2			V
			2.3 V	1.8			
			3 V	2.6			
			4.5 V	4.1			
		I _{OH} = -10 mA	1.65 V	1.1			
			2.3 V	1.7			
			3 V	2.5			
			4.5 V	4			
I _{OL}	SDA ⁽³⁾	V _{OL} = 0.4 V	1.65 V to 5.5 V	3	11		mA
			1.65 V	8	10		
	P port ⁽⁴⁾	V _{OL} = 0.5 V	2.3 V	8	13		
			3 V	8	15		
			4.5 V	8	17		
			1.65 V	10	14		
			2.3 V	10	17		
			3 V	10	20		
	P port ⁽⁴⁾	V _{OL} = 0.7 V	3 V	10	20		
			4.5 V	10	24		
I _{OL}	INT ⁽⁵⁾	V _{OL} = 0.4 V	1.65 V to 5.5 V	3	7		
I _I	SCL, SDA	V _I = V _{CC} or GND	1.65 V to 5.5 V			±1	μA
	A0, A1, A2					±1	
I _{IH}	P port	V _I = V _{CC}	1.65 V to 5.5 V			1	μA
I _{IL}	P port	V _I = GND	1.65 V to 5.5 V			-100	μA

(1) All typical values are at nominal supply voltage (1.8-, 2.5-, 3.3-, or 5-V V_{CC}) and T_A = 25°C.

(2) Each P-port I/O configured as a high output must be externally limited to a maximum of 10 mA, and the total current sourced by all I/Os (P-ports P7-P0) through V_{CC} must be limited to a maximum current of 80 mA.

(3) The SDA pin must be externally limited to a maximum of 12 mA, and the total current sunk by all I/Os (P-ports P7-P0, INT, and SDA) through GND must be limited to a maximum current of 200 mA.

(4) Each P-port I/O configured as a low output must be externally limited to a maximum of 25 mA, and the total current sunk by all I/Os (P-ports P7-P0, INT, and SDA) through GND must be limited to a maximum current of 200 mA.

(5) The INT pin must be externally limited to a maximum of 7 mA, and the total current sunk by all I/Os (P-ports P7-P0, INT, and SDA) through GND must be limited to a maximum current of 200 mA.

Electrical Characteristics (continued)

over operating free-air temperature range (unless otherwise noted)

PARAMETER		TEST CONDITIONS		V _{CC}	MIN	TYP ⁽¹⁾	MAX	UNIT
I _{CC}	Operating mode	V _I = V _{CC} or GND, I _O = 0, I/O = inputs, f _{SCL} = 400 kHz, no load, t _{r,max} = 300 ns		5.5 V		34		μA
				3.6 V		15		
				2.7 V		9		
				1.65 V		5		
	Standby mode	I/O = inputs, f _{SCL} = 0 kHz	V _I = V _{CC}	5.5 V	1.9	3.5		
				3.6 V	1.1	1.8		
				2.7 V	1	1.6		
			V _I = GND	1.95 V	0.4	1		
				5.5 V	0.45	0.7		
				3.6 V	0.3	0.6		
C _i	SCL	V _I = V _{CC} or GND		1.65 V to 5.5 V		3	8	pF
C _{io}	SDA	V _{IO} = V _{CC} or GND		1.65 V to 5.5 V		5.5	9.5	pF
	P port					8	9.5	

6.6 I²C Interface Timing Requirements

over operating free-air temperature range (unless otherwise noted) (see [Figure 11](#))

		MIN	MAX	UNIT	
STANDARD MODE					
f _{scl}	I ² C clock frequency	0	100	kHz	
t _{sch}	I ² C clock high time	4		μs	
t _{scl}	I ² C clock low time	4.7		μs	
t _{sp}	I ² C spike time		50	ns	
t _{sds}	I ² C serial-data setup time	250		ns	
t _{sdh}	I ² C serial-data hold time	0		ns	
t _{icr}	I ² C input rise time		1000	ns	
t _{icf}	I ² C input fall time		300	ns	
t _{ocf}	I ² C output fall time	10-pF to 400-pF bus	300	ns	
t _{buf}	I ² C bus free time between Stop and Start	4.7		μs	
t _{sts}	I ² C Start or repeated Start condition setup	4.7		μs	
t _{sth}	I ² C Start or repeated Start condition hold	4		μs	
t _{sps}	I ² C Stop condition setup	4		μs	
t _{vd(data)}	Valid data time	SCL low to SDA output valid	3.45	μs	
t _{vd(ack)}	Valid data time of ACK condition	ACK signal from SCL low to SDA (out) low	3.45	μs	
C _b	I ² C bus capacitive load		400	pF	
FAST MODE					
f _{scl}	I ² C clock frequency	0	400	kHz	
t _{sch}	I ² C clock high time	0.6		μs	
t _{scl}	I ² C clock low time	1.3		μs	
t _{sp}	I ² C spike time		50	ns	
t _{sds}	I ² C serial-data setup time	100		ns	
t _{sdh}	I ² C serial-data hold time	0		ns	
t _{icr}	I ² C input rise time	20	300	ns	
t _{icf}	I ² C input fall time	20 × (V _{DD} / 5.5 V)	300	ns	
t _{ocf}	I ² C output fall time	10-pF to 400-pF bus	20 × (V _{DD} / 5.5 V)	300	ns
t _{buf}	I ² C bus free time between Stop and Start	1.3		μs	
t _{sts}	I ² C Start or repeated Start condition setup	0.6		μs	
t _{sth}	I ² C Start or repeated Start condition hold	0.6		μs	
t _{sps}	I ² C Stop condition setup	0.6		μs	
t _{vd(data)}	Valid data time		0.9	μs	
t _{vd(ack)}	Valid data time of ACK condition		0.9	μs	
C _b	I ² C bus capacitive load		400	pF	

6.7 Switching Characteristics

over operating free-air temperature range (unless otherwise noted) (see [Figure 12](#) and [Figure 13](#))

PARAMETER	FROM (INPUT)	TO (OUTPUT)	MIN	MAX	UNIT
STANDARD MODE and FAST MODE					
t _{iv}	Interrupt valid time	P port		4	μs
t _{ir}	Interrupt reset delay time	SCL		4	μs
t _{pv}	Output data valid	SCL		350	ns
t _{ps}	Input data setup time	P port	100		ns
t _{ph}	Input data hold time	P port	1		μs

6.8 Typical Characteristics

T_A = 25°C (unless otherwise noted)

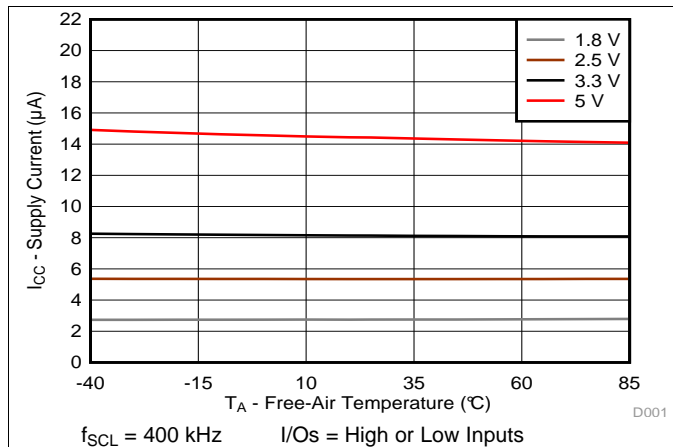

Figure 1. Supply Current (I_{CC}, Operating Mode) vs Temperature (T_A) at Four Supply Voltages

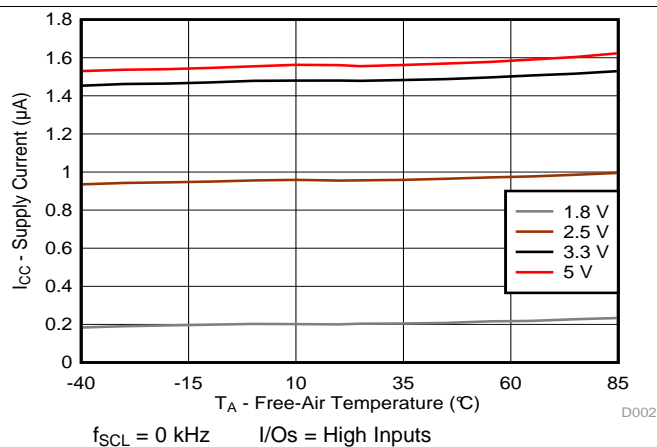

Figure 2. Supply Current (I_{CC}, Standby Mode) vs Temperature (T_A) at Four Supply Voltages

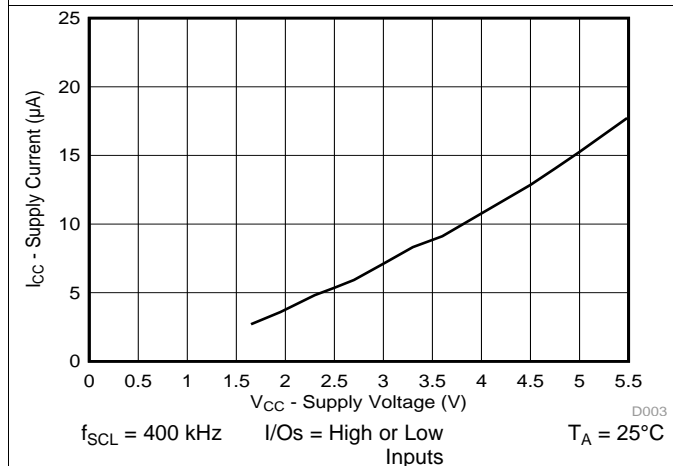

Figure 3. Supply Current (I_{CC}, Operating Mode) vs Supply Voltage (V_{CC})

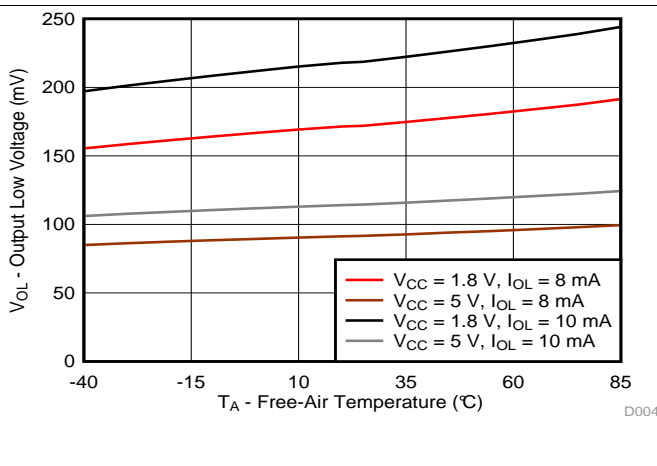

Figure 4. Output Low Voltage (V_{OL}) vs Temperature (T_A) for P-Port I/Os

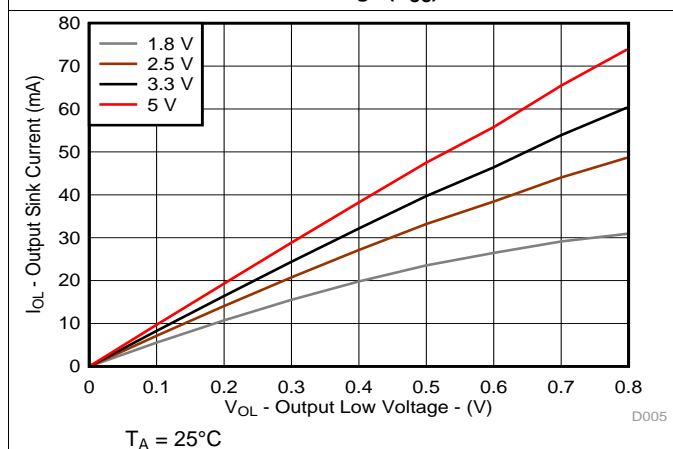

Figure 5. Sink Current (I_{OL}) vs Output Low Voltage (V_{OL}) for P-Ports at Four Supply Voltages

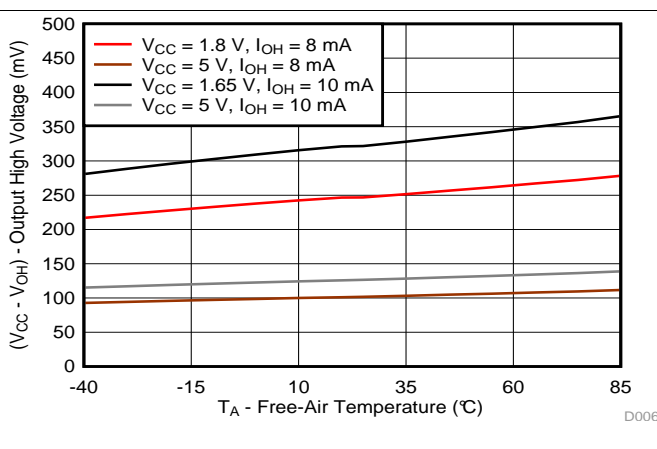

Figure 6. Output High Voltage (V_{CC} - V_{OH}) vs Temperature (T_A) for P-Ports

Typical Characteristics (continued)

$T_A = 25^\circ\text{C}$ (unless otherwise noted)

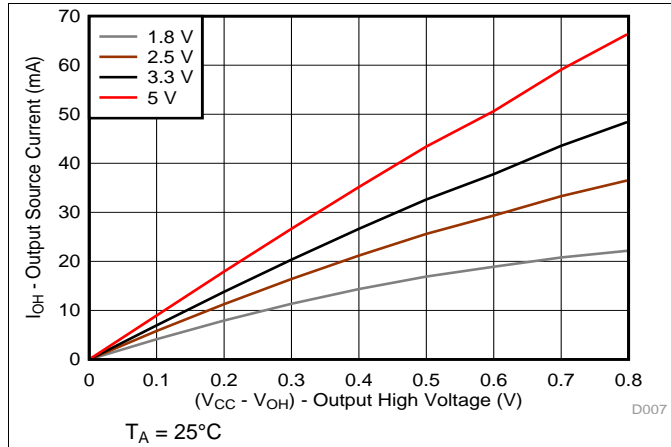

Figure 7. Source Current (I_{OH}) vs Output High Voltage (V_{OH}) for P-Ports at Four Supply Voltages

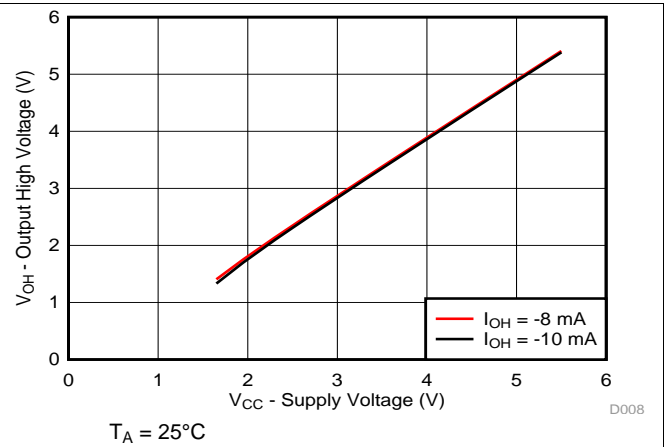

Figure 8. Output High Voltage (V_{OH}) vs Supply Voltage (V_{CC}) for P-Ports

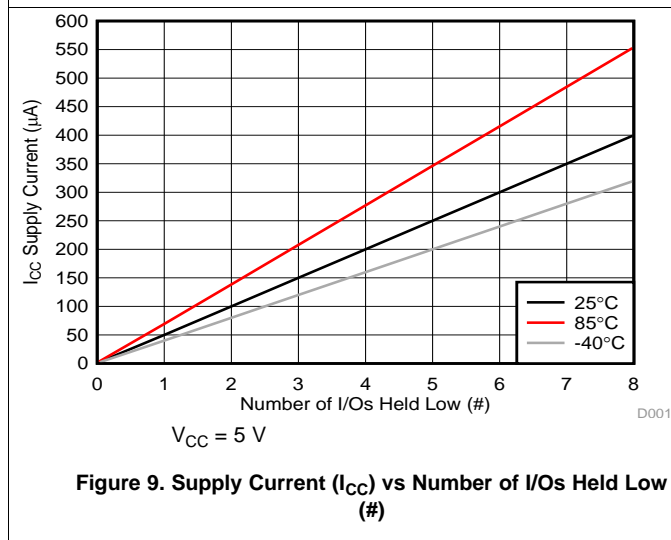

Figure 9. Supply Current (I_{CC}) vs Number of I/Os Held Low (#)

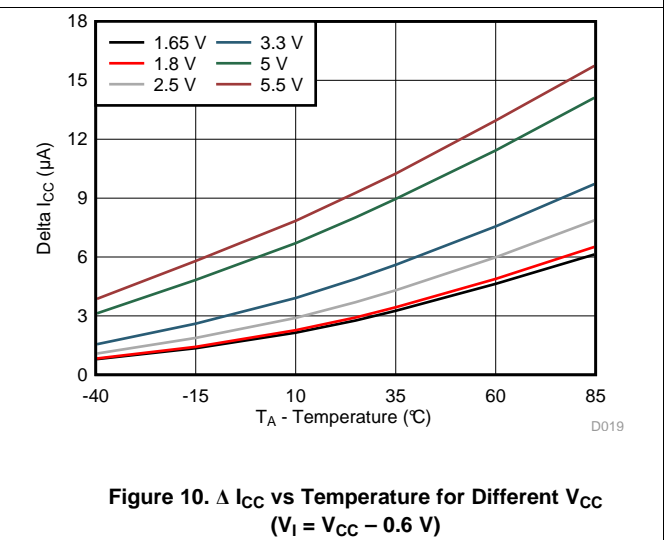
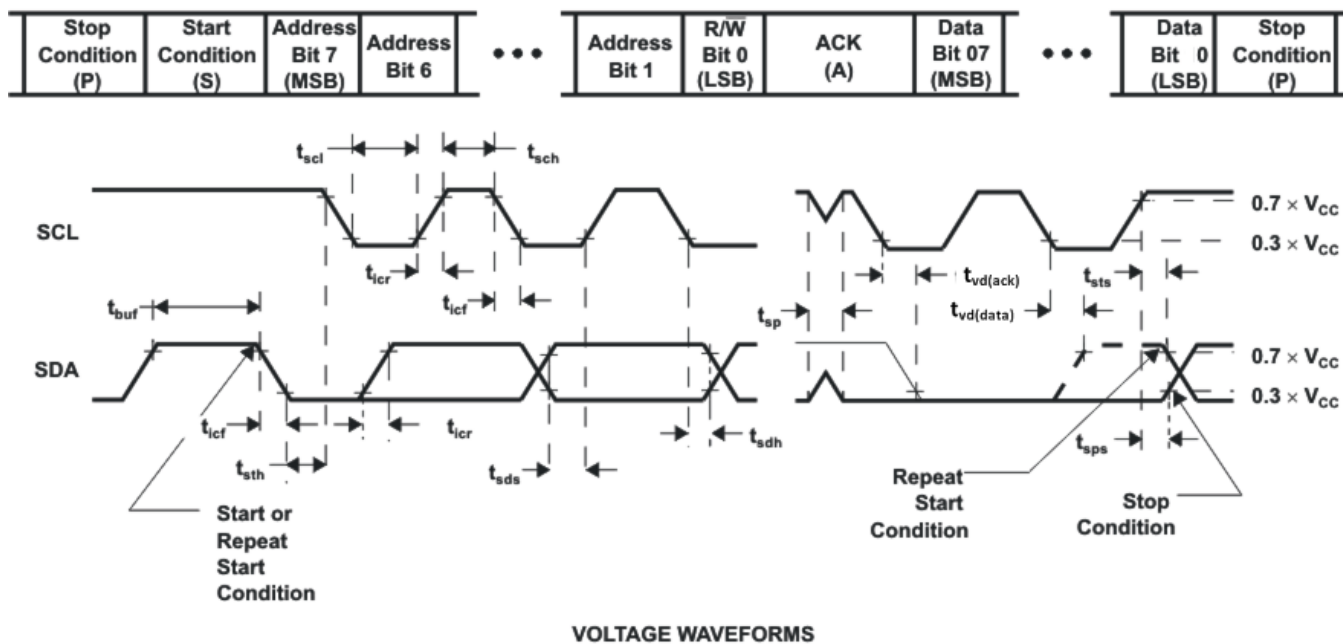
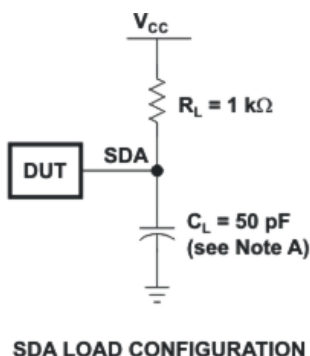

Figure 10. ΔI_{CC} vs Temperature for Different V_{CC} ($V_I = V_{CC} - 0.6\text{ V}$)

7 Parameter Measurement Information



BYTE	DESCRIPTION
1	I ² C address
2, 3	P-port data

- A. C_L includes probe and jig capacitance.
- B. All inputs are supplied by generators having the following characteristics: PRR ≤ 10 MHz, Z_O = 50 Ω, t_r/t_f ≤ 30 ns.
- C. All parameters and waveforms are not applicable to all devices.

Figure 11. I²C Interface Load Circuit and Voltage Waveforms

Parameter Measurement Information (continued)

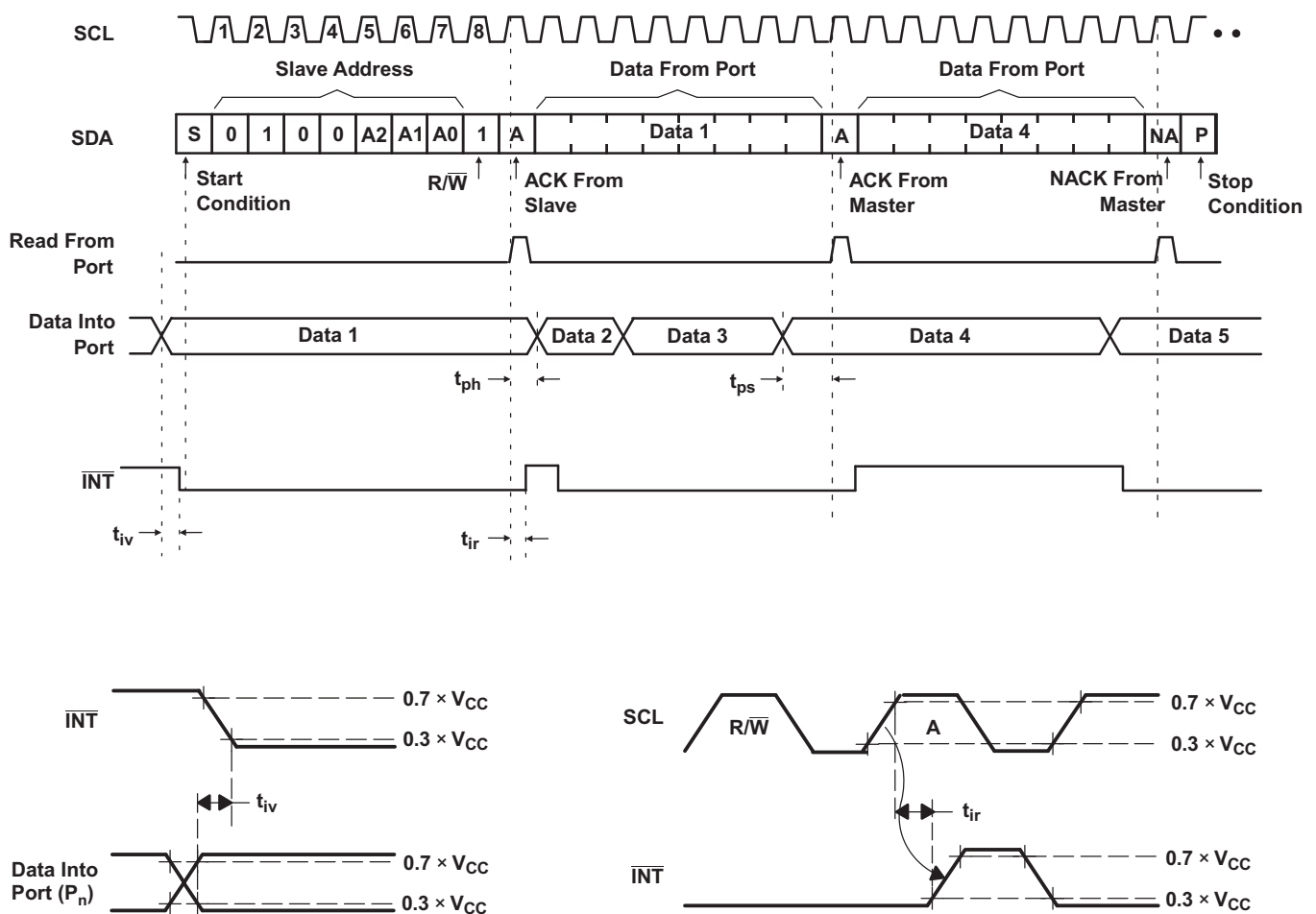
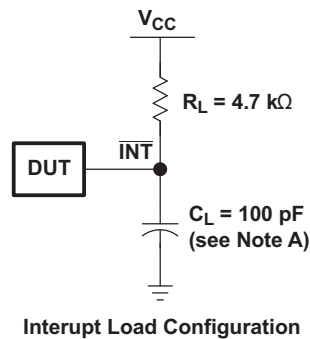

- A. C_L includes probe and jig capacitance.
- B. All inputs are supplied by generators having the following characteristics: $PRR \leq 10$ MHz, $Z_O = 50 \Omega$, $t_r/t_f \leq 30$ ns.
- C. All parameters and waveforms are not applicable to all devices.

Figure 12. Interrupt Load Circuit and Voltage Waveforms

Parameter Measurement Information (continued)

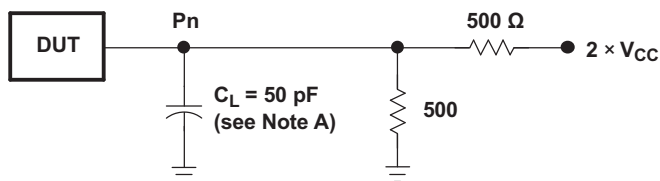

P-Port Load Configuration

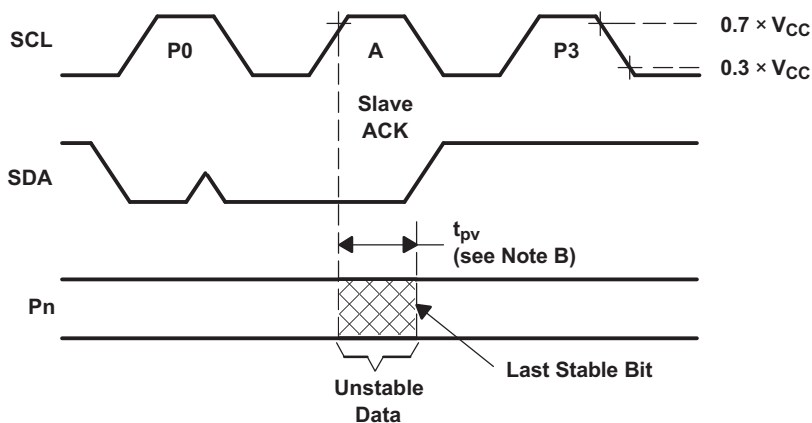

Write Mode ($R/\bar{W} = 0$)

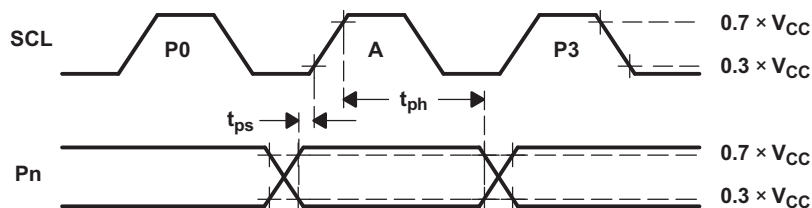

Read Mode ($R/\bar{W} = 1$)

- A. C_L includes probe and jig capacitance.
- B. t_{pv} is measured from $0.7 \times V_{CC}$ on SCL to 50% I/O (Pn) output.
- C. All inputs are supplied by generators having the following characteristics: PRR \leq 10 MHz, $Z_O = 50 \Omega$, $t_r/t_f \leq 30$ ns.
- D. The outputs are measured one at a time, with one transition per measurement.
- E. All parameters and waveforms are not applicable to all devices.

Figure 13. P-Port Load Circuit and Voltage Waveforms

8 Detailed Description

8.1 Overview

The TCA9554 is an 8-bit I/O expander for the two-line bidirectional bus (I²C) is designed for 1.65-V to 5.5-V V_{CC} operation. It provides general-purpose remote I/O expansion for most micro-controller families via the I²C interface (serial clock, SCL, and serial data, SDA, pins).

The TCA9554 open-drain interrupt (\overline{INT}) output is activated when any input state differs from its corresponding Input Port register state and is used to indicate to the system master that an input state has changed. The \overline{INT} pin can be connected to the interrupt input of a micro-controller. By sending an interrupt signal on this line, the remote I/O can inform the micro-controller if there is incoming data on its ports without having to communicate via the I²C bus. Thus, the TCA9554 can remain a simple slave device. The device outputs (latched) have high-current drive capability for directly driving LEDs.

Three hardware pins (A0, A1, and A2) are used to program and vary the fixed I²C slave address and allow up to eight devices to share the same I²C bus or SMBus.

The system master can reset the TCA9554 in the event of a timeout or other improper operation by cycling the power supply and causing a power-on reset (POR). A reset puts the registers in their default state and initializes the I²C /SMBus state machine.

The TCA9554 consists of one 8-bit Configuration (input or output selection), Input Port, Output Port, and Polarity Inversion (active high or active low) registers. At power on, the I/Os are configured as inputs. However, the system master can enable the I/Os as either inputs or outputs by writing to the I/O configuration bits. The data for each input or output is kept in the corresponding Input Port or Output Port register. The polarity of the Input Port register can be inverted with the Polarity Inversion register. All registers can be read by the system master.

The TCA9554 and TCA9554A are identical except for their fixed I²C address. This allows for up to 16 of these devices (8 of each) on the same I²C/SMBus.

The TCA9554 is identical to the TCA9534 except for the addition of the internal I/O pull-up resistors, which keeps P-ports from floating when configured as inputs.

8.2 Functional Block Diagram

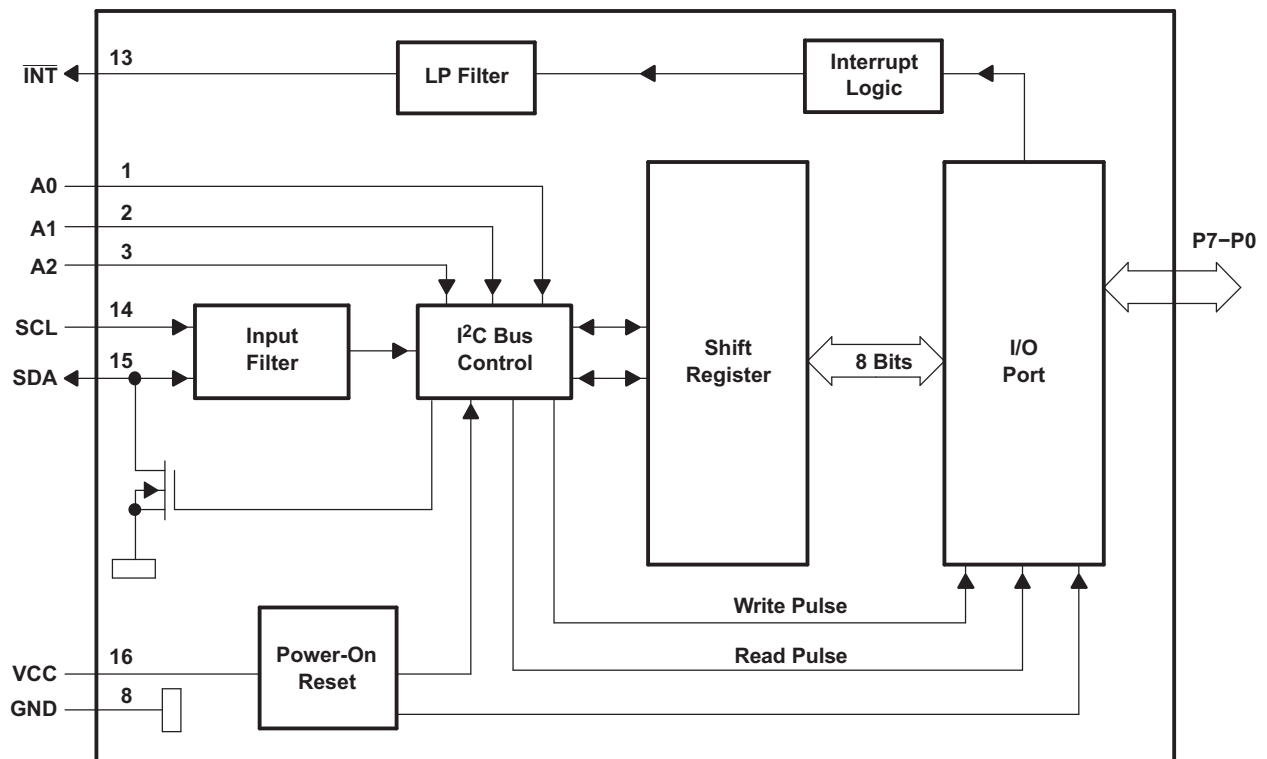

Pin numbers shown are for the PW package.

Figure 14. Functional Block Diagram

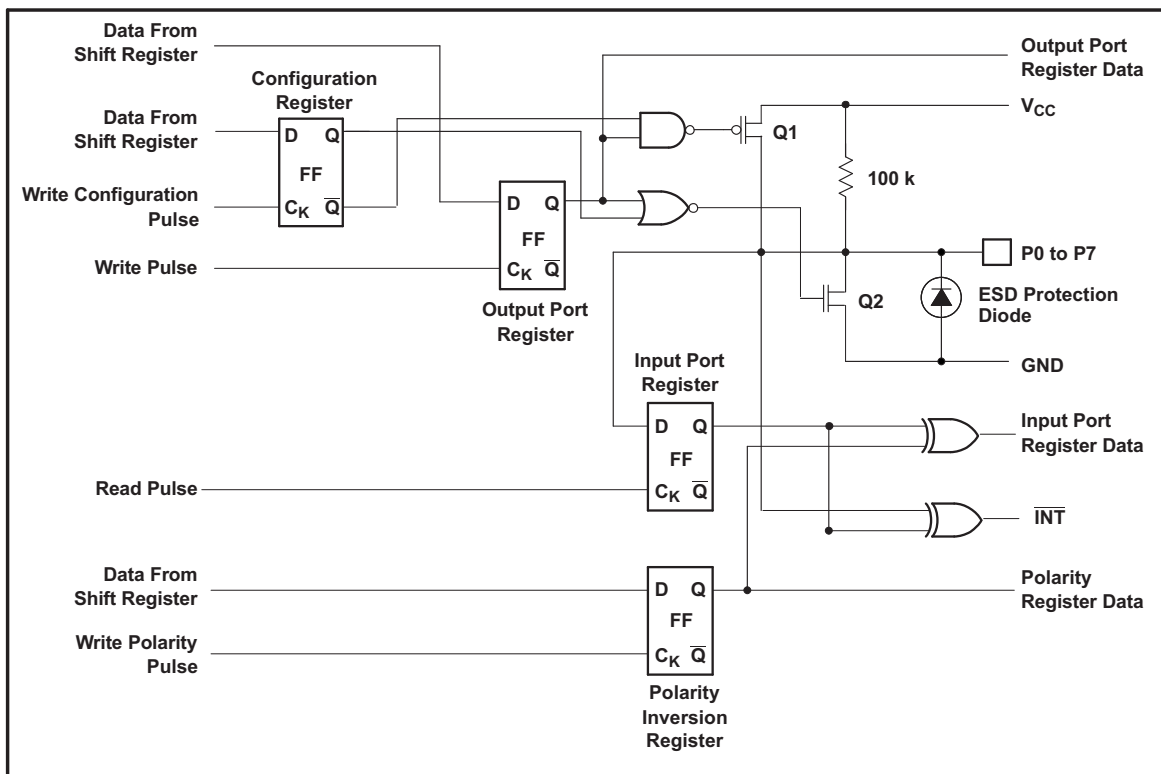
Functional Block Diagram (continued)

At power-on reset, all registers return to default values.

Figure 15. Simplified Schematic Of P0 To P7

8.3 Feature Description

8.3.1 I/O Port

When an I/O is configured as an input, FETs Q1 and Q2 are off, creating a high-impedance input with a weak pull-up (100 kΩ typical) to V_{CC}. The input voltage may be raised above V_{CC} to a maximum of 5.5 V, however it must be noted that because of the integrated 100 kΩ pull-up resistor it may result in current flow from I/O to V_{CC} pin (Figure 15).

If the I/O is configured as an output, Q1 or Q2 is enabled depending on the state of the output port register. In this case, there are low impedance paths between the I/O pin and either V_{CC} or GND. The external voltage applied to this I/O pin must not exceed the recommended levels for proper operation.

8.3.2 Interrupt Output (\bar{INT})

An interrupt is generated by any rising or falling edge of any P-port I/O configured as an input. After time t_{iv} , the signal \bar{INT} is valid. Resetting the interrupt circuit is achieved when data on the ports is changed back to the original state or when data is read from the Input Port register. Resetting occurs in the read mode at the acknowledge (ACK) bit after the rising edge of the SCL signal. Interrupts that occur during the ACK clock pulse can be lost (or be very short) due to the resetting of the interrupt during this pulse. Each change of the I/Os after resetting is detected and is transmitted as an interrupt on the \bar{INT} pin.

Reading from or writing to another device does not affect the interrupt circuit, and a pin configured as an output cannot cause an interrupt. Changing an I/O from an output to an input may cause a false interrupt to occur if the state of the pin does not match the contents of the Input Port register.

The \bar{INT} output has an open-drain structure and requires pull-up resistor to V_{CC}.

8.4 Device Functional Modes

8.4.1 Power-On Reset

When power (from 0 V) is applied to VCC, an internal power-on reset holds the TCA9554 in a reset condition until VCC has reached V_{PORR}. At that point, the reset condition is released and the TCA9554 registers and SMBus/I²C state machine initializes to their default states. After that, VCC must be lowered to below V_{PORF} and then back up to the operating voltage for a power-on reset cycle.

8.5 Programming

8.5.1 I²C Interface

The bidirectional I²C bus consists of the serial clock (SCL) and serial data (SDA) lines. Both lines must be connected to a positive supply through a pull-up resistor when connected to the output stages of a device. Data transfer may be initiated only when the bus is not busy.

I²C communication with this device is initiated by a master sending a Start condition, a high-to-low transition on the SDA input-output while the SCL input is high (see Figure 16). After the Start condition, the device address byte is sent, most significant bit (MSB) first, including the data direction bit (R/W).

After receiving the valid address byte, this device responds with an acknowledge (ACK), a low on the SDA input/output during the high of the ACK-related clock pulse. The address inputs (A0–A2) of the slave device must not be changed between the Start and the Stop conditions.

On the I²C bus, only one data bit is transferred during each clock pulse. The data on the SDA line must remain stable during the high pulse of the clock period, as changes in the data line at this time are interpreted as control commands (Start or Stop) (see Figure 17).

A Stop condition, a low-to-high transition on the SDA input/output while the SCL input is high, is sent by the master (see Figure 16).

Any number of data bytes can be transferred from the transmitter to receiver between the Start and the Stop conditions. Each byte of eight bits is followed by one ACK bit. The transmitter must release the SDA line before the receiver can send an ACK bit. The device that acknowledges must pull down the SDA line during the ACK clock pulse so that the SDA line is stable low during the high pulse of the ACK-related clock period (see Figure 18). When a slave receiver is addressed, it must generate an ACK after each byte is received. Similarly, the master must generate an ACK after each byte that it receives from the slave transmitter. Setup and hold times must be met to ensure proper operation.

A master receiver signals an end of data to the slave transmitter by not generating an acknowledge (NACK) after the last byte has been clocked out of the slave. This is done by the master receiver by holding the SDA line high. In this event, the transmitter must release the data line to enable the master to generate a Stop condition.

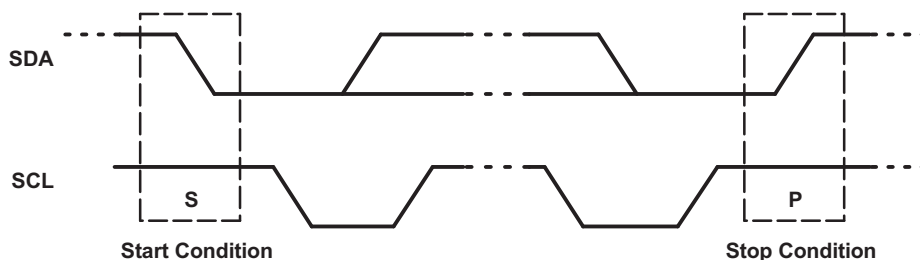

Figure 16. Definition of Start and Stop Conditions

Programming (continued)

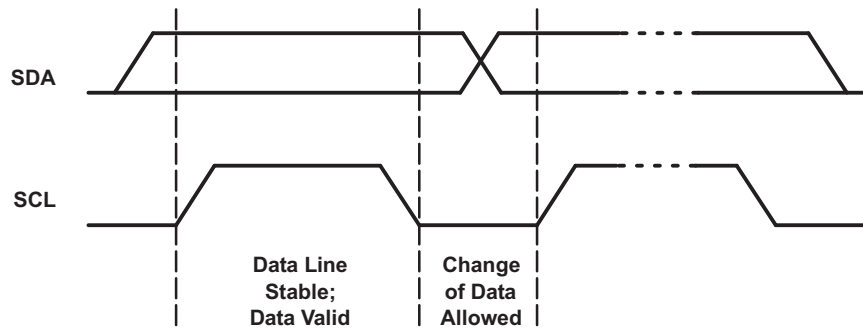

Figure 17. Bit Transfer

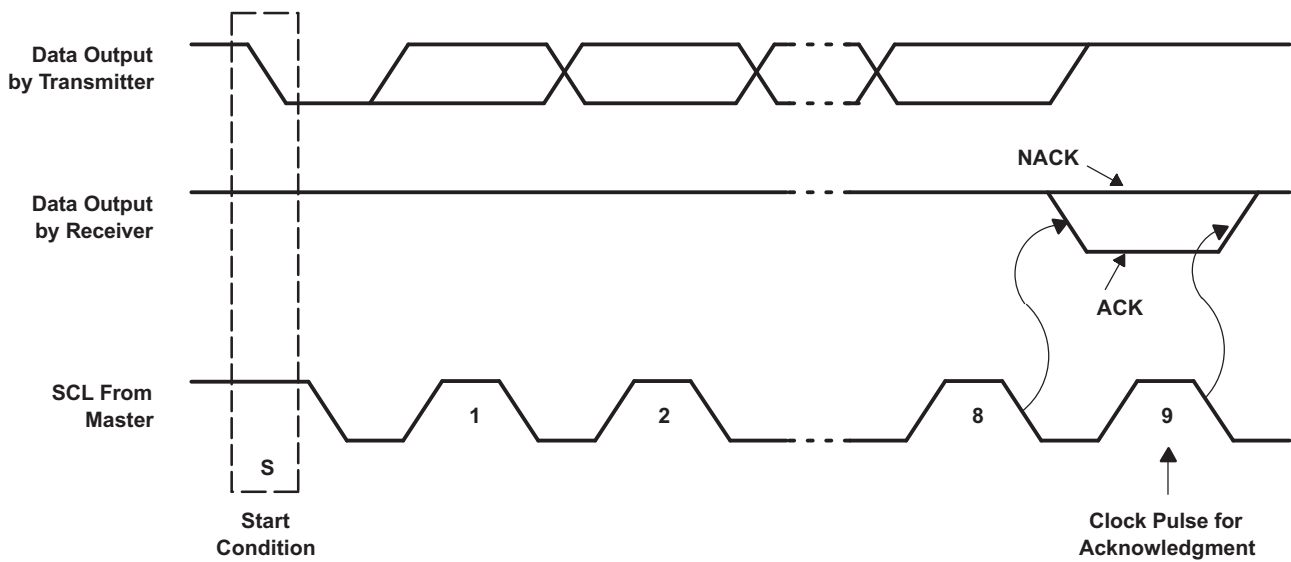

Figure 18. Acknowledgment on I²C Bus

Table 1 shows the TCA9554 interface definition.

Table 1. Interface Definition Table

BYTE	BIT							
	7 (MSB)	6	5	4	3	2	1	0 (LSB)
I ² C slave address	L	H	L	L	A2	A1	A0	R/W
Px I/O data bus	P7	P6	P5	P4	P3	P2	P1	P0

8.6 Register Maps

8.6.1 Device Address

Figure 19 shows the address byte of the TCA9554.

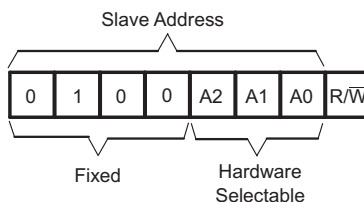

Figure 19. TCA9554 Address

Table 2 shows the TCA9554 address reference.

Table 2. Address Reference

INPUTS			I ² C BUS SLAVE ADDRESS
A2	A1	A0	
L	L	L	32 (decimal), 20 (hexadecimal)
L	L	H	33 (decimal), 21 (hexadecimal)
L	H	L	34 (decimal), 22 (hexadecimal)
L	H	H	35 (decimal), 23 (hexadecimal)
H	L	L	36 (decimal), 24 (hexadecimal)
H	L	H	37 (decimal), 25 (hexadecimal)
H	H	L	38 (decimal), 26 (hexadecimal)
H	H	H	39 (decimal), 27 (hexadecimal)

The last bit of the slave address defines the operation (read or write) to be performed. When it is high (1), a read is selected, while a low (0) selects a write operation.

8.6.2 Control Register and Command Byte

Following the successful Acknowledgment of the address byte, the bus master sends a command byte that is stored in the control register in the TCA9554 (see Figure 20). Two bits of this command byte state the operation (read or write) and the internal register (input, output, polarity inversion or configuration) that is affected. This register can be written or read through the I²C bus. The command byte is sent only during a write transmission.

Once a command byte has been sent, the register that was addressed continues to be accessed by reads until a new command byte has been sent.

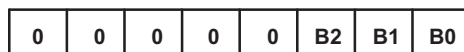

Figure 20. Control Register Bits

Table 3 shows the TCA9554 command byte.

Table 3. Command Byte Table

CONTROL REGISTER BITS		COMMAND BYTE (HEX)	REGISTER	PROTOCOL	POWER-UP DEFAULT
B1	B0				
0	0	0x00	Input Port	Read byte	XXXX XXXX
0	1	0x01	Output Port	Read-write byte	1111 1111
1	0	0x02	Polarity Inversion	Read-write byte	0000 0000
1	1	0x03	Configuration	Read-write byte	1111 1111

8.6.3 Register Descriptions

The Input Port register (register 0) reflects the incoming logic levels of the pins, regardless of whether the pin is defined as an input or an output by the Configuration register. It only acts on read operation. Writes to these registers have no effect. The default value, X, is determined by the externally applied logic level.

Before a read operation, a write transmission is sent with the command byte to indicate to the I²C device that the Input Port register is accessed next. See Table 4.

Table 4. Register 0 (Input Port Register) Table

BIT	I7	I6	I5	I4	I3	I2	I1	I0
DEFAULT	X	X	X	X	X	X	X	X

The Output Port register (register 1) shows the outgoing logic levels of the pins defined as outputs by the Configuration register. Bit values in this register have no effect on pins defined as inputs. In turn, reads from this register reflect the value that is in the flip-flop controlling the output selection, not the actual pin value. See Table 5.

Table 5. Register 1 (Output Port Register) Table

BIT	O7	O6	O5	O4	O3	O2	O1	O0
DEFAULT	1	1	1	1	1	1	1	1

The Polarity Inversion register (register 2) allows polarity inversion of pins defined as inputs by the Configuration register. If a bit in this register is set (written with 1), the corresponding port pin polarity is inverted. If a bit in this register is cleared (written with a 0), the corresponding port pin original polarity is retained. See Table 6.

Table 6. Register 2 (Polarity Inversion Register) Table

BIT	N7	N6	N5	N4	N3	N2	N1	N0
DEFAULT	0	0	0	0	0	0	0	0

The Configuration register (register 3) configures the directions of the I/O pins. If a bit in this register is set to 1, the corresponding port pin is enabled as an input with a high-impedance output driver. If a bit in this register is cleared to 0, the corresponding port pin is enabled as an output. See Table 7.

Table 7. Register 3 (Configuration Register) Table

BIT	C7	C6	C5	C4	C3	C2	C1	C0
DEFAULT	1	1	1	1	1	1	1	1

8.6.3.1 Bus Transactions

Data is exchanged between the master and the TCA9554 through write and read commands.

8.6.3.1.1 Writes

To write on the I²C bus, the master sends a START condition on the bus with the address of the slave, as well as the last bit (the R/W bit) set to 0, which signifies a write. After the slave sends the acknowledge bit, the master then sends the register address of the register to which it wishes to write. The slave acknowledges again, letting the master know it is ready. After this, the master starts sending the register data to the slave until the master has sent all the data necessary (which is sometimes only a single byte), and the master terminates the transmission with a STOP condition. Note that the command byte/register address does NOT automatically increment. Writing multiple bytes during a write results in the last byte sent being stored in the register.

See the [Register Descriptions](#) section to see list of the TCA9554's internal registers and a description of each one.

Figure 21 shows an example of writing a single byte to a slave register.

- Master controls SDA line
- Slave controls SDA line

Write to one register in a device

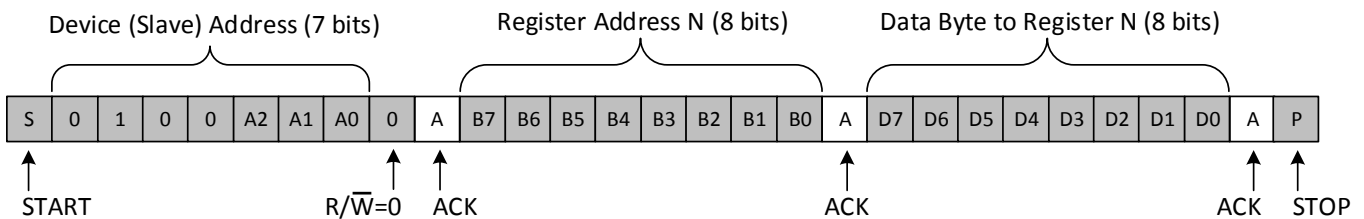

Figure 21. Write to Register

Figure 22 shows an example of how to write to the polarity inversion register.

- Master controls SDA line
- Slave controls SDA line

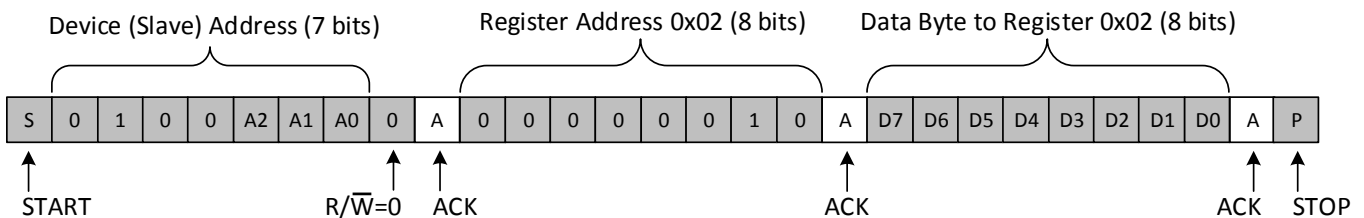

Figure 22. Write to the Polarity Inversion Register

Figure 23 shows an example of how to write to output port register.

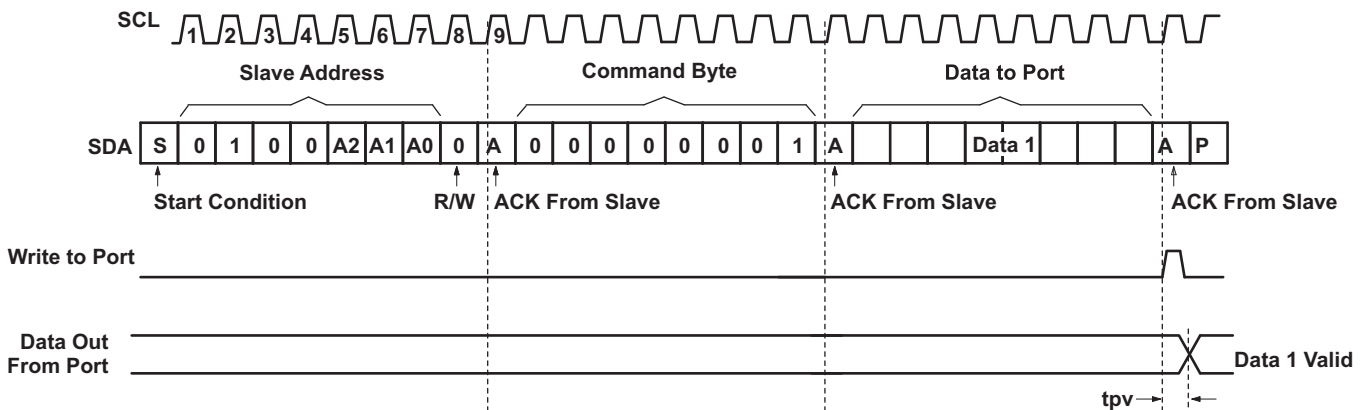

Figure 23. Write to Output Port Register

8.6.3.1.2 Reads

The bus master first must send the TCA9554 address with the LSB set to a logic 0 (see Figure 19 for device address). The command byte is sent after the address and determines which register is accessed. After a restart, the device address is sent again but, this time, the LSB is set to a logic 1. Data from the register defined by the command byte then is sent by the TCA9554 (see Figure 25). The command byte does not increment automatically. If multiple bytes are read, data from the specified command byte/register is going to be continuously read.

See the [Register Descriptions](#) section for the list of the TCA9554's internal registers and a description of each one.

Figure 24 shows an example of reading a single byte from a slave register.

Master controls SDA line

Slave controls SDA line

Read from one register in a device

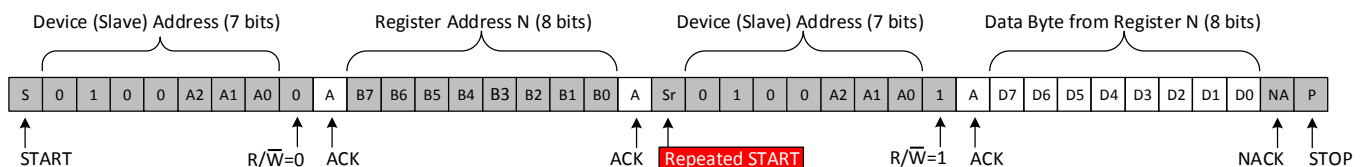
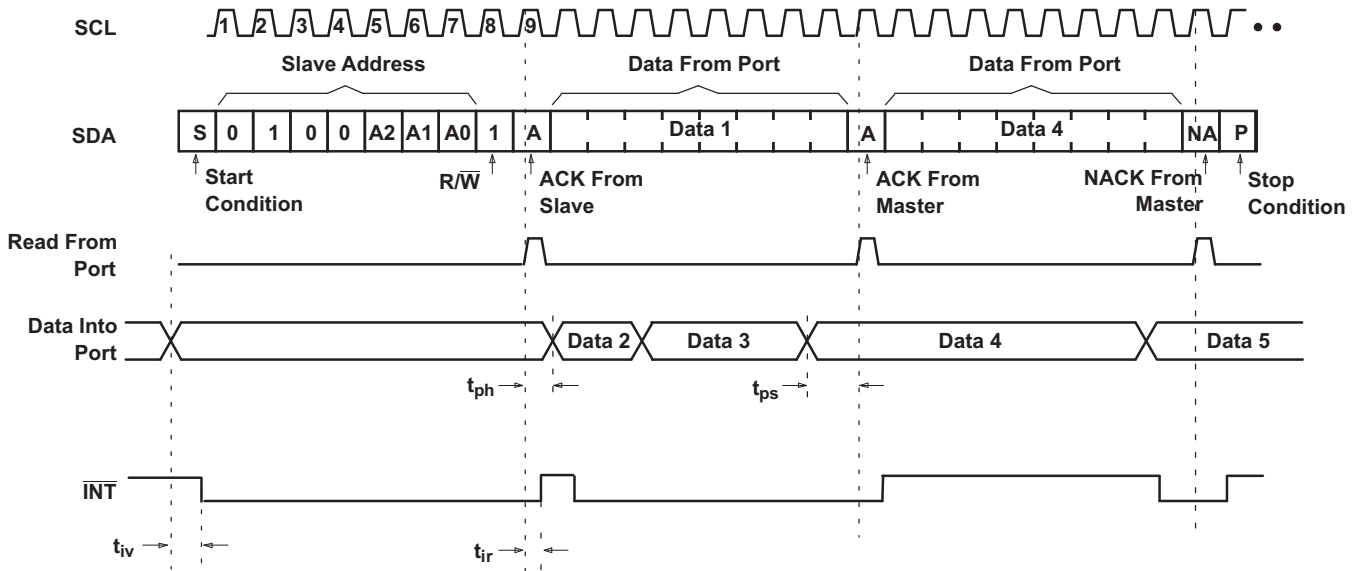

Figure 24. Read from Register

After a restart, the value of the register defined by the command byte matches the register being accessed when the restart occurred. Data is clocked into the register on the rising edge of the ACK clock pulse. After the first byte, additional bytes may be read, but the same register specified by the command byte is read.

Data is clocked into the register on the rising edge of the ACK clock pulse. There is no limitation on the number of data bytes received in one read transmission, but when the final byte is received, the bus master must not acknowledge the data.



- A. Transfer of data can be stopped at any time by a Stop condition. When this occurs, data present at the latest acknowledge phase is valid (output mode). It is assumed that the command byte previously has been set to 00 (Read Input Port register).
- B. This figure eliminates the command byte transfer, a restart, and slave address call between the initial slave address call and actual data transfer from the P port (see [Figure 24](#) for these details).

Figure 25. Read Input Port Register

9 Application and Implementation

NOTE

Information in the following applications sections is not part of the TI component specification, and TI does not warrant its accuracy or completeness. TI's customers are responsible for determining suitability of components for their purposes. Customers should validate and test their design implementation to confirm system functionality.

9.1 Application Information

Applications of the TCA9554 has this device connected as a slave to an I²C master (processor), and the I²C bus may contain any number of other slave devices. The TCA9554 is typically in a remote location from the master, placed close to the GPIOs to which the master must monitor or control.

IO Expanders such as the TCA9554 are typically used for controlling LEDs (for feedback or status lights), controlling enable or reset signals of other devices, and even reading the outputs of other devices or buttons.

9.2 Typical Application

Figure 26 shows an application in which the TCA9554 can be used.

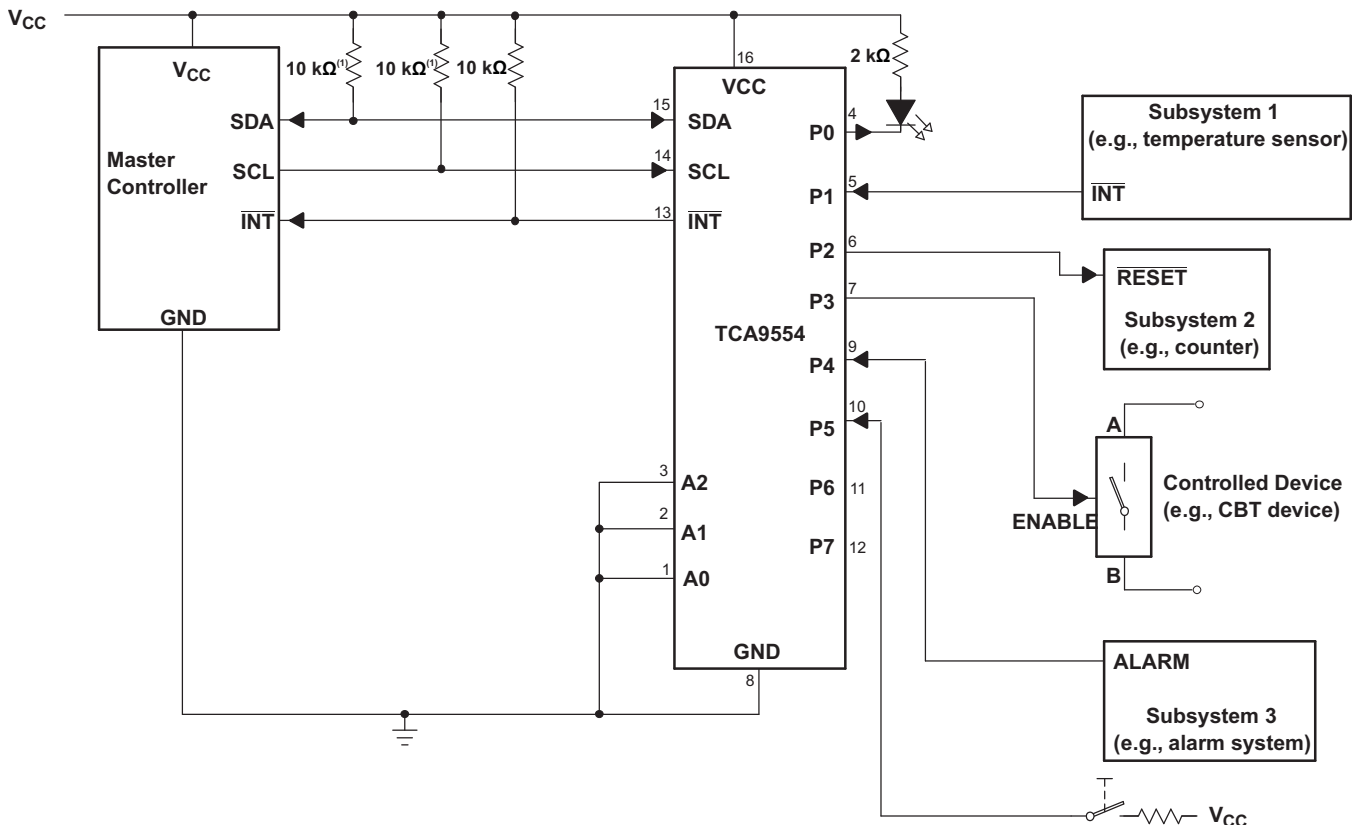

- (1) The SCL and SDA pins must be tied directly to VCC because if SCL and SDA are tied to an auxiliary power supply that can be powered on while VCC is powered off, then the supply current, ICC, will increase as a result.
- (2) Device address is configured as 0100000 for this example.
- (3) P0, P2, and P3 are configured as outputs.
- (4) P1, P4, and P5 are configured as inputs.
- (5) P6 and P7 are not used and have internal 100-kΩ pullup resistors to protect them from floating.

Figure 26. Application Schematic

Typical Application (continued)

9.2.1 Design Requirements

9.2.1.1 Calculating Junction Temperature and Power Dissipation

When designing with this device, it is important that the *Recommended Operating Conditions* not be violated. Many of the parameters of this device are rated based on junction temperature. So junction temperature must be calculated in order to verify that safe operation of the device is met. The basic equation for junction temperature is shown in Equation 1.

$$T_j = T_A + (\theta_{JA} \times P_d) \quad (1)$$

θ_{JA} is the standard junction to ambient thermal resistance measurement of the package, as seen in *Thermal Information* table. P_d is the total power dissipation of the device, and the approximation is shown in Equation 2.

$$P_d \approx (I_{CC_STATIC} \times V_{CC}) + \sum P_{d_PORT_L} + \sum P_{d_PORT_H} \quad (2)$$

Equation 2 is the approximation of power dissipation in the device. The equation is the static power plus the summation of power dissipated by each port (with a different equation based on if the port is outputting high, or outputting low. If the port is set as an input, then power dissipation is the input leakage of the pin multiplied by the voltage on the pin). Note that this ignores power dissipation in the \overline{INT} and SDA pins, assuming these transients to be small. They can easily be included in the power dissipation calculation by using Equation 3 to calculate the power dissipation in \overline{INT} or SDA while they are pulling low, and this gives maximum power dissipation.

$$P_{d_PORT_L} = (I_{OL} \times V_{OL}) \quad (3)$$

Equation 3 shows the power dissipation for a single port which is set to output low. The power dissipated by the port is the V_{OL} of the port multiplied by the current it is sinking.

$$P_{d_PORT_H} = (I_{OH} \times (V_{CC} - V_{OH})) \quad (4)$$

Equation 4 shows the power dissipation for a single port which is set to output high. The power dissipated by the port is the current sourced by the port multiplied by the voltage drop across the device (difference between V_{CC} and the output voltage).

9.2.1.2 Minimizing I_{CC} when I/Os Control LEDs

When the I/Os are used to control LEDs, normally they are connected to V_{CC} through a resistor as shown in Figure 26. For a P-port configured as an input, I_{CC} increases as V_I becomes lower than V_{CC} . The LED is a diode, with threshold voltage V_T , and when a P-port is configured as an input the LED is off but V_I is a V_T drop below V_{CC} .

For battery-powered applications, it is essential that the voltage of P-ports controlling LEDs is greater than or equal to V_{CC} when the P-ports are configured as input to minimize current consumption. Figure 27 shows a high-value resistor in parallel with the LED. Figure 28 shows V_{CC} less than the LED supply voltage by at least V_T . Both of these methods maintain the I/O V_I at or above V_{CC} and prevents additional supply current consumption when the P-port is configured as an input and the LED is off.

The TCA9554 has an integrated 100-k Ω pull-up resistor, so there is no need for an external pull-up.

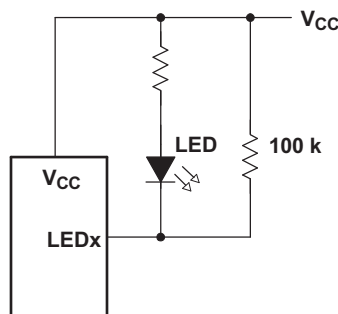

Figure 27. High-Value Resistor in Parallel With LED

Typical Application (continued)

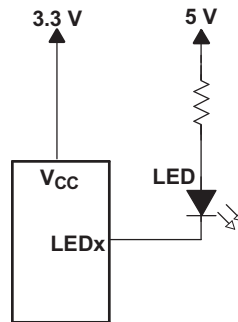

Figure 28. Device Supplied by a Lower Voltage

9.2.2 Detailed Design Procedure

The pull-up resistors, R_p , for the SCL and SDA lines need to be selected appropriately and take into consideration the total capacitance of all slaves on the I²C bus. The minimum pull-up resistance is a function of V_{CC} , $V_{OL(max)}$, and I_{OL} as shown in Equation 5.

$$R_{p(min)} = \frac{V_{CC} - V_{OL(max)}}{I_{OL}} \tag{5}$$

The maximum pull-up resistance is a function of the maximum rise time, t_r (300 ns for fast-mode operation, $f_{SCL} = 400$ kHz) and bus capacitance, C_b as shown in Equation 6.

$$R_{p(max)} = \frac{t_r}{0.8473 \times C_b} \tag{6}$$

The maximum bus capacitance for an I²C bus must not exceed 400 pF for standard-mode or fast-mode operation. The bus capacitance can be approximated by adding the capacitance of the TCA9554, C_i for SCL or C_{i0} for SDA, the capacitance of wires, connections, traces, and the capacitance of additional slaves on the bus.

9.2.3 Application Curves

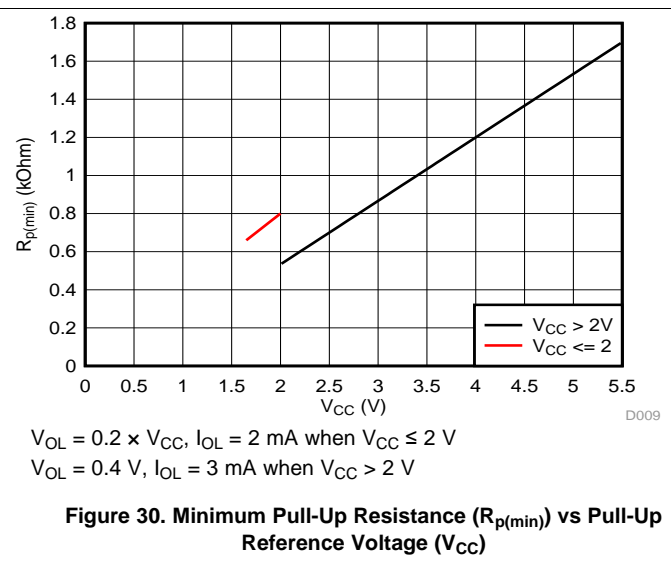
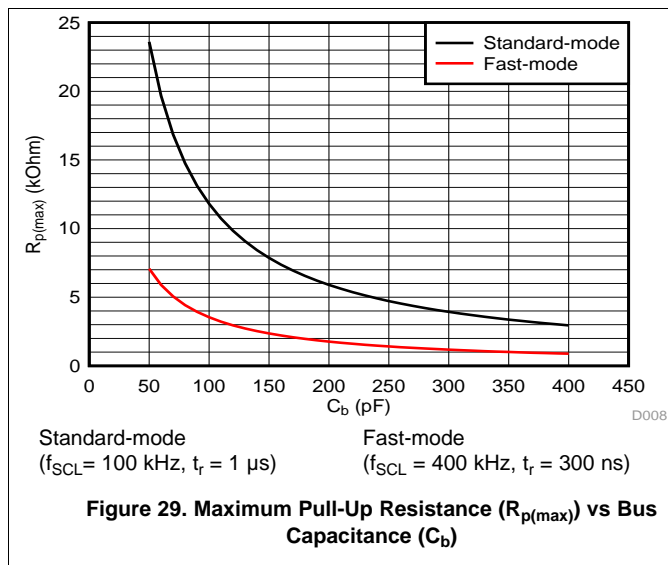

10 Power Supply Recommendations

10.1 Power-On Reset Requirements

In the event of a glitch or data corruption, the TCA9554 can be reset to its default conditions by using the power-on reset feature. Power-on reset requires that the device go through a power cycle to be completely reset. This reset also happens when the device is powered on for the first time in an application.

The power-on reset is shown in Figure 31.

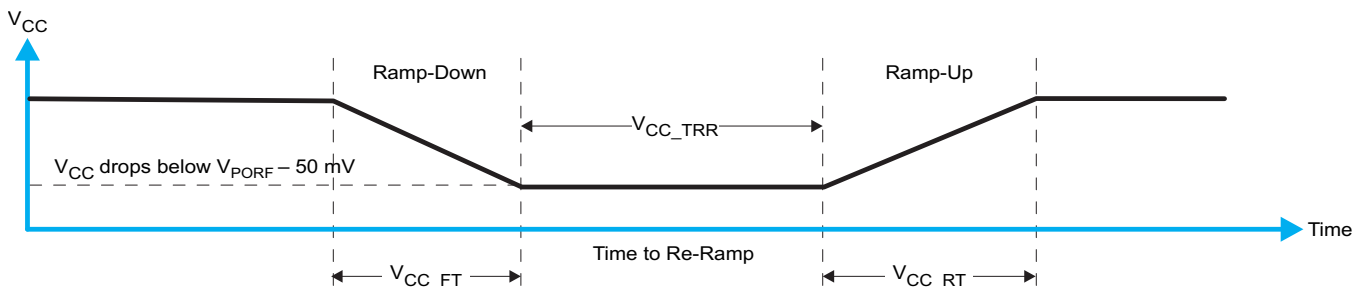

Figure 31. V_{CC} is Lowered Below the POR Threshold, Then Ramped Back Up to V_{CC}

Table 8 specifies the performance of the power-on reset feature for the TCA9554.

Table 8. Recommended Supply Sequencing and Ramp Rates⁽¹⁾

PARAMETER		MIN	MAX	UNIT
V_{CC_FT}	Fall rate	1	2000	ms
V_{CC_RT}	Rise rate	0.1	2000	ms
V_{CC_TRR}	Time to re-ramp (when V_{CC} drops to $V_{POR_MIN} - 50$ mV or when V_{CC} drops to GND)	2		μ s
V_{CC_GH}	Level that V_{CCP} can glitch down to, but not cause a functional disruption when $V_{CC_GW} = 1$ μ s		1.2	V
V_{CC_MV}	The minimum voltage that V_{CC} can glitch down to without causing a reset (V_{CC_GH} must not be violated)	1.5		V
V_{CC_GW}	Glitch width that does not cause a functional disruption when $V_{CC_GH} = 0.5 \times V_{CC}$		10	μ s

(1) All supply sequencing and ramp rate values are measured at $T_A = 25^\circ\text{C}$

Glitches in the power supply can also affect the power-on reset performance of this device. The glitch width (V_{CC_GW}) and height (V_{CC_GH}) are dependent on each other. The bypass capacitance, source impedance, and device impedance are factors that affect power-on reset performance. Figure 32 and Table 8 provide more information on how to measure these specifications.

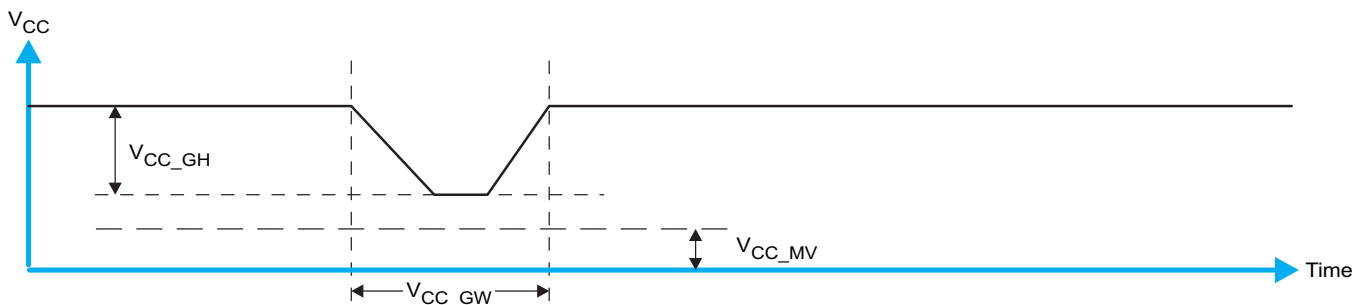

Figure 32. Glitch Width and Glitch Height

V_{PORR} is critical to the power-on reset. V_{PORR} is the voltage level at which the reset condition is released and all the registers and the I²C/SMBus state machine are initialized to their default states. The value of power-on-reset voltage differs based on the V_{CC} being lowered to or from 0 (V_{PORR} or V_{PORF}). [Figure 33](#) and [Table 8](#) provide more details on this specification.

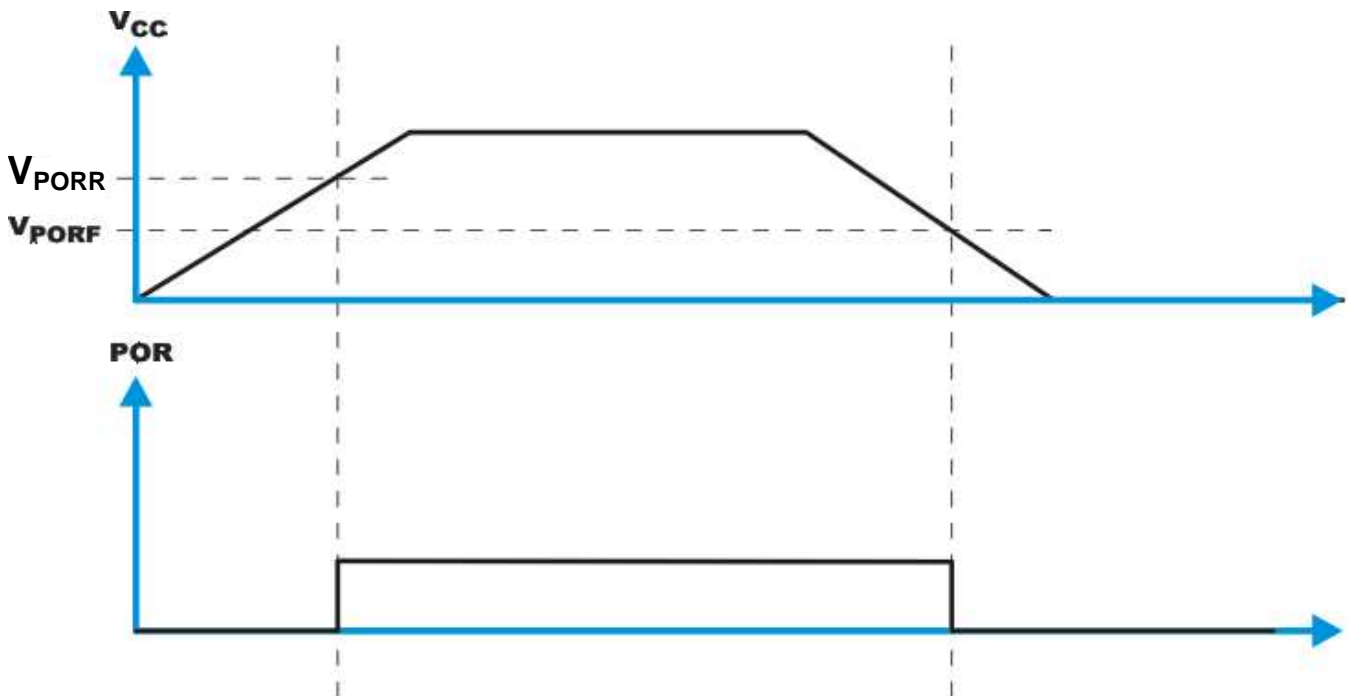

Figure 33. Waveform Describing V_{CC} Voltage Level at Which Power-On-Reset (POR) Occurs

11 Layout

11.1 Layout Guidelines

For printed circuit board (PCB) layout of the TCA9554, common PCB layout practices must be followed but additional concerns related to high-speed data transfer such as matched impedances and differential pairs are not a concern for I²C signal speeds.

In all PCB layouts, it is a best practice to avoid right angles in signal traces, to fan out signal traces away from each other upon leaving the vicinity of an integrated circuit (IC), and to use thicker trace widths to carry higher amounts of current that commonly pass through power and ground traces. By-pass and de-coupling capacitors are commonly used to control the voltage on the VCC pin, using a larger capacitor to provide additional power in the event of a short power supply glitch and a smaller capacitor to filter out high-frequency ripple. These capacitors must be placed as close to the TCA9554 as possible. These best practices are shown in Figure 34.

For the layout example provided in Figure 34, it is possible to fabricate a PCB with only 2 layers by using the top layer for signal routing and the bottom layer as a split plane for power (V_{CC}) and ground (GND). However, a 4 layer board is preferable for boards with higher density signal routing. On a 4 layer PCB, it is common to route signals on the top and bottom layer, dedicate one internal layer to a ground plane, and dedicate the other internal layer to a power plane. In a board layout using planes or split planes for power and ground, vias are placed directly next to the surface mount component pad which needs to attach to V_{CC} or GND and the via is connected electrically to the internal layer or the other side of the board. Vias are also used when a signal trace needs to be routed to the opposite side of the board, but this technique is not demonstrated in Figure 34.

11.2 Layout Example

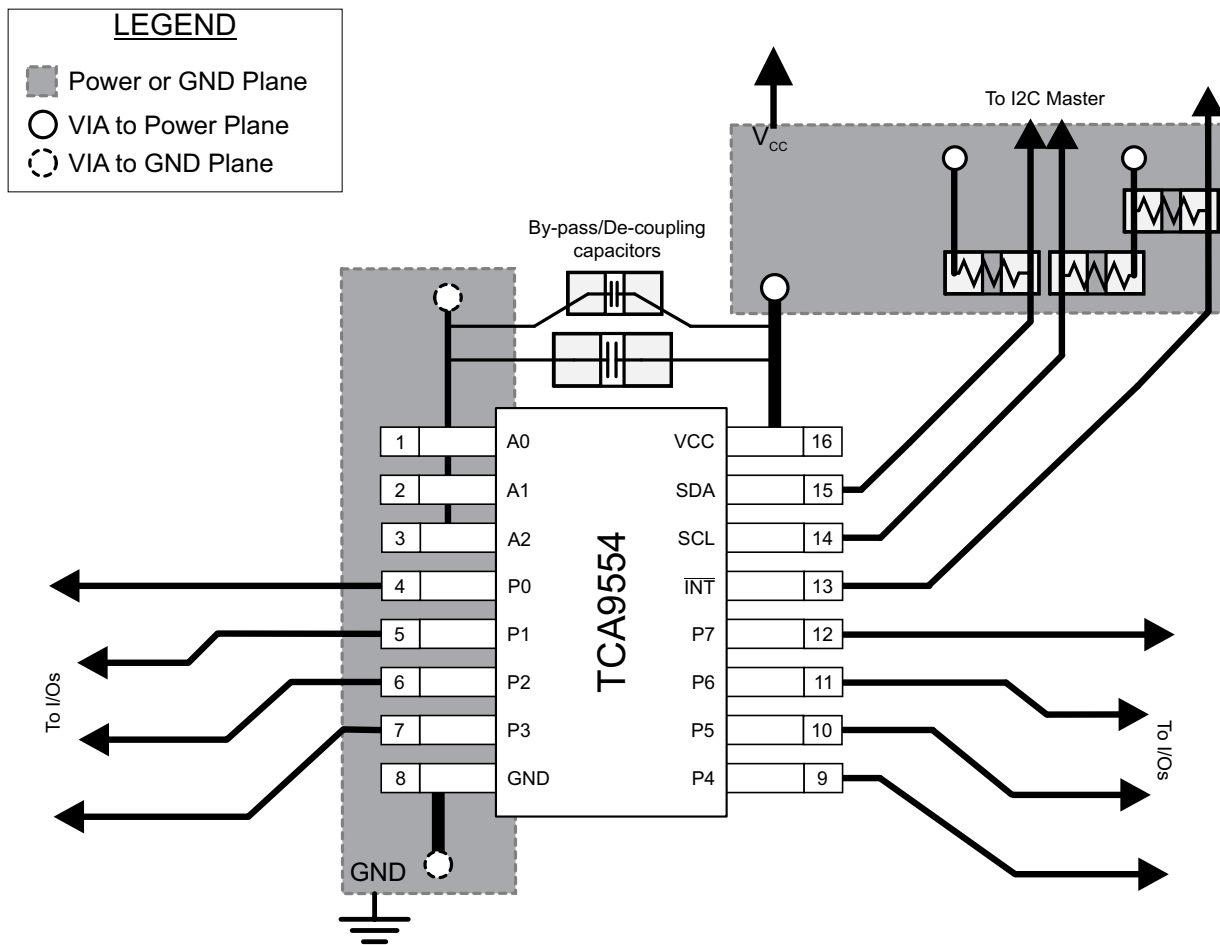

Figure 34. TCA9554 Layout

12 Device and Documentation Support

12.1 Documentation Support

12.1.1 Related Documentation

For related documentation see the following:

- [I2C Pull-up Resistor Calculation](#)
- [Maximum Clock Frequency of I2C Bus Using Repeaters](#)
- [Introduction to Logic](#)
- [Understanding the I2C Bus](#)
- [Choosing the Correct I2C Device for New Designs](#)
- [I/O Expander EVM User's Guide](#)

12.2 Receiving Notification of Documentation Updates

To receive notification of documentation updates, navigate to the device product folder on [ti.com](#). In the upper right corner, click on *Alert me* to register and receive a weekly digest of any product information that has changed. For change details, review the revision history included in any revised document.

12.3 Community Resources

The following links connect to TI community resources. Linked contents are provided "AS IS" by the respective contributors. They do not constitute TI specifications and do not necessarily reflect TI's views; see TI's [Terms of Use](#).

TI E2E™ Online Community *TI's Engineer-to-Engineer (E2E) Community*. Created to foster collaboration among engineers. At [e2e.ti.com](#), you can ask questions, share knowledge, explore ideas and help solve problems with fellow engineers.

Design Support *TI's Design Support* Quickly find helpful E2E forums along with design support tools and contact information for technical support.

12.4 Trademarks

E2E is a trademark of Texas Instruments.
All other trademarks are the property of their respective owners.

12.5 Electrostatic Discharge Caution



These devices have limited built-in ESD protection. The leads should be shorted together or the device placed in conductive foam during storage or handling to prevent electrostatic damage to the MOS gates.

12.6 Glossary

[SLYZ022](#) — *TI Glossary*.

This glossary lists and explains terms, acronyms, and definitions.

13 Mechanical, Packaging, and Orderable Information

The following pages include mechanical, packaging, and orderable information. This information is the most current data available for the designated devices. This data is subject to change without notice and revision of this document. For browser-based versions of this data sheet, refer to the left-hand navigation.

PACKAGING INFORMATION

Orderable Device	Status (1)	Package Type	Package Drawing	Pins	Package Qty	Eco Plan (2)	Lead/Ball Finish (6)	MSL Peak Temp (3)	Op Temp (°C)	Device Marking (4/5)	Samples
TCA9554DBQR	ACTIVE	SSOP	DBQ	16	2500	Green (RoHS & no Sb/Br)	CU NIPDAU	Level-2-260C-1 YEAR	-40 to 85	9554	Samples
TCA9554DBR	ACTIVE	SSOP	DB	16	2000	Green (RoHS & no Sb/Br)	CU NIPDAU	Level-1-260C-UNLIM	-40 to 85	TD554	Samples
TCA9554DWR	ACTIVE	SOIC	DW	16	2000	Green (RoHS & no Sb/Br)	CU NIPDAU	Level-1-260C-UNLIM	-40 to 85	TCA9554	Samples
TCA9554DWT	ACTIVE	SOIC	DW	16	250	Green (RoHS & no Sb/Br)	CU NIPDAU	Level-1-260C-UNLIM	-40 to 85	TCA9554	Samples
TCA9554PWR	ACTIVE	TSSOP	PW	16	2000	Green (RoHS & no Sb/Br)	CU NIPDAU	Level-1-260C-UNLIM	-40 to 85	PW554	Samples

(1) The marketing status values are defined as follows:

ACTIVE: Product device recommended for new designs.

LIFEBUY: TI has announced that the device will be discontinued, and a lifetime-buy period is in effect.

NRND: Not recommended for new designs. Device is in production to support existing customers, but TI does not recommend using this part in a new design.

PREVIEW: Device has been announced but is not in production. Samples may or may not be available.

OBSOLETE: TI has discontinued the production of the device.

(2) Eco Plan - The planned eco-friendly classification: Pb-Free (RoHS), Pb-Free (RoHS Exempt), or Green (RoHS & no Sb/Br) - please check <http://www.ti.com/productcontent> for the latest availability information and additional product content details.

TBD: The Pb-Free/Green conversion plan has not been defined.

Pb-Free (RoHS): TI's terms "Lead-Free" or "Pb-Free" mean semiconductor products that are compatible with the current RoHS requirements for all 6 substances, including the requirement that lead not exceed 0.1% by weight in homogeneous materials. Where designed to be soldered at high temperatures, TI Pb-Free products are suitable for use in specified lead-free processes.

Pb-Free (RoHS Exempt): This component has a RoHS exemption for either 1) lead-based flip-chip solder bumps used between the die and package, or 2) lead-based die adhesive used between the die and leadframe. The component is otherwise considered Pb-Free (RoHS compatible) as defined above.

Green (RoHS & no Sb/Br): TI defines "Green" to mean Pb-Free (RoHS compatible), and free of Bromine (Br) and Antimony (Sb) based flame retardants (Br or Sb do not exceed 0.1% by weight in homogeneous material)

(3) MSL, Peak Temp. - The Moisture Sensitivity Level rating according to the JEDEC industry standard classifications, and peak solder temperature.

(4) There may be additional marking, which relates to the logo, the lot trace code information, or the environmental category on the device.

(5) Multiple Device Markings will be inside parentheses. Only one Device Marking contained in parentheses and separated by a "~" will appear on a device. If a line is indented then it is a continuation of the previous line and the two combined represent the entire Device Marking for that device.

⁽⁶⁾ Lead/Ball Finish - Orderable Devices may have multiple material finish options. Finish options are separated by a vertical ruled line. Lead/Ball Finish values may wrap to two lines if the finish value exceeds the maximum column width.

Important Information and Disclaimer:The information provided on this page represents TI's knowledge and belief as of the date that it is provided. TI bases its knowledge and belief on information provided by third parties, and makes no representation or warranty as to the accuracy of such information. Efforts are underway to better integrate information from third parties. TI has taken and continues to take reasonable steps to provide representative and accurate information but may not have conducted destructive testing or chemical analysis on incoming materials and chemicals. TI and TI suppliers consider certain information to be proprietary, and thus CAS numbers and other limited information may not be available for release.

In no event shall TI's liability arising out of such information exceed the total purchase price of the TI part(s) at issue in this document sold by TI to Customer on an annual basis.

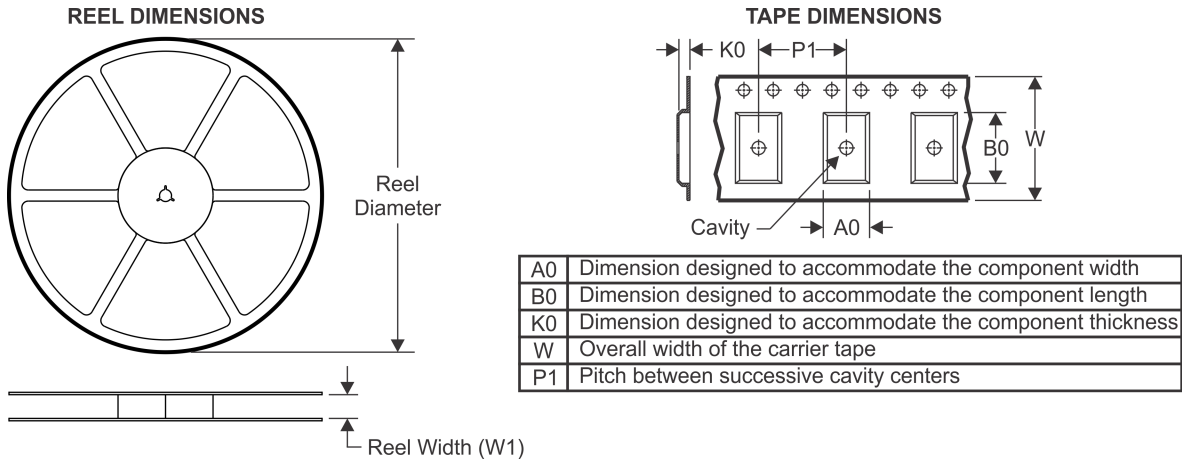
TAPE AND REEL INFORMATION

QUADRANT ASSIGNMENTS FOR PIN 1 ORIENTATION IN TAPE

*All dimensions are nominal

Device	Package Type	Package Drawing	Pins	SPQ	Reel Diameter (mm)	Reel Width W1 (mm)	A0 (mm)	B0 (mm)	K0 (mm)	P1 (mm)	W (mm)	Pin1 Quadrant
TCA9554DBQR	SSOP	DBQ	16	2500	330.0	12.5	6.4	5.2	2.1	8.0	12.0	Q1
TCA9554DWR	SOIC	DW	16	2000	330.0	16.4	10.75	10.7	2.7	12.0	16.0	Q1
TCA9554DWT	SOIC	DW	16	250	180.0	16.4	10.75	10.7	2.7	12.0	16.0	Q1
TCA9554PWR	TSSOP	PW	16	2000	330.0	12.4	6.9	5.6	1.6	8.0	12.0	Q1

TAPE AND REEL BOX DIMENSIONS



*All dimensions are nominal

Device	Package Type	Package Drawing	Pins	SPQ	Length (mm)	Width (mm)	Height (mm)
TCA9554DBQR	SSOP	DBQ	16	2500	340.5	338.1	20.6
TCA9554DWR	SOIC	DW	16	2000	350.0	350.0	43.0
TCA9554DWT	SOIC	DW	16	250	213.0	191.0	55.0
TCA9554PWR	TSSOP	PW	16	2000	367.0	367.0	35.0

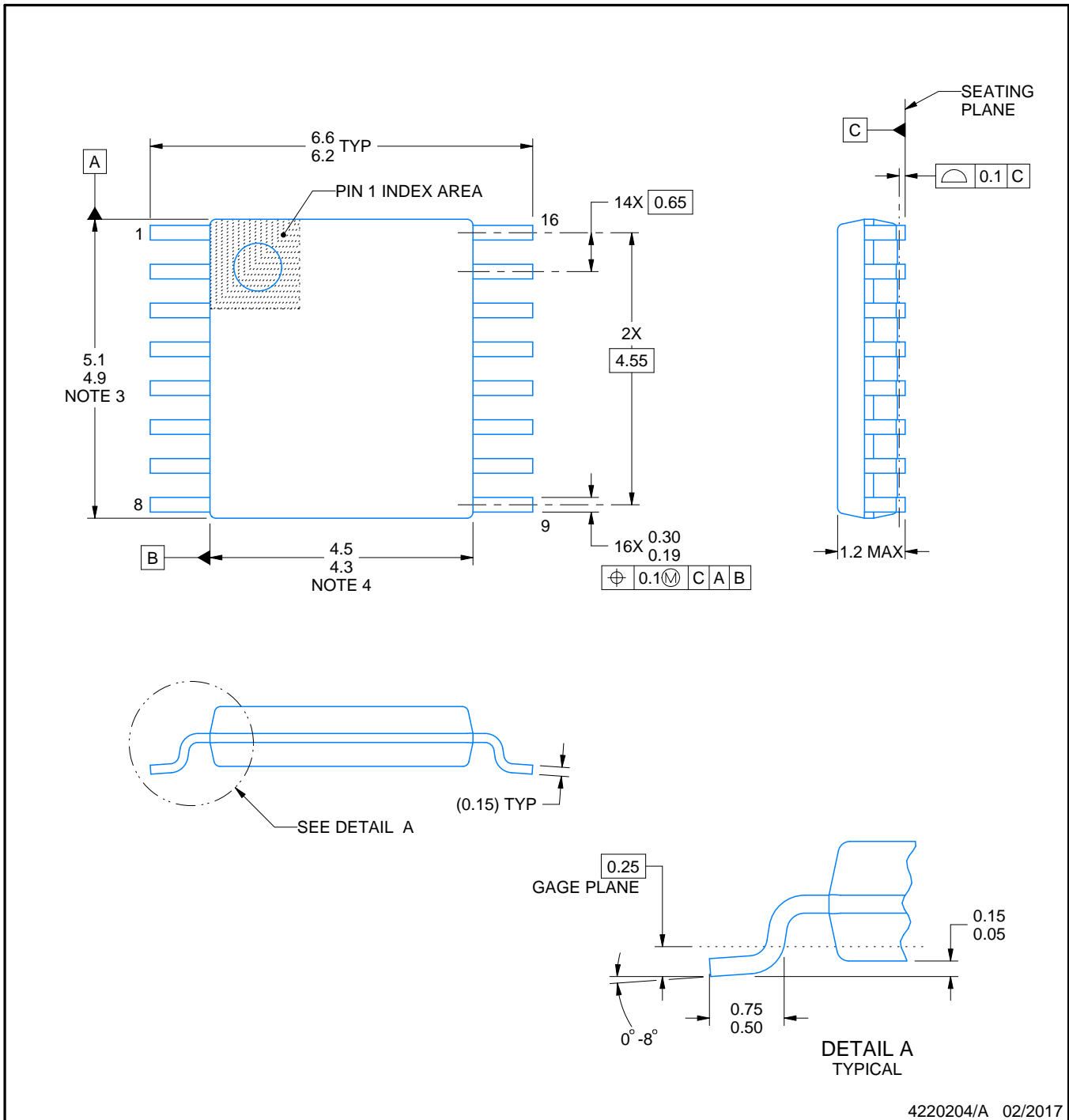

4220204/A 02/2017

NOTES:

1. All linear dimensions are in millimeters. Any dimensions in parenthesis are for reference only. Dimensioning and tolerancing per ASME Y14.5M.
2. This drawing is subject to change without notice.
3. This dimension does not include mold flash, protrusions, or gate burrs. Mold flash, protrusions, or gate burrs shall not exceed 0.15 mm per side.
4. This dimension does not include interlead flash. Interlead flash shall not exceed 0.25 mm per side.
5. Reference JEDEC registration MO-153.

EXAMPLE BOARD LAYOUT

PW0016A

TSSOP - 1.2 mm max height

SMALL OUTLINE PACKAGE



LAND PATTERN EXAMPLE
EXPOSED METAL SHOWN
SCALE: 10X



4220204/A 02/2017

NOTES: (continued)

- 6. Publication IPC-7351 may have alternate designs.
- 7. Solder mask tolerances between and around signal pads can vary based on board fabrication site.

EXAMPLE STENCIL DESIGN

PW0016A

TSSOP - 1.2 mm max height

SMALL OUTLINE PACKAGE

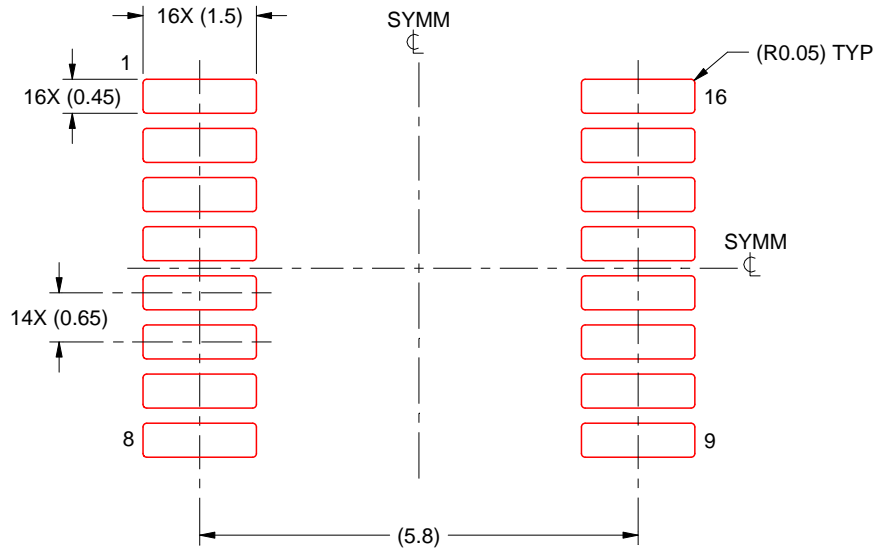

SOLDER PASTE EXAMPLE
BASED ON 0.125 mm THICK STENCIL
SCALE: 10X

4220204/A 02/2017

NOTES: (continued)

8. Laser cutting apertures with trapezoidal walls and rounded corners may offer better paste release. IPC-7525 may have alternate design recommendations.
9. Board assembly site may have different recommendations for stencil design.

DB (R-PDSO-G**)

PLASTIC SMALL-OUTLINE

28 PINS SHOWN



- NOTES: A. All linear dimensions are in millimeters.
 B. This drawing is subject to change without notice.
 C. Body dimensions do not include mold flash or protrusion not to exceed 0,15.
 D. Falls within JEDEC MO-150

GENERIC PACKAGE VIEW

DBQ 16

SSOP - 1.75 mm max height

SHRINK SMALL-OUTLINE PACKAGE

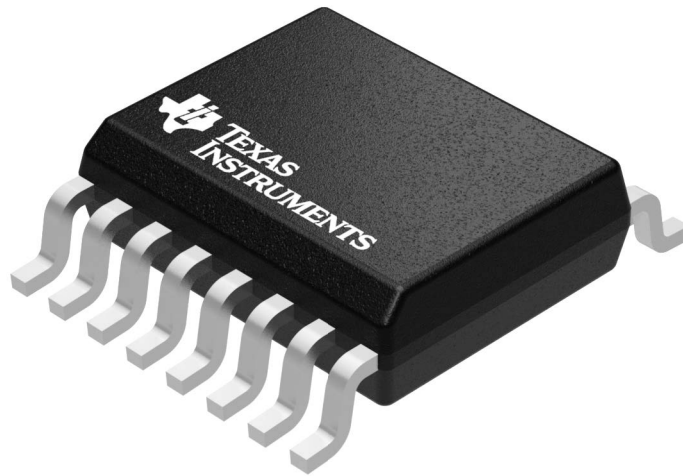

Images above are just a representation of the package family, actual package may vary.
Refer to the product data sheet for package details.

4073301-2/1

EXAMPLE BOARD LAYOUT

DBQ0016A

SSOP - 1.75 mm max height

SHRINK SMALL-OUTLINE PACKAGE

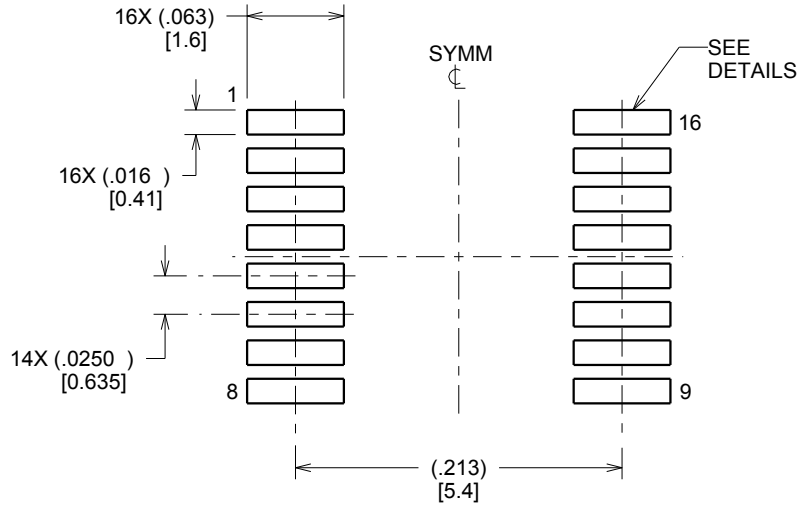

LAND PATTERN EXAMPLE
SCALE:8X

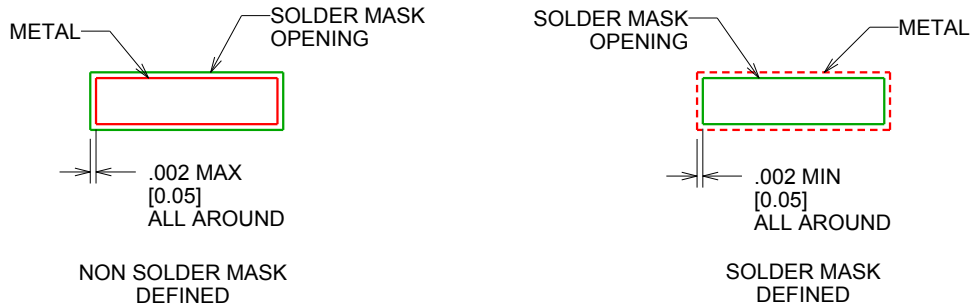

SOLDER MASK DETAILS

4214846/A 03/2014

NOTES: (continued)

- 6. Publication IPC-7351 may have alternate designs.
- 7. Solder mask tolerances between and around signal pads can vary based on board fabrication site.

EXAMPLE STENCIL DESIGN

DBQ0016A

SSOP - 1.75 mm max height

SHRINK SMALL-OUTLINE PACKAGE

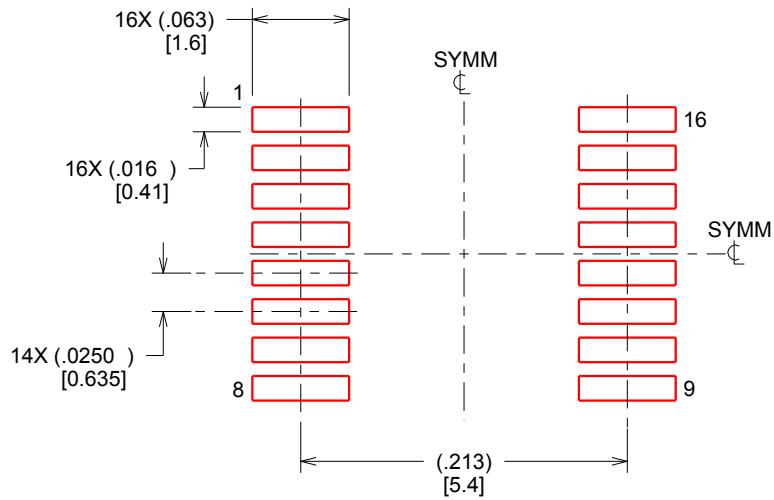

SOLDER PASTE EXAMPLE
BASED ON .005 INCH [0.127 MM] THICK STENCIL
SCALE:8X

4214846/A 03/2014

NOTES: (continued)

8. Laser cutting apertures with trapezoidal walls and rounded corners may offer better paste release. IPC-7525 may have alternate design recommendations.
9. Board assembly site may have different recommendations for stencil design.

GENERIC PACKAGE VIEW

DW 16

SOIC - 2.65 mm max height

7.5 x 10.3, 1.27 mm pitch

SMALL OUTLINE INTEGRATED CIRCUIT

This image is a representation of the package family, actual package may vary.
Refer to the product data sheet for package details.

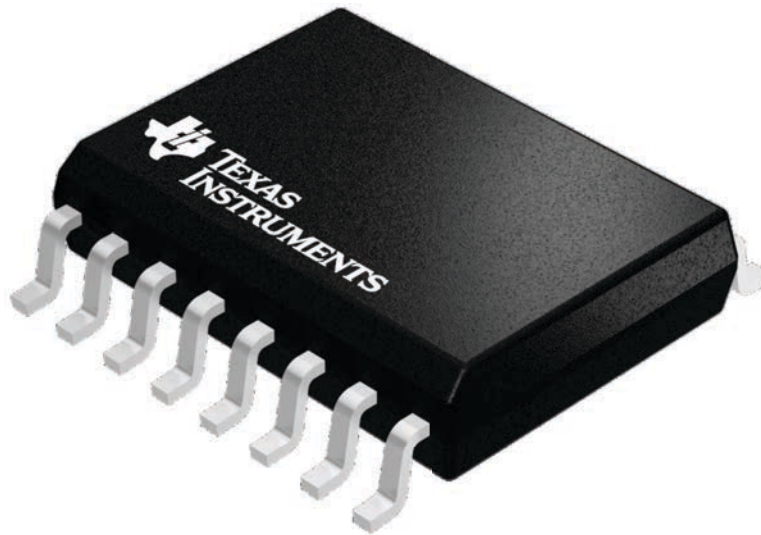

4224780/A

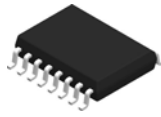

DW0016A

PACKAGE OUTLINE SOIC - 2.65 mm max height

SOIC

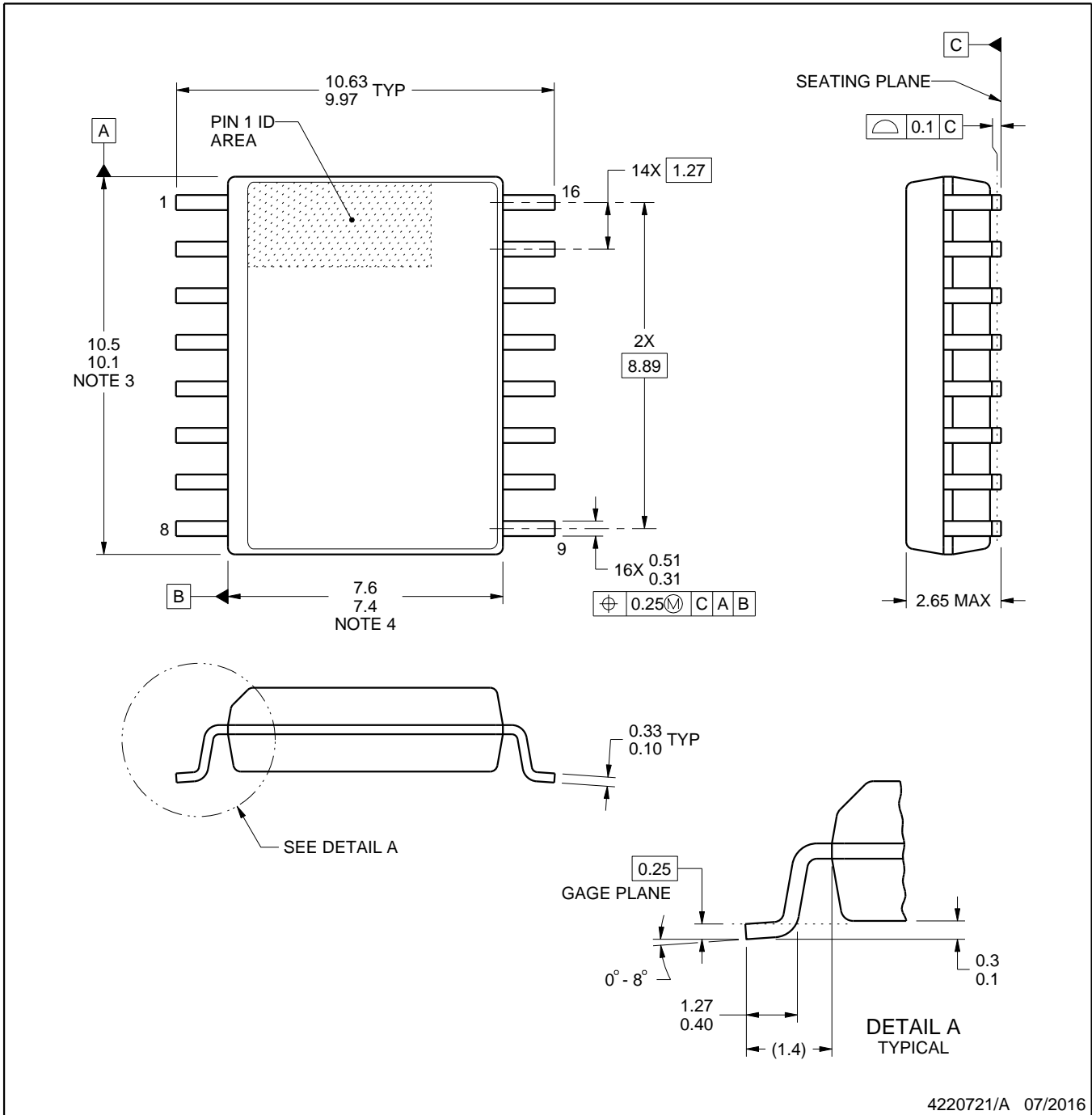

4220721/A 07/2016

NOTES:

1. All linear dimensions are in millimeters. Dimensions in parenthesis are for reference only. Dimensioning and tolerancing per ASME Y14.5M.
2. This drawing is subject to change without notice.
3. This dimension does not include mold flash, protrusions, or gate burrs. Mold flash, protrusions, or gate burrs shall not exceed 0.15 mm, per side.
4. This dimension does not include interlead flash. Interlead flash shall not exceed 0.25 mm, per side.
5. Reference JEDEC registration MS-013.

EXAMPLE BOARD LAYOUT

DW0016A

SOIC - 2.65 mm max height

SOIC

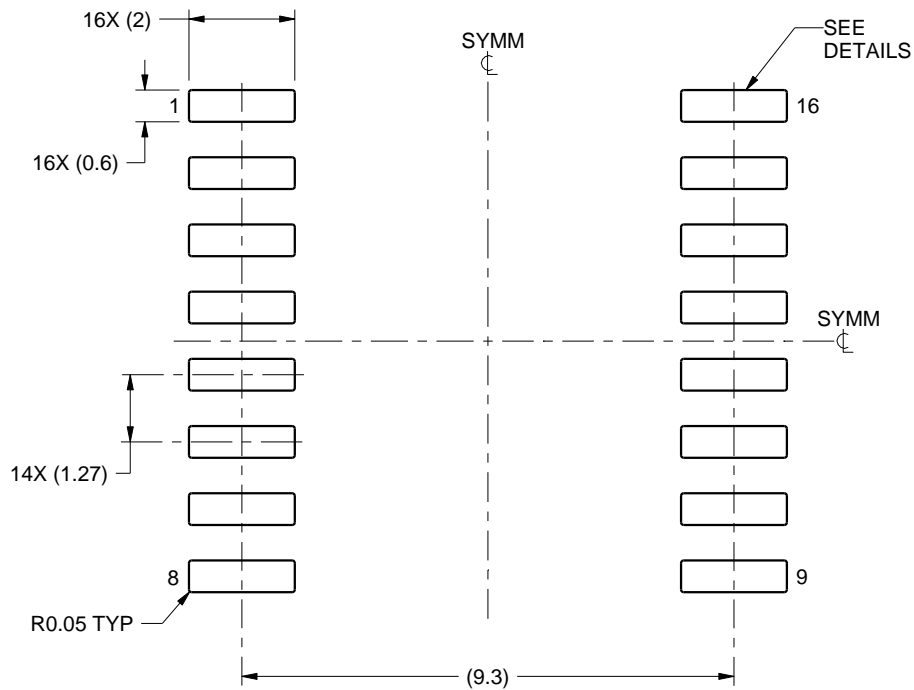

LAND PATTERN EXAMPLE
SCALE:7X

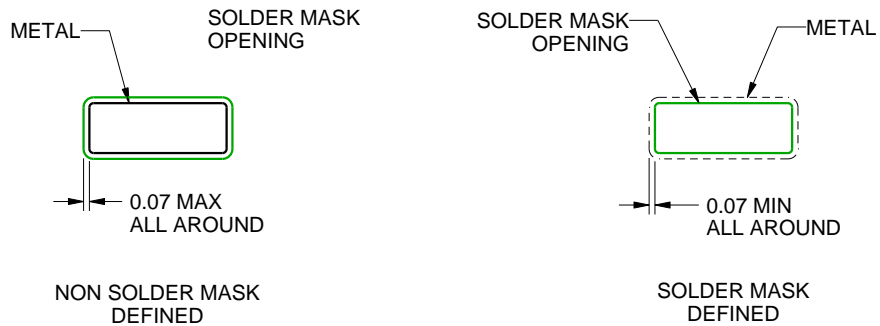

SOLDER MASK DETAILS

4220721/A 07/2016

NOTES: (continued)

- 6. Publication IPC-7351 may have alternate designs.
- 7. Solder mask tolerances between and around signal pads can vary based on board fabrication site.

EXAMPLE STENCIL DESIGN

DW0016A

SOIC - 2.65 mm max height

SOIC

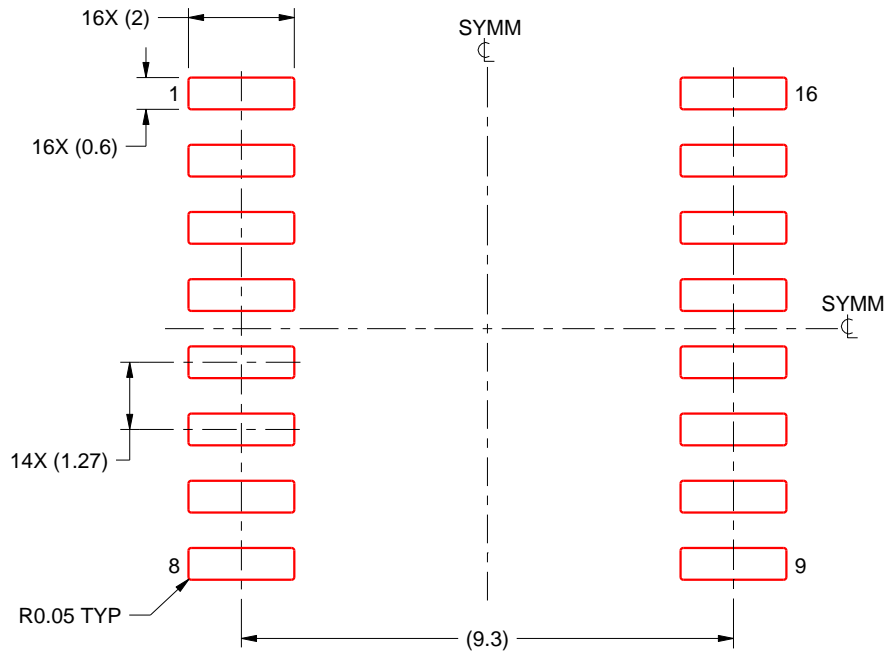

SOLDER PASTE EXAMPLE
BASED ON 0.125 mm THICK STENCIL
SCALE:7X

4220721/A 07/2016

NOTES: (continued)

8. Laser cutting apertures with trapezoidal walls and rounded corners may offer better paste release. IPC-7525 may have alternate design recommendations.
9. Board assembly site may have different recommendations for stencil design.

IMPORTANT NOTICE AND DISCLAIMER

TI PROVIDES TECHNICAL AND RELIABILITY DATA (INCLUDING DATASHEETS), DESIGN RESOURCES (INCLUDING REFERENCE DESIGNS), APPLICATION OR OTHER DESIGN ADVICE, WEB TOOLS, SAFETY INFORMATION, AND OTHER RESOURCES "AS IS" AND WITH ALL FAULTS, AND DISCLAIMS ALL WARRANTIES, EXPRESS AND IMPLIED, INCLUDING WITHOUT LIMITATION ANY IMPLIED WARRANTIES OF MERCHANTABILITY, FITNESS FOR A PARTICULAR PURPOSE OR NON-INFRINGEMENT OF THIRD PARTY INTELLECTUAL PROPERTY RIGHTS.

These resources are intended for skilled developers designing with TI products. You are solely responsible for (1) selecting the appropriate TI products for your application, (2) designing, validating and testing your application, and (3) ensuring your application meets applicable standards, and any other safety, security, or other requirements. These resources are subject to change without notice. TI grants you permission to use these resources only for development of an application that uses the TI products described in the resource. Other reproduction and display of these resources is prohibited. No license is granted to any other TI intellectual property right or to any third party intellectual property right. TI disclaims responsibility for, and you will fully indemnify TI and its representatives against, any claims, damages, costs, losses, and liabilities arising out of your use of these resources.

TI's products are provided subject to TI's Terms of Sale (www.ti.com/legal/termsofsale.html) or other applicable terms available either on ti.com or provided in conjunction with such TI products. TI's provision of these resources does not expand or otherwise alter TI's applicable warranties or warranty disclaimers for TI products.

Mailing Address: Texas Instruments, Post Office Box 655303, Dallas, Texas 75265
Copyright © 2019, Texas Instruments Incorporated

Looking for pricing, stock, or lifecycle information?

Click below to explore more details on WIN SOURCE:

 [View TCA9554PWR](#) on WIN SOURCE

 [Texas Instruments](#) Information

Optimize Your Supply Chain with WIN SOURCE Solutions

-  Global Sourcing Solution
-  Obsolete Management
-  Cost Control Management
-  Shortage Management
-  Alternative Solution
-  Excess Inventory Management