



# LM2791 Current Regulated Switched Capacitor LED Driver with Analog Brightness Control

Check for Samples: [LM2791](#)

## FEATURES

- Output Matching of  $\pm 0.3\%$
- Drives up to Two LEDs
- 3V to 5.8V Input Voltage
- Up to 36mA Output Current
- Soft Start Limits Inrush Current
- Analog Brightness Control
- Separate Shutdown Input
- Very Small Solution Size - No Inductor
- 0.7mA Typical Operating Current
- 1 $\mu$ A (max.) Shutdown Current
- 450kHz Switching Frequency (min.)
- Linear Regulation Generates Predictable Noise Spectrum
- WSON-10 Package: 3mm X 3mm X 0.8mm

## APPLICATIONS

- White LED Display Backlights
- White LED Keypad Backlights
- 1-Cell Li-Ion Battery-Operated Equipment Including PDAs, Hand-Held PCs, Cellular Phones
- Flat Panel Displays

## Basic Application Circuit

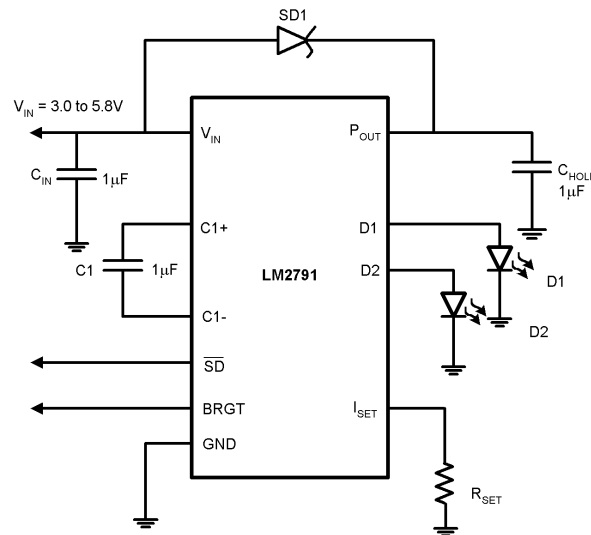

## DESCRIPTION

The LM2791 is a CMOS charge-pump voltage doubler and regulator that provides two regulated current sources. The LM2791 is designed to drive two white (or blue) LEDs with matched currents (within  $\pm 0.3\%$ ) to produce balanced light sources for display backlights. They accept an input voltage range from 3V to 5.8V and maintain a constant current determined by an external set resistor.

The LM2791 delivers up to 36mA of load current to accommodate two high forward voltage (typically white) LEDs. The switching frequency is 450kHz (min.) to keep the conducted noise spectrum away from sensitive frequencies within portable RF devices.

In the LM2791, brightness is controlled by applying a voltage between GND and 3.0V to the BRGT pin. The LM2791 is available in active high or low shutdown versions. The shutdown pin reduces the operating current to 1 $\mu$ A (max.).

The LM2791 is available in a 10 pin WSON CSP package.



Please be aware that an important notice concerning availability, standard warranty, and use in critical applications of Texas Instruments semiconductor products and disclaimers thereto appears at the end of this data sheet.

All trademarks are the property of their respective owners.

## Connection Diagram

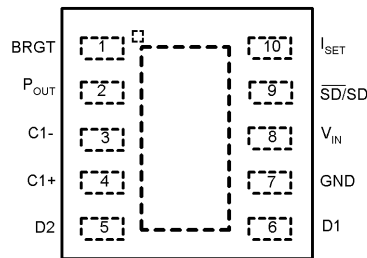
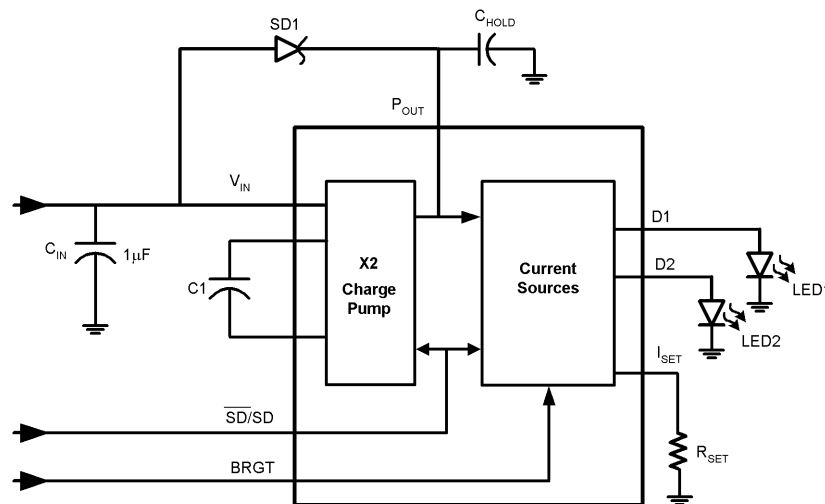

**Figure 1. Top View  
10-Lead WSON**

### PIN DESCRIPTIONS

Pin	Name	Function
1	BRGT	Variable voltage input controls output current.
2	P <sub>OUT</sub>	Charge pump output.
3	C1-	Connect this pin to the negative terminal of C1.
4	C1+	Connect this pin to the positive terminal of C1.
5	D2	Current source outputs. Connect directly to LED.
6	D1	Current source outputs. Connect directly to LED.
7	GND	Power supply ground input.
8	V <sub>IN</sub>	Power supply voltage input.
9	SD/ $\overline{\text{SD}}$	Shutdown input. Device operation is inhibited when pin is asserted.
10	I <sub>SET</sub>	Current Sense Input. Connect resistor to ground to set constant current through LED.

## Block Diagram



These devices have limited built-in ESD protection. The leads should be shorted together or the device placed in conductive foam during storage or handling to prevent electrostatic damage to the MOS gates.

**Absolute Maximum Ratings<sup>(1)</sup>**

$V_{IN}$	-0.3 to 6V
BRGT, SD	-0.3 to ( $V_{IN} + 0.2V$ )
Power Dissipation <sup>(2)</sup>	400 mW
$T_{JMAX}$ <sup>(2)</sup>	150°C
$\theta_{JA}$ <sup>(3)</sup>	55°C/W
Storage Temperature	-65°C to +100°C
Lead Temp. (Soldering, 5 sec.)	260°C
ESD Rating	
Human Body Model	2KV
Machine Model	200V

(1) Absolute maximum ratings indicate limits beyond which damage to the device may occur. Electrical specifications do not apply when operating the device beyond its rated operating conditions.

(2) D1 and D2 may be shorted to GND without damage.  $P_{OUT}$  may be shorted to GND for 1sec without damage.

(3) For more information regarding the WSON package, please refer to Application note AN-1187. ([SNOA401](#))

**Operating Conditions**

Input Voltage ( $V_{IN}$ )	3.0V to 5.8V
BRGT	0 to 3.0V
Ambient Temperature ( $T_A$ )	-30°C to +85°C
Junction Temperature ( $T_J$ )	-30°C to +100°C

## Electrical Characteristics<sup>(1)</sup>

Limits in standard typeface are for  $T_J = 25^\circ\text{C}$  and limits in **boldface type** apply over the full **Operating Temperature Range**. Unless otherwise specified,  $C_1 = C_{IN} = C_{HOLD} = 1\ \mu\text{F}$ ,  $V_{IN} = 3.6\text{V}$ ,  $V_{DIODE} = 3.6\text{V}$ ,  $R_{SET} = 332\Omega$ , BRGT pin = 0V.

Symbol	Parameter	Conditions	Min	Typ	Max	Units
$I_{DX}$	Diode Current at ID1,2	$V_{IN} = 3\text{V}$ , $R_{SET} = 270\Omega$	16.5	18		mA
	Available Current at Output Dx	$V_{IN} = 3\text{V}$		14.5		
		$V_{IN} = 3.3\text{V}$	<b>12.8</b>	15.1	<b>17.7</b>	
		$V_{IN} = 3.6\text{V}$	<b>13.3</b>	15.7	<b>18.4</b>	
		$V_{IN} = 4.4\text{V}$		16.8		
$I_{DX}$	Load Regulation at Output Dx	$V_{IN} = 3.6\text{V}$ $V_{DX} = 3.0\text{V}$ $V_{DX} = 4.0\text{V}$		16 15.4		mA
$I_{DX}$	Line Regulation of Dx Output Current	$3.3\text{V} \leq V_{IN} \leq 4.4\text{V}$ $V_{DX} = 3.6\text{V}$		15.7		mA
$I_{D-MATCH}$	Current Matching Between Any Two Outputs	$3.0\text{V} \leq V_{IN} \leq 4.4\text{V}$ $V_{D1}, V_{D2} = 3.6\text{V}$		0.3		%
$I_Q$	Quiescent Supply Current	$3.0\text{V} \leq V_{IN} \leq 4.4\text{V}$ , Active, No Load Current		0.7	<b>2</b>	mA
$I_{SD}$	Shutdown Supply Current	$3.0\text{V} \leq V_{IN} \leq 5.5\text{V}$ , Shutdown at $85^\circ\text{C}$		0.1 0.3	1	$\mu\text{A}$
$V_{IH}$	SD Input Logic High	$3.0\text{V} \leq V_{IN} \leq 5.5\text{V}$ , <sup>(2)</sup>	$0.8V_{IN}$			V
$V_{IL}$	SD Input Logic Low	$3.0\text{V} \leq V_{IN} \leq 5.5\text{V}$ , <sup>(2)</sup>			$0.2V_{IN}$	V
$I_{LEAK-SD}$	SD Input Leakage Current	$0\text{V} \leq V_{SD} \leq V_{IN}$		0.1		$\mu\text{A}$
$R_{BRGT}$	BRGT Input Resistance			250		k $\Omega$
$I_{SET}$	$I_{SET}$ Pin Output Current			$I_{DX}/25$		mA
$f_{SW}$	Switching Frequency <sup>(3)</sup>	$3.0\text{V} \leq V_{IN} \leq 4.4\text{V}$	<b>450</b>	650	<b>850</b>	kHz
$t_{START}$	Startup Time <sup>(4)</sup>	$I_{DX} = 90\%$ steady state		10		$\mu\text{s}$

- (1) In the test circuit, all capacitors are 1.0 $\mu\text{F}$ , 0.3 $\Omega$  maximum ESR capacitors. Capacitors with higher ESR will increase output resistance, reduce output voltage and efficiency.
- (2) The internal thresholds of the shutdown bar are set at about 40% of  $V_{IN}$ .
- (3) The output switches operate at one half of the oscillator frequency,  $f_{OSC} = 2f_{SW}$ .
- (4) Specified by design. Not product in tested.

### Typical Performance Characteristics

Unless otherwise specified,  $C_1 = C_{IN}$ ,  $C_{HOLD} = 1\mu F$ ,  $V_{IN} = 3.6V$ ,  $V_{DIODE} = 3.6V$ ,  $BRGT\ pin = 0V$ ,  $R_{SET} = 330\Omega$

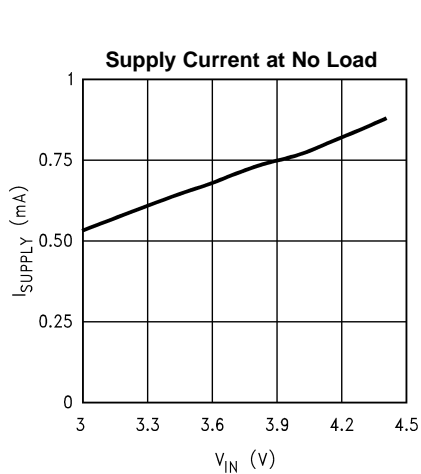

Figure 2.

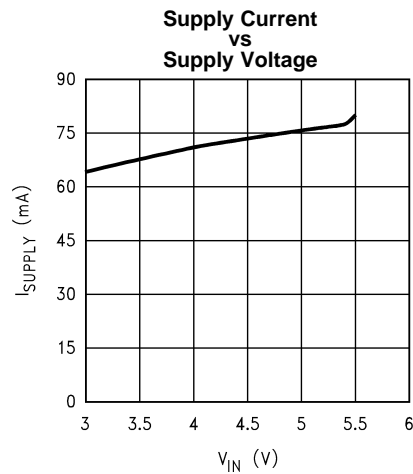

Figure 3.

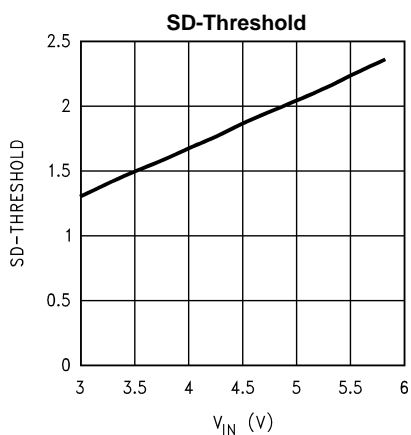

Figure 4.

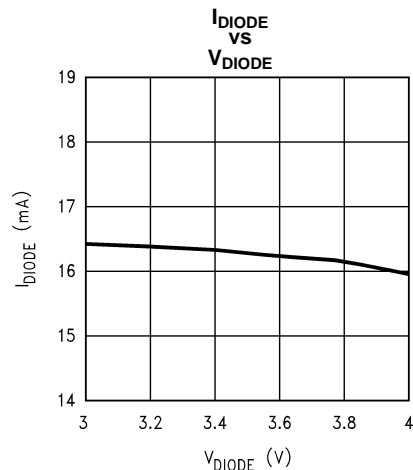

Figure 5.

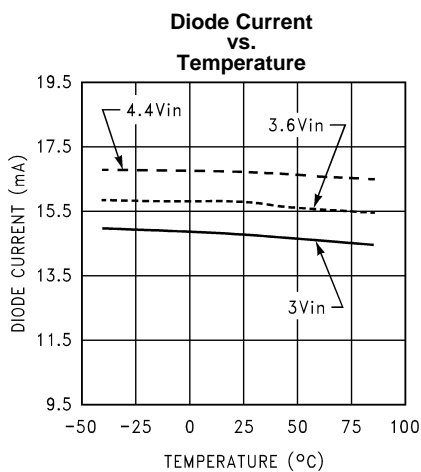

Figure 6.

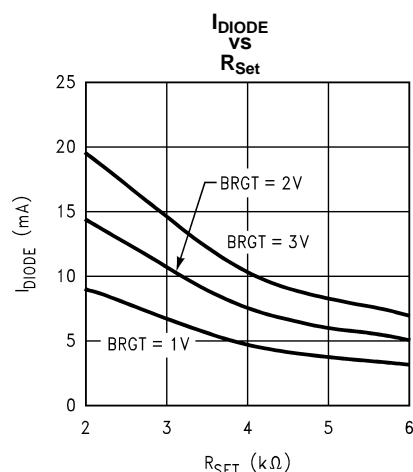

Figure 7.

**Typical Performance Characteristics (continued)**

Unless otherwise specified,  $C_1 = C_{IN}$ ,  $C_{HOLD} = 1\mu F$ ,  $V_{IN} = 3.6V$ ,  $V_{DIODE} = 3.6V$ , BRGT pin = 0V,  $R_{SET} = 330\Omega$

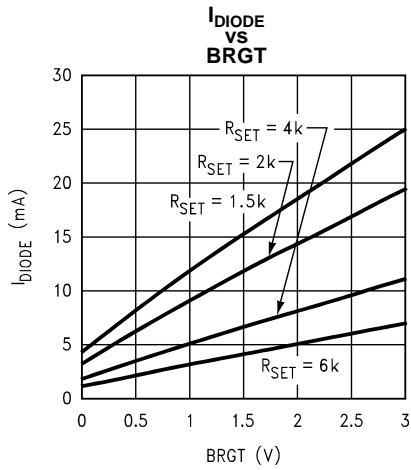

Figure 8.

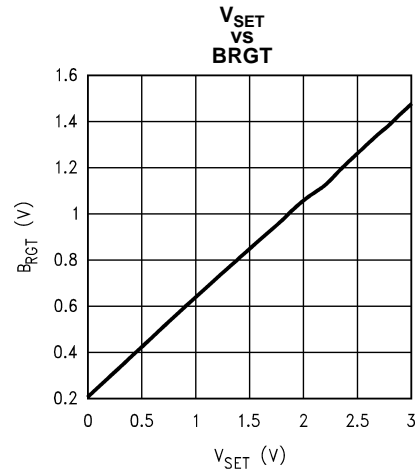

Figure 9.

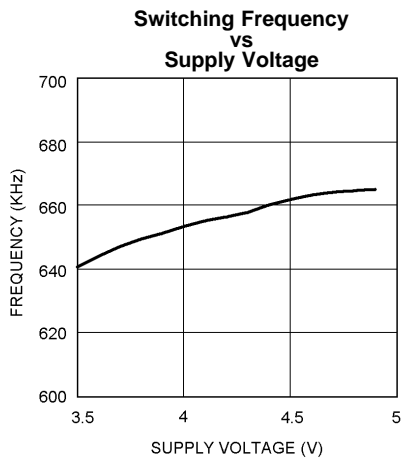

Figure 10.

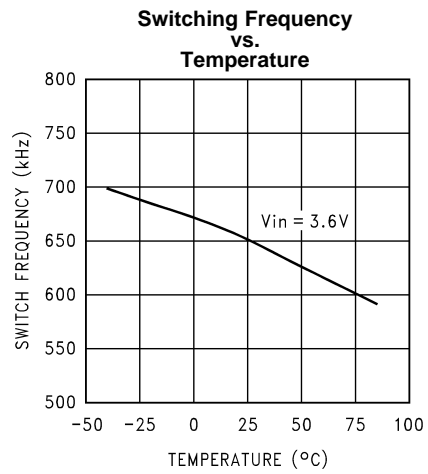

Figure 11.

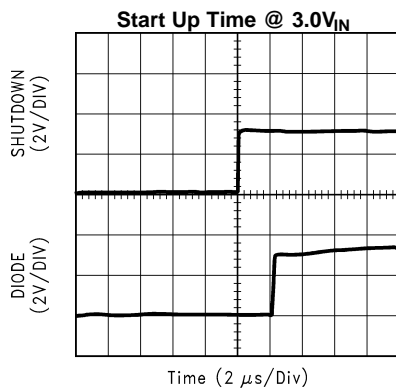

Figure 12.

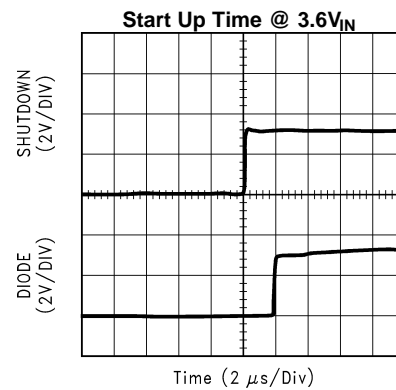
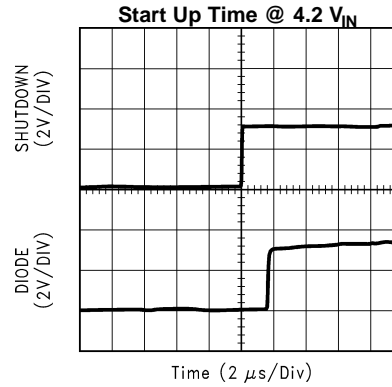

Figure 13.

**Typical Performance Characteristics (continued)**

Unless otherwise specified,  $C_1 = C_{IN}$ ,  $C_{HOLD} = 1\mu F$ ,  $V_{IN} = 3.6V$ ,  $V_{DIODE} = 3.6V$ , BRGT pin = 0V,  $R_{SET} = 330\Omega$

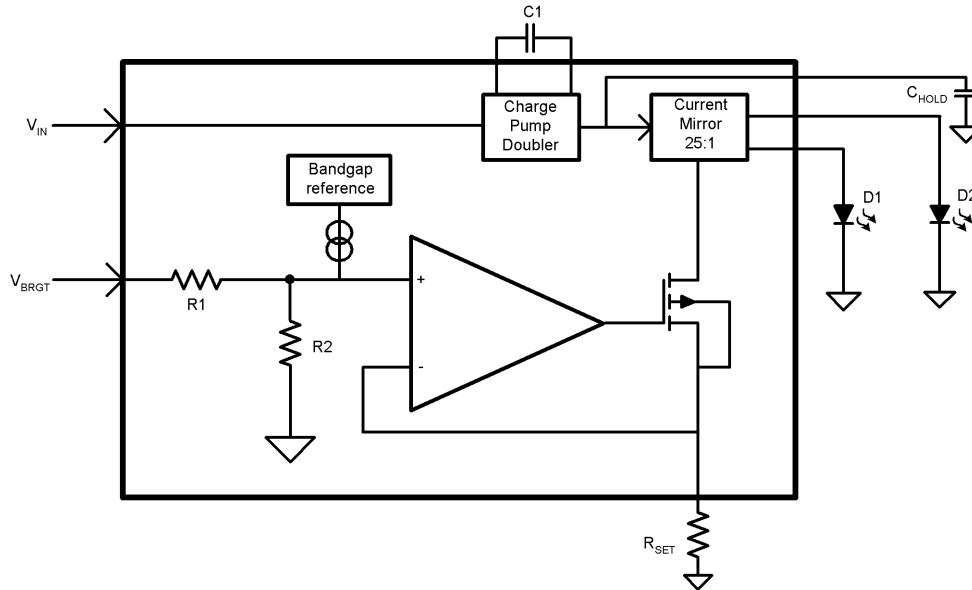

**Figure 14.**

## CIRCUIT DESCRIPTION

The LM2791 provides two matched current sources for driving high forward voltage drop LEDs from Li-Ion battery sources. The device has on-chip current regulators which are composed of current mirrors with a 25 to 1 ratio. The mirrors control the LED current without using current limiting resistors in the LED current path. The device can drive up to a total of 36mA through the LEDs.

The LED brightness can be controlled by both analog and or digital methods. The digital technique uses a PWM (Pulse Width Modulation) signal applied to the shutdown input. The analog technique applies an analog voltage to the brightness (BRGT) pin (see [Application Information](#)). For lowest cost, the LM2791 can be used for constant brightness by grounding BRGT and enabling the shutdown pin.



## APPLICATION INFORMATION

### SOFT START

LM2791 includes a soft start function to reduce the inrush currents and high peak current during power up of the device. Soft start is implemented internally by ramping the bandgap more slowly than the applied voltage. This is done by holding the bandgap in shutdown for a short time. During soft start, the switch resistances limit the inrush current used to charge the flying and hold capacitors.

### SHUTDOWN MODE

A shutdown pin (SD or /SD) is available to disable the LM2791 and reduce the quiescent current to 1 $\mu$ A maximum. The LM2791 is available with both senses of shutdown polarity.

During normal operation mode of the "-L" options, an active high logic signal to the  $\overline{\text{SD}}$  pin or tying the  $\overline{\text{SD}}$  pin to  $V_{\text{IN}}$ , will enable the device. Pulling  $\overline{\text{SD}}$  low or connecting  $\overline{\text{SD}}$  to ground will disable the device.

During normal operation mode of the "-H" options, an active low logic signal to the SD pin or tying the SD pin to GND, will enable the device. Pulling SD high or connecting SD to  $V_{\text{IN}}$  will disable the device.

### CAPACITOR SELECTION

Low equivalent series resistance (ESR) capacitors such as X5R or X7R are recommended to be used for  $C_{\text{IN}}$ , C1, C2, and  $C_{\text{HOLD}}$  for best performance. Ceramic capacitors with less than or equal to 0.3 ohms ESR value are recommended for this application. [Table 1](#) below lists suggested capacitor suppliers for the typical application circuit.

**Table 1. Low ESR Capacitor Manufactures**

Manufacturer	Contact	website
TDK	(847) 803 6100	<a href="http://www.component.tdk.com">www.component.tdk.com</a>
MuRata	(800) 831 9172	<a href="http://www.murata.com">www.murata.com</a>
Taiyo Yuden	(800) 348 2496	<a href="http://www.t-yuden.com">www.t-yuden.com</a>

## SCHOTTKY DIODE SELECTION

A schottky diode (D1) must be used between  $V_{IN}$  and  $P_{OUT}$  for proper operation. During start-up, the low voltage drop across this diode is used to charge  $C_{OUT}$  and start the oscillator. It is necessary to protect the device from turning-on its own parasitic diode and potentially latching-up. As a result, it is important to select a schottky diode that will carry at least 200mA or higher current to charge the output capacitor during start-up. A schottky diode like 1N5817 can be used for most applications or a surface mount diode such as BAT54-series and MA2J704 used to reduce the circuit size. [Table 2](#) below lists suggested schottky diode manufactures.

**Table 2. Diode Manufactures**

Manufacturer	Contact	Schottky Diodes
ON Semiconductor	(800) 344 3860	<a href="http://www.onsemi.com">www.onsemi.com</a>
Phillips Semiconductors	(800) 234 7381	<a href="http://www.philipssemiconduc.com">www.philipssemiconduc.com</a>
Panasonic Semiconductor	(408) 945 5622	<a href="http://www.panasonic.com">www.panasonic.com</a>

## LED SELECTION

The LM2791 is designed to drive LEDs with a forward voltage of about 3.0V to 4.0V or higher. The typical and maximum  $V_F$  depends highly on the manufacturer and their technology. [Table 3](#) lists two suggested manufactures and example part numbers. Each supplier makes many LEDs that work well with the LM2791. The LEDs suggested below are in a surface mount package and TOPLED or SIDEVIEW configuration with a maximum forward current of 20mA. These diodes also come in SIDELED or SIDEVIEW configuration and various chromaticity groups. For applications that demand color and brightness matching, care must be taken to select LEDs from the same chromaticity group. Forward current matching is assured over the LED process variations due to the constant current output of the LM2791. For best fit selection for an application, consult the manufacturer for detailed information.

**Table 3. White LED Selection:**

Component	Manufacture	Contact
LWT673/LWT67C	Osram	<a href="http://www.osram-os.com">www.osram-os.com</a>
NSCW100/ NSCW215	Nichia	<a href="http://www.nichia.com">www.nichia.com</a>

## $I_{SET}$ PIN

An external resistor,  $R_{SET}$ , sets the mirror current that is required to provide a constant current through the LEDs. The current through  $R_{SET}$  and the LED is set by the internal current mirror circuitry with a ratio of 25:1. The currents through each LED are matched within 0.3%.  $R_{SET}$  should be chosen not to exceed the maximum current delivery capability of the device. [Table 4](#) shows a list of  $R_{SET}$  values when maximum BRGT = 0V is applied. For other BRGT voltages,  $R_{SET}$  can be calculated using this formula:

$$R_{SET} = (((BRGT * 0.42) + V_{OFFSET})) / (I_{LED}) * 25 \quad (1)$$

**Table 4.  $R_{SET}$  Selections ( when BRGT pin = 0V)**

$I_{LED}$ per LED	* $R_{SET}$
15mA	330 $\Omega$
10mA	500 $\Omega$
5mA	1K

### Calculation of LED Current When Grounding BRGT:

$$V_{IN} = 3.6V$$

$$V_{OFFSET} = 200mV(\text{Reference Voltage})$$

$$R_{SET} = 330\Omega$$

$$I_{LED} = (V_{OFFSET}/R_{SET}) * 25$$

$$I_{LED} = (200mV/330) * 25 = 15mA$$

### BRGT PIN

The BRGT pin can be used to smoothly vary the brightness of the White LEDs. In the LM2791, current on BRGT is connected to an internal resistor divider which gives a factor 0.42 and summed with an offset voltage from the internal bandgap (200mV). This voltage is fed to the operational amplifier that controls the current through the mirror resistor  $R_{SET}$ . The nominal range on BRGT is 0V to 3V. Care must be taken to prevent voltages on BRGT that cause LED current to exceed 36mA. Although this will not cause damage to the IC, it will not meet the specifications listed in the Electrical Characteristics.

Table 5 shows the current through each LED for the LM2791 with various BRGT and  $R_{SET}$  values.

### Calculation of LED Current When BRGT Pin > 0:

$$R_{SET} = 2000\Omega$$

$$BRGT = 2.5V$$

$$V_{OFFSET} = 200mV(\text{Reference Voltage})$$

$$I_{LED} = (((BRGT * 0.42) + V_{OFFSET}) / R_{SET}) * 25$$

$$I_{LED} = (((2.5 * 0.42) + 0.20) / 2000) * 25 = 15.6mA$$

**Table 5. LED Current When Using BRGT Input<sup>(1)</sup>**

$R_{SET}$ ( $\Omega$ )	1000 $\Omega$	1500 $\Omega$	2000 $\Omega$	2500 $\Omega$
BRGT (V)	$I_{LED}$ (mA)	$I_{LED}$ (mA)	$I_{LED}$ (mA)	$I_{LED}$ (mA)
0.5	10.25	6.84	5.10	4.1
1.0	15.5	10.3	7.75	6.2
1.5	<b>20.75</b>	13.8	10.37	8.3
2.0	<b>26</b>	17.3	13.00	10.4
2.5	<b>31.25</b>	<b>20.80</b>	15.6	12.5
3.0	<b>36.5</b>	<b>24.3</b>	<b>18.3</b>	14.6

(1) Values Highlighted in Boldface exceeded maximum current range of the device if both LEDs are in use.

### BRIGHTNESS CONTROL USING PWM

Brightness control can be implemented by pulsing a signal at the SD pin. The recommended signal should be between 100Hz to 1kHz. If the operating PWM frequency is much less than 100Hz, flicker may be seen in the LEDs. Likewise, if frequency is much higher, brightness in the LEDs will not be linear. When a PWM signal is used to drive the SD pin of the LM2791, connect BRGT pin to a maximum of GND.  $R_{SET}$  value is selected using the above  $I_{SET}$  equation as if BRGT pin is used. The brightness is controlled by increasing and decreasing the duty cycle of the PWM. Zero duty cycle will turn off the brightness and a 50% duty cycle waveform produces an average current of 7.5mA if  $R_{SET}$  is set to produce a maximum LED current of 15mA. So the LED current varies linearly with the duty cycle.

## PARALLEL Dx OUTPUTS FOR INCREASED CURRENT DRIVE

Outputs D1 and D2 may be connected together to drive a single LED. In such a configuration, two parallel current sources of equal value drive the single LED.  $R_{SET}$  and  $V_{BRGT}$  should be chosen so that the current through each of the outputs is programmed to 50% of the total desired LED current. For example, if 30mA is the desired drive current for the single LED,  $R_{SET}$  and  $V_{BRGT}$  should be selected so that the current through each of the outputs is 15mA. Connecting the outputs in parallel does not affect internal operation of the LM2791 and has no impact on the Electrical Characteristics and limits previously presented. The available Dx output current, maximum Dx voltage, and all other specifications provided in the [Electrical Characteristics](#) table apply to this parallel output configuration, just as they do to the standard 2-LED application circuit.

## THERMAL PROTECTION

The LM2791 has internal thermal protection circuitry to disable the charge pump if the junction temperature exceeds 150°C. This feature will protect the device from damage due to excessive power dissipation. The device will recover and operate normally when the junction temperature falls below the maximum operating junction temperature of 100°C. It is important to have good thermal conduction with a proper layout to reduce thermal resistance.

## POWER EFFICIENCY

An ideal power efficiency for a voltage doubler switched capacitor converter is given as the output voltage of the doubler over twice the input voltage as follows:

$$\text{Efficiency} = (V_{DIODE} * I_{DIODE}) / (V_{IN} * I_{DIODE} * \text{Gain}) = V_{DIODE} / 2V_{IN} \quad (2)$$

In the case of the LM2791, a more accurate efficiency calculation can be applied as the given formula below.

$$\text{Efficiency} = ((V_{D1} * I_{D1}) + (V_{D2} * I_{D2})) / (I_{SUPPLY} * V_{IN}) \quad (3)$$

It is clear that the efficiency will depend on the supply voltage in the above equation. As such, the lower the supply voltage, the higher the efficiency.

## POWER DISSIPATION

The maximum allowable power dissipation that this package is capable of handling can be determined as follows:

$$P_{DMax} = (T_{JMax} - T_A) / \theta_{JA} \quad (4)$$

where  $T_{JMax}$  is the maximum junction temperature,  $T_A$  is the ambient temperature, and  $\theta_{JA}$  is the junction-to-ambient thermal resistance of the specified package.

The actual power dissipation of the device can be calculated using this equation:

$$P_{Dissipation} = (2V_{IN} - V_{DIODE}) * I_{LOAD} \quad (5)$$

As an example, if  $V_{IN}$  in the target application is 4.2V,  $V_{DIODE} = 3.0V$  and worst case current consumption is 32mA (16mA for each diode).

$$P_{Dissipation} = ((2 * 4.2) - 3.0) * 0.032 = 173mW \quad (6)$$

Power dissipation must be less than that allowed by the package. Please refer to the Absolute Maximum Rating of the LM2791.

## PCB LAYOUT CONSIDERATIONS

The WSON is a leadframe based Chip Scale Package (CSP) with very good thermal properties. This package has an exposed DAP (die attach pad) at the center of the package measuring 2.0mm x 1.2mm. The main advantage of this exposed DAP is to offer lower thermal resistance when it is soldered to the thermal land on the PCB. For PCB layout, a 1:1 ratio between the package and the PCB thermal land is highly recommended. To further enhance thermal conductivity, the PCB thermal land may include vias to a ground plane. For more detailed instructions on mounting WSON packages, please refer to Application Note AN-1187. ([SNOA401](#))

### REVISION HISTORY

Changes from Revision L (May 2013) to Revision M	Page
• Changed layout of National Data Sheet to TI format .....	11

**PACKAGING INFORMATION**

Orderable Device	Status (1)	Package Type	Package Drawing	Pins	Package Qty	Eco Plan (2)	Lead/Ball Finish (6)	MSL Peak Temp (3)	Op Temp (°C)	Device Marking (4/5)	Samples
LM2791LD-L	NRND	WSON	NGY	10		TBD	Call TI	Call TI	-30 to 85	SNB	
LM2791LD-L/NOPB	OBSOLETE	WSON	NGY	10		TBD	Call TI	Call TI	-30 to 85	SNB	

(1) The marketing status values are defined as follows:

**ACTIVE:** Product device recommended for new designs.

**LIFEBUY:** TI has announced that the device will be discontinued, and a lifetime-buy period is in effect.

**NRND:** Not recommended for new designs. Device is in production to support existing customers, but TI does not recommend using this part in a new design.

**PREVIEW:** Device has been announced but is not in production. Samples may or may not be available.

**OBSOLETE:** TI has discontinued the production of the device.

(2) Eco Plan - The planned eco-friendly classification: Pb-Free (RoHS), Pb-Free (RoHS Exempt), or Green (RoHS & no Sb/Br) - please check <http://www.ti.com/productcontent> for the latest availability information and additional product content details.

**TBD:** The Pb-Free/Green conversion plan has not been defined.

**Pb-Free (RoHS):** TI's terms "Lead-Free" or "Pb-Free" mean semiconductor products that are compatible with the current RoHS requirements for all 6 substances, including the requirement that lead not exceed 0.1% by weight in homogeneous materials. Where designed to be soldered at high temperatures, TI Pb-Free products are suitable for use in specified lead-free processes.

**Pb-Free (RoHS Exempt):** This component has a RoHS exemption for either 1) lead-based flip-chip solder bumps used between the die and package, or 2) lead-based die adhesive used between the die and leadframe. The component is otherwise considered Pb-Free (RoHS compatible) as defined above.

**Green (RoHS & no Sb/Br):** TI defines "Green" to mean Pb-Free (RoHS compatible), and free of Bromine (Br) and Antimony (Sb) based flame retardants (Br or Sb do not exceed 0.1% by weight in homogeneous material)

(3) MSL, Peak Temp. - The Moisture Sensitivity Level rating according to the JEDEC industry standard classifications, and peak solder temperature.

(4) There may be additional marking, which relates to the logo, the lot trace code information, or the environmental category on the device.

(5) Multiple Device Markings will be inside parentheses. Only one Device Marking contained in parentheses and separated by a "-" will appear on a device. If a line is indented then it is a continuation of the previous line and the two combined represent the entire Device Marking for that device.

(6) Lead/Ball Finish - Orderable Devices may have multiple material finish options. Finish options are separated by a vertical ruled line. Lead/Ball Finish values may wrap to two lines if the finish value exceeds the maximum column width.

**Important Information and Disclaimer:** The information provided on this page represents TI's knowledge and belief as of the date that it is provided. TI bases its knowledge and belief on information provided by third parties, and makes no representation or warranty as to the accuracy of such information. Efforts are underway to better integrate information from third parties. TI has taken and continues to take reasonable steps to provide representative and accurate information but may not have conducted destructive testing or chemical analysis on incoming materials and chemicals. TI and TI suppliers consider certain information to be proprietary, and thus CAS numbers and other limited information may not be available for release.

In no event shall TI's liability arising out of such information exceed the total purchase price of the TI part(s) at issue in this document sold by TI to Customer on an annual basis.





## IMPORTANT NOTICE

Texas Instruments Incorporated and its subsidiaries (TI) reserve the right to make corrections, enhancements, improvements and other changes to its semiconductor products and services per JESD46, latest issue, and to discontinue any product or service per JESD48, latest issue. Buyers should obtain the latest relevant information before placing orders and should verify that such information is current and complete. All semiconductor products (also referred to herein as "components") are sold subject to TI's terms and conditions of sale supplied at the time of order acknowledgment.

TI warrants performance of its components to the specifications applicable at the time of sale, in accordance with the warranty in TI's terms and conditions of sale of semiconductor products. Testing and other quality control techniques are used to the extent TI deems necessary to support this warranty. Except where mandated by applicable law, testing of all parameters of each component is not necessarily performed.

TI assumes no liability for applications assistance or the design of Buyers' products. Buyers are responsible for their products and applications using TI components. To minimize the risks associated with Buyers' products and applications, Buyers should provide adequate design and operating safeguards.

TI does not warrant or represent that any license, either express or implied, is granted under any patent right, copyright, mask work right, or other intellectual property right relating to any combination, machine, or process in which TI components or services are used. Information published by TI regarding third-party products or services does not constitute a license to use such products or services or a warranty or endorsement thereof. Use of such information may require a license from a third party under the patents or other intellectual property of the third party, or a license from TI under the patents or other intellectual property of TI.

Reproduction of significant portions of TI information in TI data books or data sheets is permissible only if reproduction is without alteration and is accompanied by all associated warranties, conditions, limitations, and notices. TI is not responsible or liable for such altered documentation. Information of third parties may be subject to additional restrictions.

Resale of TI components or services with statements different from or beyond the parameters stated by TI for that component or service voids all express and any implied warranties for the associated TI component or service and is an unfair and deceptive business practice. TI is not responsible or liable for any such statements.

Buyer acknowledges and agrees that it is solely responsible for compliance with all legal, regulatory and safety-related requirements concerning its products, and any use of TI components in its applications, notwithstanding any applications-related information or support that may be provided by TI. Buyer represents and agrees that it has all the necessary expertise to create and implement safeguards which anticipate dangerous consequences of failures, monitor failures and their consequences, lessen the likelihood of failures that might cause harm and take appropriate remedial actions. Buyer will fully indemnify TI and its representatives against any damages arising out of the use of any TI components in safety-critical applications.

In some cases, TI components may be promoted specifically to facilitate safety-related applications. With such components, TI's goal is to help enable customers to design and create their own end-product solutions that meet applicable functional safety standards and requirements. Nonetheless, such components are subject to these terms.

No TI components are authorized for use in FDA Class III (or similar life-critical medical equipment) unless authorized officers of the parties have executed a special agreement specifically governing such use.

Only those TI components which TI has specifically designated as military grade or "enhanced plastic" are designed and intended for use in military/aerospace applications or environments. Buyer acknowledges and agrees that any military or aerospace use of TI components which have **not** been so designated is solely at the Buyer's risk, and that Buyer is solely responsible for compliance with all legal and regulatory requirements in connection with such use.

TI has specifically designated certain components as meeting ISO/TS16949 requirements, mainly for automotive use. In any case of use of non-designated products, TI will not be responsible for any failure to meet ISO/TS16949.

### Products

Audio	<a href="http://www.ti.com/audio">www.ti.com/audio</a>
Amplifiers	<a href="http://amplifier.ti.com">amplifier.ti.com</a>
Data Converters	<a href="http://dataconverter.ti.com">dataconverter.ti.com</a>
DLP® Products	<a href="http://www.dlp.com">www.dlp.com</a>
DSP	<a href="http://dsp.ti.com">dsp.ti.com</a>
Clocks and Timers	<a href="http://www.ti.com/clocks">www.ti.com/clocks</a>
Interface	<a href="http://interface.ti.com">interface.ti.com</a>
Logic	<a href="http://logic.ti.com">logic.ti.com</a>
Power Mgmt	<a href="http://power.ti.com">power.ti.com</a>
Microcontrollers	<a href="http://microcontroller.ti.com">microcontroller.ti.com</a>
RFID	<a href="http://www.ti-rfid.com">www.ti-rfid.com</a>
OMAP Applications Processors	<a href="http://www.ti.com/omap">www.ti.com/omap</a>
Wireless Connectivity	<a href="http://www.ti.com/wirelessconnectivity">www.ti.com/wirelessconnectivity</a>

### Applications

Automotive and Transportation	<a href="http://www.ti.com/automotive">www.ti.com/automotive</a>
Communications and Telecom	<a href="http://www.ti.com/communications">www.ti.com/communications</a>
Computers and Peripherals	<a href="http://www.ti.com/computers">www.ti.com/computers</a>
Consumer Electronics	<a href="http://www.ti.com/consumer-apps">www.ti.com/consumer-apps</a>
Energy and Lighting	<a href="http://www.ti.com/energy">www.ti.com/energy</a>
Industrial	<a href="http://www.ti.com/industrial">www.ti.com/industrial</a>
Medical	<a href="http://www.ti.com/medical">www.ti.com/medical</a>
Security	<a href="http://www.ti.com/security">www.ti.com/security</a>
Space, Avionics and Defense	<a href="http://www.ti.com/space-avionics-defense">www.ti.com/space-avionics-defense</a>
Video and Imaging	<a href="http://www.ti.com/video">www.ti.com/video</a>

### TI E2E Community

[e2e.ti.com](http://e2e.ti.com)

## Looking for pricing, stock, or lifecycle information?

Click below to explore more details on WIN SOURCE:

-  [View LM2791LD-L/NOPB on WIN SOURCE](#)
-  [Texas Instruments](#) Information

## Optimize Your Supply Chain with WIN SOURCE Solutions

-  Global Sourcing Solution
-  Obsolete Management
-  Cost Control Management
-  Shortage Management
-  Alternative Solution
-  Excess Inventory Management