



**THE DATASHEET OF
SN65HVDA195QDRQ1**



SN65HVDA195-Q1 Automotive LIN and Most ECL Physical Interface

1 Features

- LIN Physical layer specification revision 2.0 compliant and conforms to SAEJ2602 recommended practice for LIN
- LIN Bus speed up to 20-kbps LIN specified maximum and MOST ECL speeds down to 0 Baud
- Supports ISO9141 (k-line)
- Qualified for automotive applications
- Sleep mode: ultra low current consumption, allows wake-up events from LIN bus, wake-up Input (external switch), or host microcontroller
- High-speed receive capable
- ESD protection to ± 12 kV (human body model) on LIN pin
- LIN pin handles voltage from -40 V to 40 V
- Survives transient damage in automotive environment (ISO 7637)
- Extended operation with supply from 7 V to 27 V DC (LIN specification 7 V to 18 V)
- Interfaces to microcontroller with 5-V or 3.3-V I/O pins
- Wake-up request on RXD pin
- Control of external voltage regulator (INH pin)
- Integrated pullup resistor and series diode for LIN responder applications
- Low electromagnetic emission (EME), high electromagnetic immunity (EMI)
- Bus terminal short circuit protected for short-to-battery or short-to-ground
- Thermally protected
- Ground disconnection fail-safe at system level
- Ground shift operation at system level
- Unpowered node does not disturb the network

2 Applications

- Automotive
- Industrial sensing
- White goods distributed control

3 Description

The SN65HVDA195 device is the Local Interconnect Network (LIN) physical interface and MOST ECL interface, which integrates the serial transceiver with wake-up and protection features. The bus is a single-wire bidirectional bus typically used for low-speed in-vehicle networks using data rates to 20 kbps. The device can transmit with an effective data rate of 0 kbps because it does not have dominant state time-out. The protocol output data stream on TXD is converted by the SN65HVDA195 into the bus signal through a current-limited wave-shaping driver as outlined by the LIN physical layer specification revision 2.0. The receiver converts the data stream from the bus and outputs the data stream through RXD. The bus has two states: dominant state (voltage near ground) and the recessive state (voltage near battery). In the recessive state, the bus is pulled high by the SN65HVDA195 internal pullup resistor and series diode, so no external pullup components are required for responder applications. Commander applications require an external pullup resistor (1 k Ω) plus a series diode per the LIN specification.

Device Information

PART NUMBER	PACKAGE ⁽¹⁾	BODY SIZE (NOM)
SN65HVDA195-Q1	SOIC (8)	4.90 mm × 3.91 mm

(1) For all available packages, see the orderable addendum at the end of the data sheet.

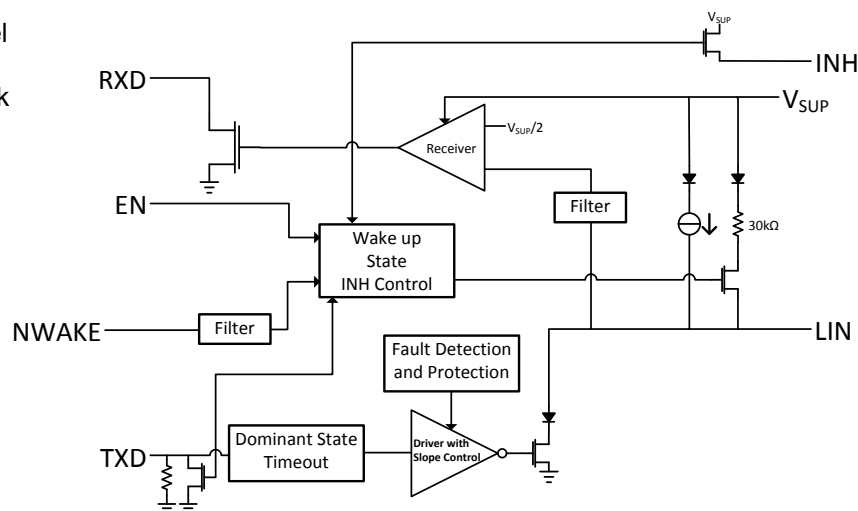

Simplified Block Diagram



Table of Contents

1 Features	1	9.1 Overview.....	10
2 Applications	1	9.2 Functional Block Diagram.....	10
3 Description	1	9.3 Feature Description.....	10
4 Revision History	2	9.4 Device Functional Modes.....	12
5 Description (continued)	3	10 Application and Implementation	15
6 Pin Configuration and Functions	3	10.1 Application Information.....	15
7 Specifications	4	11 Device and Documentation Support	18
7.1 Absolute Maximum Ratings.....	4	11.1 Receiving Notification of Documentation Updates..	18
7.2 ESD Ratings.....	4	11.2 Support Resources.....	18
7.3 Recommended Operating Conditions.....	4	11.3 Trademarks.....	18
7.4 Thermal Information.....	4	11.4 Electrostatic Discharge Caution.....	18
7.5 Electrical Characteristics.....	5	11.5 Glossary.....	18
7.6 Typical Characteristics.....	8	12 Mechanical, Packaging, and Orderable Information	18
8 Parameter Measurement Information	9		
9 Detailed Description	10		

4 Revision History

NOTE: Page numbers for previous revisions may differ from page numbers in the current version.

Changes from Revision B (March 2015) to Revision C (June 2022) Page

- Changed all instances of legacy terminology to commander and responder where mentioned.....1

Changes from Revision A (October 2009) to Revision B (March 2015) Page

- Added *Pin Configuration and Functions* section, *ESD Ratings* table, *Feature Description* section, *Device Functional Modes*, *Application and Implementation* section, *Power Supply Recommendations* section, *Layout* section, *Device and Documentation Support* section, and *Mechanical, Packaging, and Orderable Information* section 1
- Removed *Ordering Information* table3
- Deleted *Device Comparison* table 0

5 Description (continued)

In sleep mode, the SN65HVDA195 requires low quiescent current while the wake-up circuits remain active. This allows remote wake up through the LIN bus or local wake up through the NWake or EN pins.

The SN65HVDA195 has been designed for operation in the harsh automotive environment. The device can handle LIN bus voltage swings from 40 V down to ground and survive –40 V. The device also prevents back-feed current through LIN to the supply input, in case of a ground shift or supply voltage disconnection. It also features undervoltage, overtemperature, and loss-of-ground protection. In the event of a fault condition, the output is immediately switched off and remains off until the fault condition is removed.

6 Pin Configuration and Functions

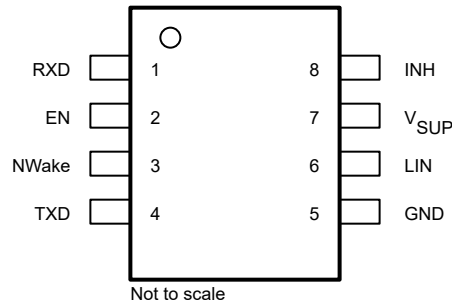

Figure 6-1. D (SOIC) Package 8-Pin (Top View)

Table 6-1. Pin Functions

PIN		TYPE ⁽¹⁾	DESCRIPTION
NO.	NAME		
1	RXD	O	RXD output (open drain) interface reporting state of LIN bus voltage
2	EN	I	Enable input
3	NWake	I	High voltage input for device wake up
4	TXD	I	TXD input interface to control state of LIN output
5	GND	GND	Ground
6	LIN	I/O	LIN bus single-wire transmitter and receiver
7	V _{SUP}	Supply	Device supply voltage (connected to battery in series with external reverse blocking diode)
8	INH	O	Inhibit controls external voltage regulator with inhibit input

(1) I = Input, O = Output, I/O = Input or Output, G = Ground.

7 Specifications

7.1 Absolute Maximum Ratings

over operating free-air temperature range (unless otherwise noted)⁽¹⁾

PARAMETER		MIN	MAX	UNIT
V _{SUP} ⁽²⁾	Supply line supply voltage ⁽³⁾	0	40	V
V _{NWake}	NWake DC and transient input voltage (through serial resistor)	-0.3	40	
I _{NWake}	NWake current if due to ground shifts $V_{NWake} \leq V_{GND} - 0.3$ V, thus the current into NWake must be limited through a serial resistance.		-3.6	mA
V _{INH}	INH voltage	-0.3	V _{SUP} + 0.3	V
V _{Logic_Input}	Logic pin input voltage	-0.3	5.5	
V _{LIN}	LIN DC-input voltage	-40	40	
T _A	Operational free-air temperature	-40	125	°C
T _J	Junction temperature	-40	150	°C
T _{SD}	Thermal shutdown		200	°C
T _{SD_HYS}	Thermal shutdown hysteresis		25	°C
T _{stg}	Storage temperature	-40	165	°C

- (1) Stresses beyond those listed under *Absolute Maximum Ratings* may cause permanent damage to the device. These are stress ratings only, which do not imply functional operation of the device at these or any other conditions beyond those indicated under *Recommended Operating Conditions*. Exposure to absolute-maximum-rated conditions for extended periods may affect device reliability.
- (2) All voltage values are with respect to GND.
- (3) The device is specified for operation in the range of V_{SUP} from 7 V to 27 V. Operating the device more than 27 V may significantly raise the junction temperature of the device and system level thermal design must be considered.
- (4) The human body model is a 100-pF capacitor discharged through a 1.5-kΩ resistor into each pin.

7.2 ESD Ratings

		VALUE	UNIT		
V _(ESD)	Electrostatic discharge	Human body model (HBM), per AEC Q100-002 ⁽¹⁾	All pins except LIN and NWake	±4000	V
			Pin LIN	±12000	
			Pin NWake	±11000	
		Charged-device model (CDM), per AEC Q100-011	All pins	±1500	

- (1) AEC Q100-002 indicates that HBM stressing shall be in accordance with the ANSI/ESDA/JEDEC JS-001 specification.

7.3 Recommended Operating Conditions

over operating free-air temperature range (unless otherwise noted)

	MIN	MAX	UNIT
V _{SUP}	7	27	V
T _{AMB}	-40	125	°C

7.4 Thermal Information

THERMAL METRIC ⁽¹⁾		D (SOIC)	UNIT
		8 PINS	
R _{θJA}	Junction-to-ambient thermal resistance	112.5	°C/W
R _{θJC(top)}	Junction-to-case (top) thermal resistance	66.3	°C/W
R _{θJB}	Junction-to-board thermal resistance	52.9	°C/W
ψ _{JT}	Junction-to-top characterization parameter	19.3	°C/W
ψ _{JB}	Junction-to-board characterization parameter	52.4	°C/W

- (1) For more information about traditional and new thermal metrics, see the *Semiconductor and IC Package Thermal Metrics* application report, [SPRA953](#).

7.5 Electrical Characteristics

 $V_{SUP} = 7\text{ V to }27\text{ V}$, $T_A = -40^\circ\text{C to }125^\circ\text{C}$ (unless otherwise noted)

PARAMETER		TEST CONDITIONS	MIN	TYP ⁽¹⁾	MAX	UNIT	
SUPPLY							
	Operational supply voltage ⁽²⁾	Device is operational beyond the LIN 2.0 defined nominal supply line voltage range of $7\text{ V} \leq V_{SUP} \leq 18\text{ V}$	7	14	27	V	
	Nominal supply line voltage	Normal and standby modes	7	14	18		
		Sleep mode	7	12	18		
	V_{SUP} undervoltage threshold			4.8	6		
I_{SUP}	Supply current	Normal mode, EN = High, Bus dominant (total bus load where $R_{LIN} \geq 500\ \Omega$ and $C_{LIN} \leq 10\text{ nF}$ (see Figure 8-1) ⁽³⁾ , INH = V_{SUP} , NWake = V_{SUP}		1.2	7.5	mA	
		Standby mode, EN = low, Bus dominant (total bus load where $R_{LIN} \geq 500\ \Omega$ and $C_{LIN} \leq 10\text{ nF}$ (see Figure 8-1) ⁽³⁾ , INH = V_{SUP} , NWake = V_{SUP}		1	2.1		
		Normal mode, EN = High, Bus recessive, LIN = V_{SUP} , INH = V_{SUP} , NWake = V_{SUP}		450	775	μA	
		Standby mode, EN = Low, Bus recessive, LIN = V_{SUP} , INH = V_{SUP} , NWake = V_{SUP}		450	775		
		Sleep mode, EN = 0, $T_A = -40^\circ\text{C to }95^\circ\text{C}$, $7\text{ V} < V_{SUP} \leq 12\text{ V}$, LIN = V_{SUP} , NWake = V_{SUP}			13		26
		Sleep mode, EN = 0, $T_A = -40^\circ\text{C to }95^\circ\text{C}$, $12\text{ V} < V_{SUP} < 18\text{ V}$, LIN = V_{SUP} , NWake = V_{SUP}					35
ΔI_{SUP}	Delta supply current in sleep mode	Sleep mode, EN = 0, $T_A = -40^\circ\text{C to }95^\circ\text{C}$, Supply line voltage range of $7\text{ V} \leq V_{SUP} \leq 18\text{ V}$, LIN bus voltage: $V_{SUP} - 1.85\text{ V} \leq LIN \leq V_{SUP}$			20		
RXD OUTPUT PIN							
V_O	Output voltage		-0.3		5.5	V	
I_{OL}	Low-level output current, open drain	LIN = 0 V, RXD = 0.4 V	3.5			mA	
I_{IKG}	Leakage current, high-level	LIN = V_{SUP} , RXD = 5 V	-5	0	5	μA	
TXD INPUT PIN							
V_{IL}	Low-level input voltage		-0.3		0.8	V	
V_{IH}	High-level input voltage		2		5.5		
V_{IT}	Input threshold hysteresis voltage		30		500	mV	
	Pulldown resistor		125	350	800	k Ω	
I_{IL}	Low-level input current	TXD = Low	-5	0	5	μA	
LIN PIN (REFERENCED TO V_{SUP})							
V_{OH}	High-level output voltage	LIN recessive, TXD = High, $I_O = 0\text{ mA}$, $V_{SUP} = 14\text{ V}$	$V_{SUP} - 1$			V	
V_{OL}	Low-level output voltage	LIN dominant, TXD = Low, $I_O = 40\text{ mA}$, $V_{SUP} = 14\text{ V}$	0	$0.2 \times V_{SUP}$			
$R_{responder}$	Pullup resistor to V_{SUP}	Normal and standby modes	20	30	60	k Ω	
	Pullup current source to V_{SUP}	Sleep mode, $V_{SUP} = 14\text{ V}$, LIN = GND	-2		-20	μA	
I_L	Limiting current	TXD = 0 V	45	160	220	mA	
		TXD = 0 V, $T_A = -10^\circ\text{C to }125^\circ\text{C}$			200		

7.5 Electrical Characteristics (continued)

$V_{SUP} = 7\text{ V to }27\text{ V}$, $T_A = -40^\circ\text{C to }125^\circ\text{C}$ (unless otherwise noted)

PARAMETER		TEST CONDITIONS	MIN	TYP ⁽¹⁾	MAX	UNIT
I_{LKG}	Leakage current	$LIN = V_{SUP}$	-5	0	5	μA
I_{LKG}	Leakage current, loss of supply	$7\text{ V} < LIN \leq 12\text{ V}$, $V_{SUP} = \text{GND}$			5	
		$12\text{ V} < LIN < 18\text{ V}$, $V_{SUP} = \text{GND}$			10	
V_{IL}	Low-level input voltage	LIN dominant			$0.4 \times V_{SUP}$	V
V_{IH}	High-level input voltage	LIN recessive	$0.6 \times V_{SUP}$			
V_{IT}	Input threshold voltage		$0.4 \times V_{SUP}$	$0.5 \times V_{SUP}$	$0.6 \times V_{SUP}$	
V_{hys}	Hysteresis voltage		$0.05 \times V_{SUP}$		$0.175 \times V_{SUP}$	
V_{IL}	Low-level input voltage for wakeup				$0.4 \times V_{SUP}$	
EN PIN						
V_{IL}	Low-level input voltage		-0.3		0.8	V
V_{IH}	High-level input voltage		2		5.5	
V_{hys}	Hysteresis voltage		30		500	mV
	Pulldown resistor		125	350	800	k Ω
I_{IL}	Low-level input current	EN = Low	-5	0	5	μA
INH PIN						
V_o	DC output voltage		-0.3		$V_{SUP} + 0.3$	V
R_{on}	On state resistance	Between V_{SUP} and INH, INH = 2-mA drive, Normal or standby mode		35	85	Ω
I_{IKG}	Leakage current	Low-power mode, $0 < INH < V_{SUP}$	-5	0	5	μA
NWAKE PIN						
V_{IL}	Low-level input voltage		-0.3		$V_{SUP} - 3.3$	V
V_{IH}	High-level input voltage		$V_{SUP} - 1$		$V_{SUP} + 0.3$	
	Pullup current	NWAKE = 0 V	-45	-10	-2	μA
I_{IKG}	Leakage current	$V_{SUP} = \text{NWAKE}$	-5	0	5	
THERMAL SHUTDOWN						
	Shutdown junction thermal temperature			190		$^\circ\text{C}$
AC CHARACTERISTICS						
D1	Duty cycle 1 ⁽⁴⁾	$TH_{REC(max)} = 0.744 \times V_{SUP}$, $TH_{DOM(max)} = 0.581 \times V_{SUP}$, $V_{SUP} = 7\text{ V to }18\text{ V}$, $t_{BIT} = 50\ \mu\text{s}$ (20 kbps), $D1 = t_{Bus_rec(min)} / (2 \times t_{BIT})$. See Figure 7-1	0.396			
D2	Duty cycle 2 ⁽⁴⁾	$TH_{REC(min)} = 0.422 \times V_{SUP}$, $TH_{DOM(min)} = 0.284 \times V_{SUP}$, $V_{SUP} = 7.6\text{ V to }18\text{ V}$, $t_{BIT} = 50\ \mu\text{s}$ (20 kbps), $D2 = t_{Bus_rec(max)} / (2 \times t_{BIT})$. See Figure 7-1			0.581	
D3	Duty cycle 3 ⁽⁴⁾	$TH_{REC(max)} = 0.778 \times V_{SUP}$, $TH_{DOM(max)} = 0.616 \times V_{SUP}$, $V_{SUP} = 7\text{ V to }18\text{ V}$, $t_{BIT} = 96\ \mu\text{s}$ (10.4 kbps), $D3 = t_{Bus_rec(min)} / (2 \times t_{BIT})$. See Figure 7-1	0.417			

7.5 Electrical Characteristics (continued)

$V_{SUP} = 7\text{ V to }27\text{ V}$, $T_A = -40^\circ\text{C to }125^\circ\text{C}$ (unless otherwise noted)

PARAMETER	TEST CONDITIONS	MIN	TYP ⁽¹⁾	MAX	UNIT
D4 Duty cycle 4 ⁽⁴⁾	$TH_{REC(min)} = 0.389 \times V_{SUP}$, $TH_{DOM(min)} = 0.251 \times V_{SUP}$, $V_{SUP} = 7.6\text{ V to }18\text{ V}$, $t_{BIT} = 96\ \mu\text{s}$ (10.4 kbps), $D4 = t_{Bus_rec(max)} / (2 \times t_{BIT})$. See Figure 7-1			0.59	
t_{rx_pdr} Receiver rising propagation delay time	$R_{RXD} = 2.4\text{ k}\Omega$, $C_{RXD} = 20\text{ pF}$ See Figure 7-2 See Figure 8-1			6	
t_{rx_pdf} Receiver falling propagation delay time	$R_{RXD} = 2.4\text{ k}\Omega$, $C_{RXD} = 20\text{ pF}$ See Figure 7-2 See Figure 8-1			6	
t_{rx_sym} Symmetry of receiver propagation delay time	rising edge with respect to falling edge ($t_{rx_sym} = t_{rx_pdf} - t_{rx_pdr}$) $R_{RXD} = 2.4\text{ k}\Omega$, $C_{RXD} = 20\text{ pF}$ See Figure 7-2 See Figure 8-1	-2		2	μs
t_{NWake} NWake filter time for local wakeup	See Figure 9-4	25	50	150	
t_{LINBUS} LIN wake-up filter time (dominant time for wakeup through LIN bus)	See Figure 9-3	25	50	150	
$t_{go_to_operate}$	See Figure 9-2 to Figure 9-3		0.5	1	

- (1) Typical values are given for $V_{SUP} = 14\text{ V}$ at 25°C , except for low power mode where typical values are given for $V_{SUP} = 12\text{ V}$ at 25°C .
- (2) All voltages are defined with respect to ground; positive currents flow into the SN65HVDA195 device.
- (3) In the dominant state, the supply current increases as the supply voltage increases due to the integrated LIN responder termination resistance. At higher voltages the majority of supply current is through the termination resistance. The minimum resistance of the LIN responder termination is $20\text{ k}\Omega$, so the maximum supply current attributed to the termination is:
 $I_{SUP(dom)max\ termination} \approx (V_{SUP} - (V_{LIN_Dominant} + 0.7\text{ V})) / 20\text{ k}\Omega$
- (4) Duty cycles: LIN driver bus load conditions (C_{LINBUS} , R_{LINBUS}): Load1 = 1 nF , $1\text{ k}\Omega$; Load2 = 10 nF , $500\ \Omega$. Duty cycles 3 and 4 are defined for 10.4-kbps operation. The SN65HVDA195 also meets these lower data rate requirements, while it is capable of the higher speed 20-kbps operation as specified by Duty cycles 1 and 2. SAEJ2602 derives propagation delay equations from the LIN 2.0 duty cycle definitions, for details see the SAEJ2602 specification.

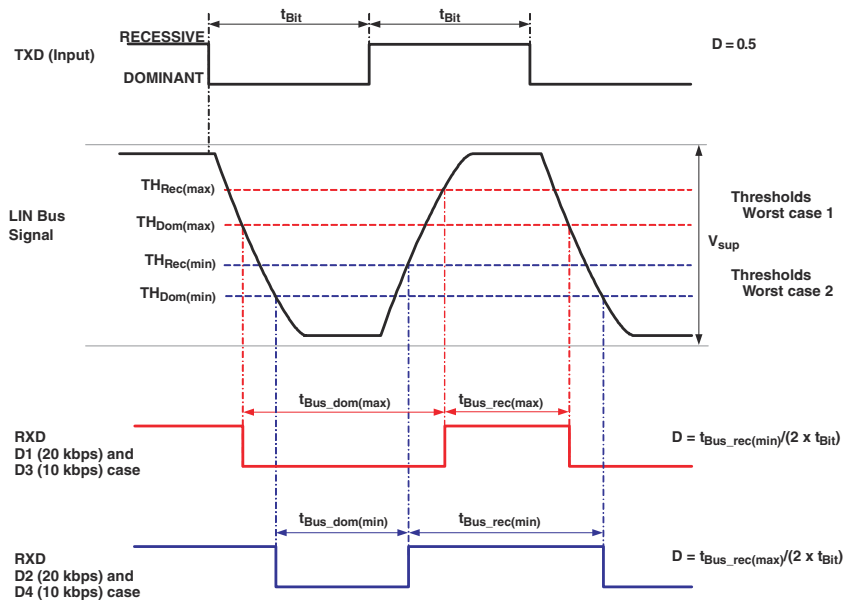

Figure 7-1. Definition of Bus Timing Parameters

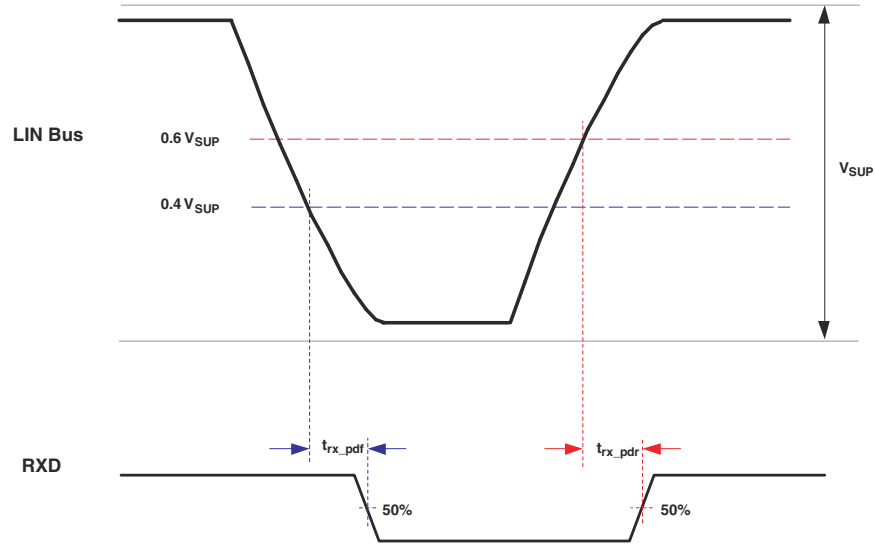

Figure 7-2. Propagation Delay

7.6 Typical Characteristics

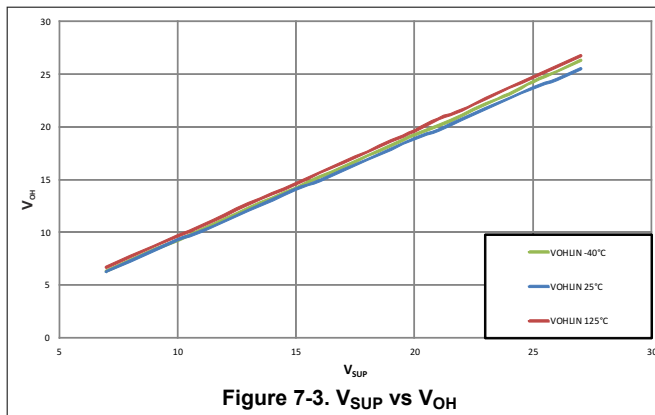

Figure 7-3. V_{SUP} vs V_{OH}

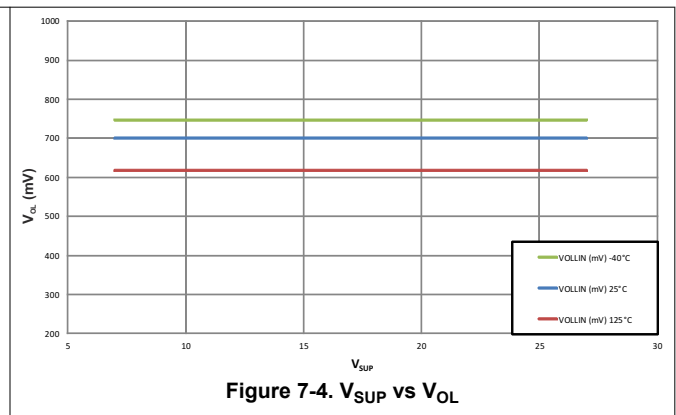

Figure 7-4. V_{SUP} vs V_{OL}

8 Parameter Measurement Information

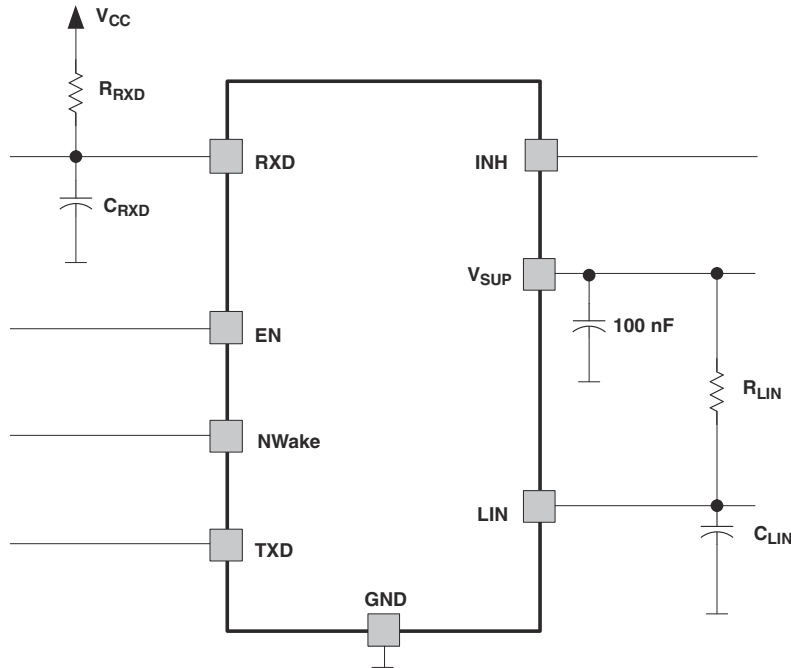

Figure 8-1. Test Circuit for AC Characteristics

9 Detailed Description

9.1 Overview

The SN65HVDA195-Q1 LIN transceiver is a LIN (Local Interconnect Network) physical layer transceiver which integrates a serial transceiver with wake up and protection features. The LIN bus is a single wire, bi-directional bus that typically is used in low speed in vehicle networks with data rates that range from 2.4 kbps to 20 kbps

9.2 Functional Block Diagram

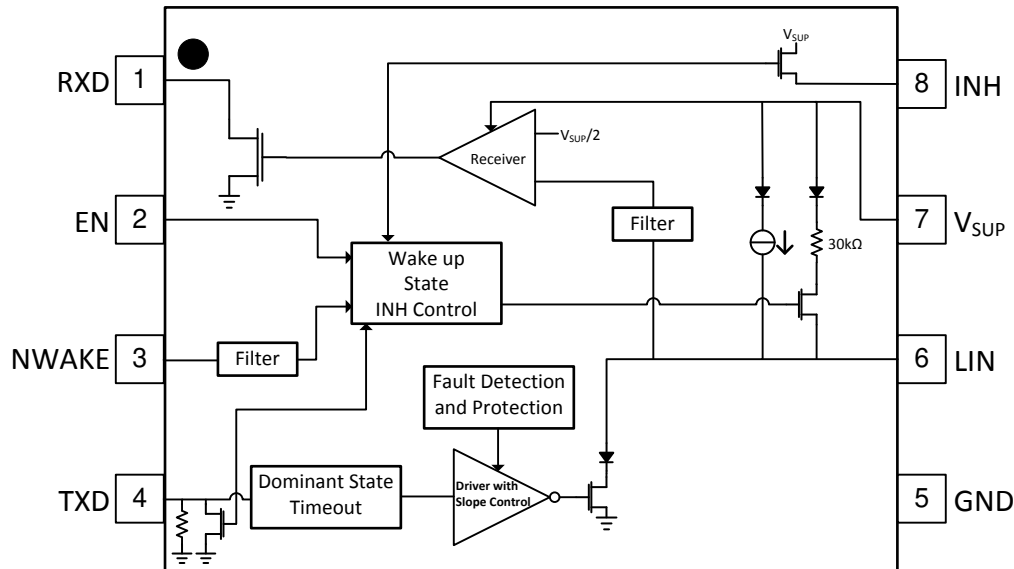

9.3 Feature Description

9.3.1 Local Interconnect Network (LIN) Bus

This I/O pin is the single-wire LIN bus transmitter and receiver.

9.3.1.1 Transmitter Characteristics

The driver is a low-side transistor with internal current limitation and thermal shutdown. There is an internal 30-kΩ pullup resistor with a serial diode structure to V_{SUP} , so no external pullup components are required for LIN responder mode applications. An external pullup resistor of 1 kΩ, plus a series diode to V_{SUP} must be added when the device is used for commander node applications.

Voltage on LIN can go from -40-V to 40-V DC without any currents other than through the pullup resistance. There are no reverse currents from the LIN bus to supply (V_{SUP}), even in the event of a ground shift or loss of supply (V_{SUP}).

The LIN thresholds and AC parameters are LIN Protocol Specification Revision 2.0 compliant.

During a thermal shut down condition, the driver is disabled.

9.3.1.2 Receiver Characteristics

The receiver's characteristic thresholds are ratio-metric with the device supply pin. Typical thresholds are 50%, with a hysteresis from 5% to 17.5% of supply.

The receiver is capable of receiving higher data rates (>100 kbps) than supported by LIN or SAEJ2602 specifications. This allows the SN65HVDA195 to be used for high-speed downloads at end-of-line production or other applications. The actual data rates achievable depend on system time constants (bus capacitance and pullup resistance) and driver characteristics used in the system.

9.3.2 Transmit Input (TXD)

TXD is the interface to the MCU's LIN protocol controller or SCI/UART used to control the state of the LIN output. When TXD is low, the LIN output is dominant (near ground). When TXD is high, the LIN output is recessive (near battery). The TXD input structure is compatible with microcontrollers with 3.3-V and 5-V I/O. TXD has an internal pulldown resistor. This device does not have a TXD dominant time-out protection circuit so that low data rates may be used.

9.3.3 Receive Output (RXD)

RXD is the interface to the MCU's LIN protocol controller or SCI/UART, which reports the state of the LIN bus voltage. LIN recessive (near battery) is represented by a high level on RXD and LIN dominant (near ground) is represented by a low level on RXD. The RXD output structure is an open-drain output stage. This allows the SN65HVDA195 to be used with 3.3-V and 5-V I/O microcontrollers. If the microcontroller's RXD pin does not have an integrated pullup, an external pullup resistor to the microcontroller I/O supply voltage is required.

9.3.3.1 RXD Wake-Up Request

When the SN65HVDA195 has been in low-power mode and encounters a wake-up event from the LIN bus or NWake pin, RXD goes low, while the device enters and remains in standby mode (until EN is reasserted high and the device enters normal mode).

9.3.4 Supply Voltage (V_{SUP})

V_{SUP} is the SN65HVDA195 device power supply pin. V_{SUP} is connected to the battery through an external reverse battery blocking diode. The characterized operating voltage range for the SN65HVDA195 is from 7 V to 27 V. V_{SUP} is protected for harsh automotive conditions up to 40 V.

The device contains a reset circuit to avoid false bus messages during undervoltage conditions when V_{SUP} is less than V_{SUP_UNDER} .

9.3.5 Ground (GND)

GND is the SN65HVDA195 device ground connection. The SN65HVDA195 can operate with a ground shift as long as the ground shift does not reduce V_{SUP} below the minimum operating voltage. If there is a loss of ground at the ECU level, the SN65HVDA195 does not have a significant current consumption on LIN bus.

9.3.6 Enable Input (EN)

EN controls the operation mode of the SN65HVDA195 (normal or sleep mode). When EN is high, the SN65HVDA195 is in normal mode allowing a transmission path from TXD to LIN and from LIN to RXD. When EN is low, the device is put into sleep mode and there are no transmission paths available. The device can enter normal mode only after being woken up. EN has an internal pulldown resistor to make sure the device remains in low-power mode even if EN floats.

9.3.7 NWake Input (NWake)

NWake is a high-voltage input used to wake up the SN65HVDA195 from low-power mode. NWake is usually connected to an external switch in the application. A low on NWake that is asserted longer than the filter time (t_{NWAKE}) results in a local wakeup. NWake provides an internal pullup source to V_{SUP} .

9.3.8 Inhibit Output (INH)

INH is used to control an external voltage regulator that has an inhibit input. When the SN65HVDA195 is in normal operating mode, the inhibit high-side switch is enabled and the external voltage regulator is activated. When SN65HVDA195 is in low-power mode, the inhibit switch is turned off, which disables the voltage regulator. A wake-up event on for the SN65HVDA195 returns INH to V_{SUP} level. INH can also drive an external transistor connected to an MCU interrupt input.

9.4 Device Functional Modes

9.4.1 Operating Modes

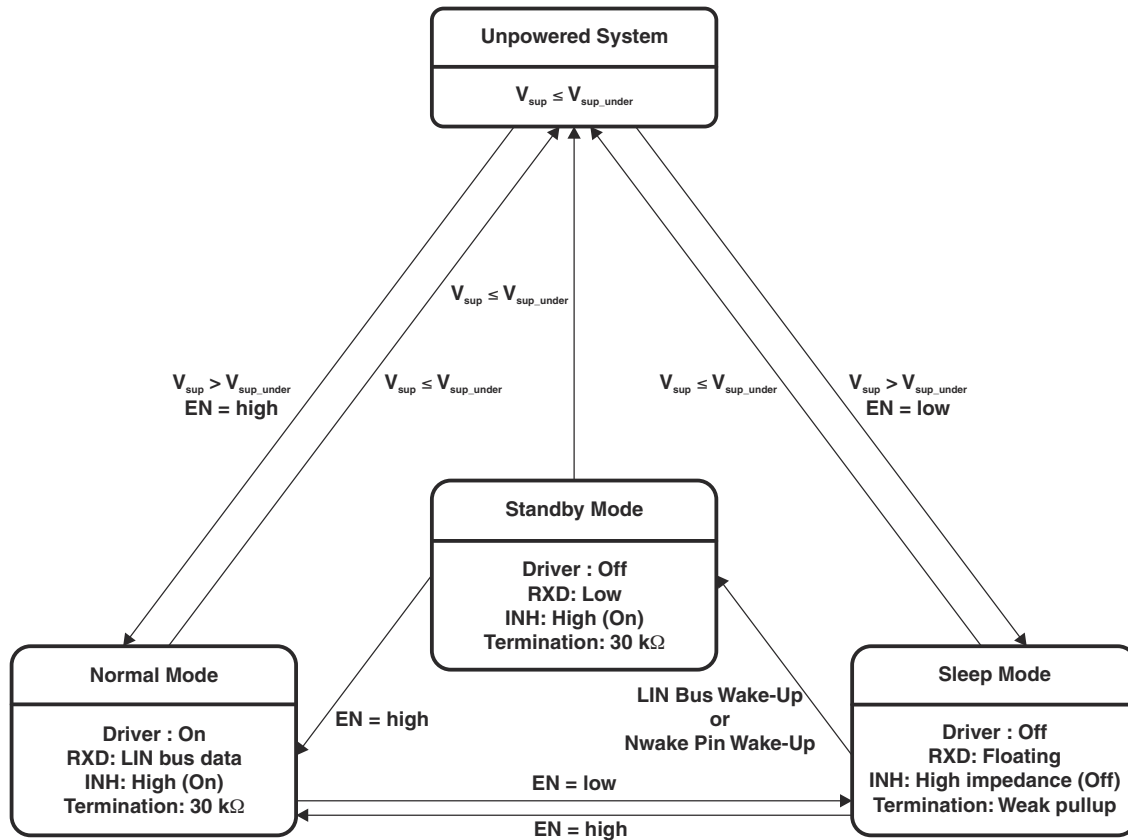

Figure 9-1. Operating States Diagram

Table 9-1. Operating Modes

MODE	EN	RXD	LIN BUS TERMINATION	INH	TRANSMITTER	COMMENTS
Sleep	Low	Floating	Weak current pullup	High impedance	Off	
Standby	Low	Low	30 kΩ (typ)	High	Off	Wake-up event detected, waiting on MCU to set EN
Normal	High	LIN bus data	30 kΩ (typ)	High	On	LIN transmission up to 20 kbps

9.4.2 Normal Mode

This is the normal operational mode, in which the receiver and driver are active, and LIN transmission up to the LIN specified maximum of 20 kbps is supported. The receiver detects the data stream on the LIN bus and outputs it on RXD for the LIN controller, where recessive on the LIN bus is a digital high, and dominate on the LIN bus is digital low. The driver transmits input data on TXD to the LIN bus. Normal mode is entered as EN transitions high while the SN65HVDA195 is in sleep or standby mode.

9.4.3 Sleep Mode

Sleep mode is the power saving mode for the SN65HVDA195 and the default state after power up (assuming EN is low during power up). Even with the extremely low current consumption in this mode, the SN65HVDA195 can still wake up from LIN bus through a wake-up signal, a low on NWake, or if EN is set high. The LIN bus and NWake are filtered to prevent false wake-up events. The wake-up events must be active for their respective time periods (t_{LINBUS} , t_{NWake}).

The sleep mode is entered by setting EN low.

While the device is in sleep mode, the following conditions exist:

- The LIN bus driver is disabled and the internal LIN bus termination is switched off (to minimize power loss if LIN is short-circuited to ground). However, the weak current pullup is active to prevent false wake-up events in case an external connection to the LIN bus is lost.
- The normal receiver is disabled.
- INH is high impedance.
- EN input, NWake input, and the LIN wake-up receiver are active.

9.4.4 Wake-Up Events

There are three ways to wake up the SN65HVDA195 from sleep mode:

- Remote wakeup through recessive (high) to dominant (low) state transition on LIN bus. The dominant state must be held for t_{LINBUS} filter time and then the bus must return to the recessive state (to eliminate false wake-ups from disturbances on the LIN bus or if the bus is shorted to ground).
- Local wakeup through a low on NWake, which is asserted low longer than the filter time t_{NWake} (to eliminate false wake-ups from disturbances on NWake)
- Local wakeup through EN being set high

9.4.5 Standby Mode

This mode is entered whenever a wake-up event occurs through LIN bus or NWake while the SN65HVDA195 is in sleep mode. The LIN bus responder termination circuit and INH are turned on when standby mode is entered. The application system powers up once INH is turned on, assuming the system is using a voltage regulator connected through INH. Standby mode is signaled through a low level on RXD.

When EN is set high while the SN65HVDA195 is in standby mode the device returns to normal mode and the normal transmission paths from TXD to LIN bus and LIN bus to RXD are enabled.

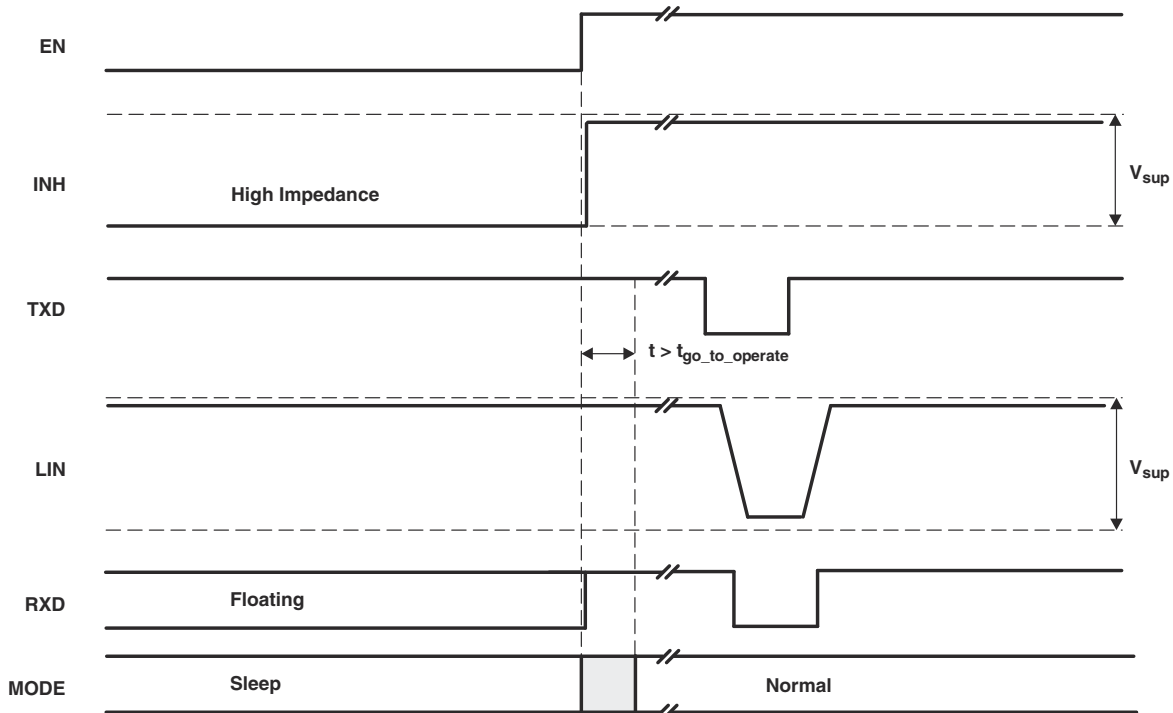

Figure 9-2. Wakeup Through EN

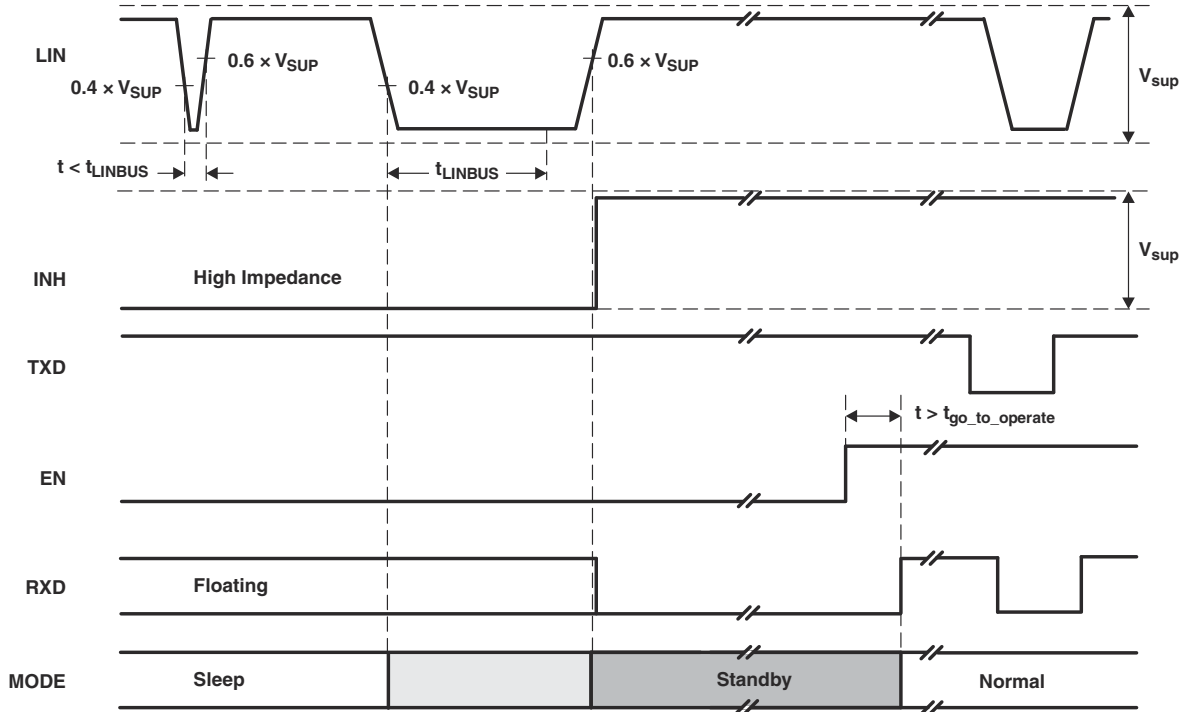

Figure 9-3. Wakeup Through LIN

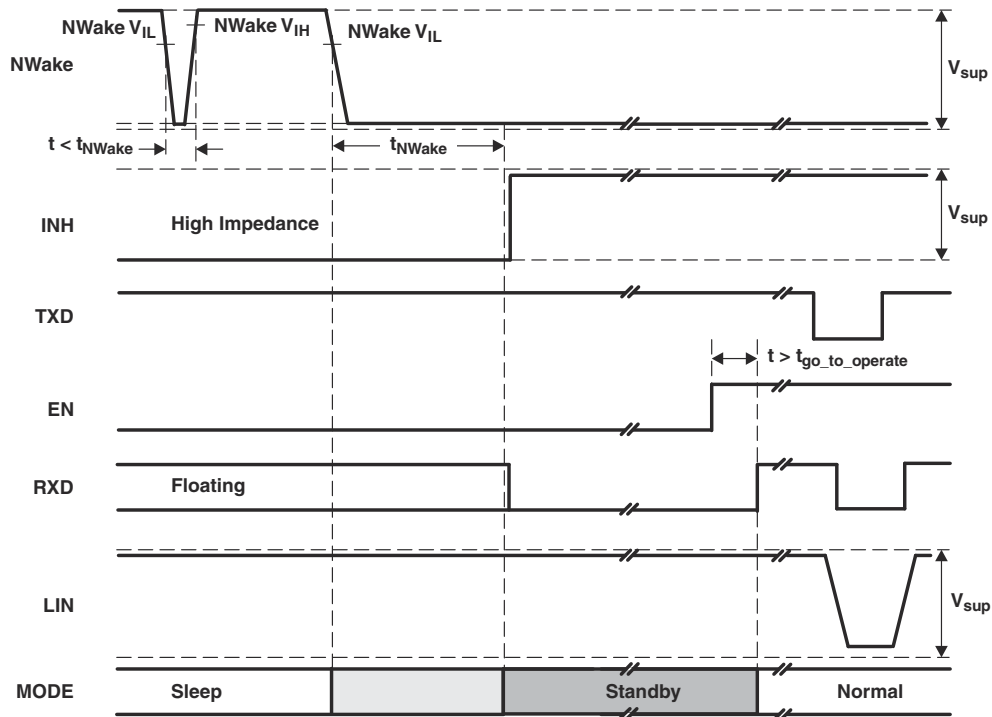

Figure 9-4. Wakeup Through Nwake

10 Application and Implementation

Note

Information in the following applications sections is not part of the TI component specification, and TI does not warrant its accuracy or completeness. TI's customers are responsible for determining suitability of components for their purposes. Customers should validate and test their design implementation to confirm system functionality.

10.1 Application Information

The SN65HVDA195-Q1 can be used as both a responder device and a commander device in a LIN network. It comes with the ability to support both remote wake-up requests and local wake-up requests.

10.1.1 Typical Application

The device comes with an integrated 30-k Ω pullup resistor and series diode for responder applications, and for commander applications an external 1-k Ω pullup with series blocking diode can be used. Figure 10-1 shows the device being used in both types of applications.

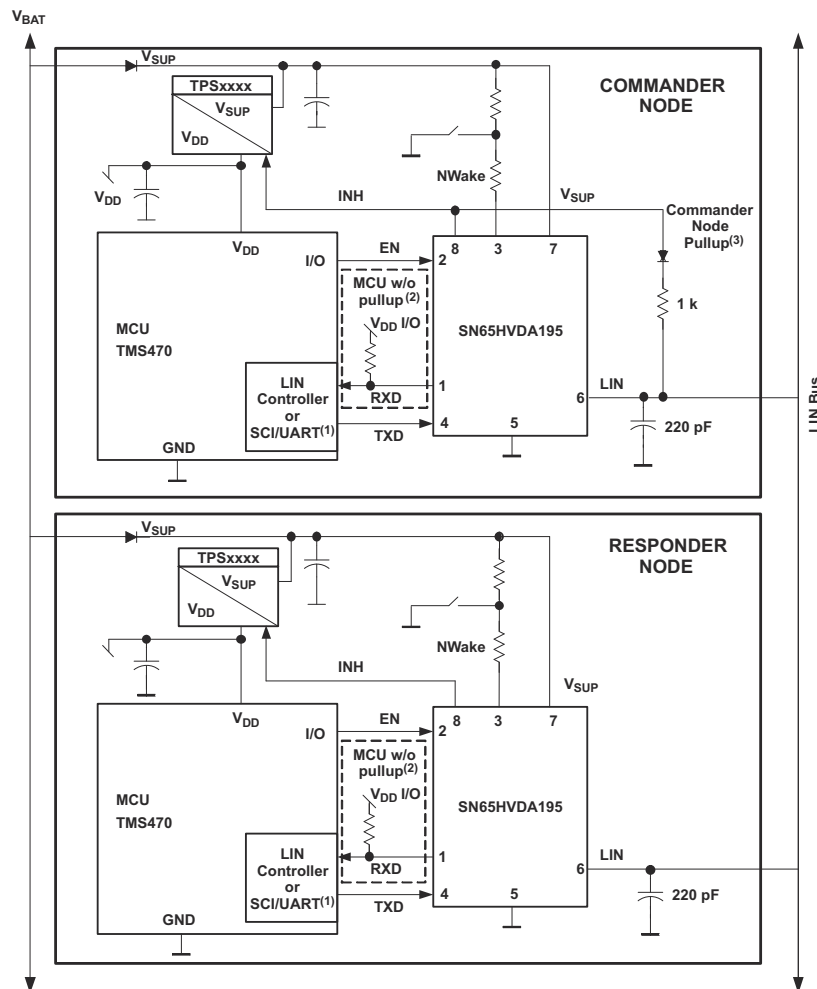

- RXD on MCU or LIN responder has internal pullup, no external pullup resistor is needed.
- RXD on MCU or LIN responder without internal pullup, requires external pullup resistor.
- Commander node applications require an external 1-k Ω pullup resistor and serial diode.

Figure 10-1. SN65HVDA195-Q1 Application Diagram

10.1.1.1 Design Requirements

For this design, use these requirements:

- RXD on MCU or LIN responder has internal pullup, no external pullup resistor is needed.
- RXD on MCU or LIN responder without internal pullup, requires external pullup resistor.
- Commander node applications require an external 1-k Ω pullup resistor and serial diode

10.1.1.2 Detailed Design Procedure

The RXD output structure is an open-drain output stage. This allows the SN65HVDA195-Q1 to be used with 3.3-V and 5-V I/O microcontrollers. If the RXD pin of the microcontroller does not have an integrated pullup, an external pullup resistor to the microcontroller I/O supply voltage is required.

The V_{SUP} pin of the device should be decoupled with a 100-nF capacitor as close to the supply pin of the device as possible.

The NWAKE pin is a high voltage wake-up input to the device. If this pin is not being used it should be tied to V_{SUP}.

10.1.1.3 Application Curves

Figure 10-2 and Figure 10-3 show the propagation delay from the TXD pin to the LIN pin for both the recessive to dominant and dominant to recessive states under lightly loaded conditions.

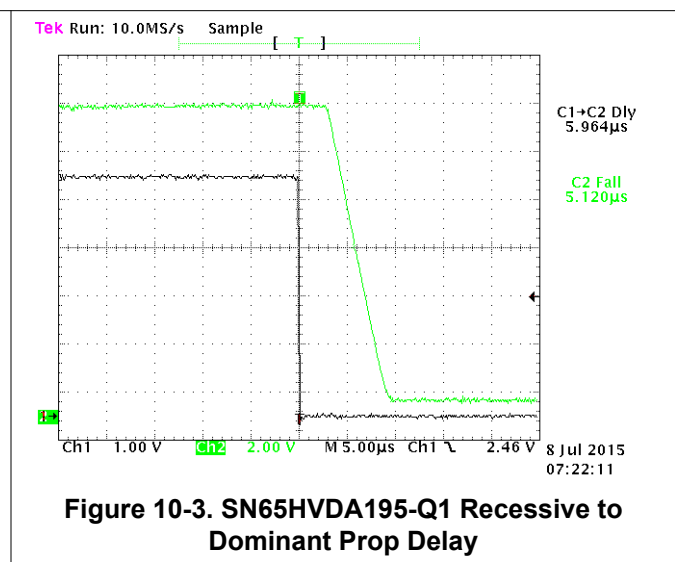
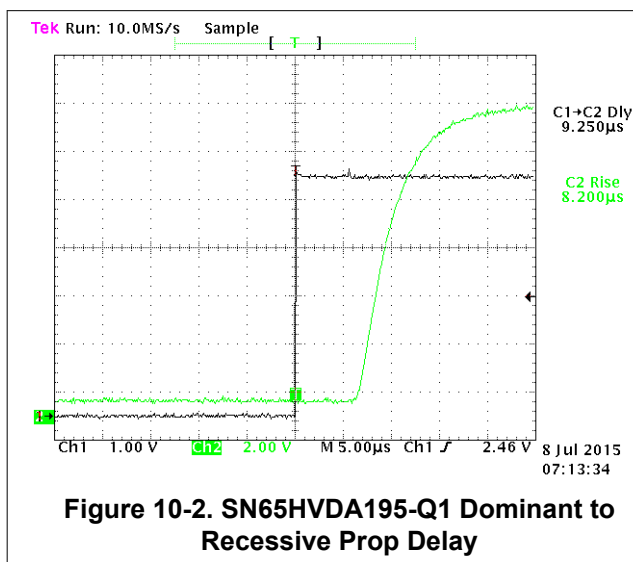

Power Supply Recommendations

The SN65HVDSA195-Q1 was designed to operate directly off a car battery, or any other DC supply ranging from 7 V to 27 V. A 100-nF decoupling capacitor should be placed as close to the V_{SUP} pin of the device as possible.

10.1.2 Layout

10.1.2.1 Layout Guidelines

Pin 1 is the RXD output of the SN65HVDA195-Q1. It is an open-drain output and requires an external pullup resistor in the range of 1-k Ω to 10 k Ω to function properly. If the micro-processor paired with the transceiver does not have an integrated pullup and external resistor should be placed between RXD and the regulated voltage supply for the micro-processor.

Pin 2 is the EN input pin for the device that is used to place the device in low power sleep mode. If this feature is not used on the device, the pin should be pulled high to the regulated voltage supply of the microprocessor through a series 1-k Ω to 10-k Ω series resistor. Additionally, a series resistor may be placed on the pin to limit the current on the digital lines in the case of an overvoltage fault.

Pin 3 is a high-voltage local wake up input pin. The device is typically externally controlled by a normally open switch tied between NWAKE and ground. When the momentary switch is pressed the NWAKE pin is pulled to ground signaling a local wake-up event. A series resistor between V_{BATT} and the switch, and NWAKE and the switch should be placed to limit current. If the NWAKE local wake-up feature is not used, the pin can be tied to V_{SUP} through a 1-k Ω to 10-k Ω pullup resistor.

Pin 4 is the transmit input signal to the device. A series resistor can be placed to limit the input current to the device in the case of an overvoltage on this pin. Also a capacitor to ground can be placed close to the input pin of the device to filter noise.

Pin 5 is the ground connection of the device. This pin should be tied to a ground plane through a short trace with the use of two vias to limit total return inductance.

Pin 6 is the LIN bus connection of the device. For responder applications a 220-pF bus capacitor is implemented. For commander applications an additional series resistor and blocking diode should be placed between the LIN pin and the V_{SUP} pin.

Pin 7 is the supply pin for the device. A 100-nF decoupling capacitor should be placed as close to the device as possible.

Pin 8 is a high-voltage output pin that may be used to control the local power supplies. If this feature is not used the pin may be left floating.

Note

All ground and power connections should be made as short as possible and use at least two vias to minimize the total loop inductance.

10.1.2.2 Layout Example

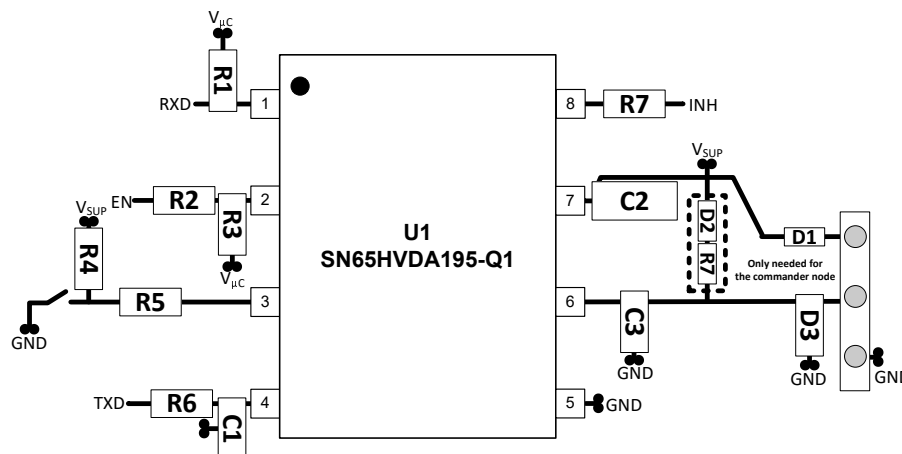

Figure 10-4. Layout Example

11 Device and Documentation Support

11.1 Receiving Notification of Documentation Updates

To receive notification of documentation updates, navigate to the device product folder on ti.com. Click on *Subscribe to updates* to register and receive a weekly digest of any product information that has changed. For change details, review the revision history included in any revised document.

11.2 Support Resources

TI E2E™ [support forums](#) are an engineer's go-to source for fast, verified answers and design help — straight from the experts. Search existing answers or ask your own question to get the quick design help you need.

Linked content is provided "AS IS" by the respective contributors. They do not constitute TI specifications and do not necessarily reflect TI's views; see TI's [Terms of Use](#).

11.3 Trademarks

TI E2E™ is a trademark of Texas Instruments.

All trademarks are the property of their respective owners.

11.4 Electrostatic Discharge Caution



This integrated circuit can be damaged by ESD. Texas Instruments recommends that all integrated circuits be handled with appropriate precautions. Failure to observe proper handling and installation procedures can cause damage.

ESD damage can range from subtle performance degradation to complete device failure. Precision integrated circuits may be more susceptible to damage because very small parametric changes could cause the device not to meet its published specifications.

11.5 Glossary

[TI Glossary](#) This glossary lists and explains terms, acronyms, and definitions.

12 Mechanical, Packaging, and Orderable Information

The following pages include mechanical, packaging, and orderable information. This information is the most current data available for the designated devices. This data is subject to change without notice and revision of this document. For browser-based versions of this data sheet, refer to the left-hand navigation.

PACKAGING INFORMATION

Orderable Device	Status (1)	Package Type	Package Drawing	Pins	Package Qty	Eco Plan (2)	Lead finish/ Ball material (6)	MSL Peak Temp (3)	Op Temp (°C)	Device Marking (4/5)	Samples
SN65HVDA195QDRQ1	ACTIVE	SOIC	D	8	2500	RoHS & Green	NIPDAU	Level-1-260C-UNLIM	-40 to 125	A195Q	Samples

(1) The marketing status values are defined as follows:

ACTIVE: Product device recommended for new designs.

LIFEBUY: TI has announced that the device will be discontinued, and a lifetime-buy period is in effect.

NRND: Not recommended for new designs. Device is in production to support existing customers, but TI does not recommend using this part in a new design.

PREVIEW: Device has been announced but is not in production. Samples may or may not be available.

OBSOLETE: TI has discontinued the production of the device.

(2) **RoHS:** TI defines "RoHS" to mean semiconductor products that are compliant with the current EU RoHS requirements for all 10 RoHS substances, including the requirement that RoHS substance do not exceed 0.1% by weight in homogeneous materials. Where designed to be soldered at high temperatures, "RoHS" products are suitable for use in specified lead-free processes. TI may reference these types of products as "Pb-Free".

RoHS Exempt: TI defines "RoHS Exempt" to mean products that contain lead but are compliant with EU RoHS pursuant to a specific EU RoHS exemption.

Green: TI defines "Green" to mean the content of Chlorine (Cl) and Bromine (Br) based flame retardants meet JS709B low halogen requirements of <=1000ppm threshold. Antimony trioxide based flame retardants must also meet the <=1000ppm threshold requirement.

(3) MSL, Peak Temp. - The Moisture Sensitivity Level rating according to the JEDEC industry standard classifications, and peak solder temperature.

(4) There may be additional marking, which relates to the logo, the lot trace code information, or the environmental category on the device.

(5) Multiple Device Markings will be inside parentheses. Only one Device Marking contained in parentheses and separated by a "-" will appear on a device. If a line is indented then it is a continuation of the previous line and the two combined represent the entire Device Marking for that device.

(6) Lead finish/Ball material - Orderable Devices may have multiple material finish options. Finish options are separated by a vertical ruled line. Lead finish/Ball material values may wrap to two lines if the finish value exceeds the maximum column width.

Important Information and Disclaimer:The information provided on this page represents TI's knowledge and belief as of the date that it is provided. TI bases its knowledge and belief on information provided by third parties, and makes no representation or warranty as to the accuracy of such information. Efforts are underway to better integrate information from third parties. TI has taken and continues to take reasonable steps to provide representative and accurate information but may not have conducted destructive testing or chemical analysis on incoming materials and chemicals. TI and TI suppliers consider certain information to be proprietary, and thus CAS numbers and other limited information may not be available for release.

In no event shall TI's liability arising out of such information exceed the total purchase price of the TI part(s) at issue in this document sold by TI to Customer on an annual basis.

TAPE AND REEL INFORMATION

QUADRANT ASSIGNMENTS FOR PIN 1 ORIENTATION IN TAPE

*All dimensions are nominal

Device	Package Type	Package Drawing	Pins	SPQ	Reel Diameter (mm)	Reel Width W1 (mm)	A0 (mm)	B0 (mm)	K0 (mm)	P1 (mm)	W (mm)	Pin1 Quadrant
SN65HVDA195QDRQ1	SOIC	D	8	2500	330.0	12.4	6.4	5.2	2.1	8.0	12.0	Q1

TAPE AND REEL BOX DIMENSIONS

*All dimensions are nominal

Device	Package Type	Package Drawing	Pins	SPQ	Length (mm)	Width (mm)	Height (mm)
SN65HVDA195QDRQ1	SOIC	D	8	2500	356.0	356.0	35.0



D0008A

PACKAGE OUTLINE

SOIC - 1.75 mm max height

SMALL OUTLINE INTEGRATED CIRCUIT



NOTES:

1. Linear dimensions are in inches [millimeters]. Dimensions in parenthesis are for reference only. Controlling dimensions are in inches. Dimensioning and tolerancing per ASME Y14.5M.
2. This drawing is subject to change without notice.
3. This dimension does not include mold flash, protrusions, or gate burrs. Mold flash, protrusions, or gate burrs shall not exceed $.006$ [0.15] per side.
4. This dimension does not include interlead flash.
5. Reference JEDEC registration MS-012, variation AA.

EXAMPLE STENCIL DESIGN

D0008A

SOIC - 1.75 mm max height

SMALL OUTLINE INTEGRATED CIRCUIT



SOLDER PASTE EXAMPLE
BASED ON .005 INCH [0.125 MM] THICK STENCIL
SCALE:8X

4214825/C 02/2019

NOTES: (continued)

8. Laser cutting apertures with trapezoidal walls and rounded corners may offer better paste release. IPC-7525 may have alternate design recommendations.
9. Board assembly site may have different recommendations for stencil design.

IMPORTANT NOTICE AND DISCLAIMER

TI PROVIDES TECHNICAL AND RELIABILITY DATA (INCLUDING DATA SHEETS), DESIGN RESOURCES (INCLUDING REFERENCE DESIGNS), APPLICATION OR OTHER DESIGN ADVICE, WEB TOOLS, SAFETY INFORMATION, AND OTHER RESOURCES "AS IS" AND WITH ALL FAULTS, AND DISCLAIMS ALL WARRANTIES, EXPRESS AND IMPLIED, INCLUDING WITHOUT LIMITATION ANY IMPLIED WARRANTIES OF MERCHANTABILITY, FITNESS FOR A PARTICULAR PURPOSE OR NON-INFRINGEMENT OF THIRD PARTY INTELLECTUAL PROPERTY RIGHTS.

These resources are intended for skilled developers designing with TI products. You are solely responsible for (1) selecting the appropriate TI products for your application, (2) designing, validating and testing your application, and (3) ensuring your application meets applicable standards, and any other safety, security, regulatory or other requirements.

These resources are subject to change without notice. TI grants you permission to use these resources only for development of an application that uses the TI products described in the resource. Other reproduction and display of these resources is prohibited. No license is granted to any other TI intellectual property right or to any third party intellectual property right. TI disclaims responsibility for, and you will fully indemnify TI and its representatives against, any claims, damages, costs, losses, and liabilities arising out of your use of these resources.

TI's products are provided subject to [TI's Terms of Sale](#) or other applicable terms available either on [ti.com](#) or provided in conjunction with such TI products. TI's provision of these resources does not expand or otherwise alter TI's applicable warranties or warranty disclaimers for TI products.

TI objects to and rejects any additional or different terms you may have proposed.

Mailing Address: Texas Instruments, Post Office Box 655303, Dallas, Texas 75265
Copyright © 2022, Texas Instruments Incorporated

Looking for pricing, stock, or lifecycle information?

Click below to explore more details on WIN SOURCE:

 [View SN65HVDA195QDRQ1 on WIN SOURCE](#)

 [Texas Instruments](#) Information

Optimize Your Supply Chain with WIN SOURCE Solutions

-  Global Sourcing Solution
-  Obsolete Management
-  Cost Control Management
-  Shortage Management
-  Alternative Solution
-  Excess Inventory Management