



**THE DATASHEET OF
ADN2915ACPZ**



TABLE OF CONTENTS

| | | | |
|--|----|---|----|
| Features | 1 | Frequency Acquisition..... | 22 |
| Applications..... | 1 | Limiting Amplifier | 22 |
| General Description | 1 | Slice Adjust..... | 22 |
| Functional Block Diagram | 1 | Edge Select..... | 22 |
| Revision History | 2 | Loss of Signal (LOS) Detector | 23 |
| Specifications..... | 3 | Passive Equalizer | 24 |
| Jitter Specifications..... | 5 | Bypass..... | 24 |
| Output and Timing Specifications | 6 | Lock Detector Operation | 25 |
| Timing Diagrams..... | 8 | Harmonic Detector | 25 |
| Absolute Maximum Ratings..... | 9 | Output Disable and Squelch | 26 |
| Thermal Characteristics | 9 | I ² C Interface | 26 |
| ESD Caution..... | 9 | Reference Clock (Optional) | 26 |
| Pin Configuration and Function Descriptions..... | 10 | Additional Features Available via the I ² C Interface..... | 28 |
| Typical Performance Characteristics | 11 | Input Configurations | 30 |
| I ² C Interface Timing and Internal Register Descriptions | 14 | DC-Coupled Application | 32 |
| Register Map | 15 | Outline Dimensions | 33 |
| Theory of Operation | 20 | Ordering Guide | 33 |
| Functional Description | 22 | | |

REVISION HISTORY

1/16—Rev. 0 to Rev. A

| | |
|----------------------------------|------------|
| Changed NC to DNC | Throughout |
| Changes to Figure 5..... | 10 |
| Updated Outline Dimensions | 33 |
| Changes to Ordering Guide | 33 |

7/13—Revision 0: Initial Version

SPECIFICATIONS

$T_A = T_{MIN}$ to T_{MAX} , $V_{CC} = V_{CC_{MIN}}$ to $V_{CC_{MAX}}$, $V_{CC1} = V_{CC1_{MIN}}$ to $V_{CC1_{MAX}}$, $V_{DD} = V_{DD_{MIN}}$ to $V_{DD_{MAX}}$, $V_{EE} = 0$ V, input data pattern: PRBS $2^{23} - 1$, ac-coupled, I²C register default settings, unless otherwise noted.

Table 1.

| Parameter | Test Conditions/Comments | Min | Typ | Max | Unit |
|--|---|--------|------|------------|--------|
| DATA RATE SUPPORT RANGE | | 0.0065 | | 11.3 | Gbps |
| INPUT—DC CHARACTERISTICS | | | | | |
| Peak-to-Peak Differential Input ¹ | PIN – NIN | | | 1.0 | V |
| Input Resistance | Differential | 95 | 100 | 105 | Ω |
| BYPASS PATH—CML INPUT | | | | | |
| Input Voltage Range | At PIN or NIN, dc-coupled, RX_TERM_FLOAT = 1 (float) | 0.5 | | VCC | V |
| Input Common-Mode Level | DC-coupled (see Figure 39), 600 mV p-p differential, RX_TERM_FLOAT = 1 (float) | 0.65 | | VCC – 0.15 | V |
| Differential Input Sensitivity | | | | | |
| OC-192 | AC-coupled, RX_TERM_FLOAT = 0 ($V_{CM} = 1.2$ V), bit error rate (BER) = 1×10^{-10} | | 200 | | mV p-p |
| 8GFC ² | Jitter tolerance scrambled pattern (JTSPAT), ac-coupled, RX_TERM_FLOAT = 0 ($V_{CM} = 1.2$ V), BER = 1×10^{-12} | | 200 | | mV p-p |
| LIMITING AMPLIFIER INPUT PATH | | | | | |
| Differential Input Sensitivity | | | | | |
| OC-48 | BER = 1×10^{-10} | | 7.0 | | mV p-p |
| OC-192 | BER = 1×10^{-10} | | 9.2 | | mV p-p |
| 8GFC ² | JTSPAT, BER = 1×10^{-12} | | 8.3 | | mV p-p |
| 10.3125 Gbps | JTSPAT, BER = 1×10^{-12} | | 11.0 | | mV p-p |
| EQUALIZER INPUT PATH | | | | | |
| Differential Input Sensitivity | 15 inch FR-4, 100 Ω differential transmission line, adaptive EQ on | | | | |
| 8GFC ² | JTSPAT, BER = 1×10^{-12} | | 115 | | mV p-p |
| OC-192 | BER = 1×10^{-10} | | 184 | | mV p-p |
| INPUT—AC CHARACTERISTICS | | | | | |
| S11 | At 7.5 GHz, differential return loss, see Figure 14 | | –12 | | dB |
| LOSS OF SIGNAL DETECT (LOS) | | | | | |
| Loss of Signal Detect | | | 10 | | mV p-p |
| | Loss of signal minimum program value | | 5 | | mV p-p |
| | Loss of signal maximum program value | | 128 | | mV p-p |
| Hysteresis (Electrical) | | | 5.7 | | dB |
| LOS Assert Time | AC-coupled ³ | | 135 | | μs |
| LOS Deassert Time | AC-coupled ³ | | 110 | | μs |
| LOSS OF LOCK (LOL) DETECT | | | | | |
| DCO Frequency Error for LOL Assert | With respect to nominal, data collected in lock to reference (LTR) mode | | 1000 | | ppm |
| DCO Frequency Error for LOL Deassert | With respect to nominal, data collected in LTR mode | | 250 | | ppm |
| LOL Assert Response Time | 10.0 Mbps | | 10 | | ms |
| | 2.5 Gbps | | 51 | | μs |
| | 8.5 Gbps, JTSPAT | | 25 | | μs |
| | 10 Gbps | | 18 | | μs |
| ACQUISITION TIME | | | | | |
| Lock to Data (LTD) Mode | 10 Mbps | | 24 | | ms |
| | 2.5 Gbps | | 0.5 | | ms |
| | 8.5 Gbps, JTSPAT | | 0.5 | | ms |
| | 10 Gbps | | 0.5 | | ms |
| Optional LTR Mode ⁴ | | | 6.0 | | ms |

| Parameter | Test Conditions/Comments | Min | Typ | Max | Unit |
|-----------------------------|---|------|-------|-------|------|
| DATA RATE READBACK ACCURACY | | | | | |
| Coarse Readback | | | ±5 | | % |
| Fine Readback | In addition to reference clock accuracy | | ±100 | | ppm |
| POWER SUPPLY VOLTAGE | | | | | |
| VCC | | 1.14 | 1.2 | 1.26 | V |
| VDD | | 2.97 | 3.3 | 3.63 | V |
| VCC1 | | 1.62 | 1.8 | 3.63 | V |
| POWER SUPPLY CURRENT | Limiting amplifier mode, clock output enabled | | | | |
| VCC | 1.25 Gbps | | 277.1 | 311.0 | mA |
| | 3.125 Gbps | | 256.2 | 288.3 | mA |
| | 4.25 Gbps | | 270.1 | 304.0 | mA |
| | 6.144 Gbps | | 303.1 | 340.4 | mA |
| | 8GFC, ² JTSPAT | | 319.1 | 359.5 | mA |
| | OC-192 | | 333 | 377.4 | mA |
| VDD | 1.25 Gbps | | 7.24 | 8.28 | mA |
| | 3.125 Gbps | | 7.21 | 8.21 | mA |
| | 4.25 Gbps | | 7.23 | 8.33 | mA |
| | 6.144 Gbps | | 7.26 | 8.17 | mA |
| | 8GFC, ² JTSPAT | | 7.20 | 8.1 | mA |
| VCC1 | OC-192 | | 7.21 | 8.59 | mA |
| | 1.25 Gbps | | 35.6 | 46.8 | mA |
| | 3.125 Gbps | | 19.0 | 24.1 | mA |
| | 4.25 Gbps | | 22.2 | 28.2 | mA |
| | 6.144 Gbps | | 19.4 | 24.6 | mA |
| | 8GFC, ² JTSPAT | | 22.2 | 28.4 | mA |
| | OC-192 | | 35.1 | 47.4 | mA |
| TOTAL POWER DISSIPATION | Limiting amplifier mode, clock output enabled | | | | |
| | 1.25 Gbps | | 420.4 | | mW |
| | 3.125 Gbps | | 365.5 | | mW |
| | 4.25 Gbps | | 388 | | mW |
| | 6.144 Gbps | | 422.5 | | mW |
| | 8GFC, ² JTSPAT | | 446.6 | | mW |
| | OC-192 | | 486.5 | | mW |
| OPERATING TEMPERATURE RANGE | | -40 | | +85 | °C |

¹ See Figure 40.

² Fibre Channel Physical Interface 4 standard, FC-P1-4, Rev 8.00, May 21, 2008.

³ When ac-coupled, the LOS assert and deassert times are dominated by the RC time constant of the ac coupling capacitor and the 100 Ω differential input termination of the ADN2915 input stage.

⁴ This typical acquisition specification applies to all selectable reference clock frequencies in the range of 11.05 MHz to 176.8 MHz.

JITTER SPECIFICATIONS

$T_A = T_{MIN}$ to T_{MAX} , $VCC = VCC_{MIN}$ to VCC_{MAX} , $VCC1 = VCC1_{MIN}$ to $VCC1_{MAX}$, $VDD = VDD_{MIN}$ to VDD_{MAX} , $VEE = 0$ V, input data pattern: PRBS $2^{23} - 1$, ac-coupled to 100 Ω differential termination load, I²C register default settings, unless otherwise noted.

Table 2.

| Parameter | Test Conditions/Comments | Min | Typ | Max | Unit |
|---|---|------------|-------------|--------|--------|
| PHASE-LOCKED LOOP CHARACTERISTICS | | | | | |
| Jitter Transfer Bandwidth (BW) ¹ | | | | | |
| OC-192 | TRANBW[2:0] = 3 | | 1064 | 1650 | kHz |
| | OTN mode, ² TRANBW[2:0] = 1 | | 294 | 529 | kHz |
| 8GFC ³ | | | 1242 | 1676 | kHz |
| OC-48 | TRANBW[2:0] = 4 (default) | | 663 | 896 | kHz |
| | OTN mode, ² TRANBW[2:0] = 1 | | 157 | 181 | kHz |
| OC-12 | | | 175 | | kHz |
| OC-3 | | | 44 | | kHz |
| Jitter Peaking | | | | | |
| OC-192 | 20 kHz to 80 MHz | | 0.014 | 0.024 | dB |
| 8GFC ³ | 20 kHz to 80 MHz | | 0.004 | 0.021 | dB |
| OC-48 | 20 kHz to 10 MHz | | 0.004 | 0.023 | dB |
| OC-12 | | | 0.01 | | dB |
| OC-3 | | | 0.01 | | dB |
| Jitter Generation | | | | | |
| OC-192 | Unfiltered | | 0.0045 | 0.0067 | UI rms |
| | Unfiltered | | 0.076 | | UI p-p |
| 8GFC ³ | Unfiltered | | 0.005 | | UI rms |
| | Unfiltered | | 0.044 | | UI p-p |
| OC-48 | 12 kHz to 20 MHz | | 0.0025 | | UI rms |
| | Unfiltered | | | 0.0046 | UI rms |
| | 12 kHz to 20 MHz | | 0.0156 | | UI p-p |
| | Unfiltered | | | 0.0276 | UI p-p |
| OC-12 | 12 kHz to 5 MHz | | 0.0007 | | UI rms |
| | Unfiltered | | | 0.0011 | UI rms |
| | 12 kHz to 5 MHz | | 0.0038 | | UI p-p |
| | Unfiltered | | | 0.0076 | UI p-p |
| OC-3 | 12 kHz to 1.3 MHz | | 0.0002 | | UI rms |
| | Unfiltered | | | 0.0003 | UI rms |
| | 12 kHz to 1.3 MHz | | 0.0008 | | UI p-p |
| | Unfiltered | | | 0.0018 | UI p-p |
| Jitter Tolerance | TRANBW[2:0] = 4 (default) | | | | |
| OC-192 | 2000 Hz | | 4255 | | UI p-p |
| | 20 kHz | | 106 | | UI p-p |
| | 400 kHz | | 3.78 | | UI p-p |
| | 4 MHz | | 0.46 | | UI p-p |
| | 80 MHz | | 0.42 | | UI p-p |
| 8GFC, ³ JTSPAT | | | | | |
| Sinusoidal Jitter at 340 kHz | | | 6.7 | | UI p-p |
| Sinusoidal Jitter at 5.098 MHz | | | 0.53 | | UI p-p |
| Sinusoidal Jitter at 80 MHz | | | 0.59 | | UI p-p |
| Rx Jitter Tracking Test ⁴ | Voltage modulation amplitude (VMA) = 170 mV p-p at 100 MHz, 425 mV p-p at 100 MHz, 170 mV p-p at 2.5 GHz, and 425 mV p-p at 2.5 GHz excitation frequency ⁵ | | | | |
| 510 kHz, 1 UI | | 10^{-12} | $<10^{-12}$ | | BER |
| 100 kHz, 5 UI | | 10^{-12} | $<10^{-12}$ | | BER |

| Parameter | Test Conditions/Comments | Min | Typ | Max | Unit |
|-----------|--------------------------|-----|------|-----|--------|
| OC-48 | 600 Hz | | 1528 | | UI p-p |
| | 6 kHz | | 378 | | UI p-p |
| | 100 kHz | | 16.6 | | UI p-p |
| | 1 MHz | | 0.70 | | UI p-p |
| | 20 MHz | | 0.63 | | UI p-p |
| OC-12 | 30 Hz | | 193 | | UI p-p |
| | 300 Hz | | 44 | | UI p-p |
| | 25 kHz | | 19.2 | | UI p-p |
| | 250 kHz | | 0.82 | | UI p-p |
| | 5 MHz | | 0.60 | | UI p-p |
| OC-3 | 30 Hz | | 50.0 | | UI p-p |
| | 300 Hz | | 24.0 | | UI p-p |
| | 6500 Hz | | 14.4 | | UI p-p |
| | 65 kHz | | 0.80 | | UI p-p |
| | 1.3 MHz | | 0.61 | | UI p-p |

¹ Jitter transfer bandwidth is programmable by adjusting TRANBW[2:0] in the DPLLA register (0x10).

² Set TRANBW[2:0] = 1 to enter OTN mode. OTN is the optical transport network as defined in ITU G.709.

³ Fibre Channel Physical Interface 4 standard, FC-P1-4, Rev 8.00, May 21, 2008.

⁴ Conditions of FC-P1-4, Rev 8.00, Table 27, 800-DF-EL-S apply.

⁵ Must have zero errors during the tests for an interval of time that is $\leq 10^{-12}$ BER to pass the tests.

OUTPUT AND TIMING SPECIFICATIONS

$T_A = T_{MIN}$ to T_{MAX} , $V_{CC} = V_{CC_{MIN}}$ to $V_{CC_{MAX}}$, $V_{CC1} = V_{CC1_{MIN}}$ to $V_{CC1_{MAX}}$, $V_{DD} = V_{DD_{MIN}}$ to $V_{DD_{MAX}}$, $V_{EE} = 0$ V, input data pattern: PRBS $2^{23} - 1$, ac-coupled to 100 Ω differential termination load, I²C register default settings, unless otherwise noted.

Table 3.

| Parameter | Test Conditions/Comments | Min | Typ | Max | Unit |
|--|---|------------|-------------|------------|--------|
| CML OUTPUT CHARACTERISTICS | | | | | |
| Data Differential Output Swing | OC-192, DATA_SWING[3:0] setting = 0xC (default) | 535 | 600 | 672 | mV p-p |
| | OC-192, DATA_SWING[3:0] setting = 0xF (maximum) | 668 | 724 | 771 | mV p-p |
| | OC-192, DATA_SWING[3:0] setting = 0x4 (minimum) | 189 | 219 | 252 | mV p-p |
| Clock Differential Output Swing | OC-192, CLOCK_SWING[3:0] setting = 0xC (default) | 406 | 508 | 570 | mV p-p |
| | OC-192, CLOCK_SWING[3:0] setting = 0xF (maximum) | 448 | 583 | 659 | mV p-p |
| | OC-192, CLOCK_SWING[3:0] setting = 0x4 (minimum) | 162 | 217 | 249 | mV p-p |
| Data Differential Output Swing | 8GFC, DATA_SWING[3:0] setting = 0xC (default) | 540 | 600 | 666 | mV p-p |
| | 8GFC, DATA_SWING[3:0] setting = 0xF (maximum) | 662 | 725 | 778 | mV p-p |
| | 8GFC, DATA_SWING[3:0] setting = 0x4 (minimum) | 190 | 214 | 245 | mV p-p |
| Clock Differential Output Swing | 8GFC, CLOCK_SWING[3:0] setting = 0xC (default) | 426 | 518 | 588 | mV p-p |
| | 8GFC, CLOCK_SWING[3:0] setting = 0xF (maximum) | 489 | 603 | 680 | mV p-p |
| | 8GFC, CLOCK_SWING[3:0] setting = 0x4 (minimum) | 166 | 213 | 245 | mV p-p |
| Output High Voltage | V_{OH} , dc-coupled | VCC – 0.05 | VCC – 0.025 | VCC | V |
| Output Low Voltage | V_{OL} , dc-coupled | VCC – 0.36 | VCC – 0.325 | VCC – 0.29 | V |
| CML OUTPUT TIMING CHARACTERISTICS | | | | | |
| Rise Time | 20% to 80%, at OC-192, DATOUTN/DATOUTP | 17.4 | 32.6 | 46.5 | ps |
| | 20% to 80%, at OC-192, CLKOUTN/CLKOUTP | 22.2 | 28.3 | 33.1 | ps |
| | 20% to 80%, at 8GFC, ¹ DATOUTN/DATOUTP | 20.4 | 33.1 | 44 | ps |
| | 20% to 80%, at 8GFC, ¹ CLKOUTN/CLKOUTP | 23.1 | 29.7 | 35.8 | ps |
| Fall Time | 80% to 20%, at OC-192, DATOUTN/DATOUTP | 17.5 | 33 | 49.1 | ps |
| | 20% to 80%, at OC-192, CLKOUTN/CLKOUTP | 23.9 | 29.2 | 33.7 | ps |
| | 80% to 20%, at 8GFC, ¹ DATOUTN/DATOUTP | 23 | 34.2 | 46.8 | ps |
| | 20% to 80%, at 8GFC, ¹ CLKOUTN/CLKOUTP | 25 | 31.3 | 37.1 | ps |
| Setup Time, Full Rate Clock | t_s (see Figure 2) | | 0.5 | | UI |
| Hold Time, Full Rate Clock | t_h (see Figure 2) | | 0.5 | | UI |
| Setup Time, DDR Clock | t_s (see Figure 3) | | 0.5 | | UI |
| Hold Time, DDR clock | t_h (see Figure 3) | | 0.5 | | UI |

| Parameter | Test Conditions/Comments | Min | Typ | Max | Unit |
|--|--|--------------------------------------|-----|-------|-------------|
| I²C INTERFACE DC CHARACTERISTICS | | | | | |
| | LVTTTL | | | | |
| Input High Voltage | V _{IH} | 2.0 | | | V |
| Input Low Voltage | V _{IL} | | | 0.8 | V |
| Input Current | V _{IN} = 0.1 × VDD or V _{IN} = 0.9 × VDD | -10.0 | | +10.0 | μA |
| Output Low Voltage | V _{OL} , I _{OL} = 3.0 mA | | | 0.4 | V |
| I²C INTERFACE TIMING | | | | | |
| | See Figure 24 | | | | |
| SCK Clock Frequency | | | | 400 | kHz |
| SCK Pulse Width High | t _{HIGH} | 600 | | | ns |
| SCK Pulse Width Low | t _{LOW} | 1300 | | | ns |
| Start Condition Hold Time | t _{HD,STA} | 600 | | | ns |
| Start Condition Setup Time | t _{SU,STA} | 600 | | | ns |
| Data Setup Time | t _{SU,DAT} | 100 | | | ns |
| Data Hold Time | t _{HD,DAT} | 300 | | | ns |
| SCK/SDA Rise/Fall Time | t _R /t _F | 20 + 0.1 C _b ² | | 300 | ns |
| Stop Condition Setup Time | t _{SU,STO} | 600 | | | ns |
| Bus Free Time Between Stop and Start Conditions | t _{BUF} | 1300 | | | ns |
| LVTTTL DC INPUT CHARACTERISTICS (I²C_ADDR) | | | | | |
| Input Voltage | | | | | |
| High | V _{IH} | 2.0 | | | V |
| Low | V _{IL} | | | 0.8 | V |
| Input Current | | | | | |
| High | I _{IH} , V _{IN} = 2.4 V | | | +5 | μA |
| Low | I _{IL} , V _{IN} = 0.4 V | -5 | | | μA |
| LVTTTL DC OUTPUT CHARACTERISTICS (LOS/LOL) | | | | | |
| Output Voltage | | | | | |
| High | V _{OH} , I _{OH} = +2.0 mA | 2.4 | | | V |
| Low | V _{OL} , I _{OL} = -2.0 mA | | | 0.4 | V |
| REFERENCE CLOCK CHARACTERISTICS | | | | | |
| | Optional LTR mode | | | | |
| Input Compliance Voltage (Single-Ended) | V _{CM} (no input offset, no input current), see Figure 32, ac-coupled input | 0.55 | | 1.0 | V |
| Minimum Input Drive | See Figure 32, ac-coupled, differential input | | 100 | | mV p-p diff |
| Reference Frequency | | 11.05 | | 176.8 | MHz |
| Required Accuracy ³ | AC-coupled, differential input | | 100 | | ppm |

¹ Fibre Channel Physical Interface 4 standard, FC-P1-4, Rev 8.00, May 21, 2008.

² C_b is the total capacitance of one bus line in picofarads (pF). If mixed with high speed (HS) mode devices, faster rise/fall times are allowed (refer to the Philips *I²C Bus Specification, Version 2.1*).

³ Required accuracy in dc-coupled mode is guaranteed by design as long as the clock common-mode voltage output matches the reference clock common-mode voltage range.

TIMING DIAGRAMS

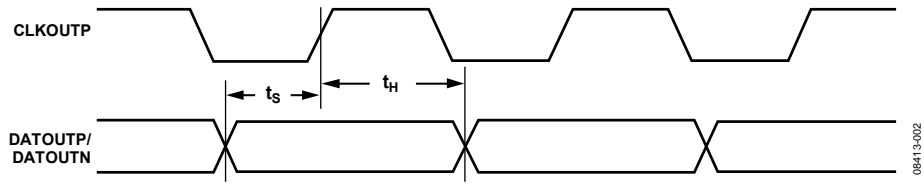

Figure 2. Data to Clock Timing (Full Rate Clock Mode)

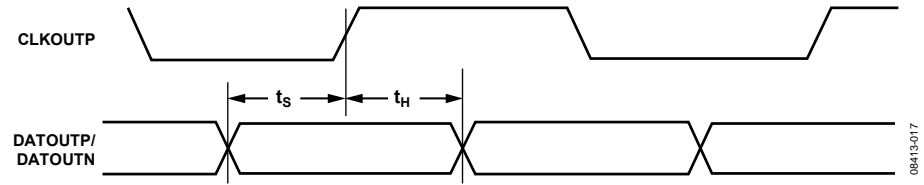

Figure 3. Data to Clock Timing (Half-Rate Clock/DDR Mode)

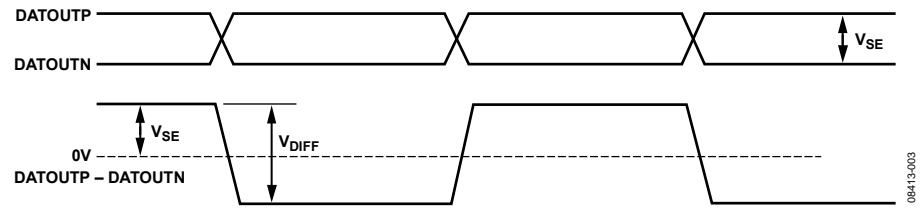

Figure 4. Single-Ended vs. Differential Output Amplitude Relationship

ABSOLUTE MAXIMUM RATINGS

Table 4.

| Parameter | Rating |
|---|------------------|
| Supply Voltage (VCC = 1.2 V) | 1.26 V |
| Supply Voltage (VDD and VCC1 = 3.3 V) | 3.63 V |
| Maximum Input Voltage (REFCLKP/REFCLKN, NIN/PIN) | 1.26 V |
| Minimum Input Voltage (REFCLKP/REFCLKN, NIN/PIN) | $V_{EE} - 0.4$ V |
| Maximum Input Voltage (SDA, SCK, I ² C_ADDR) | 3.63 V |
| Minimum Input Voltage (SDA, SCK, I ² C_ADDR) | $V_{EE} - 0.4$ V |
| Maximum Junction Temperature | 125°C |
| Storage Temperature Range | -65°C to +150°C |
| Lead Temperature (Soldering, 10 sec) | 300°C |

Stresses at or above those listed under Absolute Maximum Ratings may cause permanent damage to the product. This is a stress rating only; functional operation of the product at these or any other conditions above those indicated in the operational section of this specification is not implied. Operation beyond the maximum operating conditions for extended periods may affect product reliability.

THERMAL CHARACTERISTICS

Thermal Resistance

Thermal resistance is specified for the worst-case conditions, that is, a device soldered in a circuit board for surface-mount packages, for a 4-layer board with the exposed paddle soldered to VEE.

Table 5. Thermal Resistance

| Package Type | θ_{JA} ¹ | θ_{JB} ² | θ_{JC} ³ | Unit |
|---------------|----------------------------|----------------------------|----------------------------|------|
| 24-Lead LFCSP | 45 | 5 | 11 | °C/W |

¹ Junction to ambient.

² Junction to base.

³ Junction to case.

ESD CAUTION



ESD (electrostatic discharge) sensitive device. Charged devices and circuit boards can discharge without detection. Although this product features patented or proprietary protection circuitry, damage may occur on devices subjected to high energy ESD. Therefore, proper ESD precautions should be taken to avoid performance degradation or loss of functionality.

PIN CONFIGURATION AND FUNCTION DESCRIPTIONS

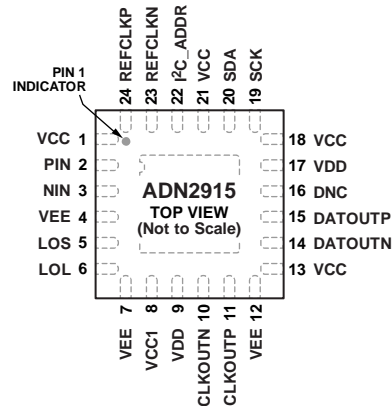

NOTES

1. DNC = DO NOT CONNECT.
2. EXPOSED PADDLE ON BOTTOM OF DEVICE PACKAGE MUST BE CONNECTED TO VEE ELECTRICALLY.

08413-004

Figure 5. Pin Configuration

Table 6. Pin Function Descriptions

| Pin No. | Mnemonic | Type ¹ | Description |
|---------|-----------------------|-------------------|--|
| 1 | VCC | P | 1.2 V Supply for Limiting Amplifier. |
| 2 | PIN | AI | Positive Differential Data Input (CML). |
| 3 | NIN | AI | Negative Differential Data Input (CML). |
| 4 | VEE | P | Ground for Limiting Amplifier. |
| 5 | LOS | DO | Loss of Signal Output (Active High). |
| 6 | LOL | DO | Loss of Lock Output (Active High). |
| 7 | VEE | P | Digital Control Oscillator (DCO) Ground. |
| 8 | VCC1 | P | 1.8 V to 3.3 V DCO Supply. |
| 9 | VDD | P | 3.3 V High Supply. |
| 10 | CLKOUTN | DO | Negative Differential Recovered Clock Output (CML). |
| 11 | CLKOUTP | DO | Positive Differential Recovered Clock Output (CML). |
| 12 | VEE | P | Ground for CML Output Drivers. |
| 13 | VCC | P | 1.2 V Supply for CML Output Drivers. |
| 14 | DATOUTN | DO | Negative Differential Retimed Data Output (CML). |
| 15 | DATOUTP | DO | Positive Differential Retimed Data Output (CML). |
| 16 | DNC | DI | Do Not Connect. Tie off to ground. |
| 17 | VDD | P | 3.3 V High Supply. |
| 18 | VCC | P | 1.2 V Core Digital Supply. |
| 19 | SCK | DI | Clock for I ² C. |
| 20 | SDA | DIO | Bidirectional Data for I ² C. |
| 21 | VCC | P | 1.2 V Core Supply. |
| 22 | I ² C_ADDR | DI | Sets the device I ² C address = 0x80 when I ² C_ADDR = 0, and the device I ² C address = 0x82 when I ² C_ADDR = 1. |
| 23 | REFCLKN | DI | Negative Reference Clock Input (Optional). |
| 24 | REFCLKP | DI | Positive Reference Clock Input (Optional). |
| | EPAD | P | Exposed Pad (VEE). The exposed pad on the bottom of the device package must be connected to VEE electrically. The exposed pad works as a heat sink. |

¹ P = power, AI = analog input, DI = digital input, DO = digital output, DIO = digital input/output.

TYPICAL PERFORMANCE CHARACTERISTICS

$T_A = 25^\circ\text{C}$, $V_{CC} = 1.2\text{ V}$, $V_{CC1} = 1.8\text{ V}$, $V_{DD} = 3.3\text{ V}$, $V_{EE} = 0\text{ V}$, input data pattern: PRBS $2^{15} - 1$, ac-coupled inputs and outputs, unless otherwise noted.

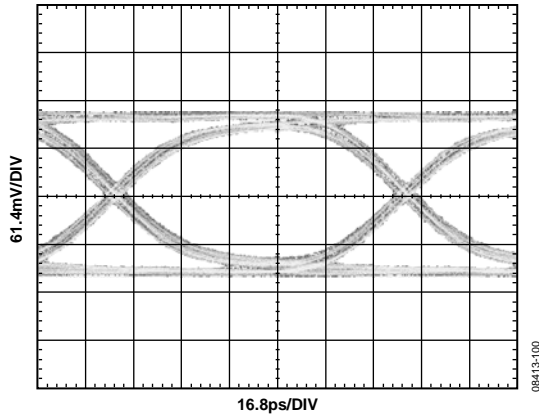

Figure 6. Output Eye Diagram at OC-192

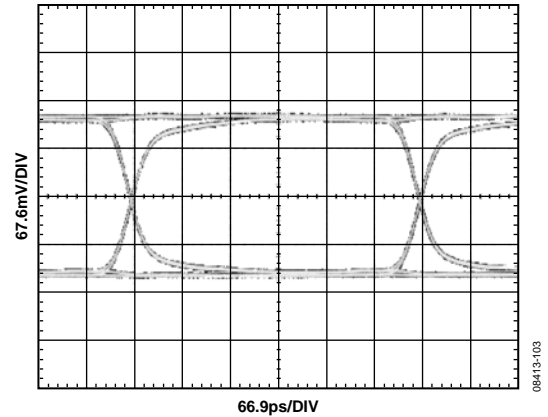

Figure 9. Output Eye Diagram at OC-48

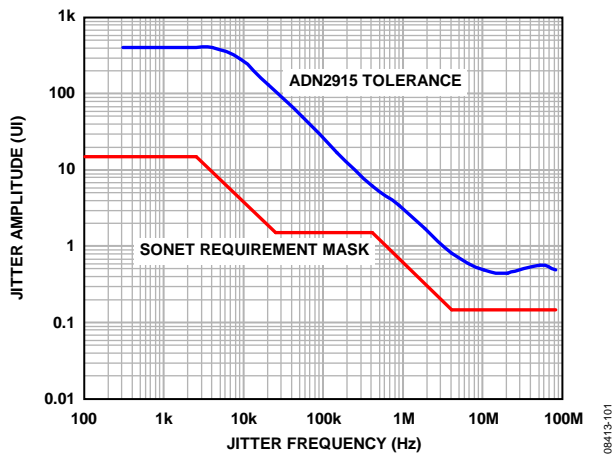

Figure 7. Jitter Tolerance: OC-192

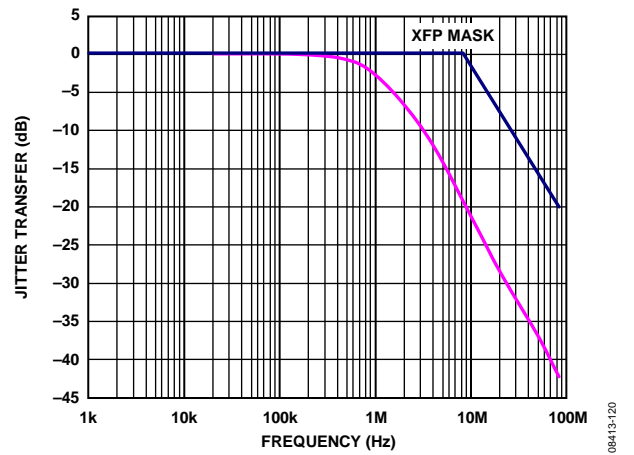

Figure 10. Jitter Transfer: OC-192 (TRANBW[2:0] = 3)

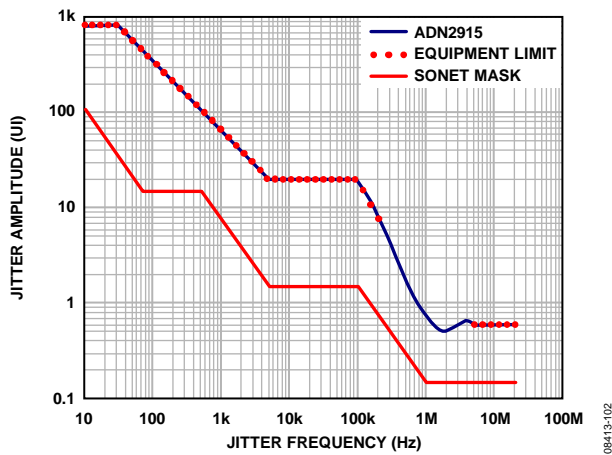

Figure 8. Jitter Tolerance: OC-48

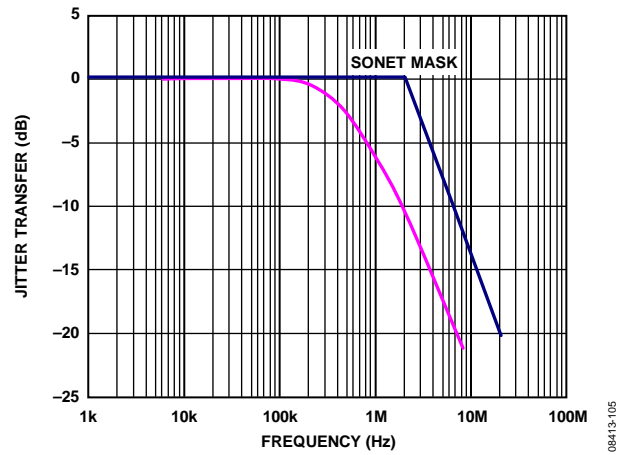

Figure 11. Jitter Transfer: OC-48

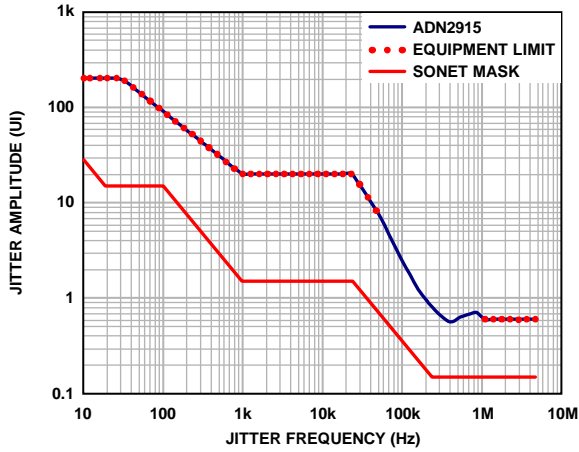

Figure 12. Jitter Tolerance: OC-12

08413-106

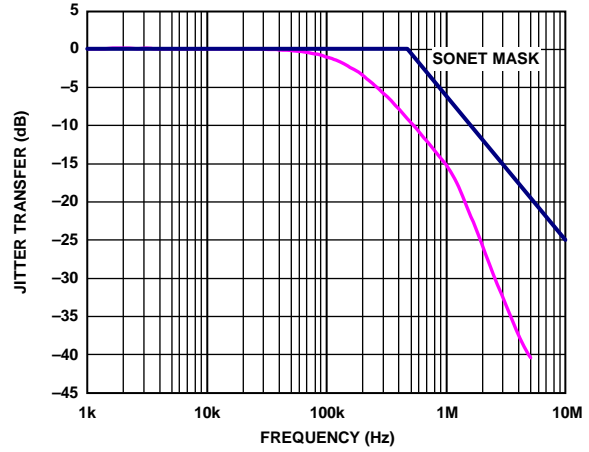

Figure 15. Jitter Transfer: OC-12

08413-109

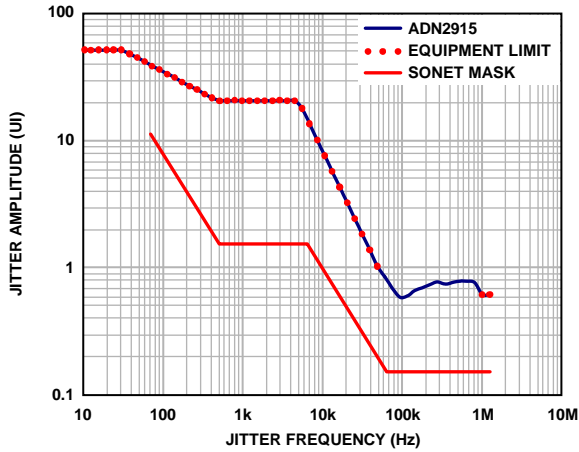

Figure 13. Jitter Tolerance: OC-3

08413-107

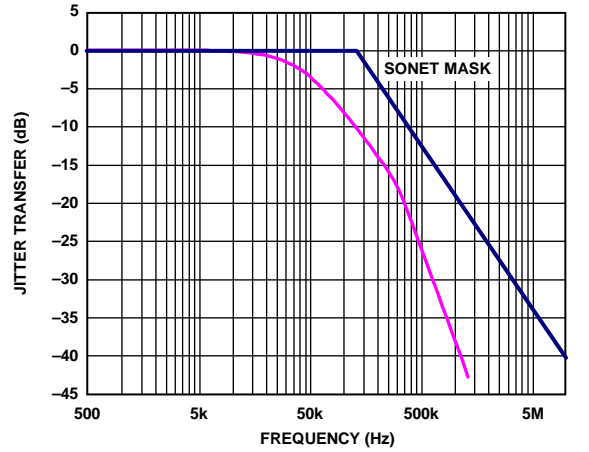

Figure 16. Jitter Transfer: OC-3

08413-110

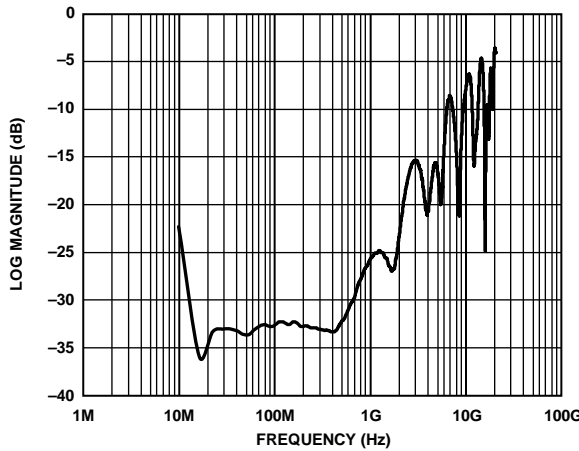

Figure 14. Typical S11 Spectrum Performance

08413-114

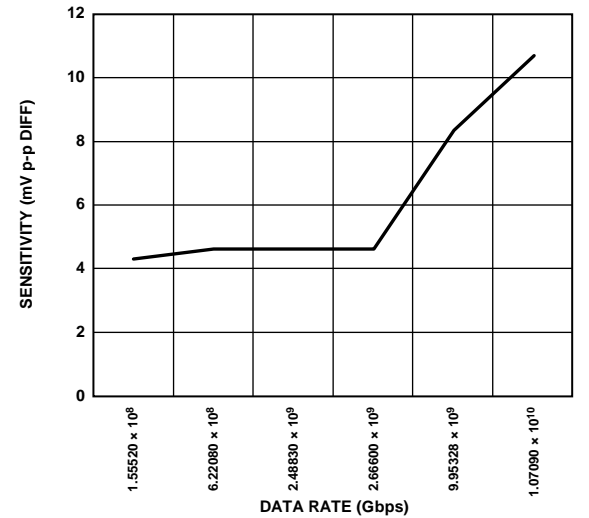
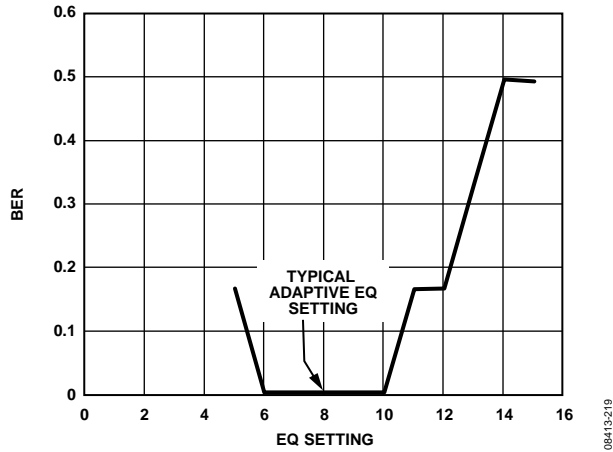

Figure 17. Sensivities of SONET/SDH Data Rates (BER = 10⁻¹⁰)

08413-121



08413-219

Figure 18. BER in Equalizer Mode vs. EQ Compensation at OC-192 (Measured with a OC-192 Signal of 400 mV p-p diff, on 15-Inch FR4 Traces, with Variant EQ Compensation, Including Adaptive EQ)

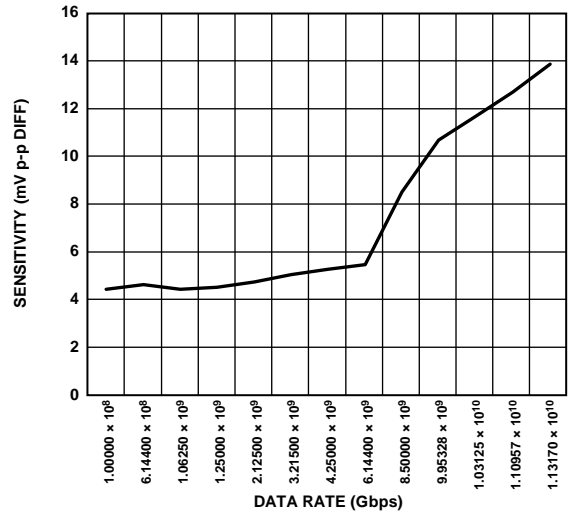

08413-122

Figure 19. Sensitivities of Non-SONET/SDH Data Rates (BER = 10⁻¹²)

REGISTER MAP

Writing to register bits other than those clearly labeled is not recommended and may cause unintended results.

Table 7. Internal Register Map

| Reg Name | R/W | Addr (Hex) | Default (Hex) | D7 | D6 | D5 | D4 | D3 | D2 | D1 | D0 | |
|------------------------|-----|------------|---------------|-------------------------------|----------------|-----------------|----------------|------------------------|----------------------|-------------------------|-----------------|--|
| Readback/Status | | | | | | | | | | | | |
| FREQMEAS0 | R | 0x0 | N/A | FREQ0[7:0] (RATE_FREQ[7:0]) | | | | | | | | |
| FREQMEAS1 | R | 0x1 | N/A | FREQ1[7:0] (RATE_FREQ[15:8]) | | | | | | | | |
| FREQMEAS2 | R | 0x2 | N/A | FREQ2[7:0] (RATE_FREQ[23:16]) | | | | | | | | |
| FREQ_RB1 | R | 0x4 | N/A | VCOSEL[7:0] | | | | | | | | |
| FREQ_RB2 | R | 0x5 | N/A | | FULLRATE | DIVRATE[3:0] | | | | VCOSEL[9:8] | | |
| STATUSA | R | 0x6 | N/A | | | LOS status | LOL status | LOS done | Static LOL | | RATE_MEAS_COMP | |
| General Control | | | | | | | | | | | | |
| CTRLA | R/W | 0x8 | 0x00 | 0 | CDR_MODE[2:0] | | | 0 | Reset static LOL | RATE_MEAS_EN | RATE_MEAS_RESET | |
| CTRLB | R/W | 0x9 | 0x00 | SOFTWARE_RESET | INIT_FREQ_ACQ | CDR bypass | LOL config | LOS PDN | LOS polarity | 0 | 0 | |
| CTRLC | R/W | 0xA | 0x05 | 0 | 0 | 0 | 0 | 0 | REFCLK_PDN | 0 | 1 | |
| FLL Control | | | | | | | | | | | | |
| LTR_MODE | R/W | 0xF | 0x00 | 0 | LOL data | FREF_RANGE[1:0] | | DATA_TO_REF_RATIO[3:0] | | | | |
| D/PLL Control | | | | | | | | | | | | |
| DPLLA | R/W | 0x10 | 0x1C | 0 | 0 | 0 | EDGE_SEL[1:0] | | TRANBW[2:0] | | | |
| DPLLD | R/W | 0x13 | 0x06 | 0 | 0 | 0 | 0 | 0 | ADAPTIVE_SLICE_EN | DLL_SLEW[1:0] | | |
| Phase | R/W | 0x14 | 0x00 | 0 | 0 | 0 | 0 | SAMPLE_PHASE[3:0] | | | | |
| Slice | W | 0x15 | N/A | Extended slice | Slice[6:0] | | | | | | | |
| LA_EQ | R/W | 0x16 | 0x08 | RX_TERM_FLOAT | INPUT_SEL[1:0] | | ADAPTIVE_EQ_EN | EQ_BOOST[3:0] | | | | |
| Slice Readback | R | 0x73 | N/A | SLICE_RB[7:0] | | | | | | | | |
| Output Control | | | | | | | | | | | | |
| OUTPUTA | R/W | 0x1E | 0x00 | 0 | 0 | Data squelch | DATOUT_DISABLE | CLKOUT_DISABLE | DDR_DISABLE | DATA_POLARITY | CLOCK_POLARITY | |
| OUTPUTB | R/W | 0x1F | 0xCC | DATA_SWING[3:0] | | | | CLOCK_SWING[3:0] | | | | |
| LOS Control | | | | | | | | | | | | |
| LOS_DATA | R/W | 0x36 | 0x00 | LOS_DATA[7:0] | | | | | | | | |
| LOS_CTRL | R/W | 0x74 | 0x00 | 0 | 0 | LOS_WRITE | LOS_ENABLE | LOS_RESET | LOS_ADDRESS[2:0] | | | |
| LOS_THRESH | R/W | 0x38 | 0x0A | LOS_THRESHOLD[7:0] | | | | | | | | |
| PRBS Control | | | | | | | | | | | | |
| PRBS Gen 1 | R/W | 0x39 | 0x00 | 0 | 0 | DATA_CID_BIT | DATA_CID_EN | 0 | DATA_GEN_EN | DATA_GEN_MODE[1:0] | | |
| PRBS Gen 2 | R/W | 0x3A | 0x00 | DATA_CID_LENGTH[7:0] | | | | | | | | |
| PRBS Gen 3 | R/W | 0x3B | 0x00 | PROG_DATA[7:0] | | | | | | | | |
| PRBS Gen 4 | R/W | 0x3C | 0x00 | PROG_DATA[15:8] | | | | | | | | |
| PRBS Gen 5 | R/W | 0x3D | 0x00 | PROG_DATA[23:16] | | | | | | | | |
| PRBS Gen 6 | R/W | 0x3E | 0x00 | PROG_DATA[31:24] | | | | | | | | |
| PRBS Rec 1 | R/W | 0x3F | 0x00 | 0 | 0 | 0 | 0 | DATA_RECEIVER_CLEAR | DATA_RECEIVER_ENABLE | DATA_RECEIVER_MODE[1:0] | | |
| PRBS Rec 2 | R | 0x40 | 0x00 | PRBS_ERROR_COUNT[7:0] | | | | | | | | |
| PRBS Rec 3 | R | 0x41 | 0x00 | PRBS_ERROR | | | | | | | | |

| Reg Name | R/W | Addr (Hex) | Default (Hex) | D7 | D6 | D5 | D4 | D3 | D2 | D1 | D0 |
|--------------------|-----|------------|---------------|----|----|----|----|----|----|----|--------------------|
| PRBS Rec 4 | R | 0x42 | N/A | | | | | | | | DATA_LOADED[7:0] |
| PRBS Rec 5 | R | 0x43 | N/A | | | | | | | | DATA_LOADED[15:8] |
| PRBS Rec 6 | R | 0x44 | N/A | | | | | | | | DATA_LOADED[23:16] |
| PRBS Rec 7 | R | 0x45 | N/A | | | | | | | | DATA_LOADED[31:24] |
| ID/Revision | | | | | | | | | | | |
| REV | R | 0x48 | 0x54 | | | | | | | | Rev[7:0] |
| ID | R | 0x49 | 0x15 | | | | | | | | ID[7:0] |

Table 8. Status Register, STATUSA (Address 0x6)

| Bits | Bit Name | Bit Description |
|------|----------------|--|
| D5 | LOS status | 0 = no loss of signal 1 = loss of signal |
| D4 | LOL status | 0 = locked 1 = frequency acquisition mode |
| D3 | LOS done | 0 = LOS action not completed 1 = LOS action completed |
| D2 | Static LOL | 0 = no LOL event since last reset 1 = LOL event since last reset; clear by CTRLA[2] |
| D0 | RATE_MEAS_COMP | Rate measurement complete 0 = frequency measurement incomplete 1 = frequency measurement complete; clear by CTRLA[0] |

Table 9. Control Register, CTRLA (Address 0x8)

| Bits | Bit Name | Bit Description |
|-------|------------------|---|
| D7 | | Reserved to 0. |
| D6:D4 | CDR_MODE[2:0] | CDR modes. 000 = lock to data (LTD). 010 = lock to reference (LTR). 001, 011 = reserved. |
| D3 | | Reserved to 0. |
| D2 | Reset static LOL | Set to 1 to clear static LOL. |
| D1 | RATE_MEAS_EN | Fine data rate measurement enable. Set to 1 to initiate a rate measurement. |
| D0 | RATE_MEAS_RESET | Rate measurement reset. Set to 1 to clear a rate measurement. |

Table 10. Control Register, CTRLB (Address 0x9)

| Bits | Bit Name | Bit Description |
|-------|----------------|---|
| D7 | SOFTWARE_RESET | Software reset. Write a 1 followed by a 0 to reset the part. |
| D6 | INIT_FREQ_ACQ | Initiate frequency acquisition. Write a 1 followed by a 0 to initiate a frequency acquisition (optional). |
| D5 | CDR bypass | CDR bypass. 0 = CDR enabled. 1 = CDR bypassed. |
| D4 | LOL config | LOL configuration. 0 = normal LOL. 1 = static LOL. |
| D3 | LOS PDN | LOS power-down. 0 = normal LOS. 1 = LOS powered down. |
| D2 | LOS polarity | LOS polarity. 0 = active high LOS pin. 1 = active low LOS pin. |
| D1:D0 | | Reserved to 0. |

Table 11. Control Register, CTRLC (Address 0xA)

| Bits | Bit Name | Bit Description |
|-------|------------|--|
| D7:D3 | REFCLK_PDN | Reserved to 0. |
| D2 | | Reference clock power-down. Write a 0 to enable the reference clock. |
| D1 | | Reserved to 0. |
| D0 | | Reserved to 1. |

Table 12. Lock to Reference Clock Mode Programming Register, LTR_MODE¹ (Address 0xF)

| Bits | Bit Name | Bit Description |
|-------|-------------------|--|
| D7 | LOL data | Reserved to 0. |
| D6 | | LOL data 0 = CLK vs. reference clock during tracking 1 = CLK vs. data during tracking |
| D5:D4 | FREF_RANGE[1:0] | f _{REF} range 00 = 11.05 MHz to 22.1 MHz 01 = 22.1 MHz to 44.2 MHz 10 = 44.2 MHz to 88.4 MHz 11 = 88.4 MHz to 176.8 MHz |
| D3:D0 | DATA_TO_REF_RATIO | Data to reference ratio 0000 = 1/2 0001 = 1 0010 = 2 $N = 2^{(n-1)}$ 1010 = 512 |

¹ Where $DIV_{f_{REF}}$ is the divided down reference referred to the 11.05 MHz to 22.1 MHz band (see the Reference Clock (Optional) section).
 $Data\ Rate/2^{(LTR_MODE[3:0]-1)} = REFCLK/2^{(LTR_MODE[5:4])}$

Table 13. D/PLL Control Register, DPLLA (Address 0x10)

| Bits | Bit Name | Bit Description |
|-------|---------------|---|
| D7:D5 | EDGE_SEL[1:0] | Reserved to 0. |
| D4:D3 | | Edge for phase detection. See the Edge Select section for further details. 00 = rising and falling edge data. 01 = rising edge data. 10 = falling edge data. 11 = rising and falling edge data. |
| D2:D0 | | TRANBW[2:0] Transfer bandwidth. Scales transfer bandwidth. Default value is 4, resulting in the OC-192 default BW shown in Table 2. See the Transfer Bandwidth section for further details. $Transfer\ BW = Default\ BW \times (TRANBW[2:0]/4)$ |

Table 14. D/PLL Control Register, DPLLD (Address 0x13)

| Bits | Bit Name | Bit Description |
|-------|-------------------|--|
| D7:D3 | ADAPTIVE_SLICE_EN | Reserved to 0. |
| D2 | | Adaptive slice enable. 1 = enables automatic slice adjust. |
| D1:D0 | | DLL_SLEW[1:0] DLL slew. Sets the BW of the DLL. See the DLL Slew section for further details. |

Table 15. Phase Control Register, Phase (Address 0x14)

| Bits | Bit Name | Bit Description |
|-------|-------------------|---|
| D7:D4 | SAMPLE_PHASE[3:0] | Reserved to 0. |
| D3:D0 | | Adjust the phase of the sampling instant for data rates above 5.65 Gbps in steps of 1/32 UI. This register is in twos complement notation. See the Sample Phase Adjust section for further details. |

Table 16. Slice Level Control Register, Slice (Address 0x15)

| Bits | Bit Name | Bit Description |
|-------|----------------|--|
| D7 | Extended slice | Extended slice enable. 0 = normal slice mode. 1 = extended slice mode. |
| D6:D0 | Slice[6:0] | Slice. Slice is a digital word that sets the input threshold. See the Slice Adjust section for further details. When Slice[6:0] = 0000000, the slice function is disabled. |

Table 17. Input Stage Programming Register, LA_EQ (Address 0x16)

| Bits | Bit Name | Bit Description |
|-------|----------------|--|
| D7 | RX_TERM_FLOAT | Rx termination float. 0 = termination common-mode driven. 1 = termination common-mode floated. |
| D6:D5 | INPUT_SEL[1:0] | Input stage select. 00: limiting amplifier. 01: equalizer. 10: 0 dB buffer. 11: undefined. |
| D4 | ADAPTIVE_EQ_EN | Enable adaptive EQ. 0 = manual EQ control. 1 = adaptive EQ enabled. |
| D3:D0 | EQ_BOOST[3:0] | Equalizer gain. These bits set the EQ gain. See the Passive Equalizer section for further details. |

Table 18. Output Control Register, OUTPUTA (Address 0x1E)

| Bits | Bit Name | Bit Description |
|-------|----------------|---|
| D7:D6 | | Reserved to 0. |
| D5 | Data squelch | Squelch 0 = normal data 1 = squelch data |
| D4 | DATOUT_DISABLE | Data output disable 0 = data output enabled 1 = data output disabled |
| D3 | CLKOUT_DISABLE | Clock output disable 0 = clock output enabled 1 = clock output disabled |
| D2 | DDR_DISABLE | Double data rate 0 = DDR clock enabled 1 = DDR clock disabled |
| D1 | DATA_POLARITY | Data polarity 0 = normal data polarity 1 = flip data polarity |
| D0 | CLOCK_POLARITY | Clock polarity 0 = normal clock polarity 1 = flip clock polarity |

Table 19. Output Swing Register, OUTPUTB (Address 0x1F)

| Bits | Bit Name | Bit Description |
|-------|------------------|---|
| D7:D4 | DATA_SWING[3:0] | Adjust data output amplitude. Step size is approximately 50 mV differential. Default register value is 0xC. Typical differential data output amplitudes are 0x1 = invalid. 0x2 = invalid. 0x3 = invalid. 0x4 = 200 mV. 0x5 = 250 mV. 0x6 = 300 mV. 0x7 = 345 mV. 0x8 = 390 mV. 0x9 = 440 mV. 0xA = 485 mV. 0xB = 530 mV. 0xC = 575 mV. 0xD = 610 mV. 0xE = 640 mV. 0xF = 655 mV. |
| D3:D0 | CLOCK_SWING[3:0] | Adjust clock output amplitude. Step size is approximately 50 mV differential. Default register value is 0xC. Typical differential clock output amplitudes are 0x1 = invalid. 0x2 = invalid. 0x3 = invalid. 0x4 = 200 mV. 0x5 = 250 mV. 0x6 = 300 mV. 0x7 = 345 mV. 0x8 = 390 mV. 0x9 = 440 mV. 0xA = 485 mV. 0xB = 530 mV. 0xC = 575 mV. 0xD = 610 mV. 0xE = 640 mV. 0xF = 655 mV. |

THEORY OF OPERATION

The ADN2915 implements a clock and data recovery for data rates between 6.5 Mbps and 11.3 Gbps. A front end is configurable to either amplify or equalize the nonreturn-to-zero (NRZ) input waveform to full-scale digital logic levels, or to bypass a full digital logic signal.

The user can choose among three input stages to process the data: a high gain limiting amplifier with better than 10 mV sensitivity, a high-pass passive equalizer with up to 10 dB of boost at 5 GHz, or a bypass buffer with 600 mV sensitivity.

An on-chip loss of signal (LOS) detector works with the high sensitivity limiting amplifier. The default threshold for the LOS is the sensitivity of the part, with a maximum threshold level of 128 mV p-p. The limiting amplifier slice threshold can use a factory trim setting, a user-defined threshold set by the I²C, or an adjusted level for the best eye opening at the phase detector.

When the input signal is corrupted due to FR-4 or other impairments in the PCB traces, a passive equalizer can be one of the signal integrity options. The equalizer high frequency boost is configurable through the I²C registers, in place of the factory default settings. A user-enabled adaptation is included that automatically adjusts the equalizer to achieve the widest eye opening. The equalizer can be manually set for any data rate, but adaptation is available only at data rates greater than 5.5 Gbps.

When a signal presents to the clock and data recovery (CDR), the ADN2915 is a delay-locked and phase-locked loop circuit for clock recovery and data retiming from an NRZ encoded data stream. Input data is sampled by a high speed clock. A digital downsampler accommodates data rates spanning three orders of magnitude. Downsampled data is applied to a binary phase detector.

The phase of the input data signal is tracked by two separate feedback loops. A high speed delay-locked loop path cascades a digital integrator with a digitally controlled phase shifter on the digital control oscillator (DCO) clock to track the high frequency components of jitter. A separate phase control loop composed of a digital integrator and DCO tracks the low

frequency components of jitter. The initial frequency of the DCO is set by a third loop that compares the DCO frequency with the input data frequency. This third loop also sets the decimation ratio of the digital downsampler.

The delay-locked and phase-locked loops together track the phase of the input data. For example, when the clock lags the input data, the phase detector drives the DCO to higher frequency and decreases the delay of the clock through the phase shifter; both of these actions serve to reduce the phase error between the clock and data. Because the loop filter is an integrator, the static phase error is driven to zero.

Another view of the circuit is that the phase shifter implements the zero required for frequency compensation of a second-order phase-locked loop, and this zero is placed in the feedback path and, thus, does not appear in the closed-loop transfer function. Because this circuit has no zero in the closed-loop transfer, jitter peaking is eliminated.

The delay-locked and phase-locked loops, together, simultaneously provide wideband jitter accommodation and narrow-band jitter filtering. The simplified block diagram in Figure 25 shows that Z(s)/X(s) is a second-order low-pass jitter transfer function that provides excellent filtering. The low frequency pole is formed by dividing the gain of the PLL by the gain of the DLL, where the upsampling and zero-order hold in the DLL has a gain approaching N at the transfer bandwidth of the loop. Note that the jitter transfer has no zero, unlike an ordinary second-order phase-locked loop. This means that the main PLL loop has no jitter peaking. This makes the circuit ideal for signal regenerator applications, where jitter peaking in a cascade of regenerators can contribute to hazardous jitter accumulation.

The error transfer, e(s)/X(s), has the same high-pass form as an ordinary phase-locked loop up to the slew rate limit of the DLL with a binary phase detector. This transfer function is free to be optimized to give excellent wideband jitter accommodation because the jitter transfer function, Z(s)/X(s), provides the narrow-band jitter filtering.

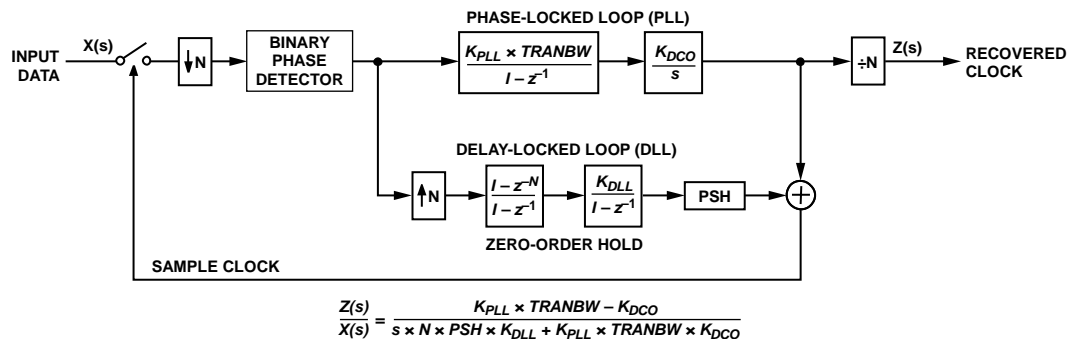

Figure 25. CDR Jitter Block Diagram

The delay-locked and phase-locked loops contribute to overall jitter accommodation. At low frequencies of input jitter on the data signal, the integrator in the loop filter provides high gain to track large jitter amplitudes with small phase error. In this case, the oscillator is frequency modulated and jitter is tracked as in an ordinary phase-locked loop. The amount of low frequency jitter that can be tracked is a function of the DCO tuning range. A wider tuning range gives larger accommodation of low frequency jitter. The internal loop control word remains small for small jitter frequency, so that the phase shifter remains close to the center of its range and, thus, contributes little to the low frequency jitter accommodation.

At medium jitter frequencies, the gain and tuning range of the DCO are not large enough to track input jitter. In this case, the DCO control word becomes large and saturates. As a result, the DCO frequency dwells at an extreme of its tuning range. The

size of the DCO tuning range, therefore, has only a small effect on the jitter accommodation. The delay-locked loop control range is now larger; therefore, the phase shifter takes on the burden of tracking the input jitter. An infinite range phase shifter is used on the clock. Consequently, the minimum range of timing mismatch between the clock at the data sampler and the retiming clock at the output is limited to 32 UI by the depth of the FIFO.

There are two ways to acquire the data rate. The default mode frequency locks to the input data, where a finite state machine extracts frequency measurements from the data to program the DCO and loop division ratio so that the sampling frequency matches the data rate to within 250 ppm. The PLL is enabled, driving this frequency difference to 0 ppm. The second mode is lock to reference, in which case the user provides a reference clock between 11.05 MHz and 176.8 MHz. Division ratios must be written to a serial port register.

FUNCTIONAL DESCRIPTION

FREQUENCY ACQUISITION

The ADN2915 acquires frequency from the data over a range of data frequencies from 6.5 Mbps to 11.3 Gbps. The lock detector circuit compares the frequency of the DCO and the frequency of the incoming data. When these frequencies differ by more than 1000 ppm, LOL is asserted and a new frequency acquisition cycle is initiated. The DCO frequency is reset to the bottom of its range, and the internal division rate is set to its lowest value of $N = 1$, which is the highest octave of data rates. The frequency detector then compares this sampling rate frequency to the data rate frequency and either increases N by a factor of 2 if the sampling rate frequency is found to be greater than the data rate frequency, or increases the DCO frequency if the data rate frequency is found to be greater than the data sampling rate. Initially, the DCO frequency is incremented in large steps to aid fast acquisition. As the DCO frequency approaches the data frequency, the step size is reduced until the DCO frequency is within 250 ppm of the data frequency, at which point LOL is deasserted.

When LOL is deasserted, the frequency-locked loop is turned off. The PLL or DLL pulls in the DCO frequency until the DCO frequency equals the data frequency.

LIMITING AMPLIFIER

The limiting amplifier has differential inputs (PIN and NIN) that are each internally terminated with $50\ \Omega$ to an on-chip voltage reference ($V_{CM} = 0.95\ \text{V}$ typically). The inputs must be ac-coupled. Input offset is factory trimmed to achieve better than 10 mV p-p typical sensitivity with minimal drift. The limiting amplifier can be driven differentially or single-ended. DC coupling of the limiting amplifier is not possible because the user needs to supply a common-mode voltage to exactly match the internal common-mode voltage; otherwise, the internal $50\ \Omega$ termination resistors absorb the difference in common-mode voltages.

Another reason the limiting amplifier cannot be dc-coupled is that the factory trimmed input offset becomes invalid. The offset is adjusted to zero by differential currents from the slice adjust DAC (see Figure 1). With ac coupling, all of the current goes to the $50\ \Omega$ termination resistors on the ADN2915. However, with dc coupling, this current is shared with the external drive circuit, and calibration of the offset is lost. In addition, the slice adjust must have all the current from the slice adjust DAC go to the resistors; otherwise, the calibration is lost (see the Slice Adjust section).

SLICE ADJUST

The quantizer slicing level can be offset by $\pm 100\ \text{mV}$ in 1.6 mV steps or $\pm 15\ \text{mV}$ in 0.24 mV steps to mitigate the effect of amplified spontaneous emission (ASE) noise or duty cycle distortion. Quantizer slice adjust level is set by the slice[6:0] bits in I²C Register 0x15.

Accurate control of the slice threshold requires the user to read back the factory trimmed offset, which is stored as a 7-bit number in the I²C slice readback register (Register 0x73). Use Table 20 to decode the measured offset of the part, where an LSB corresponds to 0.24 mV.

Table 20. Program Slice Level, Normal Slice Mode (Extended Slice = 0)

| Slice[6:0] | Decimal Value | Offset |
|------------|---------------|-------------------------|
| 0000000 | 0 | Slice function disabled |
| 0000001 | 1 | -15 mV |
| ... | ... | ... |
| 1000000 | 64 | 0 mV |
| ... | ... | ... |
| 1111111 | 127 | +14.75 mV |

The amount of offset required for manual slice adjust is determined by subtracting the offset of the part from the desired slice adjust level. Use Table 20 or Table 21 to determine the code word to be written to the I²C slice register.

An extended slice with coarser granularity for each LSB step is found in Table 21. Setting the extended slice bit (Bit 7) = 1 in Register 0x15 scales the full-scale range of the slice adjust by a factor of 6.

Table 21. Program Slice Level, Extended Slice Mode (Extended Slice = 1)

| Slice[6:0] | Decimal Value | Offset |
|------------|---------------|-------------------------|
| 0000000 | 128 | Slice function disabled |
| 0000001 | 129 | -100 mV |
| ... | ... | ... |
| 1000000 | 192 | 0 mV |
| ... | ... | ... |
| 1111111 | 255 | +100 mV |

When manual slice is desired, disable the dc offset loop, which drives duty cycle distortion on the data to 0. Adaptive slice is disabled by setting ADAPTIVE_SLICE_EN = 0 in the DPLL register (0x13).

EDGE SELECT

A binary or Alexander phase detector drives both the DLL and PLL loops at all division rates. Duty cycle distortion on the received data leads to a dead band in the phase detector transfer function if phase errors are measured on both rising and falling data transitions. This dead band leads to jitter generation of unknown spectral composition whose peak-to-peak amplitude is potentially large.

The recommended usage of the part when the dc offset loop is disabled computes phase errors exclusively on either the rising data edges with EDGE_SEL[1:0] (DPLLA[4:3]) = 1 (decimal) or falling data edges with EDGE_SEL[1:0] = 2 in Register 0x10. The alignment of the clock to the rising data edges with EDGE_SEL[1:0] = 1 is represented by the top two curves in

Figure 26. Duty cycle distortion with Narrow 1s moves the significant sampling instance where data is sampled to the right of center. The alignment of the clock to the falling data edges with EDGE_SEL[1:0] = 2 is represented by the first and third curves in Figure 26. The significant sampling instance moves to the left of center. Sample phase adjust for rates above 5.65 Gbps can be used to move the significant sampling instance to the center of the Narrow 1 (or Narrow 0) for best jitter tolerance.

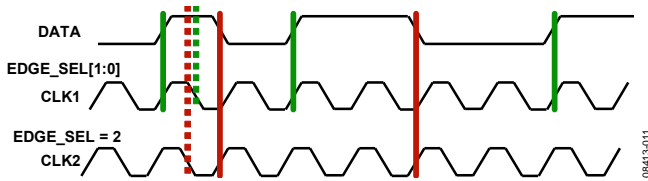

Figure 26. Phase Detector Timing

DLL Slew

Jitter tolerance beyond the transfer bandwidth of the CDR is determined by the slew rate of the delay-locked loop implementing a delta modulator on phase. Setting DLL_SLEW[1:0] = 2, the default value, in the DPLLD register (Register 0x13) configures the DLL to track 0.75 UI p-p jitter at the highest frequency breakpoint in the SONET/SDH jitter tolerance mask. This frequency scales with the rate as $f_{p4} = \text{Rate (Hz)}/2500$ (for example, 4 MHz for OC-192). Peak-to-peak tracking in UI at f_{p4} obeys the expression $(1 + \text{DLL_SLEW})/4$ UI p-p.

In some applications, full SONET/SDH jitter tolerance is not needed. In this case, DPLLD[1:0] can be set to 0, giving lower jitter generation on the recovered clock and better high frequency jitter tolerance.

Sample Phase Adjust

The phase of the sampling instant can be adjusted over the I²C when operating at data rates 5.65 Gbps or higher by writing to the SAMPLE_PHASE[3:0] bits (Phase[3:0]) in Register 0x14. This feature allows the user to adjust the sampling instant with the intent of improving the BER and jitter tolerance. Although the default sampling instant chosen by the CDR is sufficient in most applications, when dealing with some degraded input signals, the BER and jitter tolerance performance can be improved by manually adjusting the phase.

There is a total adjustment range of 0.5 UI, with 0.25 UI in each direction, in increments of 1/32 UI. SAMPLE_PHASE[3:0] is a two's complement number, and the relationship between data and the sampling clock is shown in Figure 28.

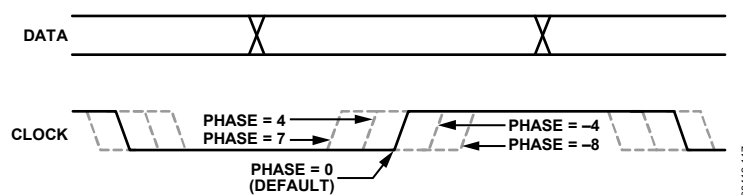

Figure 28. Data vs. Sampling Clock

Transfer Bandwidth

The transfer bandwidth can be adjusted over the I²C by writing to TRANBW[2:0] in the DPLLA register (Register 0x10). The default value is 4. When set to values below 4, the transfer bandwidth is reduced, and when set to values above 4, the transfer bandwidth is increased. The resulting transfer bandwidth is based on the following formula:

$$\text{Transfer BW} = (\text{Default Transfer BW}) \times \left(\frac{\text{TRANBW}[2:0]}{4} \right)$$

For example, at OC-192, the default transfer bandwidth is 2 MHz. The resulting transfer bandwidth when TRANBW[2:0] is changed is

- TRANBW[2:0] = 1: transfer BW = 500 kHz
- TRANBW[2:0] = 2: transfer BW = 1.0 MHz
- TRANBW[2:0] = 3: transfer BW = 1.5 MHz
- TRANBW[2:0] = 4: transfer BW = 2.0 MHz (default)
- TRANBW[2:0] = 5: transfer BW = 2.5 MHz
- TRANBW[2:0] = 6: transfer BW = 3.0 MHz
- TRANBW[2:0] = 7: transfer BW = 3.5 MHz

Reducing the transfer bandwidth is commonly used in OTN applications. Never set TRANBW[2:0] = 0, because this makes the CDR open loop. Also, note that setting TRANBW[2:0] above 4 may cause a slight increase in jitter generation and potential jitter peaking.

LOSS OF SIGNAL (LOS) DETECTOR

The receiver front-end LOS detector circuit detects when the input signal level falls below a user-adjustable threshold.

There is typically 6 dB of electrical hysteresis on the LOS detector to prevent chatter on the LOS pin. This means that, if the input level drops below the programmed LOS threshold, causing the LOS pin to assert, the LOS pin is not deasserted until the input level has increased to 6 dB (2x) above the LOS threshold (see Figure 27).

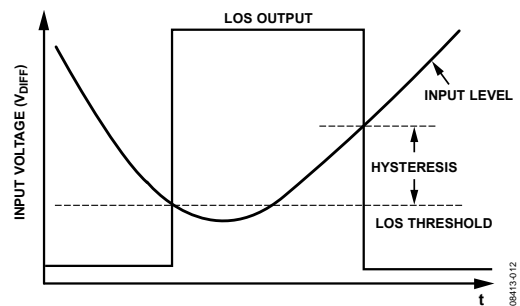

Figure 27. LOS Detector Hysteresis

The LOS detector and the slice level adjust can be used simultaneously on the ADN2915. Therefore, any offset added to the input signal by the slice adjust pins does not affect the LOS detector measurement of the absolute input level.

LOS Power-Down

The LOS, by default, is enabled and consumes power. The LOS is placed in a low power mode by setting the LOS PDN (CTRLB[3]) = 1 in Register 0x9.

LOS Threshold

The LOS threshold has a range between 0 mV and 128 mV and is set by writing the number of millivolts (mV) to the LOS_DATA register (0x36) followed by toggling the LOS_ENABLE bit in the LOS_CTRL register (Register 0x74) while LOS_ADDRESS is set to 1. The following is a procedure for writing the LOS threshold:

1. Write 0x21 to LOS_CTRL (Register 0x74).
2. Write the desired threshold in millivolts to LOS_DATA (Register 0x36).
3. Write 0x31 to LOS_CTRL (Register 0x74).
4. Write 0x21 to LOS_CTRL (Register 0x74).

The LOS threshold can be set to a value between 0 mV and 63 mV in 1 mV steps and 64 mV to 128 mV in 2 mV steps. In the lower range, all of the bits are active, giving 1 mV/LSB resolution, where Bit D0 is the LSB.

However, in the upper range, Bit D0 is disabled (that is, D0 = 0), making Bit D1 the new LSB and resulting in 2 mV/LSB resolution.

I²C Register LOS_CTRL contains the necessary address and write enable bits to program this LOS threshold.

Signal Strength Measurement

The LOS measures and digitizes the peak-to-peak amplitude of the received signal. A single shot measurement is taken by writing the following sequence of bytes to LOS_CTRL at I²C Address 0x74: 0x7, 0x17, 0x7. Upon LOS_ENABLE going low, the peak-to-peak amplitude in millivolts is loaded into LOS_DATA (Register 0x36). The contents of LOS_DATA change only when LOS_ENABLE (LOS_CTRL[4]) in Register 0x74 is toggled low-high-low while pointing to LOS_ADDRESS[2:0] (LOS_CTRL[2:0]) = 7.

PASSIVE EQUALIZER

A passive equalizer is available at the input to equalize large signals that have undergone distortion due to PCB traces, vias, and connectors. The adaptive EQ functions only at data rates greater than 5.5 Gbps. Therefore, at rates less than 5.5 Gbps, the EQ must be manually set.

The equalizer can be manually set through Register LA_EQ (Register 0x16). An adaptive loop is also available that optimizes the EQ setting based on characteristics of the received eye at the phase detector. If the channel is known in advance, manual set the EQ setting to obtain the best

performance; however, the adaptive EQ finds the best setting in most cases.

Table 22 indicates a typical EQ setting for several trace lengths. The values in Table 22 are based on measurements taken on a test board with simple FR-4 traces. Table 23 lists the typical maximum reach in inches of FR-4 of the EQ at several data rates. If a real channel includes lossy connectors or vias, the FR-4 reach length is lower. For any real-world system, it is highly recommended to test several EQ settings with the real channel to ensure best signal integrity.

Table 22. EQ Settings vs. Trace Length on FR-4

| Trace Length (inches) | Typical EQ Setting |
|-----------------------|--------------------|
| 6 | 10 |
| 10 | 12 |
| 15 | 14 |
| 20 to 30 | 15 |

Table 23. Typical EQ Reach on FR-4 vs. Maximum Data Rates Supported

| Maximum Data Rate (Gbps) | Typical EQ Reach on FR-4 (inches) |
|--------------------------|-----------------------------------|
| 4 | 30 |
| 8 | 20 |
| 10 | 15 |
| 11 | 10 |

BYPASS

The bypass path connects the input signal directly to the digital logic inside the ADN2915. This is useful at lower data rates where the signal is large (therefore, the limiting amplifier is not needed, and power can be saved by deselecting the limiting amplifier) and unimpaired (therefore, the equalizer is not needed). The signal swing of the internal digital circuit is 600 mV p-p differential, the minimum signal amplitude that must be provided as the input in bypass mode.

In bypass mode, the internal 50 Ω termination resistors can be configured in one of two ways, either floated or tied to V_{CC} = 1.2 V (see Figure 33 and Table 26). By setting the RX_TERM_FLOAT bit (D7) in I²C Register LA_EQ (Register 0x16) to 1, these 50 Ω termination resistors are floated internal to the ADN2915 (see Figure 36). By setting RX_TERM_FLOAT bit (D7) to 0, these 50 Ω termination resistors are connected to V_{CC} = 1.2 V (see Figure 37). In both of these termination cases, the user must ensure a valid common-mode voltage on the input.

In the case where the termination is floated, the two 50 Ω resistors are purely a differential termination. The input must conform to the range of signals shown in Figure 39.

In the case of termination to 1.2 V V_{CC} power supply (see Figure 37 and Figure 38), the common-mode voltage is created by joint enterprise between the driver circuit and the 50 Ω resistors on the ADN2915. For example, the driver can be an open-drain switched current (see Figure 37), and the 50 Ω resistors return this current to V_{CC}. In Figure 37, the common-mode voltage is

created by both the current and the resistors. In this case, ensure that the current is a minimum of 6 mA, which gives a single-ended swing of 300 mV or a differential swing of 600 mV p-p differential, with $V_{CM} = 1.05$ V (see Figure 39). The maximum current is 10 mA, which gives a single-ended 500 mV swing and differential 1.0 V p-p, with $V_{CM} = 0.95$ V (see Figure 40).

Another possibility is to have the switched current driver back terminated, as shown in Figure 38, and the two V_{CC} supplies having the same potential. In this example, the current is returned to V_{CC} by two 50 Ω resistors in parallel, or 25 Ω , so that the minimum current is 12 mA and the maximum current is 20 mA.

LOCK DETECTOR OPERATION

The lock detector on the ADN2915 has three modes of operation: normal mode, LTR mode, and static LOL mode.

Normal Mode

In normal mode, the ADN2915 is a continuous rate CDR that locks onto any data rate from 6.5 Mbps to 11.3 Gbps without the use of a reference clock as an acquisition aid. In this mode, the lock detector monitors the frequency difference between the DCO and the input data frequency, and deasserts the loss of lock signal, which appears on LOL, Pin 6, when the DCO is within 250 ppm of the data frequency. This enables the digital PLL (D/PLL), which pulls the DCO frequency in the remaining amount and acquires phase lock. When locked, if the input frequency error exceeds 1000 ppm (0.1%), the loss of lock signal is reasserted and control returns to the frequency loop, which begins a new frequency acquisition. The LOL pin remains asserted until the DCO locks onto a valid input data stream to within 250 ppm frequency error. This hysteresis is shown in Figure 29.

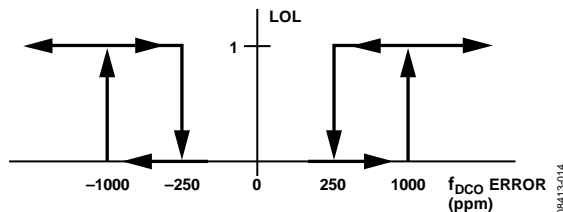

Figure 29. Transfer Function of LOL

LOL Detector Operation Using a Reference Clock

In this mode, a reference clock is used as an acquisition aid to lock the ADN2915 DCO. Lock to reference mode is enabled by setting $CDR_MODE[2:0]$ to 2 in the CTRLA register (Register 0x8). The user must also write to $FREF_RANGE[1:0]$ and $DATA_TO_REF_RATIO[3:0]$ in the LTR_MODE register (Register 0xF) to set the reference frequency range and the divide ratio of the data rate with respect to the reference frequency. Finally, the reference clock power down to the reference clock buffer must be deasserted by writing a 0 to I²C Bit REFCLK_PDN in the CTRLC register (Register 0xA). To maintain fastest acquisition, keep CTRLC[0] set to 1.

For more details, see the Reference Clock (Optional) section. In this mode, the lock detector monitors the difference in frequency between the divided down DCO and the divided down reference clock. The loss of lock signal, which appears on LOL (Pin 6), is deasserted when the DCO is within 250 ppm of the desired frequency. This enables the D/PLL, which pulls in the DCO frequency the remaining amount with respect to the input data and acquires phase lock. When locked, if the frequency error exceeds 1000 ppm (0.1%), the loss of lock signal is reasserted and control returns to the frequency loop, which reacquires with respect to the reference clock. The LOL pin remains asserted until the DCO frequency is within 250 ppm of the desired frequency. This hysteresis is shown in Figure 29.

Static LOL Mode

The ADN2915 implements a static LOL feature that indicates if a loss of lock condition has ever occurred and remains asserted, even if the ADN2915 regains lock, until the static LOL bit (STATUSA[2]) in Register 0x6 is manually reset. If there is ever an occurrence of a loss of lock condition, this bit is internally asserted to logic high. The static LOL bit remains high even after the ADN2915 has reacquired lock to a new data rate. This bit can be reset by writing a 1, followed by 0, to the reset static LOL bit (CTRLA[2]) in I²C Register 0x8. When reset, the static LOL bit (STATUSA[2]) remains deasserted until another loss of lock condition occurs.

Writing a 1 to Bit LOL config (CTRLB[4]) in I²C Register 0x9 causes the LOL pin, Pin 6, to become a static LOL indicator. In this mode, the LOL pin mirrors the contents of the static LOL bit (STATUSA[2]) in Register 0x6 and has the functionality described previously. The LOL config bit (CTRLB[4]) defaults to 0. In this mode, the LOL pin operates in the normal operating mode; that is, it is asserted only when the ADN2915 is in acquisition mode and deasserts when the ADN2915 has reacquired lock.

HARMONIC DETECTOR

The ADN2915 provides a harmonic detector that detects whether the input data has changed to a lower harmonic of the data rate than the one that the sampling clock is currently locked onto. For example, if the input data instantaneously changes from OC-12, 622.08 Mbps, to an OC-3, 155.52 Mbps bit stream, this can be perceived as a valid OC-12 bit stream because the OC-3 data pattern is exactly 4 \times slower than the OC-12 pattern. Therefore, if the change in data rate is instantaneous, a 101 pattern at OC-3 is perceived by the ADN2915 as a 111100001111 pattern at OC-12. If the change to a lower harmonic is instantaneous, a typical inferior CDR may remain locked at the higher data rate.

The ADN2915 implements a harmonic detector that automatically identifies whether the input data has switched to a lower harmonic of the data rate than the DCO is currently locked onto. When a harmonic is identified, the LOL pin is asserted, and a new frequency acquisition is initiated. The ADN2915 automatically locks onto the new data rate, and the LOL pin is deasserted.

The time to detect lock to harmonic is

$$2^{16} \times (T_d/\rho)$$

where:

$1/T_d$ is the new data rate. For example, if the data rate is switched from OC-12 to OC-3, then $T_d = 1/155.52$ MHz.

ρ is the data transition density. Most coding schemes seek to ensure that $\rho = 0.5$, for example, PRBS and 8B/10B.

When the ADN2915 is placed in lock to reference mode, the harmonic detector is disabled.

OUTPUT DISABLE AND SQUELCH

The ADN2915 has two types of output disable/squelch. The DATOUTP/DATOUTN and CLKOUTP/CLKOUTN outputs can be disabled by setting DATOUT_DISABLE (OUTPUTA[4]) and CLKOUT_DISABLE (OUTPUTA[3]) high, respectively, in Register 0x1E. When an output is disabled, it is fully powered down, saving approximately 30 mW per output. Disabling DATOUTP/DATOUTN also disables the CLKOUTP/CLKOUTN output, saving a total of about 60 mW of power.

If it is desired to gate the data output while leaving the clock on, the output data can be squelched by setting the data squelch bit (OUTPUTA[5]) in Register 0x1E high. In this mode, the data driver is left powered, but the data itself is forced to be always 0 (or 1, depending on the setting of DATA_POLARITY (OUTPUTA[1]) in Register 0x1E).

I²C INTERFACE

The ADN2915 supports a 2-wire, I²C-compatible, serial bus driving multiple peripherals. Two inputs, serial data (SDA) and serial clock (SCK), carry information between any devices connected to the bus. Each slave device is recognized by a unique address. The slave address consists of the seven MSBs of an 8-bit word. The upper six bits (Bits[6:1]) of the 7-bit slave address are factory programmed to 100000. The LSB of the slave address (Bit 0) is set by Pin 22, I2C_ADDR. The LSB of the word sets either a read or write operation (see Figure 20). Logic 1 corresponds to a read operation, whereas Logic 0 corresponds to a write operation.

To control the device on the bus, the following protocol must be used. First, the master initiates a data transfer by establishing a start condition, defined by a high-to-low transition on SDA while SCK remains high. This indicates that an address/data stream follows. All peripherals respond to the start condition and shift the next eight bits (the 7-bit address and the R/W bit). The bits are transferred from MSB to LSB. The peripheral that recognizes the transmitted address responds by pulling the data line low during the ninth clock pulse. This is known as an acknowledge bit. All other devices withdraw from the bus at this point and maintain an idle condition. The idle condition is where the device monitors the SDA and SCK lines waiting for the start condition and correct transmitted address. The R/W bit determines the direction of the data. Logic 0 on the LSB of the first byte means that the master writes information to the

peripheral. Logic 1 on the LSB of the first byte means that the master reads information from the peripheral.

The ADN2915 acts as a standard slave device on the bus. The data on the SDA pin is eight bits long, supporting the 7-bit addresses plus the R/W bit. The ADN2915 has subaddresses to enable the user-accessible internal registers (see Table 7).

The ADN2915, therefore, interprets the first byte as the device address and the second byte as the starting subaddress. Auto-increment mode is supported, allowing data to be read from or written to the starting subaddress and each subsequent address without manually addressing the subsequent subaddress. A data transfer is always terminated by a stop condition. The user can also access any unique subaddress register on a one-by-one basis without updating all registers.

Stop and start conditions can be detected at any stage of the data transfer. If these conditions are asserted out of sequence with normal read and write operations, they cause an immediate jump to the idle condition. During a given SCK high period, issue one start condition, one stop condition, or a single stop condition followed by a single start condition. If an invalid subaddress is issued by the user, the ADN2915 does not issue an acknowledge and returns to the idle condition. If the user exceeds the highest subaddress while reading back in auto-increment mode, the highest subaddress register contents continue to be output until the master device issues a no acknowledge. This indicates the end of a read. In a no acknowledge condition, the SDA line is not pulled low on the ninth pulse. See Figure 22 and Figure 21 for sample read and write data transfers, respectively, and Figure 23 for a more detailed timing diagram.

REFERENCE CLOCK (OPTIONAL)

A reference clock is not required to perform clock and data recovery with the ADN2915. However, support for an optional reference clock is provided. The reference clock can be driven differentially or single-ended. If the reference clock is not being used, float both REFCLKP and REFCLKN.

Two 50 Ω series resistors present a differential load between REFCLKP and REFCLKN. Common mode is internally set to $0.56 \times VCC$ by a resistor divider between VCC and VEE. See Figure 30, Figure 31, and Figure 32 for sample configurations.

The reference clock input buffer accepts any differential signal with a peak-to-peak differential amplitude of greater than 100 mV. Phase noise and duty cycle of the reference clock are not critical and 100 ppm accuracy is sufficient.

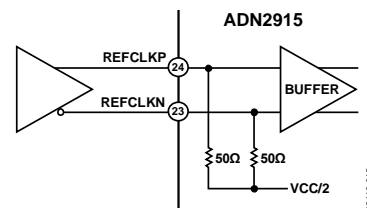

Figure 30. DC-Coupled, Differential REFCLKx Configuration

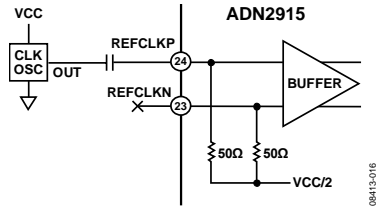

Figure 31. AC-Coupled, Single-Ended REFCLKx Configuration

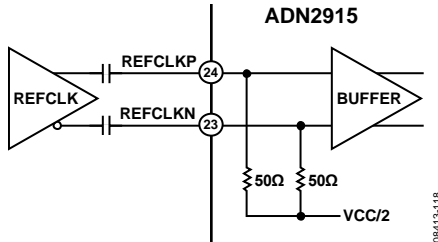

Figure 32. AC-Coupled, Differential REFCLKx Configuration

The reference clock can be used either as an acquisition aid for the ADN2915 to lock onto data, or to measure the frequency of the incoming data to within 0.01%. The modes are mutually exclusive because, in the first use, the user can force the part to lock onto only a known data rate; in the second use, the user can measure an unknown data rate.

Lock to reference mode is enabled by writing a 2 to CDR_MODE[2:0] (CTRLA[6:4]) in Register 0x8. An on-chip clock buffer must be powered on by writing a 0 to REFCLK_PDWN (CTRLC[2]) in Register 0xA. Fine data rate readback mode is enabled by writing a 1 to RATE_MEAS_EN (CTRLA[1]) in Register 0x8. Enabling lock to reference and data rate readback at the same time causes an indeterminate state and is not supported.

Using the Reference Clock to Lock onto Data

In this mode, the ADN2915 locks onto a frequency derived from the reference clock according to the following equation:

$$Data\ Rate/2^{(LTR_MODE[3:0] - 1)} = REFCLK/2^{LTR_MODE[5:4]}$$

The user must know exactly what the data rate is and provide a reference clock that is a function of this rate. The ADN2915 can still be used as a continuous rate device in this configuration if the user has the ability to provide a reference clock that has a variable frequency (see the AN-632 Application Note).

The reference clock can be anywhere between 11.05 MHz and 176.8 MHz. By default, the ADN2915 expects a reference clock of between 11.05 MHz and 22.1 MHz. If it is between 22.1 MHz and 44.2 MHz, 44.2 MHz and 88.4 MHz, or 88.4 MHz and 176.8 MHz, the user must configure the ADN2915 to use the correct reference frequency range by setting the two bits of FREF_RANGE[1:0] (LTR_MODE[5:4]) in Register 0xF.

Table 24. LTR_MODE Settings

| LTR_MODE[5:4] | Range (MHz) | LTR_MODE[3:0] | Ratio |
|---------------|---------------|---------------|------------------|
| 00 | 11.05 to 22.1 | 0000 | 2 ⁻¹ |
| 01 | 22.1 to 44.2 | 0001 | 2 ⁰ |
| 10 | 44.2 to 88.4 | n | 2 ⁿ⁻¹ |
| 11 | 88.4 to 176.8 | 1010 | 2 ⁹ |

The user can specify a fixed integer multiple of the reference clock to lock onto using DATA_TO_REF_RATIO[3:0] (LTR_MODE[3:0]) in Register 0xF. Set

$$DATA_TO_REF_RATIO[3:0] = data\ rate \div DIV_f_{REF}$$

where DIV_f_REF represents the divided-down reference referred to the 11.05 MHz to 22.1 MHz band.

For example, if the reference clock frequency is 38.88 MHz and the input data rate is 622.08 Mbps, then FREF_RANGE[1:0] is set to 01 to give a divided-down reference clock of 19.44 MHz. DATA_TO_REF_RATIO[3:0] is set to 0110, that is, 6, because

$$622.08\ Mbps/19.44\ MHz = 2^{(6 - 1)}$$

While the ADN2915 is operating in lock to reference mode, if the user changes the reference frequency, that is, the f_REF range (LTR_MODE[5:4]) or the f_REF ratio (LTR_MODE[3:0]), this must be followed by writing a 0-1-0 transition into the INIT_FREQ_ACQ (CTRLB[6]) bit in Register 0x9 to initiate a new lock to reference command.

By default in lock to reference clock mode, when lock has been achieved and the ADN2915 is in tracking mode, the frequency of the DCO is being compared to the frequency of the reference clock. If this frequency error exceeds 1000 ppm, lock is lost, LOL is asserted, and it relocks to the reference clock while continuing to output a stable clock.

An alternative configuration is enabled by setting LOL data (LTR_MODE[6]) = 1. In this configuration, when the part is in tracking mode, the frequency of the DCO is being compared to the frequency of the input data, rather than the frequency of the reference clock. If this frequency error exceeds 1000 ppm, lock is lost, LOL is asserted, and it relocks to the reference clock while continuing to output a stable clock.

Using the Reference Clock to Measure Data Frequency

The user can also provide a reference clock to measure the recovered data frequency. In this case, the user provides a reference clock, and the ADN2915 compares the frequency of the incoming data to the incoming reference clock and returns a ratio of the two frequencies to 0.01% (100 ppm). The accuracy error of the reference clock is added to the accuracy of the ADN2915 data rate measurement. For example, if a 100 ppm accuracy reference clock is used, the total accuracy of the measurement is 200 ppm.

The reference clock can range from 11.05 MHz and 176.8 MHz. Prior to reading back the data rate using the reference clock, the LTR_MODE[5:4] bits must be set to the appropriate frequency range with respect to the reference clock being used according to Table 24. A fine data rate readback is then executed as follows:

1. Apply the reference clock.
2. Write a 0 to REFCLK_PDN (CTRLC[2]) in Register 0xA to enable the reference clock circuit.
3. Write to FREQ_RANGE[1:0] (LTR_MODE[5:4]) in Register 0xF to select the appropriate reference clock frequency circuit.
4. Write a 1 to RATE_MEAS_EN (CTRLA[1]) in Register 0x8. This enables the fine data rate measurement capability of the ADN2915. This bit is level sensitive and does not need to be reset to perform subsequent frequency measurements.
5. Write a 0-1-0 to RATE_MEAS_RESET (CTRLA[0]) in Register 0x8. This initiates a new data rate measurement.
6. Read back RATE_MEAS_COMP (STATUSA[0]) in Register 0x6. If it is 0, the measurement is not complete. If it is 1, the measurement is complete and the data rate can be read back on RATE_FREQ[23:0] and FREQ_RB2[6:2] (see Table 7). The approximate time for a data rate measurement is given in Equation 2.

Use the following equation to determine the data rate:

$$f_{\text{Datarate}} = \frac{(\text{RATE_FREQ}[23:0]) \times f_{\text{REFCLK}}}{2^{\text{LTR}[5:4]} \times 2^7 \times 2^{\text{FULLRATE}} \times 2^{\text{DIVRATE}}} \quad (1)$$

where:

f_{Datarate} is the data rate (Mbps).
 $\text{FREQ}[23:0]$ is from FREQ2[7:0] (most significant byte), FREQ1[7:0], and FREQ0[7:0] (least significant byte). See Table 7.
 f_{REFCLK} is the reference clock frequency (MHz).
 $\text{FULLRATE} = \text{FREQ_RB2}[6]$.
 $\text{DIVRATE} = \text{FREQ_RB2}[5:2]$.

| MSB | LSB | |
|------------|------------|------------|
| D23 to D16 | D15 to D8 | D7 to D0 |
| FREQ2[7:0] | FREQ1[7:0] | FREQ0[7:0] |

Consider the example of a 1.25 Gbps (GbE) input signal and a reference clock source of 32 MHz at the PIN/NIN and REFCLKP/REFCLKN ports, respectively. In this case, FREQ_RANGE[1:0] (LTR_MODE[5:4]) = 01 and the reference frequency falls into the range of 22.1 MHz to 44.2 MHz. After following Step 1 through Step 6, the readback value of RATE_FREQ[23:0] is 0x13880, which is equal to 8×10^4 . The readback value of FULLRATE (FREQ_RB2[6]) is 1, and the readback value of DIVRATE[3:0] (FREQ_RB2[5:2]) is 2. Plugging these values into Equation 1 yields

$$((8 \times 10^4) \times (32 \times 10^6)) / (2^1 \times 2^7 \times 2^1 \times 2^2) = 1.25 \text{ Gbps}$$

If subsequent frequency measurements are required, keep RATE_MEAS_EN (CTRLA[1]) set to 1. It does not need to be reset. The measurement process is reset by writing a 1 followed by a 0 to RATE_MEAS_RESET (CTRLA[0]). This initiates a new data rate measurement. Follow Step 2 through Step 6 to

read back the new data rate. Note that a data rate readback is valid only if the LOL pin is low. If LOL is high, the data rate readback is invalid.

Initiating a frequency measurement by writing a 0-1-0 to RATE_MEAS_RESET (CTRLA[0]) also resets the RATE_MEAS_COMP (STATUSA[0]) bit. The approximate time to complete a frequency measurement from RATE_MEAS_RESET (CTRLA[0]) being written with a 0-1-0 transition to when the RATE_MEAS_COMP (STATUSA[0]) bit returns high is given by

$$\text{MeasurementTime} = \frac{2^{11} \times 2^{\text{LTR}[5:4]}}{f_{\text{REFCLK}}} \quad (2)$$

LOS Configuration

The LOS detector output, LOS (Pin 5), can be configured to be either active high or active low. If LOS polarity (CTRLB[2]) in Register 0x9 is set to Logic 0 (default), the LOS pin is active high when a loss of signal condition is detected.

ADDITIONAL FEATURES AVAILABLE VIA THE I²C INTERFACE

Coarse Data Rate Readback

The data rate can be read back over the I²C interface to approximately $\pm 5\%$ without needing an external reference clock according to the following formula:

$$\text{Data} = \frac{f_{\text{DCO}}}{2^{\text{FULLRATE}} \times 2^{\text{DIVRATE}}} \quad (1)$$

where

$\text{FULLRATE} = \text{FREQ_RB2}[6]$.

$\text{DIVRATE} = \text{FREQ_RB2}[5:2]$.

f_{DCO} is the frequency of the DCO, derived as shown in Table 25:

Four oscillator cores defined by VCOSEL[9:8] (FREQ_RB2[1:0]) in Register 0x5 span the highest octave of data rates according to Table 25.

Table 25. DCO Center Frequency vs. VCOSEL[9:8] (FREQ_RB2[1:0])

| Core = (FREQ_RB2[1:0]) | Min Frequency (MHz) = Min_f(core) | Max Frequency (MHz) = Max_f(core) |
|---------------------------|---|---|
| 0 | 5570 | 7105 |
| 1 | 7000 | 8685 |
| 2 | 8610 | 10,330 |
| 3 | 10,265 | 11,625 |

f_{DCO} is determined from FREQ_RB1 and FREQ_RB2[1:0], according to the following formula:

$f_{\text{DCO}} =$

$$\text{Min}_f(\text{core}) + \frac{\text{Max}_f(\text{core}) - \text{Min}_f(\text{core})}{256} \times \text{FREQ_RB1}$$

Worked Example

Read back the contents of the `FREQ_RB1` and `FREQ_RB2` registers. For example, with an OC-192 signal presented to PIN/NIN ports,

```
FREQ_RB1 = 0xCE
FREQ_RB2 = 0x02
FULLRATE (FREQ_RB2[6]) = 0
DIVRATE (FREQ_RB2[5:2]) = 0
core (FREQ_RB2[1:0]) = 2
```

Then

$f_{DCO} =$

$$8610 \text{ Mbps} + \frac{10300 \text{ Mbps} - 8610 \text{ Mbps}}{256} \times 206 = 9994.06 \text{ Mbps}$$

and

$$f_{data} = \frac{9994.06 \text{ Mbps}}{2^0 \times 2^0} = 9.99406 \text{ Gbps}$$

Initiate Frequency Acquisition

A frequency acquisition can be initiated by writing a 1 followed by a 0 to `INIT_FREQ_ACQ` (`CTRLB[6]`) in I²C Register 0x9. This initiates a new frequency acquisition while keeping the ADN2915 in the operating mode that was previously programmed in the `CTRLA`, `CTRLB`, and `CTRLC` registers.

PRBS Generator/Receiver

The ADN2915 has an integrated PRBS generator and detector for system testing purposes. The devices are configurable as either a PRBS detector or a PRBS generator.

The following steps configure the PRBS detector:

1. Set `DATA_RECEIVER_ENABLE` (PRBS Rec 1[2]) to 1 while also setting `DATA_RECEIVER_MODE[1:0]` (PRBS Rec 1[1:0]) according to the desired PRBS pattern (0: PRBS7; 1: PRBS15; 2: PRBS31). Setting `DATA_RECEIVER_MODE[1:0]` to 3 leads to a one-shot sampling of recovered data into `DATA_LOADED[15:0]`.
2. Set `DATA_RECEIVER_CLEAR` (PRBS Rec 1[3]) to 1 followed by 0 to clear `PRBS_ERROR` and `PRBS_ERROR_COUNT`.
3. States of `PRBS_ERROR` (PRBS Rec 3[1]) and `PRBS_ERROR_COUNT[7:0]` (PRBS Rec 2[7:0]) can be frozen by setting `DATA_RECEIVER_ENABLE` (PRBS Rec 1[2]) to 0.

The following steps configure the PRBS generator:

1. Set `DATA_GEN_EN` (PRBS Gen 1[2]) = 1 to enable the PRBS generator while also setting `DATA_GEN_MODE[1:0]` (PRBS Gen 1[1:0]) for a desired PRBS output pattern (0: PRBS7; 1: PRBS15; 2: PRBS31). An arbitrary 32-bit pattern stored as `PROG_DATA[31:0]` is activated by setting `DATA_GEN_MODE[1:0]` to 3.
2. Strings of consecutive identical digits of sensed `DATA_CID_BIT` (PRBS Gen 1[5]) can be introduced in the generator with `DATA_CID_EN` (PRBS Gen 1[4]) set to 1. The length

of CIDs is $8 \times \text{DATA_CID_LENGTH}$, which is set via `PRBS_Gen 2[7:0]` in Register 0x3A.

Table 26. PRBS Settings

| PRBS Patterns | DATA_GEN_MODE[1:0] | PRBS Polynomial |
|-----------------|--------------------|-----------------------|
| PRBS7 | 0x00 | $1 + X^6 + X^7$ |
| PRBS15 | 0x01 | $1 + X^{14} + X^{15}$ |
| PRBS31 | 0x10 | $1 + X^{28} + X^{31}$ |
| PROG_DATA[31:0] | 0x11 | N/A |

Double Data Rate Mode

The default output clock mode is a double data rate (DDR) clock, where the output clock frequency is ½ the data rate. This allows direct interfacing to FPGAs that support clocking on both rising and falling edges. Setting `DDR_DISABLE` (`OUTPUTA[2]`) = 1 in Register 0x1E enables full data rate mode. Full data rate mode is not supported for data rates in the highest octave between 5.6 Gbps and 11.3 Gbps.

CDR Bypass Mode

The CDR in the ADN2915 can be bypassed by setting the CDR bypass bit (`CTRLB[5]`) = 1. In this mode, the ADN2915 feeds the input directly through the input amplifiers to the output buffer, completely bypassing the CDR. The CDR bypass path is intended for use in testing or debugging a system. Use the CDR bypass path at data rates at or below 3.0 Gbps only.

Disable Output Buffers

The ADN2915 provides the option of disabling the output buffers for power savings. The clock output buffer can be disabled by setting Bit `CLKOUT_DISABLE` (`OUTPUTA[3]`) = 1. This reduces the total output power by 30 mW. For a total of 60 mW of power savings, such as in a low power standby mode, both the `CLKOUT` and `DATOUT` buffers can be disabled together by setting Bit `DATOUT_DISABLE` (`OUTPUTA[4]`) = 1.

Transmission Lines

Use of 50 Ω transmission lines is required for all high frequency input and output signals to minimize reflections: `PIN`, `NIN`, `CLKOUTP`, `CLKOUTN`, `DATOUTP`, and `DATOUTN` (also `REFCLKP` and `REFCLKN`, if using a high frequency reference clock, such as 155 MHz). It is also necessary for the `PIN` and `NIN` input traces to be matched in length, and the `CLKOUTP`, `CLKOUTN`, `DATOUTP`, and `DATOUTN` output traces to be matched in length to avoid skew between the differential traces.

The high speed inputs (`PIN` and `NIN`) are each internally terminated with 50 Ω to an internal reference voltage (see Figure 33). As with any high speed, mixed-signal circuit, take care to keep all high speed digital traces away from sensitive analog nodes.

The high speed outputs (`DATOUTP`, `DATOUTN`, `CLKOUTP`, and `CLKOUTN`) are internally terminated with 50 Ω to VCC.

Soldering Guidelines for Lead Frame Chip Scale Package

The lands on the 24-lead LFCSP are rectangular. The printed circuit board pad for these is 0.1 mm longer than the package land length, and 0.05 mm wider than the package land width. Center the land on the pad to ensure that the solder joint size is maximized. The bottom of the lead frame chip scale package has a central exposed pad. The pad on the printed circuit board must be at least as large as this exposed pad. The user must connect the exposed pad to VEE using plugged vias to prevent solder from leaking through the vias during reflow. This ensures a solid connection from the exposed pad to VEE.

It is highly recommended to include as many vias as possible when connecting the exposed pad to VEE. This minimizes the thermal resistance between the die and VEE, and minimizes the die temperature. It is recommended that the vias be connected to a VEE plane, or planes, rather than a signal trace, to improve heat dissipation as shown in Figure 34.

Placing an external VEE plane on the backside of the board opposite the ADN2915 provides an additional benefit because this allows easier heat dissipation into the ambient environment.

INPUT CONFIGURATIONS

The ADN2915 input stage can work with the signal source in either ac-coupled or dc-coupled configuration. To best fit in a required applications environment, the ADN2915 supports one

of following input modes: limiting amplifier, equalizer, or bypass. It is easy to set the ADN2915 to use any required input configuration through the I²C bus. Figure 33 shows a block diagram of the input stage circuit.

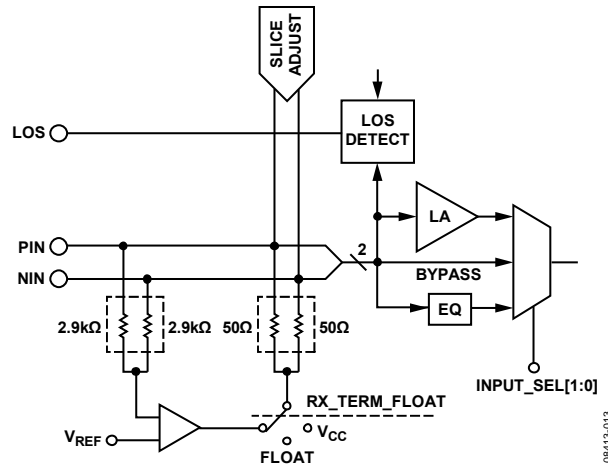

Figure 33. Input Stage Block Diagram

A correct input signal pass is configurable with the INPUT_SEL[1:0] bits (LA_EQ[6:5]) in Register 0x16. Table 27 shows the INPUT_SEL[1:0] bits and the input signal configuration.

Table 27. Input Signal Configuration

| Selected Input | INPUT_SEL[1:0] | RX_TERM_FLOAT = 0 | RX_TERM_FLOAT = 1 |
|----------------------|----------------|-------------------|-------------------|
| Limiting Amplifier | 00 | V _{REF} | Not defined |
| Equalizer | 01 | V _{REF} | Not defined |
| Bypass (0 dB Buffer) | 10 | V _{CC} | Float |
| Not Defined | 11 | Not defined | Not defined |

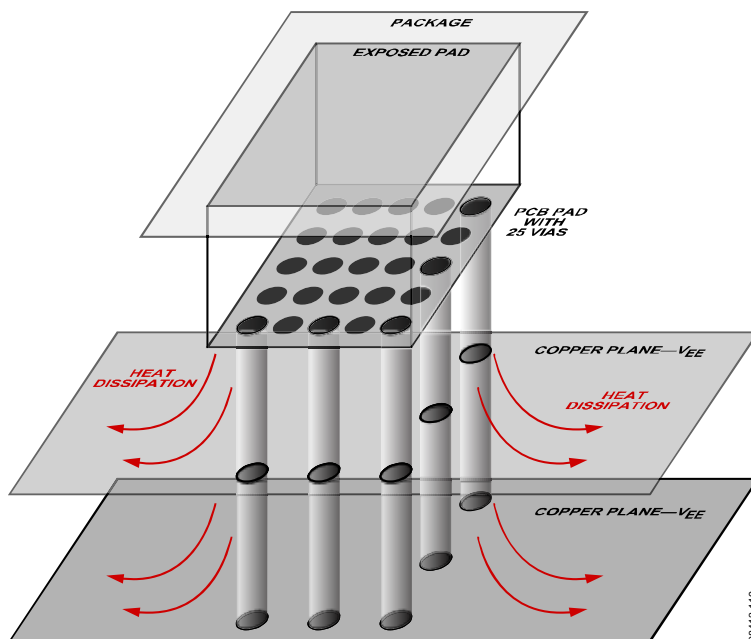

Figure 34. Connecting Vias to VEE

Choosing AC Coupling Capacitors

AC coupling capacitors at the inputs (PIN, NIN) and outputs (DATOUTP, DATOUTN) of the ADN2915 must be chosen such that the device works properly over the full range of data rates used in the application. When choosing the capacitors, the time constant formed with the two 50 Ω resistors in the signal path must be considered. When a large number of consecutive identical digits (CIDs) are applied, the capacitor voltage can droop due to baseline wander (see Figure 35), causing pattern dependent jitter (PDJ).

The user must determine how much droop is tolerable and choose an ac coupling capacitor based on that amount of droop. The amount of PDJ can then be approximated based on the capacitor selection. The actual capacitor value selection may require some trade-offs between droop and PDJ.

For example, assuming that 2% droop is tolerable, the maximum differential droop is 4%.

Normalizing to V p-p,

$$Droop = \Delta V = 0.04 V = 0.5 V_{p-p} (1 - e^{-t/\tau})$$

Therefore,

$$\tau = 12t$$

where:

τ is the RC time constant (C is the ac coupling capacitor, R = 100 Ω seen by C).

t is the total discharge time

$$t = nT$$

where:

n is the number of CIDs.

T is the bit period.

Calculate the capacitor value by combining the equations for τ and t.

$$C = 12nT/R$$

When the capacitor value is selected, the PDJ can be approximated as

$$PDJ_{ps\ p-p} = 0.5t_r(1 - e^{(-nT/RC)})/0.6$$

where:

$PDJ_{ps\ p-p}$ is the amount of pattern dependent jitter allowed, <0.01 UI p-p typical.

t_r is the rise time, which is equal to 0.22/BW; BW ≈ 0.7 (bit rate).

Note that this expression for t_r is accurate only for the inputs. The output rise time for the ADN2915 is ~30 ps regardless of data rate.

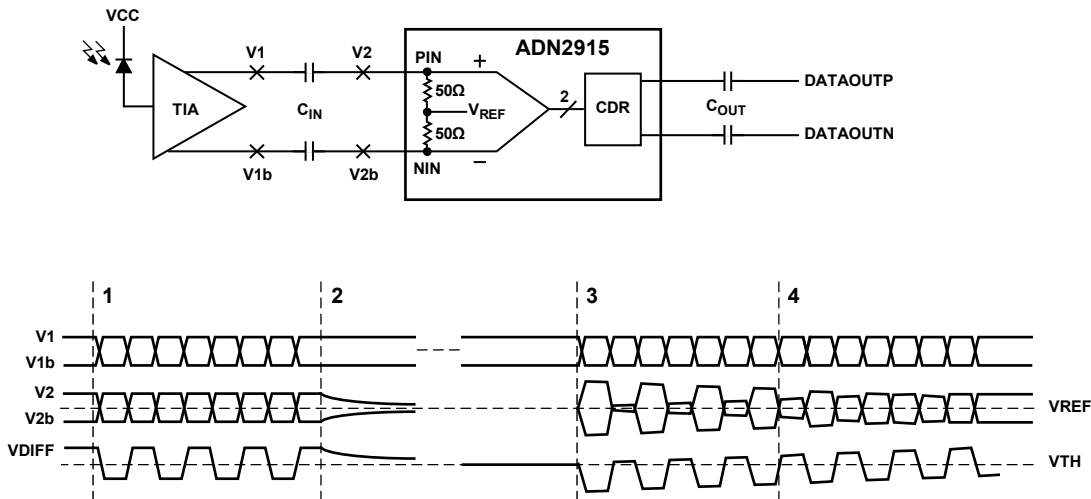

VDIFF = V2 - V2b
VTH = ADN2915 QUANTIZER THRESHOLD

NOTES

1. DURING THE DATA PATTERNS WITH HIGH TRANSITION DENSITY, DIFFERENTIAL DC VOLTAGE AT V1 AND V2 IS ZERO.
2. WHEN THE TIA OUTPUTS CONSECUTIVE IDENTICAL DIGITS, V1 AND V1b ARE DRIVEN TO DIFFERENT DC LEVELS. V2 AND V2b DISCHARGE TO THE V_{REF} LEVEL, WHICH EFFECTIVELY INTRODUCES A DIFFERENTIAL DC OFFSET ACROSS THE AC COUPLING CAPACITORS.
3. WHEN THE BURST OF DATA STARTS AGAIN, THE DIFFERENTIAL DC OFFSET ACROSS THE AC COUPLING CAPACITORS IS APPLIED TO THE INPUT LEVELS, CAUSING A DC SHIFT IN THE DIFFERENTIAL INPUT. THIS SHIFT IS LARGE ENOUGH SUCH THAT ONE OF THE STATES, EITHER HIGH OR LOW, DEPENDING ON THE LEVELS OF V1 AND V1b WHEN THE TIA WENT TO CID, IS CANCELLED OUT. THE QUANTIZER DOES NOT RECOGNIZE THIS AS A VALID STATE.
4. THE DC OFFSET SLOWLY DISCHARGES UNTIL THE DIFFERENTIAL INPUT VOLTAGE EXCEEDS THE SENSITIVITY OF THE ADN2915. THE QUANTIZER RECOGNIZES BOTH HIGH AND LOW STATES AT THIS POINT.

Figure 35. Example of Baseline Wander

DC-COUPLED APPLICATION

The inputs to the ADN2915 can also be dc-coupled. This can be necessary in burst mode applications with long periods of CIDs and where baseline wander cannot be tolerated. If the inputs to the ADN2915 are dc-coupled, care must be taken not to violate the input range and common-mode level requirements of the ADN2915 (see Figure 39 or Figure 40). If dc coupling is required, and the output levels of the transimpedance amplifier (TIA) do not adhere to the levels shown in Figure 39 or Figure 40, level shifting and/or attenuation must occur between the TIA outputs and the ADN2915 inputs.

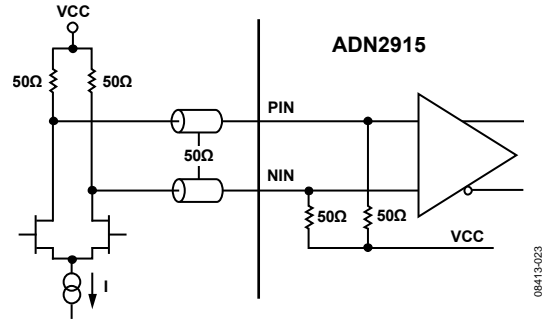

Figure 38. DC-Coupled Application, Bypass Input (Back Terminated Mode)

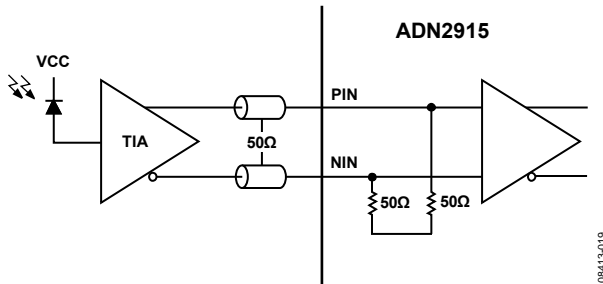

Figure 36. DC-Coupled Application, Bypass Input (Rx Term Float Mode)

Figure 37 shows the default dc-coupled situation when using the bypass input. The two terms are connected directly to VCC in a normal CML fashion, giving a common mode that is set by the dc signal strength from the driving chip. The bypass input has a high common-mode range and can tolerate V_{CM} up to and including VCC.

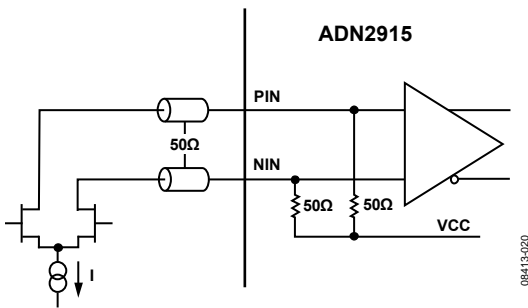

Figure 37. DC-Coupled Application, Bypass Input (Normal Mode)

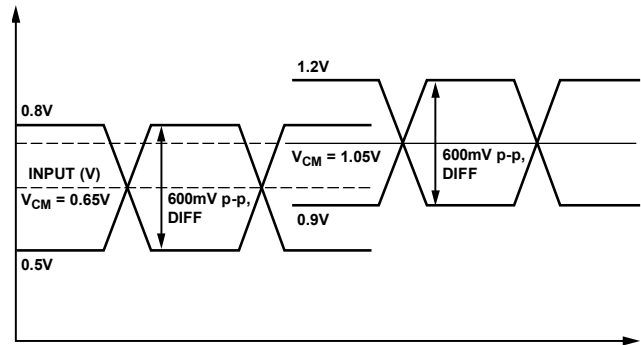

Figure 39. Minimum Allowed DC-Coupled Input Levels

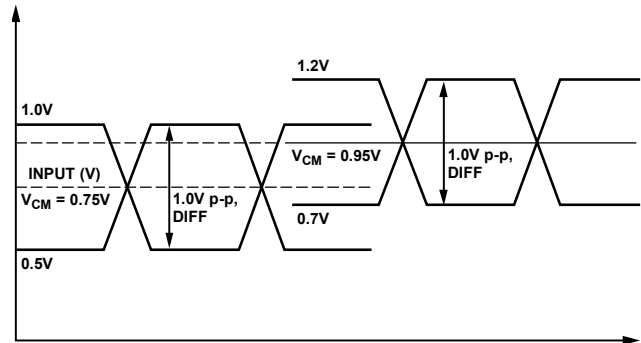
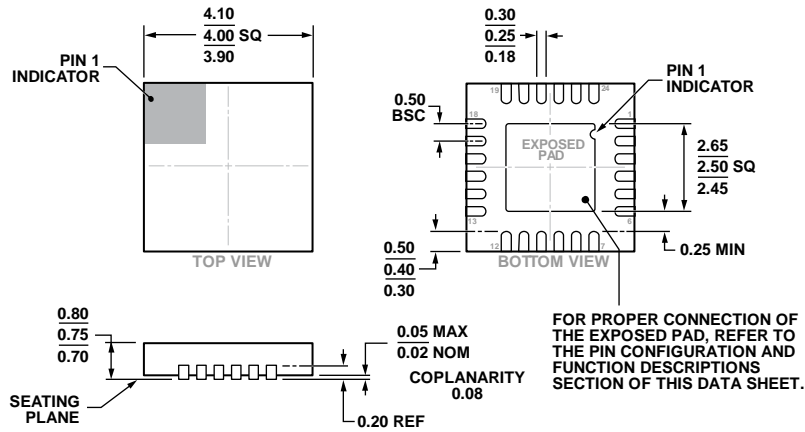

Figure 40. Maximum Allowed DC-Coupled Input Levels

OUTLINE DIMENSIONS



COMPLIANT TO JEDEC STANDARDS MO-220-WGGD.

Figure 41. 24-Lead Lead Frame Chip Scale Package [LFCSP]
 4 mm × 4 mm Body and 0.75 mm Package Height
 (CP-24-7)
 Dimensions shown in millimeters

03-11-2013-A

ORDERING GUIDE

| Model ¹ | Temperature Range | Package Description | Package Option | Ordering Qty |
|--------------------|-------------------|---|----------------|--------------|
| ADN2915ACPZ | -40°C to +85°C | 24-Lead Lead Frame Chip Scale Package [LFCSP] | CP-24-7 | 490 |
| EVALZ-ADN2915 | | Evaluation Board | | |

¹ Z = RoHS Compliant Part.

NOTES

NOTES

NOTES

I²C refers to a communications protocol originally developed by Philips Semiconductors (now NXP Semiconductors).

Looking for pricing, stock, or lifecycle information?

Click below to explore more details on WIN SOURCE:

 [View ADN2915ACPZ on WIN SOURCE](#)

 [Analog Devices Inc. Information](#)

Optimize Your Supply Chain with WIN SOURCE Solutions

-  Global Sourcing Solution
-  Obsolete Management
-  Cost Control Management
-  Shortage Management
-  Alternative Solution
-  Excess Inventory Management