

Applications

- PCS / 3G Base station / Repeaters
- WCDMA / LTE
- ISM / Fixed Wireless
- HPA Feedback Paths

Product Features

- High Dynamic Range Mixer
- Integrated LO Driver
- +36 dBm Input IP3
- 9 dB Conversion Loss
- RF: 700 – 1500 MHz
- LO: 460 – 1640 MHz
- IF: 30 – 300 MHz
- +5 V Supply at 50 mA
- 0 dBm Drive Level
- RoHS-compliant MSOP8 (14 mm²)

General Description

The ML483 high linearity converter combines a passive GaAs FET mixer with an integrated LO driver in an ultra-small lead-free/green/RoHS-compliant MSOP-8 package. The double-balanced integrated IC operates across a 0.7-1.5 GHz frequency range to achieve +36 dBm Input IP3 while drawing a very low 50mA current. The ML483 can be used as an upconverter or downconverter in a low-side or high-side LO configuration.

The integrated LO buffer amplifier enables operation directly from a synthesizer requiring only 0 dBm of drive level. The dual-stage LO driver provides a stable input power level into the mixer to allow for consistent performance over a wide range of LO power levels. The converter requires no external baluns and supports a wide range of IF frequencies.

Typical applications include frequency up/down conversion, modulation and demodulation for receivers and transmitters in mobile infrastructure. Due to the wide frequency range of operation, the converter can also be used for ISM and fixed wireless applications.

The ML483 is footprint and pin compatible with TriQuint's 1.6-3.2 GHz ML485 mixer for high band applications.



8 Pin MSOP Package

Functional Block Diagram

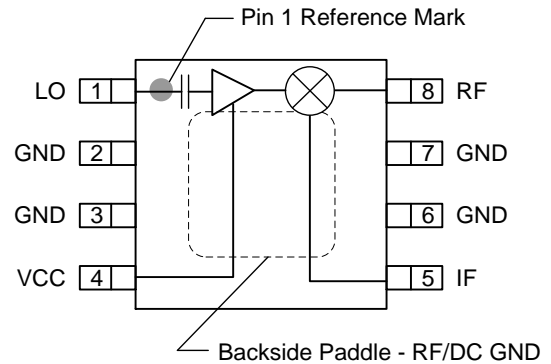

Pin Configuration

| Pin No. | Symbol |
|-----------------|--------|
| 1 | LO |
| 2, 3, 6, 7 | GND |
| 4 | Vcc |
| 5 | IF |
| 8 | RF |
| Backside Paddle | GND |

Ordering Information

| Part No. | Description |
|--|--|
| ML483-G | 0.7 – 1.5 GHz Mixer w/ Integrated LO Amp |
| ML483-PCB | Fully Assembled Evaluation Board |
| Standard T/R size = 1000 pieces on a 7" reel | |

Absolute Maximum Ratings

| Parameter | Rating |
|---------------------------------|----------------|
| Storage Temperature | -65 to +150 °C |
| DC Voltage | +7 V |
| Input IF / RF Power, CW, +25 °C | +27 dBm |
| LO Power | +10 dBm |

Operation of this device outside the parameter ranges given above may cause permanent damage.

Recommended Operating Conditions

| Parameter | Min | Typ | Max | Units |
|--|-------|------|-------|-------|
| V _{CC} | +4.75 | +5.0 | +5.25 | V |
| T _{CASE} | -40 | | +85 | °C |
| RF Input Power | | | +10 | dBm |
| LO Drive Level | -4 | 0 | +4 | dBm |
| T _j for >10 ⁶ hours MTTF | | | +150 | °C |

Electrical specifications are measured at specified test conditions. Specifications are not guaranteed over all recommended operating conditions.

Electrical Specifications

Test conditions unless otherwise noted: V_{CC} = +5 V, I_{CC} = 40 mA, Temp = +25 °C, 50 Ω system. (see note 1)

| Parameter | Min | Typ | Max | Min | Typ | Max | Units |
|------------------------------------|-----|------------|-----|-----|------------|-----|-------|
| RF Frequency Range | | 700 – 800 | | | 800 – 1000 | | MHz |
| LO Frequency Range | | 770 – 1040 | | | 870 – 1240 | | MHz |
| IF Freq Range | | 30 – 240 | | | 30 – 240 | | MHz |
| SSB Conversion Loss ⁽³⁾ | | 9.2 | | | 8.7 | 10 | dB |
| Input IP3 ^(2,3) | | +37 | | +30 | +36 | | dBm |
| LO Leakage RF Port | | -17 | | | -18 | | dBm |
| LO Leakage IF Port | | -11 | | | -15 | | dBm |
| RF–IF Isolation | | 12.5 | | | 16 | | dB |
| RF Return Loss | | 13 | | | 16 | | dB |
| IF Return Loss | | 11 | | | 12 | | dB |
| LO Return Loss | | 11 | | | 14 | | dB |
| Input P1dB | | +24 | | | +23.5 | | dBm |
| LO Drive Level | -4 | 0 | +4 | -4 | 0 | +4 | dBm |
| Thermal Resistance ⁽⁴⁾ | | | 81 | | | 81 | °C/W |

Notes:

- Specifications are shown with 0dBm LO drive and IF = 140 MHz in a down converting configuration with a high-side LO.
- IIP3 is measured with Δf = 1 MHz with RFin = 0 dBm / tone.
- Min/Max conditions tested with LO=1041 MHz, RF=901 MHz, IF=140 MHz
- Thermal resistance is specified junction to case.

Spur Table

| | | M | | | | | |
|---|---|-----|-----|-----|----|-----|-----|
| | | 0 | 1 | 2 | 3 | 4 | 5 |
| N | 0 | -- | 8 | 13 | 15 | 10 | 9 |
| | 1 | 8 | 0 | 43 | 19 | 34 | 22 |
| | 2 | 54 | 59 | 44 | 65 | 53 | 64 |
| | 3 | 85 | 91 | 87 | 79 | 91 | 84 |
| | 4 | 99 | 100 | 100 | 99 | 100 | 98 |
| | 5 | 101 | 100 | 97 | 99 | 99 | 100 |

Spur table is $N \times f_{RF} - M \times f_{LO}$ mixer spurious products for 0 dBm input power, unless otherwise noted.

RF Frequency = 900 MHz
LO Frequency = 1041 MHz
All values in dBc relative to the IF Power Level.

Performance Plots

Test conditions unless otherwise noted: $V_{CC} = +5\text{ V}$, $\text{Temp} = +25^\circ\text{C}$, $50\ \Omega$ system.

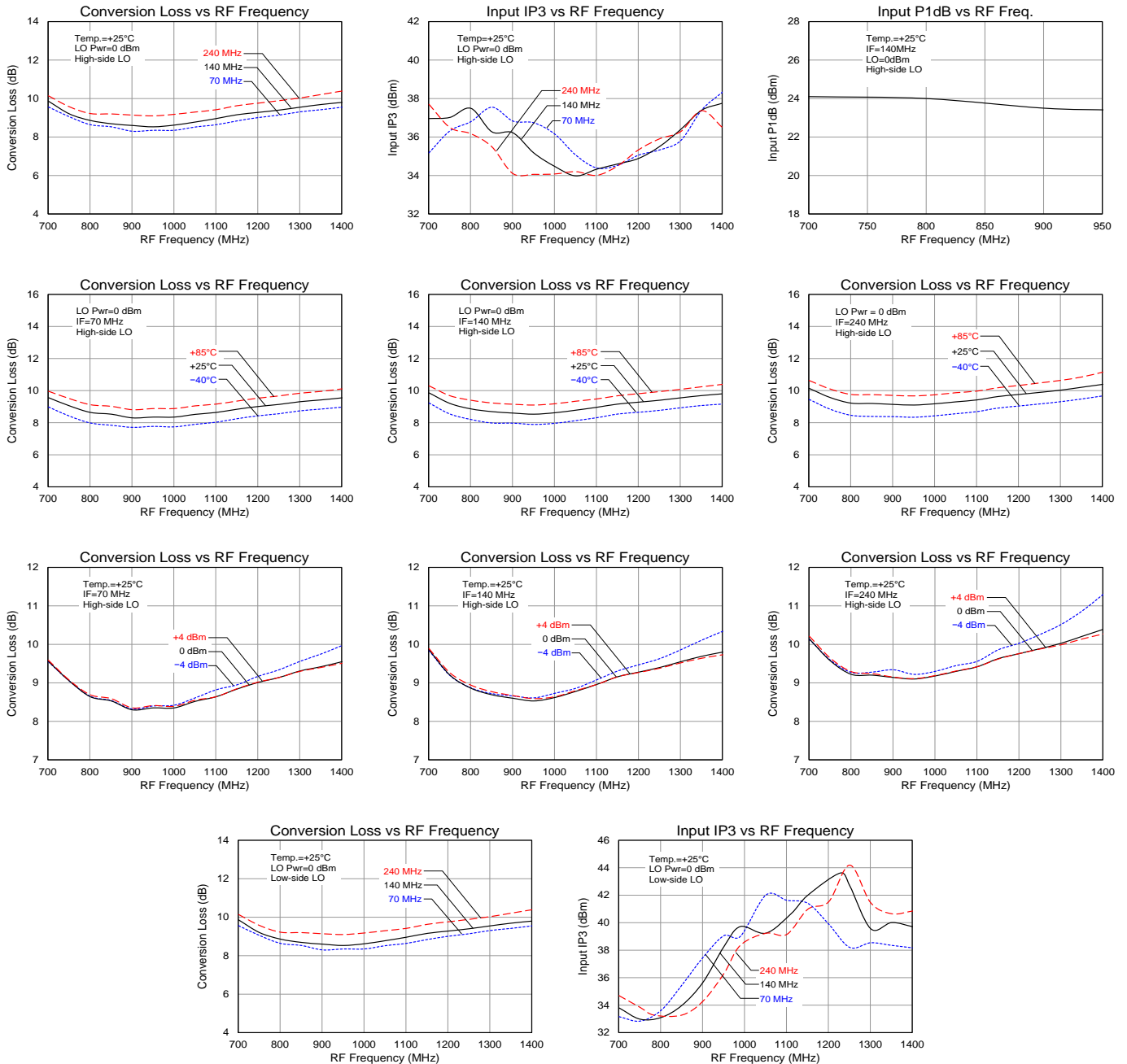

Performance Plots

Test conditions unless otherwise noted: $V_{CC} = +5\text{ V}$, $\text{Temp} = +25\text{ }^\circ\text{C}$, $50\ \Omega$ system.

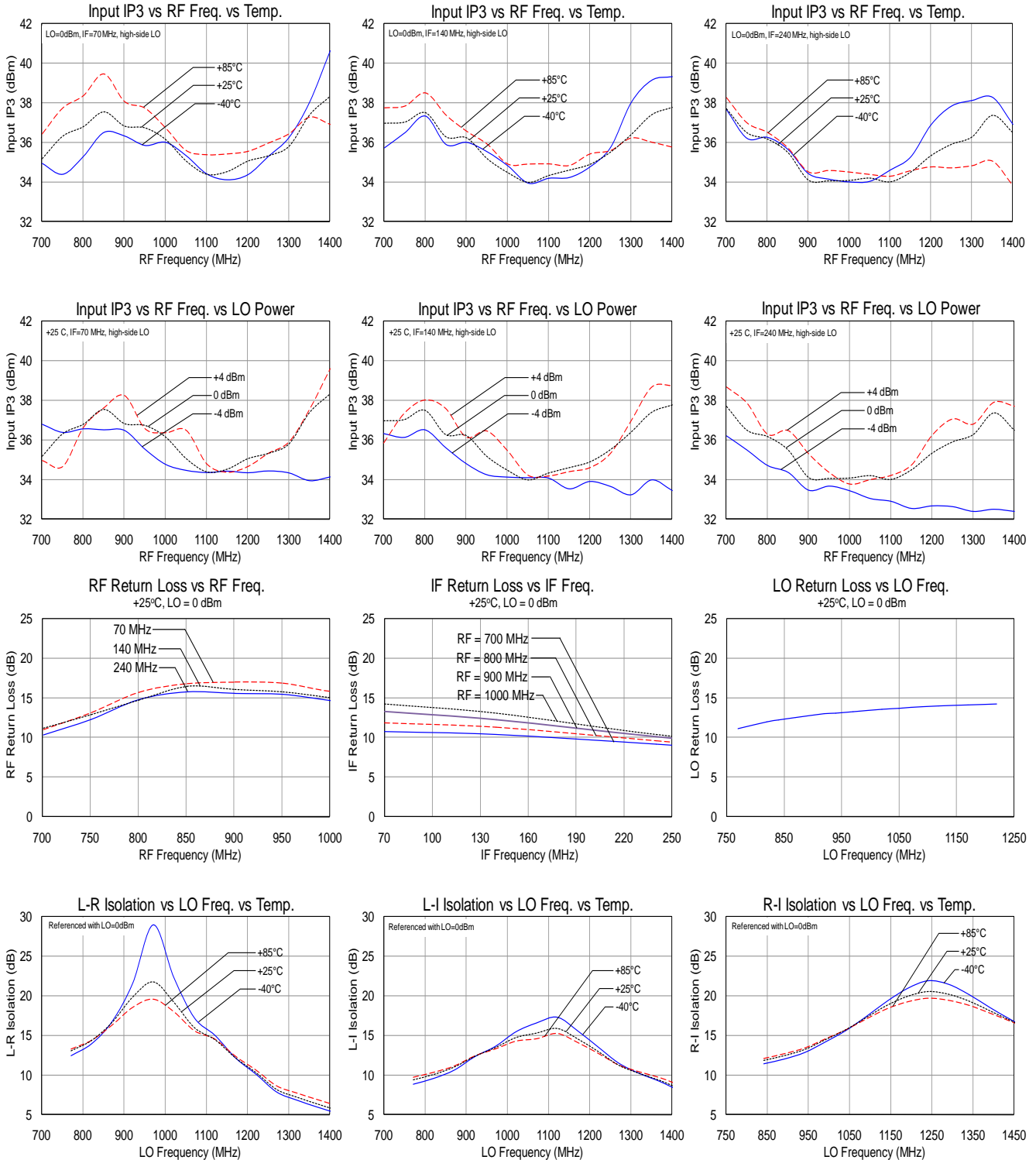

Performance Plots

Test conditions unless otherwise noted: $V_{CC} = +5\text{ V}$, $\text{Temp} = +25\text{ }^\circ\text{C}$, $50\ \Omega$ system.

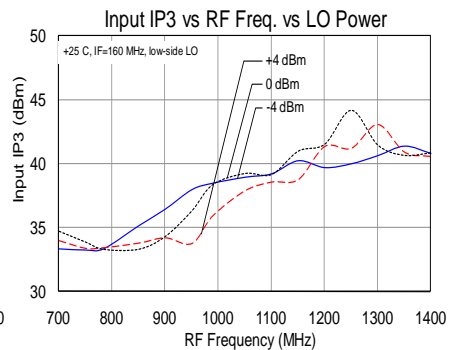
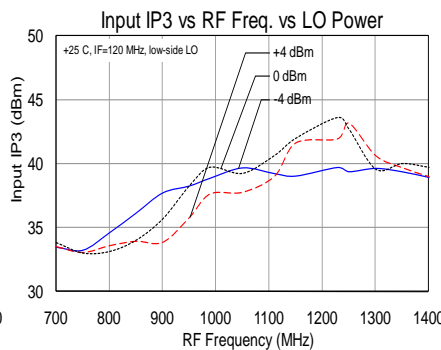
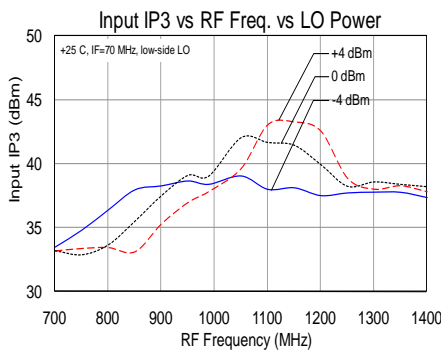
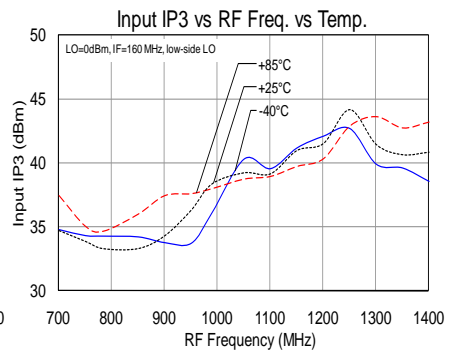
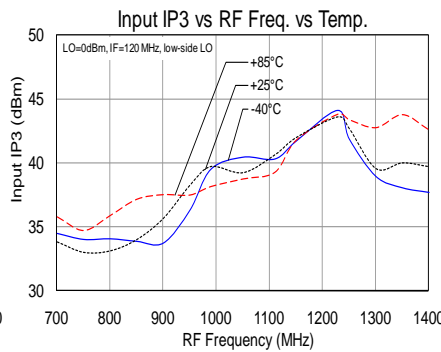
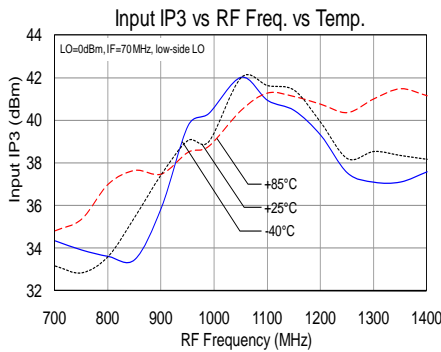
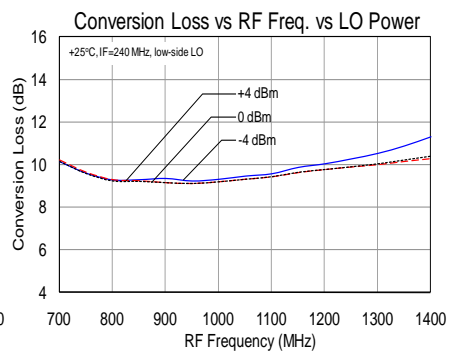
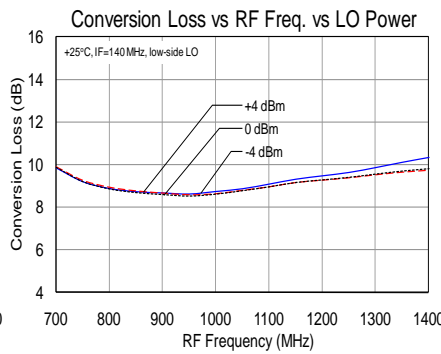
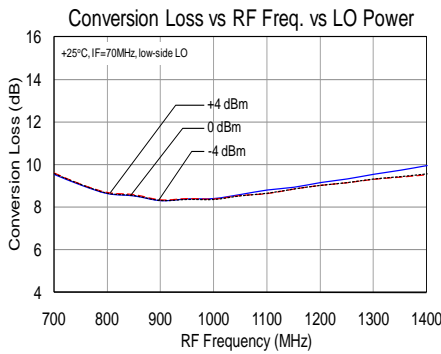
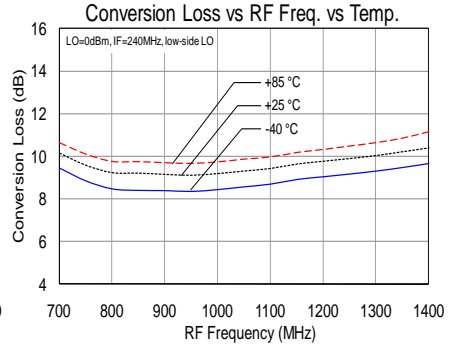
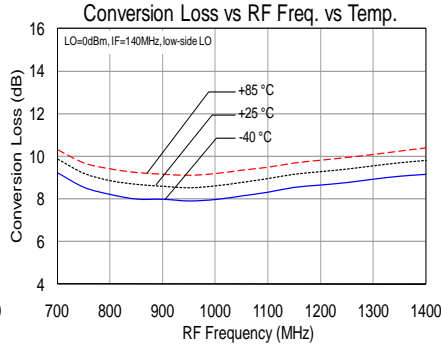
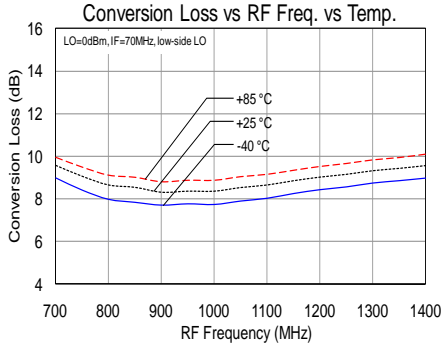

Down Conversion Application Circuit: ML483-PCB

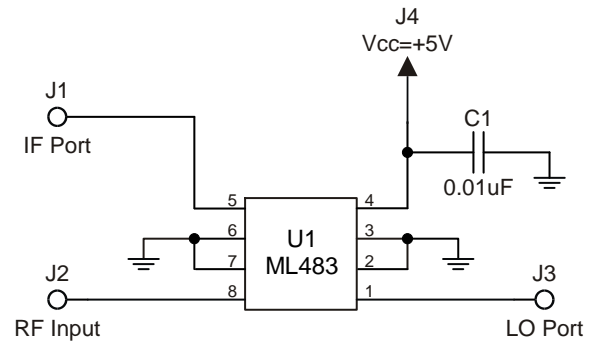
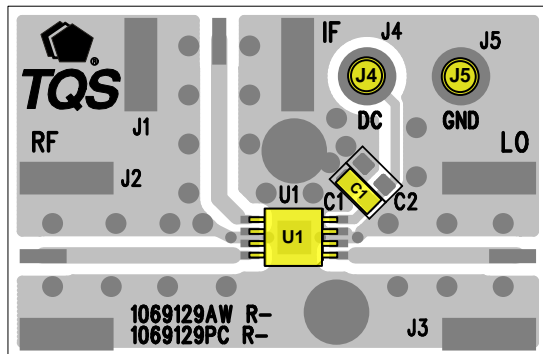

Pin Configuration and Description

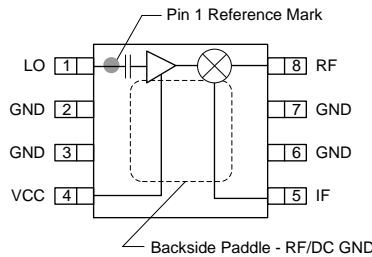

| Pin No. | Symbol | Description |
|-----------------|--------|---|
| 1 | LO | Local Oscillator Injection. Internally DC Blocked |
| 2, 3, 6, 7 | GND | RF/DC Ground |
| 4 | Vcc | Supply voltage. An external bypass capacitor should be used near this pin. |
| 5 | IF | Intermediate Frequency |
| 8 | RF | Radio Frequency |
| Backside Paddle | GND | RF/DC Ground. Follow recommended via pattern and ensure good solder attach for best thermal and electrical performance. |

Evaluation Board PCB Information

Qorvo PCB 1069129 Material and Stack-up

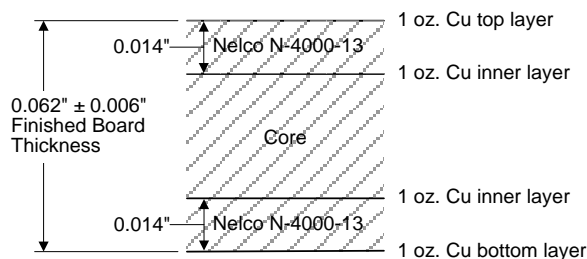

50 ohm line dimensions: width = 0.026", spacing = 0.025"

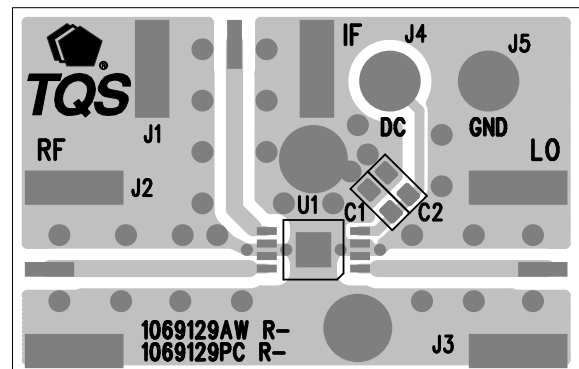

Product Compliance Information

ESD Sensitivity Ratings



Caution! ESD-Sensitive Device

ESD Rating: Class 1A
 Value: ≥ 250 V to < 500 V
 Test: Human Body Model (HBM)
 Standard: ESDA/JEDEC Standard JS-001-2012

ESD Rating: Class C2
 Value: ≥ 500 V to < 1000 V
 Test: Charged Device Model (CDM)
 Standard: JEDEC Standard JESD22-C101F

MSL Rating

MSL Rating: Level 2
 Test: 260 °C convection reflow
 Standard: JEDEC Standard IPC/JEDEC J-STD-020

Solderability

Compatible with both lead-free (260 °C maximum reflow temperature) and tin/lead (245 °C maximum reflow temperature) soldering processes.

Contact plating: Matte Tin

RoHS Compliance

This part is compliant with EU 2002/95/EC RoHS directive (Restrictions on the Use of Certain Hazardous Substances in Electrical and Electronic Equipment).

This product also has the following attributes:

- Lead Free
- Halogen Free (Chlorine, Bromine)
- Antimony Free
- TBBP-A (C₁₅H₁₂Br₄O₂) Free
- PFOS Free
- SVHC Free

Important Notice

For the latest specifications, additional product information, worldwide sales and distribution locations:

Web: www.triquint.com **Tel:** 877-800-8584
Email: customer.support@qorvo.com

For information about the merger of RFMD and TriQuint as Qorvo:

Web: www.qorvo.com

For technical questions and application information:

Email: sjcappliations.engineering@qorvo.com



Contact Information

The information contained herein is believed to be reliable. TriQuint makes no warranties regarding the information contained herein. TriQuint assumes no responsibility or liability whatsoever for any of the information contained herein. TriQuint assumes no responsibility or liability whatsoever for the use of the information contained herein. The information contained herein is provided "AS IS, WHERE IS" and with all faults, and the entire risk associated with such information is entirely with the user. All information contained herein is subject to change without notice. Customers should obtain and verify the latest relevant information before placing orders for TriQuint products. The information contained herein or any use of such information does not grant, explicitly or implicitly, to any party any patent rights, licenses, or any other intellectual property rights, whether with regard to such information itself or anything described by such information.

TriQuint products are not warranted or authorized for use as critical components in medical, life-saving, or life-sustaining applications, or other applications where a failure would reasonably be expected to cause severe personal injury or death.

Looking for pricing, stock, or lifecycle information?

Click below to explore more details on WIN SOURCE:

-  [View ML483-G on WIN SOURCE](#)
-  [RF Micro Devices Information](#)

Optimize Your Supply Chain with WIN SOURCE Solutions

-  Global Sourcing Solution
-  Obsolete Management
-  Cost Control Management
-  Shortage Management
-  Alternative Solution
-  Excess Inventory Management