



**THE DATASHEET OF
ADM8843ACPZ-REEL7**



FEATURES

- Drives 4 LEDs from a 2.6 V to 5.5 V (Li-Ion) input supply
- 1×/1.5×/2× fractional charge pump to maximize power efficiency
- 0.3% typical LED current matching
- Up to 88% power efficiency over Li-Ion range
- Powers main and sub display LEDs with individual shutdown
- Package footprint only 9 mm² (3 mm × 3 mm)
- Package height only 0.75 mm
- Low power shutdown mode
- Shutdown function
- Soft start limiting in-rush current

APPLICATIONS

- Cellular phones with main and sub displays
- White LED backlighting
- Camera flash/strobes and movie light applications
- Micro TFT color displays
- DSC
- PDA's

GENERAL DESCRIPTION

The ADM8843 uses charge pump technology to provide the power to drive up to four LEDs. The LEDs are used for back-lighting a color LCD display that has regulated constant current for uniform brightness intensity. The main display can use up to three LEDs, and the sub display uses one LED. The CTRL1 and CTRL2 digital input control pins control the shutdown operation and the brightness of the main and sub displays.

To maximize power efficiency, the charge pump can operate in 1×, 1.5×, or 2× mode. The charge pump automatically switches among 1×/1.5×/2× modes, based on the input voltage, to maintain sufficient drive for the LED anodes at the highest power efficiency.

Improved brightness matching of the LEDs is achieved by a feedback pin that senses individual LED current with a typical matching accuracy of 0.3%.

FUNCTIONAL BLOCK DIAGRAM

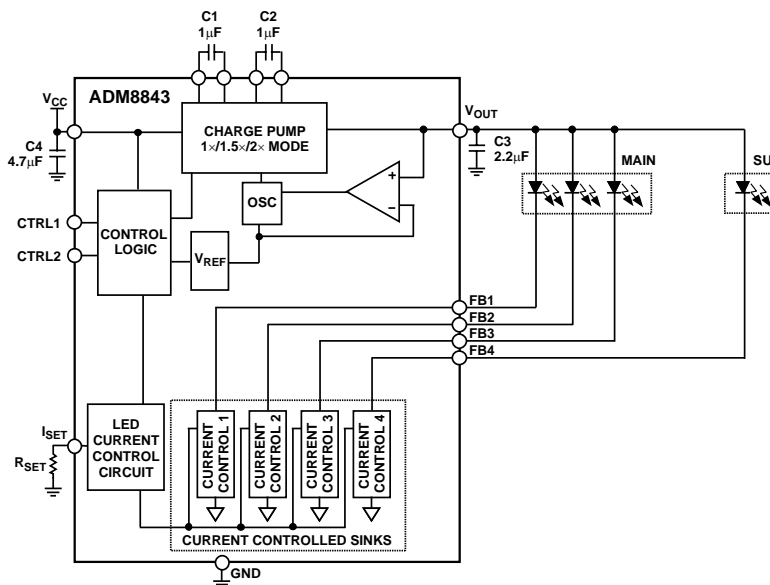

Figure 1.

TABLE OF CONTENTS

Features	1
Applications.....	1
General Description	1
Functional Block Diagram	1
Revision History	2
Specifications.....	3
Absolute Maximum Ratings.....	4
Thermal Resistance	4
ESD Caution.....	4
Pin Configuration and Function Descriptions.....	5
Typical Performance Characteristics	6
Theory of Operation	9
Automatic Gain Control.....	10
Brightness Control with a Digital PWM Signal	10

REVISION HISTORY

7/2018—Rev. D to Rev. E

Change to Features Section	1
Changed Thermal Characteristics Section to Thermal Resistance Section	4
Changes to Thermal Resistance Section.....	4
Added Table 3; Renumbered Sequentially	4
Updated Outline Dimensions	16
Changes to Ordering Guide	16

3/2017—Rev. C to Rev. D

Changed CP-16-3 to CP-16-22	Throughout
Changes to Figure 2.....	5
Updated Outline Dimensions	16
Changes to Ordering Guide	16

1/2011—Rev. B to Rev. C

Changes to Figure 14.....	7
---------------------------	---

LED Brightness Control Using a PWM Signal Applied to V_{PWM}	12
LED Brightness Control Using a DC Voltage Applied to V_{BRIGHT}	12
Applications.....	13
Layout Considerations and Noise	13
White LED Shorting	13
Driving Four LEDs in the Main Display Only	13
Driving Fewer than Four LEDs	13
Using Smaller Capacitor Values	14
Power Efficiency.....	15
Outline Dimensions	16
Ordering Guide	16

4/2010—Rev. A to Rev. B

Removed CP-16-12 Package	Universal
Change to Figure 2	5
Change to Figure 6	6
Changes to Figure 14.....	7
Changes to Figure 15.....	8
Updated Outline Dimensions.....	16
Changes to Ordering Guide	16

12/2006—Rev. 0 to Rev. A

Change to Thermal Characteristics Section	4
Changes to Outline Dimensions	16
Changes to Ordering Guide	16

10/2004—Revision 0: Initial Version

SPECIFICATIONS

$V_{CC} = 2.6\text{ V to }5.5\text{ V}$; $T_A = -40^\circ\text{C to }+85^\circ\text{C}$, unless otherwise noted; $C_1, C_2 = 1.0\ \mu\text{F}$; $C_3 = 2.2\ \mu\text{F}$; $C_4 = 4.7\ \mu\text{F}$.

Table 1.

Parameter	Min	Typ	Max	Unit	Test Conditions
INPUT VOLTAGE, V_{CC}	2.6		5.5	V	
SUPPLY CURRENT, I_{CC}		2.6	5	mA	All four LEDs disabled, $V_{CC} = 3.3\text{ V}$, $R_{SET} = 7.08\text{ k}\Omega$, $CTRL1 = 1$, $CRTL2 = 1$
SHUTDOWN CURRENT			5	μA	
CHARGE PUMP FREQUENCY		1.5		MHz	
CHARGE PUMP MODE THRESHOLDS					
1.5 \times to 2 \times		3.33		V	
2 \times to 1.5 \times		3.36		V	
Hysteresis		40		mV	
1 \times to 1.5 \times		4.77		V	
1.5 \times to 1 \times		4.81		V	
Hysteresis		40		mV	
I_{SET} PIN					
LED : LED Matching		0.3		%	$I_{LED} = 20\text{ mA}$, $V_{FB} = 0.4\text{ V}$
I_{SET} Pin Voltage		1.18		V	
I_{LED} -to- I_{SET} Ratio		120			
I_{LED} -to- I_{SET} Ratio Accuracy		$\pm 5\%$			
MIN COMPLIANCE ON FBx PIN		0.15		V	$I_{SET} = 15\text{ mA}$
CHARGE PUMP OUTPUT RESISTANCE		1.2		Ω	1 \times mode
		3.5		Ω	1.5 \times mode
		8.0		Ω	2 \times mode
LED CURRENT			20	mA	
PWM ¹	0.1		200	kHz	
DIGITAL INPUTS					
Input High	0.7 V_{CC}		V		
Input Low			0.3 V_{CC}	V	
Input Leakage Current			1	μA	
CHARGE PUMP POWER EFFICIENCY		88		%	$CTRL1 = 1$, $CRTL2 = 1$, $V_{CC} = 3.4\text{ V}$, $V_{FB} = 0.2\text{ V}$, $I_{FB} = 20\text{ mA}$
V_{OUT} RIPPLE		30		mV	$V_{CC} = 3.6\text{ V}$, $I_{LED} = 20\text{ mA}$, all four LEDs enabled

¹ Guaranteed by design. Not 100% production tested.

ABSOLUTE MAXIMUM RATINGS

$T_A = 25^\circ\text{C}$, unless otherwise noted.

Table 2.

Parameter	Rating
Supply Voltage, V_{CC}	-0.3 V to +6.0 V
I_{SET}	-0.3 V to +2.0 V
CTRL1, CTRL2	-0.3 V to +6.0 V
V_{OUT} Shorted ¹	Indefinite
Feedback Pins FB1 to FB4	-0.3 V to +6.0 V
Operating Temperature Range	-40°C to +85°C
V_{OUT} ²	180 mA
Storage Temperature Range	-65°C to +125°C
Power Dissipation	2 mW
ESD Class	1

¹ Short through LED.

² Based on long-term current density limitations.

Stresses at or above those listed under Absolute Maximum Ratings may cause permanent damage to the product. This is a stress rating only; functional operation of the product at these or any other conditions above those indicated in the operational section of this specification is not implied. Operation beyond the maximum operating conditions for extended periods may affect product reliability.

THERMAL RESISTANCE

Thermal resistance values specified in Table 3 are simulated based on JEDEC specifications, unless specified otherwise, and must be used in compliance with JESD51-12.

Table 3. Thermal Resistance

Package Type	θ_{JA}	θ_{JC} ¹	θ_{JB}	Ψ_{JT}	Ψ_{JB}	Unit
CP-16-27 ²	39.25	7.5	17.4	0.8	12.4	°C/W

¹ For θ_{JC} , 100 μm thermal interface material is used. Thermal interface material is assumed to have 3.6 W/mK.

² Using enhanced heat removal (printed circuit board (PCB), heat sink, and airflow) techniques improves thermal resistance values.

ESD CAUTION



ESD (electrostatic discharge) sensitive device. Charged devices and circuit boards can discharge without detection. Although this product features patented or proprietary protection circuitry, damage may occur on devices subjected to high energy ESD. Therefore, proper ESD precautions should be taken to avoid performance degradation or loss of functionality.

PIN CONFIGURATION AND FUNCTION DESCRIPTIONS

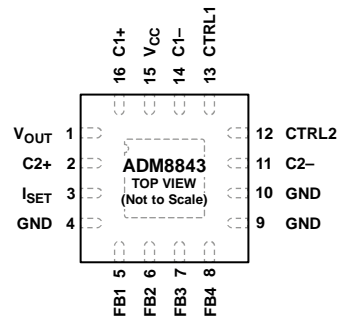

NOTES
1. CONNECT THE EXPOSED PADDLE TO GND.

05050-003

Figure 2. Pin Configuration

Table 4. Pin Function Descriptions

Pin No.	Mnemonic	Description
1	V _{OUT}	Charge Pump Output. A 2.2 μ F capacitor to ground is required on this pin. Connect V _{OUT} to the anodes of all the LEDs.
2	C2+	Flying Capacitor 2 Positive Connection.
3	I _{SET}	Bias Current Set Input. The current flowing through the R _{SET} resistor, I _{SET} , is gained up by 120 to provide the I _{LED} current. Connect a resistor, R _{SET} , to GND to set the bias current as V _{SET} /R _{SET} . Note that V _{SET} = 1.18 V.
4, 9, 10	GND	Device Ground Pins.
5 to 8	FB1 to FB4	LED1 to LED4 Cathode Connection and Charge Pump Feedback. The current flowing in these LEDs is 120 times the current flowing through R _{SET} , I _{SET} . When using fewer than four LEDs, this pin can be left unconnected or connected to GND.
11	C2-	Flying Capacitor 2 Negative Connection.
12	CTRL2	Digital Input. 3 V CMOS Logic. Used with CTRL1 to control the shutdown operation of the main and sub LEDs.
13	CTRL1	Digital Input. 3 V CMOS Logic. Used with CTRL2 to control the shutdown operation of the main and sub LEDs.
14	C1-	Flying Capacitor 1 Negative Connection.
15	V _{CC}	Positive Supply Voltage Input. Connect this pin to a 2.6 V to 5.5 V supply with a 4.7 μ F decoupling capacitor.
16	C1+	Flying Capacitor 1 Positive Connection.
-	EP	Expose Paddle. Connect the exposed paddle to GND.

TYPICAL PERFORMANCE CHARACTERISTICS

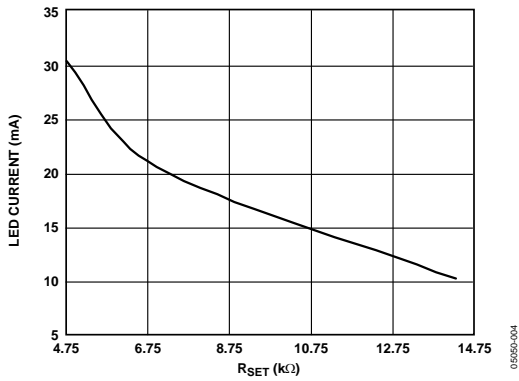

Figure 3. I_{LED} (mA) vs. R_{SET}

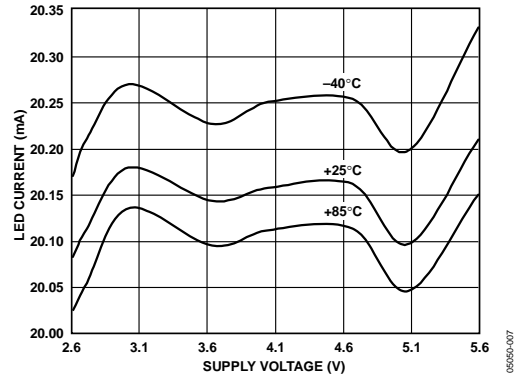

Figure 6. I_{LED} (mA) vs. Temperature (°C), Four LEDs Enabled

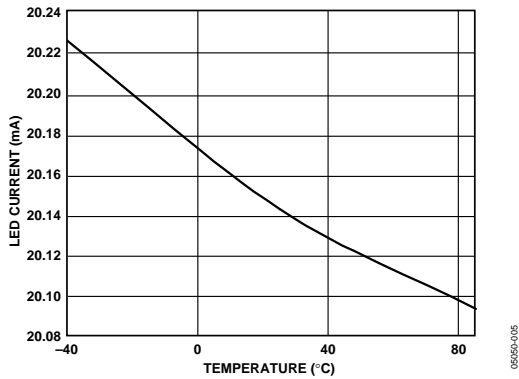

Figure 4. I_{LED} (mA) Variation over Temperature (°C), $V_{CC} = 3.6$ V

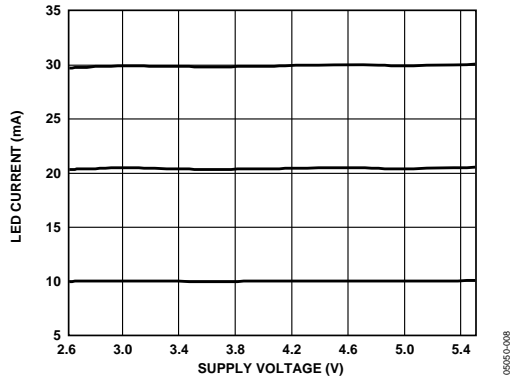

Figure 7. I_{LED} (mA) vs. Supply Voltage (V)

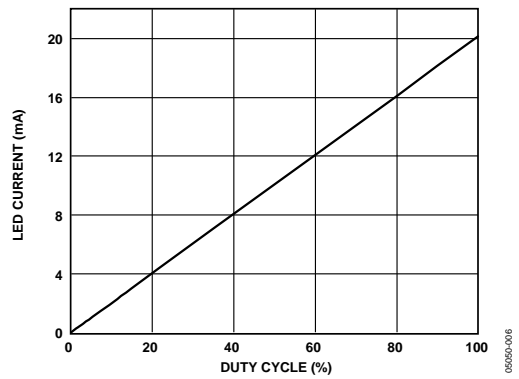

Figure 5. I_{LED} (mA) vs. PWM Dimming (Varying Duty Cycle), Four LEDs Enabled, Frequency = 1 kHz

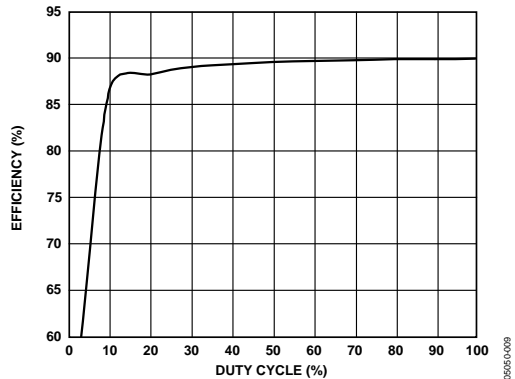

Figure 8. LED Efficiency vs. Varying Duty Cycle of 1 kHz PWM Signal, Four LEDs Enabled, 20 mA/LED

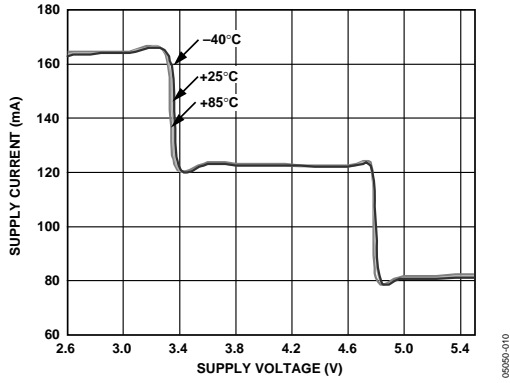

Figure 9. Supply Current vs. Supply Voltage over Temperature, Four LEDs Enabled @ 20 mA/LED

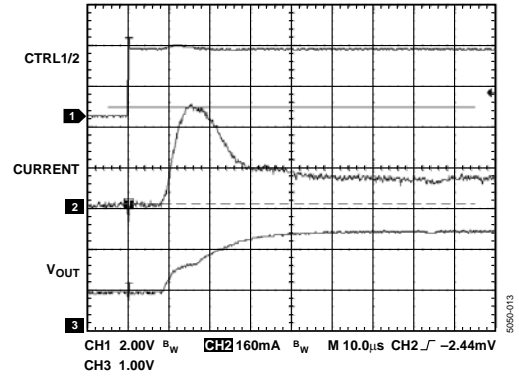

Figure 12. Soft Start Showing the Initial In-Rush Current and V_{OUT} Variation, Four LEDs @ 20 mA/LED, $V_{CC} = 3.6$ V

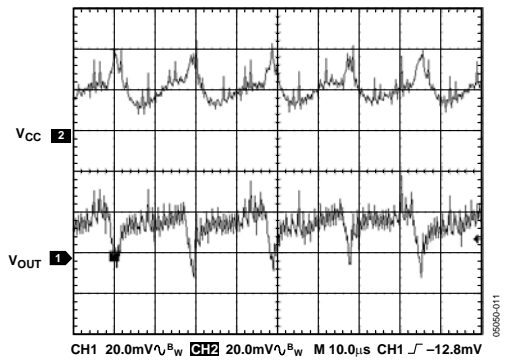

Figure 10. 1.5x Mode Operating Waveforms

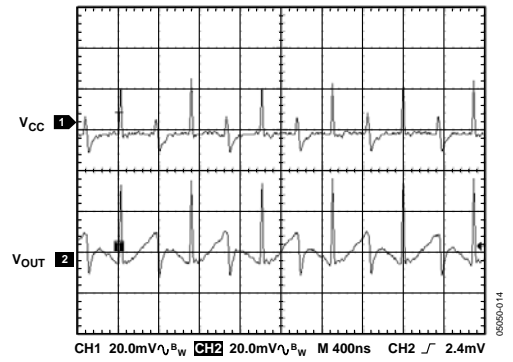

Figure 13. 2x Mode Operating Waveforms

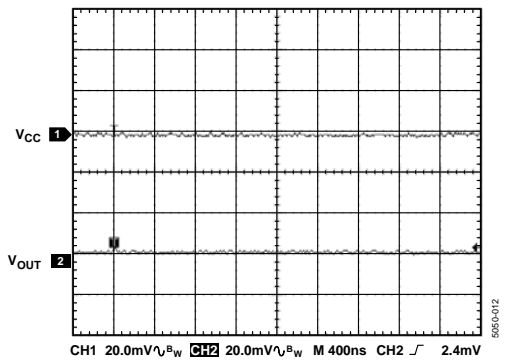

Figure 11. 1x Mode Operating Waveforms

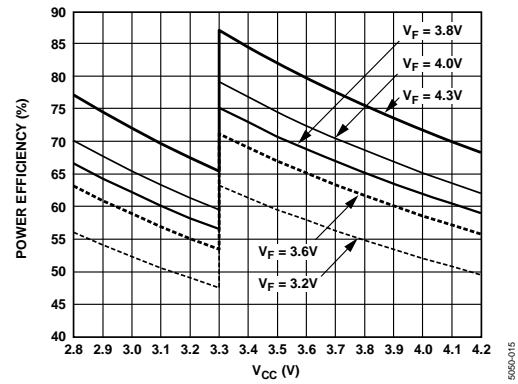

Figure 14. Power Efficiency vs. Supply Voltage over Li-Ion Range, Four LEDs @ 20 mA/LED

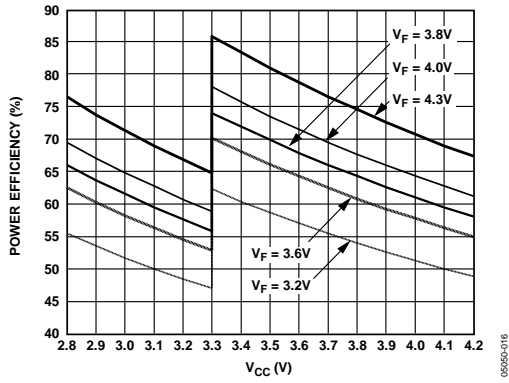

Figure 15. Power Efficiency vs. Supply Voltage over Li-Ion Range, Four LEDs @ 15 mA/LED

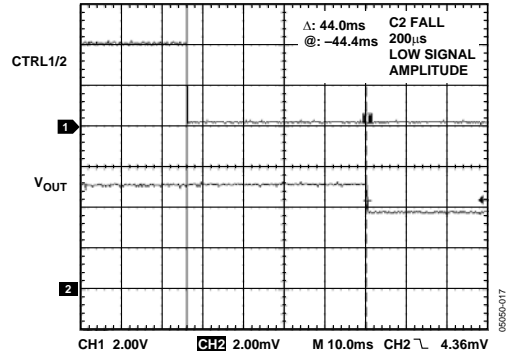

Figure 16. TPC Delay

THEORY OF OPERATION

The ADM8843 charge pump driver for LCD white LED backlights implements a multiple-gain charge pump (1×, 1.5×, 2×) to maintain the correct voltage on the anodes of the LEDs over a 2.6 V to 5.5 V (Li-Ion) input supply voltage. The charge pump automatically switches among 1×/1.5×/2× modes, based on the input voltage, to maintain sufficient drive for the LED anodes, with V_{CC} input voltages as low as 2.6 V. It also includes regulation of the charge pump output voltage for supply voltages up to 5.5 V. The ADM8843's four LEDs are arranged into two groups, main and sub. The main display can have up to three LEDs (FB1 to FB3), and the sub display has one LED (FB4) (see Figure 18). The CTRL1 and CTRL2 digital input control pins control the shutdown operation and the brightness of the main and sub displays (see Table 5).

Table 5. Shutdown Truth Table

CTRL1	CTRL2	LED Shutdown Operation
0	0	Sub display off/main display off
0	1	Sub display off/main display on
1	0	Sub display on/main display off
1	1	Sub display on/main display on

An external resistor, R_{SET}, is connected between the I_{SET} pin and GND. This resistor sets up a reference current, I_{SET}, which is internally gained up by 120 within the ADM8843 to produce I_{LED} currents of up to 20 mA/LED (I_{LED} = I_{SET} × 120 and I_{SET} = 1.18 V/R_{SET}). The ADM8843 uses four separate current sinks to sense each LED current individually with a typical matching performance of 0.3%. This current matching performance ensures uniform brightness across a color display.

The ADM8843 lets the user control the brightness of the white LEDs with a digital PWM signal applied to CTRL1 and/or CTRL2. The duty cycle of the applied PWM signal determines the brightness of the main and/or sub display backlight white LEDs. The ADM8843 also allows the brightness of the white LEDs to be controlled using a dc voltage (see Figure 17). Soft start circuitry limits the in-rush current flow at power-up. The ADM8843 is fabricated using CMOS technology for minimal power consumption and is packaged in a 16-lead lead frame chip scale package.

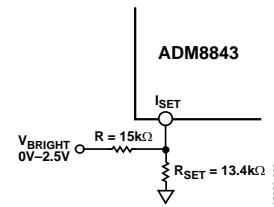

Figure 17. PWM Brightness Control Using a DC Voltage Applied to V_{BRIGHT}

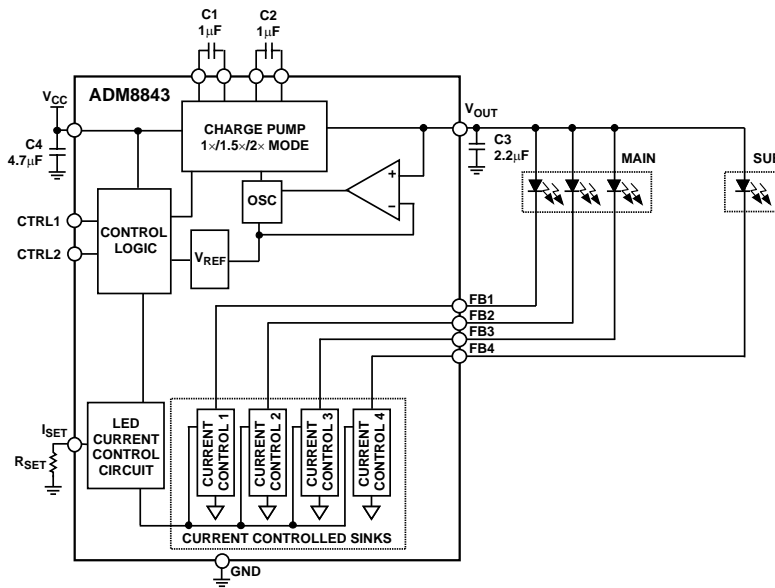

Figure 18. Functional Block Diagram

AUTOMATIC GAIN CONTROL

The automatic gain control block controls the operation of the charge pump by selecting the appropriate gain for the charge pump. Doing so maintains sufficient drive for the LED anodes at the highest power efficiency over a 2.6 V to 5.5 V input supply range. The charge pump switching thresholds are described in Table 6.

Table 6. Charge Pump Switching Thresholds

Gain	Threshold (V)
1.5× to 2×	3.33
2× to 1.5×	3.36
1× to 1.5×	4.77
1.5× to 1×	4.81

BRIGHTNESS CONTROL WITH A DIGITAL PWM SIGNAL

PWM brightness control provides the widest brightness control method by pulsing the white LEDs on and off using one or both digital input control pins, CTRL1 and CTRL2. PWM brightness control also removes any chromaticity shifts associated with changing the white LED current, because the LEDs operate at either zero current or full current (set by R_{SET}).

The digital PWM signal applied with a frequency of 100 Hz to 200 kHz turns the current control sinks on and off using CTRL1 and/or CTRL2. The average current through the LEDs changes with the PWM signal duty cycle. If the PWM frequency is much less than 100 Hz, flicker may be seen in the LEDs. For the ADM8843, zero duty cycle turns off the LEDs, and a 50% duty cycle results in an average LED current, I_{LED} , that is half the programmed LED current. For example, if R_{SET} is set to program 20 mA/LED, a 50% duty cycle results in an average I_{LED} of 10 mA/LED, which is half the programmed LED current.

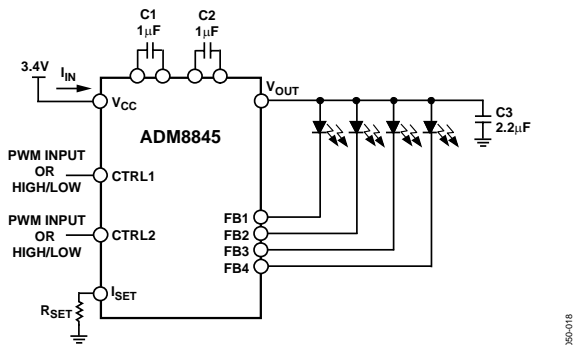

Figure 19. Digital PWM Brightness Control Application Diagram

Applying a digital PWM signal to one or both digital input control pins, CTRL1 and CTRL2, adjusts the brightness of the sub and/or main displays. The ADM8843's four white LEDs are organized into two groups, main display (FB1 to FB3) and sub display (FB4); refer to the Theory of Operation section.

The brightness of the ADM8843's main and sub displays can be controlled together or separately. This is achieved by applying a digital PWM signal to both the CTRL1 and CTRL2 pins. The duty cycle of the applied digital PWM signal determines the brightness of the main and sub displays together. Varying the duty cycle of the applied PWM signal varies the brightness of the main and sub displays from 0% to 100%.

By holding CTRL1 low and applying a digital PWM signal to CTRL2, the sub display is turned off and the main display is turned on. Then the brightness of the main display is determined by the duty cycle of the applied digital PWM signal.

By applying a digital PWM signal to CTRL1 and holding CTRL2 low, the sub display is turned on and the main display is turned off. Then the brightness of the sub display is determined by the duty cycle of the applied digital PWM signal.

By applying a digital PWM signal to CTRL1 and holding CTRL2 high, the sub display is turned on and the main display is turned on. Then the brightness of the sub display is determined by the duty cycle of the applied digital PWM signal. The brightness of the main display is set to the maximum (maximum is set by R_{SET}).

By holding CTRL1 high and applying a digital PWM signal to CTRL2, the sub and main displays are turned on. Then the brightness of the main display is determined by the duty cycle of the applied digital PWM signal. The brightness of the sub display is set to the maximum (maximum is set by R_{SET}).

When CTRL1 and CTRL2 are low, the LED current control sinks shutdown. Shutdown of the charge pump is delayed by 15 ms. This timeout period, t_{CP} , allows the ADM8843 to determine if a digital PWM signal is present on CTRL1 and CTRL2, or if the user has selected a full chip shutdown (see Figure 20).

If digital PWM brightness control of the LEDs is not required, a constant Logic Level 1 (V_{CC}) or Logic Level 0 (GND) must be applied.

The four white LED in the ADM8843 are arranged into two groups, sub and main. It is possible to configure the four LEDs as in Table 7. Refer also to Figure 20.

Table 7. Digital Inputs Truth Table

CTRL1	CTRL2	LED Operation
0	0	Sub display off/main display off (full shutdown) ^{1,2}
0	1	Sub display off/main display on ^{1,3}
1	0	Sub display on/main display off ^{1,2}
1	1	Sub display on/main display on (full on) ^{1,3}
0	PWM	Sub display off/digital PWM brightness control on main display ^{4,5}
PWM	0	Digital PWM brightness control on sub display/main display off ^{2,4}
1	PWM	Sub display on/digital PWM brightness control on main display ^{1,5}
PWM	1	Digital PWM brightness control on sub display/main display on ⁵
PWM	PWM	Digital PWM brightness control on sub and main display ⁵

¹ Sub display on means the display is on with the maximum brightness set by the R_{SET} resistor. CTRL1 = 1 means a constant logic level (V_{CC}) is applied to CTRL1.

² Main display off means only the main display is off. CTRL2 = 0 means a constant logic level (GND) is applied to CTRL2.

³ Main display on means the display is on with the maximum brightness set by the R_{SET} resistor. CTRL2 = 1 means a constant logic level (V_{CC}) is applied to CTRL2.

⁴ Sub display off means only the sub display LEDs is off. CTRL1 = 0 means a constant logic level (GND) is applied to CTRL1.

⁵ PWM means a digital PWM signal is applied to the CTRL1 and/or the CTRL2 pin with a frequency from 100 Hz to 200 kHz.

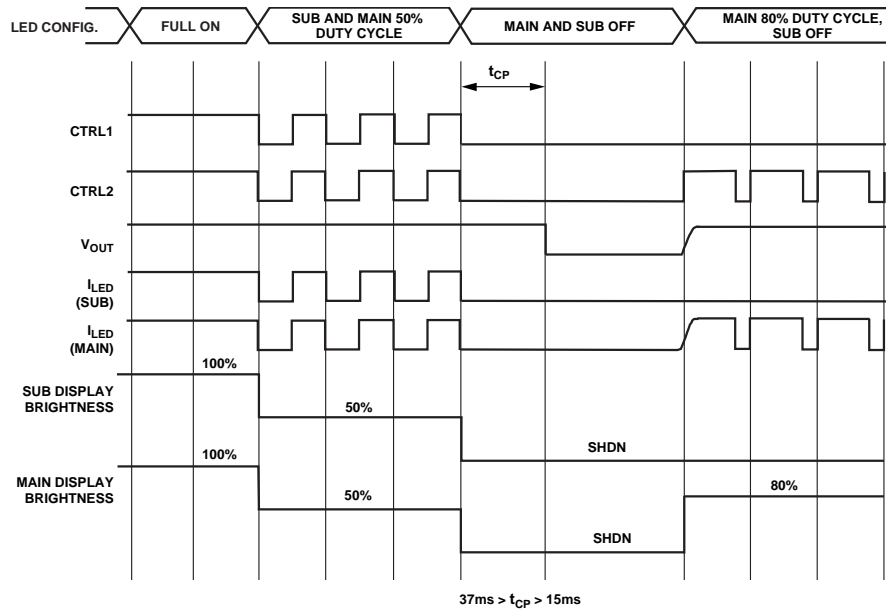

Figure 20. Application Timing

LED BRIGHTNESS CONTROL USING A PWM SIGNAL APPLIED TO V_{PWM}

Adding two external resistors and a capacitor, as shown in Figure 21, can also be used for PWM brightness control. This PWM brightness control method can be used instead of CTRL1 and/or CTRL2 digital PWM brightness control. With this configuration, CTRL1 and CTRL2 digital logic pins can control shutdown of the white LEDs, and V_{PWM} can control the brightness of all the white LEDs. This is done by applying a high frequency PWM signal (amplitude 0 V to 2.5 V) to drive an R-C-R filter on the I_{SET} pin of the ADM8843. A 0% PWM duty cycle corresponds to 20 mA/LED, and a 100% PWM duty cycle corresponds to a 0 mA/LED. At PWM frequencies above 5 kHz, C5 may be reduced (see Figure 21). The amplitude of the PWM signal must only be 0 V and 2.5 V to result in 20 mA flowing in each LED.

$$I_{LED} = \frac{I_{SET} - Voltage}{\frac{R_{SET} \times 2R}{R_{SET} + 2R}} \times 120 \times \frac{(1 - Duty Cycle)}{100}$$

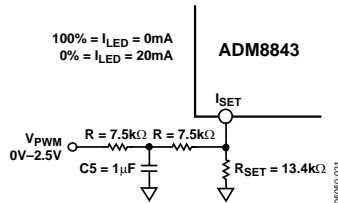

Figure 21. PWM Brightness Control Using Filter-PWM Signal

LED BRIGHTNESS CONTROL USING A DC VOLTAGE APPLIED TO V_{BRIGHT}

By adding one resistor, as shown in Figure 17, this configuration can also be used for brightness control of the white LEDs by using a dc voltage applied to the V_{BRIGHT} node. Figure 22 shows an application example of LED brightness control using a dc voltage with an amplitude of 0 V to 2.5 V applied to V_{BRIGHT}.

The equation for I_{LED} is

$$I_{SET} = [(1/R_{SET} + 1/R)(V_{SET})] - [(1/R)(V_{BRIGHT})]$$

$$I_{LED} = 120 \times I_{SET}$$

where:

R = 15 kΩ

V_{SET} = voltage at I_{SET} pin (1.18 V)

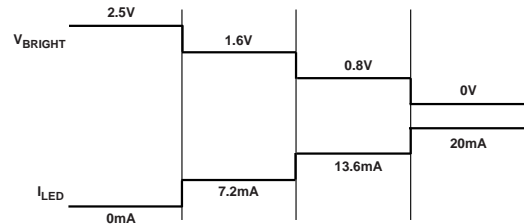

Figure 22. PWM Brightness Control Application Diagram Using a DC Voltage Applied to V_{BRIGHT}

APPLICATIONS

LAYOUT CONSIDERATIONS AND NOISE

Because of the ADM8843's switching behavior, PCB trace layout is an important consideration. To ensure optimum performance, a ground plane should be used, and all capacitors (C1, C2, C3, C4) must be located with minimal track lengths to the pins of the ADM8843.

WHITE LED SHORTING

If an LED is shorted, the ADM8843 continues to drive the remaining LEDs with I_{LED} per LED ($I_{LED} = I_{SET} \times 120 \text{ mA}$). This is because the ADM8843 uses four internal current sinks to produce the LED current. If an LED is shorted, the ADM8843 continues to sink ($I_{SET} \times 120 \text{ mA}$).

DRIVING FOUR LEDs IN THE MAIN DISPLAY ONLY

The ADM8843 can be operated with four LEDs in the main display only (see Figure 23). With this configuration, CTRL1 and CTRL2 are used together to control the main display shutdown operation and brightness control.

DRIVING FEWER THAN FOUR LEDs

The ADM8843 can be operated with fewer than four LEDs in parallel by simply leaving the unused FBx pins floating or by connecting them to GND. For example, Figure 24 shows three LEDs being powered by the ADM8843.

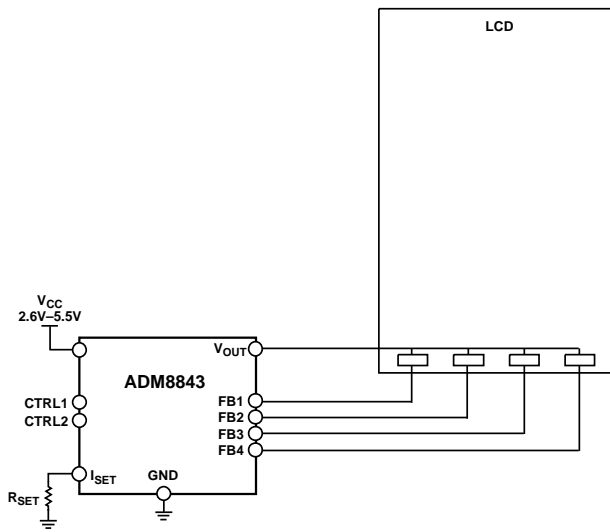

Figure 23. Driving Four White LEDs

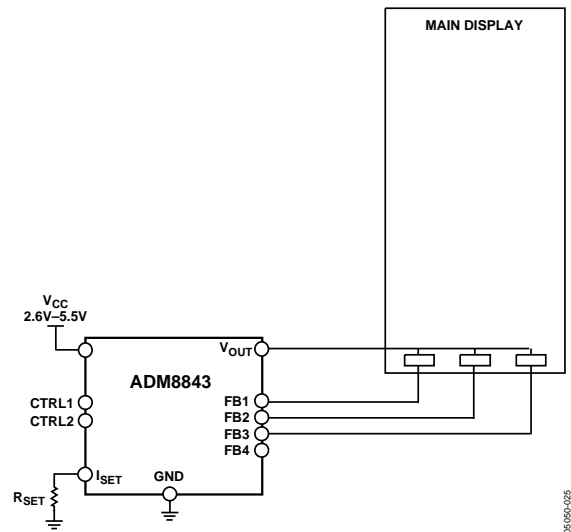

Figure 24. Driving Three White LEDs

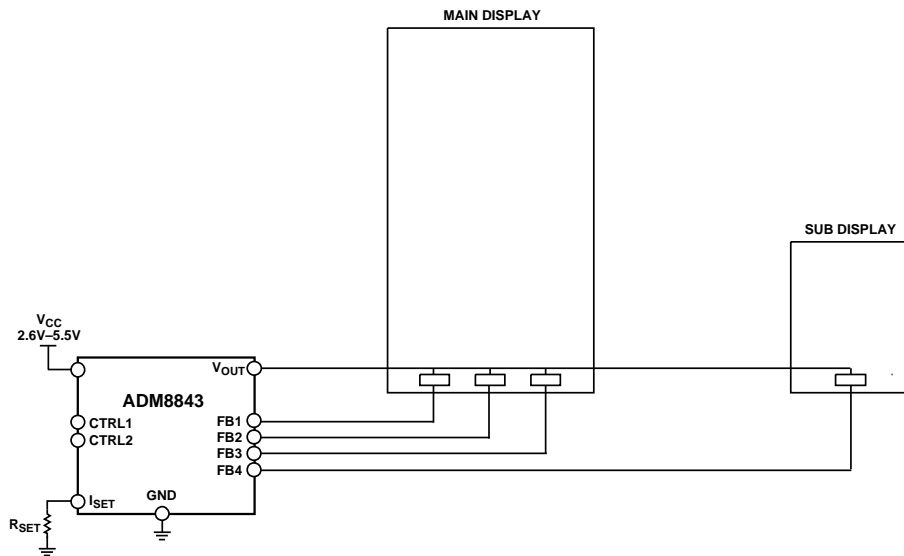

Figure 25. Typical Application Diagram

USING SMALLER CAPACITOR VALUES

The ADM8843 can be operated with the smaller capacitor values described here to reduce capacitor footprint sizes.

Option 1

Input and output ripple plots for 1× and 1.5× modes of operation are shown with C1, C2 = 0.22 μF; C3 = 0.47 μF; and C4 = 1 μF.

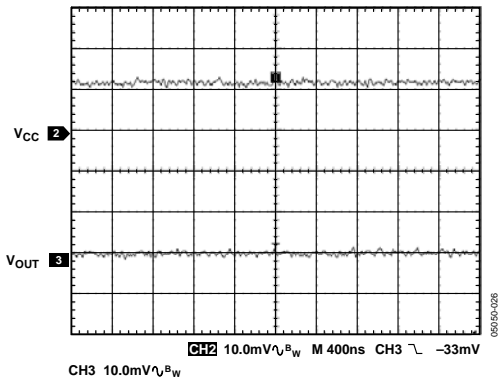

Figure 26. 1× Mode Operation, Four LEDs with 20 mA/LED at V_{CC} = 5.0 V, with a 1 μF V_{CC} Decoupling Capacitor

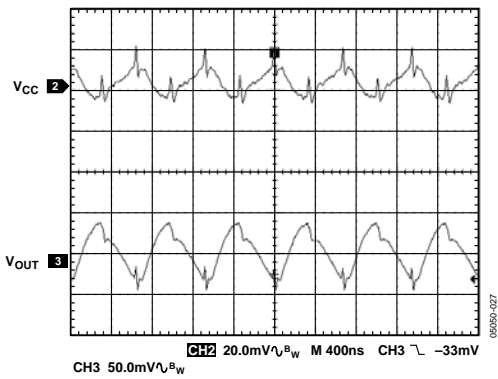

Figure 27. 1.5× Mode Operation, Four LEDs with 20 mA/LED at V_{CC} = 3.6 V, with a 1 μF V_{CC} Decoupling Capacitor

Option 2

Input and output ripple plots for 1× and 1.5× modes of operation are shown with C1, C2 = 0.22 μF; C3 = 0.47 μF; and C4 = 4.7 μF.

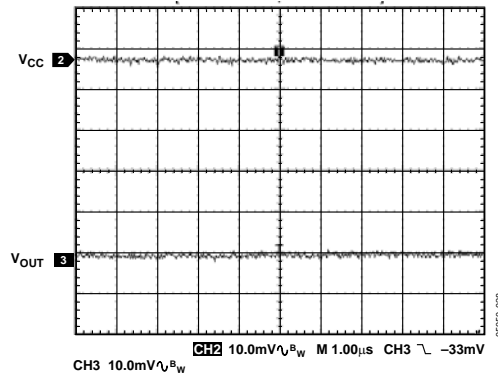

Figure 28. 1× Mode Operation, Four LEDs with 20 mA/LED at V_{CC} = 5.0 V, with a 4.7 μF V_{CC} Decoupling Capacitor

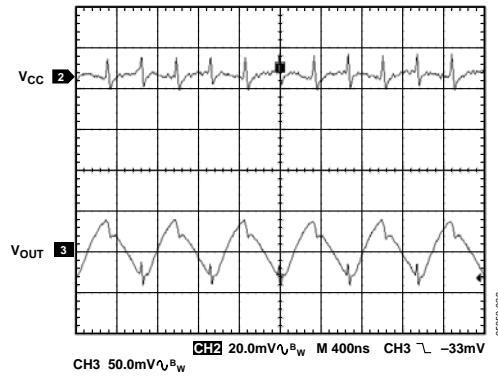

Figure 29. 1.5× Mode Operation, Four LEDs with 20 mA/LED at V_{CC} = 3.6 V, with a 4.7 μF V_{CC} Decoupling Capacitor

POWER EFFICIENCY

The ADM8843 power efficiency (η) equations are as follows:

$$\eta = P_{OUT}/P_{IN}$$

$$P_{IN} = ((V_{CC} \times I_{LOAD} \times Gain) + (I_Q \times V_{CC}))$$

$$P_{OUT} = 4 \times (V_F \times I_{LED})$$

where:

I_Q is the quiescent current of the ADM8843, 2.6 mA.

V_F is the LED forward voltage.

Gain is the charge pump mode (1x, 1.5x, 2x).

Example 1

The ADM8843 driving four white LED with 20 mA/LED at $V_{CC} = 3.4$ V (1.5x mode), LED $V_F = 4.5$ V.

$$P_{IN} = ((V_{CC} \times I_{LOAD} \times Gain) + (V_{CC} \times I_Q))$$

$$P_{IN} = ((3.4 \times 80 \text{ mA} \times 1.5) + (3.4 \times 2.6 \text{ mA}))$$

$$P_{IN} = ((0.408) + (0.00884))$$

$$P_{IN} = 0.41684$$

$$P_{OUT} = 4(V_F \times I_{LED})$$

$$P_{OUT} = 4(4.5 \text{ V} \times 20 \text{ mA})$$

$$P_{OUT} = 0.36$$

$$\eta = P_{OUT}/P_{IN}$$

$$\eta = 0.36/0.41684$$

$$\eta = 87 \%$$

Example 2

The ADM8843 driving four white LED with 20 mA/LED at $V_{CC} = 3.4$ (1.5x mode), LED $V_F = 3.6$ V.

$$P_{IN} = ((V_{CC} \times I_{LOAD} \times Gain) + (V_{CC} \times I_Q))$$

$$P_{IN} = ((3.4 \times 80 \text{ mA} \times 1.5) + (3.4 \times 2.6 \text{ mA}))$$

$$P_{IN} = ((0.408) + (0.00884))$$

$$P_{IN} = 0.41684$$

$$P_{OUT} = 4(V_F \times I_{LED})$$

$$P_{OUT} = 4(3.6 \text{ V} \times 20 \text{ mA})$$

$$P_{OUT} = 0.288$$

$$\eta = P_{OUT}/P_{IN}$$

$$\eta = 0.288/0.41684$$

$$\eta = 70 \%$$

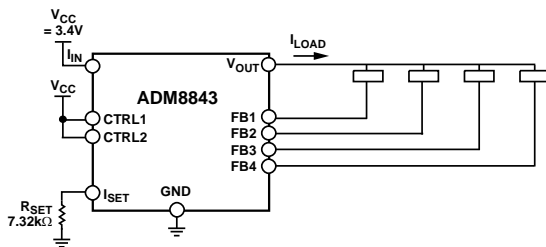
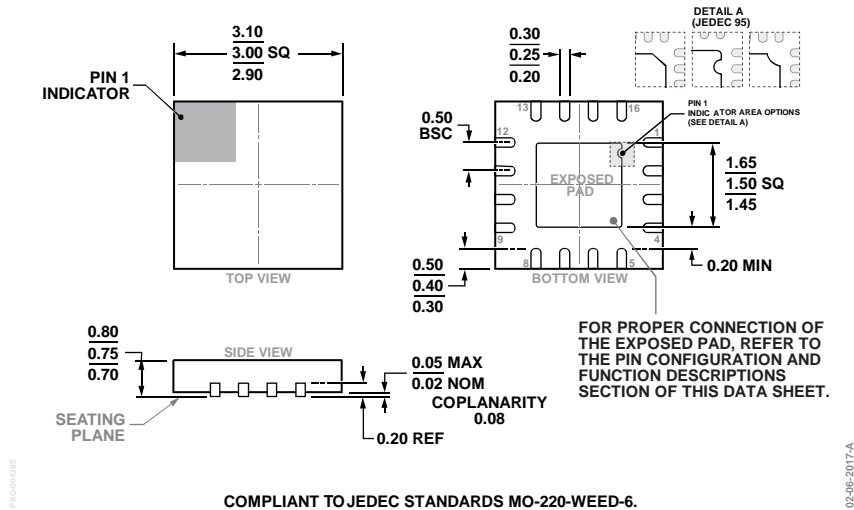

Figure 30. Charge Pump Power Efficiency Diagram, Example 1

06550-019

OUTLINE DIMENSIONS



COMPLIANT TO JEDEC STANDARDS MO-220-WEED-6.

Figure 31. 16-Lead Lead Frame Chip Scale Package [LFCSP]
 3 mm x 3 mm Body and 0.75 mm Package Height
 (CP-16-27)
 Dimensions shown in millimeters

ORDERING GUIDE

Model ¹	Temperature Range	Package Description	Package Option	Marking Code
ADM8843ACPZ-REEL7	-40°C to +85°C	16-Lead Lead Frame Chip Scale Package [LFCSP]	CP-16-27	M2U
ADM8843EB-EVALZ		Evaluation Board		

¹ Z = RoHS Compliant Part.

Looking for pricing, stock, or lifecycle information?

Click below to explore more details on WIN SOURCE:

 [View ADM8843ACPZ-REEL7 on WIN SOURCE](#)

 [Analog Devices Inc. Information](#)

Optimize Your Supply Chain with WIN SOURCE Solutions

-  Global Sourcing Solution
-  Obsolete Management
-  Cost Control Management
-  Shortage Management
-  Alternative Solution
-  Excess Inventory Management