



**THE DATASHEET OF
ADM809ZARTZ-REEL7**



FEATURES

Specified over temperature
 Low power consumption: 17 μA
 Precision voltage monitor: 2.5 V, 3 V, 3.3 V, 5 V options
 Reset assertion down to 1 V V_{CC}
 140 ms minimum power-on reset
 Open-drain $\overline{\text{RESET}}$ output (ADM803)
 Push-pull $\overline{\text{RESET}}$ output (ADM809)
 Push-pull RESET output (ADM810)
 SC70 and SOT-23 packages

APPLICATIONS

Microprocessor systems
 Computers
 Controllers
 Intelligent instruments

FUNCTIONAL BLOCK DIAGRAMS

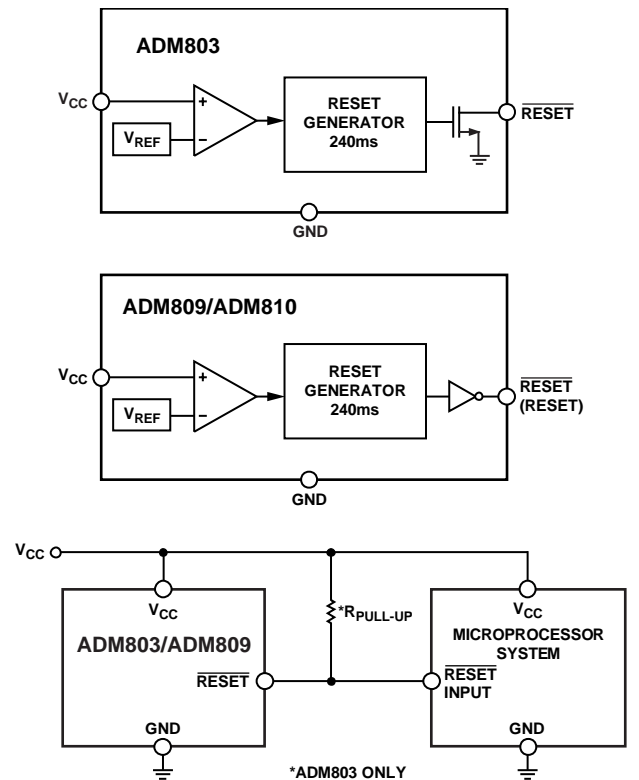

Figure 1.

GENERAL DESCRIPTION

The ADM803/ADM809/ADM810 supervisory circuits monitor the power supply voltage in microprocessor systems. They provide a reset output during power-up, power-down, and brownout conditions. On power-up, an internal timer holds reset asserted for 240 ms. This holds the microprocessor in a reset state until conditions have stabilized. The reset output remains operational with V_{CC} as low as 1 V. The ADM803 and ADM809 provide an active low reset signal ($\overline{\text{RESET}}$), whereas the ADM810 provides an active high signal (RESET) output. The ADM809 and ADM810 have push-pull outputs, whereas the ADM803 has an open-drain output, which requires an external pull-up resistor.

Seven reset threshold voltage options are available, suitable for monitoring a variety of supply voltages (see Table 3).

The reset comparator features built-in glitch immunity, making it immune to fast transients on V_{CC} .

The ADM803/ADM809/ADM810 consume only 17 μA , making them suitable for low power, portable equipment. The ADM803 is available in a 3-lead SC70; the ADM809/ADM810 are available in 3-lead SOT-23 and 3-lead SC70 packages.

TABLE OF CONTENTS

Features	1
Applications.....	1
Functional Block Diagrams.....	1
General Description	1
Revision History	2
Specifications.....	3
Absolute Maximum Ratings.....	4
ESD Caution.....	4

REVISION HISTORY

10/14—Rev. H to Rev. I

Changes to Applications Section	1
Changes to Table 2.....	4
Updated Outline Dimensions	9
Changes to Ordering Guide	10

8/08—Rev. G to Rev. H

Added Figure 4; Renumbered Sequentially	5
Changes to Figure 8.....	6
Updated Outline Dimensions	9
Changes to Ordering Guide	10

9/06—Rev. F to Rev. G

Updated Outline Dimensions	9
Changes to Ordering Guide	9

6/05—Rev. E to Rev. F

Changes to Ordering Guide	4
Updated Outline Dimensions	9

2/05—Rev. D to Rev. E

Changes to Ordering Guide	4
---------------------------------	---

2/05—Rev. C to Rev. D

Changes to Ordering Guide	4
Updated Outline Dimensions	8

Pin Configurations and Function Descriptions	5
Typical Performance Characteristics	6
Interfacing to Other Devices.....	8
Ensuring a Valid Reset Output Down to $V_{CC} = 0\text{ V}$	8
Benefits of an Accurate Reset Threshold	8
Interfacing to Microprocessors with Multiple Interrupts	8
Outline Dimensions	9
Ordering Guide	10

5/03—Rev. B to Rev. C

Added ADM803	Universal
Changes to Features	1
Changes to General Description	1
Changes to Figure 1.....	1
Changes to Specifications.....	2
Changes to Table I	3
Updated Ordering Guide	4

1/03—Rev. A to Rev. B

Changes to Specifications.....	2
Changes to Table I	3
Changes to Ordering Guide	4
Changes to TPCs 1–3, and TPC 7	5
Updated Outline Dimensions	7

10/02—Rev. 0 to Rev. A

Addition of SC70 package	Universal
Change to General Description	1
Changes to Specifications.....	2
Changes to Absolute Maximum Ratings.....	3
Change to Table I.....	3
Change to Ordering Guide.....	4
Change to TPC 1	5
Updated Outline Dimensions	7

4/97—Revision 0: Initial Version

SPECIFICATIONS

V_{CC} = full operating range, $T_A = T_{MIN}$ to T_{MAX} , V_{CC} typical = 5 V for L/M/J models, 3.3 V for T/S models, 3 V for R models, and 2.5 V for Z models, unless otherwise noted.

Table 1.

Parameter	Min	Typ	Max	Unit	Test Conditions/Comments
V_{CC} OPERATING VOLTAGE RANGE	1.0		5.5	V	$T_A = 0^\circ\text{C}$ to 70°C
Supply Current	1.2		5.5	V	$T_A = -40^\circ\text{C}$ to $+125^\circ\text{C}$
		24	35	μA	$V_{CC} < 5.5\text{ V}$, ADM8xxL/M/J, $T_A = -40^\circ\text{C}$ to $+85^\circ\text{C}$
		17	30	μA	$V_{CC} < 3.6\text{ V}$, ADM8xxR/S/T/Z, $T_A = -40^\circ\text{C}$ to $+85^\circ\text{C}$
			60	μA	$V_{CC} < 5.5\text{ V}$, ADM8xxL/M/J, $T_A = 85^\circ\text{C}$ to 125°C
			60	μA	$V_{CC} < 3.6\text{ V}$, ADM8xxR/S/T/Z, $T_A = 85^\circ\text{C}$ to 125°C
RESET VOLTAGE THRESHOLD					
ADM8xxL	4.56	4.63	4.70	V	$T_A = 25^\circ\text{C}$
	4.50		4.75	V	$T_A = -40^\circ\text{C}$ to $+85^\circ\text{C}$
	4.44		4.82	V	$T_A = -40^\circ\text{C}$ to $+125^\circ\text{C}$
ADM8xxM	4.31	4.38	4.45	V	$T_A = 25^\circ\text{C}$
	4.25		4.50	V	$T_A = -40^\circ\text{C}$ to $+85^\circ\text{C}$
	4.20		4.56	V	$T_A = -40^\circ\text{C}$ to $+125^\circ\text{C}$
ADM8xxJ	3.93	4.00	4.06	V	$T_A = 25^\circ\text{C}$ (ADM809/ADM810 only)
	3.89		4.10	V	$T_A = -40^\circ\text{C}$ to $+85^\circ\text{C}$ (ADM809/ADM810 only)
	3.80		4.20	V	$T_A = -40^\circ\text{C}$ to $+125^\circ\text{C}$ (ADM809/ADM810 only)
ADM8xxT	3.04	3.08	3.11	V	$T_A = 25^\circ\text{C}$
	3.00		3.15	V	$T_A = -40^\circ\text{C}$ to $+85^\circ\text{C}$
	2.95		3.21	V	$T_A = -40^\circ\text{C}$ to $+125^\circ\text{C}$
ADM8xxS	2.89	2.93	2.96	V	$T_A = 25^\circ\text{C}$
	2.85		3.00	V	$T_A = -40^\circ\text{C}$ to $+85^\circ\text{C}$
	2.81		3.05	V	$T_A = -40^\circ\text{C}$ to $+125^\circ\text{C}$
ADM8xxR	2.59	2.63	2.66	V	$T_A = 25^\circ\text{C}$
	2.55		2.70	V	$T_A = -40^\circ\text{C}$ to $+85^\circ\text{C}$
	2.52		2.74	V	$T_A = -40^\circ\text{C}$ to $+125^\circ\text{C}$
ADM8xxZ	2.28	2.32	2.35	V	$T_A = 25^\circ\text{C}$
	2.25		2.38	V	$T_A = -40^\circ\text{C}$ to $+85^\circ\text{C}$
	2.22		2.42	V	$T_A = -40^\circ\text{C}$ to $+125^\circ\text{C}$
RESET THRESHOLD TEMPERATURE COEFFICIENT		30		ppm/ $^\circ\text{C}$	
V_{CC} to Reset Delay		20		μs	$V_{CC} = V_{TH}$ to $(V_{TH} - 100\text{ mV})$
RESET ACTIVE TIMEOUT PERIOD	140	240	460	ms	$T_A = -40^\circ\text{C}$ to $+85^\circ\text{C}$
	100		840	ms	$T_A = 85^\circ\text{C}$ to 125°C
RESET OUTPUT VOLTAGE LOW (ADM803/ADM809)			0.3	V	$V_{CC} = V_{TH}\text{ min}$, $I_{SINK} = 1.2\text{ mA}$, ADM803R/S/T/Z, ADM809R/S/T/Z
			0.4	V	$V_{CC} = V_{TH}\text{ min}$, $I_{SINK} = 3.2\text{ mA}$, ADM803L/M/J, ADM809L/M/J
			0.3	V	$V_{CC} > 1.0\text{ V}$, $I_{SINK} = 50\text{ }\mu\text{A}$
RESET OUTPUT VOLTAGE HIGH (ADM809)					
	$0.8 V_{CC}$			V	$V_{CC} > V_{TH}\text{ max}$, $I_{SOURCE} = 500\text{ }\mu\text{A}$, ADM809R/S/T/Z
	$V_{CC} - 1.5$			V	$V_{CC} > V_{TH}\text{ max}$, $I_{SOURCE} = 800\text{ }\mu\text{A}$, ADM809L/M/J
RESET OUTPUT VOLTAGE LOW (ADM810)			0.3	V	$V_{CC} = V_{TH}\text{ min}$, $I_{SINK} = 1.2\text{ mA}$, ADM810R/S/T/Z
			0.4	V	$V_{CC} = V_{TH}\text{ min}$, $I_{SINK} = 3.2\text{ mA}$, ADM810L/M/J
RESET OUTPUT VOLTAGE HIGH (ADM810)					
	$0.8 V_{CC}$			V	$1.8\text{ V} < V_{CC} < V_{TH}\text{ min}$, $I_{SOURCE} = 150\text{ }\mu\text{A}$
RESET OPEN-DRAIN OUTPUT					
Leakage Current (ADM803)			1	μA	$V_{CC} > V_{TH}$, $\overline{\text{RESET}}$ deasserted

ABSOLUTE MAXIMUM RATINGS

T_A = 25°C, unless otherwise noted.

Table 2.

Parameter	Ratings
V _{CC}	-0.3 V to +6 V
RESET, $\overline{\text{RESET}}$ (Push-Pull)	-0.3 V to V _{CC} + 0.5 V
RESET (Open-Drain)	-0.3 V to +6.0 V
Input Current	
V _{CC}	20 mA
Output Current	
RESET, $\overline{\text{RESET}}$	20 mA
Rate of Rise, V _{CC}	100 V/μs
θ _{JA} Thermal Impedance	
SC70	146°C/W
SOT-23	270°C/W
Lead Temperature (Soldering, 10 sec)	300°C
Vapor Phase (60 sec)	215°C
Infrared (15 sec)	220°C
Storage Temperature Range	-65°C to +150°C

Stresses at or above those listed under Absolute Maximum Ratings may cause permanent damage to the product. This is a stress rating only; functional operation of the product at these or any other conditions above those indicated in the operational section of this specification is not implied. Operation beyond the maximum operating conditions for extended periods may affect product reliability.

Table 3. Reset Threshold Options

RESET Model	Threshold (V)
ADM8xxL	4.63
ADM8xxM	4.38
ADM8xxJ (ADM809/ADM810 Only)	4.00
ADM8xxT	3.08
ADM8xxS	2.93
ADM8xxR	2.63
ADM8xxZ	2.32

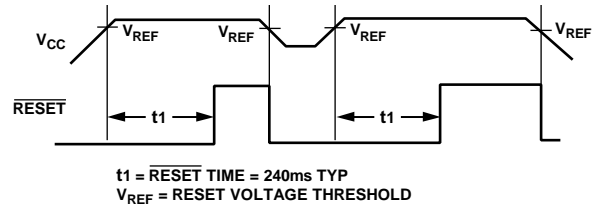

Figure 2. Power Fail Reset Timing

03796-003

ESD CAUTION



ESD (electrostatic discharge) sensitive device. Charged devices and circuit boards can discharge without detection. Although this product features patented or proprietary protection circuitry, damage may occur on devices subjected to high energy ESD. Therefore, proper ESD precautions should be taken to avoid performance degradation or loss of functionality.

PIN CONFIGURATIONS AND FUNCTION DESCRIPTIONS



Figure 3. ADM803/ADM809 Pin Configuration



Figure 4. ADM810 Pin Configuration

Table 4. Pin Function Descriptions

Pin No.		Mnemonic	Description
ADM803/ADM809	ADM810		
1	1	GND	Ground Reference for All Signals; 0 V.
N/A	2	RESET	Active High Logic Output. RESET remains high while V_{CC} is below the reset threshold and remains high for 240 ms (typical) after V_{CC} rises above the reset threshold.
2	N/A	$\overline{\text{RESET}}$	Active Low Logic Output. $\overline{\text{RESET}}$ remains low while V_{CC} is below the reset threshold and remains low for 240 ms (typical) after V_{CC} rises above the reset threshold.
3	3	V_{CC}	Supply Voltage Being Monitored.

TYPICAL PERFORMANCE CHARACTERISTICS



Figure 5. Supply Current vs. Temperature (No Load)

03736-004



Figure 8. Power-Up Reset Timeout vs. Temperature, ADM8xxR

03736-007

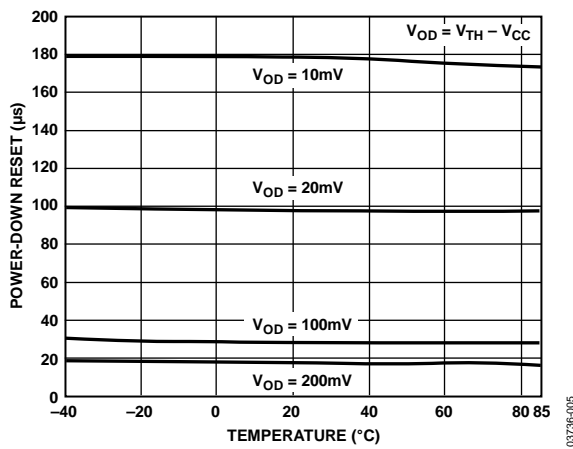

Figure 6. Power-Down Reset Delay vs. Temperature, ADM8xxL/M/J

03736-005

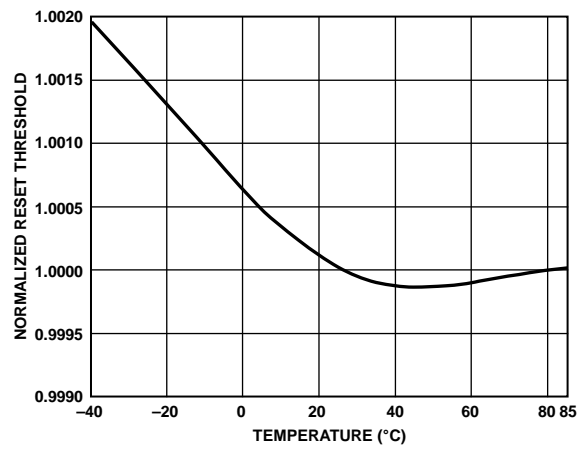

Figure 9. Normalized Reset Voltage Threshold vs. Temperature

03736-008



Figure 7. Power-Down Reset Delay vs. Temperature, ADM8xxT/S/R/Z

03736-006



Figure 10. Reset Output Voltage vs. Supply Voltage

03736-009



Figure 11. Maximum Transient Duration Without Causing a Reset Pulse vs. Reset Comparator Overdrive

INTERFACING TO OTHER DEVICES

The [ADM803/ADM809/ADM810](#) series is designed to integrate with as many devices as possible and, therefore, has a standard output dependent on V_{CC} . This enables the parts to be used in both 3 V and 5 V, or any nominal voltage within the minimum and maximum specifications for V_{CC} . This design simplifies interfacing the [ADM803/ADM809/ADM810](#) to other devices.

ENSURING A VALID RESET OUTPUT DOWN TO $V_{CC} = 0$ V

When V_{CC} falls below 0.8 V, the [ADM803/ADM809](#) $\overline{\text{RESET}}$ no longer sinks current. A high impedance CMOS logic input connected to $\overline{\text{RESET}}$ may, therefore, drift to undetermined logic levels. To eliminate this problem, a 100 k Ω resistor should be connected from $\overline{\text{RESET}}$ to ground.



Figure 12. Ensuring a Valid Reset Output Down to $V_{CC} = 0$ V

BENEFITS OF AN ACCURATE RESET THRESHOLD

In other microprocessors, tolerances in supply voltages lead to an overall increase in reset tolerance levels due to the deterioration of the reset circuit's power supply. In the

[ADM803/ADM809/ADM810](#), the possibility of a malfunction during a power failure is greatly reduced because the devices can operate effectively even when there are large degradations of the supply voltages. Another advantage is the very accurate internal voltage reference circuit of the [ADM803/ADM809/ADM810](#). These benefits combine to produce an exceptionally reliable voltage monitor circuit.

INTERFACING TO MICROPROCESSORS WITH MULTIPLE INTERRUPTS

In a number of cases, it is necessary to interface many interrupts from different devices (for example, thermal, altitude, and velocity sensors). The [ADM803/ADM809/ADM810](#) can easily be integrated into existing interrupt-handling circuits, as shown in Figure 13, or can be used as standalone devices.



Figure 13. Interfacing to Microprocessors with Multiple Interrupts

OUTLINE DIMENSIONS



COMPLIANT TO JEDEC STANDARDS TO-236-AB

Figure 14. 3-Lead Small Outline Transistor Package [SOT-23-3] (RT-3)

Dimensions shown in millimeters

011909-C

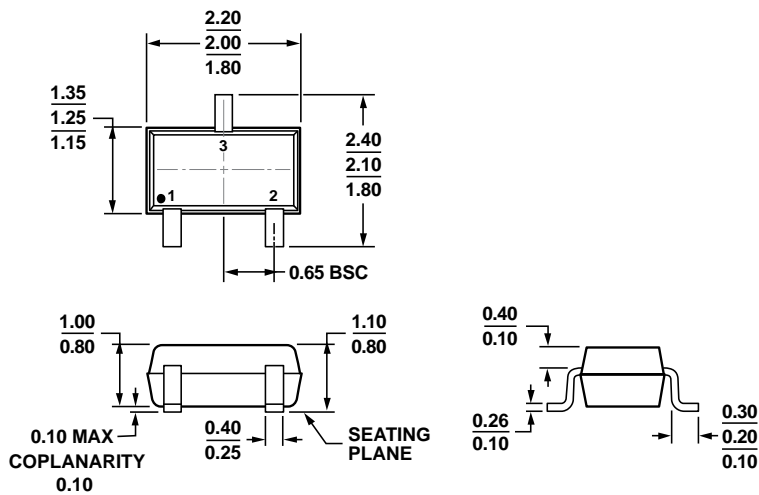

ALL DIMENSIONS COMPLIANT WITH EIAJ SC70

Figure 15. 3-Lead Thin Shrink Small Outline Transistor Package [SC70] (KS-3)

Dimensions shown in millimeters

072809-A

ORDERING GUIDE

Model ¹	Reset Threshold (V)	Temperature Range	Branding ^{2, 3}	Quantity	Package Description	Package Option
ADM803LAKSZ-REEL	4.63	-40°C to +125°C	M6L	10,000	3-Lead SC70	KS-3
ADM803LAKSZ-REEL7	4.63	-40°C to +125°C	M6L	3,000	3-Lead SC70	KS-3
ADM803MAKS-REEL7	4.38	-40°C to +125°C	M03	3,000	3-Lead SC70	KS-3
ADM803MAKSZ-REEL7	4.38	-40°C to +125°C	M6J	3,000	3-Lead SC70	KS-3
ADM803RAKSZ-REEL7	2.63	-40°C to +125°C	M6M	3,000	3-Lead SC70	KS-3
ADM803SAKS-REEL7	2.93	-40°C to +125°C	M06	3,000	3-Lead SC70	KS-3
ADM803SAKSZ-REEL	2.93	-40°C to +125°C	M50	10,000	3-Lead SC70	KS-3
ADM803SAKSZ-REEL7	2.93	-40°C to +125°C	M50	3,000	3-Lead SC70	KS-3
ADM803TAKS-REEL7	3.08	-40°C to +125°C	M05	3,000	3-Lead SC70	KS-3
ADM803TAKSZ-REEL7	3.08	-40°C to +125°C	M4M	3,000	3-Lead SC70	KS-3
ADM803ZAKSZ-REEL7	2.32	-40°C to +125°C	M6N	3,000	3-Lead SC70	KS-3
ADM809JAKS-REEL7	4.00	-40°C to +125°C	M9C or 9JXX	3,000	3-Lead SC70	KS-3
ADM809JAKSZ-REEL	4.00	-40°C to +125°C	M6P	10,000	3-Lead SC70	KS-3
ADM809JAKSZ-REEL7	4.00	-40°C to +125°C	M6P	3,000	3-Lead SC70	KS-3
ADM809JARTZ-REEL7	4.00	-40°C to +125°C	M6P	3,000	3-Lead SOT-23	RT-3
ADM809LAKS-REEL7	4.63	-40°C to +125°C	M9A	3,000	3-Lead SC70	KS-3
ADM809LAKSZ-REEL	4.63	-40°C to +125°C	M6R	10,000	3-Lead SC70	KS-3
ADM809LAKSZ-REEL7	4.63	-40°C to +125°C	M6R	3,000	3-Lead SC70	KS-3
ADM809LART-REEL7	4.63	-40°C to +125°C	9LXX	3,000	3-Lead SOT-23	RT-3
ADM809LARTZ-REEL	4.63	-40°C to +125°C	9LXX	10,000	3-Lead SOT-23	RT-3
ADM809LARTZ-REEL7	4.63	-40°C to +125°C	9LXX	3,000	3-Lead SOT-23	RT-3
ADM809MAKS-REEL7	4.38	-40°C to +125°C	M9B	3,000	3-Lead SC70	KS-3
ADM809MAKSZ-REEL	4.38	-40°C to +125°C	M51	10,000	3-Lead SC70	KS-3
ADM809MAKSZ-REEL7	4.38	-40°C to +125°C	M51	3,000	3-Lead SC70	KS-3
ADM809MART-REEL7	4.38	-40°C to +125°C	9MXX	3,000	3-Lead SOT-23	RT-3
ADM809MARTZ-REEL	4.38	-40°C to +125°C	M51	10,000	3-Lead SOT-23	RT-3
ADM809MARTZ-REEL7	4.38	-40°C to +125°C	M51	3,000	3-Lead SOT-23	RT-3
ADM809RAKS-REEL	2.63	-40°C to +125°C	M9F	10,000	3-Lead SC70	KS-3
ADM809RAKS-REEL7	2.63	-40°C to +125°C	M9F	3,000	3-Lead SC70	KS-3
ADM809RAKSZ-REEL	2.63	-40°C to +125°C	M4D	10,000	3-Lead SC70	KS-3
ADM809RAKSZ-REEL7	2.63	-40°C to +125°C	M4D	3,000	3-Lead SC70	KS-3
ADM809RART-REEL	2.63	-40°C to +125°C	9RXX	10,000	3-Lead SOT-23	RT-3
ADM809RART-REEL7	2.63	-40°C to +125°C	9RXX	3,000	3-Lead SOT-23	RT-3
ADM809RARTZ-REEL	2.63	-40°C to +125°C	M4D	10,000	3-Lead SOT-23	RT-3
ADM809RARTZ-REEL7	2.63	-40°C to +125°C	M4D	3,000	3-Lead SOT-23	RT-3
ADM809SAKS-REEL	2.93	-40°C to +125°C	M9E	10,000	3-Lead SC70	KS-3
ADM809SAKS-REEL7	2.93	-40°C to +125°C	M9E	3,000	3-Lead SC70	KS-3
ADM809SAKSZ-REEL	2.93	-40°C to +125°C	M53	10,000	3-Lead SC70	KS-3
ADM809SAKSZ-REEL7	2.93	-40°C to +125°C	M53	3,000	3-Lead SC70	KS-3
ADM809SART-REEL7	2.93	-40°C to +125°C	9SXX	3,000	3-Lead SOT-23	RT-3
ADM809SARTZ-REEL	2.93	-40°C to +125°C	M53	10,000	3-Lead SOT-23	RT-3
ADM809SARTZ-REEL7	2.93	-40°C to +125°C	M53	3,000	3-Lead SOT-23	RT-3
ADM809TAKS-REEL7	3.08	-40°C to +125°C	M9D	3,000	3-Lead SC70	KS-3
ADM809TAKSZ-REEL	3.08	-40°C to +125°C	M4K	10,000	3-Lead SC70	KS-3
ADM809TAKSZ-REEL7	3.08	-40°C to +125°C	M4K	3,000	3-Lead SC70	KS-3
ADM809TART-REEL7	3.08	-40°C to +125°C	9TXX	3,000	3-Lead SOT-23	RT-3
ADM809TARTZ-REEL	3.08	-40°C to +125°C	9TXX	10,000	3-Lead SOT-23	RT-3
ADM809TARTZ-REEL7	3.08	-40°C to +125°C	9TXX	3,000	3-Lead SOT-23	RT-3
ADM809ZAKS-REEL	2.32	-40°C to +125°C	M9G	10,000	3-Lead SC70	KS-3
ADM809ZAKS-REEL7	2.32	-40°C to +125°C	M9G	3,000	3-Lead SC70	KS-3
ADM809ZAKSZ-REEL	2.32	-40°C to +125°C	M4P	10,000	3-Lead SC70	KS-3

Model ¹	Reset Threshold (V)	Temperature Range	Branding ^{2, 3}	Quantity	Package Description	Package Option
ADM809ZAKSZ-REEL7	2.32	-40°C to +125°C	M4P	3,000	3-Lead SC70	KS-3
ADM809ZARTZ-REEL	2.32	-40°C to +125°C	9ZXX	10,000	3-Lead SOT-23	RT-3
ADM809ZARTZ-REEL	2.32	-40°C to +125°C	M4P	10,000	3-Lead SOT-23	RT-3
ADM809ZARTZ-REEL7	2.32	-40°C to +125°C	M4P	3,000	3-Lead SOT-23	RT-3
ADM810JAKSZ-REEL7	4.00	-40°C to +125°C	M6V	3,000	3-Lead SC70	KS-3
ADM810JARTZ-REEL7	4.00	-40°C to +125°C	M6V	3,000	3-Lead SOT-23	RT-3
ADM810LAKSZ-REEL7	4.63	-40°C to +125°C	M6W or ALXX	3,000	3-Lead SC70	KS-3
ADM810LARTZ-REEL	4.63	-40°C to +125°C	M6W or ALXX	10,000	3-Lead SOT-23	RT-3
ADM810LARTZ-REEL7	4.63	-40°C to +125°C	M6W or ALXX	3,000	3-Lead SOT-23	RT-3
ADM810MAKSZ-REEL7	4.38	-40°C to +125°C	M6S	3,000	3-Lead SC70	KS-3
ADM810MARTZ-REEL7	4.38	-40°C to +125°C	M6S	3,000	3-Lead SOT-23	RT-3
ADM810RAKSZ-REEL7	2.63	-40°C to +125°C	M52 or ARXX	3,000	3-Lead SC70	KS-3
ADM810RARTZ-REEL7	2.63	-40°C to +125°C	M52 or ARXX	3,000	3-Lead SOT-23	RT-3
ADM810SAKSZ-REEL7	2.93	-40°C to +125°C	M6T	3,000	3-Lead SC70	KS-3
ADM810SARTZ-REEL7	2.93	-40°C to +125°C	M6T	3,000	3-Lead SOT-23	RT-3
ADM810TAKSZ-REEL7	3.08	-40°C to +125°C	M4V	3,000	3-Lead SC70	KS-3
ADM810TARTZ-REEL7	3.08	-40°C to +125°C	M4V	3,000	3-Lead SOT-23	RT-3
ADM810ZAKSZ-REEL7	2.32	-40°C to +125°C	M6U	3,000	3-Lead SC70	KS-3
ADM810ZARTZ-REEL7	2.32	-40°C to +125°C	M6U	3,000	3-Lead SOT-23	RT-3

¹ Z = RoHS Compliant Part.

² XX = Date code, may be top or bottom marked.

³ RoHS compliant part has XX branded on the bottom of the device.

Looking for pricing, stock, or lifecycle information?

Click below to explore more details on WIN SOURCE:

 [View ADM809ZARTZ-REEL7 on WIN SOURCE](#)

 [Analog Devices Inc. Information](#)

Optimize Your Supply Chain with WIN SOURCE Solutions

-  Global Sourcing Solution
-  Obsolete Management
-  Cost Control Management
-  Shortage Management
-  Alternative Solution
-  Excess Inventory Management