



THE DATASHEET OF TLC374IDRG4



TLC374, TLC374Q, TLC374Y LinCMOS™ QUADRUPLE DIFFERENTIAL COMPARATORS

SLCS118C – NOVEMBER 1983 – REVISED MARCH 1999

AVAILABLE OPTIONS

T _A	V _{IO} max AT 25°C	PACKAGED DEVICES					CHIP FORM (Y)
		SMALL OUTLINE (D)	CHIP CARRIER (FK)	CERAMIC DIP (J)	PLASTIC DIP (N)	TSSOP (PW)	
0°C to 70°C	5 mV	TLC374CD	—	—	TLC374CN	TLC374CPW	TLC374Y
-40°C to 85°C	5 mV	TLC374ID	—	—	TLC374IN	—	—
-55°C to 125°C	5 mV	TLC374MD	TLC374MFK	TLC374MJ	TLC374MN	—	—
-40°C to 125°C	5 mV	TLC374QD	—	—	TLC374QN	—	—

The D packages are available taped and reeled. Add R suffix to device type (e.g., TLC374CDR).

equivalent schematic (each comparator)

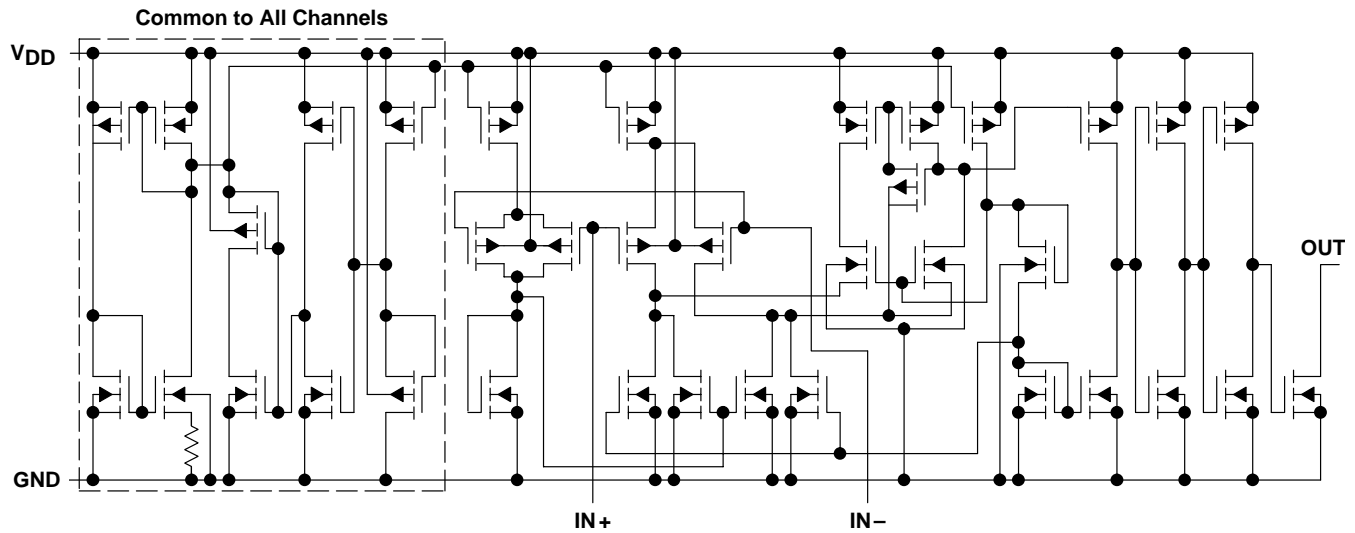

TLC374, TLC374Q, TLC374Y LinCMOS™ QUADRUPLE DIFFERENTIAL COMPARATORS

SLCS118C – NOVEMBER 1983 – REVISED MARCH 1999

TLC374Y chip information

This chip, when properly assembled, displays characteristics similar to the TLC374C. Thermal compression or ultrasonic bonding may be used on the doped-aluminum bonding pads. Chips may be mounted with conductive epoxy or a gold-silicon preform.

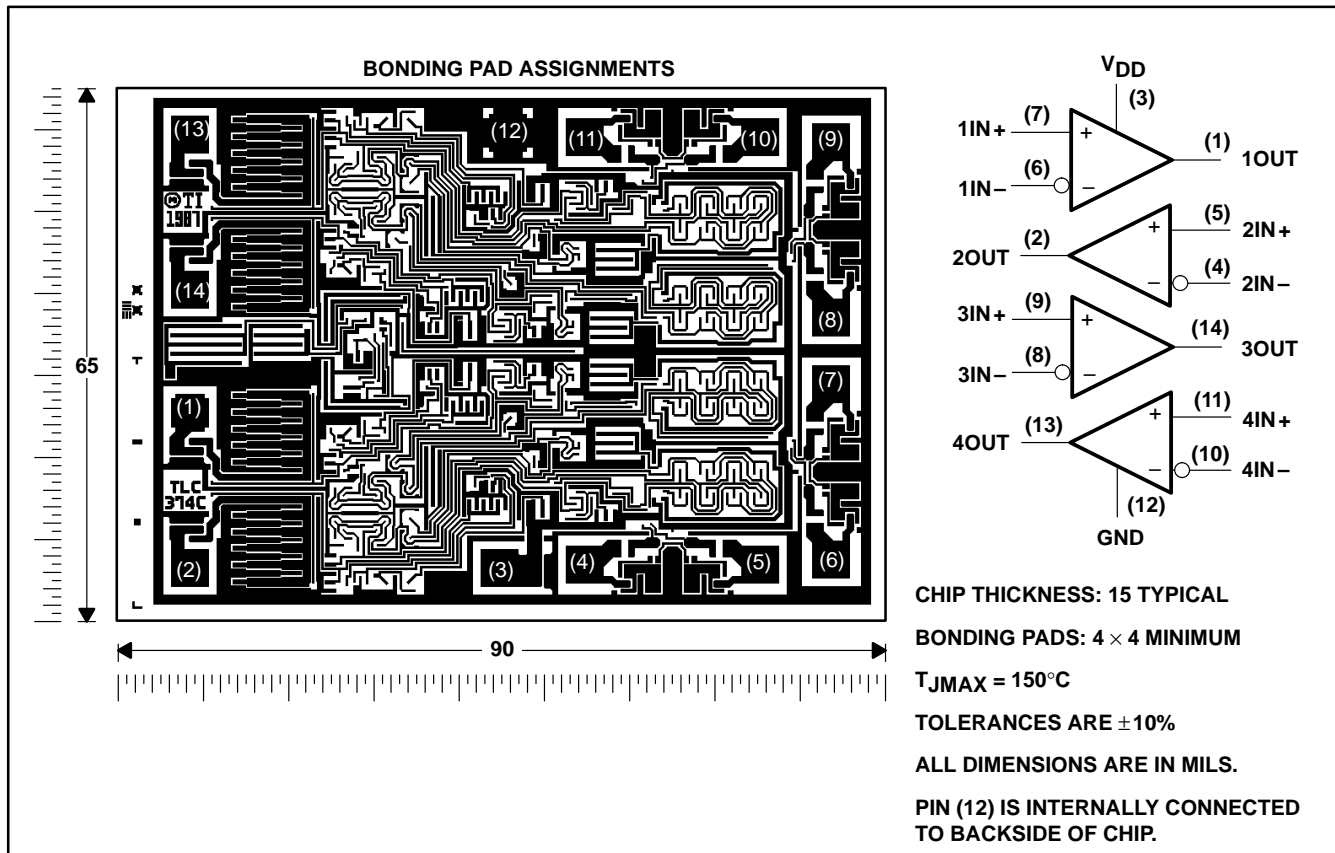

TLC374, TLC374Q, TLC374Y LinCMOS™ QUADRUPLE DIFFERENTIAL COMPARATORS

SLCS118C – NOVEMBER 1983 – REVISED MARCH 1999

absolute maximum ratings over operating free-air temperature range (unless otherwise noted)†

Supply voltage, V_{DD} (see Note 1)	18 V
Differential input voltage, V_{ID} (see Note 2)	± 18 V
Input voltage, V_I	V_{DD}
Input voltage range, V_I	-0.3 V to 18 V
Output voltage, V_O	18 V
Input current, I_I	± 5 mA
Output current, I_O	20 mA
Duration of output short circuit to ground (see Note 3)	unlimited
Continuous total power dissipation	See Dissipation Rating Table
Operating free-air temperature range, T_A : TLC374C	0°C to 70°C
TLC374I	-40°C to 85°C
TLC374M	-55°C to 125°C
TLC374Q	-40°C to 125°C
Storage temperature range, T_{stg}	-65°C to 150°C
Case temperature range for 60 seconds: FK package	260°C
Lead temperature 1,6 mm (1/16 inch) from case for 60 seconds: D, N, or PW package	260°C
Lead temperature 1,6 mm (1/16 inch) from case for 10 seconds: J package	300°C

† Stresses beyond those listed under “absolute maximum ratings” may cause permanent damage to the device. These are stress ratings only, and functional operation of the device at these or any other conditions beyond those indicated under “recommended operating conditions” is not implied. Exposure to absolute-maximum-rated conditions for extended periods may affect device reliability.

- NOTES: 1. All voltage values except differential voltages are with respect to network ground.
 2. Differential voltages are at $IN+$ with respect to $IN-$.
 3. Short circuits from outputs to V_{DD} can cause excessive heating and eventual device destruction.

DISSIPATION RATING TABLE

PACKAGE	$T_A \leq 25^\circ\text{C}$ POWER RATING	DERATING FACTOR	DERATE ABOVE T_A	$T_A = 70^\circ\text{C}$ POWER RATING	$T_A = 85^\circ\text{C}$ POWER RATING	$T_A = 125^\circ\text{C}$ POWER RATING
D	500 mW	7.6 mW/°C	84°C	500 mW	494 mW	190 mW
FK	500 mW	11.0 mW/°C	104°C	500 mW	500 mW	269 mW
J	500 mW	11.0 mW/°C	104°C	500 mW	500 mW	269 mW
N	500 mW	9.2 mW/°C	95°C	500 mW	500 mW	224 mW
PW	700 mW	5.6 mW/°C	—	448 mW	—	—

recommended operating conditions

	TLC374C		TLC374I		TLC374M		TLC374Q		UNIT
	MIN	MAX	MIN	MAX	MIN	MAX	MIN	MAX	
Supply voltage, V_{DD}	3	16	3	16	4	16	3	16	V
Common-mode input voltage, V_{IC}	$V_{DD} = 5$ V		0	3.5	0	3.5	0	3.5	V
	$V_{DD} = 10$ V		0	8.5	0	8.5	0	8.5	
Operating free-air temperature, T_A	0	70	-40	85	-55	125	-40	125	°C



electrical characteristics at specified free-air temperature, $V_{DD} = 5\text{ V}$

PARAMETER	TEST CONDITIONS	TA †	TLC374C			TLC374I		
			MIN	TYP	MAX	MIN	TYP	MAX
V_{IO} Input offset voltage	$V_{IC} = V_{ICRmin}$, See Note 4	25°C Full range	1	5	5	1	5	5
I_{IO} Input offset current		25°C MAX	1			1		
I_{IB} Input bias current		25°C MAX	5	0.3		5	1	
V_{ICR} Common-mode input voltage range		25°C Full range	0 to $V_{DD}-1$ $V_{DD}-1.5$			0 to $V_{DD}-1$ $V_{DD}-1.5$		0 to $V_{DD}-1$ $V_{DD}-1$
I_{OH} High-level output current	$V_{ID} = 1\text{ V}$ $V_{OH} = 5\text{ V}$ $V_{OH} = 15\text{ V}$	25°C Full range	0.1	1	1	0.1	1	
V_{OL} Low-level output voltage	$V_{ID} = -1\text{ V}$, $I_{OL} = 4\text{ mA}$	25°C Full range	150	400	400	150	400	
I_{OL} Low-level output current	$V_{ID} = -1\text{ V}$, $V_{OL} = 1.5\text{ V}$	25°C	6	16	16	6	16	6
I_{DD} Supply current (four comparators)	$V_{ID} = 1\text{ V}$, No load	25°C Full range	300	600	600	300	600	600
				800	800		800	800

† All characteristics are measured with zero common-mode input voltage unless otherwise noted. Full range is 0°C to 70°C for TLC374C, -40°C to 85°C for the TLC374M, and -40°C to 125°C for TLC374Q. MAX is 70°C for TLC374C, 85°C for TLC374I, and 125°C for the TLC374M, and 125°C for Parameter Measurement Information.

NOTE 4: The offset voltage limits given are the maximum values required to drive the output above 4 V or below 400 mV with a 10-k Ω resistor between the input and checking for the appropriate output state.

switching characteristics, $V_{DD} = 5\text{ V}$, $T_A = 25^\circ\text{C}$

PARAMETER	TEST CONDITIONS	TLC
		TLC MIN
Response time	R_L connected to 5 V through 5.1 k Ω , $C_L = 15\text{ pF}$ †, See Note 5	100-mV input step with 5-mV overdrive TTL-level input step

† C_L includes probe and jig capacitance.

NOTE 5: The response time specified is the interval between the input step function and the instant when the output crosses 1.4 V.

TLC374, TLC374Q, TLC374Y

LinCMOS™ QUADRUPLE DIFFERENTIAL COMPARATORS

SLCS118C – NOVEMBER 1983 – REVISED MARCH 1999

electrical characteristics at specified free-air temperature, $V_{DD} = 5\text{ V}$, $T_A = 25^\circ\text{C}$ (unless otherwise noted)

PARAMETER	TEST CONDITIONS	TLC374Y			UNIT
		MIN	TYP	MAX	
V_{IO} Input offset voltage	$V_{IC} = V_{ICRmin}$, See Note 4		1	5	mV
I_{IO} Input offset current			1		pA
I_{IB} Input bias current			5		pA
V_{ICR} Common-mode input voltage range		0 to $V_{DD}-1$			V
I_{OH} High-level output current	$V_{ID} = 1\text{ V}$, $V_{OH} = 5\text{ V}$		0.1		nA
V_{OL} Low-level output voltage	$V_{ID} = -1\text{ V}$, $I_{OL} = 4\text{ mA}$		150	400	mV
I_{OL} Low-level output current	$V_{ID} = -1\text{ V}$, $V_{OL} = 1.5\text{ mV}$	6	16		mA
I_{DD} Supply current (four comparators)	$V_{ID} = 1\text{ V}$, No load		300	600	μA

NOTE 4: The offset voltage limits given are the maximum values required to drive the output above 4 V or below 400 mV with a 10-k Ω resistor between the output and V_{DD} . They can be verified by applying the limit value to the input and checking for the appropriate output state.

switching characteristics, $V_{DD} = 5\text{ V}$, $T_A = 25^\circ\text{C}$

PARAMETER	TEST CONDITIONS		TLC374Y			UNIT
			MIN	TYP	MAX	
Response time	R_L connected to 5 V through 5.1 k Ω , $C_L = 15\text{ pF}$ †, See Note 5	100-mV input step with 5-mV overdrive		650		ns
		TTL-level input step		200		

† C_L includes probe and jig capacitance.

NOTE 4: The response time specified is the interval between the input step function and the instant when the output crosses 1.4 V.



PARAMETER MEASUREMENT INFORMATION

The digital output stage of the TLC374 can be damaged if it is held in the linear region of the transfer curve. Conventional operational amplifier/comparator testing incorporates the use of a servo loop that is designed to force the device output to a level within this linear region. Since the servo-loop method of testing cannot be used, the following alternative for measuring parameters such as input offset voltage, common-mode rejection, etc., are offered.

To verify that the input offset voltage falls within the limits specified, the limit value is applied to the input as shown in Figure 1(a). With the noninverting input positive with respect to the inverting input, the output should be high. With the input polarity reversed, the output should be low.

A similar test can be made to verify the input offset voltage at the common-mode extremes. The supply voltages can be slewed as shown in Figure 1(b) for the V_{ICR} test, rather than changing the input voltages, to provide greater accuracy.

A close approximation of the input offset voltage can be obtained by using a binary search method to vary the differential input voltage while monitoring the output state. When the applied input voltage differential is equal, but opposite in polarity to the input offset voltage, the output changes state.

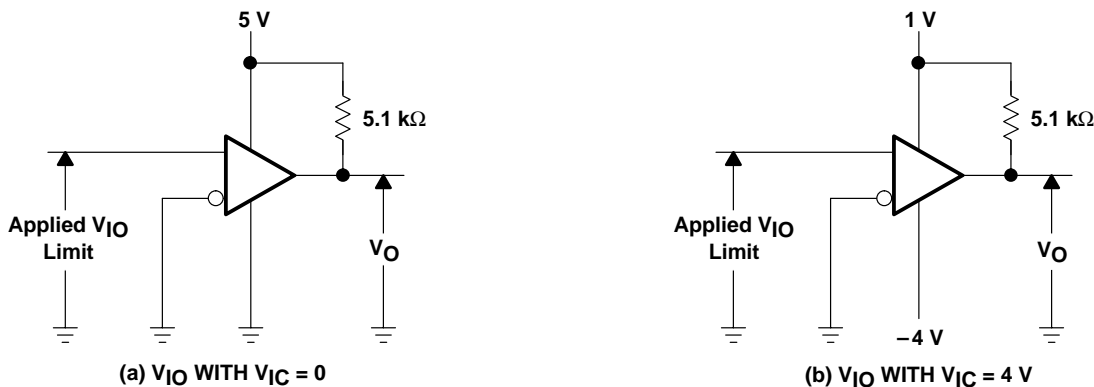

Figure 1. Method for Verifying That Input Offset Voltage is Within Specified Limits

TLC374, TLC374Q, TLC374Y LinCMOS™ QUADRUPLE DIFFERENTIAL COMPARATORS

SLCS118C – NOVEMBER 1983 – REVISED MARCH 1999

PARAMETER MEASUREMENT INFORMATION

Figure 2 illustrates a practical circuit for direct dc measurement of input offset voltage that does not bias the comparator into the linear region. The circuit consists of a switching-mode servo loop in which U1a generates a triangular waveform of approximately 20-mV amplitude. U1b acts as a buffer with C2 and R4 removing any residual dc offset. The signal is then applied to the inverting input of the comparator under test, while the noninverting input is driven by the output of the integrator formed by U1c through the voltage divider formed by R9 and R10. The loop reaches a stable operating point when the output of the comparator under test has a duty cycle of exactly 50%, which can only occur when the incoming triangle wave is sliced symmetrically or when the voltage at the noninverting input exactly equals the input offset voltage.

Voltage divider R9 and R10 provide a step up of the input offset voltage by a factor of 100 to make measurement easier. The values of R5, R8, R9, and R10 can significantly influence the accuracy of the reading; therefore, it is suggested that their tolerance level be 1% or lower.

Measuring the extremely low values of input current requires isolation from all other sources of leakage current and compensation for the leakage of the test socket and board. With a good picoammeter, the socket and board leakage can be measured with no device in the socket. Subsequently, this open-socket leakage value can be subtracted from the measurement obtained with a device in the socket to obtain the actual input current of the device.

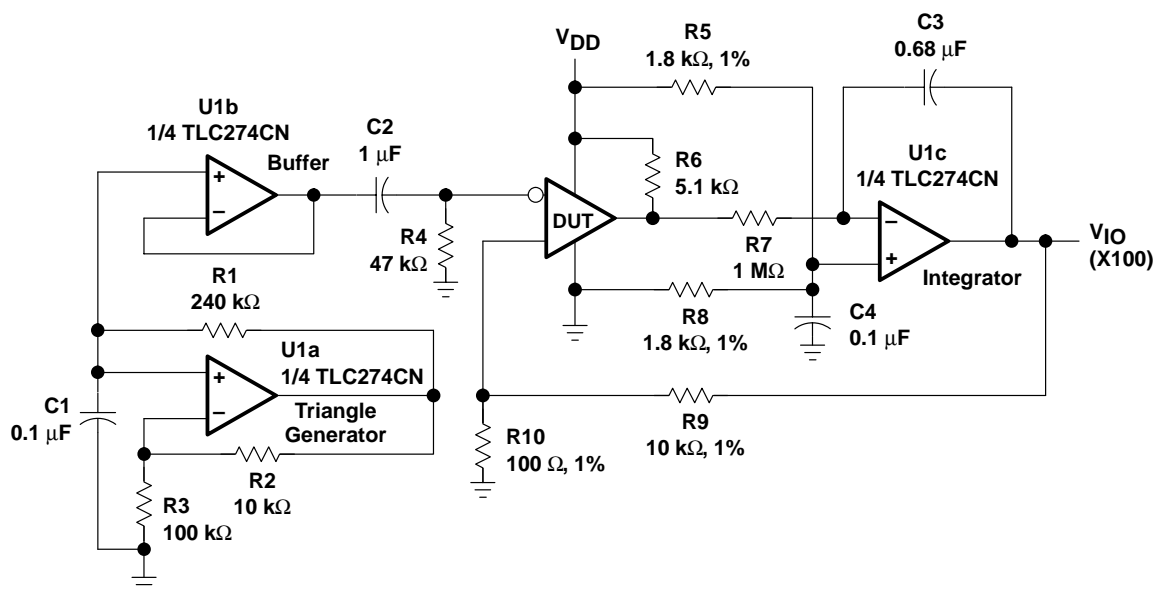
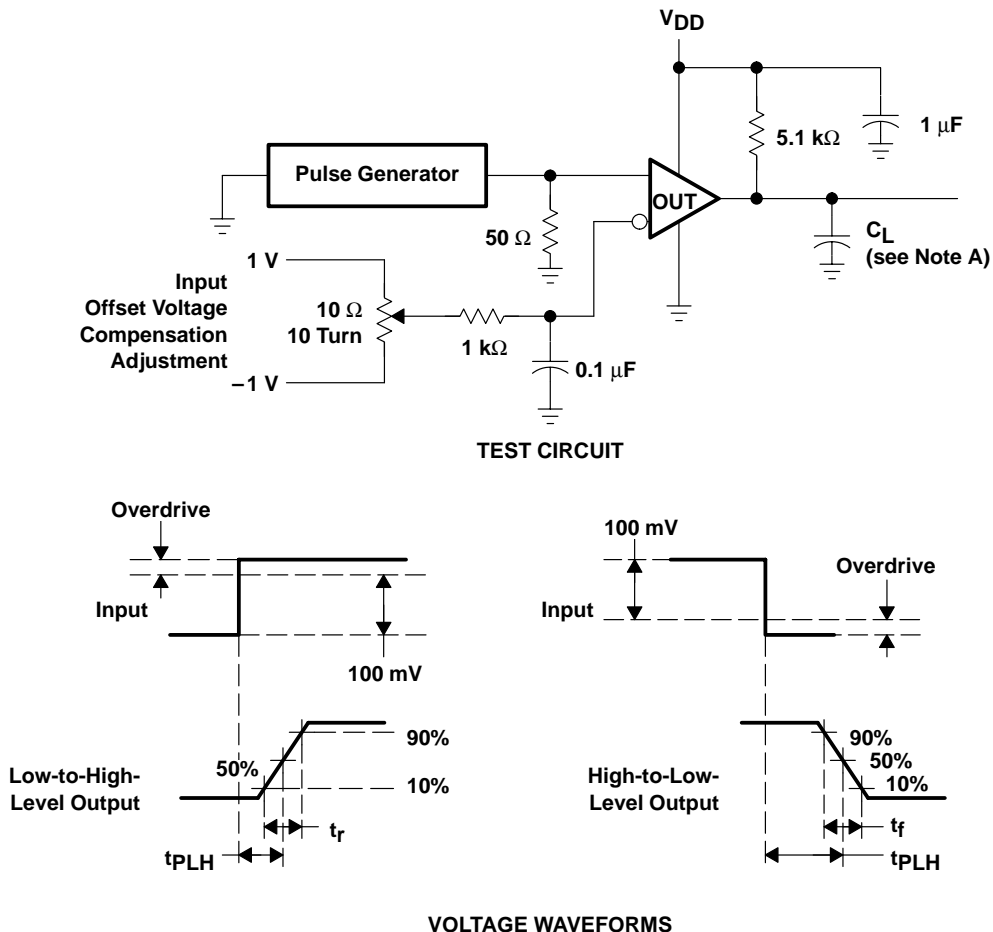

Figure 2. Test Circuit for Input Offset Voltage Measurement

PARAMETER MEASUREMENT INFORMATION

Response time is defined as the interval between the application of an input step function and the instant when the output reaches 50% of its maximum value. Response time, low-to-high-level output, is measured from the trailing edge of the input pulse. Response-time measurement at low input signal levels can be greatly affected by the input offset voltage. The offset voltage should be balanced by the adjustment at the inverting input (as shown in Figure 3) so that the circuit is just at the transition point. Then a low signal, for example, 105-mV or 5-mV overdrive, causes the output to change state.



NOTE A: C_L includes probe and jig capacitance.

Figure 3. Response, Rise, and Fall Times Test Circuit and Voltage Waveforms

PRINCIPLES OF OPERATION

LinCMOS process

LinCMOS process is a linear polysilicon-gate complimentary-MOS process. Primarily designed for single-supply applications, LinCMOS products facilitate the design of a wide range of high-performance analog functions from operational amplifiers to complex mixed-mode converters.

While digital designers are experienced with CMOS, MOS technologies are relatively new for analog designers. This short guide is intended to answer the most frequently asked questions related to the quality and reliability of LinCMOS products. Further questions should be directed to the nearest TI field sales office.

electrostatic discharge

CMOS circuits are prone to gate oxide breakdown when exposed to high voltages even if the exposure is only for very short periods of time. Electrostatic discharge (ESD) is one of the most common causes of damage to CMOS devices. It can occur when a device is handled without proper consideration for environmental electrostatic charges, e.g. during board assembly. If a circuit in which one amplifier from a dual operational amplifier is being used and the unused pins are left open, high voltages tends to develop. If there is no provision for ESD protection, these voltages may eventually punch through the gate oxide and cause the device to fail. To prevent voltage buildup, each pin is protected by internal circuitry.

Standard ESD-protection circuits safely shunt the ESD current by providing a mechanism whereby one or more transistors break down at voltages higher than normal operating voltages but lower than the breakdown voltage of the input gate. This type of protection scheme is limited by leakage currents which flow through the shunting transistors during normal operation after an ESD voltage has occurred. Although these currents are small, on the order of tens of nanoamps, CMOS amplifiers are often specified to draw input currents as low as tens of picoamps.

To overcome this limitation, TI design engineers developed the patented ESD-protection circuit shown in Figure 4. This circuit can withstand several successive 1-kV ESD pulses, while reducing or eliminating leakage currents that may be drawn through the input pins. A more detailed discussion of the operation of TI's ESD-protection circuit is presented on the next page.

All input an output pins of LinCMOS and Advanced LinCMOS products have associated ESD-protection circuitry that undergoes qualification testing to withstand 1000 V discharged from a 100-pF capacitor through a 1500-Ω resistor (human body model) and 200 V from a 100-pF capacitor with no current-limiting resistor (charged device model). These tests simulate both operator and machine handling of devices during normal test and assembly operations.

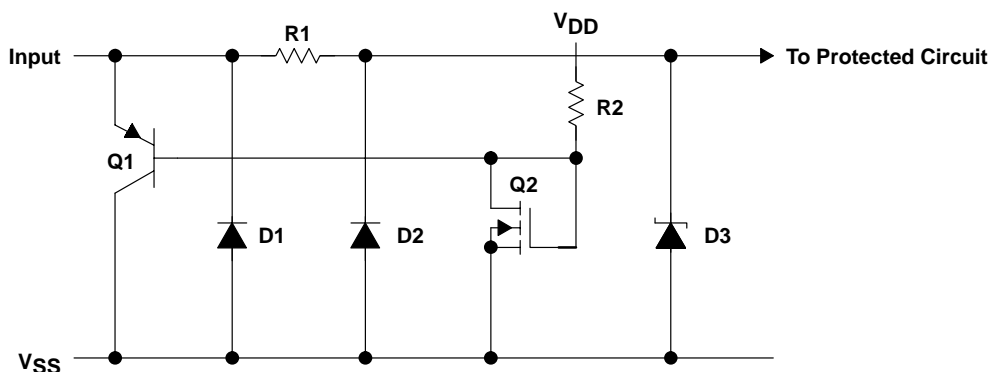

Figure 4. LinCMOS ESD-Protection Schematic

PRINCIPLES OF OPERATION

Input protection circuit operation

Texas Instruments patented protection circuitry allows for both positive- and negative-going ESD transients. These transients are characterized by extremely fast rise times and usually low energies, and can occur both when the device has all pins open and when it is installed in a circuit.

positive ESD transients

Initial positive charged energy is shunted through Q1 to V_{SS} . Q1 turns on when the voltage at the input rises above the voltage on V_{DD} by a value equal to the V_{EB} of Q1. The base current increases through R2 with input current as Q1 saturates. The base current through R2 as Q1 saturates forces the voltage at the drain and gate of Q2 to exceed its threshold level ($V_T \sim 22$ to 26 V) and turn on Q2. The shunted input current through Q1 to V_{SS} is now shunted through the n-channel enhancement-type MOSFET Q2 to V_{SS} . If the voltage on the input pin continues to rise, the breakdown voltage of D3 is exceeded and all remaining energy is dissipated in R1 and D3. The breakdown voltage of D3 is designed to be 24 V to 27 V, which is well below the gate oxide voltage of the circuit to be protected.

negative ESD transients

The negative charged ESD transients are shunted directly through D1. Additional energy is dissipated in R1 and D2 as D2 becomes forward-biased. The voltage seen by the protected circuit is -0.3 V to -1 V (the forward voltage of D1 and D2).

circuit-design considerations

LinCMOS products are being used in actual circuits environments that have input voltages that exceed the recommended common-mode input voltage range and activate the input protection circuit. Even under normal operation, these conditions occur during circuit power up or power down, and in many cases, when the device is being used for a signal conditioning function. The input voltages can exceed V_{ICR} and not damage the device only if the inputs are current limited. The recommended current limit shown on most product data sheets is ± 5 mA. Figures 5 and 6 show typical characteristics for input voltage vs input current.

Normal operation and correct output state can be expected even when the input voltage exceeds the positive supply voltage. The input current should be externally limited even though internal positive current limiting is achieved in the input protection circuit by the action of Q1. When Q1 is on, it saturates and limits the current to approximately 5-mA collector current by design. When saturated, Q1 base current increases with input current. This current is forced into the V_{DD} pin and into the device I_{DD} or the V_{DD} supply through R2 producing the current limiting effects shown in Figure 5. This internal limiting lasts only as long as the input voltage is below the V_T of Q2.

When the input voltage exceeds the negative supply voltage, normal operation is affected and output voltage states may not be correct. Also, the isolation between channels of multiple devices (duals and quads) can be severely affected. External current limiting must be used since this current is directly shunted by D1 and D2, and no internal limiting is achieved. If normal output voltage states are required, an external input voltage clamp is required (see Figure 7).

TLC374, TLC374Q, TLC374Y LinCMOS™ QUADRUPLE DIFFERENTIAL COMPARATORS

SLCS118C – NOVEMBER 1983 – REVISED MARCH 1999

PRINCIPLES OF OPERATION

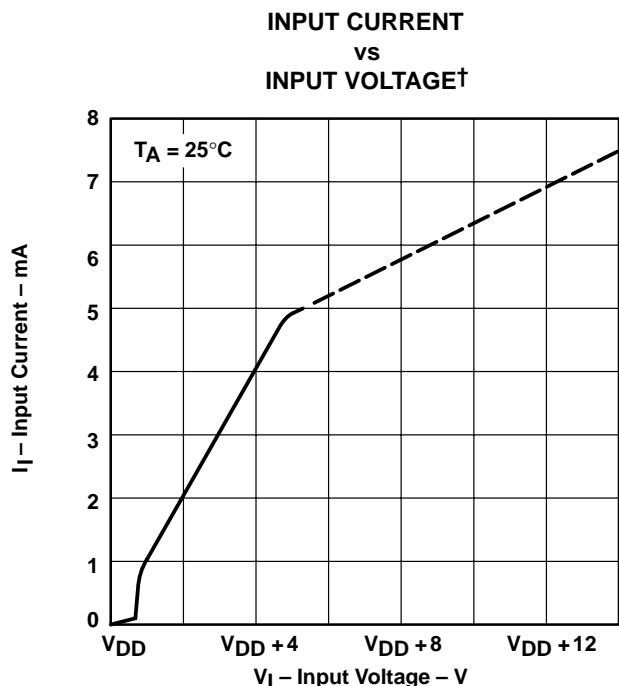

† The dashed line identifies an area of operation where some degradation of parametric performance may be experienced.

Figure 5

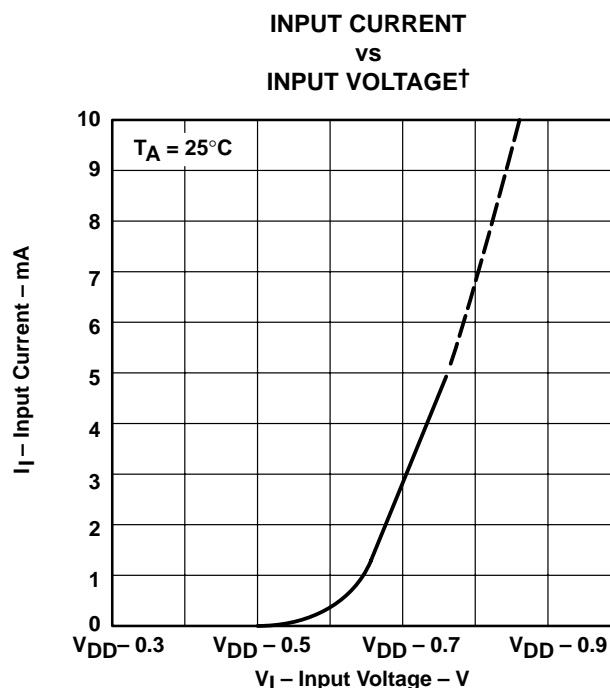

† The dashed line identifies an area of operation where some degradation of parametric performance may be experienced.

Figure 6

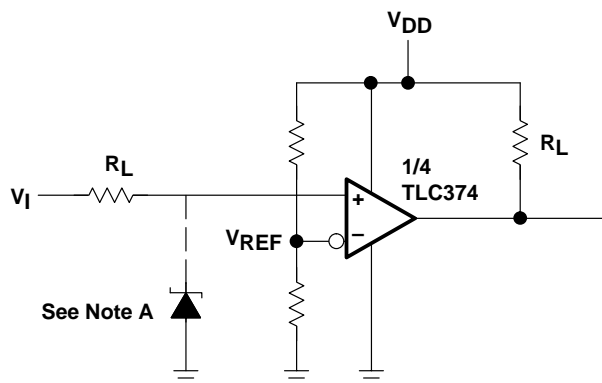

Positive Voltage Input Current Limit:

$$R_I = \frac{+V_I - V_{DD} - 0.3 \text{ V}}{5 \text{ mA}}$$

Negative Voltage Input Current Limit:

$$R_I = \frac{-V_I - V_{DD} - (0.3 \text{ V})}{5 \text{ mA}}$$

NOTE A: If the correct output state is required when the negative input exceeds V_{SS} , a Schottky clamp is required.

Figure 7. Typical Input Current-Limiting Configuration for a LinCMOS Comparator

PACKAGING INFORMATION

Orderable Device	Status (1)	Package Type	Package Drawing	Pins	Package Qty	Eco Plan (2)	Lead/Ball Finish (6)	MSL Peak Temp (3)	Op Temp (°C)	Device Marking (4/5)	Samples
5962-87659012A	ACTIVE	LCCC	FK	20	1	TBD	POST-PLATE	N / A for Pkg Type	-55 to 125	5962- 87659012A TLC374MFKB	Samples
5962-8765901CA	ACTIVE	CDIP	J	14	1	TBD	A42	N / A for Pkg Type	-55 to 125	5962-8765901CA TLC374MJB	Samples
TLC374CD	ACTIVE	SOIC	D	14	50	Green (RoHS & no Sb/Br)	CU NIPDAU	Level-1-260C-UNLIM	0 to 70	TLC374C	Samples
TLC374CDG4	ACTIVE	SOIC	D	14	50	Green (RoHS & no Sb/Br)	CU NIPDAU	Level-1-260C-UNLIM	0 to 70	TLC374C	Samples
TLC374CDR	ACTIVE	SOIC	D	14	2500	Green (RoHS & no Sb/Br)	CU NIPDAU	Level-1-260C-UNLIM	0 to 70	TLC374C	Samples
TLC374CDRG4	ACTIVE	SOIC	D	14	2500	Green (RoHS & no Sb/Br)	CU NIPDAU	Level-1-260C-UNLIM	0 to 70	TLC374C	Samples
TLC374CN	ACTIVE	PDIP	N	14	25	Green (RoHS & no Sb/Br)	CU NIPDAU	N / A for Pkg Type	0 to 70	TLC374CN	Samples
TLC374CN-A	ACTIVE	PDIP	N	14	25	Green (RoHS & no Sb/Br)	CU NIPDAU	N / A for Pkg Type	0 to 70	TLC374CN_A	Samples
TLC374CNE4	ACTIVE	PDIP	N	14	25	Green (RoHS & no Sb/Br)	CU NIPDAU	N / A for Pkg Type	0 to 70	TLC374CN	Samples
TLC374CPW	ACTIVE	TSSOP	PW	14	90	Green (RoHS & no Sb/Br)	CU NIPDAU	Level-1-260C-UNLIM	0 to 70	P374	Samples
TLC374CPWR	ACTIVE	TSSOP	PW	14	2000	Green (RoHS & no Sb/Br)	CU NIPDAU	Level-1-260C-UNLIM	0 to 70	P374	Samples
TLC374ID	ACTIVE	SOIC	D	14	50	Green (RoHS & no Sb/Br)	CU NIPDAU	Level-1-260C-UNLIM	-40 to 85	TLC374I	Samples
TLC374IDR	ACTIVE	SOIC	D	14	2500	Green (RoHS & no Sb/Br)	CU NIPDAU	Level-1-260C-UNLIM	-40 to 85	TLC374I	Samples
TLC374IDRG4	ACTIVE	SOIC	D	14	2500	Green (RoHS & no Sb/Br)	CU NIPDAU	Level-1-260C-UNLIM	-40 to 85	TLC374I	Samples
TLC374IN	ACTIVE	PDIP	N	14	25	Green (RoHS & no Sb/Br)	CU NIPDAU	N / A for Pkg Type	-40 to 85	TLC374IN	Samples
TLC374MD	ACTIVE	SOIC	D	14	50	Green (RoHS & no Sb/Br)	CU NIPDAU	Level-1-260C-UNLIM	-55 to 125	TLC374M	Samples

Orderable Device	Status (1)	Package Type	Package Drawing	Pins	Package Qty	Eco Plan (2)	Lead/Ball Finish (6)	MSL Peak Temp (3)	Op Temp (°C)	Device Marking (4/5)	Samples
TLC374MDG4	ACTIVE	SOIC	D	14	50	Green (RoHS & no Sb/Br)	CU NIPDAU	Level-1-260C-UNLIM		TLC374M	Samples
TLC374MFKB	ACTIVE	LCCC	FK	20	1	TBD	POST-PLATE	N / A for Pkg Type	-55 to 125	5962-87659012A TLC374MFKB	Samples
TLC374MJ	ACTIVE	CDIP	J	14	1	TBD	A42	N / A for Pkg Type	-55 to 125	TLC374MJ	Samples
TLC374MJB	ACTIVE	CDIP	J	14	1	TBD	A42	N / A for Pkg Type	-55 to 125	5962-8765901CA TLC374MJB	Samples

(1) The marketing status values are defined as follows:

ACTIVE: Product device recommended for new designs.

LIFEBUY: TI has announced that the device will be discontinued, and a lifetime-buy period is in effect.

NRND: Not recommended for new designs. Device is in production to support existing customers, but TI does not recommend using this part in a new design.

PREVIEW: Device has been announced but is not in production. Samples may or may not be available.

OBSELETE: TI has discontinued the production of the device.

(2) **RoHS:** TI defines "RoHS" to mean semiconductor products that are compliant with the current EU RoHS requirements for all 10 RoHS substances, including the requirement that RoHS substance do not exceed 0.1% by weight in homogeneous materials. Where designed to be soldered at high temperatures, "RoHS" products are suitable for use in specified lead-free processes. TI may reference these types of products as "Pb-Free".

RoHS Exempt: TI defines "RoHS Exempt" to mean products that contain lead but are compliant with EU RoHS pursuant to a specific EU RoHS exemption.

Green: TI defines "Green" to mean the content of Chlorine (Cl) and Bromine (Br) based flame retardants meet JS709B low halogen requirements of <=1000ppm threshold. Antimony trioxide based flame retardants must also meet the <=1000ppm threshold requirement.

(3) MSL, Peak Temp. - The Moisture Sensitivity Level rating according to the JEDEC industry standard classifications, and peak solder temperature.

(4) There may be additional marking, which relates to the logo, the lot trace code information, or the environmental category on the device.

(5) Multiple Device Markings will be inside parentheses. Only one Device Marking contained in parentheses and separated by a "~" will appear on a device. If a line is indented then it is a continuation of the previous line and the two combined represent the entire Device Marking for that device.

(6) Lead/Ball Finish - Orderable Devices may have multiple material finish options. Finish options are separated by a vertical ruled line. Lead/Ball Finish values may wrap to two lines if the finish value exceeds the maximum column width.

Important Information and Disclaimer: The information provided on this page represents TI's knowledge and belief as of the date that it is provided. TI bases its knowledge and belief on information provided by third parties, and makes no representation or warranty as to the accuracy of such information. Efforts are underway to better integrate information from third parties. TI has taken and continues to take reasonable steps to provide representative and accurate information but may not have conducted destructive testing or chemical analysis on incoming materials and chemicals. TI and TI suppliers consider certain information to be proprietary, and thus CAS numbers and other limited information may not be available for release.

In no event shall TI's liability arising out of such information exceed the total purchase price of the TI part(s) at issue in this document sold by TI to Customer on an annual basis.

OTHER QUALIFIED VERSIONS OF TLC374, TLC374M :

- Catalog: [TLC374](#)
- Military: [TLC374M](#)

NOTE: Qualified Version Definitions:

- Catalog - TI's standard catalog product
- Military - QML certified for Military and Defense Applications

TAPE AND REEL INFORMATION



QUADRANT ASSIGNMENTS FOR PIN 1 ORIENTATION IN TAPE



*All dimensions are nominal

Device	Package Type	Package Drawing	Pins	SPQ	Reel Diameter (mm)	Reel Width W1 (mm)	A0 (mm)	B0 (mm)	K0 (mm)	P1 (mm)	W (mm)	Pin1 Quadrant
TLC374CDR	SOIC	D	14	2500	330.0	16.4	6.5	9.0	2.1	8.0	16.0	Q1
TLC374CPWR	TSSOP	PW	14	2000	330.0	12.4	6.9	5.6	1.6	8.0	12.0	Q1
TLC374IDR	SOIC	D	14	2500	330.0	16.4	6.5	9.0	2.1	8.0	16.0	Q1

TAPE AND REEL BOX DIMENSIONS

*All dimensions are nominal

Device	Package Type	Package Drawing	Pins	SPQ	Length (mm)	Width (mm)	Height (mm)
TLC374CDR	SOIC	D	14	2500	333.2	345.9	28.6
TLC374CPWR	TSSOP	PW	14	2000	367.0	367.0	35.0
TLC374IDR	SOIC	D	14	2500	350.0	350.0	43.0

FK (S-CQCC-N**)

LEADLESS CERAMIC CHIP CARRIER

28 TERMINAL SHOWN



NO. OF TERMINALS **	A		B	
	MIN	MAX	MIN	MAX
20	0.342 (8,69)	0.358 (9,09)	0.307 (7,80)	0.358 (9,09)
28	0.442 (11,23)	0.458 (11,63)	0.406 (10,31)	0.458 (11,63)
44	0.640 (16,26)	0.660 (16,76)	0.495 (12,58)	0.560 (14,22)
52	0.740 (18,78)	0.761 (19,32)	0.495 (12,58)	0.560 (14,22)
68	0.938 (23,83)	0.962 (24,43)	0.850 (21,6)	0.858 (21,8)
84	1.141 (28,99)	1.165 (29,59)	1.047 (26,6)	1.063 (27,0)



4040140/D 01/11

- NOTES:
- All linear dimensions are in inches (millimeters).
 - This drawing is subject to change without notice.
 - This package can be hermetically sealed with a metal lid.
 - Falls within JEDEC MS-004

J 14

GENERIC PACKAGE VIEW
CDIP - 5.08 mm max height
CERAMIC DUAL IN LINE PACKAGE



Images above are just a representation of the package family, actual package may vary.
Refer to the product data sheet for package details.

4040083-5/G

J0014A



PACKAGE OUTLINE

CDIP - 5.08 mm max height

CERAMIC DUAL IN LINE PACKAGE



4214771/A 05/2017

NOTES:

1. All controlling linear dimensions are in inches. Dimensions in brackets are in millimeters. Any dimension in brackets or parenthesis are for reference only. Dimensioning and tolerancing per ASME Y14.5M.
2. This drawing is subject to change without notice.
3. This package is hermetically sealed with a ceramic lid using glass frit.
4. Index point is provided on cap for terminal identification only and on press ceramic glass frit seal only.
5. Falls within MIL-STD-1835 and GDIP1-T14.

EXAMPLE BOARD LAYOUT

J0014A

CDIP - 5.08 mm max height

CERAMIC DUAL IN LINE PACKAGE



LAND PATTERN EXAMPLE
NON-SOLDER MASK DEFINED
SCALE: 5X

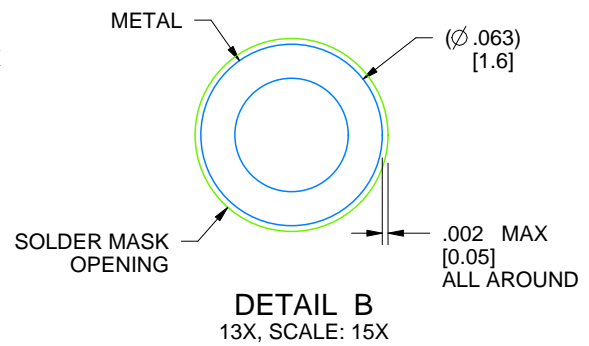

4214771/A 05/2017

D (R-PDSO-G14)

PLASTIC SMALL OUTLINE



4211283-3/E 08/12

- NOTES:
- A. All linear dimensions are in millimeters.
 - B. This drawing is subject to change without notice.
 - C. Publication IPC-7351 is recommended for alternate designs.
 - D. Laser cutting apertures with trapezoidal walls and also rounding corners will offer better paste release. Customers should contact their board assembly site for stencil design recommendations. Refer to IPC-7525 for other stencil recommendations.
 - E. Customers should contact their board fabrication site for solder mask tolerances between and around signal pads.

PW (R-PDSO-G14)

PLASTIC SMALL OUTLINE



4211284-2/G 08/15

- NOTES:
- All linear dimensions are in millimeters.
 - This drawing is subject to change without notice.
 - Publication IPC-7351 is recommended for alternate designs.
 - Laser cutting apertures with trapezoidal walls and also rounding corners will offer better paste release. Customers should contact their board assembly site for stencil design recommendations. Refer to IPC-7525 for other stencil recommendations.
 - Customers should contact their board fabrication site for solder mask tolerances between and around signal pads.

N (R-PDIP-T**)

PLASTIC DUAL-IN-LINE PACKAGE

16 PINS SHOWN



- NOTES:
- A. All linear dimensions are in inches (millimeters).
 - B. This drawing is subject to change without notice.
 - $\triangle C$ Falls within JEDEC MS-001, except 18 and 20 pin minimum body length (Dim A).
 - $\triangle D$ The 20 pin end lead shoulder width is a vendor option, either half or full width.

4040049/E 12/2002

IMPORTANT NOTICE AND DISCLAIMER

TI PROVIDES TECHNICAL AND RELIABILITY DATA (INCLUDING DATASHEETS), DESIGN RESOURCES (INCLUDING REFERENCE DESIGNS), APPLICATION OR OTHER DESIGN ADVICE, WEB TOOLS, SAFETY INFORMATION, AND OTHER RESOURCES "AS IS" AND WITH ALL FAULTS, AND DISCLAIMS ALL WARRANTIES, EXPRESS AND IMPLIED, INCLUDING WITHOUT LIMITATION ANY IMPLIED WARRANTIES OF MERCHANTABILITY, FITNESS FOR A PARTICULAR PURPOSE OR NON-INFRINGEMENT OF THIRD PARTY INTELLECTUAL PROPERTY RIGHTS.

These resources are intended for skilled developers designing with TI products. You are solely responsible for (1) selecting the appropriate TI products for your application, (2) designing, validating and testing your application, and (3) ensuring your application meets applicable standards, and any other safety, security, or other requirements. These resources are subject to change without notice. TI grants you permission to use these resources only for development of an application that uses the TI products described in the resource. Other reproduction and display of these resources is prohibited. No license is granted to any other TI intellectual property right or to any third party intellectual property right. TI disclaims responsibility for, and you will fully indemnify TI and its representatives against, any claims, damages, costs, losses, and liabilities arising out of your use of these resources.

TI's products are provided subject to TI's Terms of Sale (www.ti.com/legal/termsofsale.html) or other applicable terms available either on ti.com or provided in conjunction with such TI products. TI's provision of these resources does not expand or otherwise alter TI's applicable warranties or warranty disclaimers for TI products.

Mailing Address: Texas Instruments, Post Office Box 655303, Dallas, Texas 75265
Copyright © 2019, Texas Instruments Incorporated

Looking for pricing, stock, or lifecycle information?

Click below to explore more details on WIN SOURCE:

 [View TLC374IDRG4 on WIN SOURCE](#)

 [Texas Instruments](#) Information

Optimize Your Supply Chain with WIN SOURCE Solutions

-  Global Sourcing Solution
-  Obsolete Management
-  Cost Control Management
-  Shortage Management
-  Alternative Solution
-  Excess Inventory Management