



**THE DATASHEET OF  
ST485ERXDR**



**±15 kV ESD protected, low-power RS-485/RS-422 transceiver**

Datasheet - production data

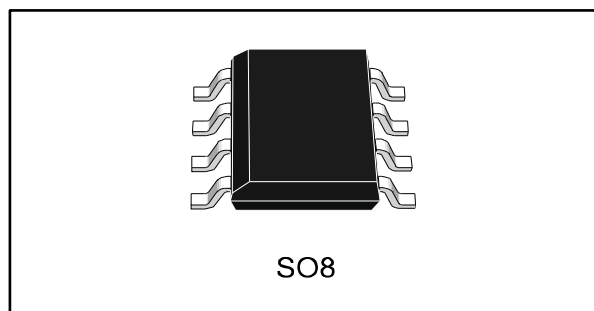
**Features**

- Low quiescent current: 300  $\mu$ A
- Designed for RS-485 interface applications
- - 7 V to 12 V common mode input voltage range
- Driver maintains high impedance in 3-state or with the power OFF
- 70 mV typical input hysteresis
- 30 ns propagation delay, 5 ns skew
- Operates from a single 5 V supply
- Current limiting and thermal shutdown for driver overload protection
- ESD protection:
  - $\pm 15$  kV (HBM)
  - $\pm 8$  kV (IEC-1000-4-2 contact discharge)
- Allows up to 64 transceivers on the bus

**Description**

The ST485ERB is a low-power transceiver for RS-485 and RS-422 communication. Each driver output and receiver input is protected against  $\pm 15$  kV electrostatic discharge (HBM)  $\pm 8$  kV (IEC-1000-4-2 contact discharge) shocks, without latch-up. These parts contain one driver and one receiver.

This transceiver draws 300  $\mu$ A (typ.) of supply current when unloaded or fully loaded with disabled drivers.

It operates from a single 5 V supply.

The driver is a short-circuit current which is limited and protected against excessive power dissipation by thermal shutdown circuitry that places the driver outputs into a high-impedance state.

The ST485ERB is designed for bi-directional data communication on multipoint bus transmission lines (half-duplex applications).

---

## Contents

<b>1</b>	<b>Pin settings</b> .....	<b>3</b>
<b>2</b>	<b>Truth tables</b> .....	<b>4</b>
<b>3</b>	<b>Maximum ratings</b> .....	<b>5</b>
<b>4</b>	<b>Electrical characteristics</b> .....	<b>6</b>
<b>5</b>	<b>Test circuit and typical characteristics</b> .....	<b>9</b>
<b>6</b>	<b>Package information</b> .....	<b>14</b>
	6.1    SO8 package information.....	15
	6.2    SO8 tape and reel information .....	16
<b>7</b>	<b>Ordering information</b> .....	<b>17</b>
<b>8</b>	<b>Revision history</b> .....	<b>18</b>

# 1 Pin settings

Figure 1: Pin configuration

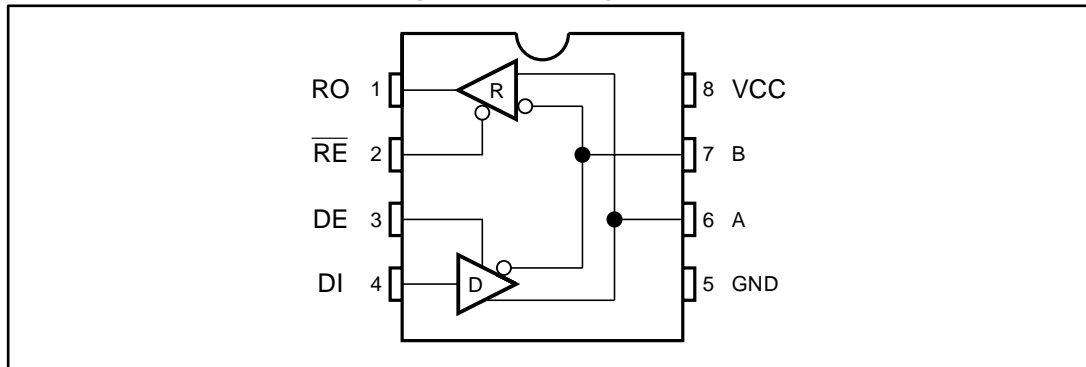

Table 1: Pin description

Pin number	Symbol	Name and function
1	RO	Receiver output
2	$\overline{\text{RE}}$	Receiver output enable
3	DE	Driver output enable
4	DI	Driver input
5	GND	Ground
6	A	Non-inverting receiver input and non-inverting driver output
7	B	Inverting receiver input and inverting driver output
8	V <sub>CC</sub>	Supply voltage

## 2 Truth tables

Table 2: Truth table (driver)

Inputs			Outputs	
$\overline{\text{RE}}$	DE	DI	B	A
X	H	H	L	H
		L	H	L
	L	X	Z	Z

**Note:** X = “don’t care”; Z = high impedance

Table 3: Truth table (receiver)

Inputs			Outputs
$\overline{\text{RE}}$	DE	A-B	RO
L	L	$\geq 0.2 \text{ V}$	H
		$\leq -0.2 \text{ V}$	L
		Inputs open	H
H		X	Z

**Note:** X = “don’t care”; Z = high impedance

### 3 Maximum ratings

Absolute maximum ratings are those values beyond which damage to the device may occur. Functional operation under these condition is not implied.

**Table 4: Absolute maximum ratings**

Symbol	Parameter	Value	Unit
$V_{CC}$	Supply voltage	7	V
$V_I$	Control input voltage ( $\overline{RE}$ , DE)	-0.5 to ( $V_{CC} + 0.5$ )	
$V_{DI}$	Driver input voltage (DI)	-0.5 to ( $V_{CC} + 0.5$ )	
$V_{DO}$	Driver output voltage (A, B)	$\pm 14$	
$V_{RI}$	Receiver input voltage (A, B)	$\pm 14$	
$V_{RO}$	Receiver output voltage (RO)	-0.5 to ( $V_{CC} + 0.5$ )	

## 4 Electrical characteristics

Table 5: ESD performance: transmitter outputs, receiver inputs

Symbol	Parameter	Test conditions	Min.	Typ.	Max.	Unit
ESD	ESD protection voltage	Human body model	±15	—	—	kV
		IEC-1000-4-2	±8			

In the EC tables below,  $V_{CC} = 5\text{ V} \pm 5\%$ ,  $T_A = T_{MIN}$  to  $T_{MAX}$ , unless otherwise specified. Typical values are referred to  $T_A = 25\text{ °C}$ .

Table 6: DC electrical characteristics

Symbol	Parameter	Test conditions <sup>(1)</sup>	Min.	Typ.	Max.	Unit	
$V_{OD1}$	Differential driver output (no load)				5	V	
$V_{OD2}$	Differential driver output (with load)	$R_L = 27\ \Omega$ (RS-485), see <a href="#">Figure 2</a>	1.5		5		
		$R_L = 50\ \Omega$ (RS-422), see <a href="#">Figure 2</a>	1.5		5		
$\Delta V_{OD}$	Change in magnitude of driver differential output voltage for complementary output states	$R_L = 27\ \Omega$ or $50\ \Omega$ , see <a href="#">Figure 2</a>			0.2		
$V_{OC}$	Driver common-mode output voltage	$R_L = 27\ \Omega$ or $50\ \Omega$ , see <a href="#">Figure 2</a>			3		
$\Delta V_{OC}$	Change in magnitude of driver common-mode output voltage for complementary output states	$R_L = 27\ \Omega$ or $50\ \Omega$ , see <a href="#">Figure 2</a>			0.2		
$V_{IH}$	Input high voltage	$\overline{RE}$ , DE, DI	2.0				
$V_{IL}$	Input low voltage	$\overline{RE}$ , DE, DI			0.8		
$I_{IN1}$	Input current	$\overline{RE}$ , DE, DI			± 2		µA
$I_{IN2}$	Input current (A, B), $V_{CM} = 0\text{ V}$ or $5.25\text{ V}$ , $V_{DE} = 0\text{ V}$	$V_{IN} = 12\text{ V}$			1		mA
		$V_{IN} = -7\text{ V}$			-0.8		
$V_{TH}$	Receiver differential threshold voltage	$V_{CM} = -7$ to $12\text{ V}$	-0.2		0.2	V	
$\Delta V_{TH}$	Receiver input hysteresis	$V_{CM} = 0\text{ V}$		70		mV	
$V_{OH}$	Receiver output high voltage	$I_O = -4\text{ mA}$ , $V_{ID} = 200\text{ mV}$	3.5			V	
$V_{OL}$	Receiver output low voltage	$I_O = 4\text{ mA}$ , $V_{ID} = -200\text{ mV}$			0.4		
$I_{OZR}$	3-state (high impedance) output current at receiver	$V_O = 0.4$ to $2.4\text{ V}$			± 1	µA	
$R_{IN}$	Receiver input resistance	$V_{CM} = -7$ to $12\text{ V}$	24			kΩ	
$I_{CC}$	No load supply current, $V_{RE} = 0\text{ V}$ or $V_{CC}$ <sup>(2)</sup>	$V_{DE} = V_{CC}$		400	900	µA	
		$V_{DE} = 0\text{ V}$		300	500		

Symbol	Parameter	Test conditions <sup>(1)</sup>	Min.	Typ.	Max.	Unit
I <sub>OSD1</sub>	Driver short-circuit current, V <sub>O</sub> = high	V <sub>O</sub> = -7 to 12 V <sup>(3)</sup>	35		250	mA
I <sub>OSD2</sub>	Driver short-circuit current, V <sub>O</sub> = low	V <sub>O</sub> = -7 to 12 V <sup>(3)</sup>	35		250	
I <sub>OSR</sub>	Receiver short-circuit current	V <sub>O</sub> = 0 V to V <sub>CC</sub>	7		95	

**Notes:**

<sup>(1)</sup>All currents into device pins are positive; all currents out of device pins are negative; all voltages are referenced to device ground unless specified.

<sup>(2)</sup>Supply current specification is valid for loaded transmitters when V<sub>DE</sub> = 0 V

<sup>(3)</sup>Applies to peak current

**Table 7: Driver switching characteristics**

Symbol	Parameter	Test conditions <sup>(1)</sup>	Min.	Typ.	Max.	Unit
t <sub>PLH</sub> , t <sub>PHL</sub>	Propagation delay input to output	R <sub>DIFF</sub> = 54 Ω, C <sub>L1</sub> = C <sub>L2</sub> = 100 pF, see <a href="#">Figure 4</a> and <a href="#">Figure 6</a>	10	30	60	ns
t <sub>SK</sub>	Output skew to output	R <sub>DIFF</sub> = 54 Ω, C <sub>L1</sub> = C <sub>L2</sub> = 100 pF, see <a href="#">Figure 4</a> and <a href="#">Figure 6</a>		5	10	
t <sub>TLH</sub> , t <sub>THL</sub>	Rise or fall time	R <sub>DIFF</sub> = 54 Ω, C <sub>L1</sub> = C <sub>L2</sub> = 100 pF, see <a href="#">Figure 4</a> and <a href="#">Figure 6</a>	3	15	40	
t <sub>PZH</sub>	Output enable time	C <sub>L</sub> = 100 pF, S2 = closed, see <a href="#">Figure 5</a> and <a href="#">Figure 7</a>		70	90	
t <sub>PZL</sub>	Output enable time	C <sub>L</sub> = 100 pF, S1 = closed, see <a href="#">Figure 5</a> and <a href="#">Figure 7</a>		70	90	
t <sub>PLZ</sub>	Output disable time	C <sub>L</sub> = 15 pF, S1 = closed, see <a href="#">Figure 5</a> and <a href="#">Figure 7</a>		70	90	
t <sub>PHZ</sub>	Output disable time	C <sub>L</sub> = 15 pF, S2 = closed, see <a href="#">Figure 5</a> and <a href="#">Figure 7</a>		70	90	
C <sub>AB</sub>	Output AB capacitance			43		pF

**Notes:**

<sup>(1)</sup>All currents into device pins are positive; all currents out of device pins are negative; all voltages are referenced to device ground unless specified.

Table 8: Receiver switching characteristics

Symbol	Parameter	Test conditions <sup>(1)</sup>	Min.	Typ.	Max.	Unit
t <sub>PLH</sub> , t <sub>PHL</sub>	Propagation delay input to output	R <sub>DIFF</sub> = 54 Ω, C <sub>L1</sub> = C <sub>L2</sub> = 100 pF, see <a href="#">Figure 4</a> and <a href="#">Figure 8</a>	20	130	210	ns
t <sub>SKD</sub>	Differential receiver skew	R <sub>DIFF</sub> = 54 Ω, C <sub>L1</sub> = C <sub>L2</sub> = 100 pF, see <a href="#">Figure 4</a> and <a href="#">Figure 8</a>		13		
t <sub>PZH</sub>	Output enable time	C <sub>RL</sub> = 15 pF, S1 = closed, see <a href="#">Figure 2</a> and <a href="#">Figure 9</a>		20	50	
t <sub>PZL</sub>	Output enable time	C <sub>RL</sub> = 15 pF, S2 = closed, see <a href="#">Figure 2</a> and <a href="#">Figure 9</a>		20	50	
t <sub>PLZ</sub>	Output disable time	C <sub>RL</sub> = 15 pF, S1 = closed, see <a href="#">Figure 2</a> and <a href="#">Figure 9</a>		20	50	
t <sub>PHZ</sub>	Output disable time	C <sub>RL</sub> = 15 pF, S2 = closed, see <a href="#">Figure 2</a> and <a href="#">Figure 9</a>		20	50	
f <sub>MAX</sub>	Maximum data rate		2.5			Mbps

**Notes:**

<sup>(1)</sup>All currents into device pins are positive; all currents out of device pins are negative; all voltages are referenced to device ground unless specified

## 5 Test circuit and typical characteristics

Figure 2: Driver DC test load

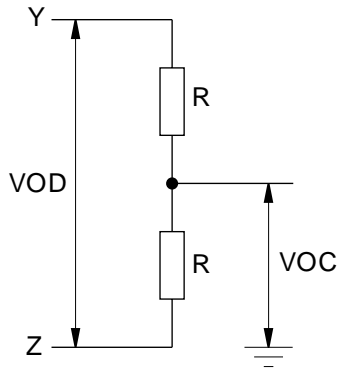

Figure 3: Receiver timing test load

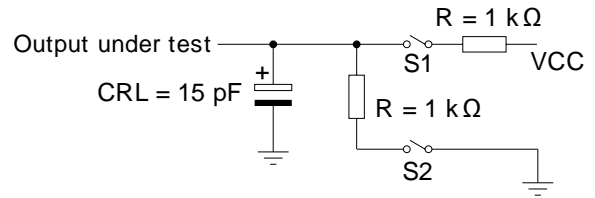

Figure 4: Drive/receiver timing test circuit

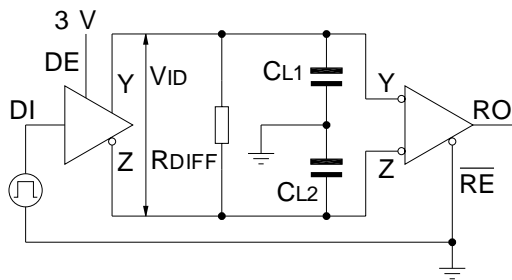
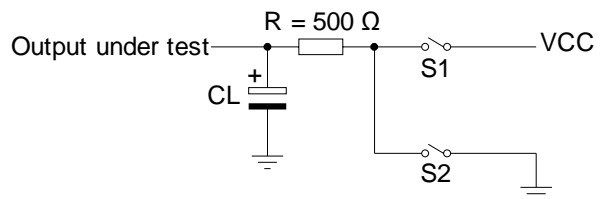

Figure 5: Driver timing test load



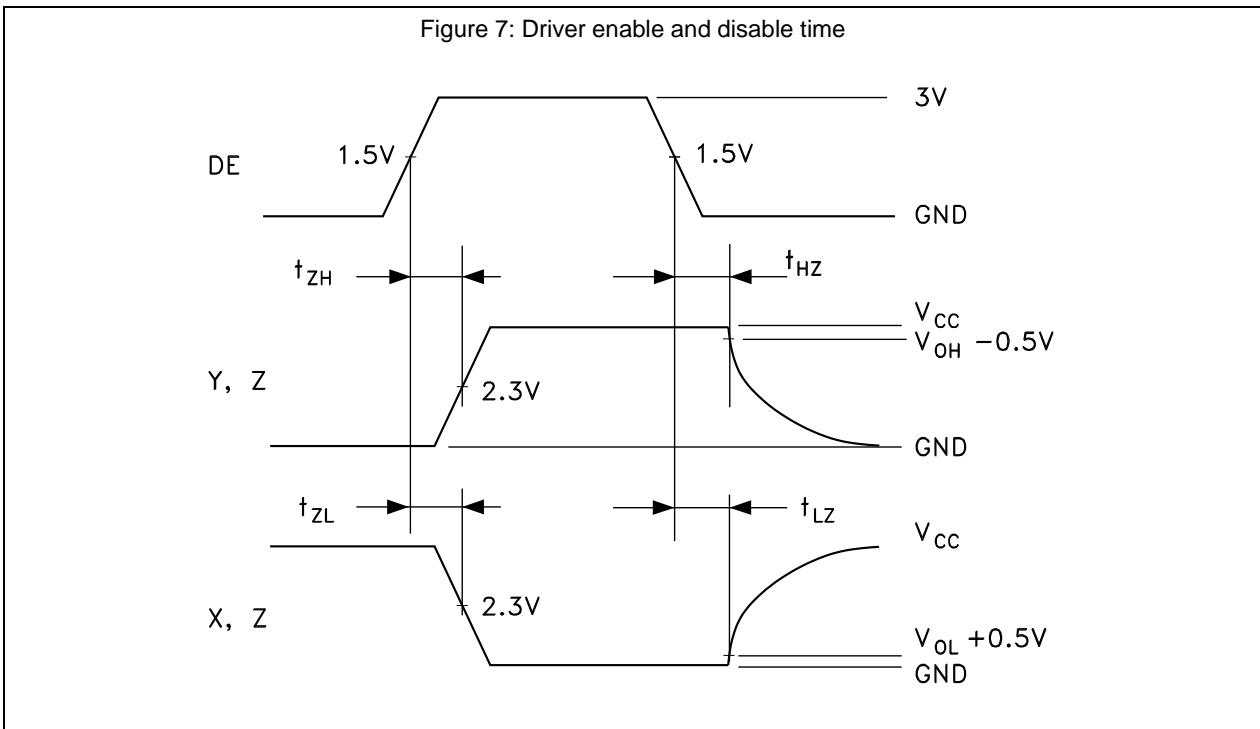
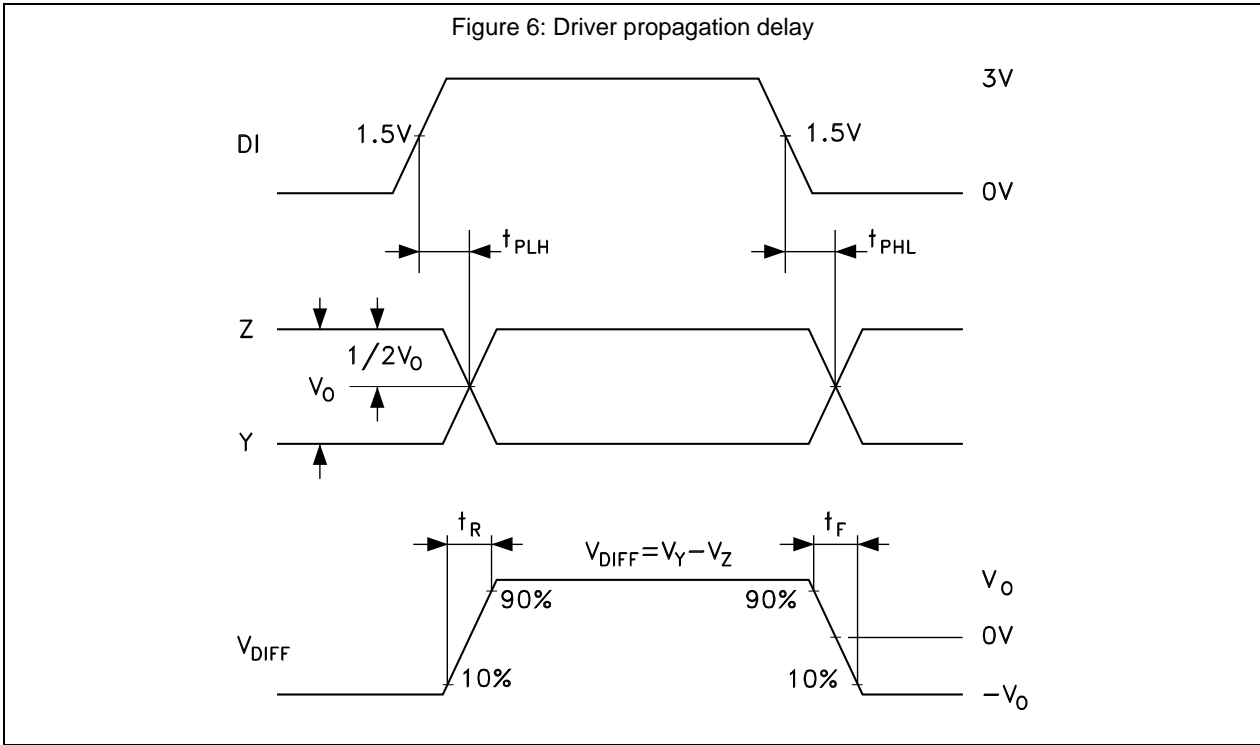

Figure 8: Receiver propagation delay

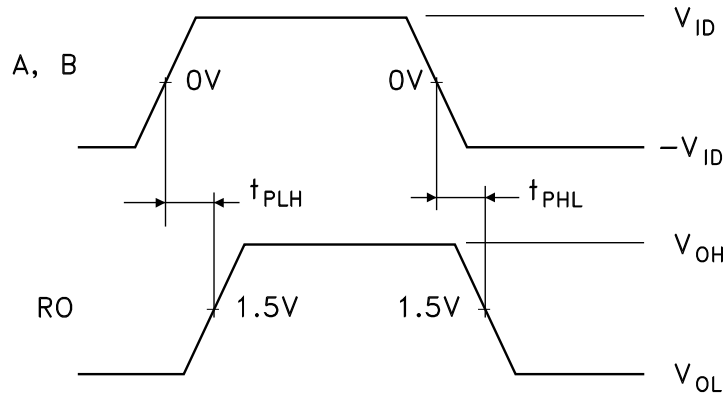

Figure 9: Receiver enable and disable time

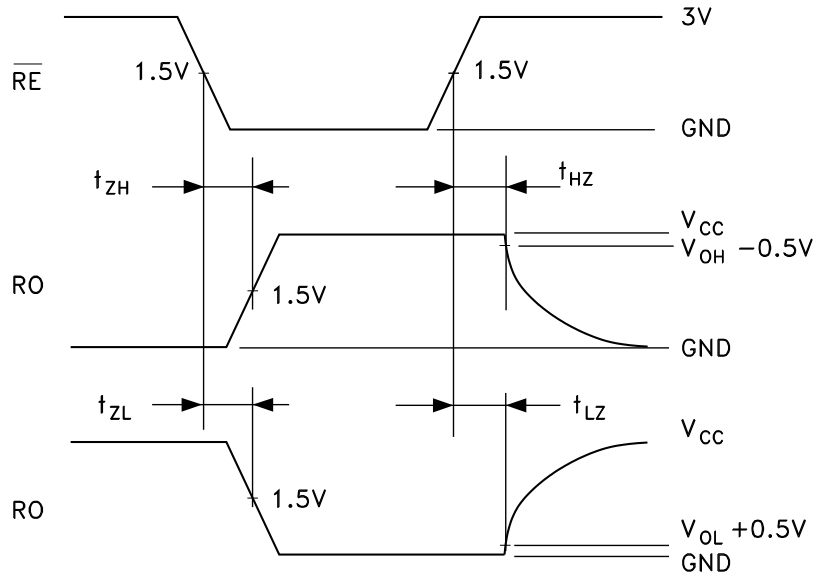

Figure 10: Receiver output current vs. output low voltage

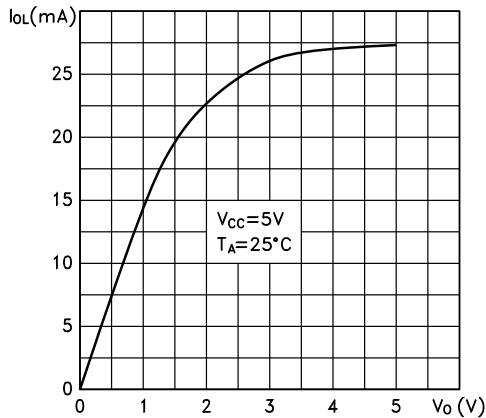

Figure 11: Receiver output current vs. output high voltage

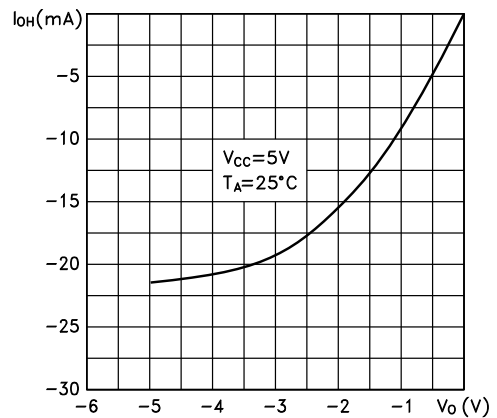

Figure 12: Driver output current vs. output low voltage

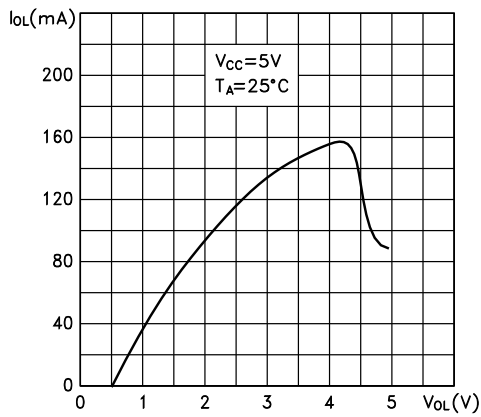

Figure 13: Driver output current vs. output high voltage

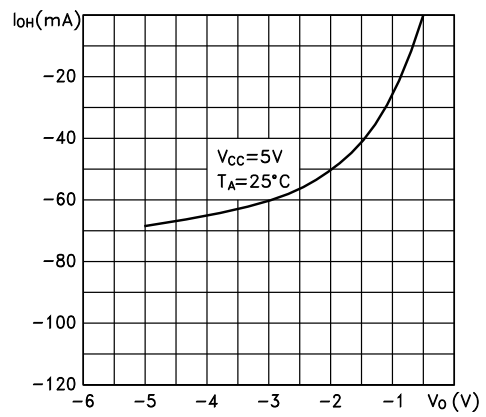

Figure 14: Supply current vs. temperature

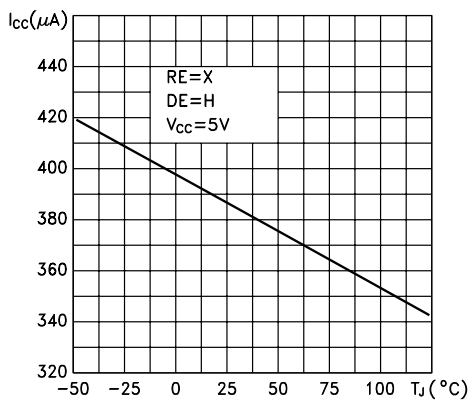

Figure 15: Receiver high level output voltage vs. temperature

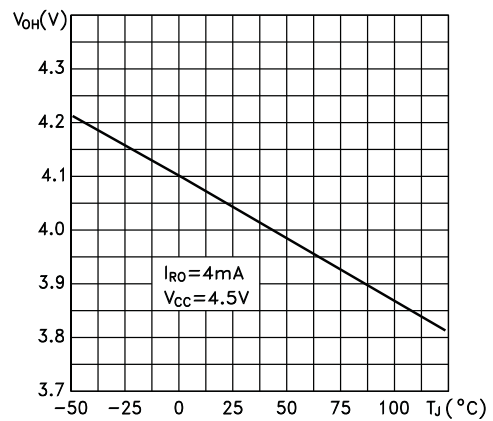

Figure 16: Receiver low level output voltage vs. temperature

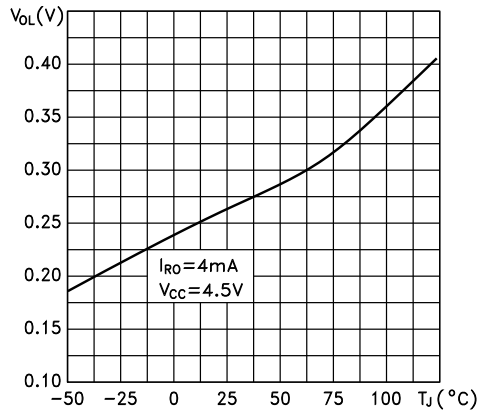
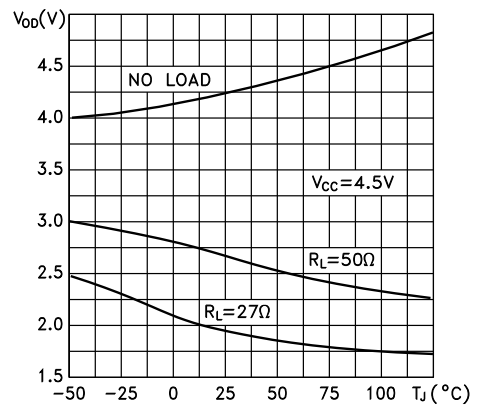

Figure 17: Differential driver output voltage vs. temperature



## 6 Package information

In order to meet environmental requirements, ST offers these devices in different grades of ECOPACK® packages, depending on their level of environmental compliance. ECOPACK® specifications, grade definitions and product status are available at: [www.st.com](http://www.st.com). ECOPACK® is an ST trademark.

### 6.1 SO8 package information

Figure 18: SO8 package outline

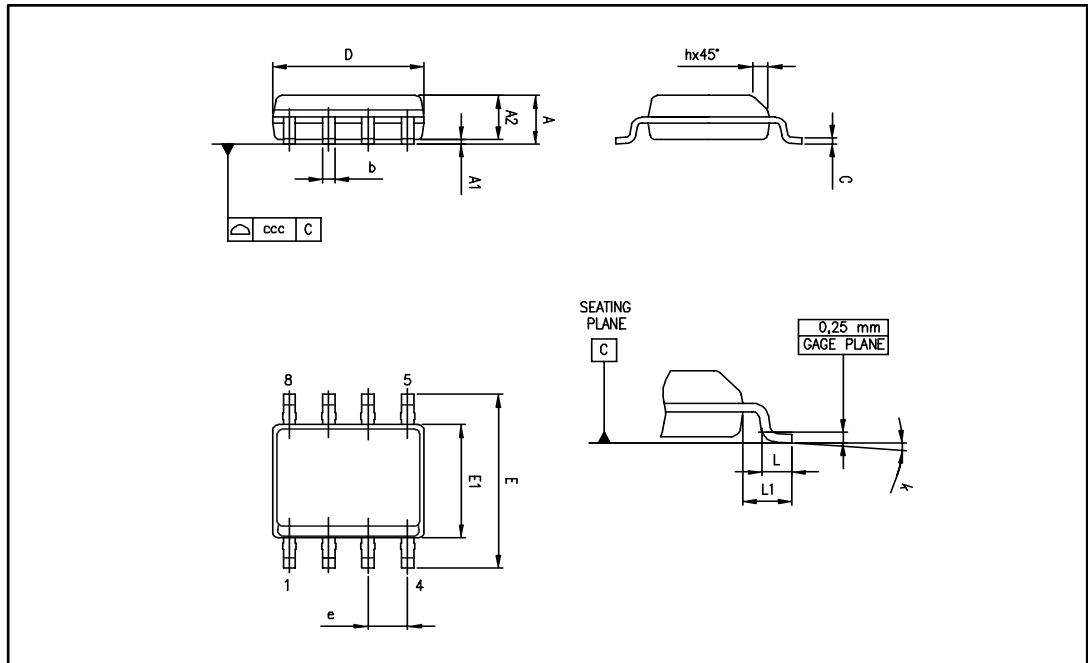
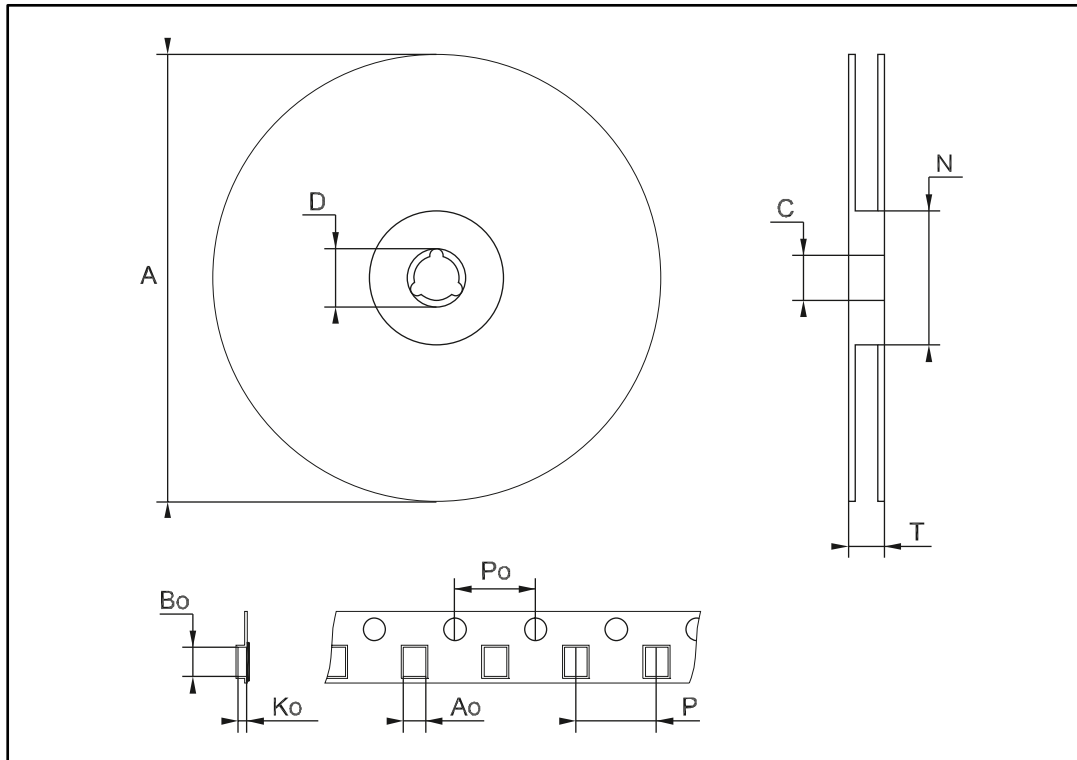

Table 9: SO8 mechanical data

Ref.	Dimensions					
	Millimeters			Inches		
	Min.	Typ.	Max.	Min.	Typ.	Max
A			1.75			0.069
A1	0.10		0.25	0.004		0.010
A2	1.25			0.049		
b	0.28		0.48	0.011		0.019
c	0.17		0.23	0.007		0.010
D	4.80	4.90	5.00	0.189	0.193	0.197
E	5.80	6.00	6.20	0.228	0.236	0.244
E1	3.80	3.90	4.00	0.150	0.154	0.157
e		1.27			0.050	
h	0.25		0.50	0.010		0.020
L	0.40		1.27	0.016		0.050
L1		1.04			0.040	
k	0°		8°	0°		8°
ccc			0.10			0.004

## 6.2 SO8 tape and reel information

Figure 19: SO8 tape and reel outline



1. Drawing not to scale

Table 10: SO8 tape and reel mechanical data

Symbol	Dimensions					
	mm			inch		
	Min.	Typ.	Max.	Min.	Typ.	Max.
A			330			12.992
C	12.8		13.2	0.504		0.519
D	20.2			0.795		
N	60			2.362		
T			22.4			0.882
Ao	8.1	—	8.5	0.319	—	0.335
Bo	5.5		5.9	0.216		0.232
Ko	2.1		2.3	0.082		0.090
Po	3.9		4.1	0.153		0.161
P	7.9		8.1	0.311		0.319

## 7 Ordering information

Table 11: Order code

Order code	Temperature range	Package	Packaging
ST485ERBDR	-40 to 85 °C	SO8 (tape and reel)	2500 parts per reel

## 8 Revision history

Table 12: Document revision history

Date	Revision	Changes
21-Mar-2006	3	Order codes has been updated and new template.
01-Aug-2006	4	Mistake in cover page description 300 mA ==> 300 $\mu$ A.
25-Oct-2006	5	Order codes updated.
02-Dec-2008	6	Modified: device name Table 1 on page 1.
16-Feb-2008	7	Modified Note on page 5.
04-Oct-2016	8	<p>Updated "<i>Features</i>": replaced "allows up to 256 transceivers on the bus" by "64 transceivers".</p> <p><i>Table 6: "DC electrical characteristics"</i>: updated footnote 3</p> <p>Removed DIP package</p> <p>Updated SO8 package</p> <p>Removed "Device summary" table to <i>Section 7: "Ordering information"</i>.</p> <p>Removed obsolete order code ST485ERBN</p>

**IMPORTANT NOTICE – PLEASE READ CAREFULLY**

STMicroelectronics NV and its subsidiaries ("ST") reserve the right to make changes, corrections, enhancements, modifications, and improvements to ST products and/or to this document at any time without notice. Purchasers should obtain the latest relevant information on ST products before placing orders. ST products are sold pursuant to ST's terms and conditions of sale in place at the time of order acknowledgement.

Purchasers are solely responsible for the choice, selection, and use of ST products and ST assumes no liability for application assistance or the design of Purchasers' products.

No license, express or implied, to any intellectual property right is granted by ST herein.

Resale of ST products with provisions different from the information set forth herein shall void any warranty granted by ST for such product.

ST and the ST logo are trademarks of ST. All other product or service names are the property of their respective owners.

Information in this document supersedes and replaces information previously supplied in any prior versions of this document.

© 2016 STMicroelectronics – All rights reserved

## Looking for pricing, stock, or lifecycle information?

Click below to explore more details on WIN SOURCE:

-  [View ST485ERXDR on WIN SOURCE](#)
-  [STMicroelectronics Information](#)

## Optimize Your Supply Chain with WIN SOURCE Solutions

-  Global Sourcing Solution
-  Obsolete Management
-  Cost Control Management
-  Shortage Management
-  Alternative Solution
-  Excess Inventory Management