



**THE DATASHEET OF
ADM2490EBRWZ**



FEATURES

- Isolated, full-duplex RS-485/RS-422 transceiver
- ±8 kV ESD protection on RS-485 input/output pins
- 16 Mbps data rate
- Complies with ANSI TIA/EIA-485-A-1998 and ISO 8482: 1987(E)
- Suitable for 5 V or 3 V operation (V_{DD1})
- High common-mode transient immunity: >25 kV/ μ s
- Receiver has open-circuit, fail-safe design
- 32 nodes on the bus
- Thermal shutdown protection
- Safety and regulatory approvals
 - UL recognition: 5000 V rms isolation voltage for 1 minute per UL 1577
 - VDE certificate of conformity
 - DIN EN 60747-5-2 (VDE 0884-10 Part 2): 2003-01
 - DIN EN 60950 (VDE 0805): 2001-12; EN 60950: 2000
 - $V_{IORM} = 848$ V peak
- Operating temperature range: -40°C to $+105^{\circ}\text{C}$
- Wide body, 16-lead SOIC package

APPLICATIONS

- Isolated RS-485/RS-422 interfaces
- Industrial field networks
- INTERBUS
- Multipoint data transmission systems

GENERAL DESCRIPTION

The ADM2490E is an isolated data transceiver with ± 8 kV ESD protection that is suitable for high speed, full-duplex communication on multipoint transmission lines. It is designed for balanced transmission lines and complies with ANSI TIA/EIA-485-A-1998 and ISO 8482: 1987(E). The device employs Analog Devices, Inc., iCoupler® technology to combine a 2-channel isolator, a three-state differential line driver, and a differential input receiver into a single package.

The differential transmitter outputs and receiver inputs feature electrostatic discharge circuitry that provides protection to ± 8 kV

FUNCTIONAL BLOCK DIAGRAM

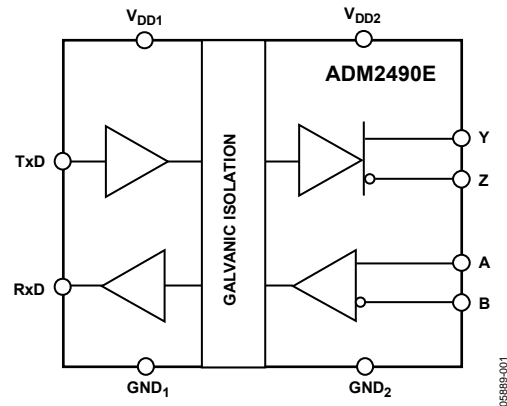

Figure 1.

using the human body model (HBM). The logic side of the device can be powered with either a 5 V or a 3 V supply, whereas the bus side requires an isolated 5 V supply.

The device has current-limiting and thermal shutdown features to protect against output short circuits and situations where bus contention could cause excessive power dissipation.

The ADM2490E is available in a wide body, 16-lead SOIC package and operates over the -40°C to $+105^{\circ}\text{C}$ temperature range.

Rev. A

Information furnished by Analog Devices is believed to be accurate and reliable. However, no responsibility is assumed by Analog Devices for its use, nor for any infringements of patents or other rights of third parties that may result from its use. Specifications subject to change without notice. No license is granted by implication or otherwise under any patent or patent rights of Analog Devices. Trademarks and registered trademarks are the property of their respective owners.

TABLE OF CONTENTS

Features	1	Switching Characteristics	9
Applications.....	1	Typical Performance Characteristics	10
Functional Block Diagram	1	Circuit Description.....	12
General Description	1	Electrical Isolation.....	12
Revision History	2	Truth Tables.....	12
Specifications.....	3	Thermal Shutdown	13
Timing Specifications	4	Fail-Safe Receiver Inputs	13
Package Characteristics	4	Magnetic Field Immunity.....	13
Regulatory Information.....	5	Applications Information	14
Insulation and Safety-Related Specifications.....	5	Isolated Power Supply Circuit	14
VDE 0884-10 Insulation Characteristics.....	5	PCB Layout	14
Absolute Maximum Ratings.....	6	Typical Applications.....	15
ESD Caution.....	6	Outline Dimensions	16
Pin Configuration and Function Descriptions.....	7	Ordering Guide	16
Test Circuits.....	8		

REVISION HISTORY

8/08—Rev. 0 to Rev. A

Changes to Regulatory Approval Status Throughout.....	1
Changed VDE 0884 to VDE 0884-10 Throughout	1
Changes to Table 5.....	5
Changes to Table 8.....	6
Changes to Figure 9.....	9
Changes to <i>i</i> Coupler Technology Section	12
Changes to Magnetic Field Immunity Section	13
Changes to Isolated Power Supply Circuit Section	14
Changes to Figure 25.....	14
Added Typical Applications Section	15
Updated Outline Dimensions	16
Changes to Ordering Guide	16

10/06—Revision 0: Initial Version

SPECIFICATIONS

All voltages are relative to their respective ground; $2.7 \leq V_{DD1} \leq 5.5 \text{ V}$, $4.5 \text{ V} \leq V_{DD2} \leq 5.5 \text{ V}$. All minimum/maximum specifications apply over the entire recommended operation range, unless otherwise noted. All typical specifications are at $T_A = 25^\circ\text{C}$, $V_{DD1} = V_{DD2} = 5.0 \text{ V}$, unless otherwise noted.

Table 1.

Parameter	Symbol	Min	Typ	Max	Unit	Test Conditions
SUPPLY CURRENT						
Power Supply Current, Logic Side						
TxD/RxD Data Rate < 2 Mbps	I_{DD1}			3.0	mA	$2.7 \text{ V} \leq V_{DD1} \leq 5.5 \text{ V}$, unloaded
TxD/RxD Data Rate = 16 Mbps	I_{DD1}			6	mA	100 Ω load between Y and Z
Power Supply Current, Bus Side						
TxD/RxD Data Rate < 2 Mbps	I_{DD2}			4.0	mA	$2.7 \text{ V} \leq V_{DD1} \leq 5.5 \text{ V}$, unloaded
TxD/RxD Data Rate = 16 Mbps	I_{DD2}			60	mA	100 Ω load between Y and Z
DRIVER						
Differential Outputs						
Differential Output Voltage, Loaded	$ V_{OD2} $	2.0		5.0	V	$R_L = 50 \Omega$ (RS-422), see Figure 3
		1.5		5.0	V	$R_L = 27 \Omega$ (RS-485), see Figure 3
	$ V_{OD4} $	1.5		5.0	V	$-7 \text{ V} \leq V_{TEST1} \leq +12 \text{ V}$, see Figure 4
$\Delta V_{OD} $ for Complementary Output States	$\Delta V_{OD} $			0.2	V	$R_L = 54 \Omega$ or 100 Ω , see Figure 3
Common-Mode Output Voltage	V_{OC}			3.0	V	$R_L = 54 \Omega$ or 100 Ω , see Figure 3
$\Delta V_{OC} $ for Complementary Output States	$\Delta V_{OC} $			0.2	V	$R_L = 54 \Omega$ or 100 Ω , see Figure 3
Short-Circuit Output Current	I_{OS}			200	mA	
Logic Inputs						
Input Threshold Low	V_{IL}	$0.25 \times V_{DD1}$			V	
Input Threshold High	V_{IH}			$0.7 \times V_{DD1}$	V	
TxD Input Current	I_{TXD}	-10	+0.01	+10	μA	
RECEIVER						
Differential Inputs						
Differential Input Threshold Voltage	V_{TH}	-0.2		+0.2	V	
Input Voltage Hysteresis	V_{HYS}		70		mV	$V_{OC} = 0 \text{ V}$
Input Current (A, B)	I_i			1.0	mA	$V_{OC} = 12 \text{ V}$
		-0.8			mA	$V_{OC} = -7 \text{ V}$
Line Input Resistance	R_{IN}	12			k Ω	
Logic Outputs						
Output Voltage Low	V_{OLRXD}		0.2	0.4	V	$I_{ORxD} = 1.5 \text{ mA}$, $V_A - V_B = -0.2 \text{ V}$
Output Voltage High	V_{OHRxD}	$V_{DD1} - 0.3$	$V_{DD1} - 0.2$		V	$I_{ORxD} = -1.5 \text{ mA}$, $V_A - V_B = 0.2 \text{ V}$
Short-Circuit Current				100	mA	
COMMON-MODE TRANSIENT IMMUNITY¹						
		25			kV/ μs	$V_{CM} = 1 \text{ kV}$, transient magnitude = 800 V

¹ CM is the maximum common-mode voltage slew rate that can be sustained while maintaining specification-compliant operation. V_{CM} is the common-mode potential difference between the logic and bus sides. The transient magnitude is the range over which the common-mode is slewed. The common-mode voltage slew rates apply to both rising and falling common-mode voltage edges.

ADM2490E

TIMING SPECIFICATIONS

$T_A = -40^\circ\text{C}$ to $+85^\circ\text{C}$.

Table 2.

Parameter	Symbol	Min	Typ	Max	Unit	Test Conditions
DRIVER						
Maximum Data Rate		16			Mbps	
Propagation Delay	t_{PLH}, t_{PHL}		45	60	ns	$R_L = 54\ \Omega, C_{L1} = C_{L2} = 100\ \text{pF}$, see Figure 6 and Figure 8
Pulse Width Distortion, $PWD = t_{PYLH} - t_{PYHL} , PWD = t_{PZLH} - t_{PZHL} $	t_{PWD}, t_{PWD}			7	ns	$R_L = 54\ \Omega, C_{L1} = C_{L2} = 100\ \text{pF}$, see Figure 6 and Figure 8
Single-Ended Output Rise/Fall Times	t_R, t_F			20	ns	$R_L = 54\ \Omega, C_{L1} = C_{L2} = 100\ \text{pF}$, see Figure 6 and Figure 8
RECEIVER						
Propagation Delay	t_{PLH}, t_{PHL}			60	ns	$C_L = 15\ \text{pF}$, see Figure 7 and Figure 9
Pulse Width Distortion, $PWD = t_{PLH} - t_{PHL} $	t_{PWD}			10	ns	$C_L = 15\ \text{pF}$, see Figure 7 and Figure 9

$T_A = -40^\circ\text{C}$ to $+105^\circ\text{C}$.

Table 3.

Parameter	Symbol	Min	Typ	Max	Unit	Test Conditions
DRIVER						
Maximum Data Rate		10			Mbps	
Propagation Delay	$t_{PYLH}, t_{PYHL}, t_{PZLH}, t_{PZHL}$		45	60	ns	$R_L = 54\ \Omega, C_{L1} = C_{L2} = 100\ \text{pF}$, see Figure 6 and Figure 8
Pulse Width Distortion, $PWD = t_{PYLH} - t_{PYHL} , PWD = t_{PZLH} - t_{PZHL} $	t_{PWD}, t_{PWD}			9	ns	$R_L = 54\ \Omega, C_{L1} = C_{L2} = 100\ \text{pF}$, see Figure 6 and Figure 8
Single-Ended Output Rise/Fall Time	t_R, t_F			27	ns	$R_L = 54\ \Omega, C_{L1} = C_{L2} = 100\ \text{pF}$, see Figure 6 and Figure 8
RECEIVER						
Propagation Delay	t_{PLH}, t_{PHL}			60	ns	$C_L = 15\ \text{pF}$, see Figure 7 and Figure 9
Pulse Width Distortion, $PWD = t_{PLH} - t_{PHL} $	t_{PWD}			10	ns	$C_L = 15\ \text{pF}$, see Figure 7 and Figure 9

PACKAGE CHARACTERISTICS

Table 4.

Parameter	Symbol	Min	Typ	Max	Unit	Test Conditions
Resistance (Input to Output) ¹	R_{I-O}		10^{12}		Ω	
Capacitance (Input to Output) ¹	C_{I-O}		3		pF	$f = 1\ \text{MHz}$
Input Capacitance ²	C_i		4		pF	
Input IC Junction-to-Case Thermal Resistance	θ_{JCI}		33		$^\circ\text{C}/\text{W}$	Thermocouple located at center of package underside
Output IC Junction-to-Case Thermal Resistance	θ_{JCO}		28		$^\circ\text{C}/\text{W}$	

¹ Device considered a 2-terminal device: Pin 1, Pin 2, Pin 3, Pin 4, Pin 5, Pin 6, Pin 7, and Pin 8 are shorted together and Pin 9, Pin 10, Pin 11, Pin 12, Pin 13, Pin 14, Pin 15, and Pin 16 are shorted together.

² Input capacitance is from any input data pin to ground.

REGULATORY INFORMATION

Table 5. ADM2490E Approvals

Organization	Approval Type	Notes
UL	Recognized under the Component Recognition Program of Underwriters Laboratories, Inc.	In accordance with UL 1577, each ADM2490E is proof tested by applying an insulation test voltage ≥ 6000 V rms for 1 second (current leakage detection limit = 10 μ A).
VDE	Certified according to DIN EN 60747-5-2 (VDE 0884-10 Part 2): 2003-01, DIN EN 60950 (VDE 0805): 2001-12; EN 60950: 2000	In accordance with DIN EN 60747-5-2, each ADM2490E is proof tested by applying an insulation test voltage ≥ 1590 V peak for 1 second (partial discharge detection limit = 5 pC).

INSULATION AND SAFETY-RELATED SPECIFICATIONS

Table 6.

Parameter	Symbol	Value	Unit	Conditions
Rated Dielectric Insulation Voltage		5000	V rms	1 minute duration
Minimum External Air Gap (Clearance)	L(I01)	7.45	mm min	Measured from input terminals to output terminals, shortest distance through air
Minimum External Tracking (Creepage)	L(I02)	8.1	mm min	Measured from input terminals to output terminals, shortest distance along body
Minimum Internal Gap (Internal Clearance)		0.017	mm min	Insulation distance through insulation
Tracking Resistance (Comparative Tracking Index)	CTI	>175	V	DIN IEC 112/VDE 0303 Part 1
Isolation Group		IIIa		Material Group (DIN VDE 0110, 1/89)

VDE 0884-10 INSULATION CHARACTERISTICS

This isolator is suitable for basic electrical isolation only within the safety limit data. Maintenance of the safety data must be ensured by means of protective circuits.

An asterisk (*) on a package denotes VDE 0884-10 approval for 848 V peak working voltage.

Table 7.

Description	Symbol	Characteristic	Unit
Installation Classification per DIN VDE 0110 for Rated Mains Voltage		I to IV	
≤ 300 V rms		I to II	
≤ 450 V rms		I to II	
≤ 600 V rms		40/105/21	
Climatic Classification		2	
Pollution Degree (DIN VDE 0110, see Table 1)		848	V peak
Maximum Working Insulation Voltage	V_{IORM}	1590	V peak
Input-to-Output Test Voltage, Method b1	V_{PR}		
$V_{IORM} \times 1.875 = V_{PR}$, 100% Production Tested, $t_m = 1$ sec, Partial Discharge < 5 pC			
Input-to-Output Test Voltage, Method a			
After Environmental Tests, Subgroup 1		1357	V peak
$V_{IORM} \times 1.6 = V_{PR}$, $t_m = 60$ sec, Partial Discharge < 5 pC			
After Input and/or Safety Test, Subgroup 2/3			
$V_{IORM} \times 1.2 = V_{PR}$, $t_m = 60$ sec, Partial Discharge < 5 pC	V_{PR}	1018	V peak
Highest Allowable Overvoltage (Transient Overvoltage, $t_{TR} = 10$ sec)	V_{TR}	6000	V peak
Safety-Limiting Values (Maximum Value Allowed in the Event of a Failure; see Figure 16)			
Case Temperature	T_s	150	$^{\circ}$ C
Input Current	$I_{S, INPUT}$	265	mA
Output Current	$I_{S, OUTPUT}$	335	mA
Insulation Resistance at $T_s, V_{IO} = 500$ V	R_s	$>10^9$	Ω

ADM2490E

ABSOLUTE MAXIMUM RATINGS

$T_A = 25^\circ\text{C}$, unless otherwise noted. Each voltage is relative to its respective ground.

Table 8.

Parameter	Rating
Storage Temperature Range	-55°C to $+150^\circ\text{C}$
Ambient Operating Temperature Range	-40°C to $+105^\circ\text{C}$
V_{DD1}	-0.5 V to $+7\text{ V}$
V_{DD2}	-0.5 V to $+6\text{ V}$
Logic Input Voltages	-0.5 V to $V_{DD1} + 0.5\text{ V}$
Bus Terminal Voltages	-9 V to $+14\text{ V}$
Logic Output Voltages	-0.5 V to $V_{DD1} + 0.5\text{ V}$
Average Output Current, per Pin	$\pm 35\text{ mA}$
ESD (Human Body Model) on A, B, Y, and Z Pins	$\pm 8\text{ kV}$
θ_{JA} Thermal Impedance	60°C/W

Stresses above those listed under Absolute Maximum Ratings may cause permanent damage to the device. This is a stress rating only; functional operation of the device at these or any other conditions above those indicated in the operational section of this specification is not implied. Exposure to absolute maximum rating conditions for extended periods may affect device reliability.

Absolute maximum ratings apply individually only, not in combination.

ESD CAUTION



ESD (electrostatic discharge) sensitive device. Charged devices and circuit boards can discharge without detection. Although this product features patented or proprietary protection circuitry, damage may occur on devices subjected to high energy ESD. Therefore, proper ESD precautions should be taken to avoid performance degradation or loss of functionality.

PIN CONFIGURATION AND FUNCTION DESCRIPTIONS

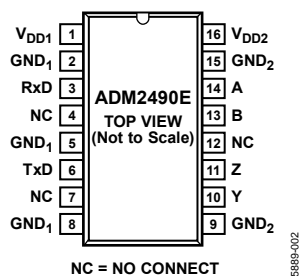

Figure 2. Pin Configuration

Table 9. Pin Function Descriptions

Pin No.	Mnemonic	Description
1	V _{DD1}	Power Supply (Logic Side). Decoupling capacitor to GND ₁ required; capacitor value should be between 0.01 μF and 0.1 μF.
2, 5, 8	GND ₁	Ground (Logic Side).
3	RxD	Receiver Output.
4, 7, 12	NC	No Connect. These pins must be left floating.
6	TxD	Transmit Data.
9, 15	GND ₂	Ground (Bus Side).
10	Y	Driver Noninverting Output.
11	Z	Driver Inverting Output.
13	B	Receiver Inverting Input.
14	A	Receiver Noninverting Input.
16	V _{DD2}	Power Supply (Bus Side). Decoupling capacitor to GND ₂ required; capacitor value should be between 0.01 μF and 0.1 μF.

TEST CIRCUITS

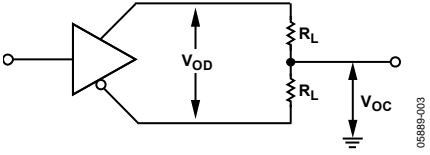

Figure 3. Driver Voltage Measurement

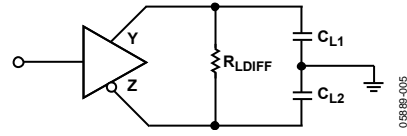

Figure 6. Driver Propagation Delay

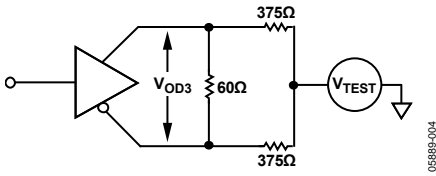

Figure 4. Driver Voltage Measurement

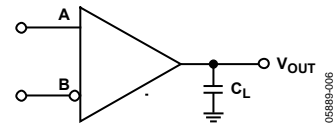

Figure 7. Receiver Propagation Delay

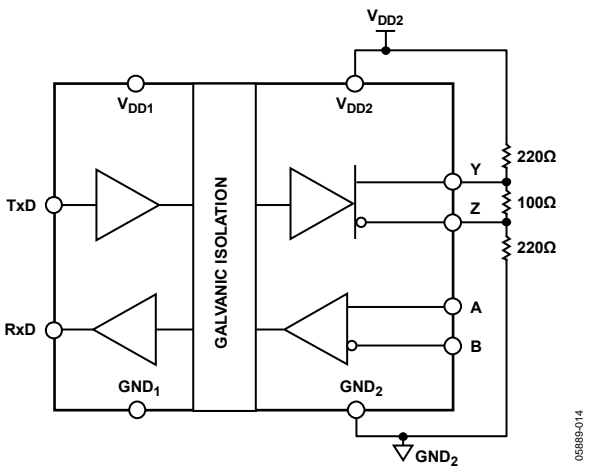

Figure 5. Supply-Current Measurement Test Circuit (See Figure 10 and Figure 11)

SWITCHING CHARACTERISTICS

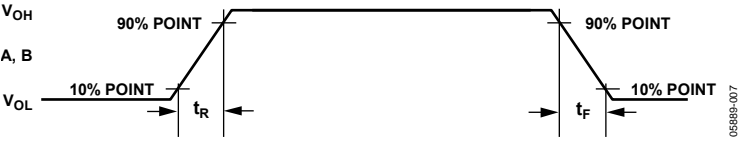
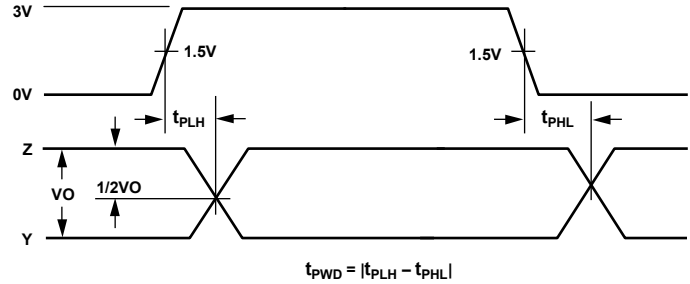

Figure 8. Driver Propagation Delay, Rise/Fall Timing

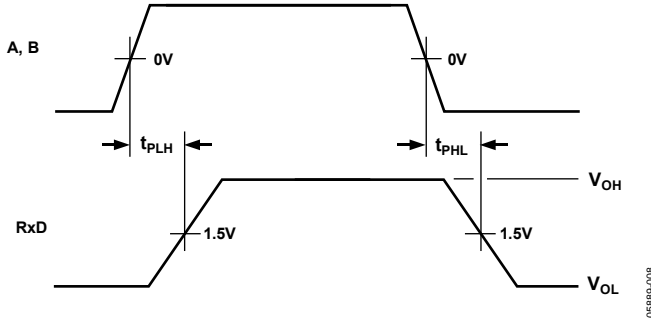

Figure 9. Receiver Propagation Delay

TYPICAL PERFORMANCE CHARACTERISTICS

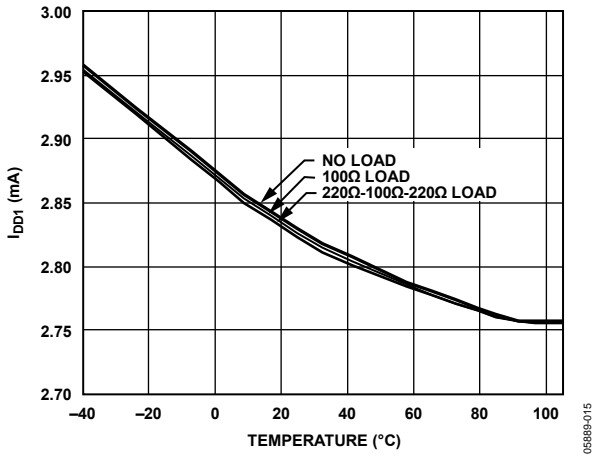

Figure 10. I_{DD1} Supply Current vs. Temperature (See Figure 5)

05889-015

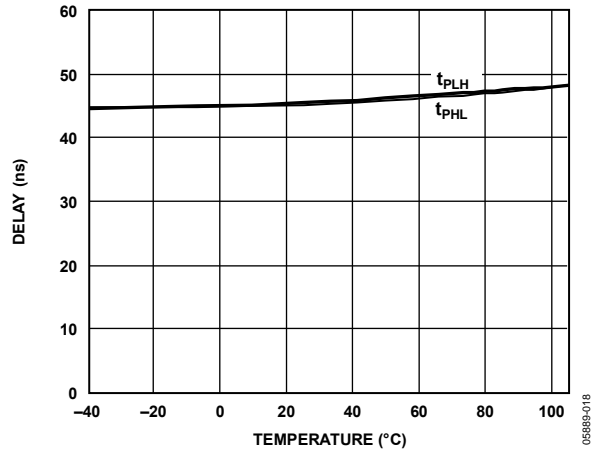

Figure 13. Receiver Propagation Delay vs. Temperature

05889-018

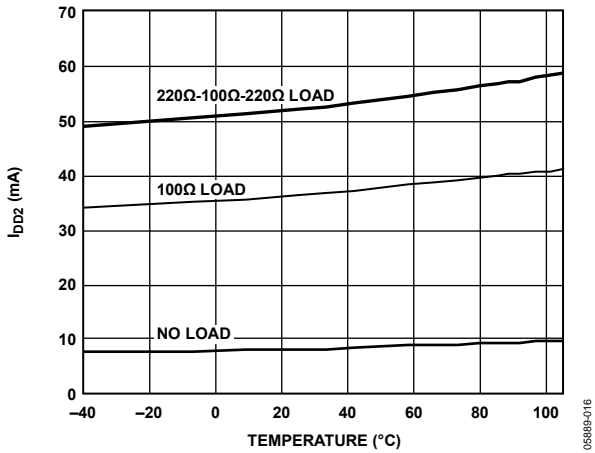

Figure 11. I_{DD2} Supply Current vs. Temperature (See Figure 5)

05889-016

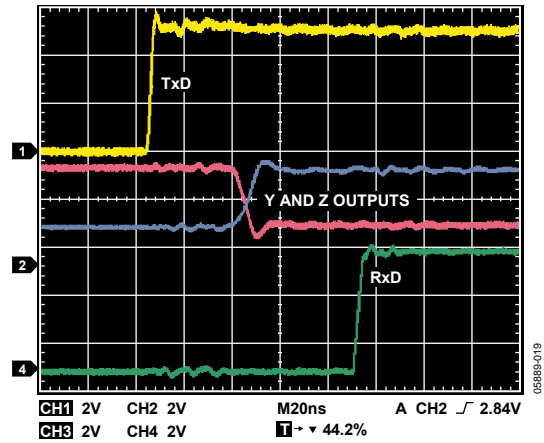

Figure 14. Driver/Receiver Propagation Delay, Low to High ($R_{LDIFF} = 54 \Omega$, $C_{L1} = C_{L2} = 100 \text{ pF}$)

05889-019

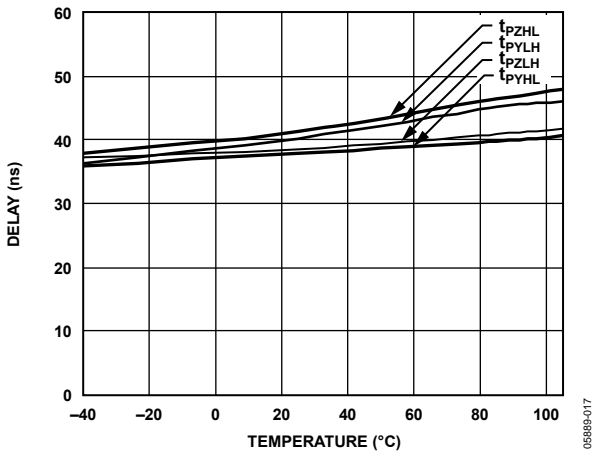

Figure 12. Driver Propagation Delay vs. Temperature

05889-017

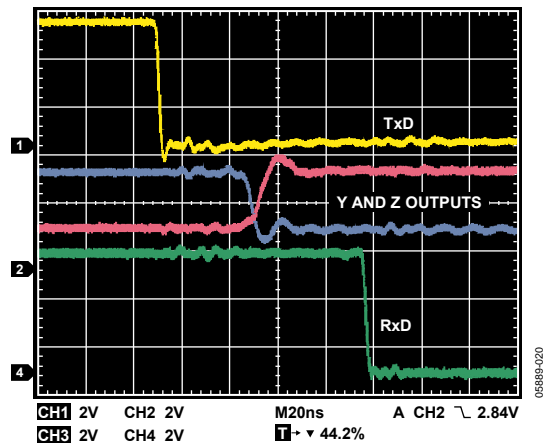

Figure 15. Driver/Receiver Propagation Delay, High to Low ($R_{LDIFF} = 54 \Omega$, $C_{L1} = C_{L2} = 100 \text{ pF}$)

05889-020

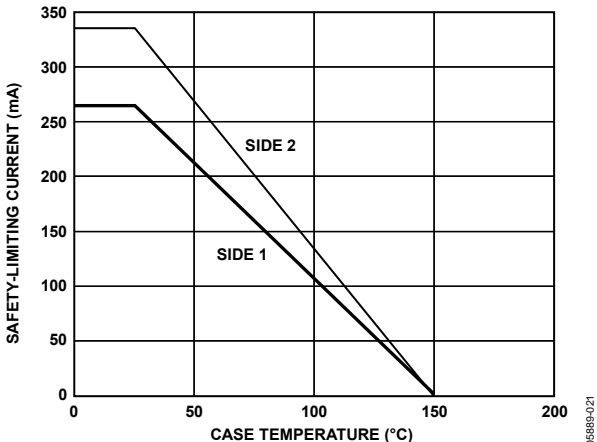

Figure 16. Thermal Derating Curve, Dependence of Safety-Limiting Values with Case Temperature per VDE 0884-10

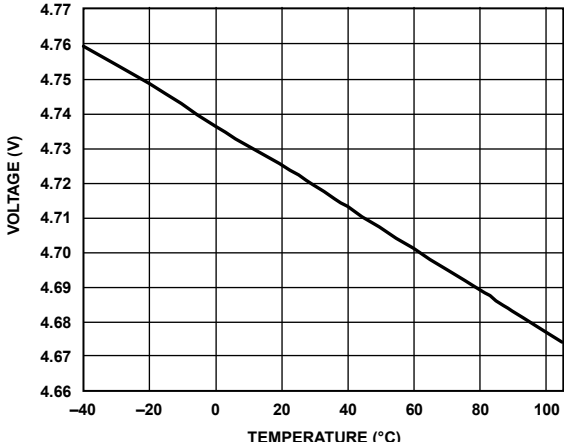

Figure 19. Receiver Output High Voltage vs. Temperature, $I_{RXD} = -4 \text{ mA}$

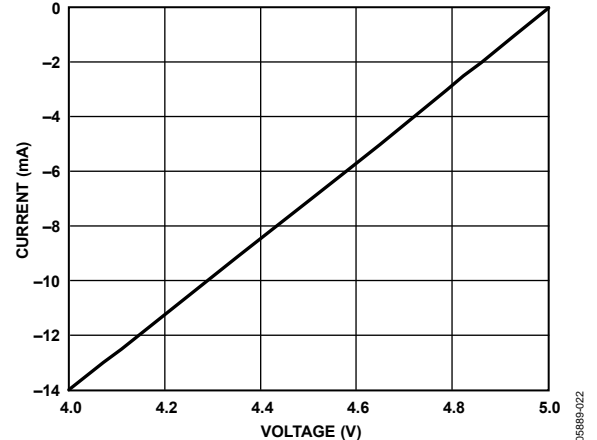

Figure 17. Output Current vs. Receiver Output High Voltage

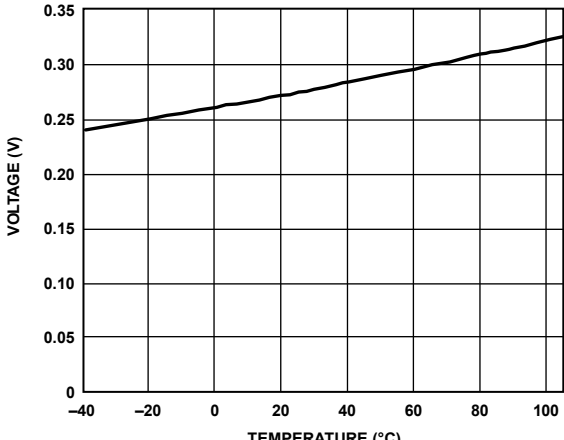

Figure 20. Receiver Output Low Voltage vs. Temperature, $I_{RXD} = -4 \text{ mA}$

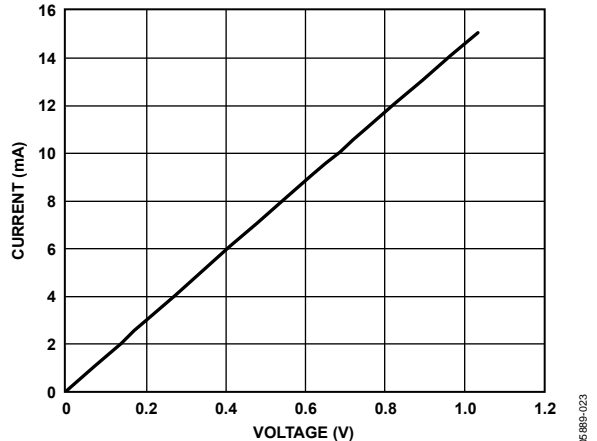

Figure 18. Output Current vs. Receiver Output Low Voltage

CIRCUIT DESCRIPTION

ELECTRICAL ISOLATION

In the ADM2490E, electrical isolation is implemented on the logic side of the interface. Therefore, the part has two main sections: a digital isolation section and a transceiver section (see Figure 21). The driver input signal, which is applied to the TxD pin and referenced to logic ground (GND_1), is coupled across an isolation barrier to appear at the transceiver section referenced to isolated ground (GND_2). Similarly, the receiver input, which is referenced to isolated ground in the transceiver section, is coupled across the isolation barrier to appear at the RxD pin referenced to logic ground.

iCoupler Technology

The digital signals transmit across the isolation barrier using iCoupler technology. This technique uses chip scale transformer windings to couple the digital signals magnetically from one side of the barrier to the other. Digital inputs are encoded into waveforms that are capable of exciting the primary transformer winding. At the secondary winding, the induced waveforms are decoded into the binary value that was originally transmitted.

Positive and negative logic transitions at the input cause narrow pulses (~ 1 ns) to be sent to the decoder via the transformer. The decoder is bistable and is, therefore, either set or reset by the pulses, indicating input logic transitions. In the absence of logic transitions at the input for more than ~ 1 μ s, a periodic set of refresh pulses indicative of the correct input state are sent to ensure dc correctness at the output. If the decoder receives no internal pulses for more than about 5 μ s, the input side is assumed to be unpowered or nonfunctional, in which case the output is forced to a default state (see Table 12).

TRUTH TABLES

The truth tables in this section use the abbreviations shown in Table 10.

Table 10. Truth Table Abbreviations

Abbreviation	Description
H	High level
I	Indeterminate
L	Low level
X	Irrelevant

Table 11. Transmitting

Supply Status		Input	Outputs	
V_{DD1}	V_{DD2}	TxD	Y	Z
On	On	H	H	L
On	On	L	L	H

Table 12. Receiving

Supply Status		Inputs	Output
V_{DD1}	V_{DD2}	A – B (V)	RxD
On	On	>0.2	H
On	On	<-0.2	L
On	On	$-0.2 < A - B < +0.2$	I
On	On	Inputs open	H
On	Off	X	H
Off	On	X	H
Off	Off	X	L

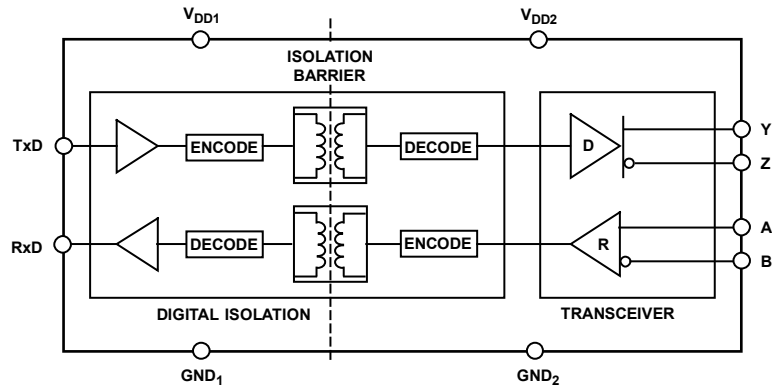

Figure 21. ADM2490E Digital Isolation and Transceiver Sections

THERMAL SHUTDOWN

The ADM2490E contains thermal-shutdown circuitry that protects the part from excessive power dissipation during fault conditions. Shorting the driver outputs to a low impedance source can result in high driver currents. The thermal sensing circuitry detects the increase in die temperature under this condition and disables the driver outputs. This circuitry is designed to disable the driver outputs when a die temperature of 150°C is reached. As the device cools, the drivers are re-enabled at a temperature of 140°C.

FAIL-SAFE RECEIVER INPUTS

The receiver inputs include a fail-safe feature that guarantees a logic high on the RxD pin when the A and B inputs are floating or open-circuited.

MAGNETIC FIELD IMMUNITY

The limitation on the magnetic field immunity of the iCoupler is set by the condition in which an induced voltage in the receiving coil of the transformer is large enough to either falsely set or reset the decoder. The following analysis defines the conditions under which this may occur. The 3 V operating condition of the ADM2490E is examined because it represents the most susceptible mode of operation.

The pulses at the transformer output have an amplitude greater than 1 V. The decoder has a sensing threshold of about 0.5 V, thus establishing a 0.5 V margin in which induced voltages can be tolerated.

The voltage induced across the receiving coil is given by

$$V = \left(\frac{-d\beta}{dt} \right) \sum \pi r_n^2; n = 1, 2, \dots, N$$

where:

β is the magnetic flux density (gauss).

N is the number of turns in the receiving coil.

r_n is the radius of the n^{th} turn in the receiving coil (cm).

Given the geometry of the receiving coil and an imposed requirement that the induced voltage is, at most, 50% of the 0.5 V margin at the decoder, a maximum allowable magnetic field can be determined using Figure 22.

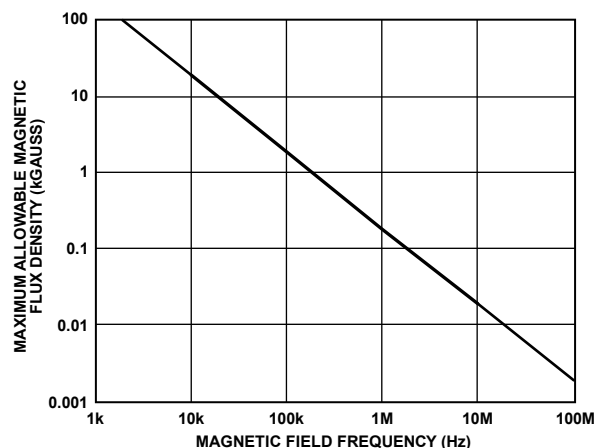

Figure 22. Maximum Allowable External Magnetic Flux Density

For example, at a magnetic field frequency of 1 MHz, the maximum allowable magnetic field of 0.2 kgauss induces a voltage of 0.25 V at the receiving coil. This is about 50% of the sensing threshold and does not cause a faulty output transition. Similarly, if such an event occurs during a transmitted pulse and is the worst-case polarity, it reduces the received pulse from >1.0 V to 0.75 V, still well above the 0.5 V sensing threshold of the decoder.

Figure 23 shows the magnetic flux density values in terms of more familiar quantities, such as maximum allowable current flow at given distances away from the ADM2490E transformers.

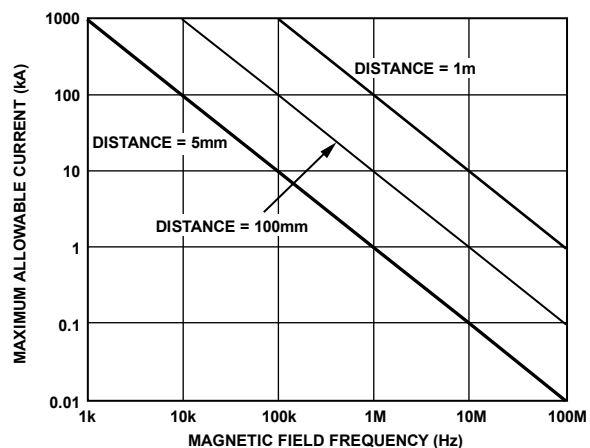

Figure 23. Maximum Allowable Current for Various Current-to-ADM2490E Spacings

With combinations of strong magnetic field and high frequency, any loops formed by PCB traces can induce error voltages large enough to trigger the thresholds of succeeding circuitry. Care should be taken in the layout of such traces to avoid this possibility.

APPLICATIONS INFORMATION

ISOLATED POWER SUPPLY CIRCUIT

The ADM2490E requires isolated power capable of 5 V at up to approximately 65 mA (this current is dependent on the data rate and termination resistors used) to be supplied between the V_{DD2} and the GND_2 pins. A transformer driver circuit with a center-tapped transformer and LDO can be used to generate the isolated 5 V supply, as shown in Figure 25. The center-tapped transformer provides electrical isolation of the 5 V power supply. The primary winding of the transformer is excited with a pair of square waveforms that are 180° out of phase with each other. A pair of Schottky diodes and a smoothing capacitor are used to create a rectified signal from the secondary winding. The ADP3330 linear voltage regulator provides a regulated power supply to the bus-side circuitry (V_{DD2}) of the ADM2490E.

PCB LAYOUT

The ADM2490E isolated RS-485 transceiver requires no external interface circuitry for the logic interfaces. Power supply bypassing is required at the input and output supply pins (see Figure 24). Bypass capacitors are conveniently connected between Pin 1 and Pin 2 for V_{DD1} and between Pin 15 and Pin 16 for V_{DD2} . The capacitor value should be between 0.01 μF and 0.1 μF . The total

lead length between both ends of the capacitor and the input power-supply pin should not exceed 20 mm. Bypassing between Pin 1 and Pin 8 and between Pin 9 and Pin 16 should also be considered unless the ground pair on each package side is connected close to the package.

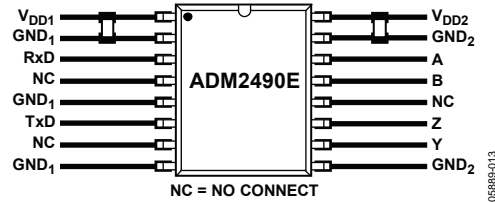

Figure 24. Recommended Printed Circuit Board Layout

In applications involving high common-mode transients, care should be taken to ensure that board coupling across the isolation barrier is minimized. Furthermore, the board layout should be designed such that any coupling that does occur equally affects all pins on a given component side. Failure to ensure this could cause voltage differentials between pins exceeding the absolute maximum ratings of the device, thereby leading to latch-up or permanent damage.

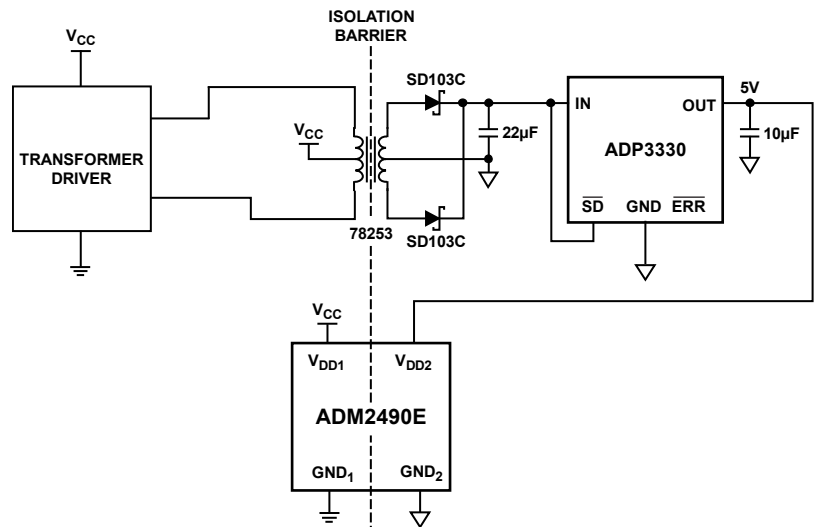
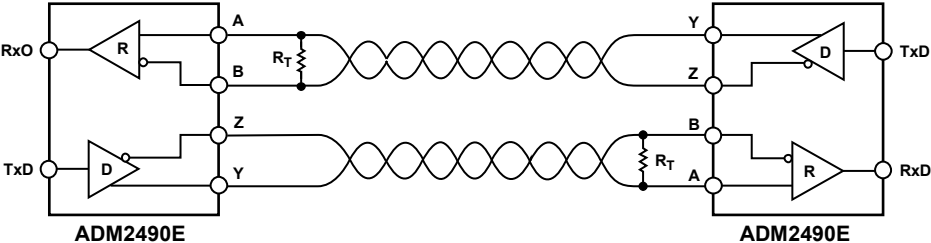

Figure 25. Isolated Power-Supply Circuit

TYPICAL APPLICATIONS

The ADM2490E transceiver is designed for point-to-point transmission lines. Figure 26 shows a full-duplex point-to-point application. To minimize reflections, terminate the line at the receiver end with a termination resistor. The value of the termination resistor should be equal to the characteristic impedance of the cable.



NOTES
1. R_T IS EQUAL TO THE CHARACTERISTIC IMPEDANCE OF THE CABLE.

Figure 26. Full-Duplex Point-to-Point Application

056889-026

OUTLINE DIMENSIONS

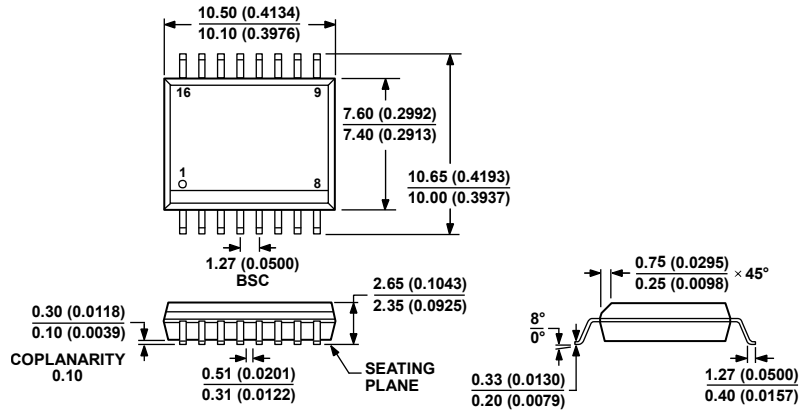

COMPLIANT TO JEDEC STANDARDS MS-013-AA
 CONTROLLING DIMENSIONS ARE IN MILLIMETERS; INCH DIMENSIONS
 (IN PARENTHESES) ARE ROUNDED-OFF MILLIMETER EQUIVALENTS FOR
 REFERENCE ONLY AND ARE NOT APPROPRIATE FOR USE IN DESIGN.

Figure 27. 16-Lead Standard Small Outline Package [SOIC_W]
 Wide Body
 (RW-16)

Dimensions shown in millimeters and (inches)

032707-B

ORDERING GUIDE

Model	Temperature Range	Package Description	Package Option
ADM2490EBRWZ ¹	-40°C to +105°C	16-Lead Standard Small Outline Package [SOIC_W]	RW-16
ADM2490EBRWZ-REEL7 ¹	-40°C to +105°C	16-Lead Standard Small Outline Package [SOIC_W]	RW-16

¹ Z = RoHS Compliant Part.

Looking for pricing, stock, or lifecycle information?

Click below to explore more details on WIN SOURCE:

⊖ [View ADM2490EBRWZ on WIN SOURCE](#)

⊖ [Analog Devices Inc. Information](#)

Optimize Your Supply Chain with WIN SOURCE Solutions

- ✓ Global Sourcing Solution
- ✓ Obsolete Management
- ✓ Cost Control Management
- ✓ Shortage Management
- ✓ Alternative Solution
- ✓ Excess Inventory Management