



**THE DATASHEET OF
ADM2486BRWZ**



FEATURES

- Half-duplex, isolated RS-485 transceiver
- PROFIBUS® compliant
- ANSI EIA/TIA 485-A and ISO 8482: 1987(E) compliant
- 20 Mbps data rate
- 5 V or 3 V operation (V_{DD1})
- High common-mode transient immunity: >25 kV/ μ s
- Isolated DE status output
- Receiver open-circuit, fail-safe design
- Thermal shutdown protection
- 50 nodes on bus
- Safety and regulatory approvals
 - UL recognition—2500 V_{rms} for 1 minute per UL 1577
 - CSA Component Acceptance Notice #5A
 - IEC 609501 800 V_{rms} (basic), 400 V_{rms} (reinforced)
 - VDE Certificate of Conformity
 - DIN V VDE 0884-10 (VDE V 0884-10): 2006-12
- $V_{IORM} = 560$ V peak
- Operating temperature range: -40°C to $+85^{\circ}\text{C}$
- Wide body, 16-lead SOIC package

APPLICATIONS

- Isolated RS-485/RS-422 interfaces
- PROFIBUS networks
- Industrial field networks
- Multipoint data transmission systems

GENERAL DESCRIPTION

The ADM2486 differential bus transceiver is an integrated, galvanically isolated component designed for bidirectional data communication on multipoint bus transmission lines. It is designed for balanced transmission lines and complies with ANSI EIA/TIA-485-A and ISO 8482: 1987(E).

The device employs Analog Devices *iCoupler*® technology to combine a 3-channel isolator, a three-state differential line driver, and a differential input receiver into a single package. The logic side of the device is powered with either a 5 V or a 3 V supply, and the bus side uses an isolated 5 V supply.

FUNCTIONAL BLOCK DIAGRAM

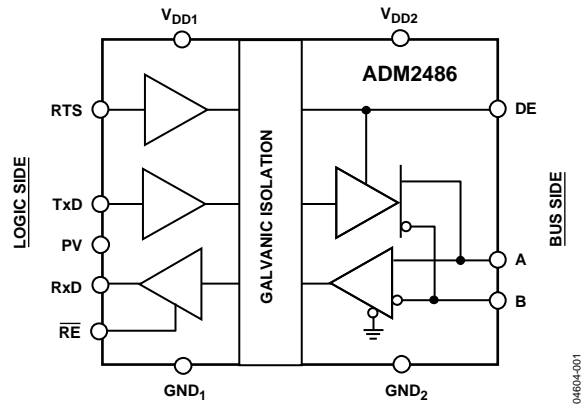

Figure 1.

The ADM2486 driver has an active-high enable feature. The driver differential outputs and the receiver differential inputs are connected internally to form a differential input/output port that imposes minimal loading on the bus when the driver is disabled or when V_{DD1} or $V_{DD2} = 0$ V. Also provided is an active-high receiver disable feature that causes the receive output to enter a high impedance state.

The device has current-limiting and thermal shutdown features to protect against output short circuits and situations where bus contention may cause excessive power dissipation. The part is fully specified over the industrial temperature range and is available in a 16-lead, wide body SOIC package.

TABLE OF CONTENTS

Features	1	Switching Characteristics	11
Applications.....	1	Typical Performance Characteristics	12
General Description	1	Circuit Description.....	14
Functional Block Diagram	1	Electrical Isolation.....	14
Revision History	2	Truth Tables.....	14
Specifications.....	3	Power-Up/Power-Down Thresholds	14
Timing Specifications.....	5	Thermal Shutdown	15
ADM2486 Characteristics	6	Receiver Fail-Safe Inputs	15
Package Characteristics	6	Magnetic Field Immunity.....	15
Regulatory Information.....	6	Applications Information	16
Insulation and Safety-Related Specifications.....	6	PC Board Layout	16
VDE 0884-10 Insulation Characteristics.....	7	Power_Valid Input	16
Absolute Maximum Ratings.....	8	Isolated Power Supply Circuit	17
ESD Caution.....	8	Outline Dimensions	18
Pin Configuration and Function Descriptions.....	9	Ordering Guide	18
Test Circuits.....	10		

REVISION HISTORY

11/13—Rev. D to Rev. E

Changes to Features Section.....	1
Changes to Table 4.....	6
Changes to VDE 0884-10 Insulation Characteristics Section and Table 6.....	7
Updated Outline Dimensions	18
Changes to Ordering Guide	18

2/06—Rev. C to Rev. D

Updated Format.....	Universal
Changes to Table 1	3
Changes to Table 8.....	9
Changes to Figure 22 and Figure 23.....	13
Changes to Table 9 and Table 10.....	14
Added PC Board Layout Section	16
Changes to Isolated Power Supply Circuit Section and Figure 32	17

3/05—Rev. B to Rev. C

Change to Package Characteristics	7
Changes to Figure 12, Figure 14, and Figure 15.....	11
Change to Power_Valid Input Section.....	16

1/05—Rev. A to Rev. B

Added PROFIBUS logo	1
---------------------------	---

11/04—Rev. 0 to Rev. A

Changes to Figure 1	1
Changes to Figure 6.....	10
Added Figure 22 through Figure 25.....	13
Updated Outline Dimensions	18
Changes to Ordering Guide	18

SPECIFICATIONS

$2.7\text{ V} \leq V_{DD1} \leq 5.5\text{ V}$, $4.75\text{ V} \leq V_{DD2} \leq 5.25\text{ V}$, $T_A = T_{MIN}$ to T_{MAX} , unless otherwise noted.

Table 1.

Parameter	Min	Typ	Max	Unit	Test Conditions/Comments
DRIVER					
Differential Outputs					
Differential Output Voltage, V_{OD}			5	V	$R = \infty$, see Figure 3
	2.1		5	V	$R = 50\ \Omega$ (RS-422), see Figure 3
	2.1		5	V	$R = 27\ \Omega$ (RS-485), see Figure 3
	2.1		5	V	$V_{TST} = -7\text{ V}$ to $+12\text{ V}$, $V_{DD1} \geq 4.7$, see Figure 4
$\Delta V_{OD} $ for Complementary Output States			0.2	V	$R = 27\ \Omega$ or $50\ \Omega$, see Figure 3
Common-Mode Output Voltage, V_{OC}			3	V	$R = 27\ \Omega$ or $50\ \Omega$, see Figure 3
$\Delta V_{OC} $ for Complementary Output States			0.2	V	$R = 27\ \Omega$ or $50\ \Omega$, see Figure 3
Output Short-Circuit Current, $V_{OUT} = \text{High}$	60		200	mA	$-7\text{ V} \leq V_{OUT} \leq +12\text{ V}$
Output Short-Circuit Current, $V_{OUT} = \text{Low}$	60		200	mA	$-7\text{ V} \leq V_{OUT} \leq +12\text{ V}$
Driver Enable Output, DE Pin					
Output High Voltage	$V_{DD2} - 0.1$			V	$I_{ODE} = 20\ \mu\text{A}$
	$V_{DD2} - 0.3$	$V_{DD2} - 0.1$		V	$I_{ODE} = 1.6\text{ mA}$
	$V_{DD2} - 0.4$	$V_{DD2} - 0.2$		V	$I_{ODE} = 4\text{ mA}$
Output Low Voltage			0.1	V	$I_{ODE} = -20\ \mu\text{A}$
		0.1	0.3	V	$I_{ODE} = -1.6\text{ mA}$
		0.2	0.4	V	$I_{ODE} = -4\text{ mA}$
Logic Inputs					
Input High Voltage	$0.7 V_{DD1}$			V	TxD, RTS, $\overline{\text{RE}}$, PV
Input Low Voltage			$0.25 V_{DD1}$	V	TxD, RTS, $\overline{\text{RE}}$, PV
CMOS Logic Input Current (TxD, RTS, $\overline{\text{RE}}$, PV)	-10	+0.01	+10	μA	TxD, RTS, $\overline{\text{RE}}$, PV = V_{DD1} or 0 V
RECEIVER					
Differential Inputs					
Differential Input Threshold Voltage, V_{TH}	-200		+200	mV	$-7\text{ V} \leq V_{CM} \leq +12\text{ V}$
Input Hysteresis		70		mV	$-7\text{ V} \leq V_{CM} \leq +12\text{ V}$
Input Resistance (A, B)	20	30		k Ω	$-7\text{ V} \leq V_{CM} \leq +12\text{ V}$
Input Current (A, B)			0.6	mA	$V_{IN} = +12\text{ V}$
			-0.35	mA	$V_{IN} = -7\text{ V}$
RxD Logic Output					
Output High Voltage	$V_{DD1} - 0.1$			V	$I_{OUT} = 20\ \mu\text{A}$, $V_A - V_B = 0.2\text{ V}$
	$V_{DD1} - 0.4$	$V_{DD1} - 0.2$		V	$I_{OUT} = 4\text{ mA}$, $V_A - V_B = 0.2\text{ V}$
Output Low Voltage			0.1	V	$I_{OUT} = -20\ \mu\text{A}$, $V_A - V_B = -0.2\text{ V}$
		0.2	0.4	V	$I_{OUT} = -4\text{ mA}$, $V_A - V_B = -0.2\text{ V}$
Output Short-Circuit Current	7		85	mA	$V_{OUT} = \text{GND}$ or V_{CC}
Three-State Output Leakage Current			± 1	μA	$0.4\text{ V} \leq V_{OUT} \leq 2.4\text{ V}$
POWER SUPPLY CURRENT					
Logic Side			1.3	mA	RTS = 0 V, $V_{DD1} = 5.5\text{ V}$
		1.0		mA	2 Mbps, $V_{DD1} = 5.5\text{ V}$, see Figure 5
		4.0		mA	20 Mbps, $V_{DD1} = 5.5\text{ V}$, see Figure 5
			0.8	mA	RTS = 0 V, $V_{DD1} = 3\text{ V}$
			1.1	mA	2 Mbps, $V_{DD1} = 3\text{ V}$, see Figure 5
		2.1		mA	20 Mbps, $V_{DD1} = 3\text{ V}$, see Figure 5
Bus Side			3.0	mA	RTS = 0 V
		43.0		mA	2 Mbps, RTS = V_{DD1} , see Figure 5
		58.0		mA	20 Mbps, RTS = V_{DD1} , see Figure 5

Parameter	Min	Typ	Max	Unit	Test Conditions/Comments
COMMON-MODE TRANSIENT IMMUNITY ¹	25			kV/ μ s	$V_{CM} = 1$ kV, transient magnitude = 800 V
HIGH FREQUENCY, COMMON-MODE NOISE IMMUNITY		100		mV	$V_{HF} = +5$ V, -2 V $< V_{TEST2} < +7$ V, 1 MHz $< f_{TEST} < 50$ MHz, see Figure 6

¹ Common-mode transient immunity is the maximum common-mode voltage slew rate that can be sustained while maintaining specification-compliant operation. V_{CM} is the common-mode potential difference between the logic and bus sides. The transient magnitude is the range over which the common-mode is slewed. The common-mode voltage slew rates apply to both rising and falling common-mode voltage edges.

TIMING SPECIFICATIONS

$2.7\text{ V} \leq V_{DD1} \leq 5.5\text{ V}$, $4.75\text{ V} \leq V_{DD2} \leq 5.25\text{ V}$, $T_A = T_{MIN}$ to T_{MAX} , unless otherwise noted.

Table 2.

Parameter	Min	Typ	Max	Unit	Test Conditions/Comments
DRIVER					
Maximum Data Rate	20			Mbps	
Propagation Delay, t_{PLH} , t_{PHL}	25	45	55	ns	$R_{LDIFF} = 54\ \Omega$, $C_{L1} = C_{L2} = 100\text{ pF}$, see Figure 7
RTS-to-DE Propagation Delay	20	35	55	ns	See Figure 8
Pulse Width Distortion, t_{PWD}			5	ns	$R_{LDIFF} = 54\ \Omega$, $C_{L1} = C_{L2} = 100\text{ pF}$, see Figure 7 and Figure 12
Switching Skew, t_{SKEW}		2	5	ns	$R_{LDIFF} = 54\ \Omega$, $C_{L1} = C_{L2} = 100\text{ pF}$, see Figure 7 and Figure 12
Rise/Fall Time, t_R , t_F		5	15	ns	$R_{LDIFF} = 54\ \Omega$, $C_{L1} = C_{L2} = 100\text{ pF}$, see Figure 7 and Figure 12
Enable Time		43	53	ns	See Figure 9 and Figure 14
Disable Time		43	55	ns	See Figure 9 and Figure 14
Enable Skew, $ t_{AZH} - t_{BZL} $, $ t_{AZL} - t_{BZH} $		1	3	ns	See Figure 9 and Figure 14
Disable Skew, $ t_{AHZ} - t_{BLZ} $, $ t_{ALZ} - t_{BHZ} $		2	5	ns	See Figure 9 and Figure 14
RECEIVER					
Propagation Delay, t_{PLH} , t_{PHL}	25	45	55	ns	$C_L = 15\text{ pF}$, see Figure 10 and Figure 13
Differential Skew, t_{SKEW}			5	ns	$C_L = 15\text{ pF}$, see Figure 10 and Figure 13
Enable Time		3	13	ns	$R_L = 1\text{ k}\Omega$, $C_L = 15\text{ pF}$, see Figure 11 and Figure 15
Disable Time		3	13	ns	$R_L = 1\text{ k}\Omega$, $C_L = 15\text{ pF}$, see Figure 11 and Figure 15
POWER_VALID INPUT					
Enable Time		1	2	μs	
Disable Time		3	5	μs	

ADM2486 CHARACTERISTICS

PACKAGE CHARACTERISTICS

Table 3.

Parameter	Symbol	Min	Typ	Max	Unit	Test Conditions
Resistance (Input-to-Output) ¹	R _{I-O}		10 ¹²		Ω	
Capacitance (Input-to-Output) ¹	C _{I-O}		3		pF	f = 1 MHz
Input Capacitance ²	C _I		4		pF	
Input IC Junction-to-Case Thermal Resistance	θ _{JCI}		33		°C/W	Thermocouple located at center of package underside
Output IC Junction-to-Case Thermal Resistance	θ _{JCO}		28		°C/W	

¹ Device considered a 2-terminal device: Pin 1 through Pin 8 shorted together, and Pin 9 through Pin 16 shorted together.

² Input capacitance is from any input data pin to ground.

REGULATORY INFORMATION

The [ADM2486](#) has been approved by the following organizations:

Table 4.

Organization	Approval Type	Notes
UL	Recognized under 1577 component recognition program. File E214100.	In accordance with UL1577, each ADM2486 is proof tested by applying an insulation test voltage ≥3000 V _{rms} for 1 sec (current leakage detection limit = 5 μA).
CSA	Approved under CSA Component Acceptance Notice #5A. File 205078. IEC 609501 800 V _{rms} (1131 V _{PEAK}) Basic, 400 V _{rms} (565 V _{PEAK}) reinforced.	
VDE	Certified according to DIN V VDE V 0884-10 (VDE V 0884-10): 2006-12. File 2471900-4880-0001.	

INSULATION AND SAFETY-RELATED SPECIFICATIONS

Table 5.

Parameter	Symbol	Value	Unit	Conditions
Rated Dielectric Insulation Voltage		2500	V rms	1-minute duration.
Minimum External Air Gap (Clearance)	L(I01)	7.45 minimum	mm	Measured from input terminals to output terminals, shortest distance through air.
Minimum External Tracking (Creepage)	L(I02)	8.1 minimum	mm	Measured from input terminals to output terminals, shortest distance along body.
Minimum Internal Gap (Internal Clearance)		0.017 minimum	mm	Insulation distance through insulation.
Tracking Resistance (Comparative Tracking Index)	CTI	>175	V	DIN IEC 112/VDE 0303 Part 1.
Isolation Group		IIIa		Material Group (DIN VDE 0110, 1/89, Table 1).

VDE 0884-10 INSULATION CHARACTERISTICS

This isolator is suitable for reinforced electrical isolation only within the safety limit data. Maintenance of the safety data must be ensured by means of protective circuits.

An asterisk (*) on the physical package denotes VDE V 0884-10 approval for 560 V peak working voltage.

Table 6.

Description	Symbol	Characteristic	Unit
Installation Classification per DIN VDE 0110 for Rated Mains Voltage ≤ 150 V rms ≤ 300 V rms ≤ 400 V rms		I-IV I-II I-II	
Climatic Classification		40/100/21	
Pollution Degree (DIN VDE 0110, Table 1)		2	
Maximum Working Insulation Voltage	V_{IORM}	560	V_{PEAK}
Input-to-Output Test Voltage, Method b1 $V_{IORM} \times 1.875 = V_{PR}$, 100% Production Tested, $t_m = 1$ sec, Partial Discharge < 5 pC	V_{PR}	1050	V_{PEAK}
Input-to-Output Test Voltage, Method a After Environmental Tests, Subgroup 1 $V_{IORM} \times 1.6 = V_{PR}$, $t_m = 60$ sec, Partial Discharge < 5 pC After Input and/or Safety Test, Subgroup 2/3 $V_{IORM} \times 1.2 = V_{PR}$, $t_m = 60$ sec, Partial Discharge < 5 pC	V_{PR}	896 672	V_{PEAK} V_{PEAK}
Highest Allowable Overvoltage (Transient Overvoltage, $t_{tr} = 10$ sec) Safety-Limiting Values (Maximum Value Allowed in the Event of a Failure, see Figure 21)	V_{TR}	4000	V_{PEAK}
Case Temperature	T_S	150	$^{\circ}\text{C}$
Input Current	$I_{S, INPUT}$	265	mA
Output Current	$I_{S, OUTPUT}$	335	mA
Insulation Resistance at T_S , $V_{IO} = 500$ V	R_S	$>10^9$	Ω

ABSOLUTE MAXIMUM RATINGS

$T_A = 25^\circ\text{C}$, unless otherwise noted. All voltages are relative to their respective ground.

Table 7.

Parameter	Rating
V_{DD1}	-0.5 V to +7 V
V_{DD2}	-0.5 V to +6 V
Digital Input Voltage (RTS, $\overline{\text{RE}}$, TxD)	-0.5 V to $V_{DD1} + 0.5 \text{ V}$
Digital Output Voltage	
RxD	-0.5 V to $V_{DD1} + 0.5 \text{ V}$
DE	-0.5 V to $V_{DD2} + 0.5 \text{ V}$
Driver Output/Receiver Input Voltage	-9 V to +14 V
Operating Temperature Range	-40°C to +85°C
Storage Temperature Range	-55°C to +150°C
Average Output Current per Pin	-35 mA to +35 mA
θ_{JA} Thermal Impedance	73°C/W
Lead Temperature	
Soldering (10 sec)	260°C
Vapor Phase (60 sec)	215°C
Infrared (15 sec)	220°C

Stresses above those listed under Absolute Maximum Ratings may cause permanent damage to the device. This is a stress rating only; functional operation of the device at these or any other conditions above those indicated in the operational section of this specification is not implied. Exposure to absolute maximum rating conditions for extended periods may affect device reliability.

ESD CAUTION



ESD (electrostatic discharge) sensitive device. Charged devices and circuit boards can discharge without detection. Although this product features patented or proprietary protection circuitry, damage may occur on devices subjected to high energy ESD. Therefore, proper ESD precautions should be taken to avoid performance degradation or loss of functionality.

PIN CONFIGURATION AND FUNCTION DESCRIPTIONS

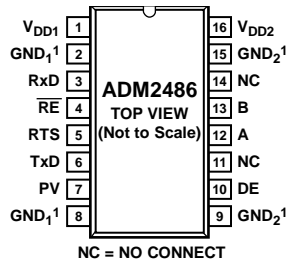

¹ PIN 2 AND PIN 8 ARE INTERNALLY CONNECTED. EITHER OR BOTH MAY BE USED FOR GND₁.
PIN 9 AND PIN 15 ARE INTERNALLY CONNECTED. EITHER OR BOTH MAY BE USED FOR GND₂.

04604-003

Figure 2. Pin Configuration

Table 8. Pin Function Descriptions

Pin No.	Mnemonic	Description
1	V _{DD1}	Power Supply (Logic Side), 3 V or 5 V Supply. Decoupling capacitor to GND ₁ required, capacitor value should be between 0.01 μ F and 0.1 μ F.
2, 8	GND ₁	Ground (Logic Side).
3	RxD	Receiver Output Data. This output is high when (A – B) > 200 mV and low when (A – B) < –200 mV. The output is three-stated when the receiver is disabled, that is, when $\overline{\text{RE}}$ is driven high.
4	$\overline{\text{RE}}$	Receiver Enable Input. This is an active-low input. Driving this input low enables the receiver, and driving it high disables the receiver.
5	RTS	Request to Send Input. Driving this input high enables the driver, and driving it low disables the driver.
6	TxD	Transmit Data Input. Data to be transmitted by the driver is applied to this input.
7	PV	Power_Valid. Used during power-up and power-down, needs to be tied high when the ADM2486 is operational, see the Applications Information section.
9, 15	GND ₂	Ground (Bus Side).
10	DE	Driver Enable Status Output. This output signals the driver enable or disable status to other devices on the bus. DE is high when the driver is enabled and low when the driver is disabled.
11, 14	NC	No Connect.
12	A	Noninverting Driver Output/Receiver Input. When the driver is disabled, or when V _{DD1} or V _{DD2} is powered down, Pin A is put into a high impedance state to avoid overloading the bus.
13	B	Inverting Driver Output/Receiver Input. When the driver is disabled, or when V _{DD1} or V _{DD2} is powered down, Pin B is put into a high impedance state to avoid overloading the bus.
16	V _{DD2}	Power Supply (Bus Side), 5 V Isolated Supply. Decoupling capacitor to GND ₂ required, capacitor value should be between 0.01 μ F and 0.1 μ F.

TEST CIRCUITS

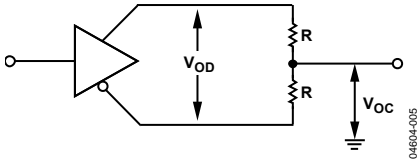

Figure 3. Driver Voltage Measurement

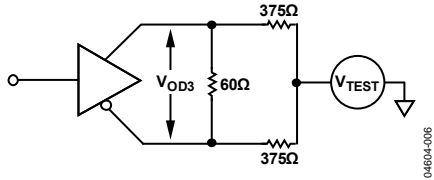

Figure 4. Driver Voltage Measurement

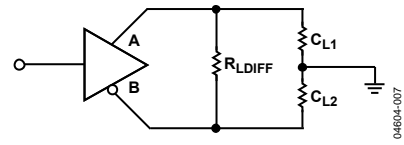

Figure 7. Driver Propagation Delay

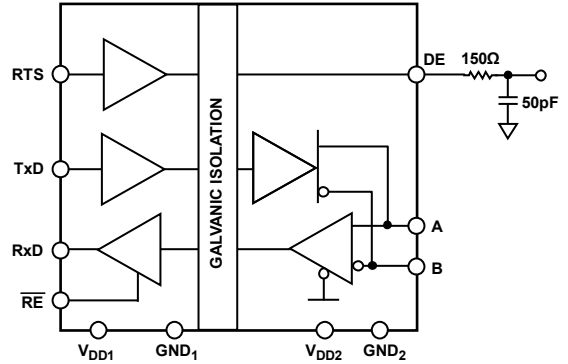

Figure 8. RTS-to-DE Propagation Delay

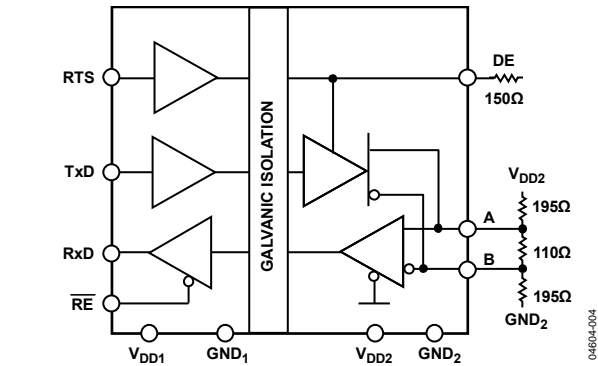

Figure 5. Supply-Current Measurement Test Circuit

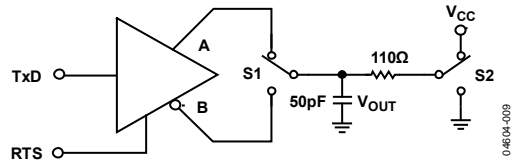

Figure 9. Driver Enable/Disable

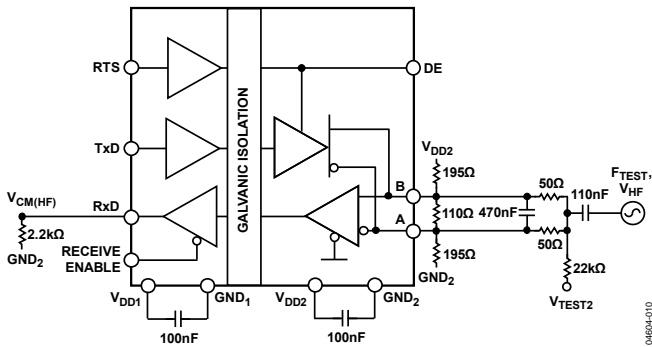

Figure 6. High Frequency Common-Mode Noise Test Circuit

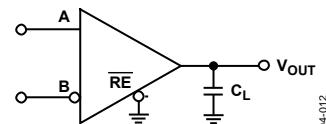

Figure 10. Receiver Propagation Delay

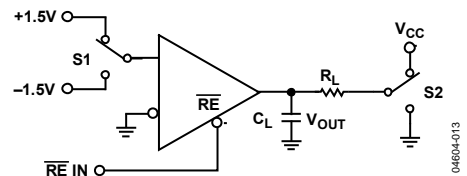

Figure 11. Receiver Enable/Disable

SWITCHING CHARACTERISTICS

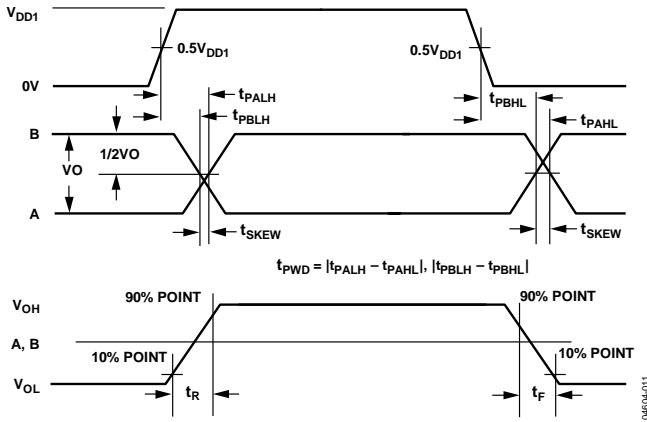

Figure 12. Driver Propagation Delay, Rise/Fall Timing

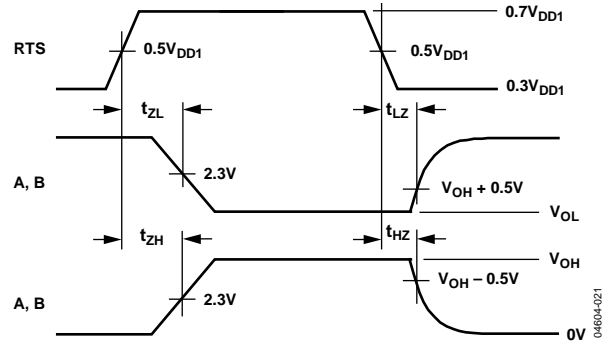

Figure 14. Driver Enable/Disable Timing

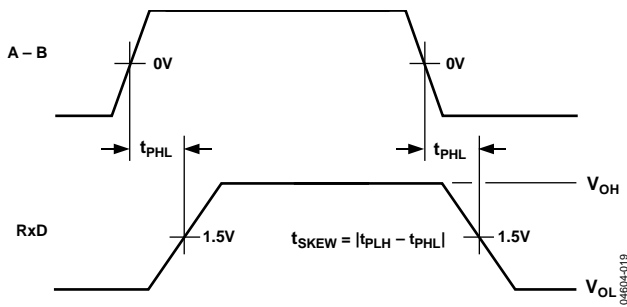

Figure 13. Receiver Propagation Delay

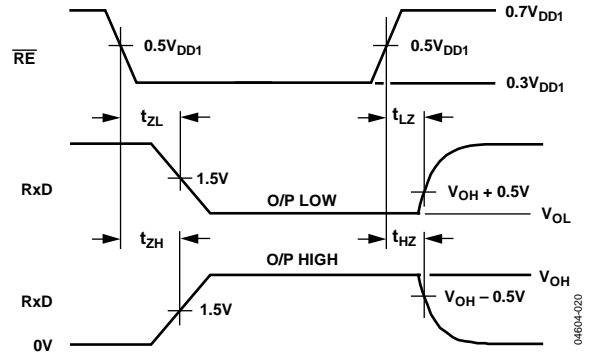

Figure 15. Receiver Enable/Disable Timing

TYPICAL PERFORMANCE CHARACTERISTICS

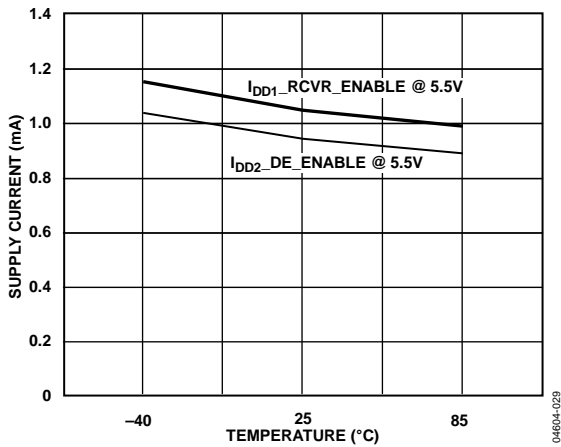

Figure 16. Unloaded Supply Current vs. Temperature

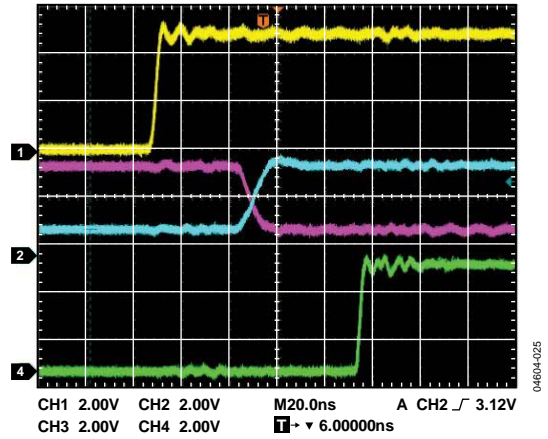

Figure 19. Driver/Receiver Propagation Delay, Low to High ($R_{LDiff} = 54 \Omega$, $C_{L1} = C_{L2} = 100 \text{ pF}$)

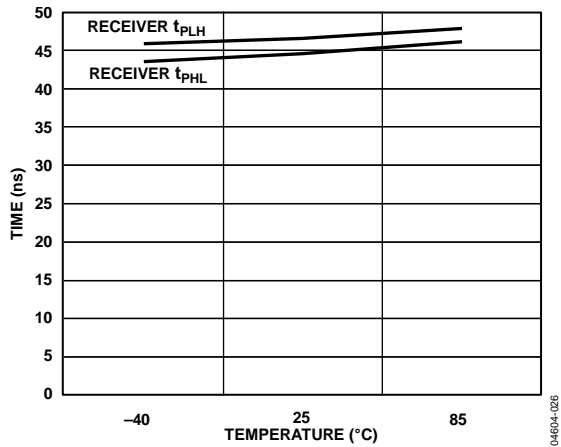

Figure 17. Driver Propagation Delay vs. Temperature

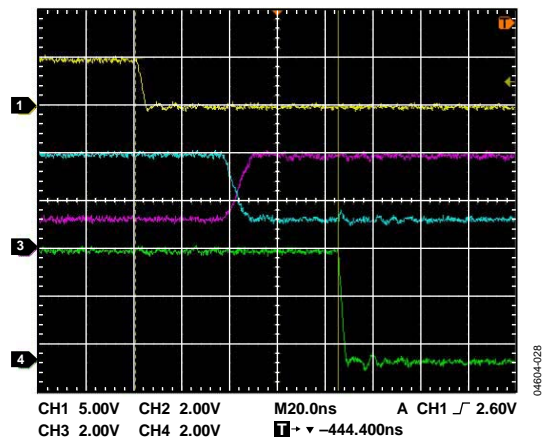

Figure 20. Driver/Receiver Propagation Delay, High to Low ($R_{LDiff} = 54 \Omega$, $C_{L1} = C_{L2} = 100 \text{ pF}$)

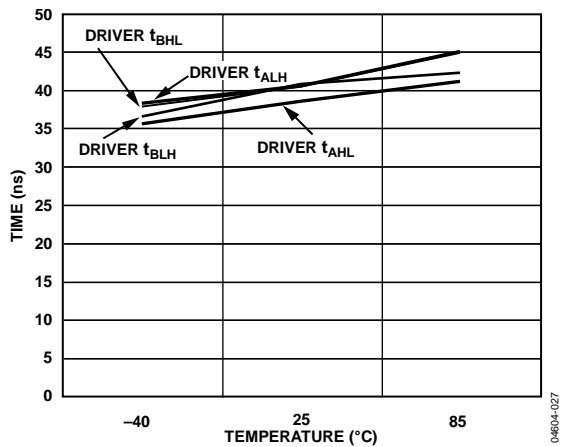

Figure 18. Receiver Propagation Delay vs. Temperature

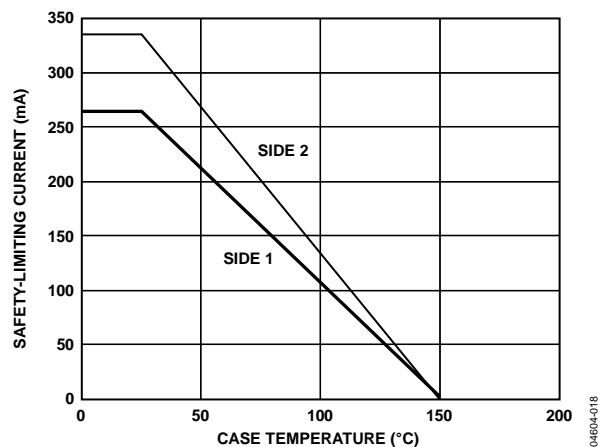

Figure 21. Thermal Derating Curve, Dependence of Safety-Limiting Values with Case Temperature per VDE 0884

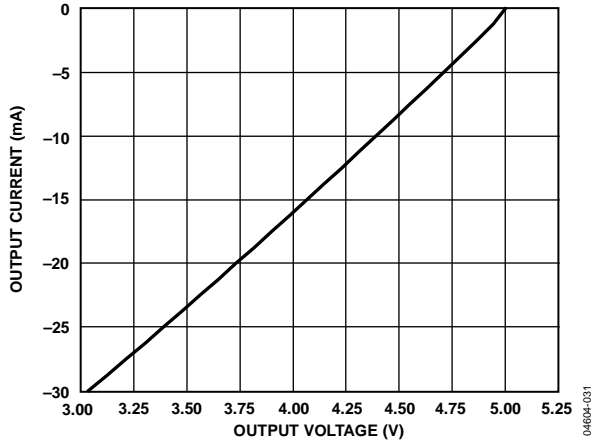

Figure 22. Output Current vs. Receiver Output High Voltage

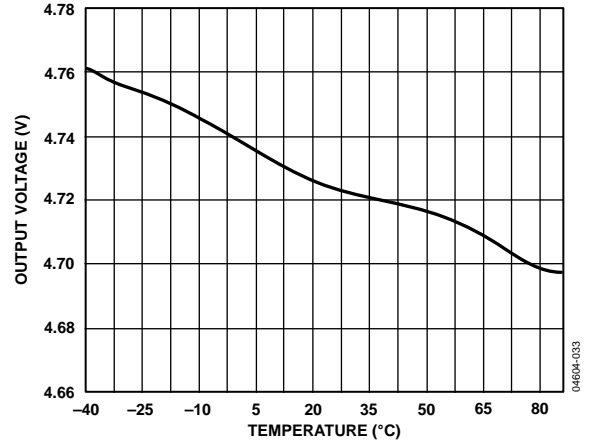

Figure 24. Receiver Output High Voltage vs. Temperature
 $I_{RXD} = -4 \text{ mA}$

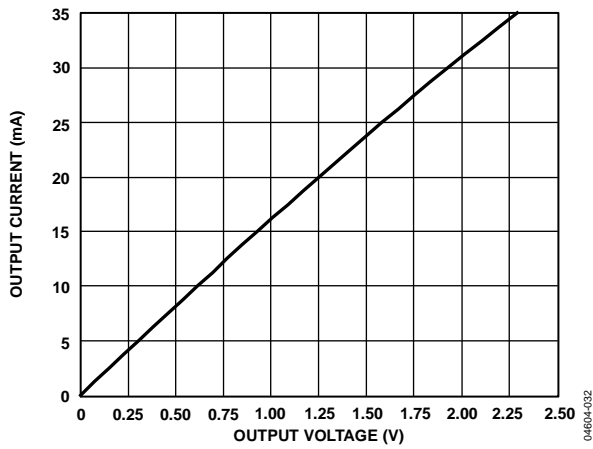

Figure 23. Output Current vs. Receiver Output Low Voltage

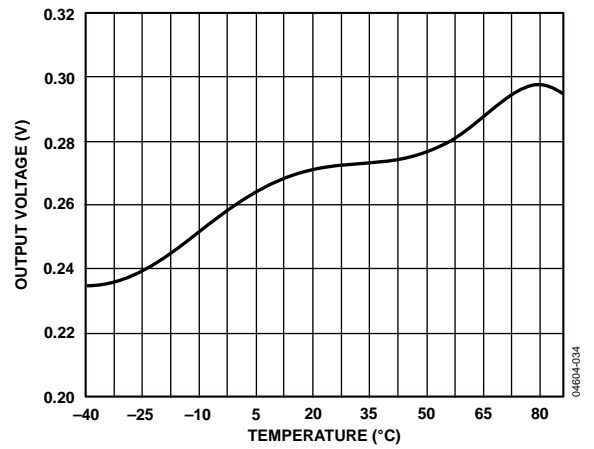

Figure 25. Receiver Output Low Voltage vs. Temperature
 $I_{RXD} = -4 \text{ mA}$

CIRCUIT DESCRIPTION

ELECTRICAL ISOLATION

In the [ADM2486](#), electrical isolation is implemented on the logic side of the interface. Therefore, the part has two main sections: a digital isolation section and a transceiver section (see Figure 26). Driver input and request-to-send signals, applied to the TxD and RTS pins, respectively, and referenced to logic ground (GND_1), are coupled across an isolation barrier to appear at the transceiver section referenced to isolated ground (GND_2). Similarly, the receiver output, referenced to isolated ground in the transceiver section, is coupled across the isolation barrier to appear at the RxD pin referenced to logic ground.

iCoupler Technology

The digital signals are transmitted across the isolation barrier using iCoupler technology. This technique uses chip-scale transformer windings to couple the digital signals magnetically from one side of the barrier to the other. Digital inputs are encoded into waveforms that are capable of exciting the primary transformer winding. At the secondary winding, the induced waveforms are then decoded into the binary value that was originally transmitted.

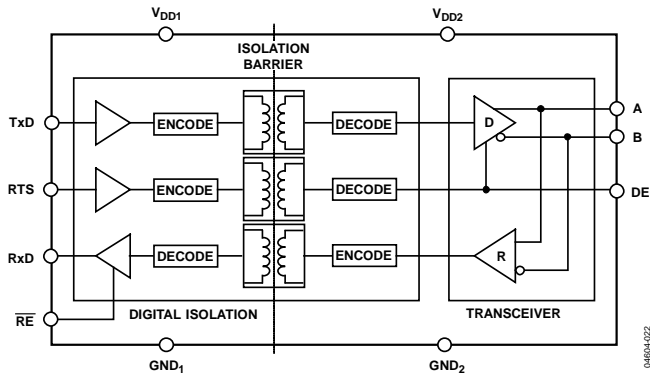

Figure 26. ADM2486 Digital Isolation and Transceiver Sections

TRUTH TABLES

The truth tables in this section use these abbreviations:

Letter	Description
H	High level
I	Indeterminate
L	Low level
X	Irrelevant
Z	High impedance (off)
NC	Disconnected

Table 9. Transmitting

Supply Status		Inputs		Outputs ¹		
V _{DD1}	V _{DD2}	RTS	TxD	A	B	DE
On	On	H	H	H	L	H
On	On	H	L	L	H	H
On	On	L	X	Z	Z	L
On	Off	X	X	Z	Z	L
Off	On	X	X	Z	Z	L
Off	Off	X	X	Z	Z	L

¹ The PV pin is tied high.

Table 10. Receiving

Supply Status		Inputs	Output ¹	
V _{DD1}	V _{DD2}	A – B (V)	RE	RxD
On	On	>0.2	L or NC	H
On	On	<-0.2	L or NC	L
On	On	-0.2 < A – B < 0.2	L or NC	I
On	On	Inputs open	L or NC	H
On	On	X	H	Z
On	Off	X	L or NC	H
Off	On	X	L or NC	H
Off	Off	X	L or NC	L

¹ The PV pin is tied high.

POWER-UP/POWER-DOWN THRESHOLDS

The power-up/power-down characteristics of the [ADM2486](#) are in accordance with the supply thresholds shown in Table 11. Upon power-up, the [ADM2486](#) output signals (A, B, RxD, and DE) reach their correct state once both supplies have exceeded their thresholds. Upon power-down, the [ADM2486](#) output signals retain their correct state until at least one of the supplies drops below its power-down threshold. When the V_{DD1} power-down threshold is crossed, the [ADM2486](#) output signals reach their unpowered states within 4 μs.

Table 11. Power-Up/Power-Down Thresholds

Supply	Transition	Threshold (V)
V _{DD1}	Power-up	2.0
V _{DD1}	Power-down	1.0
V _{DD2}	Power-up	3.3
V _{DD2}	Power-down	2.4

THERMAL SHUTDOWN

The ADM2486 contains thermal shutdown circuitry that protects the part from excessive power dissipation during fault conditions. Shorting the driver outputs to a low impedance source can result in high driver currents. The thermal sensing circuitry detects the increase in die temperature under this condition and disables the driver outputs. This circuitry is designed to disable the driver outputs when a die temperature of 150°C is reached. As the device cools, the drivers are re-enabled at a temperature of 140°C.

RECEIVER FAIL-SAFE INPUTS

The receiver input includes a fail-safe feature that guarantees a logic high RxD output when the A and B inputs are floating or open-circuited.

MAGNETIC FIELD IMMUNITY

Because iCouplers use coreless technology, no magnetic components are present, and the problem of magnetic saturation of the core material does not exist. Therefore, iCouplers have essentially infinite dc field immunity. The following analysis defines the conditions under which this can occur. The ADM2486's 3 V operating condition is examined because it represents the most susceptible mode of operation.

The limitation on the iCoupler's ac magnetic field immunity is set by the condition in which the induced error voltage in the receiving coil (the bottom coil in this case) is made sufficiently large, either to falsely set or reset the decoder. The voltage induced across the bottom coil is given by

$$V = \left(\frac{-d\beta}{dt} \right) \sum \pi r_n^2 ; n = 1, 2, \dots, N$$

where if the pulses at the transformer output are greater than 1.0 V in amplitude:

β = magnetic flux density (gauss).

N = number of turns in receiving coil.

r_n = radius of nth turn in receiving coil (cm).

The decoder has a sensing threshold of about 0.5 V; therefore, there is a 0.5 V margin in which induced voltages can be tolerated.

Given the geometry of the receiving coil and an imposed requirement that the induced voltage is, at most, 50% of the 0.5 V margin at the decoder, a maximum allowable magnetic field is calculated as shown in Figure 27.

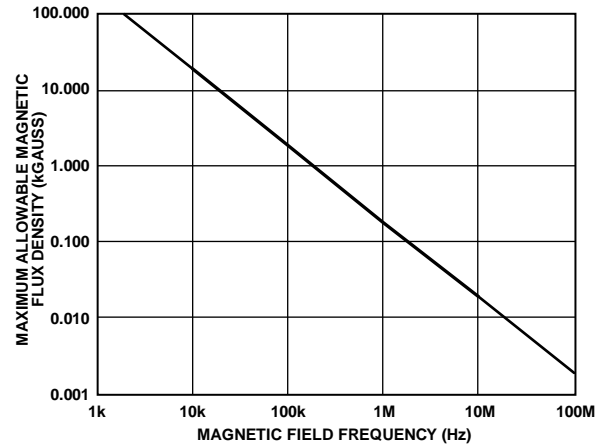

Figure 27. Maximum Allowable External Magnetic Flux Density

For example, at a magnetic field frequency of 1 MHz, the maximum allowable magnetic field of 0.2 kGauss induces a voltage of 0.25 V at the receiving coil. This is about 50% of the sensing threshold and does not cause a faulty output transition. Similarly, if such an event occurs during a transmitted pulse and is the worst-case polarity, it reduces the received pulse from >1.0 V to 0.75 V. This is well above the 0.5 V sensing threshold of the decoder.

Figure 28 shows the magnetic flux density values in terms of more familiar quantities such as maximum allowable current flow at given distances away from the ADM2486 transformers.

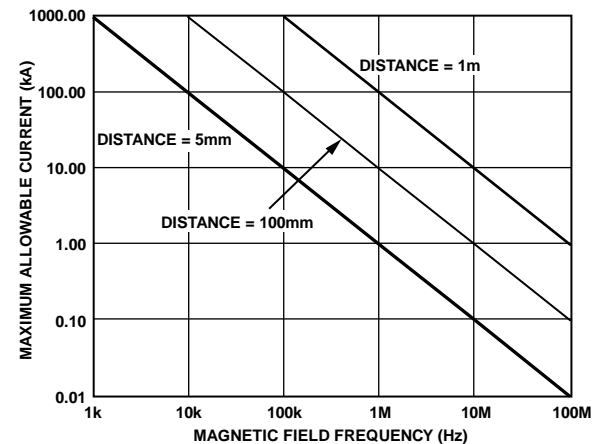

Figure 28. Maximum Allowable Current for Various Current-to-ADM2486 Spacings

At combinations of strong magnetic field and high frequency, any loops formed by printed circuit board traces could induce sufficiently large error voltages to trigger the thresholds of succeeding circuitry. Care should be taken in the layout of such traces to avoid this possibility.

APPLICATIONS INFORMATION

PC BOARD LAYOUT

The ADM2486 isolated RS-485 transceiver requires no external interface circuitry for the logic interfaces. Power supply bypassing is strongly recommended at the input and output supply pins (see Figure 29). Bypass capacitors are most conveniently connected between Pin 1 and Pin 2 for V_{DD1} and between Pin 15 and Pin 16 for V_{DD2} . The capacitor value should be between 0.01 μF and 0.1 μF . The total lead length between both ends of the capacitor and the input power supply pin should not exceed 20 mm. Bypassing between Pin 1 and Pin 8 and between Pin 9 and Pin 16 should also be considered unless the ground pair on each package side is connected close to the package.

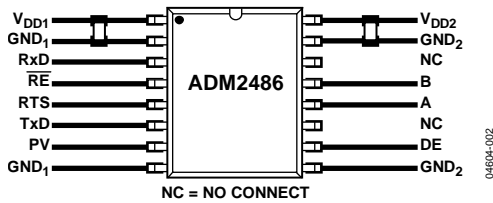

Figure 29. Recommended Printed Circuit Board Layout

In applications involving high common-mode transients, care should be taken to ensure that board coupling across the isolation barrier is minimized. Furthermore, the board layout should be designed such that any coupling that does occur equally affects all pins on a given component side. Failure to ensure this could cause voltage differentials between pins exceeding the device's Absolute Maximum Ratings, thereby leading to latch-up or permanent damage.

POWER_VALID INPUT

To avoid chatter on the A and B outputs caused by slow power-up and power-down transients on V_{DD1} ($>100 \mu\text{s/V}$), the device features a power_valid (PV) digital input. This pin should be driven low until V_{DD1} exceeds 2.0 V. When V_{DD1} is greater than 2.0 V, this pin should be driven high. Conversely, upon power-down, PV should be driven low before V_{DD1} reaches 2.0 V (see Figure 30).

If the PV pin is driven with an open-drain output, the recommended value for the pull-up resistor is a 10 k Ω resistor, bypassed with a 100 pF capacitor to GND_1 (see Figure 31).

The power_valid input can be driven, for example, by the output of a system reset circuit, such as the ADM809Z, which has a threshold voltage of 2.32 V.

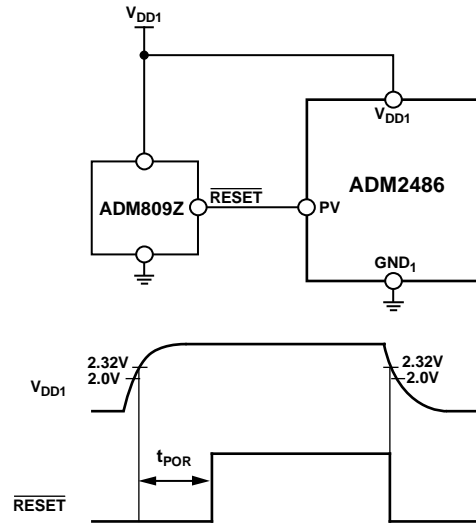

Figure 30. Driving PV with ADM809Z

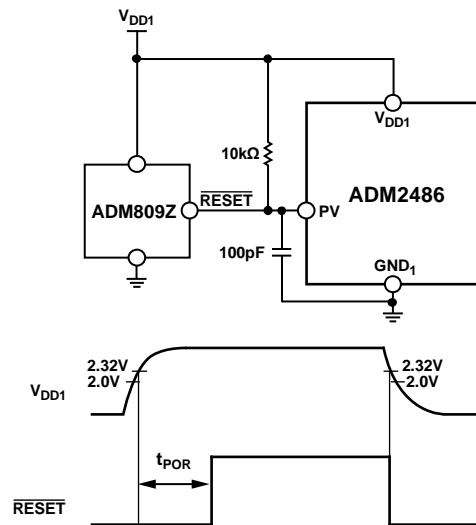

Figure 31. Driving PV with an Open-Drain Output

ISOLATED POWER SUPPLY CIRCUIT

The [ADM2486](#) requires isolated power capable of 5 V at up to approximately 75 mA (this current is dependent on the data rate and termination resistors used) to be supplied between the V_{DD2} and the GND_2 pins.

A transformer driver circuit with a center-tapped transformer and LDO can be used to generate the isolated 5 V supply, as shown in Figure 32. The center-tapped transformer provides electrical isolation of the 5 V isolated power supply. The primary winding of the transformer is excited with a pair of square waveforms that are 180° out of phase with each other. A pair of Schottky diodes and a smoothing capacitor are used to create a rectified signal from the secondary winding. The [ADP667](#) linear voltage regulator provides a regulated 5 V power supply to the [ADM2486](#)'s bus-side circuitry (V_{DD2}).

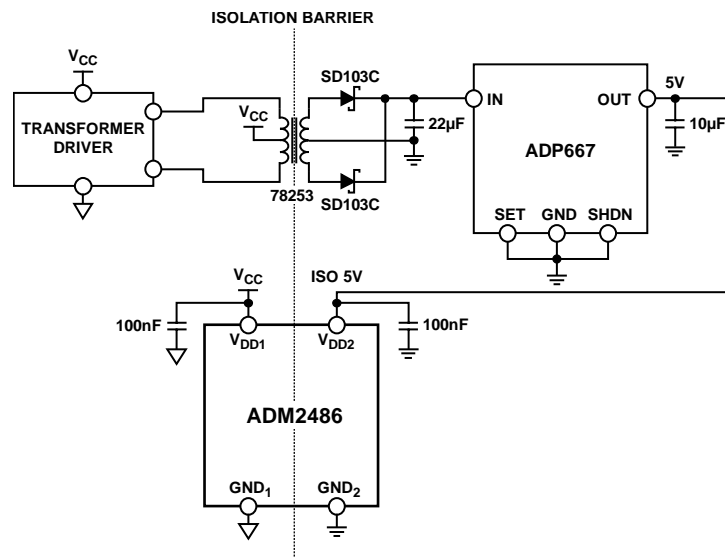
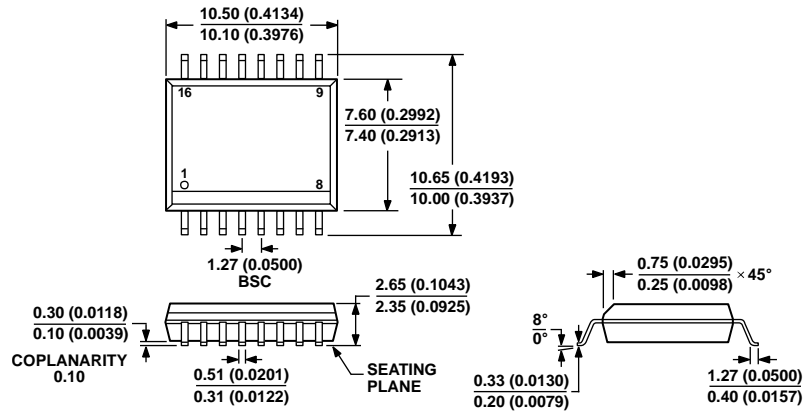

Figure 32. Isolated Power Supply Circuit

04604-035

OUTLINE DIMENSIONS



COMPLIANT TO JEDEC STANDARDS MS-013-AA
 CONTROLLING DIMENSIONS ARE IN MILLIMETERS; INCH DIMENSIONS
 (IN PARENTHESES) ARE ROUNDED-OFF MILLIMETER EQUIVALENTS FOR
 REFERENCE ONLY AND ARE NOT APPROPRIATE FOR USE IN DESIGN.

03-27-2007-B

Figure 33. 16-Lead Standard Small Outline Package [SOIC_W]
 Wide Body (RW-16)
 Dimensions shown in millimeters and (inches)

ORDERING GUIDE

Model ¹	Data Rate (Mbps)	Temperature Range	Package Description	Ordering Quantity	Package Option
ADM2486BRW	20	-40°C to +85°C	16-Lead SOIC_W	47	RW-16
ADM2486BRW-REEL	20	-40°C to +85°C	16-Lead SOIC_W	1,000	RW-16
ADM2486BRWZ	20	-40°C to +85°C	16-Lead SOIC_W	47	RW-16
ADM2486BRWZ-REEL	20	-40°C to +85°C	16-Lead SOIC_W	1,000	RW-16
EVAL-ADM2486EBZ			ADM2486 Evaluation Board		

¹ Z = RoHS Compliant Part.

NOTES

NOTES

Looking for pricing, stock, or lifecycle information?

Click below to explore more details on WIN SOURCE:

 [View ADM2486BRWZ on WIN SOURCE](#)

 [Analog Devices Inc. Information](#)

Optimize Your Supply Chain with WIN SOURCE Solutions

-  Global Sourcing Solution
-  Obsolete Management
-  Cost Control Management
-  Shortage Management
-  Alternative Solution
-  Excess Inventory Management