



**THE DATASHEET OF
NMC0402X7R104K16TRPF**



FEATURES

- CLASS II DIELECTRIC, TEMPERATURE STABLE
- EXCELLENT FREQUENCY CHARACTERISTICS, NON-LINEAR CAPACITANCE CHANGE
- HIGHER CAPACITANCE THAN NPO
- NICKEL BARRIER TERMINATIONS AND EXCELLENT MECHANICAL STRENGTH

**RoHS
Compliant**

Includes all homogeneous materials

*See Part Number System for Details

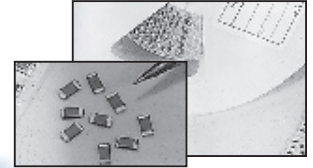

SPECIFICATIONS

Capacitance Range	47pF ~ 0.82μF (see high CV datasheet for higher capacitance values)
Capacitance Tolerance	±5% (J), ±10% (K), ±20% (M)
Operating Temperature Range	-55°C ~ +125°C
Temperature Characteristics	±15%Δ max. over temperature range (with 0 Vdc applied)
Rated Voltages	10Vdc, 16Vdc, 25Vdc, 35Vdc, 50Vdc (see NMC-H Series for higher voltages)
Dissipation Factor	2.5% max. (50Vdc, 100Vdc); 3.5% max. (16Vdc, 25Vdc) 5% max. (10Vdc) @ 1.0Vrms and 1KHz, +25°C
Insulation Resistance	10,000Megohms min. or 500Megohm/μF min. whichever is less @ +25°C
Dielectric Withstanding Voltage	250% of Rated Voltage for 1 ~ 5 seconds, 50mA maximum current
Test Conditions (EIA-198-2E)	1KHz, 1.0V ±0.2Vrms

Note: Reflow soldering allowed for all case sizes. Contact NIC for wave soldering restrictions.

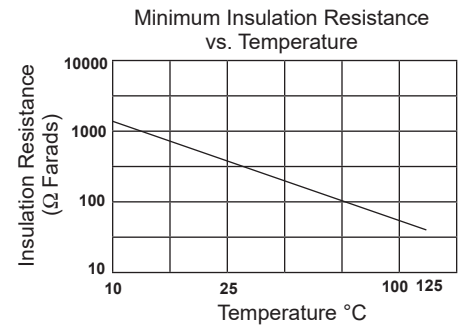
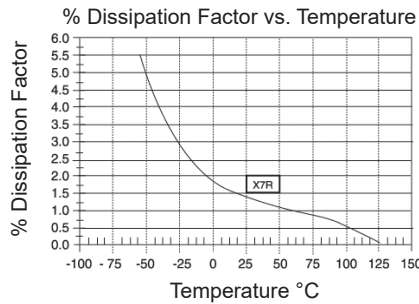
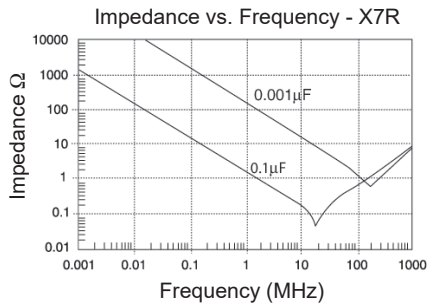
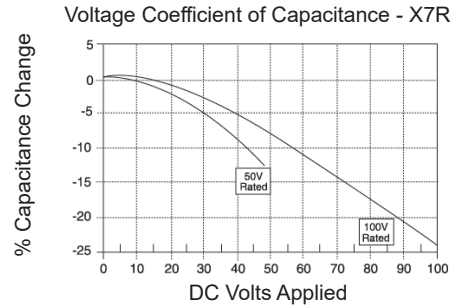
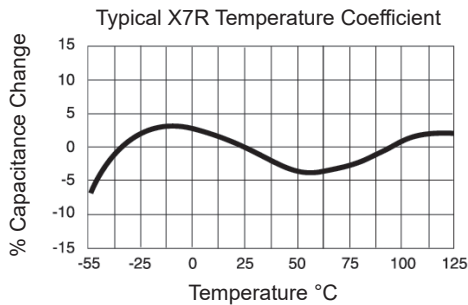

PART NUMBER SYSTEM

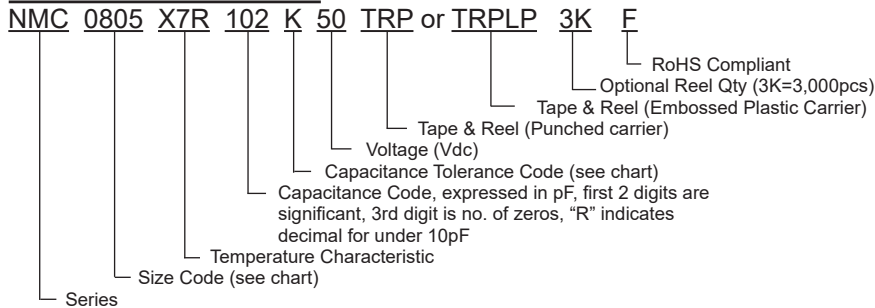

X7R CAPACITOR SIZE CHART (mm)

EIA Case Size	0201				0402				0603				0805							
Length (L)	0.6±0.03				1.0±0.05				1.6±0.15				2.0±0.2							
Width (W)	0.3±0.03				0.5±0.05				0.8±0.15				1.25±0.2							
Thickness max. (T)	0.33				0.6				1.0				1.35							
Termination Width (P)	0.15±0.05				0.2±0.1				0.12 ~ 0.51				0.25 ~ 0.71							
Capacitance	Working Voltage (Vdc)																			
	10	16	25	50	10	16	25	50	10	16	25	50	100	10	16	25	50	100		
47pF ~ 91pF																				
100pF ~ 470pF																				
510pF																				
560pF																				
620pF																				
680pF																				
750pF																				
820pF																				
910pF																				
0.001µF																				
0.0012µF																				
0.0015µF																				
0.0018µF																				
0.0022µF																				
0.0027µF																				
0.0030µF																				
0.0033µF																				
0.0039µF																				
0.0047µF																				
0.0056µF																				
0.0068µF																				
0.0075µF																				
0.0082µF																				
0.01µF																				
0.012µF																				
0.015µF																				
0.018µF																				
0.022µF																				
0.027µF																				
0.033µF																				
0.039µF																				
0.047µF																				
0.056µF																				
0.068µF																				
0.082µF																				
0.1µF																			*	
0.15µF															*	*	*			
0.18µF															*	*	*			
0.22µF															*	*	*			
0.27µF															*	*	*			
0.33µF															*	*	*			
0.39µF															*	*	*	*		
0.47µF															*	*	*	*		
0.56µF															*	*	*			
0.68µF															*	*	*			
0.82µF															*	*	*			

*1.45mm maximum thickness

See NMC High CV series for values above 0.82µF

(CONSULT FACTORY FOR CAPACITANCE VALUES NOT LISTED)

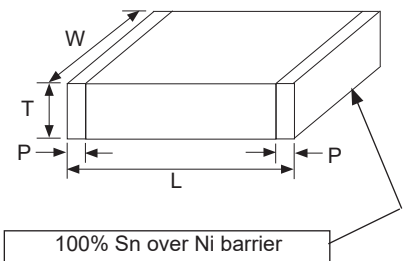

X7R CAPACITOR SIZE CHART (mm)

EIA Case Size	1206					1210					1812					2225			
Length (L)	3.2±0.2					3.2±0.2					4.5±0.3					5.7±0.4			
Width (W)	1.6±0.2					2.5±0.2					3.2±0.25					6.35±0.25			
Thickness max. (T)	1.80					1.80					1.8					1.80			
Termination Width (P)	0.25 ~ 0.71					0.25~0.75					0.25 ~ 0.75					0.25 ~ 1.02			
Capacitance	Working Voltage (Vdc)																		
	10	16	25	50	100	10	16	25	35	50	100	10	16	25	50	100	25	50	100
150pF ~ 910pF																			
0.001																			
0.0012µF																			
0.0015µF																			
0.0018µF																			
0.0022µF																			
0.0027µF																			
0.0033µF																			
0.0036µF																			
0.0039µF																			
0.0043µF																			
0.0047µF																			
0.0056µF																			
0.0068µF																			
0.0075µF																			
0.0082µF																			
0.01µF																			
0.012µF																			
0.015µF																			
0.018µF																			
0.022µF																			
0.027µF																			
0.033µF																			
0.036µF																			
0.039µF																			
0.043µF																			
0.047µF																			
0.056µF																			
0.068µF																			
0.082µF																			
0.1µF																			
0.12µF																			
0.15µF																			
0.18µF																			
0.22µF																			
0.27µF																			
0.33µF																			
0.39µF																			
0.47µF																			
0.56µF																			
0.68µF																			
0.82µF																		*	*

* 2.20mm maximum thickness

See NMC High CV series for values above 0.82µF

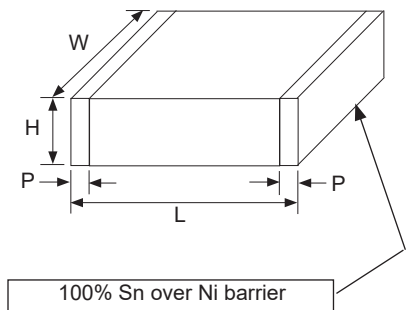

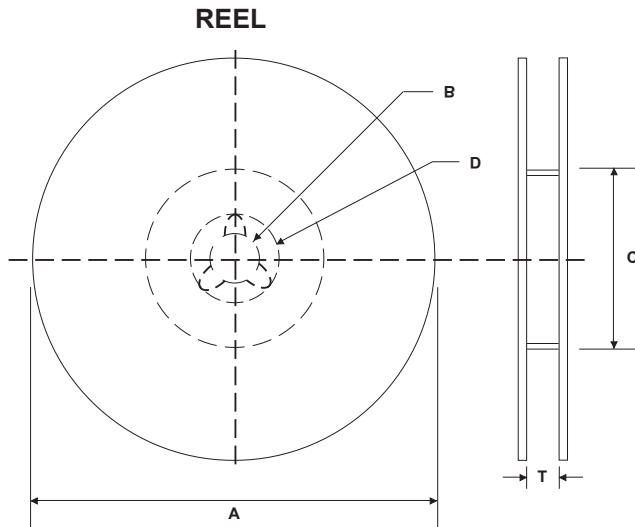

REEL DIMENSIONS (mm)

Reel Diameter (A)	B	C	D	T max.
7" (178 ± 2.0)	13 ± 0.5	50 min.	21 ± 1.0	8.4 +1.0/-0 (1812 case size 12.4 +2.0/-0)
10" (250 ± 2.0)		100 ± 1.0		
13" (330 ± 2.0)		100 ± 1.0		

7 INCH REEL QUANTITIES*

Size	01005	0201	0402	0603	0805	1206	1210	1812
Tape Size	8mm	8mm	8mm	8mm	8mm	8mm	8mm	12mm
Min. Qty Per Reel	20,000	15,000	10,000	4,000	4,000	4,000	2,000	1,000
Max. Qty Per Reel	20,000	15,000	10,000	4,000	5,000	5,000	5,000	2,000

*Quantity dependent on chip thickness. Contact NIC for reel quantities on larger diameter reels.

CARRIER TAPE MATERIAL

Parts with a thickness of $\geq 1\text{mm}$ will be taped on embossed plastic carrier. Parts with a thickness of less than 1mm will be taped on paper carrier

EMBOSSED PLASTIC CARRIER TAPE DIMENSIONS (mm)

Tape Size	W	F	E	P ₀	P ₂	D	K max.	T max.	P
8mm	8.0 ± 0.2	3.5 ± 0.05	1.75 ± 0.10	4.0 ± 0.1	2.0 ± 0.5	1.5 ^{+0.1} _{-0.0}	3.0	2.0	4.0 ± 0.1
12mm	12 ± 0.2	5.5 ± 0.05						4.5	8.0 ± 0.1

Notes:

- Specifications are in compliance with EIA RS481-1-A "Taping of Surface Mount Components for Automatic Placement"
- Dimensions A₀ (max.) equals component width dimension plus 0.5mm
- Dimension B₀ (max.) equals component length dimension plus 0.5mm

EMBOSSED PLASTIC CARRIER TAPE

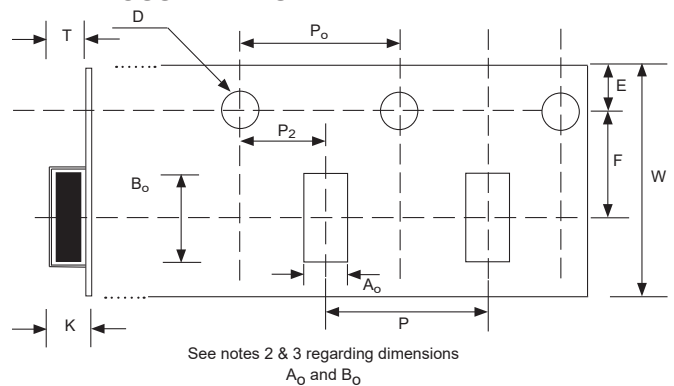

PUNCHED CARRIER TAPE DIMENSIONS (mm)

Type	A ₀	B ₀	W	F	E	P1	P0	D0	T1 max.	T2 max.	Mounting Hole
01005	0.25 ± 0.04	0.45 ± 0.04	8.0 ± 0.3	3.5 ± 0.05	1.75 ± 0.1	2.0 ± 0.05	4.0 ± 0.1	1.5 ^{+0.1} _{-0.0}	0.27	0.36	Angular Punch Hole
0201	0.37 ± 0.03	0.67 ± 0.05							0.45	0.80	
0402	0.65 ± 0.05	1.15 ± 0.05				4.0 ± 0.10			1.1	1.4	
0603	1.1 ± 0.2	1.9 ± 0.2									
0805	1.65 ± 0.2	2.4 ± 0.2									
1206	2.0 ± 0.2	3.6 ± 0.2									

PUNCHED CARRIER TAPE

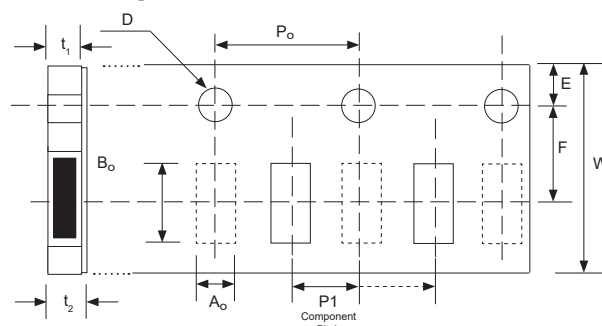

Looking for pricing, stock, or lifecycle information?

Click below to explore more details on WIN SOURCE:

- ⊖ [View NMC0402X7R104K16TRPF on WIN SOURCE](#)
- ⊖ [NIC-Components Corp. Information](#)

Optimize Your Supply Chain with WIN SOURCE Solutions

- ✓ Global Sourcing Solution
- ✓ Obsolete Management
- ✓ Cost Control Management
- ✓ Shortage Management
- ✓ Alternative Solution
- ✓ Excess Inventory Management