



**THE DATASHEET OF
ADL5591ACPZ-R7**



TABLE OF CONTENTS

Features	1	Absolute Maximum Ratings	5
Applications.....	1	ESD Caution.....	5
Functional Block Diagram	1	Pin Configuration and Function Descriptions.....	6
General Description	1	Basic Connections	7
Revision History	2	Outline Dimensions	8
Specifications.....	3	Ordering Guide	8

REVISION HISTORY

4/16—Rev. 0 to Rev. A

Changes to Figure 1	1
Changes to Figure 2.....	6
Changes to Figure 3.....	7
Updated Outline Dimensions	8
Changes to Ordering Guide	8

5/07—Revision 0: Initial Version

SPECIFICATIONS

$V_S = 5\text{ V}$; $T_A = 25^\circ\text{C}$; LO = 2 dBm; baseband I/Q amplitude = 1 V p-p differential sine waves in quadrature with a 1.5 V dc bias; baseband I/Q frequency (f_{BB}) = 1 MHz, unless otherwise noted.

Table 1.

Parameter	Test Conditions/Comments	Min	Typ	Max	Unit
Operating Frequency Range ADL5590		869 1805		960 1990	MHz MHz
ADL5590 @ $f_{\text{RF}} = 880\text{ MHz}$					
Output Power vs. Frequency vs. Temperature	$V_{\text{IQ}} = 1.0\text{ V p-p differential}$ $f_{\text{RF}} = 869\text{ MHz to }894\text{ MHz}$ $0^\circ\text{C to }85^\circ\text{C}$ $-25^\circ\text{C to }0^\circ\text{C}$	3.75	5.9 ± 0.1 0.01 0.01	8.0	dBm dB dB/ $^\circ\text{C}$ dB/ $^\circ\text{C}$
Sideband Suppression			-50		dBc
LO Leakage			-50		dBc
Output Return Loss			2.8		dB
Output P1 dB			16		dBm
Output IP3	$f_{1\text{BB}} = 3.5\text{ MHz}, f_{2\text{BB}} = 4.5\text{ MHz}, P_{\text{OUT}} = 0\text{ dBm per tone}$		29		dBm
Output IP2	$f_{1\text{BB}} = 3.5\text{ MHz}, f_{2\text{BB}} = 4.5\text{ MHz}, P_{\text{OUT}} = 0\text{ dBm per tone}$		66		dBm
Output Noise Density	$P_{\text{OUT}} = 5\text{ dBm}, 6\text{ MHz carrier offset}$		-155		dBc/Hz
Output Noise Floor	Baseband inputs biased to 1.5 V		-156.6		dBm/Hz
Modulation Spectrum	Relative to carrier in 30 kHz, $P_{\text{OUT}} = 3\text{ dBm}, 8\text{ PSK}$ 250 kHz carrier offset 400 kHz carrier offset 600 kHz carrier offset 1.2 MHz carrier offset		-42.5 -71.1 -78.5 -79.1		dBc dBc dBc dBc
RMS Error Vector Magnitude	$P_{\text{OUT}} = 3\text{ dBm}, 8\text{ PSK}$		0.5		%
Peak Error Vector Magnitude	$P_{\text{OUT}} = 3\text{ dBm}, 8\text{ PSK}$		1.5		%
ADL5590 @ $f_{\text{RF}} = 940\text{ MHz}$					
Output Power vs. Frequency vs. Temperature	$V_{\text{IQ}} = 1.0\text{ V p-p differential}$ $f_{\text{RF}} = 925\text{ MHz to }960\text{ MHz}$ $0^\circ\text{C to }85^\circ\text{C}$ $-25^\circ\text{C to }0^\circ\text{C}$	3.5	5.7 ± 0.1 0.01 0.01	7.75	dBm dB dB/ $^\circ\text{C}$ dB/ $^\circ\text{C}$
Sideband Suppression			-50		dBc
LO Leakage			-50		dBc
Output Return Loss			3.2		dB
Output P1 dB			16		dBm
Output IP3	$f_{1\text{BB}} = 3.5\text{ MHz}, f_{2\text{BB}} = 4.5\text{ MHz}, P_{\text{OUT}} = 0\text{ dBm per tone}$		29		dBm
Output IP2	$f_{1\text{BB}} = 3.5\text{ MHz}, f_{2\text{BB}} = 4.5\text{ MHz}, P_{\text{OUT}} = 0\text{ dBm per tone}$		70		dBm
Output Noise Floor	Baseband inputs biased to 1.5 V		-156.6		dBm/Hz
Modulation Spectrum	Relative to carrier in 30 kHz, $P_{\text{OUT}} = 3\text{ dBm}, 8\text{ PSK}$ 250 kHz carrier offset 400 kHz carrier offset 600 kHz carrier offset 1.2 MHz carrier offset		-42.5 -71.1 -78.5 -79.1		dBc dBc dBc dBc
RMS Error Vector Magnitude	$P_{\text{OUT}} = 3\text{ dBm}, 8\text{ PSK}$		0.4		%
Peak Error Vector Magnitude	$P_{\text{OUT}} = 3\text{ dBm}, 8\text{ PSK}$		1.4		%
ADL5591 @ $f_{\text{RF}} = 1850\text{ MHz}$					
Output Power vs. Frequency vs. Temperature	$f_{\text{RF}} = 1850\text{ MHz}$ $V_{\text{IQ}} = 1.0\text{ V p-p differential}$ $f_{\text{RF}} = 1805\text{ MHz to }1880\text{ MHz}$ $0^\circ\text{C to }85^\circ\text{C}$ $-25^\circ\text{C to }0^\circ\text{C}$	3.0	5.0 ± 0.1 0.011 0.011	7.0	dBm dB dB/ $^\circ\text{C}$ dB/ $^\circ\text{C}$
Sideband Suppression			-47		dBc

Parameter	Test Conditions/Comments	Min	Typ	Max	Unit
LO Leakage			-44		dBc
Output Return Loss			5.4		dB
Output P1 dB			16		dBm
Output IP3	$f_{1BB} = 3.5 \text{ MHz}, f_{2BB} = 4.5 \text{ MHz}, P_{OUT} = -1 \text{ dBm per tone}$		30		dBm
Output IP2	$f_{1BB} = 3.5 \text{ MHz}, f_{2BB} = 4.5 \text{ MHz}, P_{OUT} = -1 \text{ dBm per tone}$		60		dBm
Output Noise Density	$P_{OUT} = 5 \text{ dBm}, 6 \text{ MHz carrier offset}$		-156		dBc/Hz
Output Noise Floor	Baseband inputs biased to 1.5 V		-157		dBm/Hz
Modulation Spectrum	Relative to carrier in 30 kHz, $P_{OUT} = 3 \text{ dBm}, 8 \text{ PSK}$				
	250 kHz carrier offset		-42.5		dBc
	400 kHz carrier offset		-71.3		dBc
	600 kHz carrier offset		-79.4		dBc
	1.2 MHz carrier offset		-80.2		dBc
RMS Error Vector Magnitude	$P_{OUT} = 3 \text{ dBm}, 8 \text{ PSK}$		0.5		%
Peak Error Vector Magnitude	$P_{OUT} = 3 \text{ dBm}, 8 \text{ PSK}$		1.7		%
ADL5591 @ $f_{RF} = 1960 \text{ MHz}$					
Output Power	$V_{IQ} = 1.0 \text{ V p-p differential}$	2.5	4.7	6.5	dBm
vs. Frequency	$f_{RF} = 1930 \text{ MHz to } 1990 \text{ MHz}$		± 0.1		dB
vs. Temperature	$0^\circ\text{C to } 85^\circ\text{C}$		+0.011		dB/ $^\circ\text{C}$
	$-25^\circ\text{C to } 0^\circ\text{C}$		+0.011		dB/ $^\circ\text{C}$
Sideband Suppression			-48		dBc
LO Leakage			-44		dBc
Output Return Loss			6.0		dB
Output P1dB			16		dBm
Output IP3	$f_{1BB} = 3.5 \text{ MHz}, f_{2BB} = 4.5 \text{ MHz}, P_{OUT} = -1 \text{ dBm per tone}$		30		dBm
Output IP2	$f_{1BB} = 3.5 \text{ MHz}, f_{2BB} = 4.5 \text{ MHz}, P_{OUT} = -1 \text{ dBm per tone}$		60		dBm
Output Noise Density	$P_{OUT} = 5 \text{ dBm}, 6 \text{ MHz carrier offset}$		-156		dBc/Hz
Output Noise Floor	Baseband inputs biased to 1.5 V		157		dBm/Hz
Modulation Spectrum	Relative to carrier in 30 kHz, $P_{OUT} = 3 \text{ dBm}, 8 \text{ PSK}$				
	250 kHz carrier offset		-42.5		dBc
	400 kHz carrier offset		-71.4		dBc
	600 kHz carrier offset		-79.7		dBc
	1.2 MHz carrier offset		-80.5		dBc
RMS Error Vector Magnitude	$P_{OUT} = 3 \text{ dBm}, 8 \text{ PSK}$		0.5		%
Peak Error Vector Magnitude	$P_{OUT} = 3 \text{ dBm}, 8 \text{ PSK}$		1.6		%
LO INPUTS	LOIP, LOIN				
LO Drive Level ¹		-1	+2	+5	dBm
Input Return Loss	ADL5590 @ $f_{RF} = 880 \text{ MHz}$		7.5		dB
	ADL5591 @ $f_{RF} = 1850 \text{ MHz}$		10.7		dB
BASEBAND INPUTS	Pins IBBP, IBBN, QBBP, QBBN				
I and Q Input Bias Level			1.5		V
Bandwidth (3 dB)			250		MHz
Differential Input Impedance			9		k Ω
POWER SUPPLIES	Pin VPS1 to Pin VPS5				
Voltage	Full specification	4.75		5.25	V
	Degraded specification	4.5		5.5	V
Supply Current			170		mA
ADL5590			170		mA

¹ LO drive in excess of 5 dBm can be provided to further reduce noise at 6 MHz carrier offset.

ABSOLUTE MAXIMUM RATINGS

Table 2.

Parameter	Rating
Supply Voltage, VPS1 to VPS5	5.5 V
IBBP, IBBN, QBBP, QBBN	0 V, 3 V
LOIP	10 dBm
Internal Power Dissipation	1155 mW
θ_{JA} (Exposed Pad Soldered Down)	40°C/W
Maximum Junction Temperature	132°C
Operating Temperature Range	-40°C to +85°C
Storage Temperature Range	-65°C to +150°C
Maximum Soldering Temperature	260°C

Stresses at or above those listed under Absolute Maximum Ratings may cause permanent damage to the product. This is a stress rating only; functional operation of the product at these or any other conditions above those indicated in the operational section of this specification is not implied. Operation beyond the maximum operating conditions for extended periods may affect product reliability.

ESD CAUTION



ESD (electrostatic discharge) sensitive device. Charged devices and circuit boards can discharge without detection. Although this product features patented or proprietary protection circuitry, damage may occur on devices subjected to high energy ESD. Therefore, proper ESD precautions should be taken to avoid performance degradation or loss of functionality.

PIN CONFIGURATION AND FUNCTION DESCRIPTIONS

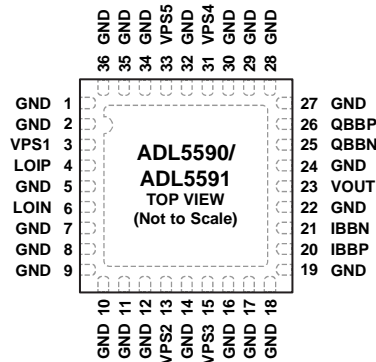

NOTES
 1. EXPOSED PAD. CONNECT THE EXPOSED PAD TO THE GROUND PLANE VIA A LOW IMPEDANCE PATH.

0986-1-002

Figure 2. Pin Configuration

Table 3. Pin Function Descriptions

Pin No.	Mnemonic	Description
1, 2, 5, 7 to 12, 14, 16 to 19, 22, 24, 27 to 30, 32, 34 to 36	GND	Ground. Connect to ground plane via a low impedance path.
3, 13, 15, 31, 33	VPS1, VPS2, VPS3, VPS4, VPS5	Positive Supply Voltage. Connect all pins to the same supply. To ensure adequate external bypassing, connect 0.1 μ F capacitors between each pin and ground.
4, 6	LOIP, LOIN	Local Oscillator Input. 50 Ω single-ended local oscillator input. Pins must be ac-coupled. AC-couple LOIN to ground and drive LO through LOIP.
20, 21, 25, 26	IBBP, IBBN, QBBN, QBBP	Baseband Inputs. Differential in-phase and quadrature baseband inputs. These high impedance inputs must be dc-biased to approximately 1.5 V dc. These inputs are not self-biased and must be externally biased.
23	VOUT	RF Output. Single-ended, 50 Ω , internally biased RF output. Pin must be ac-coupled to the load.
	Exposed Pad	Exposed Pad. Connect the exposed pad to the ground plane via a low impedance path.

BASIC CONNECTIONS

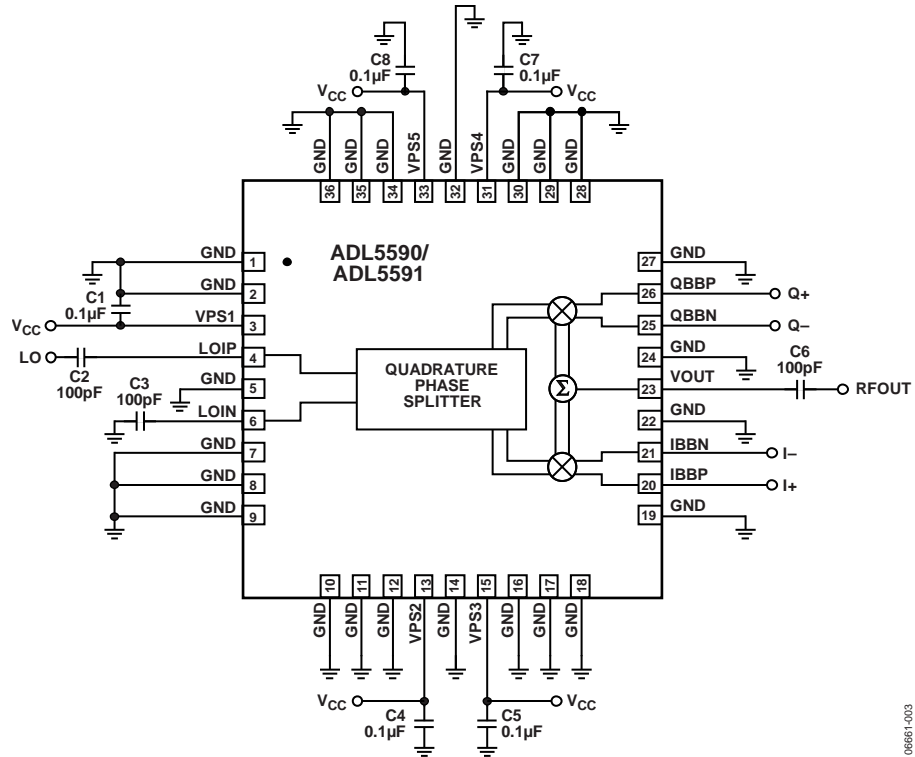
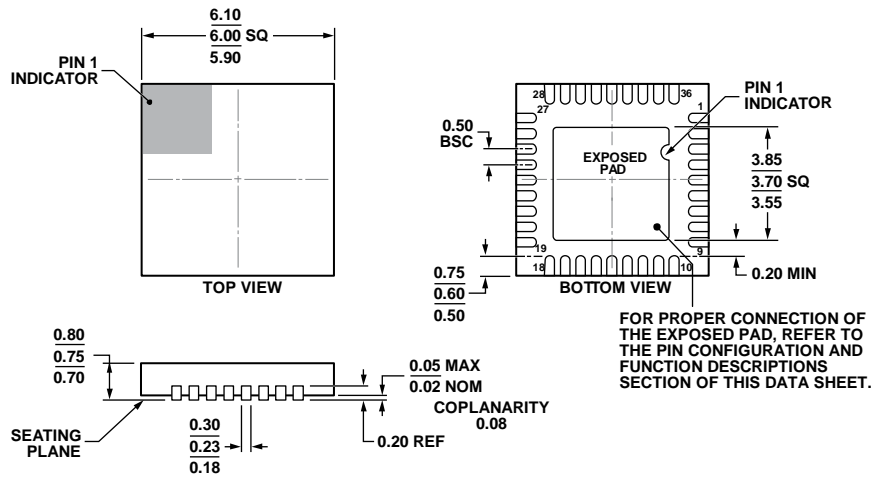

Figure 3. Basic Connections for Operation

06661-003

OUTLINE DIMENSIONS



COMPLIANT TO JEDEC STANDARDS MO-220-WJJD-1.

Figure 4. 36-Lead Lead Frame Chip Scale Package [LFCSP]
6 mm × 6 mm Body and 0.75 mm Package Height
(CP-36-4)

Dimensions shown in millimeters

01-26-2010-A

ORDERING GUIDE

Model ¹	Temperature Range	Package Description	Package Option
ADL5590ACPZ-R7	-40°C to +85°C	36-Lead LFCSP, 7" Tape and Reel	CP-36-4
ADL5591ACPZ-R7	-40°C to +85°C	36-Lead LFCSP, 7" Tape and Reel	CP-36-4

¹ Z = RoHS Compliant Part.

Looking for pricing, stock, or lifecycle information?

Click below to explore more details on WIN SOURCE:

 [View ADL5591ACPZ-R7 on WIN SOURCE](#)

 [Analog Devices Inc. Information](#)

Optimize Your Supply Chain with WIN SOURCE Solutions

-  Global Sourcing Solution
-  Obsolete Management
-  Cost Control Management
-  Shortage Management
-  Alternative Solution
-  Excess Inventory Management