



**THE DATASHEET OF  
ADL5370ACPZ-R7**



### FEATURES

**Output frequency range: 300 MHz to 1000 MHz**  
**Modulation bandwidth: >500 MHz (3 dB)**  
**1 dB output compression: 11 dBm @ 450 MHz**  
**Noise floor: -160 dBm/Hz**  
**Sideband suppression: -41 dBc @ 450 MHz**  
**Carrier feedthrough: -50 dBm @ 450 MHz**  
**Single supply: 4.75 V to 5.25 V**  
**24-lead LFCSP\_VQ package**

### APPLICATIONS

**Cellular communication systems at 450 MHz**  
**CDMA2000/GSM**  
**WiMAX/broadband wireless access systems**  
**Cable communication equipment**  
**Satellite modems**

### GENERAL DESCRIPTION

The ADL5370 is the first in the fixed-gain quadrature modulator (F-MOD) family designed for use from 300 MHz to 1000 MHz. Its excellent phase accuracy and amplitude balance enable high performance intermediate frequency or direct radio frequency modulation for communication systems.

The ADL5370 provides a greater than 500 MHz, 3 dB baseband bandwidth, making it ideally suited for use in broadband zero IF or low IF-to-RF applications and in broadband digital predistortion transmitters.

### FUNCTIONAL BLOCK DIAGRAM

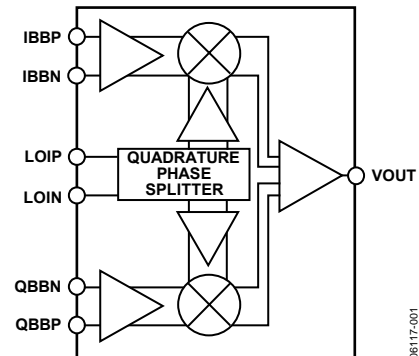

Figure 1.

The ADL5370 accepts two differential baseband inputs and a single-ended LO and generates a single-ended 50  $\Omega$  output.

The ADL5370 is fabricated using the Analog Devices, Inc. advanced silicon-germanium bipolar process. It is available in a 24-lead, exposed-paddle, Pb-free, LFCSP\_VQ package. Performance is specified over a  $-40^{\circ}\text{C}$  to  $+85^{\circ}\text{C}$  temperature range. A Pb-free evaluation board is available.

#### Rev. 0

Information furnished by Analog Devices is believed to be accurate and reliable. However, no responsibility is assumed by Analog Devices for its use, nor for any infringements of patents or other rights of third parties that may result from its use. Specifications subject to change without notice. No license is granted by implication or otherwise under any patent or patent rights of Analog Devices. Trademarks and registered trademarks are the property of their respective owners.

## TABLE OF CONTENTS

Features .....	1	Applications Information .....	13
Applications.....	1	DAC Modulator Interfacing .....	13
Functional Block Diagram .....	1	Limiting the AC Swing .....	13
General Description .....	1	Filtering.....	13
Revision History .....	2	Using the AD9779 Auxiliary DAC for Carrier Feedthrough Nulling .....	14
Specifications.....	3	GSM Operation .....	14
Absolute Maximum Ratings.....	4	LO Generation Using PLLs .....	15
ESD Caution.....	4	Evaluation Board .....	16
Pin Configuration and Function Descriptions.....	5	Characterization Setup .....	17
Theory of Operation .....	10	Outline Dimensions .....	19
Circuit Description.....	10	Ordering Guide .....	19
Basic Connections .....	11		
Optimization .....	12		

## REVISION HISTORY

10/06—Revision 0: Initial Version

## SPECIFICATIONS

$V_S = 5\text{ V}$ ;  $T_A = 25^\circ\text{C}$ ; LO = 0 dBm<sup>1</sup> single-ended; baseband I/Q amplitude = 1.4 V p-p differential sine waves in quadrature with a 500 mV dc bias; baseband I/Q frequency ( $f_{\text{BB}}$ ) = 1 MHz, unless otherwise noted.

**Table 1.**

Parameter	Conditions	Min	Typ	Max	Unit
ADL5370	LO = 450 MHz				
Operating Frequency Range	Range over which uncompensated sideband suppression < -30 dBc				
	Low frequency		300		MHz
	High frequency		1000		MHz
Output Power	$V_{\text{IQ}} = 1.4\text{ V p-p differential}$		6.2		dBm
Output P1 dB			11		dBm
Carrier Feedthrough			-50		dBm
Sideband Suppression			-41		dBc
Quadrature Error			0.76		Degrees
I/Q Amplitude Balance			0.03		dB
Second Harmonic	$P_{\text{OUT}} - (f_{\text{LO}} + (2 \times f_{\text{BB}}))$ , $P_{\text{OUT}} = 6.2\text{ dBm}$		-65		dBc
Third Harmonic	$P_{\text{OUT}} - (f_{\text{LO}} + (3 \times f_{\text{BB}}))$ , $P_{\text{OUT}} = 6.2\text{ dBm}$		-54		dBc
Output IP2	$f_{1\text{BB}} = 3.5\text{ MHz}$ , $f_{2\text{BB}} = 4.5\text{ MHz}$ , $P_{\text{OUT}} = -2\text{ dBm per tone}$		60		dBm
Output IP3	$f_{1\text{BB}} = 3.5\text{ MHz}$ , $f_{2\text{BB}} = 4.5\text{ MHz}$ , $P_{\text{OUT}} = -2\text{ dBm per tone}$		24		dBm
Noise Floor	I/Q inputs = 0 V differential with a 500 mV common-mode bias, 20 MHz carrier offset		-160		dBm/Hz
GSM	6 MHz carrier offset, $P_{\text{OUT}} = 6\text{ dBm}$ , $P_{\text{LO}} = 6\text{ dBm}$		-157		dBc/Hz
LO INPUTS					
LO Drive Level <sup>1</sup>	Characterization performed at typical level	-7	0	+7	dBm
Input Return Loss	See Figure 9 for a plot of return loss vs. frequency		6		dB
BASEBAND INPUTS	Pin IBBP, Pin IBBN, Pin QBBP, Pin QBNN				
I and Q Input Bias Level			500		mV
Input Bias Current	Current sourcing from each baseband input with a bias of 500 mV dc <sup>2</sup>		45		$\mu\text{A}$
Input Offset Current			0.1		$\mu\text{A}$
Differential Input Impedance			2900		k $\Omega$
Bandwidth (0.1 dB)	LO = 450 MHz, baseband input = 700 mV p-p sine wave on 500 mV dc		70		MHz
Bandwidth (1 dB)	LO = 450 MHz, baseband input = 700 mV p-p sine wave on 500 mV dc		350		MHz
POWER SUPPLIES	Pin VPS1 and Pin VPS2				
Voltage		4.75		5.25	V
Supply Current			205		mA

<sup>1</sup> High LO drive reduces noise at a 6 MHz carrier offset in GSM applications.

<sup>2</sup> See V-to-I converter discussion in the Circuit Description section for architecture information.

## ABSOLUTE MAXIMUM RATINGS

Table 2.

Parameter	Rating
Supply Voltage VPOS	5.5 V
IBBP, IBBN, QBBP, QBBN	0 V to 2 V
LOIP and LOIN	13 dBm
Internal Power Dissipation	1375 mW
$\theta_{JA}$ (Exposed Paddle Soldered Down)	54°C/W
Maximum Junction Temperature	159°C
Operating Temperature Range	-40°C to +85°C
Storage Temperature Range	-65°C to +150°C

Stresses above those listed under Absolute Maximum Ratings may cause permanent damage to the device. This is a stress rating only; functional operation of the device at these or any other conditions above those indicated in the operational section of this specification is not implied. Exposure to absolute maximum rating conditions for extended periods may affect device reliability.

### ESD CAUTION



**ESD (electrostatic discharge) sensitive device.** Charged devices and circuit boards can discharge without detection. Although this product features patented or proprietary protection circuitry, damage may occur on devices subjected to high energy ESD. Therefore, proper ESD precautions should be taken to avoid performance degradation or loss of functionality.

## PIN CONFIGURATION AND FUNCTION DESCRIPTIONS

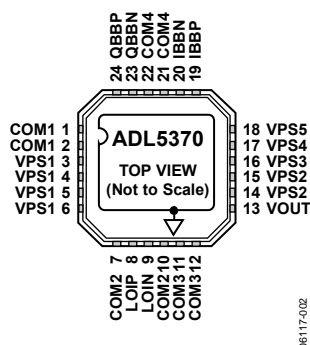

Figure 2. Pin Configuration

Table 3. Pin Function Descriptions

Pin No.	Mnemonic	Description
1, 2, 7, 10 to 12, 21, 22	COM1, COM2, COM3, COM4	Input Common Pins. Connect to ground plane via a low impedance path.
3 to 6, 14 to 18	VPS1, VPS2, VPS3, VPS4, VPS5	Positive Supply Voltage Pins. All pins should be connected to the same supply ( $V_S$ ). To ensure adequate external bypassing, connect 0.1 $\mu$ F capacitors between each pin and ground. Adjacent power supply pins of the same name can share one capacitor (see Figure 25).
19, 20, 23, 24	IBBP, IBBN, QBPN, QBPN	Differential In-Phase and Quadrature Baseband Inputs. These high impedance inputs must be dc-biased to 500 mV dc, and must be driven from a low impedance source. Nominal characterized ac signal swing is 700 mV p-p on each pin. This results in a differential drive of 1.4 V p-p with a 500 mV dc bias. These inputs are not self-biased and must be externally biased.
8, 9	LOIP, LOIN	50 $\Omega$ Single-Ended Local Oscillator Input. Internally dc-biased. Pins must be ac-coupled. AC-couple LOIN to ground and drive LO through LOIP.
13	VOUT Exposed Paddle	Device Output. Single-ended, 50 $\Omega$ internally biased RF output. Pin must be ac-coupled to the load. Connect to ground plane via a low impedance path.

## TYPICAL PERFORMANCE CHARACTERISTICS

$V_S = 5\text{ V}$ ;  $T_A = 25^\circ\text{C}$ ; LO = 0 dBm single-ended; baseband I/Q amplitude = 1.4 V p-p differential sine waves in quadrature with a 500 mV dc bias; baseband I/Q frequency ( $f_{\text{BB}}$ ) = 1 MHz, unless otherwise noted.

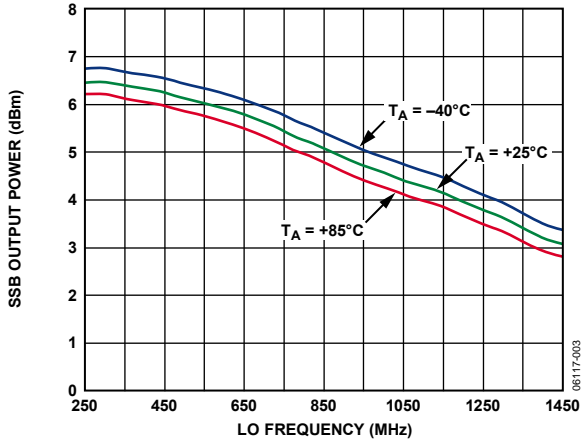

Figure 3. Single Sideband (SSB) Output Power ( $P_{\text{OUT}}$ ) vs. LO Frequency ( $f_{\text{LO}}$ ) and Temperature

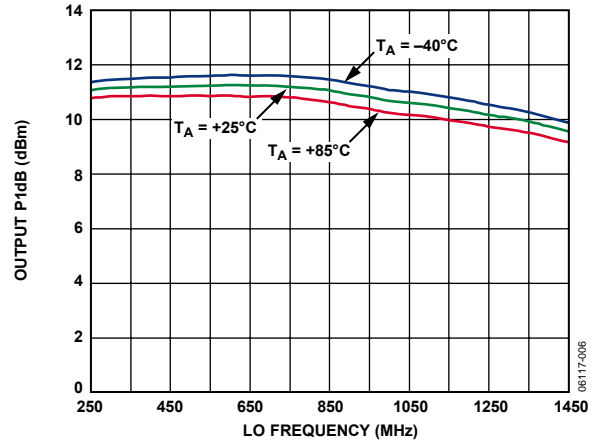

Figure 6. SSB Output 1 dB Compression Point ( $OP_{1\text{dB}}$ ) vs.  $f_{\text{LO}}$  and Temperature

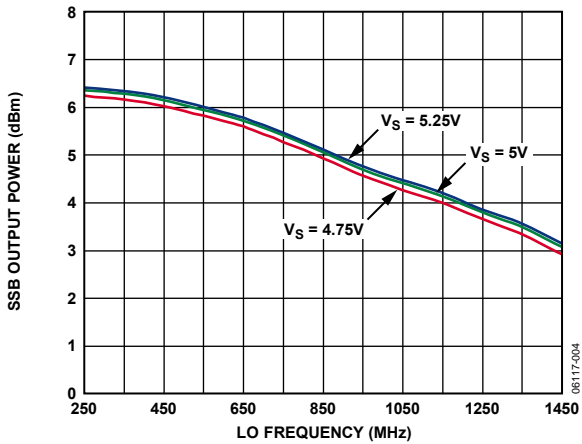

Figure 4. Single Sideband (SSB) Output Power ( $P_{\text{OUT}}$ ) vs. LO Frequency ( $f_{\text{LO}}$ ) and Supply

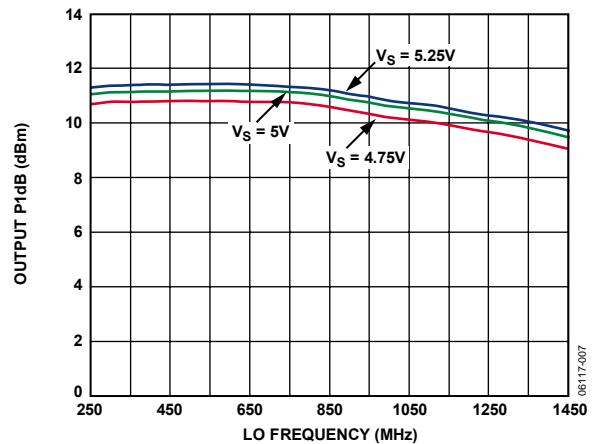

Figure 7. SSB Output 1 dB Compression Point ( $OP_{1\text{dB}}$ ) vs.  $f_{\text{LO}}$  and Supply

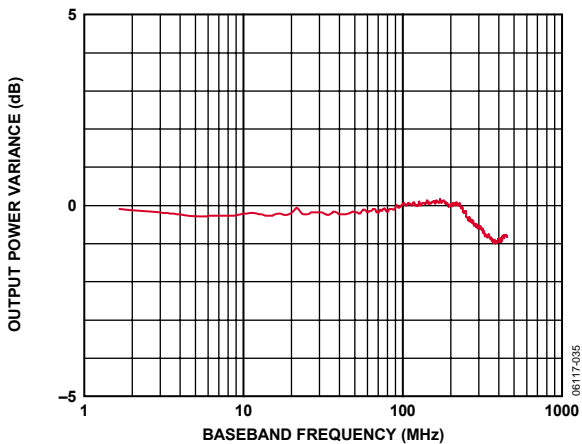

Figure 5. I and Q Input Bandwidth Normalized to Gain @ 1 MHz ( $f_{\text{LO}} = 500\text{ MHz}$ )

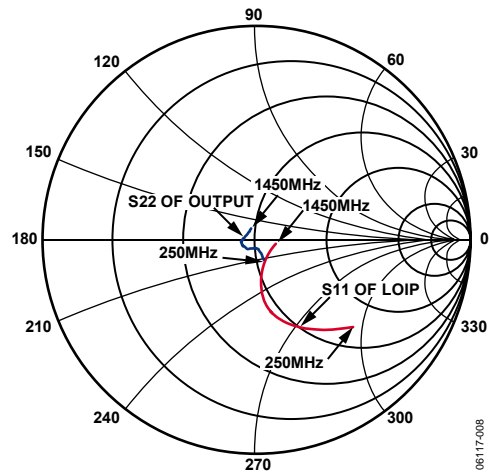

Figure 8. Smith Chart of LOIP S11 and VOUT S22. ( $f_{\text{LO}}$  from 250 MHz to 1450 MHz)

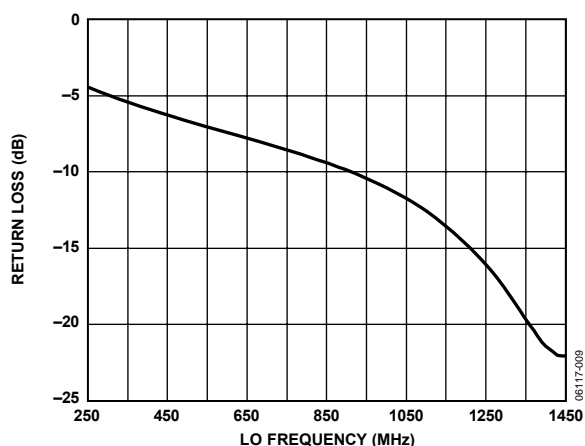

Figure 9. Return Loss (S11) of LOIP

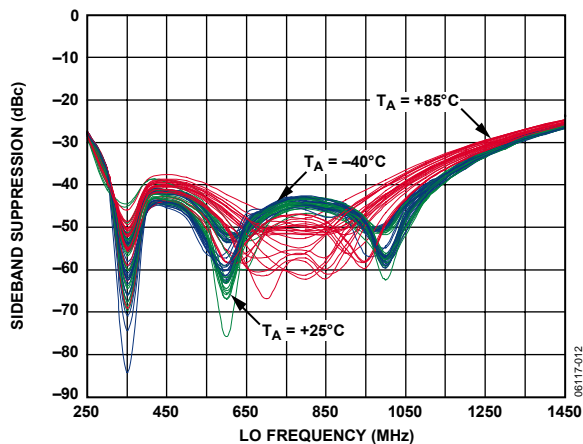

Figure 12. Sideband Suppression vs.  $f_{LO}$  and Temperature  
Multiple Devices Shown

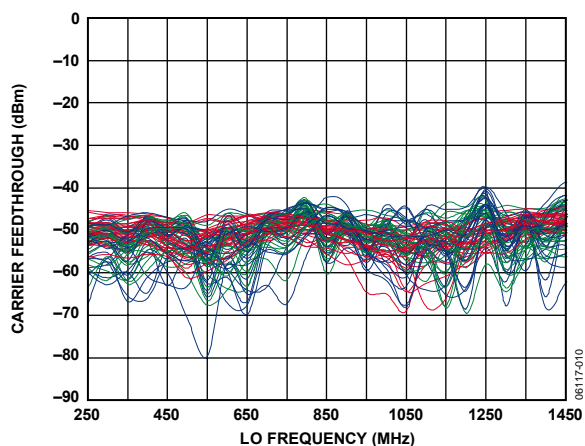

Figure 10. Carrier Feedthrough vs.  $f_{LO}$  and Temperature  
Multiple Devices Shown

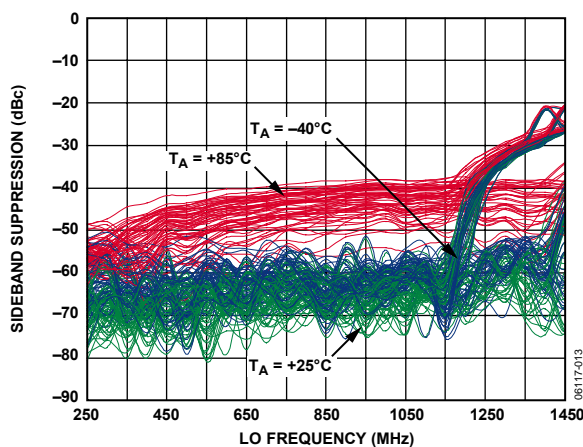

Figure 13. Sideband Suppression vs.  $f_{LO}$  and Temperature after Nulling at 25°C  
Multiple Devices Shown

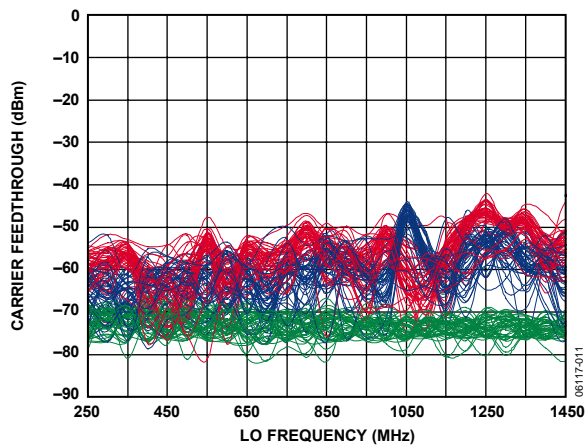

Figure 11. Carrier Feedthrough vs.  $f_{LO}$  and Temperature after Nulling at 25°C  
Multiple Devices Shown

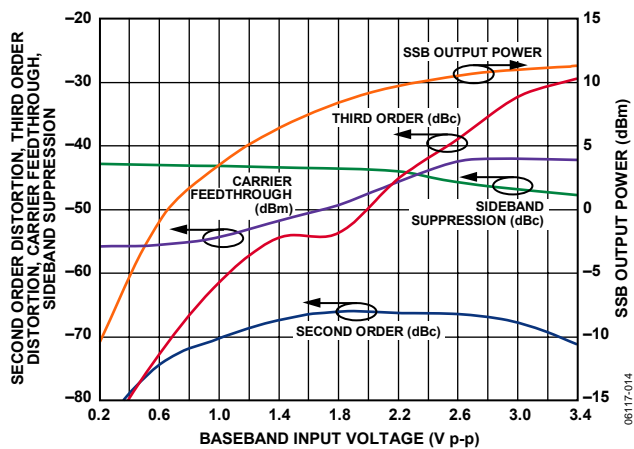

Figure 14. Second- and Third-Order Distortion, Carrier Feedthrough, Sideband Suppression, and SSB  $P_{OUT}$  vs. Baseband Differential Input Level ( $f_{LO} = 450$  MHz)

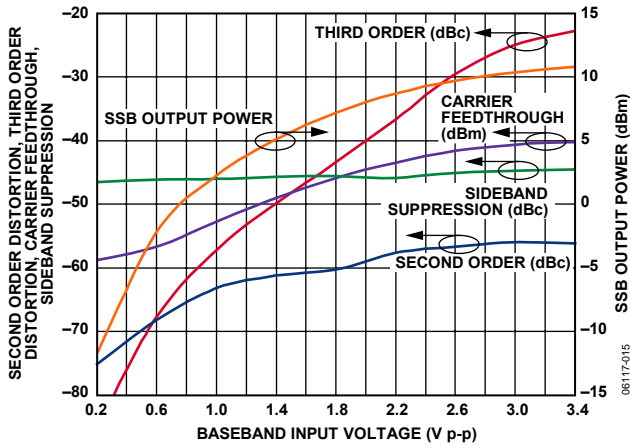

Figure 15. Second- and Third-Order Distortion, Carrier Feedthrough, Sideband Suppression, and SSB  $P_{OUT}$  vs. Baseband Differential Input Level ( $f_{LO} = 900$  MHz)

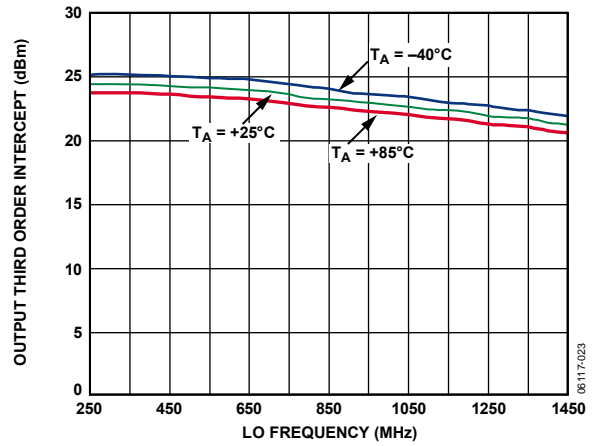

Figure 18. OIP3 vs. Frequency and Temperature

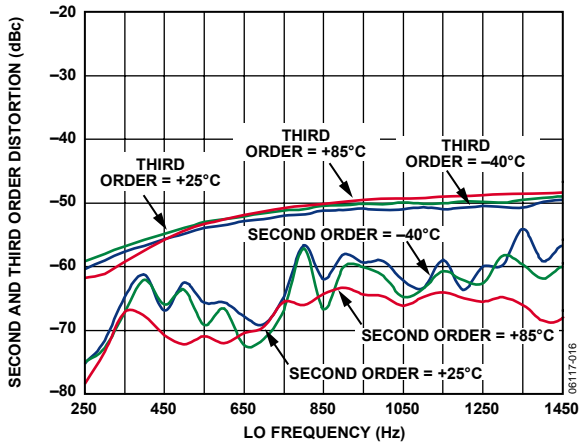

Figure 16. Second- and Third-Order Distortion vs.  $f_{LO}$  and Temperature (Baseband I/Q Amplitude = 1.4 V p-p differential)

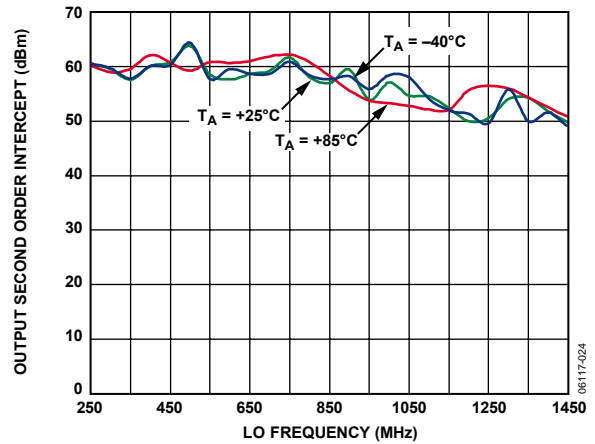

Figure 19. OIP2 vs. Frequency and Temperature

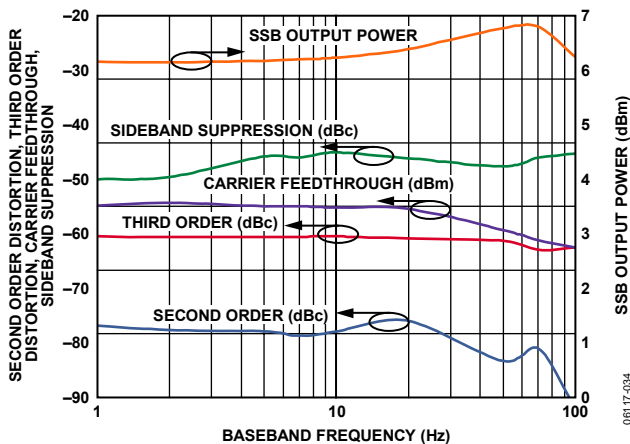

Figure 17. Second- and Third-Order Distortion, Carrier Feedthrough, Sideband Suppression, and SSB  $P_{OUT}$  vs.  $f_{BB}$  and Temperature ( $f_{LO} = 450$  MHz)

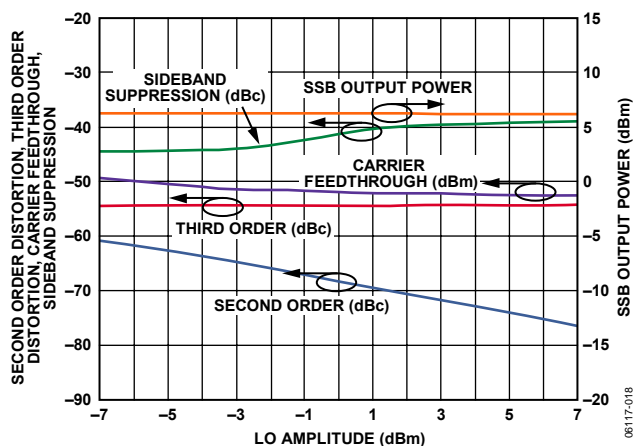

Figure 20. Second- and Third-Order Distortion, Carrier Feedthrough, Sideband Suppression, and SSB  $P_{OUT}$  vs. LO Amplitude ( $f_{LO} = 450$  MHz)

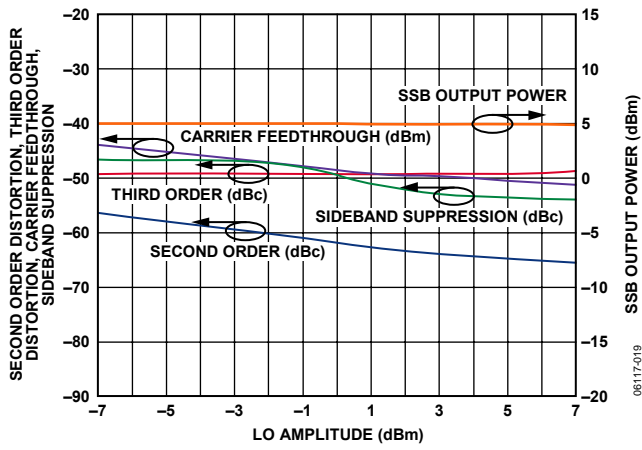

Figure 21. Second- and Third-Order Distortion, Carrier Feedthrough, Sideband Suppression, and SSB  $P_{OUT}$  vs. LO Amplitude ( $f_{LO} = 900$  MHz)

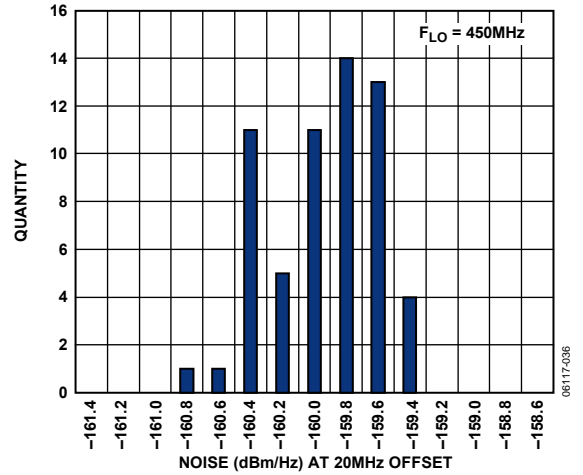

Figure 23. 20 MHz Offset Noise Floor Distribution at  $f_{LO} = 450$  MHz (I/Q Amplitude = 0 mV p-p with 500 mV dc bias)

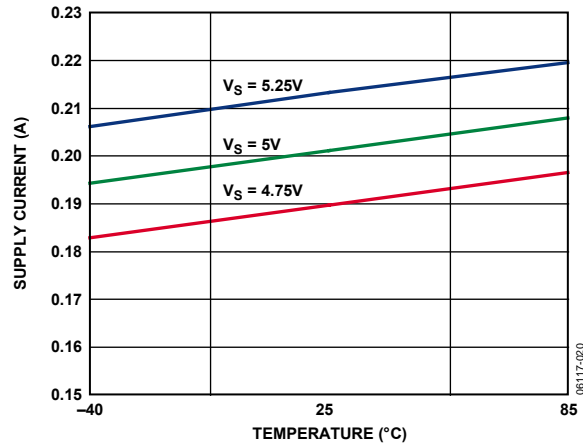

Figure 22. Power Supply Current vs. Temperature

## THEORY OF OPERATION

### CIRCUIT DESCRIPTION

#### Overview

The ADL5370 can be divided into five circuit blocks: the local oscillator (LO) interface, the baseband voltage-to-current (V-to-I) converter, the mixers, the differential-to-single-ended (D-to-S) amplifier, and the bias circuit. A detailed block diagram of the device is shown in Figure 24.

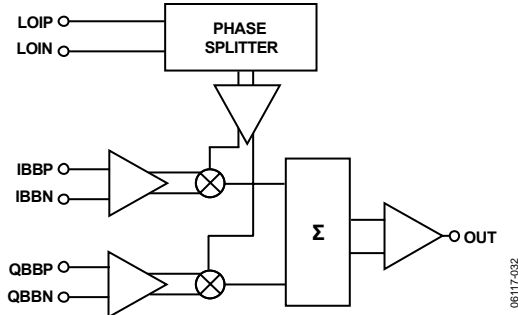

Figure 24. Block Diagram

The LO interface generates two LO signals in quadrature. These signals are used to drive the mixers. The I and Q baseband input signals are converted to currents by the V-to-I stages, which then drive the two mixers. The outputs of these mixers combine to feed the differential-to-single-ended amplifier, which provides a 50  $\Omega$  output interface. The bias cell generates reference currents for the V-to-I stage and the D-to-S amplifier.

#### LO Interface

The LO interface consists of a polyphase quadrature splitter followed by a limiting amplifier. The LO input impedance is set by the polyphase. The LO can be driven either single-ended or differentially. When driven single-ended, the LOIN pin should be ac-grounded via a capacitor. Each quadrature LO signal then passes through a limiting amplifier that provides the mixer with a limited drive signal.

#### V-to-I Converter

The differential baseband inputs (QBBP, QBPN, IBBN, IBBP) consist of the bases of PNP transistors, which present a high impedance. The voltages applied to these pins drive the V-to-I stage that converts baseband voltages into currents. The differential output currents of the V-to-I stages feed each of their respective Gilbert-cell mixers. The dc common-mode voltage at the baseband inputs sets the currents in the two mixer cores. Varying the baseband common-mode voltage varies the current in the mixer and affects overall modulator performance. The recommended dc voltage for the baseband common-mode voltage is 500 mV dc.

#### Mixers

The ADL5370 has two double-balanced mixers: one for the in-phase channel (I channel) and one for the quadrature channel (Q channel). Both mixers are based on the Gilbert-cell design of four cross-connected transistors. The output currents from the two mixers sum together into a load. The signal developed across this load is used to drive the D-to-S amplifier.

#### D-to-S Amplifier

The output D-to-S amplifier consists of a totem pole output stage. The 50  $\Omega$  output impedance is established by an on-chip resistor. The D-to-S output is internally dc-biased and should be ac-coupled at its output (VOUT).

#### Bias Circuit

An on-chip band gap reference circuit is used to generate a proportional-to-absolute temperature (PTAT) reference current for the V-to-I stage and a temperature independent current for the D-to-S output stage.

## BASIC CONNECTIONS

Figure 25 shows the basic connections for the ADL5370.

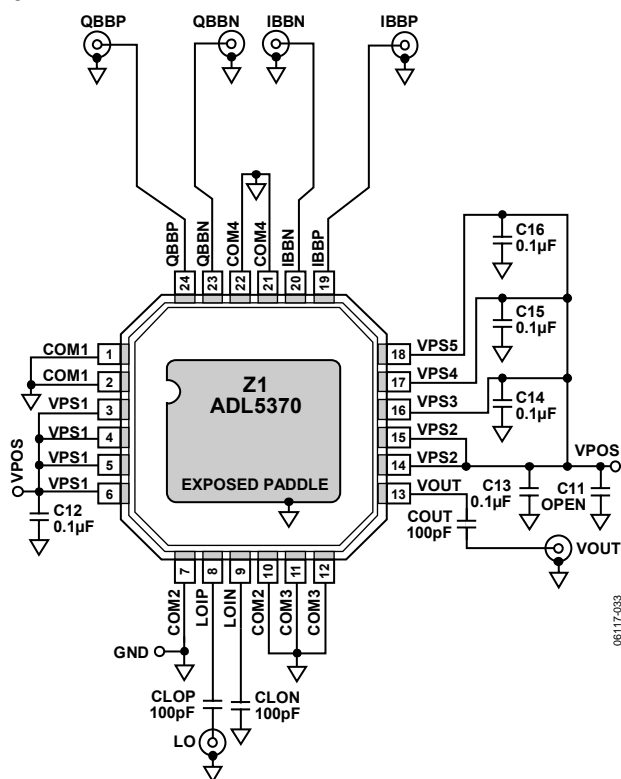

Figure 25. Basic Connections for the ADL5370

### Power Supply and Grounding

All the VPS pins must be connected to the same 5 V source. Adjacent pins of the same name can be tied together and decoupled with a 0.1  $\mu\text{F}$  capacitor. These capacitors should be located as close as possible to the device. The power supply can range between 4.75 V and 5.25 V.

The COM1 pin, COM2 pin, COM3 pin, and COM4 pin should be tied to the same ground plane through low impedance paths. The exposed paddle on the underside of the package should also be soldered to a low thermal and electrical impedance ground plane. If the ground plane spans multiple layers on the circuit board, they should be stitched together with nine vias under the exposed paddle. The Analog Devices [AN-772](#) application note discusses the thermal and electrical grounding of the LFCSP\_VQ in greater detail.

### Baseband Inputs

The baseband inputs QBBP, QBBN, IBBP, and IBBN must be driven from a differential source. The nominal drive level of 1.4 V p-p differential (700 mV p-p on each pin) should be biased to a common-mode level of 500 mV dc.

The dc common-mode bias level for the baseband inputs may range from 400 mV to 600 mV. This results in a reduction in the usable input ac swing range. The nominal dc bias of 500 mV allows for the largest ac swing, limited on the bottom end by the ADL5370 input range and on the top end by the output compliance range on most digital-to-analog converters (DAC) from Analog Devices.

### LO Input

A single-ended LO signal should be applied to the LOIP pin through an ac-coupling capacitor. The recommended LO drive power is 0 dBm. The LO return pin, LOIN, should be ac-coupled to ground through a low impedance path.

The nominal LO drive of 0 dBm can be increased to up to 7 dBm to realize an improvement in the noise performance of the modulator. This improvement is tempered by degradation in the sideband suppression performance (see Figure 20) and, therefore, should be used judiciously. If the LO source cannot provide the 0 dBm level, then operation at a reduced power below 0 dBm is acceptable. Reduced LO drive results in slightly increased modulator noise. The effect of LO power on sideband suppression and carrier feedthrough is shown in Figure 20. The effect of LO power on GSM noise is shown in Figure 35.

### RF Output

The RF output is available at the VOUT pin (Pin 13). This pin must also be ac-coupled. The VOUT pin has a nominal broadband impedance of 50  $\Omega$  and does not need further external matching.

## OPTIMIZATION

The carrier feedthrough and sideband suppression performance of the ADL5370 can be improved through the use of optimization techniques.

### Carrier Feedthrough Nulling

Carrier feedthrough results from minute dc offsets that occur between each of the differential baseband inputs. In an ideal modulator the quantities  $(V_{IOPP} - V_{IOPN})$  and  $(V_{QOPP} - V_{QOPN})$  are equal to zero, and this results in no carrier feedthrough. In a real modulator, those two quantities are nonzero; and, when mixed with the LO, they result in a finite amount of carrier feedthrough. The ADL5370 is designed to provide a minimal amount of carrier feedthrough. Should even lower carrier feedthrough levels be required, minor adjustments can be made to the  $(V_{IOPP} - V_{IOPN})$  and  $(V_{QOPP} - V_{QOPN})$  offsets. The I-channel offset is held constant while the Q-channel offset is varied, until a minimum carrier feedthrough level is obtained. The Q-channel offset required to achieve this minimum is held constant while the offset on the I-channel is adjusted, until a new minimum is reached. Through two iterations of this process, the carrier feedthrough can be reduced to as low as the output noise. The ability to null is sometimes limited by the resolution of the offset adjustment. Figure 26 shows the relationship of carrier feedthrough vs. dc offset as null.

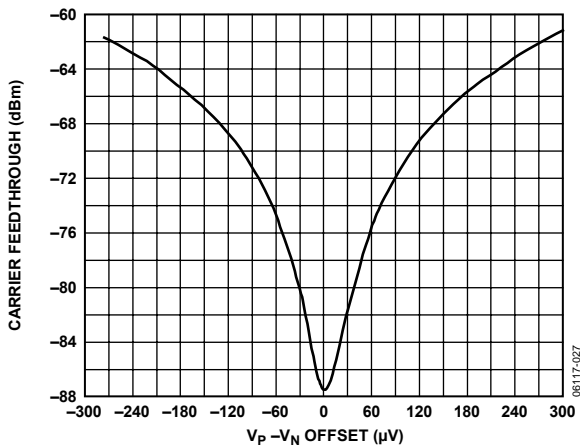

Figure 26. Carrier Feedthrough vs. DC Offset Voltage at 450 MHz

Note that throughout the nulling process, the dc bias for the baseband inputs remains at 500 mV. When no offset is applied

$$V_{IOPP} = V_{IOPN} = 500 \text{ mV, or}$$

$$V_{IOPP} - V_{IOPN} = V_{IOS} = 0 \text{ V}$$

When an offset of  $+V_{IOS}$  is applied to the I-channel inputs

$$V_{IOPP} = 500 \text{ mV} + V_{IOS}/2, \text{ and}$$

$$V_{IOPN} = 500 \text{ mV} - V_{IOS}/2, \text{ such that}$$

$$V_{IOPP} - V_{IOPN} = V_{IOS}$$

The same applies to the Q channel.

It is often desirable to perform a one-time carrier null calibration. This is usually performed at a single frequency. Figure 27 shows how carrier feedthrough varies with LO frequency over a range of  $\pm 50$  MHz on either side of a null at 450 MHz.

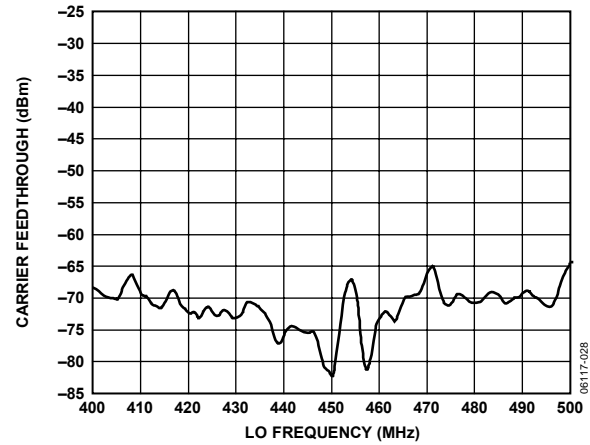

Figure 27. Carrier Feedthrough vs. Frequency After Nulling at 450 MHz

### Sideband Suppression Optimization

Sideband suppression results from relative gain and relative phase offsets between the I and Q channels and can be suppressed through adjustments to those two parameters. Figure 28 illustrates how sideband suppression is affected by the gain and phase imbalances.

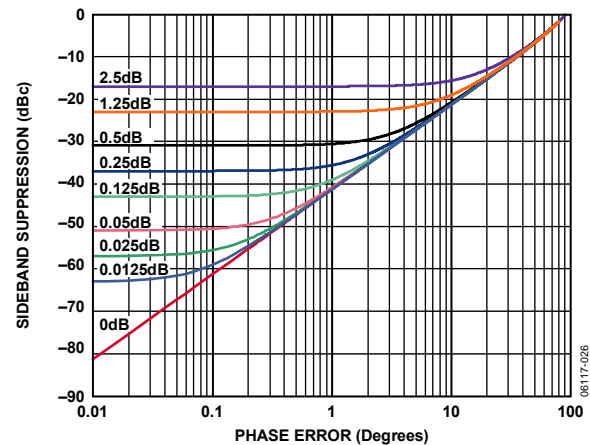

Figure 28. Sideband Suppression vs. Quadrature Phase Error for Various Quadrature Amplitude Offsets

Figure 28 underlines the fact that adjusting only one parameter improves the sideband suppression only to a point, unless the other parameter is also adjusted. For example, if the amplitude offset is 0.25 dB, improving the phase imbalance better than  $1^\circ$  does not yield any improvement in the sideband suppression. For optimum sideband suppression, an iterative adjustment between phase and amplitude is required.

The sideband suppression nulling can be performed either through adjusting the gain for each channel or through the modification of the phase and gain of the digital data coming from the digital signal processor.

## APPLICATIONS INFORMATION

### DAC MODULATOR INTERFACING

The ADL5370 is designed to interface with minimal components to members of the Analog Devices family of DACs. These DACs feature an output current swing from 0 to 20 mA, and the interface described in this section can be used with any DAC that has a similar output.

#### Driving the ADL5370 with an Analog Devices TxDAC®

An example of the interface using the AD9779 TxDAC is shown in Figure 31. The baseband inputs of the ADL5370 require a dc bias of 500 mV. The average output current on each of the outputs of the AD9779 is 10 mA. Therefore, a single 50 Ω resistor to ground from each of the DAC outputs results in an average current of 10 mA flowing through each of the resistors, thus producing the desired 500 mV dc bias for the inputs to the ADL5370.

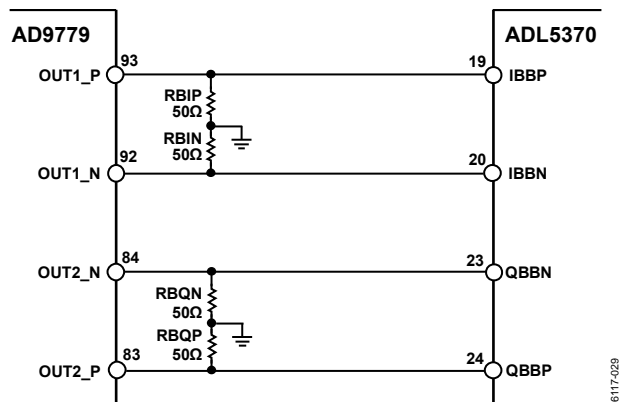

Figure 29. Interface Between the AD9779 and ADL5370 with 50 Ω Resistors to Ground to Establish the 500 mV DC Bias for the ADL5370 Baseband Inputs

The AD9779 output currents have a swing that ranges from 0 mA to 20 mA. With the 50 Ω resistors in place, the ac voltage swing going into the ADL5370 baseband inputs ranges from 0 V to 1 V. A full-scale sine wave out of the AD9779 can be described as a 1 V p-p single-ended (or 2 V p-p differential) sine wave with a 500 mV dc bias.

#### LIMITING THE AC SWING

There are situations in which it is desirable to reduce the ac voltage swing for a given DAC output current. This can be achieved through the addition of another resistor to the interface. This resistor is placed in shunt between each side of the differential pair, as shown in Figure 30. It has the effect of reducing the ac swing without changing the dc bias already established by the 50 Ω resistors.

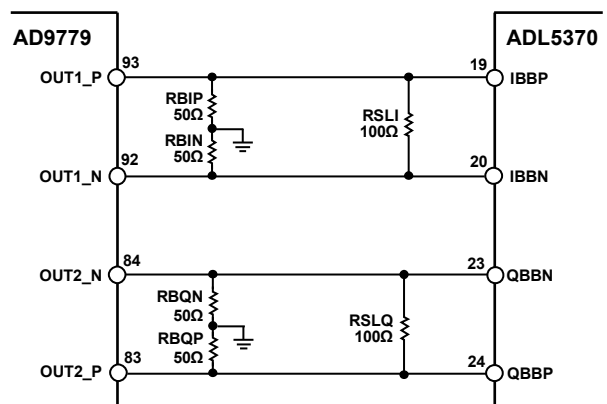

Figure 30. AC Voltage Swing Reduction Through the Introduction of a Shunt Resistor Between Differential Pair

The value of this ac voltage swing limiting resistor is chosen based on the desired ac voltage swing. Figure 31 shows the relationship between the swing-limiting resistor and the peak-to-peak ac swing that it produces when 50 Ω bias-setting resistors are used.

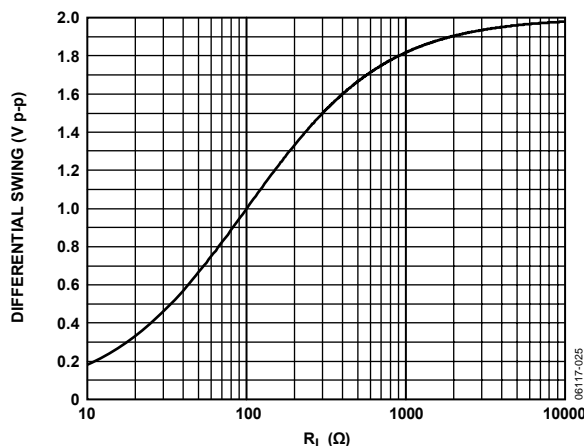

Figure 31. Relationship Between the AC Swing-Limiting Resistor and the Peak-to-Peak Voltage Swing with 50 Ω Bias-Setting Resistors

#### FILTERING

It is necessary to low-pass filter the DAC outputs to remove images when driving a modulator. The interface for setting up the biasing and ac swing that was discussed in the Limiting the AC Swing section lends itself well to the introduction of such a filter. The filter can be inserted between the dc bias setting resistors and the ac swing-limiting resistor. Doing so establishes the input and output impedances for the filter.

An example is shown in Figure 32 with a third-order elliptical filter with a 3 dB frequency of 3 MHz. Matching input and output impedances makes the filter design easier, so the shunt resistor chosen is 100 Ω, producing an ac swing of 1 V p-p differential.

# ADL5370

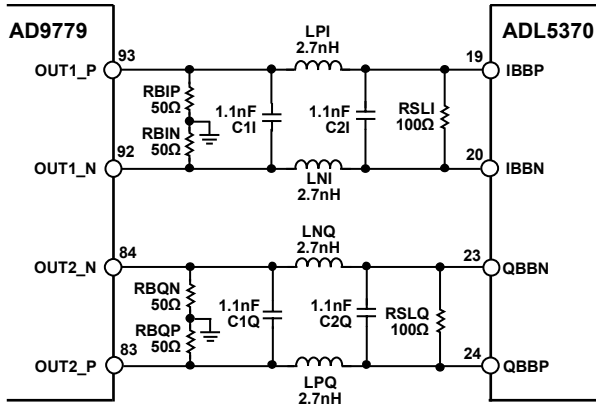

Figure 32. DAC Modulator Interface with 3 MHz Third-Order Low-Pass Filter

## USING THE AD9779 AUXILIARY DAC FOR CARRIER FEEDTHROUGH NULLING

The AD9779 features an auxiliary DAC that can be used to inject small currents into the differential outputs for each main DAC channel. This feature can be used to produce the small offset voltages necessary to null out the carrier feedthrough from the modulator. Figure 33 shows the interface required to utilize the auxiliary DACs. This adds four resistors to the interface.

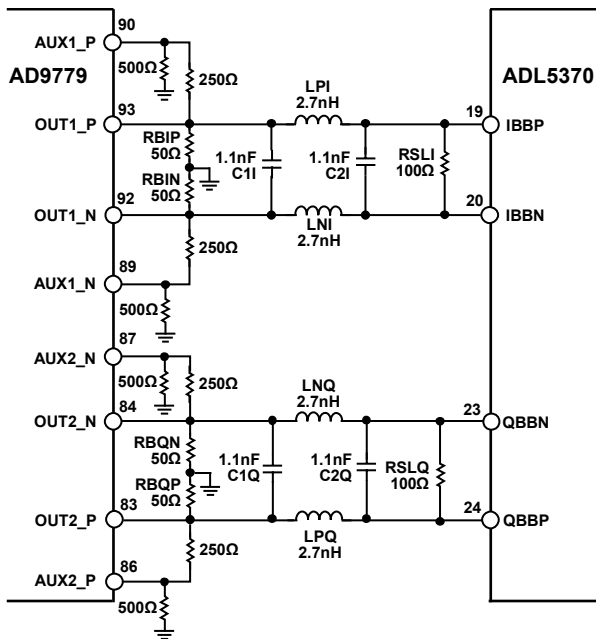

Figure 33. DAC Modulator Interface with Auxiliary DAC Resistors

## GSM OPERATION

Figure 34 shows the GSM EVM and spectral mask performance vs. output power for the ADL5370 at 450 MHz. For a given LO amplitude, the performance is independent of output power.

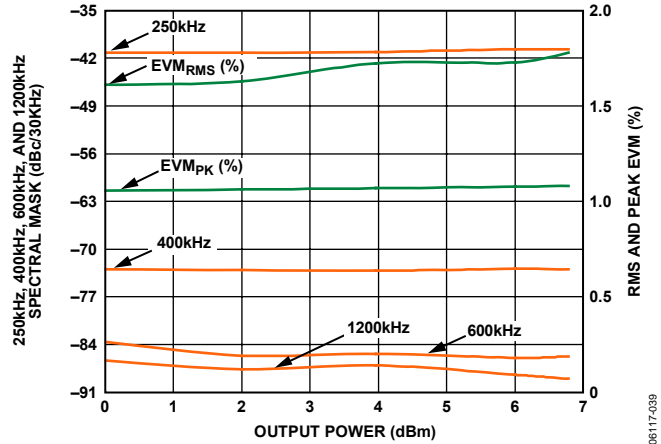

Figure 34. GSM EVM and Spectral Performance vs. Channel Power at 450 MHz vs. Output Power; LO Power = 0 dBm

Figure 35 shows the GSM EVM, spectral mask performance and 6 MHz offset noise vs. LO amplitude at 450 MHz with an output power of 6 dBm. Increasing the LO drive level improves the noise performance but degrades EVM performance.

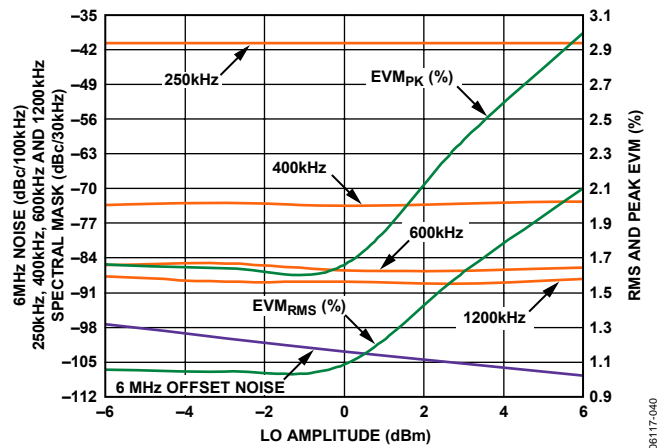

Figure 35. GSM EVM, Spectral Performance, and 6 MHz Noise Floor vs. LO Power at 450 MHz; Output Power = 6 dBm

Figure 35 illustrates that an LO amplitude of 0 dBm provides the ideal operating point for noise and EVM for a GSM signal at 450 MHz.

## LO GENERATION USING PLLS

Analog Devices has a line of PLLs that can be used for generating the LO signal. Table 4 lists the PLLs together with their maximum frequency and phase noise performance.

**Table 4. ADI PLL Selection Table**

Part	Frequency $F_{IN}$ (MHz)	Phase Noise @ 1 kHz Offset and 200 kHz PFD (dBc/Hz)
ADF4110	550	−91 @ 540 MHz
ADF4111	1200	−87 @ 900 MHz
ADF4112	3000	−90 @ 900 MHz
ADF4113	4000	−91 @ 900 MHz
ADF4116	550	−89 @ 540 MHz
ADF4117	1200	−87 @ 900 MHz
ADF4118	3000	−90 @ 900 MHz

The [ADF4360](#) comes as a family of chips, with nine operating frequency ranges. One is chosen, depending on the local oscillator frequency required. While the use of the integrated synthesizer may come at the expense of slightly degraded noise performance from the ADL5370, it can be a cheaper alternative to a separate PLL and VCO solution. Table 5 shows the options available.

**Table 5. ADF4360 Family Operating Frequencies**

Part	Output Frequency Range (MHz)
ADF4360-0	2400 to 2725
ADF4360-1	2050 to 2450
ADF4360-2	1850 to 2150
ADF4360-3	1600 to 1950
ADF4360-4	1450 to 1750
ADF4360-5	1200 to 1400
ADF4360-6	1050 to 1250
ADF4360-7	350 to 1800
ADF4360-8	65 to 400

## TRANSMIT DAC OPTIONS

The [AD9779](#) recommended in the previous sections of this data sheet is by no means the only DAC that can be used to drive the ADL5370. There are other appropriate DACs, depending on the level of performance required. Table 6 lists the dual Tx-DACs offered by Analog Devices.

**Table 6. Analog Devices Dual Tx—DAC Selection Table**

Part	Resolution (Bits)	Update Rate (MSPS Min)
AD9709	8	125
AD9761	10	40
AD9763	10	125
AD9765	12	125
AD9767	14	125
AD9773	12	160
AD9775	14	160
AD9777	16	160
AD9776	12	1000
AD9778	14	1000
AD9779	16	1000

All DACs listed have nominal bias levels of 0.5 V and use the same simple DAC-modulator interface that is shown in Figure 31.

## MODULATOR/DEMODULATOR OPTIONS

Table 7 lists other Analog Devices modulators and demodulators.

**Table 7. Modulator/Demodulator Options**

Part	Mod/Demod	Frequency Range (MHz)	Comments
AD8345	Mod	140 to 1000	External quadrature
AD8346	Mod	800 to 2500	
AD8349	Mod	700 to 2700	
ADL5390	Mod	20 to 2400	
ADL5385	Mod	50 to 2200	
ADL5371	Mod	700 to 1300	
ADL5372	Mod	1600 to 2400	
ADL5373	Mod	2300 to 3000	
ADL5374	Mod	3000 to 4000	
AD8347	Demod	800 to 2700	
AD8348	Demod	50 to 1000	
AD8340	Vector mod	700 to 1000	
AD8341	Vector mod	1500 to 2400	

# ADL5370

## EVALUATION BOARD

Populated RoHS-compliant evaluation boards are available for evaluation of the ADL5370. The ADL5370 package has an exposed paddle on the underside. This exposed paddle must be soldered to the board (see the Power Supply and Grounding discussion in the Basic Connections section). The evaluation board is designed without any components on the underside so heat can be applied to the underside for easy removal and replacement of the ADL5370.

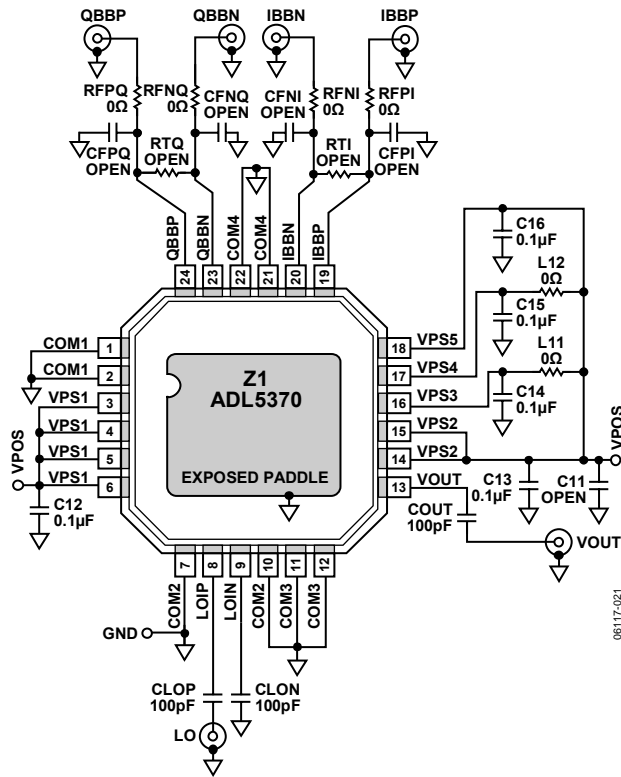

Figure 36. ADL5370 Evaluation Board Schematic

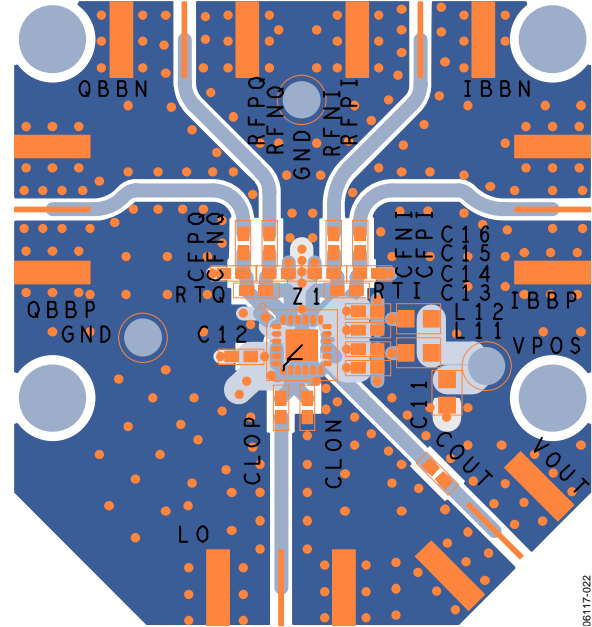

Figure 37. Evaluation Board Layout, Top Layer.

Table 8. Evaluation Board Configuration Options

Component	Description	Default Condition
VPOS, GND	Power Supply and Ground Clip Leads.	Not applicable
RFPI, RFNI, RFPQ, RFNQ, CFPI, CFNI, CFPQ, CFNQ, RTQ, RTI	Baseband Input Filters. These components can be used to implement a low-pass filter for the baseband signals. See the Filtering discussion in the Applications Information section.	RFNQ, RFPQ, RFNI, RFPI = 0 Ω (0402) CFNQ, CFPQ, CFNI, CFPI = Open (0402) RTQ, RTI = Open (0402)

## CHARACTERIZATION SETUP

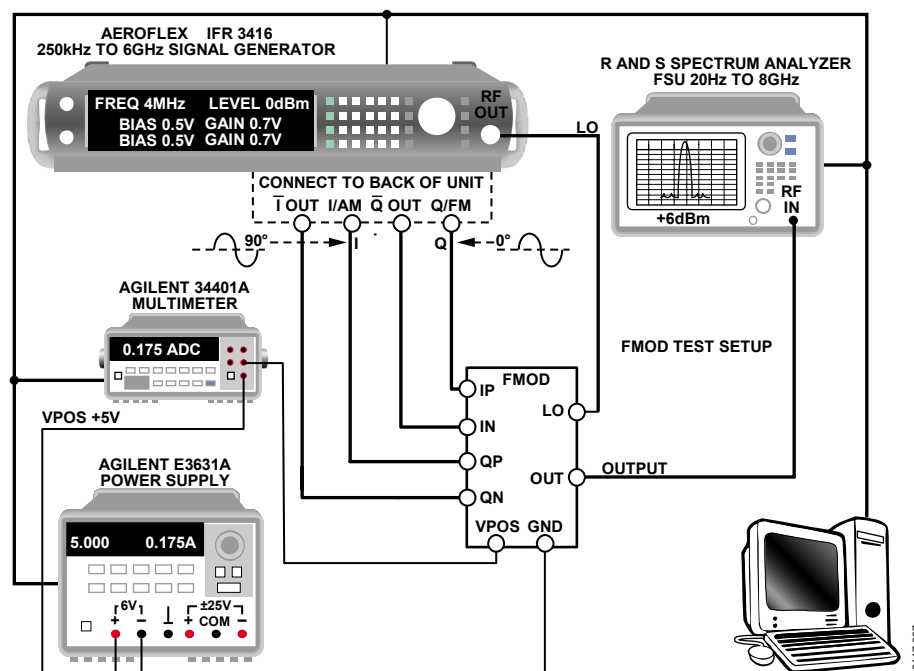

Figure 38. Characterization Bench Setup

The primary setup used to characterize the ADL5370 is shown in Figure 38. This setup was used to evaluate the product as a single-sideband modulator. The Aeroflex signal generator supplied the local oscillator (LO) and differential I and Q baseband signals to the device under test, DUT. The typical LO drive was 0 dBm. The I channel is driven by a sine wave, and the Q channel is driven by a cosine wave. The lower sideband is the single sideband (SSB) output.

The majority of characterization for the ADL5370 was performed using a 1 MHz sine wave signal with a 500 mV common-mode voltage applied to the baseband signals of the DUT. The baseband signal path was calibrated to ensure that the  $V_{Ios}$ <sup>1</sup> and  $V_{Qos}$  offsets on the baseband inputs were minimized, as close as possible, to 0 V before connecting to the DUT.

<sup>1</sup> See the Carrier Feedthrough Nulling section for the definitions of  $V_{Ios}$  and  $V_{Qos}$ .

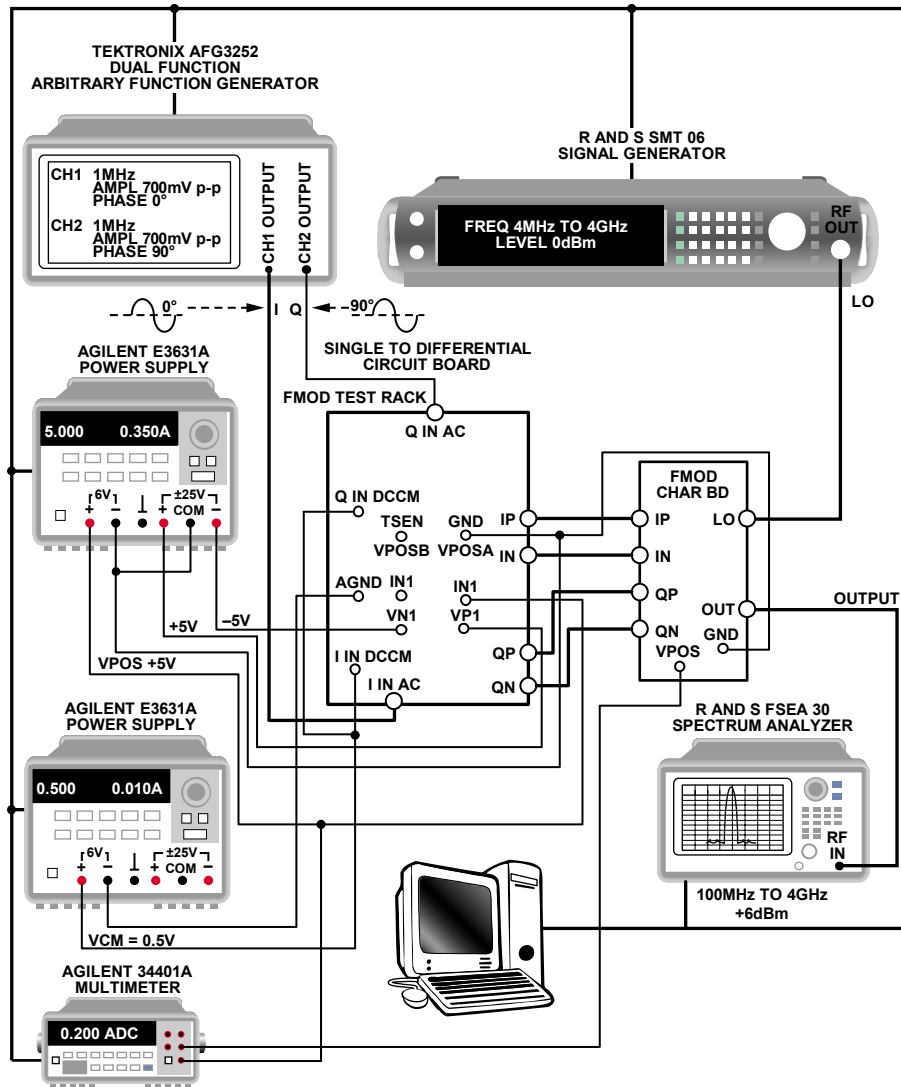

Figure 39. Setup for Baseband Frequency Sweep and Undesired Sideband Nulling

The setup used to evaluate baseband frequency sweep and undesired sideband nulling of the ADL5370 is shown in Figure 39. The interface board has circuitry that converts the single-ended I and Q inputs from the arbitrary function generator to differential I and Q baseband signals with a dc bias of 500 mV.

Undesired sideband nulling was achieved through an iterative process of adjusting amplitude and phase on the Q channel. See Sideband Suppression Optimization in the Optimization section for a more detailed discussion on sideband nulling.



**ADL5370**

**NOTES**

## Looking for pricing, stock, or lifecycle information?

Click below to explore more details on WIN SOURCE:

 [View ADL5370ACPZ-R7 on WIN SOURCE](#)

 [Analog Devices Inc. Information](#)

## Optimize Your Supply Chain with WIN SOURCE Solutions

-  Global Sourcing Solution
-  Obsolete Management
-  Cost Control Management
-  Shortage Management
-  Alternative Solution
-  Excess Inventory Management