



THE DATASHEET OF ADG779BKSZ-REEL



FEATURES

- 1.8 V to 5.5 V single supply**
- 2.5 Ω on resistance**
- 0.75 Ω on-resistance flatness**
- 3 dB bandwidth >200 MHz**
- Rail-to-rail operation**
- 6-lead SC70 package**
- Fast switching times**
 - t_{ON} 20 ns**
 - t_{OFF} 6 ns**
- Typical power consumption (<0.01 μ W)**
- TTL/CMOS compatible**

APPLICATIONS

- Battery-powered systems**
- Communication systems**
- Sample hold systems**
- Audio signal routing**
- Video switching**
- Mechanical reed relay replacements**

GENERAL DESCRIPTION

The ADG779 is a monolithic CMOS SPDT (single-pole, double-throw) switch. This switch is designed on a submicron process that provides low power dissipation yet gives high switching speed, low on resistance, and low leakage currents.

The ADG779 operates from a single supply range of 1.8 V to 5.5 V, making it ideal for use in battery-powered instruments and with the new generation of DACs and ADCs from Analog Devices, Inc.

Each switch of the ADG779 conducts equally well in both directions when on. The ADG779 exhibits break-before-make switching action.

Because of the advanced submicron process, -3 dB bandwidth of greater than 200 MHz can be achieved.

The ADG779 is available in a 6-lead SC70 package.

FUNCTIONAL BLOCK DIAGRAM

Figure 1.

PRODUCT HIGHLIGHTS

1. Tiny 6-Lead SC70 Package.
2. 1.8 V to 5.5 V Single-Supply Operation. The ADG779 offers high performance, including low on resistance and fast switching times, and is fully specified and guaranteed with 3 V and 5 V supply rails.
3. Very Low R_{ON} (5 Ω max at 5 V, 10 Ω max at 3 V). At 1.8 V operation, R_{ON} is typically 40 Ω over the temperature range.
4. On-Resistance Flatness (R_{FLAT(ON)}) (0.75 Ω typ).
5. -3 dB Bandwidth > 200 MHz.
6. Low Power Dissipation. CMOS construction ensures low power dissipation.
7. 14 ns Switching Times.

Rev. A

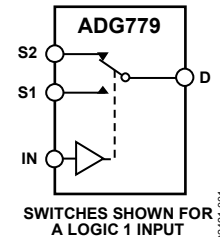
Information furnished by Analog Devices is believed to be accurate and reliable. However, no responsibility is assumed by Analog Devices for its use, nor for any infringements of patents or other rights of third parties that may result from its use. Specifications subject to change without notice. No license is granted by implication or otherwise under any patent or patent rights of Analog Devices. Trademarks and registered trademarks are the property of their respective owners.

TABLE OF CONTENTS

Features	1	Pin Configuration and Function Descriptions.....	6
Applications.....	1	Terminology	7
Functional Block Diagram	1	Typical Performance Characteristics	8
General Description	1	Test Circuits.....	10
Product Highlights	1	Outline Dimensions	12
Revision History	2	Ordering Guide	12
Specifications.....	3		
Absolute Maximum Ratings.....	5		
ESD Caution.....	5		

REVISION HISTORY

10/05—Rev. 0 to Rev. A

Updated Format	Universal
Changes to Table 1.....	3
Changes to Table 2.....	4
Changes to Table 3.....	5
Changes to Terminology Section.....	7
Changes to Ordering Guide	12

7/01—Revision 0: Initial Version

SPECIFICATIONS

$V_{DD} = 5\text{ V} \pm 10\%$, $GND = 0\text{ V}$ ¹

Table 1.

Parameter	B Version		Unit	Test Conditions/Comments
	25°C	–40°C to +85°C		
ANALOG SWITCH				
Analog Signal Range		0 V to V_{DD}	V	
On Resistance (R_{ON})	2.5		Ω typ	$V_S = 0\text{ V to }V_{DD}$, $I_S = -10\text{ mA}$, see Figure 12
	5	6	Ω max	
On-Resistance Match Between Channels (ΔR_{ON})	0.1		Ω typ	$V_S = 0\text{ V to }V_{DD}$, $I_S = -10\text{ mA}$
		0.8	Ω max	
On-Resistance Flatness ($R_{FLAT(ON)}$)	0.75		Ω typ	$V_S = 0\text{ V to }V_{DD}$, $I_S = -10\text{ mA}$
		1.2	Ω max	
LEAKAGE CURRENTS²				
Source Off Leakage I_S (Off)	± 0.01	± 0.05	nA typ	$V_{DD} = 5.5\text{ V}$ $V_S = 4.5\text{ V}/1\text{ V}$, $V_D = 1\text{ V}/4.5\text{ V}$, see Figure 13
Channel On Leakage I_D , I_S (On)	± 0.01	± 0.05	nA typ	$V_S = V_D = 1\text{ V}$, or $V_S = V_D = 4.5\text{ V}$, see Figure 14
DIGITAL INPUTS				
Input High Voltage, V_{INH}		2.4	V min	
Input Low Voltage, V_{INL}		0.8	V max	
Input Current				
I_{INL} or I_{INH}	0.005		μA typ	$V_{IN} = V_{INL}$ or V_{INH}
		± 0.1	μA max	
DYNAMIC CHARACTERISTICS²				
t_{ON}	14		ns typ	$R_L = 300\ \Omega$, $C_L = 35\text{ pF}$ $V_S = 3\text{ V}$, see Figure 15
		20	ns max	
t_{OFF}	3		ns typ	$R_L = 300\ \Omega$, $C_L = 35\text{ pF}$ $V_S = 3\text{ V}$, see Figure 15
		6	ns max	
Break-Before-Make Time Delay, t_D	8		ns typ	$R_L = 300\ \Omega$, $C_L = 35\text{ pF}$ $V_{S1} = V_{S2} = 3\text{ V}$, see Figure 16
		1	ns min	
Off Isolation	–67		dB typ	$R_L = 50\ \Omega$, $C_L = 5\text{ pF}$, $f = 10\text{ MHz}$ $R_L = 50\ \Omega$, $C_L = 5\text{ pF}$, $f = 1\text{ MHz}$, see Figure 17
	–87		dB typ	
Channel-to-Channel Crosstalk	–62		dB typ	$R_L = 50\ \Omega$, $C_L = 5\text{ pF}$, $f = 10\text{ MHz}$ $R_L = 50\ \Omega$, $C_L = 5\text{ pF}$, $f = 1\text{ MHz}$, see Figure 18
	–82		dB typ	
Bandwidth –3 dB	200		MHz typ	$R_L = 50\ \Omega$, $C_L = 5\text{ pF}$, see Figure 19
C_S (Off)	7		pF typ	
C_D , C_S (On)	27		pF typ	$f = 1\text{ MHz}$
POWER REQUIREMENTS				
I_{DD}	0.001		μA typ	$V_{DD} = 5.5\text{ V}$ Digital Inputs = 0 V or 5 V
		1.0	μA max	

¹ Temperature range is B Version, –40°C to +85°C.

² Guaranteed by design, not subject to production test.

ADG779

$V_{DD} = 3\text{ V} \pm 10\%$, $GND = 0\text{ V}$ ¹

Table 2.

Parameter	B Version		Unit	Test Conditions/Comments
	25°C	−40°C to +85°C		
ANALOG SWITCH				
Analog Signal Range		0 V to V_{DD}	V	
On Resistance (R_{ON})	6	7	Ω typ	$V_S = 0\text{ V to }V_{DD}$, $I_S = -10\text{ mA}$, see Figure 12
		10	Ω max	
On-Resistance Match Between Channels (ΔR_{ON})	0.1		Ω typ	$V_S = 0\text{ V to }V_{DD}$, $I_S = -10\text{ mA}$
		0.8	Ω max	
On-Resistance Flatness ($R_{FLAT(ON)}$)	2.5		Ω typ	$V_S = 0\text{ V to }V_{DD}$, $I_S = -10\text{ mA}$
LEAKAGE CURRENTS ²				
Source Off Leakage I_S (Off)	± 0.01	± 0.05	nA typ	$V_{DD} = 3.3\text{ V}$ $V_S = 3\text{ V}/1\text{ V}$, $V_D = 1\text{ V}/3\text{ V}$, see Figure 13
Channel On Leakage I_D , I_S (On)	± 0.01	± 0.05	nA typ	$V_S = V_D = 1\text{ V}$, or $V_S = V_D = 3\text{ V}$, see Figure 14
DIGITAL INPUTS				
Input High Voltage, V_{INH}		2.0	V min	
Input Low Voltage, V_{INL}		0.8	V max	
Input Current				
I_{INL} or I_{INH}	0.005		μA typ	$V_{IN} = V_{INL}$ or V_{INH}
		± 0.1	μA max	
DYNAMIC CHARACTERISTICS ²				
t_{ON}	16		ns typ	$R_L = 300\ \Omega$, $C_L = 35\text{ pF}$
		24	ns max	$V_S = 2\text{ V}$, see Figure 15
t_{OFF}	4		ns typ	$R_L = 300\ \Omega$, $C_L = 35\text{ pF}$
		7	ns max	$V_S = 2\text{ V}$, see Figure 15
Break-Before-Make Time Delay, t_D	8		ns typ	$R_L = 300\ \Omega$, $C_L = 35\text{ pF}$
		1	ns min	$V_{S1} = V_{S2} = 2\text{ V}$, see Figure 16
Off Isolation	−67		dB typ	$R_L = 50\ \Omega$, $C_L = 5\text{ pF}$, $f = 10\text{ MHz}$
	−87		dB typ	$R_L = 50\ \Omega$, $C_L = 5\text{ pF}$, $f = 1\text{ MHz}$, see Figure 17
Channel-to-Channel Crosstalk	−62		dB typ	$R_L = 50\ \Omega$, $C_L = 5\text{ pF}$, $f = 10\text{ MHz}$
	−82		dB typ	$R_L = 50\ \Omega$, $C_L = 5\text{ pF}$, $f = 1\text{ MHz}$, see Figure 18
Bandwidth −3 dB	200		MHz typ	$R_L = 50\ \Omega$, $C_L = 5\text{ pF}$, see Figure 19
C_S (Off)	7		pF typ	$f = 1\text{ MHz}$
C_D , C_S (On)	27		pF typ	$f = 1\text{ MHz}$
POWER REQUIREMENTS				
I_{DD}	0.001		μA typ	$V_{DD} = 3.3\text{ V}$ Digital Inputs = 0 V or 3 V
		1.0	μA max	

¹ Temperature range is B Version, −40°C to +85°C.

² Guaranteed by design, not subject to production test.

ABSOLUTE MAXIMUM RATINGS

$T_A = 25^\circ\text{C}$, unless otherwise noted.

Table 3.

Parameter	Rating
V_{DD} to GND	-0.3 V to +7 V
Analog, Digital Inputs ¹	-0.3 V to $V_{DD} + 0.3$ V or 30 mA, whichever occurs first
Peak Current, S or D	100 mA (pulsed at 1 ms, 10% duty cycle max)
Continuous Current, S or D	30 mA
Operating Temperature Range	
Industrial (B Version)	-40°C to +85°C
Storage Temperature Range	-65°C to +150°C
Junction Temperature	150°C
SC70 Package, Power Dissipation	315 mW
θ_{JA} Thermal Impedance	332°C/W
θ_{JC} Thermal Impedance	120°C/W
Lead Temperature, Soldering	
Vapor Phase (60 sec)	215°C
Infrared (15 sec)	220°C
Reflow Soldering (Pb-free)	
Peak Temperature	260 (+0/-5)°C
Time at Peak Temperature	10 sec to 40 sec

¹ Overvoltages at IN, S, or D are clamped by internal diodes. Current should be limited to the maximum ratings given.

Stresses above those listed under Absolute Maximum Ratings may cause permanent damage to the device. This is a stress rating only; functional operation of the device at these or any other conditions above those indicated in the operational section of this specification is not implied. Exposure to absolute maximum rating conditions for extended periods may affect device reliability.

Table 4. Truth Table

ADG779 IN	Switch S1	Switch S2
0	On	Off
1	Off	On

ESD CAUTION

ESD (electrostatic discharge) sensitive device. Electrostatic charges as high as 4000 V readily accumulate on the human body and test equipment and can discharge without detection. Although this product features proprietary ESD protection circuitry, permanent damage may occur on devices subjected to high energy electrostatic discharges. Therefore, proper ESD precautions are recommended to avoid performance degradation or loss of functionality.



ADG779

PIN CONFIGURATION AND FUNCTION DESCRIPTIONS

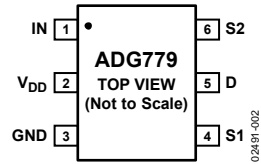

Figure 2. Pin Configuration

Table 5. Pin Function Descriptions

Pin No.	Mnemonic	Description
1	IN	Logic Control Input.
2	V _{DD}	Most Positive Power Supply Potential.
3	GND	Ground (0 V) Reference.
4	S1	Source Terminal. Can be an input or an output.
5	D	Drain Terminal. Can be an input or an output.
6	S2	Source Terminal. Can be an input or an output.

TERMINOLOGY

V_{DD}

Most positive power supply potential.

I_{DD}

Positive supply current.

GND

Ground (0 V) reference.

S

Source terminal. Can be an input or an output.

D

Drain terminal. Can be an input or an output.

IN

Logic control input.

$V_D (V_S)$

Analog voltage on drain (D) and source (S) terminals.

R_{ON}

Ohmic resistance between the D and S.

$R_{FLAT (ON)}$

Flatness is defined as the difference between the maximum and minimum value of on resistance as measured.

ΔR_{ON}

On-resistance mismatch between any two channels.

$I_S (Off)$

Source leakage current with the switch off.

$I_D (Off)$

Drain leakage current with the switch off.

$I_D, I_S (On)$

Channel leakage current with the switch on.

V_{INL}

Maximum input voltage for Logic 0.

V_{INH}

Minimum input voltage for Logic 1.

$I_{INL} (I_{INH})$

Input current of the digital input.

$C_S (Off)$

Off switch source capacitance. Measured with reference to ground.

$C_D (Off)$

Off switch drain capacitance. Measured with reference to ground.

$C_D, C_S (On)$

On switch capacitance. Measured with reference to ground.

C_{IN}

Digital input capacitance.

t_{ON}

Delay time between the 50% and 90% points of the digital input and switch on condition.

t_{OFF}

Delay time between the 50% and 90% points of the digital input and switch off condition.

t_{BBM}

On or off time measured between the 80% points of both switches when switching from one to another.

Charge Injection

A measure of the glitch impulse transferred from the digital input to the analog output during on/off switching.

Off Isolation

A measure of unwanted signal coupling through an off switch.

Crosstalk

A measure of unwanted signal that is coupled through from one channel to another because of parasitic capacitance.

-3 dB Bandwidth

The frequency at which the output is attenuated by 3 dB.

On Response

The frequency response of the on switch.

Insertion Loss

The loss due to the on resistance of the switch.

THD + N

The ratio of harmonic amplitudes plus noise of a signal to the fundamental.

TYPICAL PERFORMANCE CHARACTERISTICS

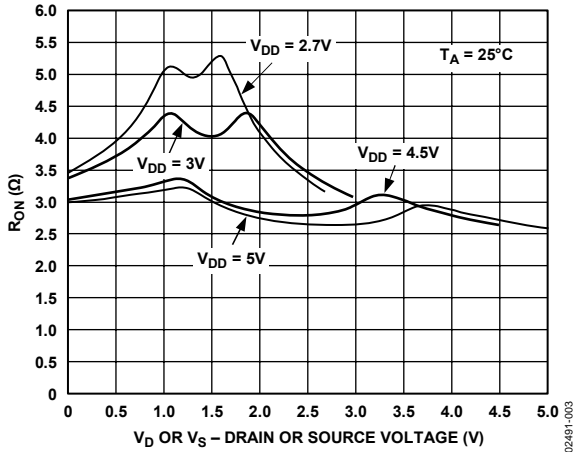

Figure 3. On Resistance as a Function of V_D (V_S) Single Supplies

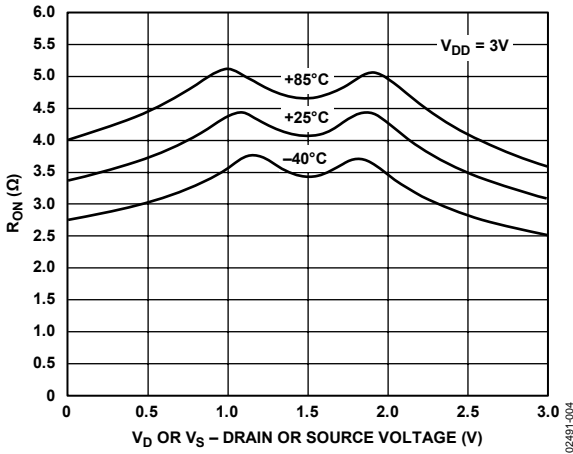

Figure 4. On Resistance as a Function of V_D (V_S) for Different Temperatures $V_{DD} = 3V$

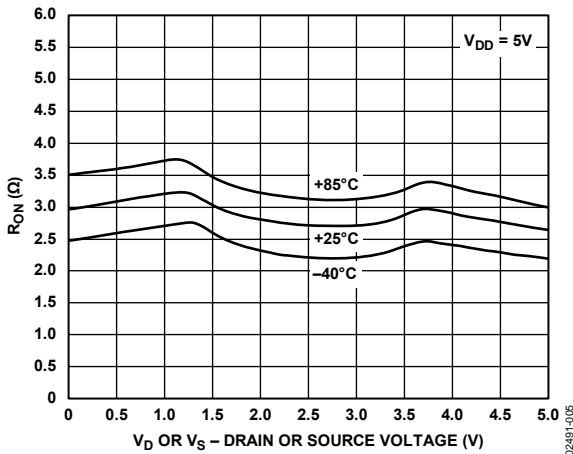

Figure 5. On Resistance as a Function of V_D (V_S) for Different Temperatures $V_{DD} = 5V$

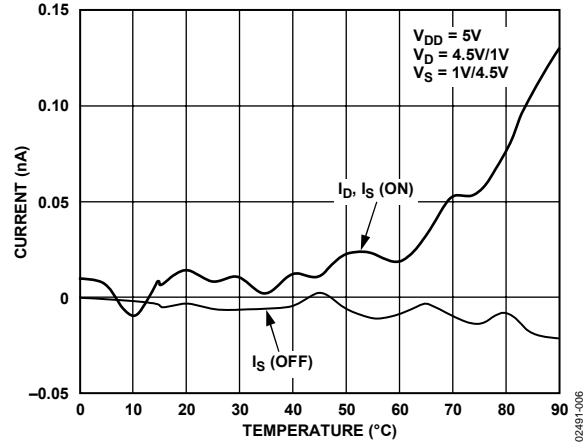

Figure 6. Leakage Currents as a Function of Temperature

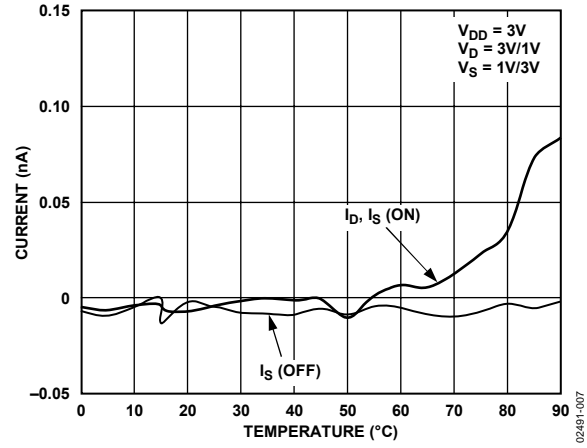

Figure 7. Leakage Currents as a Function of Temperature

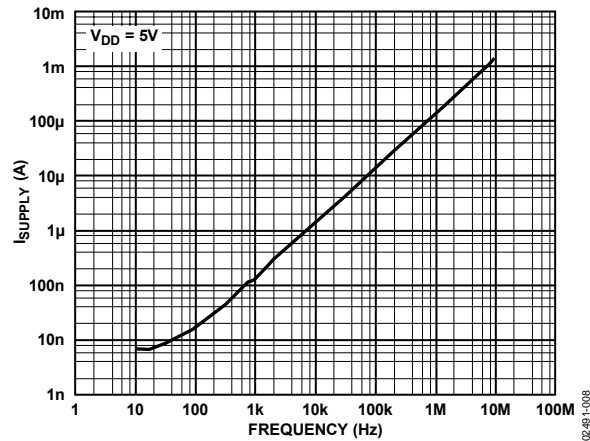

Figure 8. Supply Current vs. Input Switching Frequency

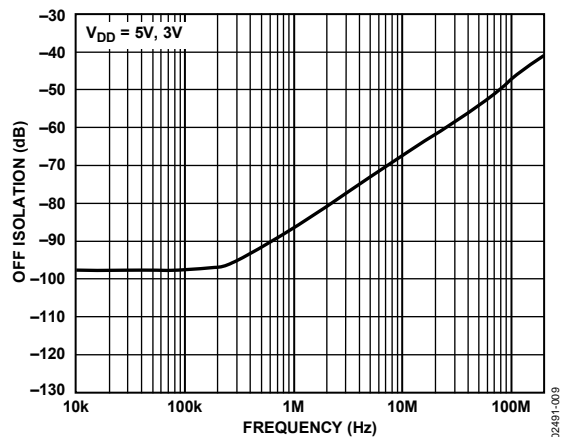

Figure 9. Off Isolation vs. Frequency

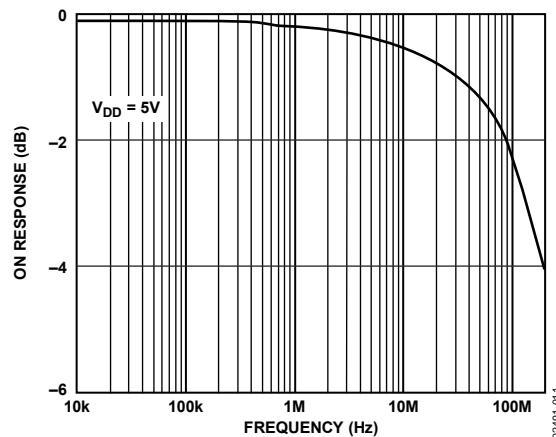

Figure 11. On Response vs. Frequency

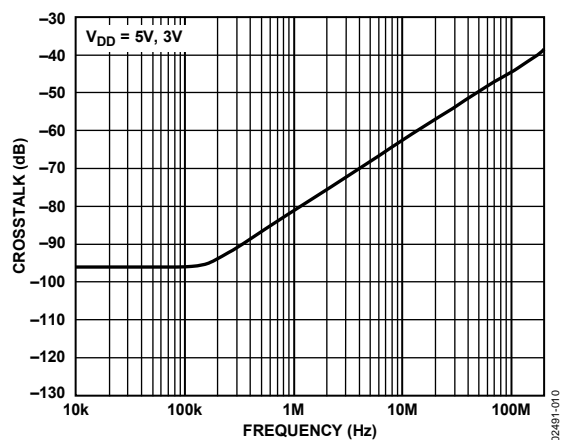

Figure 10. Crosstalk vs. Frequency

TEST CIRCUITS

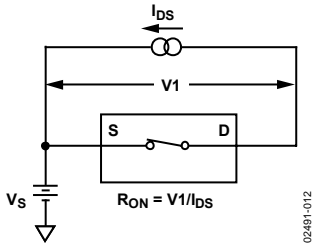

Figure 12. On Resistance

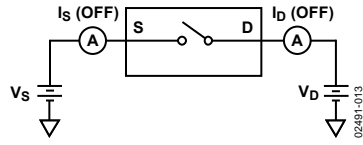

Figure 13. Off Leakage

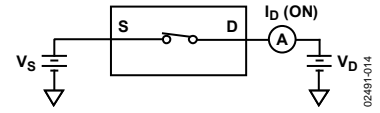

Figure 14. On Leakage

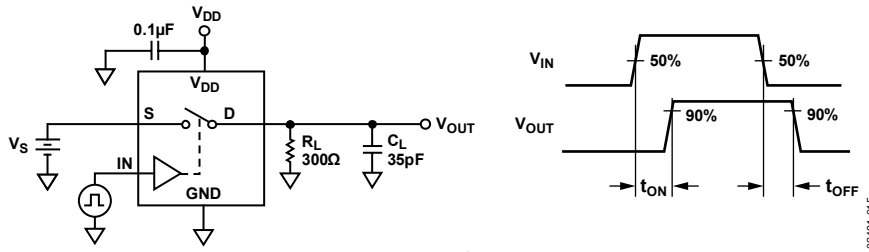

Figure 15. Switching Times

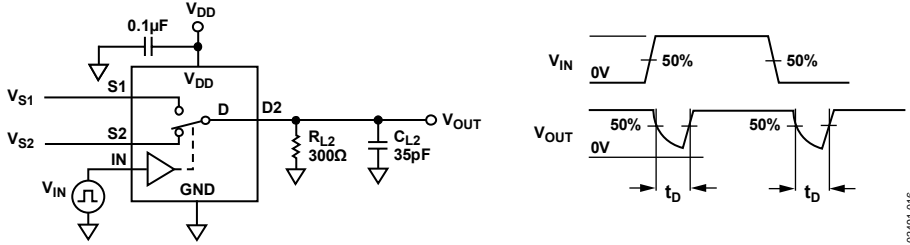
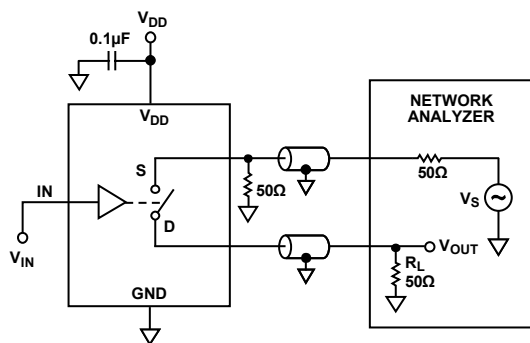

Figure 16. Break-Before-Make Time Delay, t_b



$$\text{OFF ISOLATION} = 20 \log \frac{V_{\text{OUT}}}{V_{\text{S}}}$$

02491-017

Figure 17. Off Isolation

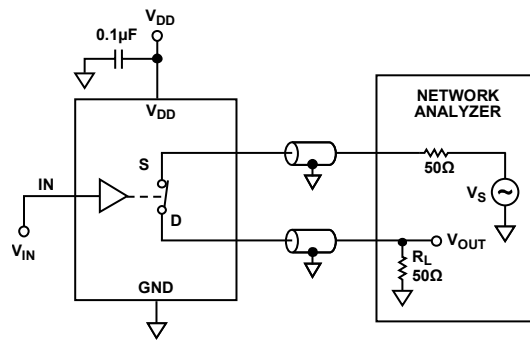

$$\text{INSERTION LOSS} = 20 \log \frac{V_{\text{OUT WITH SWITCH}}}{V_{\text{OUT WITHOUT SWITCH}}}$$

02491-019

Figure 19. Bandwidth

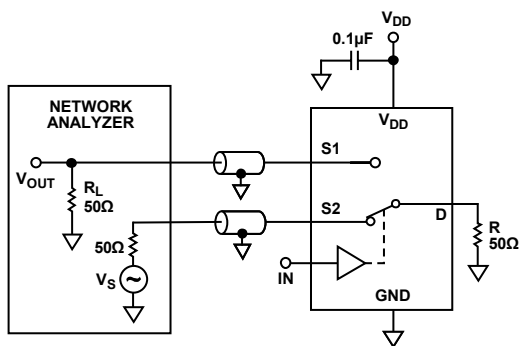

$$\text{CHANNEL-TO-CHANNEL CROSSTALK} = 20 \log \frac{V_{\text{OUT}}}{V_{\text{S}}}$$

02491-018

Figure 18. Channel-to-Channel Crosstalk

OUTLINE DIMENSIONS

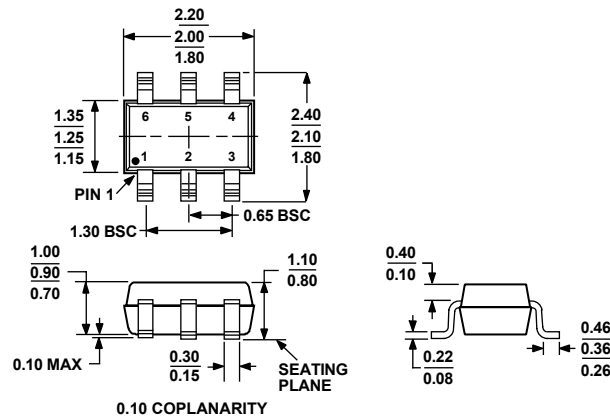

COMPLIANT TO JEDEC STANDARDS MO-203-AB
 Figure 20. 6-Lead Thin Shrink Small Outline Transistor Package [SC70]
 (KS-6)
 Dimensions shown in millimeters

ORDERING GUIDE

Model	Temperature Range	Package Description	Package Option	Branding ¹
ADG779BKS-R2	-40°C to +85°C	6-Lead Thin Shrink Small Outline Transistor Package (SC70)	KS-6	SKB
ADG779BKS-REEL	-40°C to +85°C	6-Lead Thin Shrink Small Outline Transistor Package (SC70)	KS-6	SKB
ADG779BKS-REEL7	-40°C to +85°C	6-Lead Thin Shrink Small Outline Transistor Package (SC70)	KS-6	SKB
ADG779BKSZ-R2 ²	-40°C to +85°C	6-Lead Thin Shrink Small Outline Transistor Package (SC70)	KS-6	SOM
ADG779BKSZ-REEL ²	-40°C to +85°C	6-Lead Thin Shrink Small Outline Transistor Package (SC70)	KS-6	SOM
ADG779BKSZ-REEL7 ²	-40°C to +85°C	6-Lead Thin Shrink Small Outline Transistor Package (SC70)	KS-6	SOM

¹ Brand on these packages is limited to three characters due to space constraints.

² Z = Pb-free part.

Looking for pricing, stock, or lifecycle information?

Click below to explore more details on WIN SOURCE:

- ⊖ [View ADG779BKSZ-REEL on WIN SOURCE](#)
- ⊖ [Analog Devices Inc. Information](#)

Optimize Your Supply Chain with WIN SOURCE Solutions

- ✓ Global Sourcing Solution
- ✓ Obsolete Management
- ✓ Cost Control Management
- ✓ Shortage Management
- ✓ Alternative Solution
- ✓ Excess Inventory Management